

ROTTLER

**EM79 SERIES CNC
MACHINING CENTER
OPTIONAL EQUIPMENT
PARTS MANUAL**

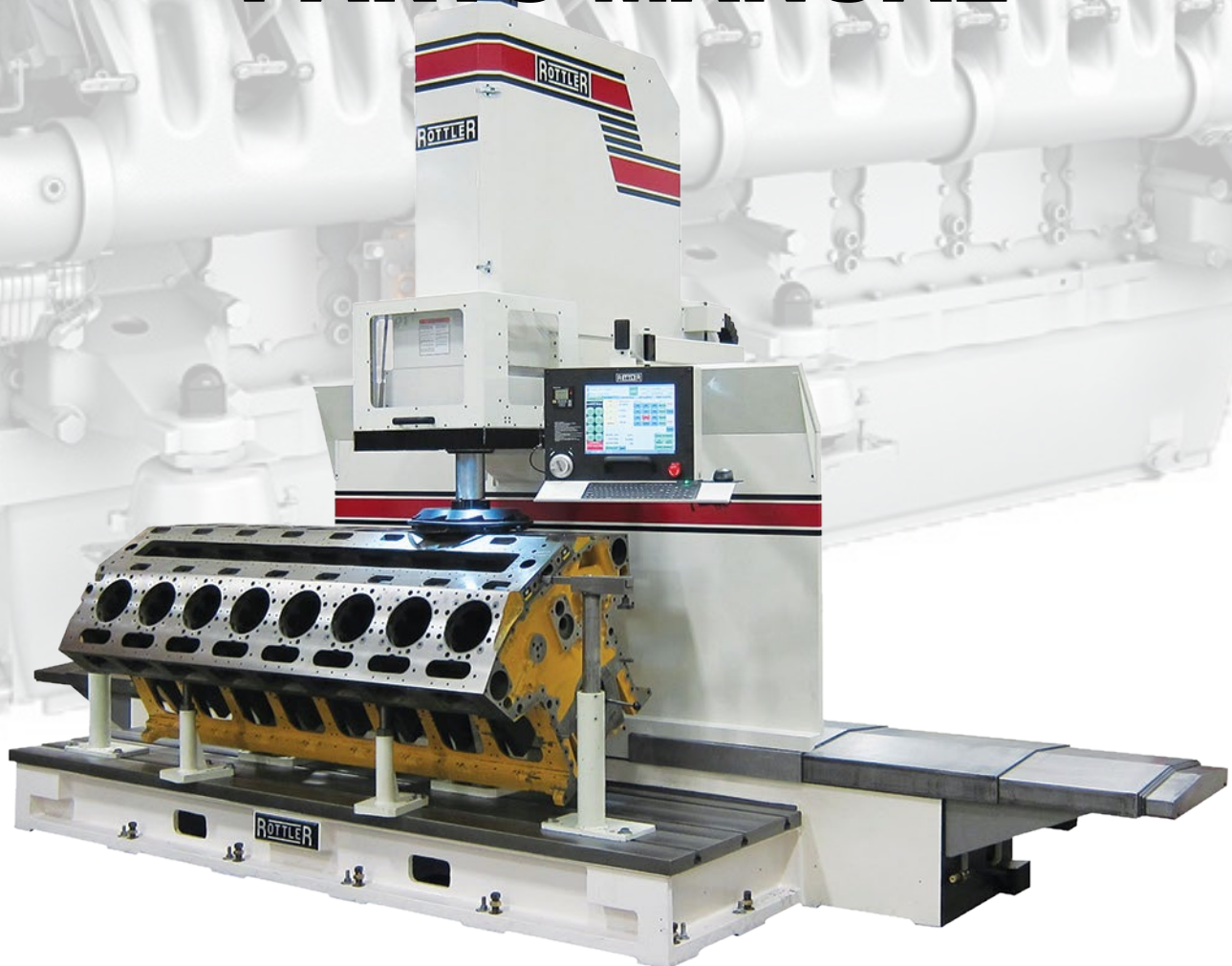





ORDERING PROCEDURE

Contact your regional Rottler sales rep for assistance in ordering optional equipment, replacement parts, or tooling.

If you are unable to contact your regional Rottler sales rep, call the factory at 253-872-7050 and ask to speak to the parts sales specialist.

Have the following information handy to expedite the ordering process:

1. Your name, business name, and contact number
2. Customer number
3. If you do not have a customer number, your billing address
4. Shipping address if different from billing address
5. Machine model and serial number
6. Part number and description of what you want to order
7. Preferred method of shipment

You may also contact us via e-mail with the above information. For customers within the U.S. send emails to parts@rottlermfg.com, for customers outside of the U.S. use intlparts@rottlermfg.com

In some cases you may be requested to send a photo of the part you are ordering if it is a replacement part, or doesn't appear in the database.

If you are unsure which part you need to order, contact our service department and ask to speak to one of our service consultants. They will assist you in determining which part you require.

THERE IS A MINIMUM ORDER OF \$25.00

EM79 SERIES OPTIONAL EQUIPMENT PARTS MANUAL

Cutting Tools	1
Boring Tools	1
650-2-1D Blind Hole Cutterhead Kit, 2.0-4.0" (51-102mm) x 7" (176mm).....	1
650-2-3T Blind Hole Cutterhead Kit, 2.0-4.0" (51-102mm) x 4.0" (102mm).....	3
11100 Blind Hole Cutterhead Kit, 3.8-5.0" (96.5-127mm)	5
650-2-15F Blind Hole Cutterhead Kit, 2.9-8.0" (73.5-203mm) x 4.0" (102mm).....	7
650-2-14B Blind Hole Cutterhead Kit, 2.9-8.0" (73.5-203mm) x 7" (176mm).....	9
11101 HD Cutterhead Kit, 4.5-7.0" (115-178mm).....	11
Surfacing Tools	13
650-2-8E Surfacing Flycutter Kit, 10" (254mm) Dia.....	13
650-2-8F Surfacing Flycutter Kit, 14" (356mm) Dia.....	14
650-2-44N Shell Mill Kit, 2.5" (63.5mm) Dia	15
650-2-44P Shell Mill Kit, 4" (102mm) Dia	16
Right Angle Drives	17
11103 Right Angle Drive.....	17
11103E Right Angle Drive, 2" Extended.....	21
11104 Special Belt Drive Right Angle Drive	25
11105 Narrow Right Angle Drive	29
Right Angle Drive Accessories.....	32
650-2-39B Line Boring Cutterhead Kit, 1.94-4.11" (49.28-104.39mm) Dia	32
650-2-39C Line Boring Cutterhead Kit, 2.82-5.52" (71.63-140.21mm) Dia.....	34
6855Q Thrust Facing Tool Package	36
Main Bore Chamfering Tools	36
Insert Holders	37
Miscellaneous Insert Holders and Tooling.....	37
6598 Insert Cartridge	38
6206L Insert Cartridge	39
6598R Insert Cartridge.....	39
6598M Insert Cartridge	40
6260W Insert Cartridge.....	40
6593 Series Insert Holder	41



6520 Series Insert Holder	41
6801 Series Insert Holder	42
6801M Tool Holder Package	43
6801P Tool Holder Package	44
Micrometers	45
900-2-19 Micrometer	45
900-2-20 Micrometer	45
General Purpose Tooling.....	46
6648W Caterpillar 3400 Tappet Bore Repair Kit	46
650-2-53 Splayed 4-Bolt main Cap Tooling Package.....	47
650-2-44M Drill Chuck Kit	48
10124 CAT 40 Collet Kit	48
11116 Crossfeed Head Assembly	49
650-2-3S Cutterhead Kit	50
650-2-11K Tap Driver.....	50
650-2-44A Endmill Adapter, 1" (25.4mm) Tooling	51
650-2-45H Endmill, 1" (25.4mm) x 8.5" (216mm) OL, Roughing.....	51
650-2-60B Lifter Bore Tooling Kit.....	52
Fixturing.....	53
Parallels.....	53
11115 Parallels, 2" x 3" (51mm x 76mm).....	53
11113L Parallels, 4" (102mm).....	54
11112 Parallels, 8" (203mm).....	56
11114 Parallels, 16" (406mm).....	58
Block Locating Fixtures.....	60
11121 Small to Mid-Range Fixture Kit	60
650-3-56 Line Bore Pivot Table Fixture Kit.....	62
11113 Adjustable Line Boring Parallel Kit.....	64
6843 90° V-Block Support Kit	66
6789L 113° V-Block Support Kit	67
6789E 115° V-Block Support Kit.....	68
6789N 116° V-Block Support Kit.....	69
6866 Wedge Kit, Cummins 5.9L Camshaft Bore.....	70
Miscellaneous Fixtures/Accessories.....	71
650-3-37 ½" (12.7mm) Clamp Kit	71
7209M Dual Axis Leveling Table	72
7209N 2-Piece Vice	78



11111 Tower Type Hold Down Clamp Kit.....	79
7152A Dual Axis Level.....	80
9111A T-Slot Plate for F60 Fixtures.....	81
650-2-60N Setting Fixture, Lifter Tooling.....	81
Auxiliary Equipment.....	82
650-3-59Y Renishaw Wireless Probe Kit.....	82
502-12-7B Digital Runout Probe and Readout Kit.....	83
502-12-4 General Purpose Magnetic Indicator Holder.....	83
502-12-4A Magnetic Indicator Holder.....	84
502-9-9S Indicator Mount.....	84
502-9-9A Mechanical Runout Indicator, Inch.....	84
502-9-9J Mechanical Runout Indicator, Metric.....	84
650-3-44S Precision Connecting Rod Fixture System.....	85
650-3-64 HD Precision Connecting Rod fixture System.....	91
690-3-70 Automatic 4 th Axis Fixture.....	97
650-3-84 Block Fixture Plates, Overhead Cam.....	101
11038 Optional Safety Enclosure.....	104
11042 Automatic Rotary Tool Changer.....	107



Cutting Tools

Boring Tools

650-2-1D Blind Hole Cutterhead Kit, 2.0-4.0" (51-102mm) x 7" (176mm)

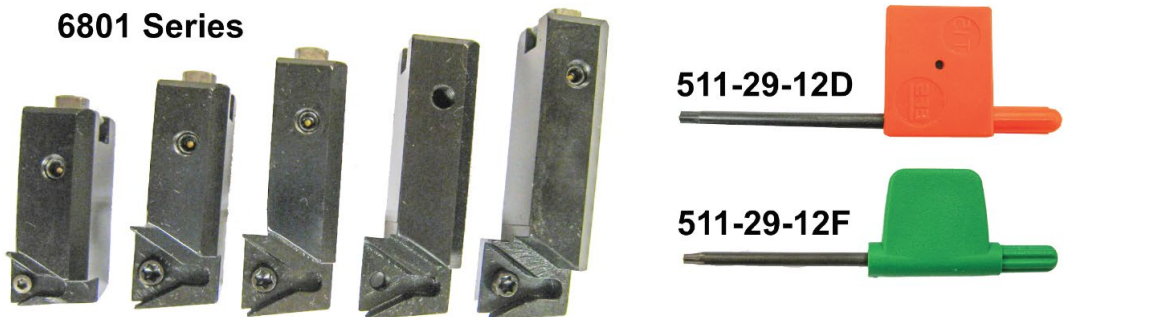

		Tool Diameter Range						
Cutterhead Diameter	Centerline Offset		6801A	6801B	6801C	6801D	6801E	6801F
1.86"	-0.638"	Min	1.52"	1.95"	2.32"	2.71"	3.12"	3.52"
		Max	2.04"	2.55"	2.92"	3.31"	3.72"	4.12"

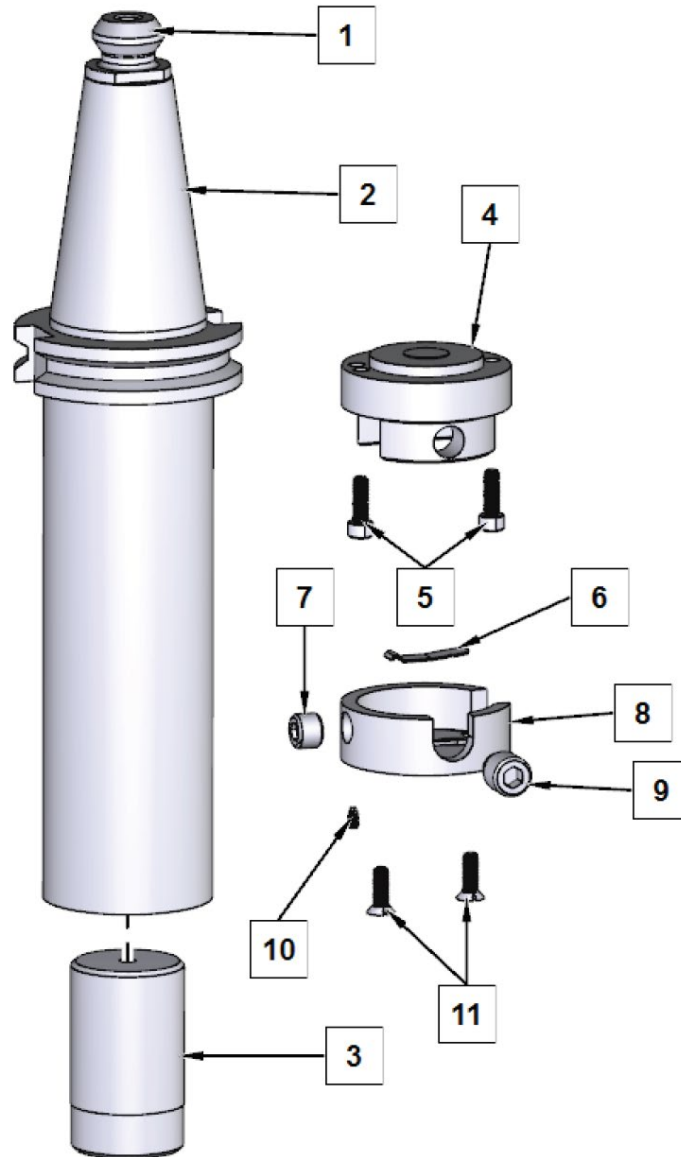

650-2-1E CUTTERHEAD ASSEMBLY			
ITEM	QTY	PART NUMBER	DESCRIPTION
1	1	650-2-44L	CAT 40 RETENTION KNOB
2	1	650-2-3N	ADAPTER, 2.0" STUB BAR, CAT 40 TAPER
3	1	650-2-5	COUNTERWEIGHT, 2.0" STUB BAR
4	1	650-2-4	BODY, 2.0" STUB BAR
5	2	650-2-4A	SOCKET HEAD CAPSCREW #8-32 X 1/2"
6	1	100-1B	SPRING, TOOL LOCK 15/16"
7	1	502-2-85B	SET SCREW, INDEX, 3/8-40
8	1	650-2-6	CAP, 2.0" STUB BAR
9	1	501-70C	SCREW, TOOL HOLDER, LOCK
10	1	650-2-6A	SOCKET SET SCREW, BRASS TIPPED, #4-40 X 3/16"
11	2	MF-123	SOCKET FLAT HEAD SCREW, #8-32 X 1/2"

650-2-3T Blind Hole Cutterhead Kit, 2.0-4.0" (51-102mm) x 4.0" (102mm)

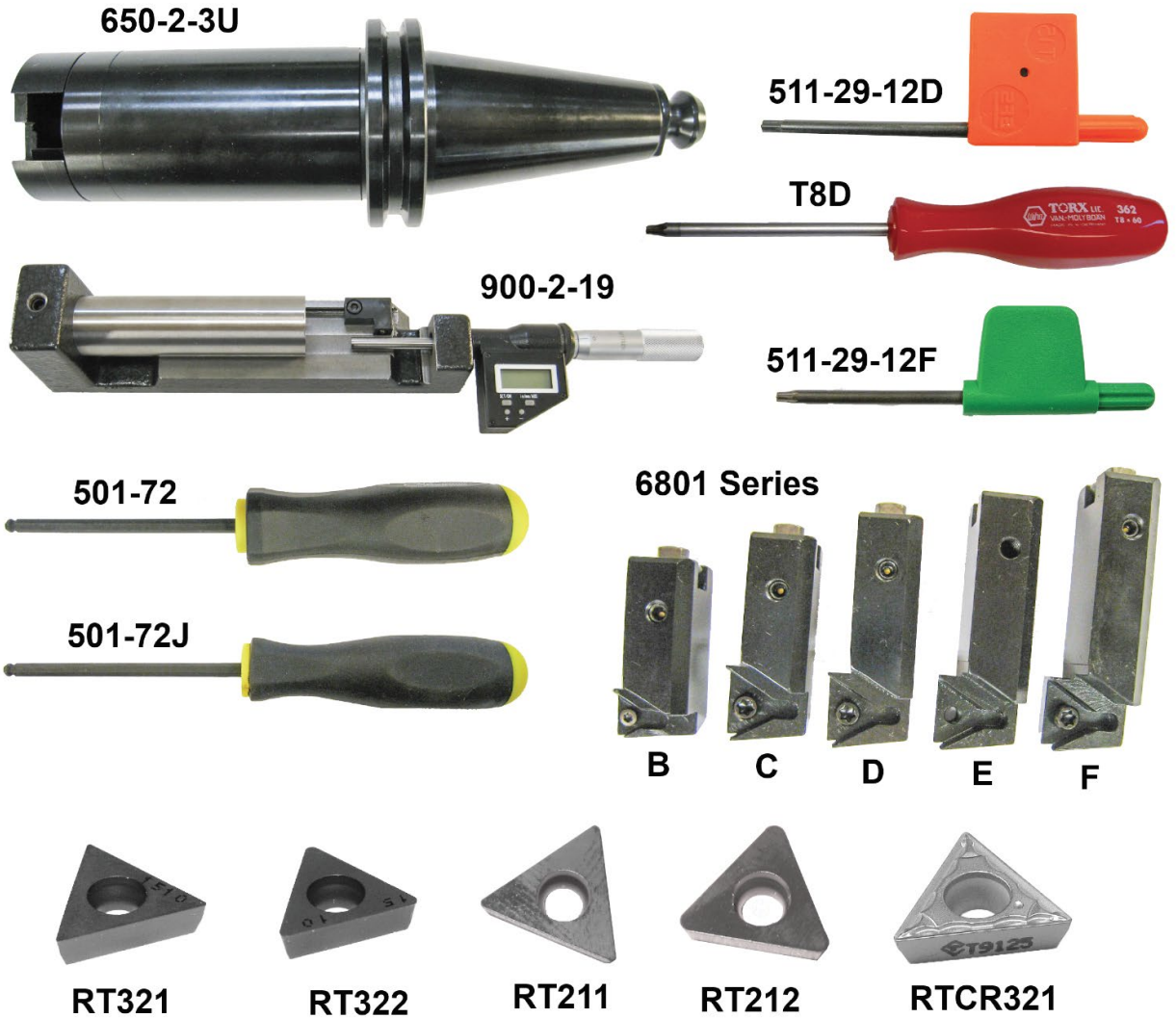

		Tool Diameter Range						
Cutterhead Diameter	Centerline Offset		6801A	6801B	6801C	6801D	6801E	6801F
1.86"	-0.638"	Min	1.52"	1.95"	2.32"	2.71"	3.12"	3.52"
		Max	2.04"	2.55"	2.92"	3.31"	3.72"	4.12"

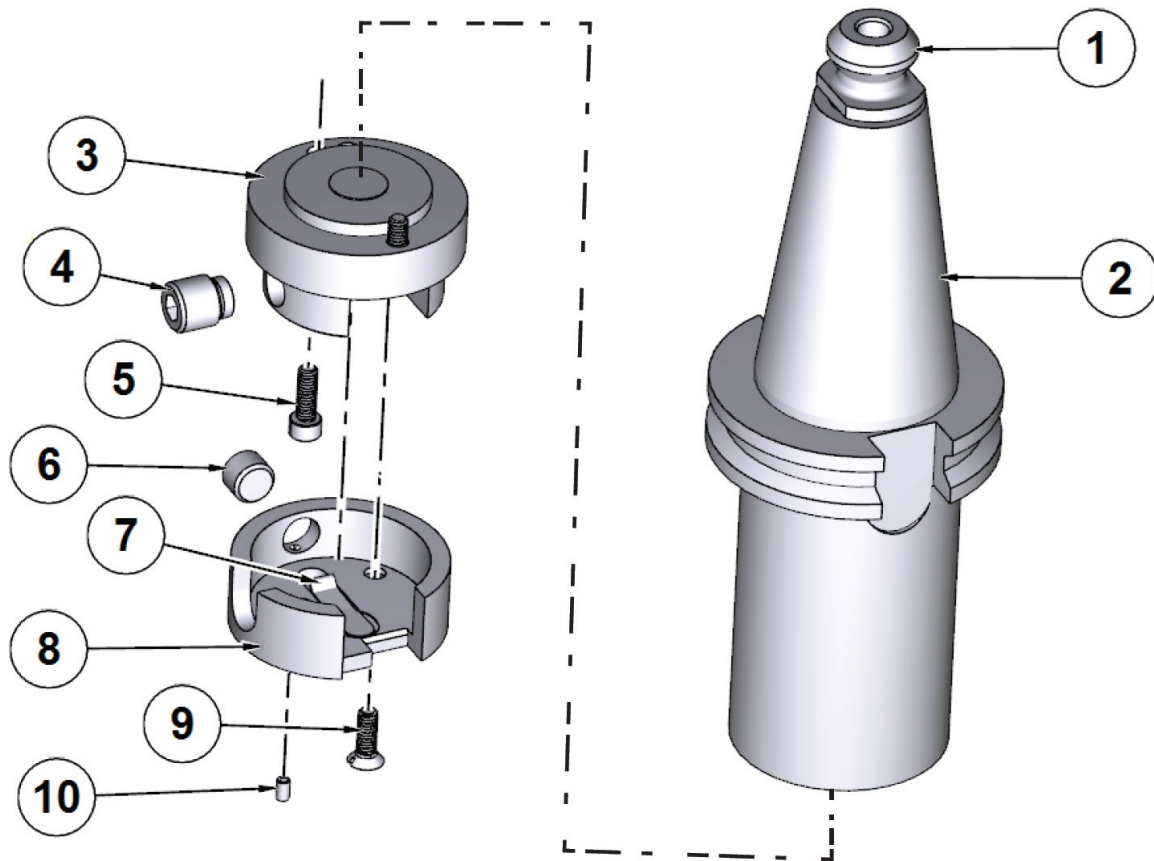

650-2-3U CUTTERHEAD ASSEMBLY			
ITEM	QTY	PART NUMBER	DESCRIPTION
1	1	650-2-44L	CAT 40 RETENTION KNOB
2	1	650-2-3P	ADAPTER, 2.0" STUB BAR, CAT 40, 4"
3	1	650-2-4	BODY, 2.0" STUB BAR
4	1	501-70C	SCREW, TOOL HOLDER LOCK
5	2	650-2-4A	SOCKET HEAD CAPSCREW #8-32 X 1/2"
6	1	502-2-85B	SOCKET SET SCREW, INDEX, 3/8-40
7	1	100-1B	SPRING, TOOL LOCK 15/16"
8	1	650-2-6	BODY, 2.0" STUB BAR
9	3	MF-123	SOCKET FLAT HEAD SCREW, #8-32 X 1/2"
10	1	650-2-6A	SOCKET SET SCREW, BRASS TIPPED, #4-40 X 3/16"

11100 Blind Hole Cutterhead Kit, 3.8-5.0" (96.5-127mm)

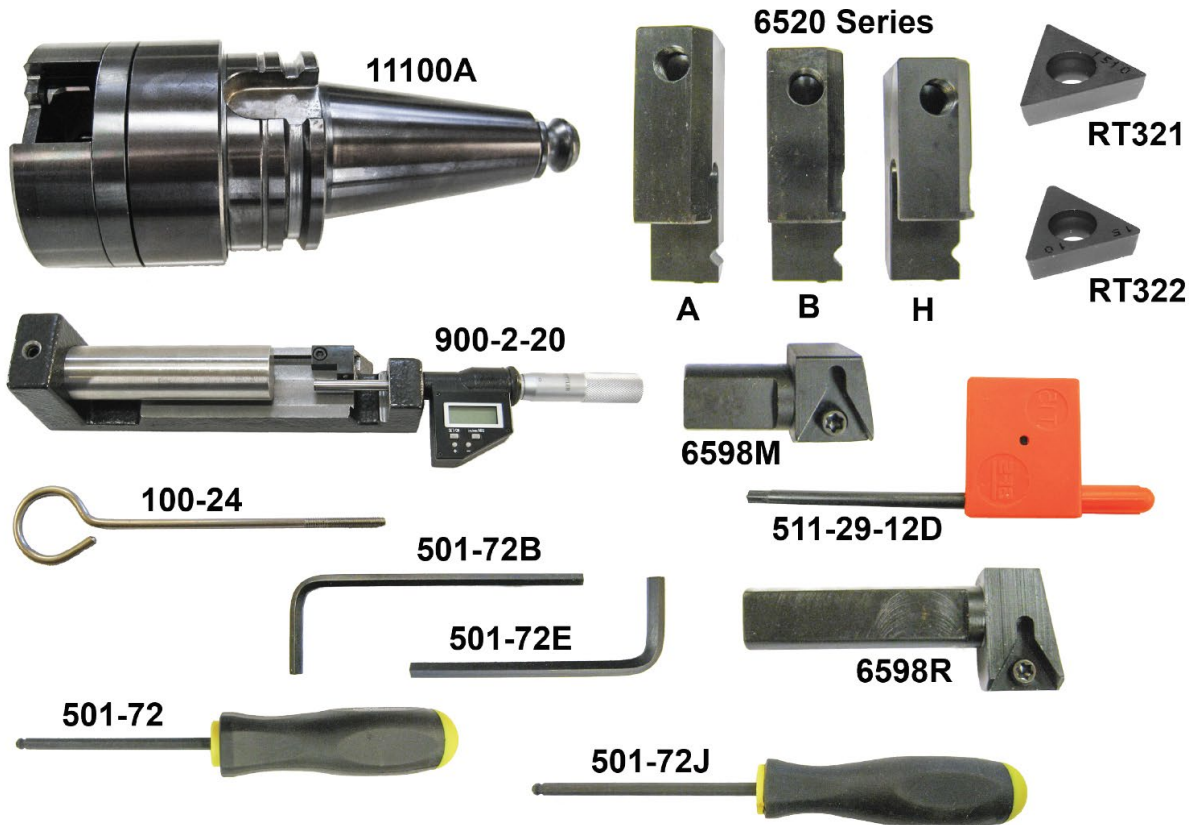

		Tool Diameter Range			
Cutterhead Diameter	Centerline Offset		6520A	6520B	6520H (6598M)
2.82"	-1.104"	Min	3.72"	5.55"	3.46"
		Max	4.22"	6.72"	3.86"

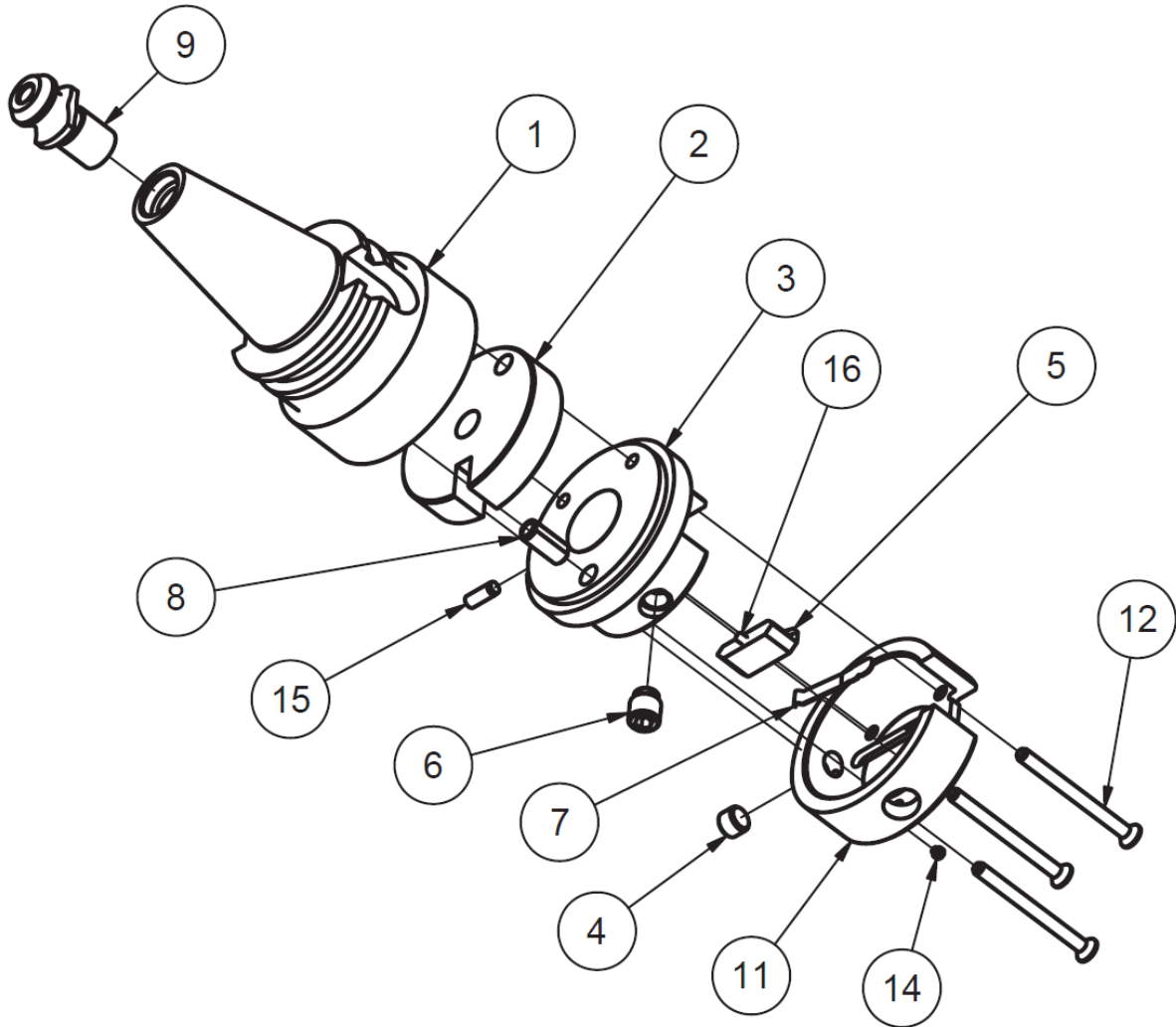

11100A CUTTERHEAD ASSEMBLY			
ITEM	QTY	PART NUMBER	DESCRIPTION
1	1	11100B	ADAPTER, 3.8" CUTTERHEAD, CAT 40
2	1	6521	COUNTERWEIGHT
3	1	650-2-16	BODY, 2.9" STUB BAR
4	1	502-2-85B	INDEX SCREW
5	1	6263A	TOOL HOLDER CLAMP SCREW
6	1	501-70A	TOOL HOLDER LOCK SCREW ASS'Y
7	1	100-1A	TOOL OLCK SPRING
8	1	502-2-45B	BUSHING- COUNTERWEIGHT
9	1	650-2-44L	CAT 40 RETENTION KNOB
11	1	650-2-17	CAP, 2.9" STUB BAR
12	3	MF-81C	SOCKET FLAT HEAD SCREW #10-24 X 2 1/4"
14	1	502-12-4D	SOCKET SET SCREW, BRASS TIPPED, #8-32 X 1/8"
15	1	MF-196	DOWEL PIN, 3/16 X 1/2"
16	1	MF-193C	DOWEL PIN, 1/8 X 3/8"

650-2-15F Blind Hole Cutterhead Kit, 2.9-8.0" (73.5-203mm) x 4.0" (102mm)



		Tool Diameter Range									
Cutterhead Diameter	Centerline Offset		6593C	6593D	6520H	6520A	6520B	6520C	6520D	6520E	6520F
2.82"	-1.104"	Min	2.90"	3.34"	3.46"	3.72"	5.55"	5.55"	5.55"	5.72"	6.22"
		Max	3.33"	3.77"	3.86"	4.22"	6.72"	7.32"	7.82"	8.32"	8.82"

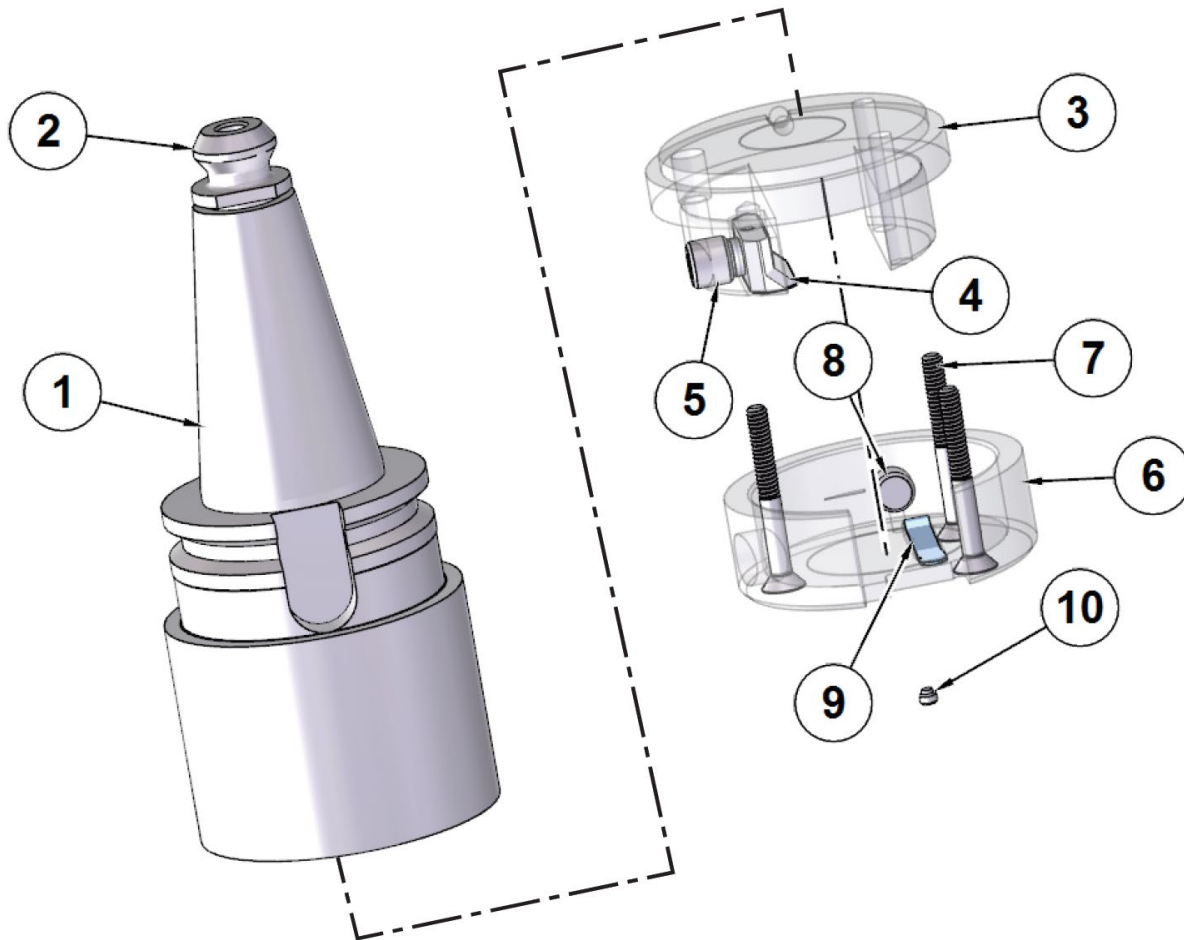

650-2-15G CUTTERHEAD ASSEMBLY PARTS			
ITEM	QTY	PART NUMBER	DESCRIPTION
1	1	650-2-15H	ADAPTER, 2.9" STUB BAR, CAT 40 TAPER
2	1	650-2-44L	CAT 40 RETENTION KNOB
3	1	650-2-16	BODY, 2.9" STUB BAR
4	1	6263A	SHOE, CLAMP – TOOL HOLDER
5	1	501-70C	SCREW, TOOL HOLDER LOCK
6	1	650-2-17	CAP, 2.9" STUB BAR
7	3	MF-81D	SOCKET FLAT HEAD SCREW #10-24 X 1 3/4"
8	1	502-2-85B	SOCKET SET SCREW, INDEX, 3/8-40
9	1	100-1A	SPRING, TOOL LOCK, 1 13/32"
10	1	502-12-4D	SOCKET SET SCREW, BRASS TIPPED, #8-32 X 1/8"

650-2-14B Blind Hole Cutterhead Kit, 2.9-8.0" (73.5-203mm) x 7" (176mm)



		Tool Diameter Range									
Cutterhead Diameter	Centerline Offset		6593C	6593D	6520H	6520A	6520B	6520C	6520D	6520E	6520F
2.82"	-1.104"	Min	2.90"	3.34"	3.46"	3.72"	5.55"	5.55"	5.55"	5.72"	6.22"
		Max	3.33"	3.77"	3.86"	4.22"	6.72"	7.32"	7.82"	8.32"	8.82"

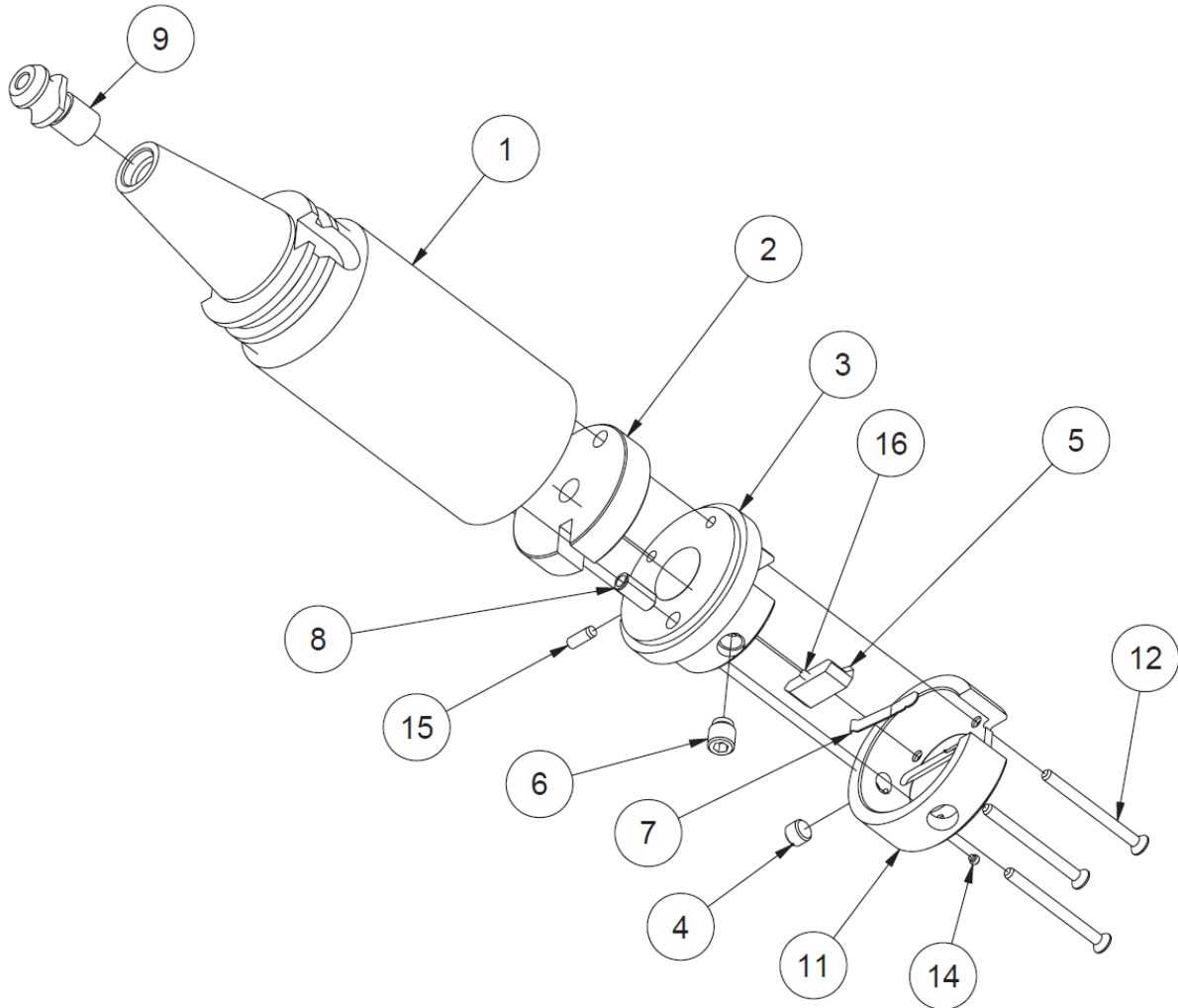

650-2-14C CUTTERHEAD ASSEMBLY			
ITEM	QTY	PART NUMBER	DESCRIPTION
1	1	650-2-15E	ADAPTER, 2.9" STUB BAR, CAT 40 TAPER
2	1	6521	COUNTERWEIGHT
3	1	650-2-16	BODY, 2.9" STUB BAR
4	1	502-2-85B	INDEX SCREW
5	1	6263A	TOOL HOLDER CLAMP SCREW
6	1	501-70A	TOOL HOLDER LOCK SCREW ASS'Y
7	1	100-1A	TOOL LOCK SPRING
8	1	502-2-45B	BUSHING – COUNTERWEIGHT
9	1	650-2-44L	CAT 40 RETENTION KNOB
11	1	650-2-17	CAP, 2.9" STUB BAR
12	3	MF-81C	SOCKET FLAT HEAD SCREW, #10-24 X 2 1/4"
14	1	502-12-4D	SOCKET SET SCREW, BRASS TIPPED, #8-32 X 1/8"
15	1	MF-196	DOWEL PIN 3/16 X 1/2"
16	1	MF-193C	DOWEL PIN 1/8 X 3/8"

11101 HD Cutterhead Kit, 4.5-7.0" (115-178mm)

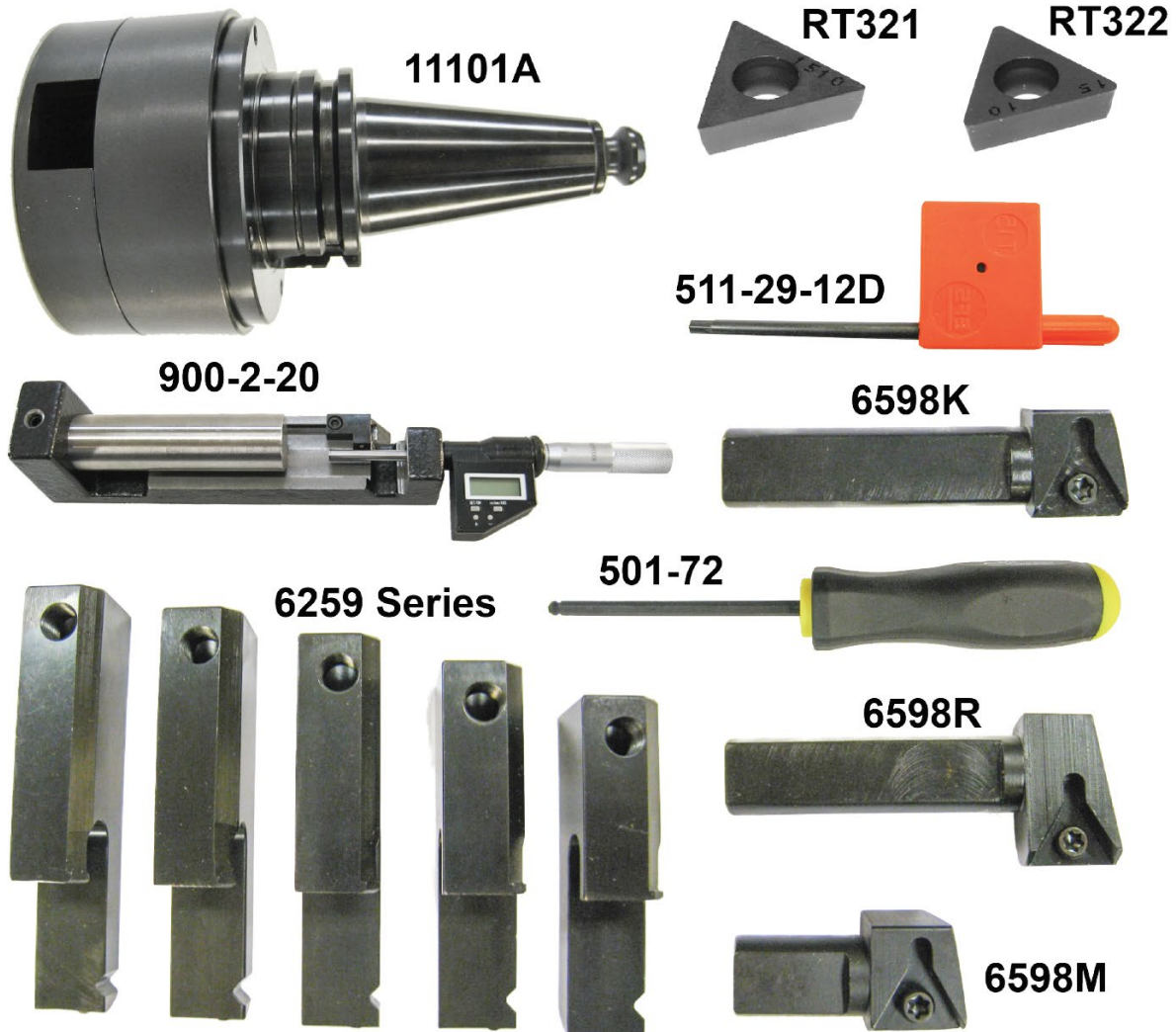

Cutterhead Body Diameter	Centerline Offset	Tool Diameter Range							
			6259P	6259C	6259D	6259I	6259E	6259F	6259G
4.125" 104.78mm	-1.7625" 44.77mm	Min	4.205" 106.81mm	4.615" 117.22mm	5.205" 132.21mm	5.685" 144.40mm	6.185" 157.10mm	7.145" 181.48mm	8.175" 207.65mm
		Max	6.445" 163.70mm	6.875" 174.63mm	7.455" 189.36mm	7.935" 201.55mm	8.435" 214.25mm	9.395" 238.63mm	10.425" 264.80mm

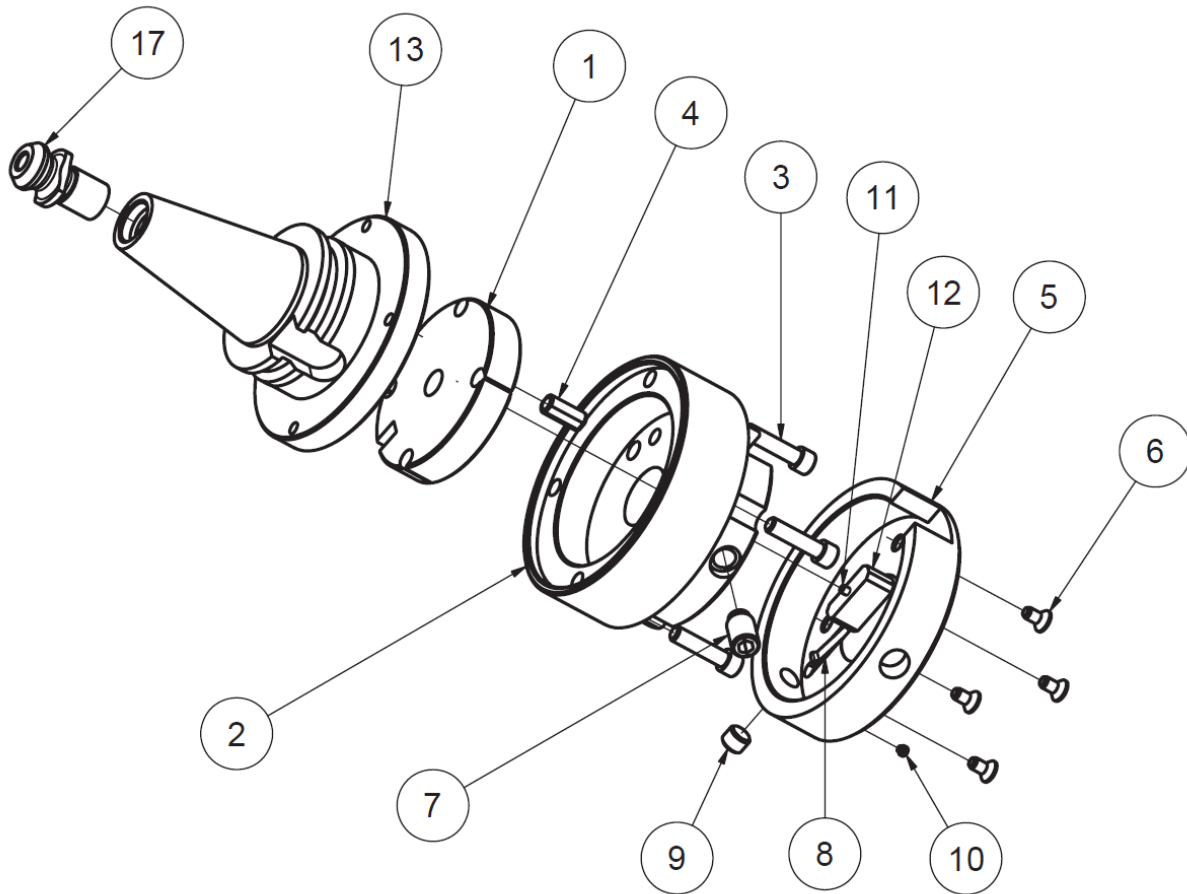

11101A CUTTERHEAD ASSEMBLY			
ITEM	QTY	PART NUMBER	DESCRIPTION
1	1	600-20-11	COUNTERWEIGHT
2	1	6256L	BODY, CUTTERHEAD 4.50"
3	4	MF-15	SOCKET HEAD CAPSCREW 1/4-20 X 1"
4	1	502-2-45B	BUSHING – COUNTERWEIGHT
5	1	6256N	CAP, CUTTERHEAD, 4.50"
6	4	MF-78	SOCKET FLAT HEAD SCREW, #10-24 X 3/8"
7	1	501-70	TOOL HOLDER LOCK SCREW ASS'Y
8	1	100-1E	TOOL LOCK SPRING
9	1	502-2-85B	INDEX SCREW
10	1	502-12-4D	SOCKET SET SCREW, BRASS TIPPED, #8-32 X 1/8"
11	1	MF-193	DOWEL PIN 1/8 X 1/2"
12	1	6263B	CLAMP SHOE, TOOL HOLDER
13	1	11101B	ADAPTER 4 1/2" CUTTERHEAD
17	1	650-2-44L	CAT 40 RETENTION KNOB

Surfacing Tools

650-2-8E Surfacing Flycutter Kit, 10" (254mm) Dia

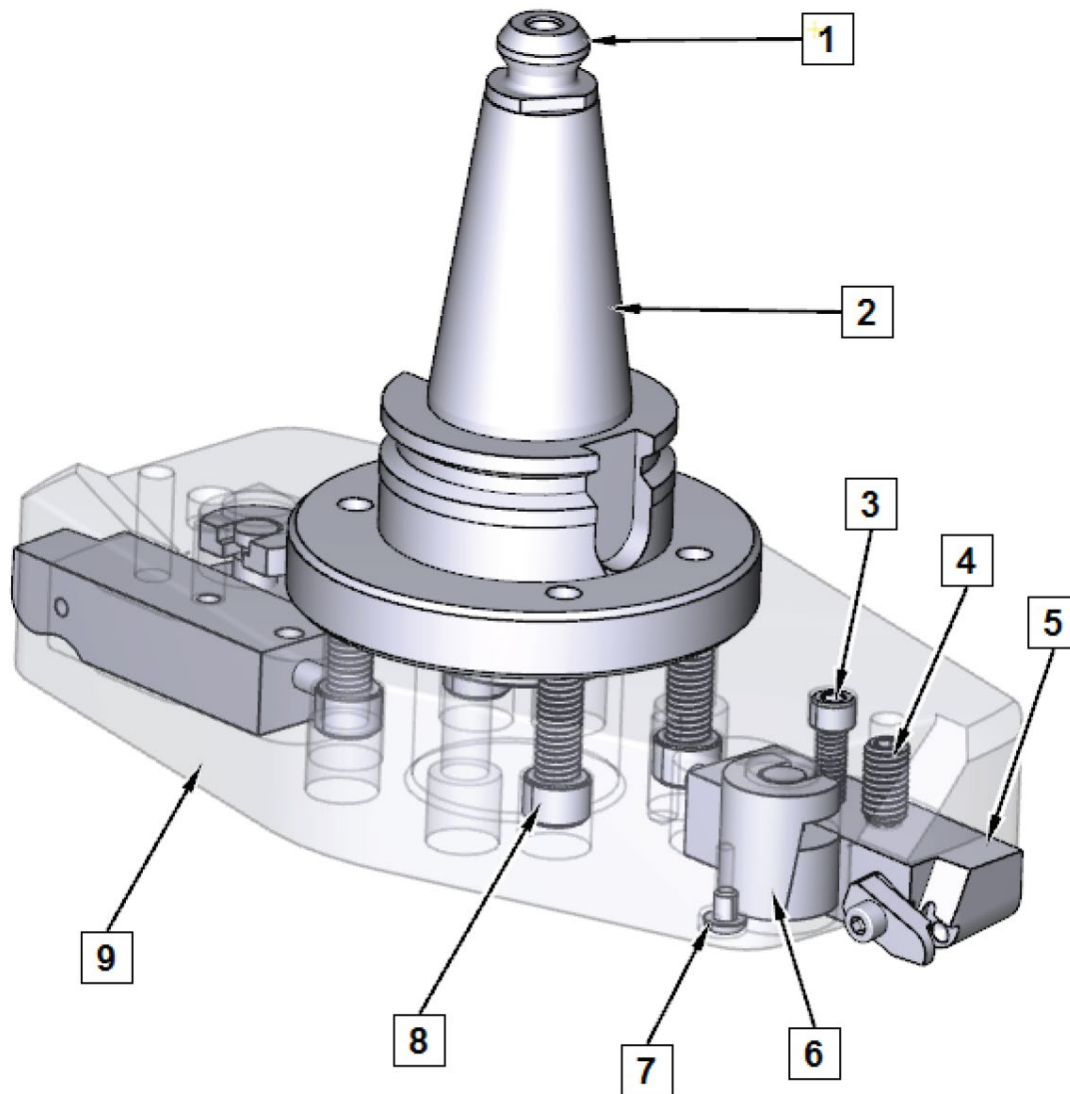

650-2-8E 10" FLYCUTTER ASSEMBLY – CAT 40			
ITEM	QTY	PART NUMBER	DESCRIPTION
1	1	650-2-44L	CAT 40 RETENTION KNOB
2	1	650-2-7E	ADAPTER, 10" AND 14" FLYCUTTER, CAT 40 TAPER
3	2	MF-15	SOCKET HEAD CAPSCREW 1/4-20 X 1"
4	2	7202C	SCREW, ADJUSTING, SURFACING CUTTERHEAD 3/8-16 X 3/8", OVAL POINT SET SCREW
5	2	7207W	TOOL HOLDER ASSEMBLY, FLY CUTTER
6	2	7206K	"L" LOCK – SURFACING CUTTERHEAD
7	2	MF-87	SOCKET BUTTON HEAD SCREW #10-24 X 1/4"
8	4	MF-33	SOCKET HEAD CAPSCREW 3/8-16 X 1 1/2"
9	1	7206L	CUTTERHEAD, SURFACING 10 1/4"

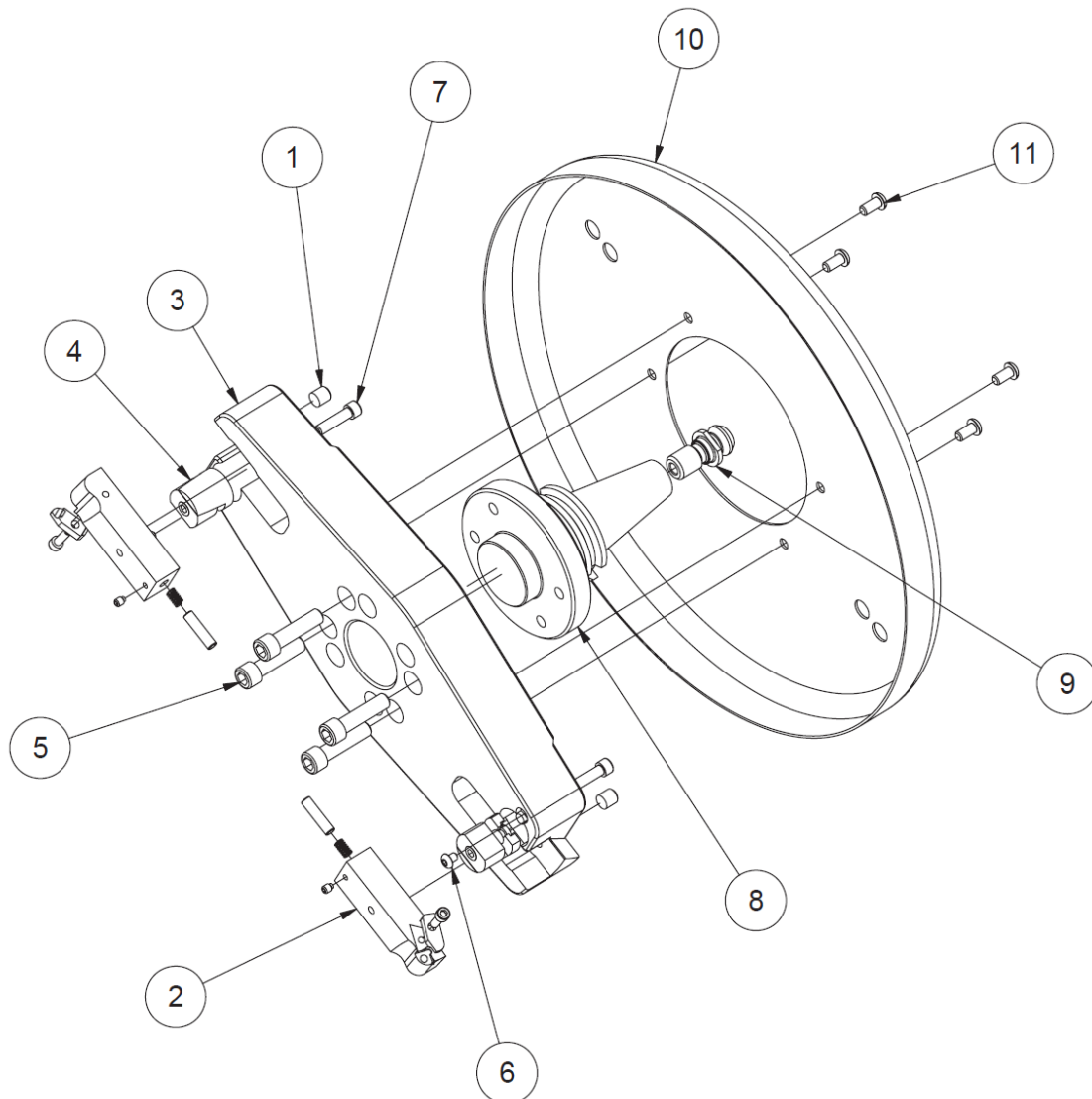
650-2-8F Surfacing Flycutter Kit, 14" (356mm) Dia

650-2-8F 14" FLYCUTTER ASSEMBLY – CAT 40			
ITEM	QTY	PART NUMBER	DESCRIPTION
1	2	7202C	SCREW, ADJUSTING, SURFACING CUTTERHEAD $\frac{3}{8}$ -16 X $\frac{3}{8}$ ", OVAL POINT SET SCREW
2	2	7202W	TOOL HOLDER ASSEMBLY, FLY CUTTER
3	1	7206G	MILLING CUTTERHEAD, 14" DIA. W/ $\frac{3}{4}$ X 1" TOOL HOLDER
4	2	7206K	"L" LOCK – SURFACING CUTTERHEAD
5	4	MF-33	SOCKET HEAD CAPSCREW $\frac{3}{8}$ -16 X 1 $\frac{1}{2}$ "
6	2	MF-87	SOCKET BUTTON HEAD SCREW #10-24 X $\frac{1}{4}$ "
7	2	MF-15	SOCKET HEAD CAPSCREW $\frac{1}{4}$ -20 X 1"
8	1	650-2-7E	ADAPTER, 10" AND 14" FLYCUTTER, CAT 40 TAPER
9	1	650-2-44L	CAT 40 RETENTION KNOB
10	1	650-2-8D	SHROUD, SURFACING CUTTERHEAD, 14"
11	4	MF-90	SOCKET BUTTON HEAD SCREW $\frac{1}{4}$ -20 X $\frac{1}{2}$ "

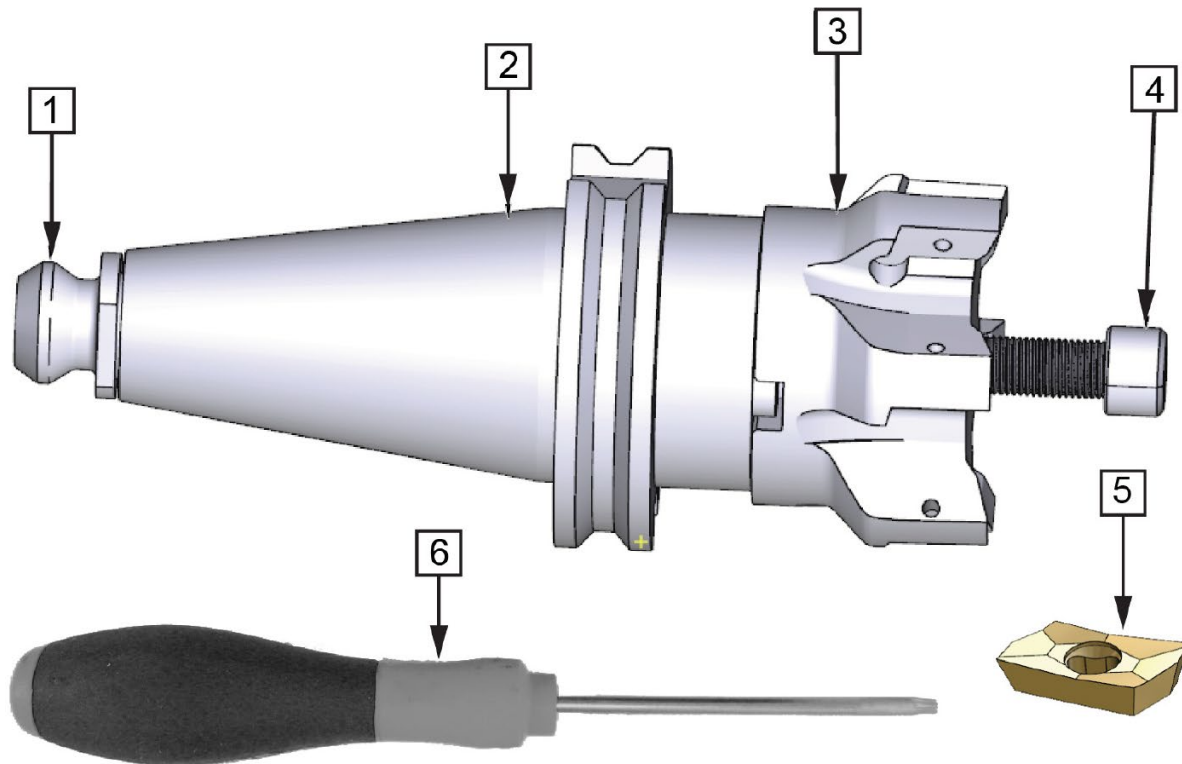
650-2-44N Shell Mill Parts, 2 1/2" (63.5mm) Dia

650-2-44N 2 1/2" SHELL MILL ASSEMBLY – CAT 40			
ITEM	QTY	PART NUMBER	DESCRIPTION
1	1	650-2-44L	CAT 40 RETENTION KNOB
2	1	650-2-44G	ADAPTER FOR SHELL MILLS, 3/4" BORE
3	1	7224E	SHELL MILL, 2 1/2"
4	1	7224D	SOCKET HEAD CAPSCREW 3/8-24 X 1"
5	7	6514T	INSERT, SHELL MILLS, 18mm 0.03 (0.8mm)
6	1	T15D	T15 TOX TIP SCREW DRIVER

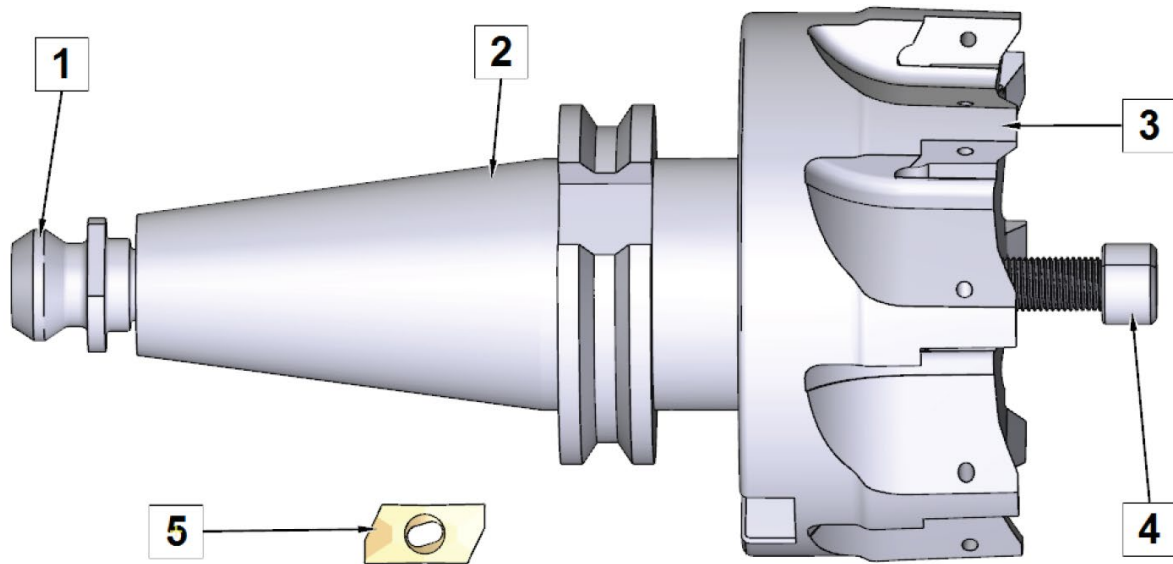
650-2-44P Shell Mill Parts, 4" (101.60mm) Dia

650-2-44P 4" SHELL MILL ASSEMBLY – CAT 40			
ITEM	QTY	PART NUMBER	DESCRIPTION
1	1	650-2-44L	CAT 40 RETENTION KNOB
2	1	650-2-44F	ADAPTER FOR SHELL MILLS, 1 1/2" BORE
3	1	7224F	SHELL MILL, 4"
4	1	7224D	SOCKET HEAD CAPSCREW 3/8"-24 X 1"
5	8	6514T	INSERT, SHELL MILLS 18mm 0.03" (0.8mm)

Right Angle Drives

11103 Right Angle Drive Assembly

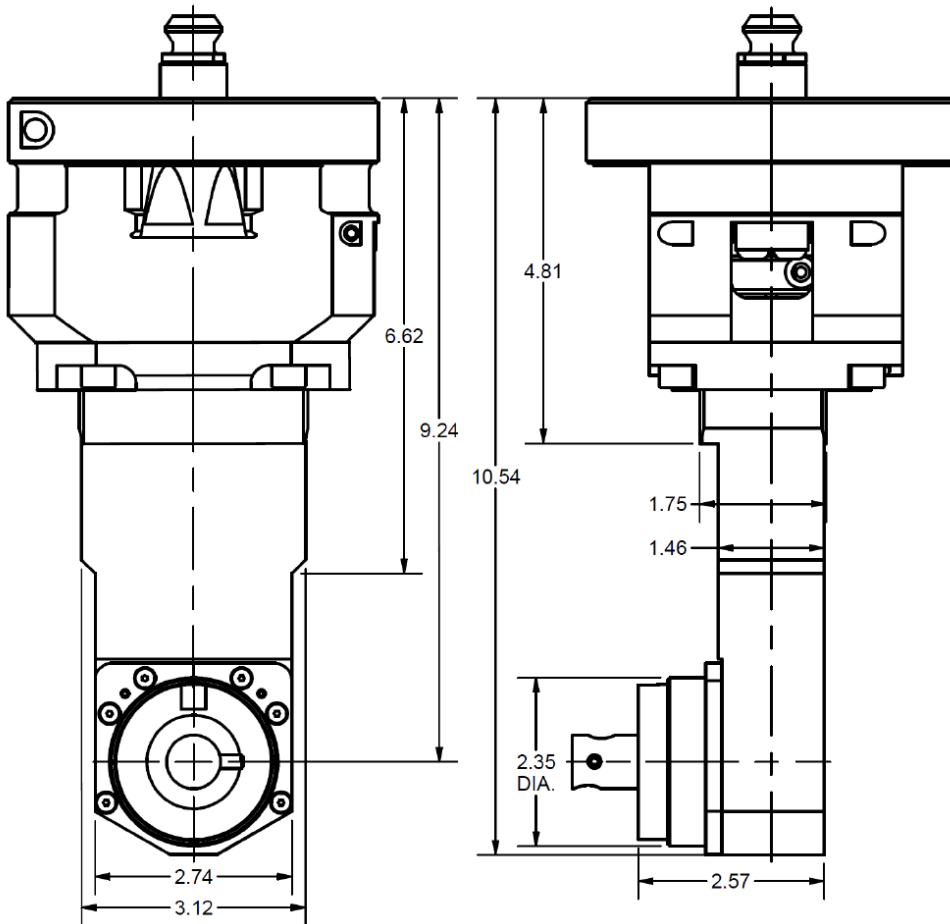
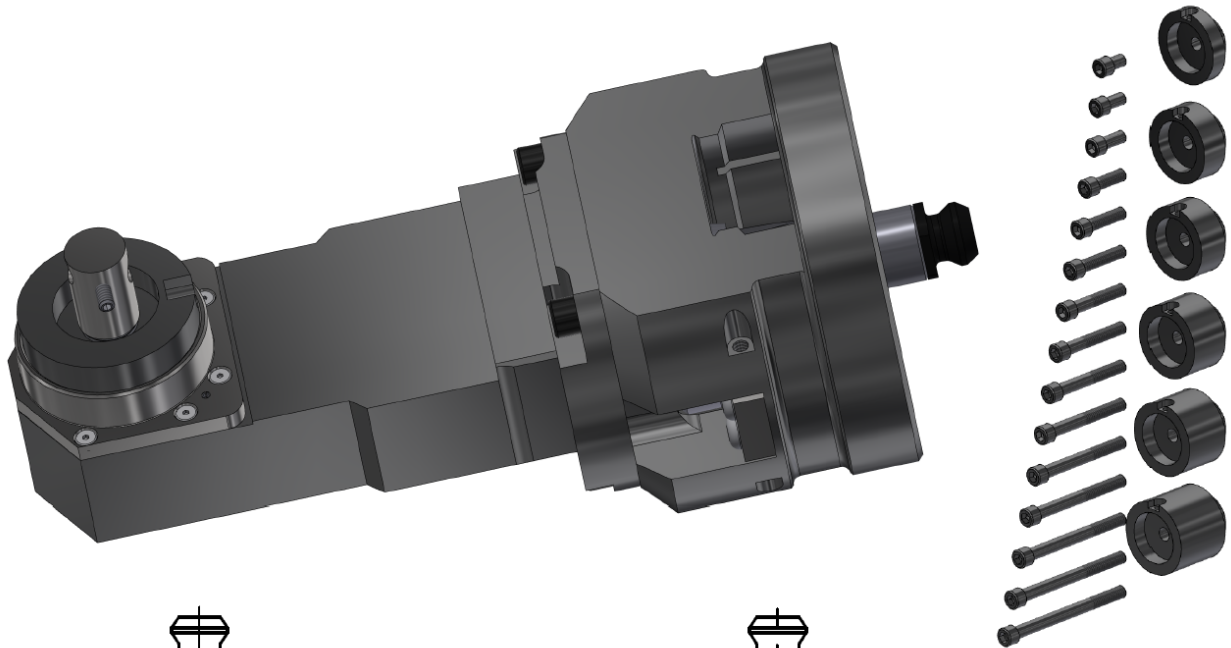

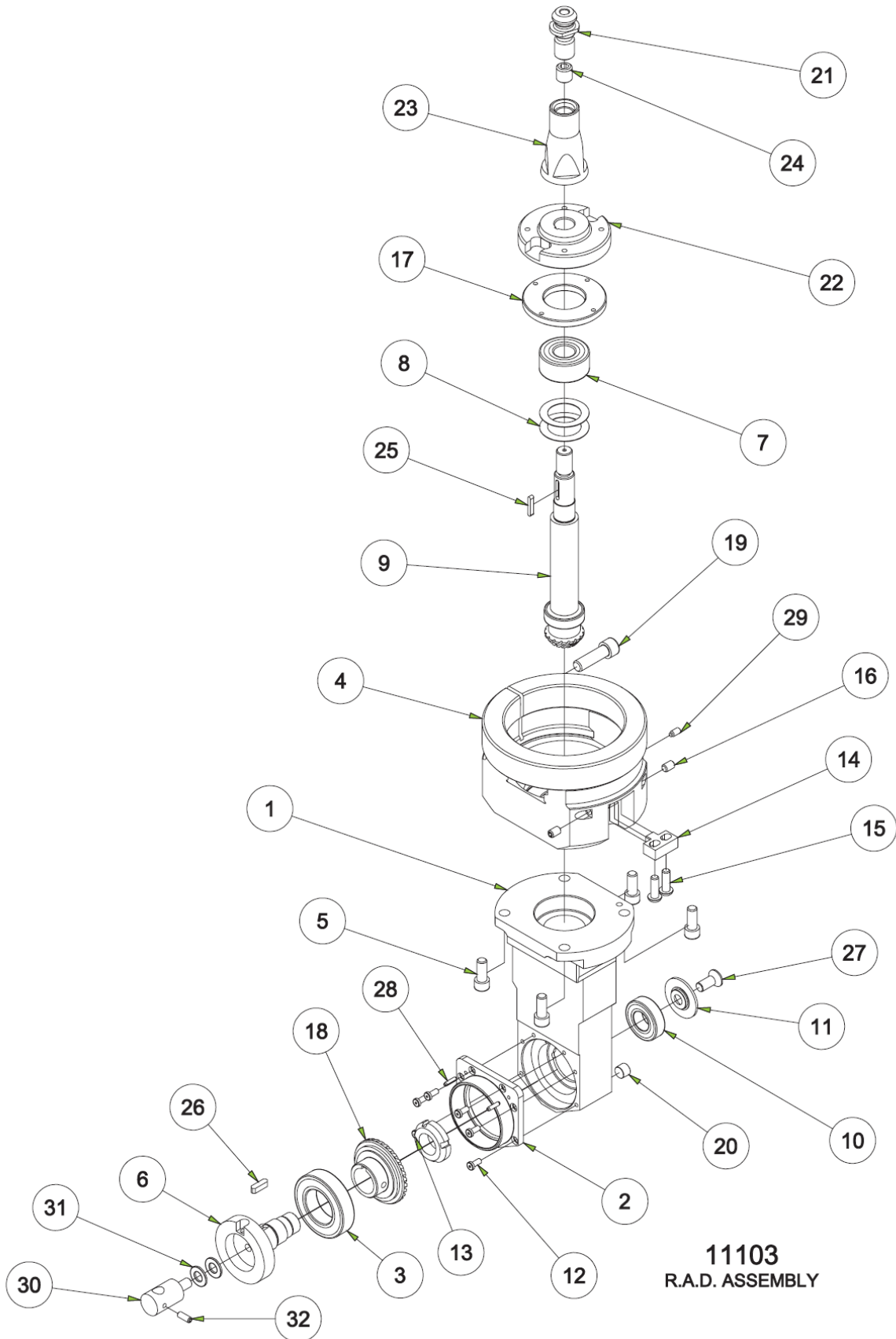

11103
R.A.D. ASSEMBLY



11103 RIGHT ANGLE DRIVE ASSEMBLY – CAT 40			
ITEM	QTY	PART NUMBER	DESCRIPTION
1	1	6773C	HOUSING, GEAR LINE, BORE HEAD
2	1	6774	COVER, BEARING RETAINER
3	1	502-9-72B	BALL BEARING
4	1	11103A	HUB, MOUNTING, R.A.D. ASSEMBLY
5	4	MF-22	SOCKET HEAD CAPSCREW 5/16-18 X 3/4"
6	1	650-2-42A	SHAFT, HORIZONTAL – INTERMEDIATE PREC. LINE BORE HEAD
7	1	502-9-32	BALL BEARING
8	2	6007A	BELLVILLE SPRING
9	1	6775A	PINON AND SHAFT ASSEMBLY – LINE BORE HEAD
10	1	6753E	BALL BEARING
11	1	6766F	END CAP
12	6	6774E	SOCKET HEAD CAPSCREW #8-32 X 3/8"
13	1	6705B	BEARING LOCK NUT
14	1	6750K	KEY, LOCATING, 90 DEG HEAD
15	2	MF-92	SOCKET BUTTON HEAD SCREW 1/4-20 X 3/4"
16	2	MF-59	SOCKET SET SCREW, FLAT POINT, 1/4-20 X 3/8"
17	1	6772A	NUT, BEARING, LINE BORE HEAD
18	1	6766H	RING GEAR REWORK – SMALL 90 DEG. R.A.D.
19	1	MF-32	SOCKET HEAD CAPSCREW 3/8-16 X 1 1/4"
20	1	MF-233	HEX SOCKET PLUG, 1/8" NPT
21	1	650-2-44L	CAT 40 RETENTION KNOB
22	1	11103B	DRIVER, F70 LINE BORE HEAD
23	1	11103C	MOUNT, RETENTION KNOB, R.A.D.
24	1	11103D	LOCKING SET SCREW, 1/2-13 X 1/2"
25	1	6753V	KEY (MICARTA), PINON – 90 DEG HEAD
26	1	7088A	KEY, PULLEY SF-1
27	1	6774K	SOCKET FLAT HEAD SCREW 5/16-24 X 3/4"
28	2	MF-217	ROLL PIN 1/8 X 1/2"
29	1	100-82-2A	SOCKET SET SCREW, BRASS TIPPED, #10-24
30	1	502-9-9S	INDICATOR MOUNT, R.A.D.
31	2	MF-177	SAE FLAT WASHER, 5/16"
32	1	MF-58A	SOCKET FLAT HEAD SCREW #10-24 X 1/2"

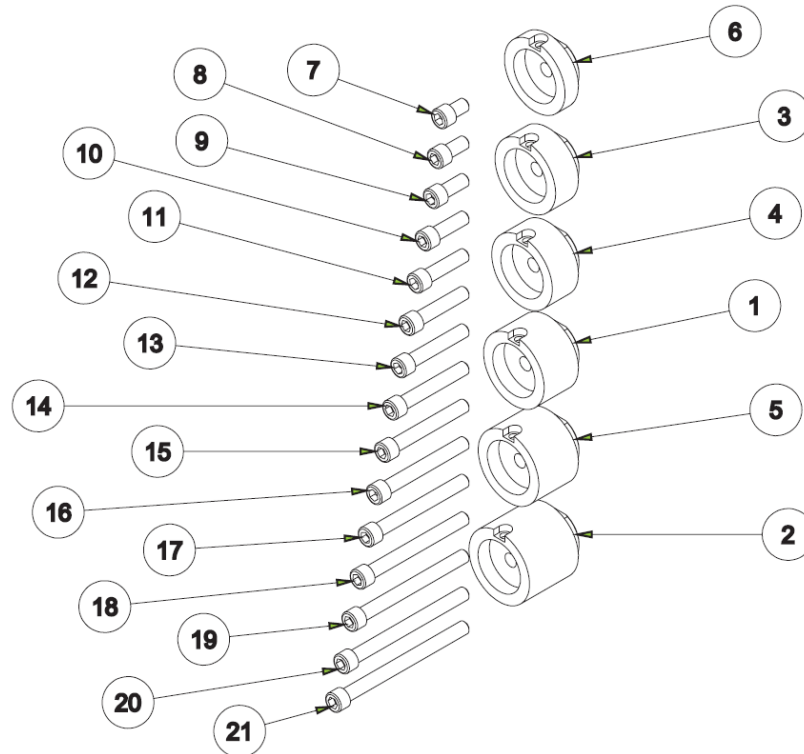

SPACER SET – R.A.D. ASSEMBLIES			
ITEM	QTY	PART NUMBER	DESCRIPTION
1	1	650-2-43	SPACER (1.05" LG.) PRECISION LINE BORE HEAD
2	1	650-2-43A	SPACER (1.50" LG.) PRECISION LINE BORE HEAD
3	1	650-2-43B	SPACER (0.70" LG.) PRECISION LINE BORE HEAD
4	1	650-2-43G	SPACER (0.80" LG.) PRECISION LINE BORE HEAD
5	1	650-2-43D	SPACER (1.215" LG.) PRECISION LINE BORE HEAD
6	1	650-2-43E	SPACER (0.41" LG.) PRECISION LINE BORE HEAD
7	1	MF-21A	SOCKET HEAD CAPSCREW 5/16-18 X 1/2"
8	1	MF-21	SOCKET HEAD CAPSCREW 5/16-18 X 5/8"
9	1	MF-22	SOCKET HEAD CAPSCREW 5/16-18 X 3/4"
10	1	MF-23	SOCKET HEAD CAPSCREW 5/16-18 X 1"
11	1	MF-24	SOCKET HEAD CAPSCREW 5/16-18 X 1 1/4"
12	1	MF-25	SOCKET HEAD CAPSCREW 5/16-18 X 1 1/2"
13	1	MF-26	SOCKET HEAD CAPSCREW 5/16-18 X 1 3/4"
14	1	MF-27	SOCKET HEAD CAPSCREW 5/16-18 X 2"
15	1	MF-27C	SOCKET HEAD CAPSCREW 5/16-18 X 2 1/4"
16	1	MF-27A	SOCKET HEAD CAPSCREW 5/16-18 X 2 1/2"
17	1	MF-28	SOCKET HEAD CAPSCREW 5/16-18 X 2 3/4"
18	1	MF-28E	SOCKET HEAD CAPSCREW 5/16-18 X 3"
19	1	MF-28F	SOCKET HEAD CAPSCREW 5/16-18 X 3 1/4"
20	1	MF-28A	SOCKET HEAD CAPSCREW 5/16-18 X 3 1/2"
21	1	MF-28G	SOCKET HEAD CAPSCREW 5/16-18 X 3 3/4"

11103E Right Angle Drive, 2" Extended

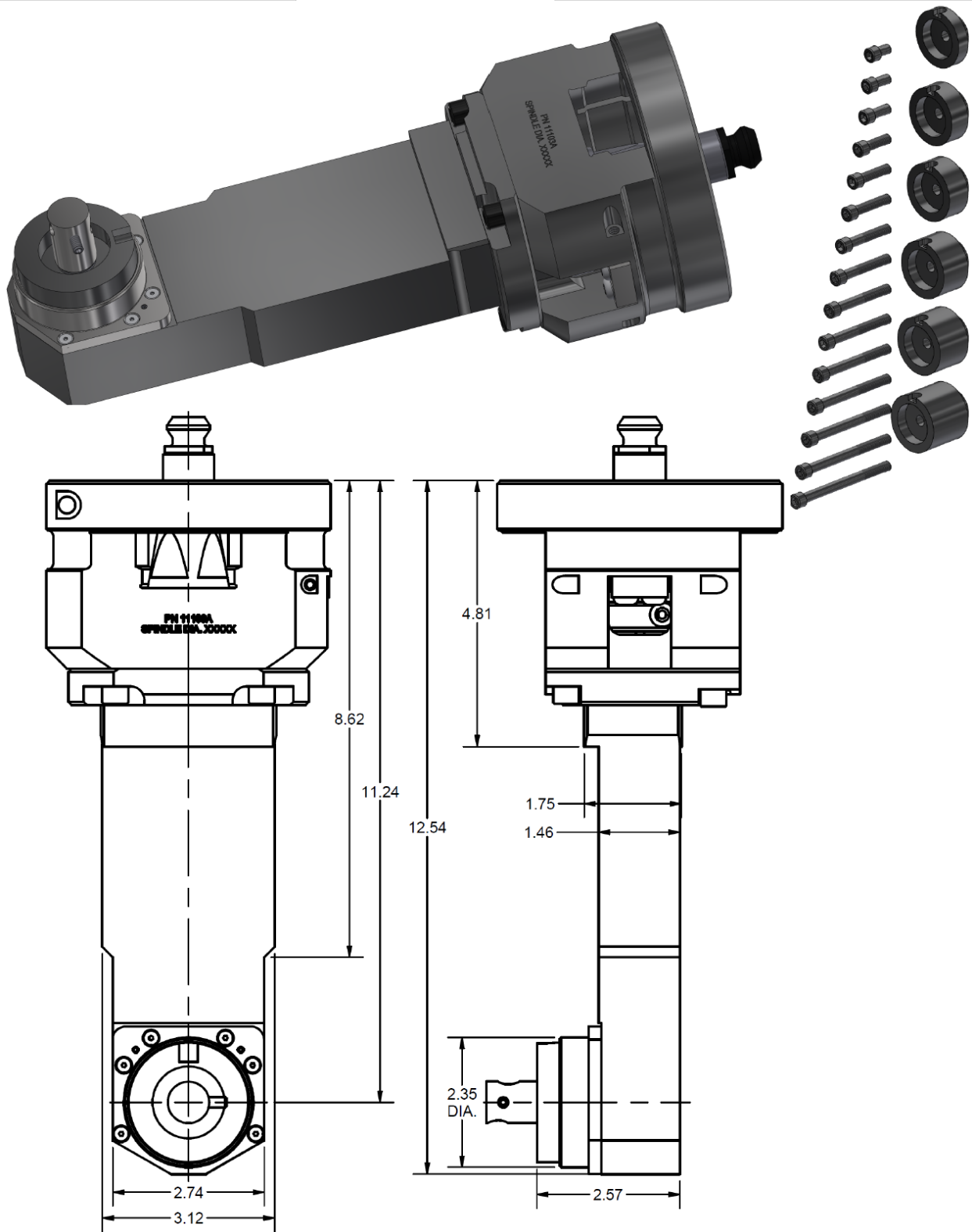

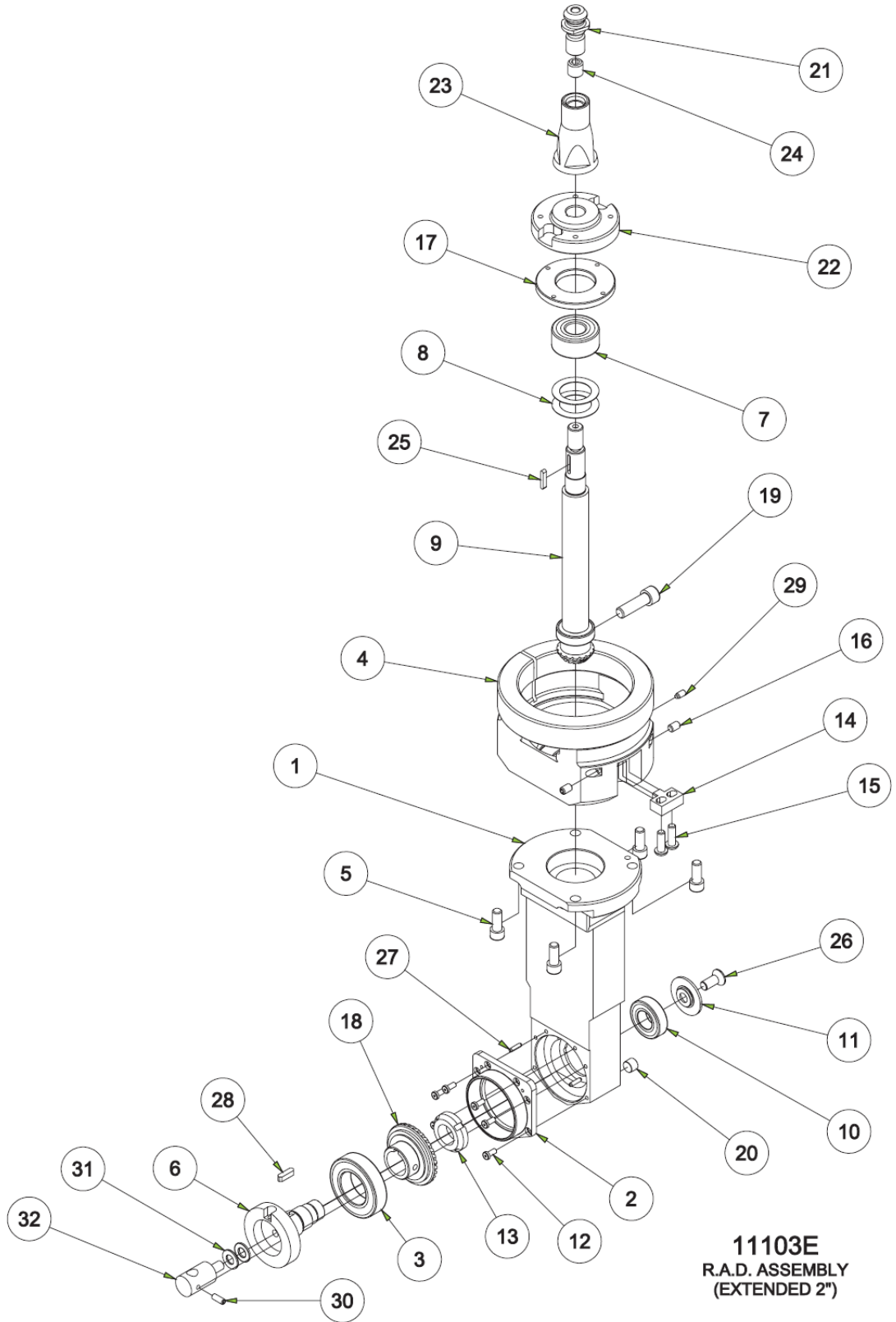



11103E RIGHT ANGLE DRIVE ASSEMBLY, 2" EXTENDED			
ITEM	QTY	PART NUMBER	DESCRIPTION
1	1	6773D	HOUSING, GEAR – RIGHT ANGLE DRIVE (EXTENDED)
2	1	6774	COVER, BEARING RETAINER
3	1	502-9-72B	BALL BEARING
4	1	11103A	HUB, MOUNTING, R.A.D. ASSEMBLY
5	4	MF-22	SOCKET HEAD CAPSCREW 5/16-18 X 3/4"
6	1	650-2-42A	SHAFT, HORIZONTAL – INTERMEDIATE PREC. LINE BORE HEAD
7	1	502-9-32	BALL BEARING
8	2	6007A	BELLVILLE SPRING
9	1	6775C	PINION AND SHAFT ASSEMBLY (2" EXT.) R.A.D.
10	1	6753E	BALL BEARING
11	1	6766F	ENG CAP
12	6	6774E	SOCKET HEAD CAPSCREW #8-32 X 3/8"
13	1	6705B	BEARING LOCK NUT
14	1	6750K	KEY, LOCATING, 90 DEG. HEAD
15	2	MF-92	SOCKET BUTTON HEAD SCREW 1/4-20 X 3/4"
16	2	MF-59	SOCKET SET SCREW, FLAT POINT, 1/4-20 X 3/8"
17	1	6772A	NUT, BEARING, LINE BORE HEAD
18	1	6766H	RING GEAR REWORK – SMALL 90 DEG. R.A.D.
19	1	MF-32	SOCKET HEAD CAPSCREW 3/8-16 X 1 1/4"
20	1	MF-233	HEX SOCKET PLUG, 1/8" NPT
21	1	650-2-44L	CAT 40 RETENTION KNOB
22	1	11103B	DRIVER, F70 LINE BORE HEAD
23	1	11103C	MOUNT, RETENTION KNOB, R.A.D.
24	1	11103D	LOCKING SET SCREW 1/2-13 X 1/2"
25	1	6753V	KEY (MICARTA), PINION – 90 DEG. HEAD
26	1	6774K	SOCKET FLAT HEAD SCREW 5/16-24 X 3/4"
27	2	MF-217	ROLL PIN 1/8 X 1/2"
28	1	7088A	KEY, PULLEY SF-1
29	1	100-82-2A	SOCKET SET SCREW, BRASS TIPPED, #10-24
30	1	MF-58A	SOCKET SET SCREW, FLAT POINT, #10-24 X 1/2"
31	2	MF-177	SAE FLAT WASHER 5/16"
32	1	502-9-9S	INDICATOR MOUNT, R.A.D.

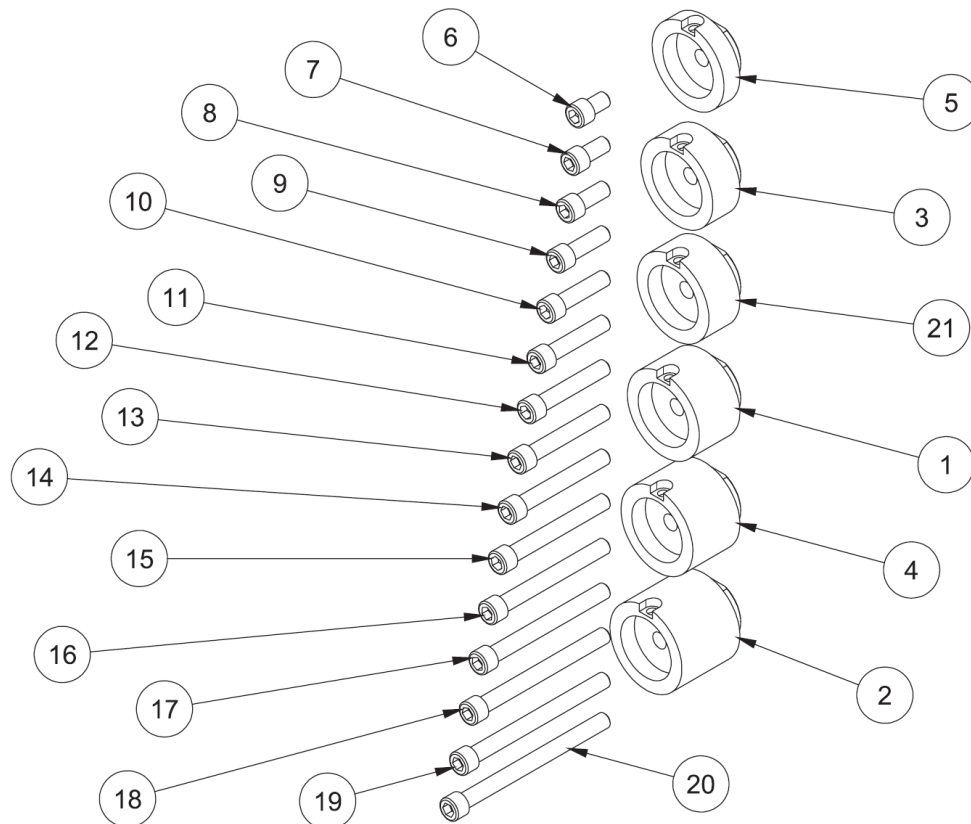

SPACER SET – R.A.D. ASSEMBLY, EM105H			
ITEM	QTY	PART NUMBER	DESCRIPTION
1	1	650-2-43	SPACER (1.05" LG) PRECISION LINE BORE HEAD
2	1	650-2-43A	SPACER (1.50" LG) PRECISION LINE BORE HEAD
3	1	650-2-43B	SPACER (.70" LG) PRECISION LINE BORE HEAD
4	1	650-2-43D	SPACER (1.215" LG) PRECISION LINE BORE HEAD
5	1	650-2-43E	SPACER (.41" LG) PRECISION LINE BORE HEAD
6	1	MF-21A	S.H.C.S 5/16-18 UNC X 1/2
7	1	MF-21	S.H.C.S 5/16-18 UNC X 5/8
8	1	MF-22	S.H.C.S 5/16-18 UNC X 3/4
9	1	MF-23	S.H.C.S 5/16-18 UNC X 1
10	1	MF-24	S.H.C.S 5/16-18 UNC X 1 1/4
11	1	MF-25	S.H.C.S 5/16-18 UNC X 1 1/2
12	1	MF-26	S.H.C.S 5/16-18 UNC X 1 3/4
13	1	MF-27	S.H.C.S 5/16-18 UNC X 2
14	1	MF-27C	S.H.C.S 5/16-18 UNC X 2 1/4
15	1	MF-27A	S.H.C.S 5/16-18 UNC X 2 1/2
16	1	MF-28	S.H.C.S 5/16-18 UNC X 2 3/4
17	1	MF-28E	S.H.C.S 5/16-18 UNC X 3
18	1	MF-28F	S.H.C.S 5/16-18 UNC X 3 1/4
19	1	MF-28A	S.H.C.S 5/16-18 UNC X 3 1/2
20	1	MF-28G	S.H.C.S 5/16-18 UNC X 3 3/4
21	1	650-2-43G	SPACER (.80" LG) PRECISION LINE BORE HEAD

11104 Special Belt Drive Right Angle Drive

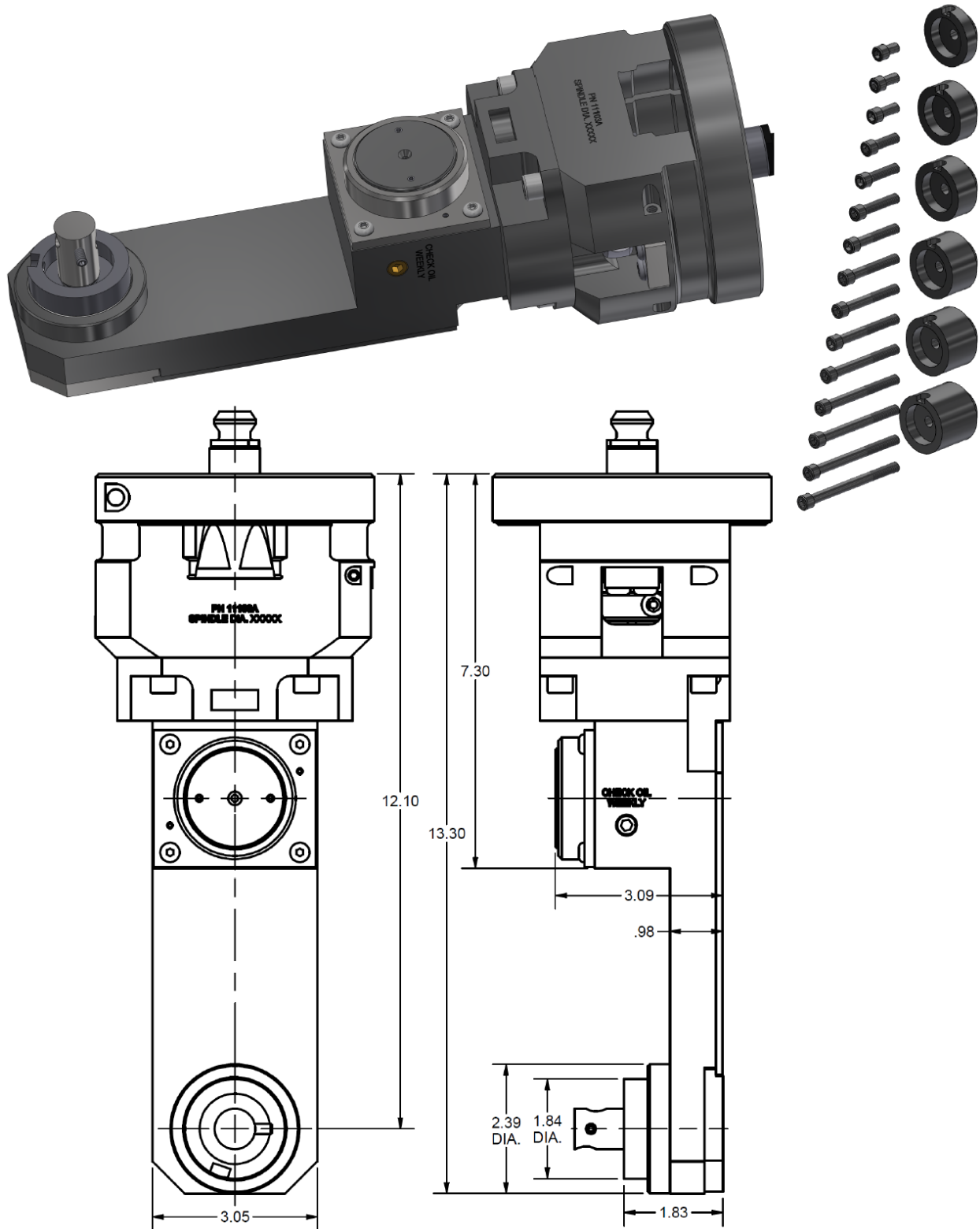

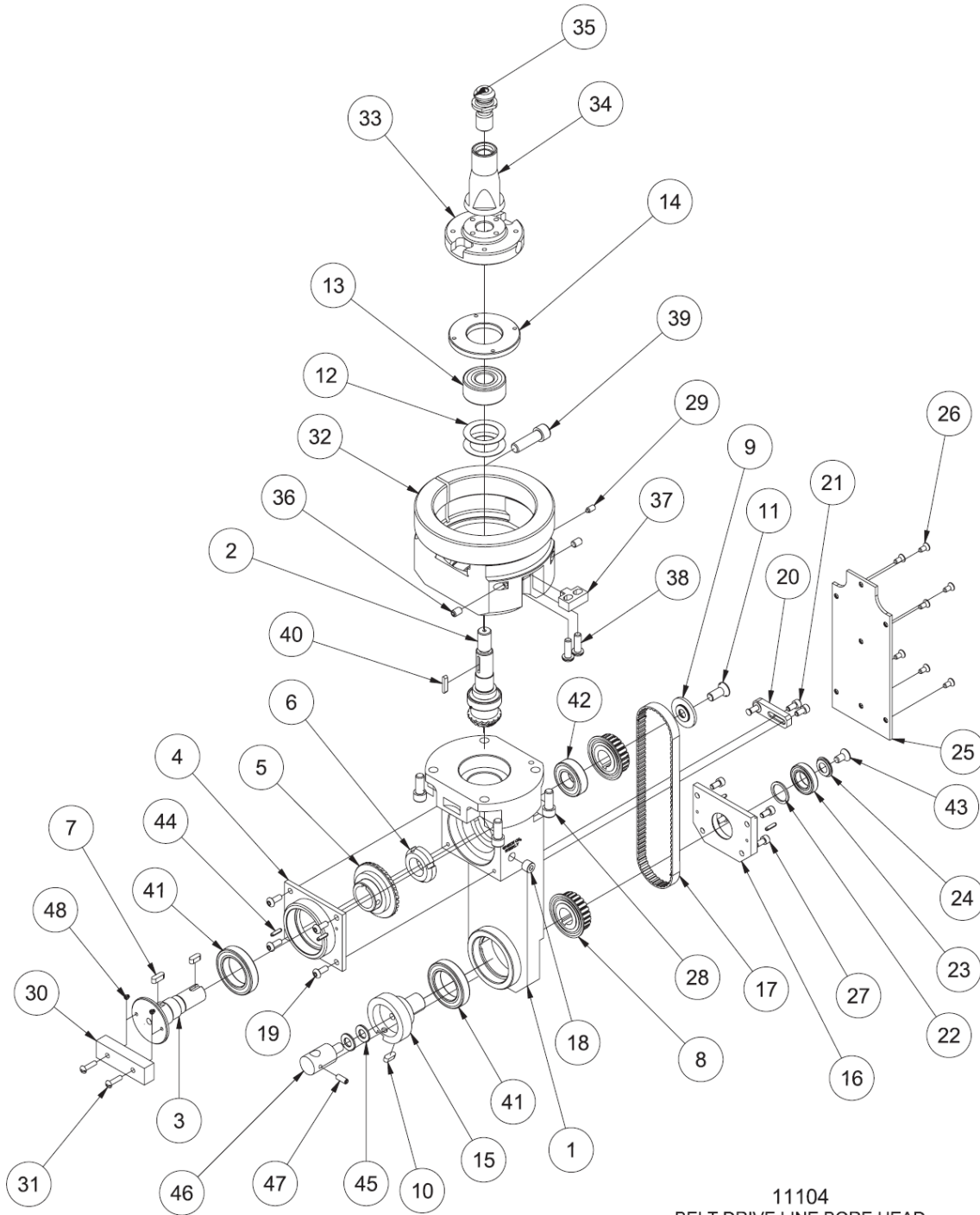

11104
BELT DRIVE LINE BORE HEAD
F70



13003 BELT DRIVE RIGHT ANGLE DRIVE ASSEMBLY - EM105H			
ITEM	QTY	PART NUMBER	DESCRIPTION
1	1	650-2-38B	HOUSING, RIGHT ANGLE DRIVE, BELT DRIVE – F65
2	1	650-2-37X	PINION AND SHAFT ASS'Y, BELT DRIVE R.A.D.
3	1	650-2-37D	SHAFT, HORIZONTAL UPPER – BELT DRIVE R.A.D.
4	1	650-2-37C	BEARING COVER, BELT DRIVE R.A.D. – F65
5	1	6766W	RING GEAR REWORK – F60 SMALL 90 DEG R.A.D.
6	1	6705B	BEARING LOCK NUT
7	1	650-2-18M	KEY, HORIZONTAL SHAFT – R.A.D.
8	2	650-2-37G	PULLEY (REWORK), BELT DRIVE R.A.D. – F60
9	1	650-2-37E	ENDCAP, UPPER PULLEY RETAINER – BELT DRIVE R.A.D.
10	2	650-2-37U	MICARTA KEY, BELT DRIVE R.A.D.
11	1	6774K	SOCKET FLAT HEAD SCREW 5/16-24 X 3/4"
12	2	6007A	BELLVILLE SPRING, BS203
13	1	502-9-32	BALL BEARING
14	1	6772A	NUT, BEARING, R.A.D.
15	1	650-2-42B	HORIZONTAL SHAFT
16	1	650-2-37L	LOWER BEARING RETAINER – BELT DRIVE R.A.D.
17	1	650-2-38D	TIMING BELT, BELT DRIVE R.A.D.
18	1	MF-233	PIPE PLUG 1/8" NPT
19	4	MF-88A	SOCKET BUTTON HEAD SCREW #10-24 X 1/2"
20	1	650-2-37P	BELT TENSIONER ASS'Y – BELT DRIVE R.A.D.
21	2	MF-4	SOCKET HEAD CAPSCREW #10-24 X 3/8"
22	1	650-2-37V	SPACER, LOWER PULLEY – BELT DRIVE R.A.D.
23	1	650-2-37J	BALL BEARING
24	1	650-2-37K	END CAP, LOWER – BELT DRIVE R.A.D.
25	1	650-2-38C	BELT COVER – BELT DRIVE R.A.D.
26	7	MF-76	SOCKET FLAT HEAD SCREW #8-32 X 3/8"
27	4	MF-4	SOCKET HEAD CAPSCREW #10-24 X 3/8"
28	4	MF-22	SOCKET HEAD CAPSCREW 5/16-18 X 3/4"
29	1	100-82-2A	SOCKET SET SCREW, BRASS TIPPED, 3/8" LG.
30	1	650-2-38A	RETAINING TOOL – BELT DRIVE R.A.D.
31	2	MF-105	SOCKET BUTTON HEAD SCREW #8-32 X 5/8"
32	1	11103A	HUB, MOUNTING, R.A.D. ASSEMBLY – F70
33	1	11103B	DRIVER, F70 R.A.D.
34	1	11103C	MOUNT, RETENTION KNOB, R.A.D. – F70
35	1	650-2-44L	CAT 40 RETENTION KNOB
36	2	MF-59	SOCKET SET SCREW, FLAT POINT, 1/4-20 X 3/8"
37	1	6750K	KEY, LOCATING, R.A.D.
38	2	MF-92	SOCKET BUTTON HEAD SCREW 1/4-20 X 3/4"
39	1	MF-32	SOCKET HEAD CAPSCREW 3/8-16 X 1 1/4"
40	1	6753V	KEY (MICARTA), PINION – R.A.D.
41	2	502-9-72C	BALL BEARING
42	1	6753E	BALL BEARING
43	1	650-2-37Z	SOCKET FLAT HEAD SCREW 1/4-28 X 1/2"
44	4	MF-217	PIN – SLOTTED SPRING
45	2	MF-177	SAE FLAT WASHER 5/16"
46	1	502-9-9S	INDICATOR MOUNT, R.A.D.
47	1	MF-58A	SOCKET SET SCREW, FLAT POINT, #10-24 X 1/2"
48	2	MF-49	SOCKET SET SCREW, #8-32 X 1/8"

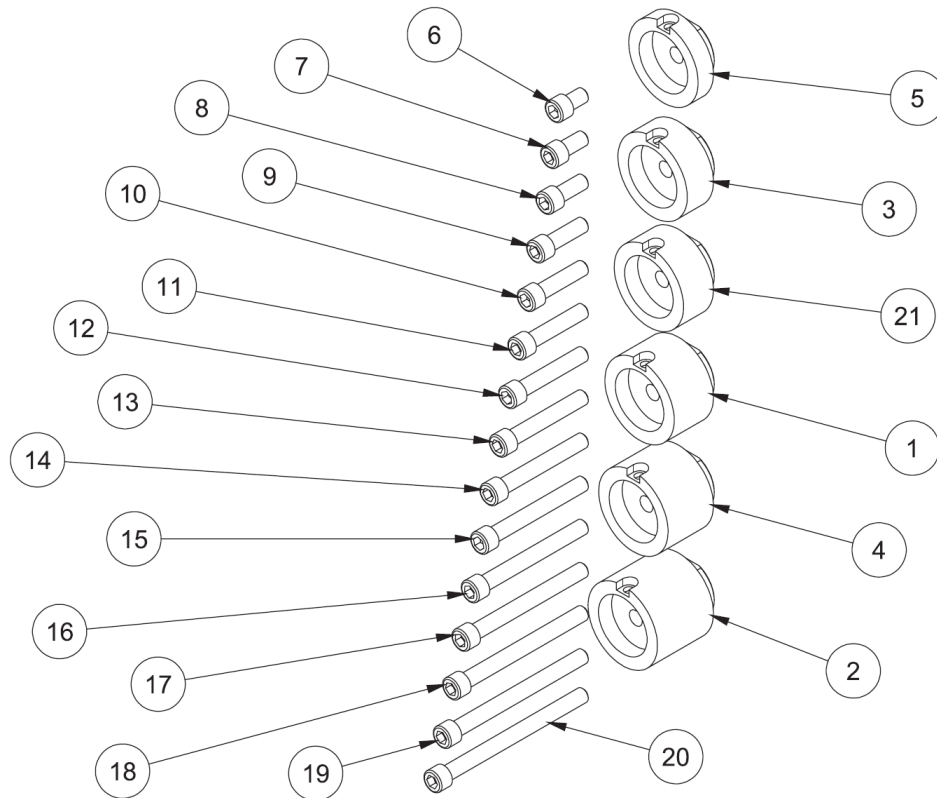

SPACER SET – R.A.D. ASSEMBLY, EM105H			
ITEM	QTY	PART NUMBER	DESCRIPTION
1	1	650-2-43	SPACER (1.05" LG) PRECISION LINE BORE HEAD
2	1	650-2-43A	SPACER (1.50" LG) PRECISION LINE BORE HEAD
3	1	650-2-43B	SPACER (.70" LG) PRECISION LINE BORE HEAD
4	1	650-2-43D	SPACER (1.215" LG) PRECISION LINE BORE HEAD
5	1	650-2-43E	SPACER (.41" LG) PRECISION LINE BORE HEAD
6	1	MF-21A	S.H.C.S 5/16-18 UNC X 1/2
7	1	MF-21	S.H.C.S 5/16-18 UNC X 5/8
8	1	MF-22	S.H.C.S 5/16-18 UNC X 3/4
9	1	MF-23	S.H.C.S 5/16-18 UNC X 1
10	1	MF-24	S.H.C.S 5/16-18 UNC X 1 1/4
11	1	MF-25	S.H.C.S 5/16-18 UNC X 1 1/2
12	1	MF-26	S.H.C.S 5/16-18 UNC X 1 3/4
13	1	MF-27	S.H.C.S 5/16-18 UNC X 2
14	1	MF-27C	S.H.C.S 5/16-18 UNC X 2 1/4
15	1	MF-27A	S.H.C.S 5/16-18 UNC X 2 1/2
16	1	MF-28	S.H.C.S 5/16-18 UNC X 2 3/4
17	1	MF-28E	S.H.C.S 5/16-18 UNC X 3
18	1	MF-28F	S.H.C.S 5/16-18 UNC X 3 1/4
19	1	MF-28A	S.H.C.S 5/16-18 UNC X 3 1/2
20	1	MF-28G	S.H.C.S 5/16-18 UNC X 3 3/4
21	1	650-2-43G	SPACER (.80" LG) PRECISION LINE BORE HEAD

11105 Narrow Right Angle Drive

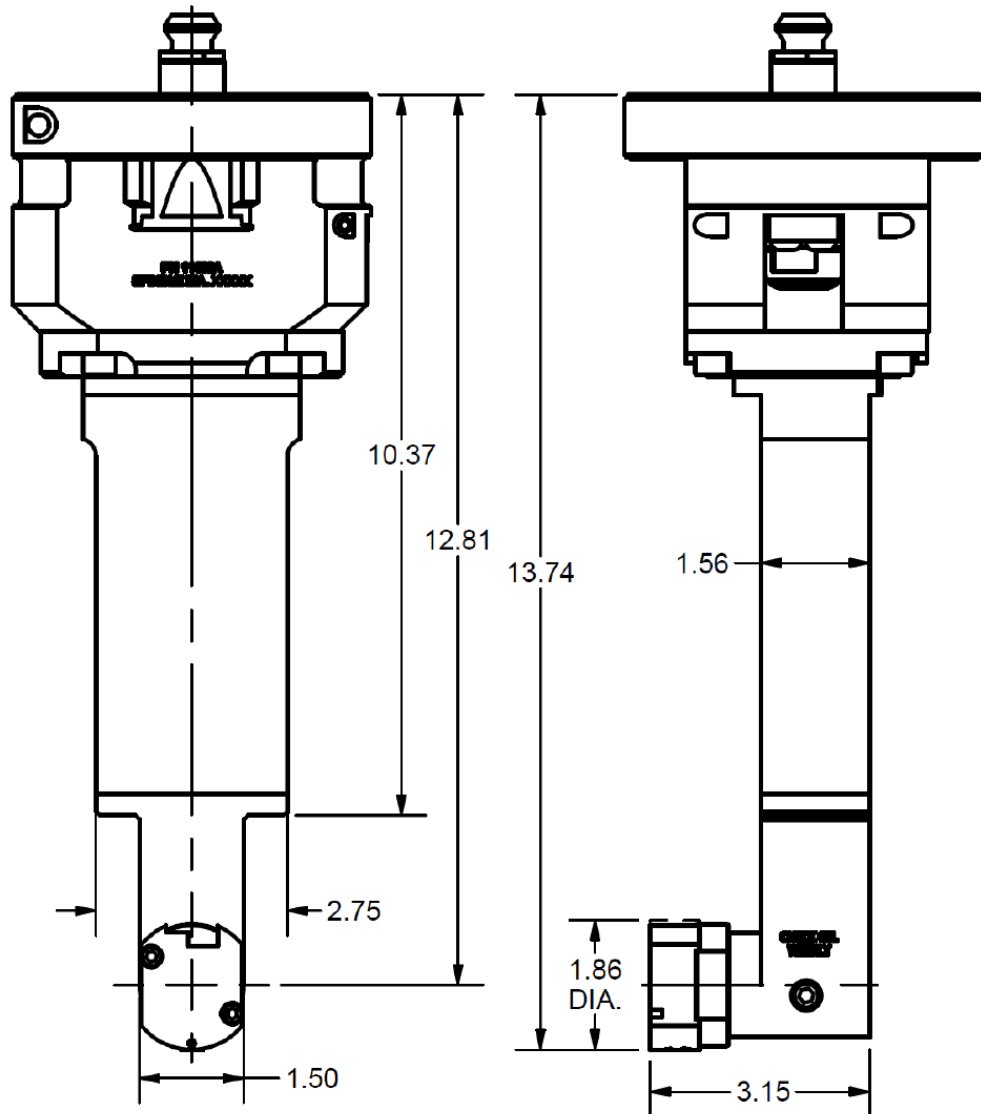
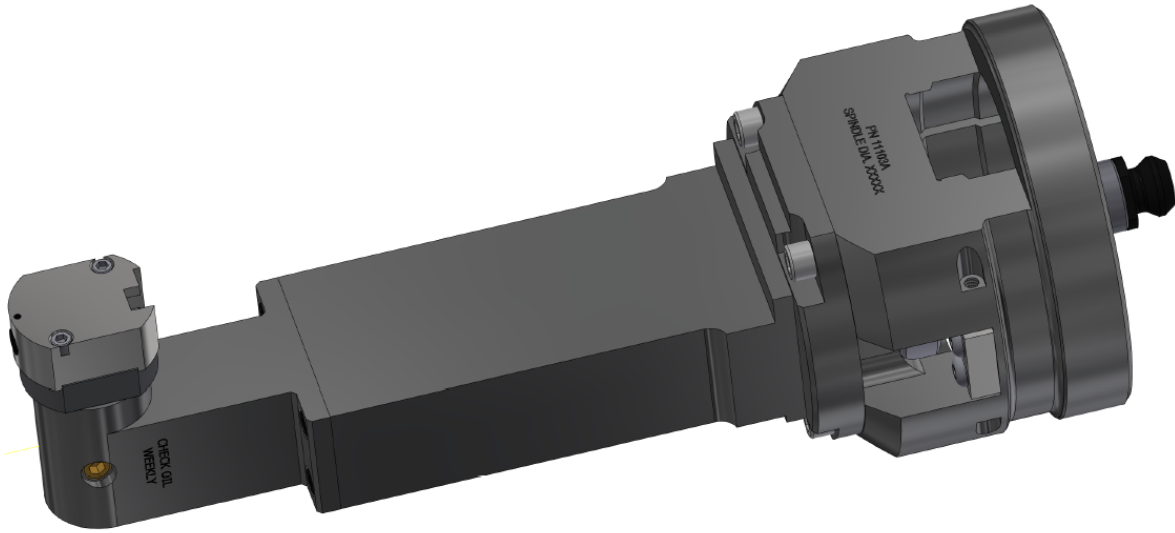

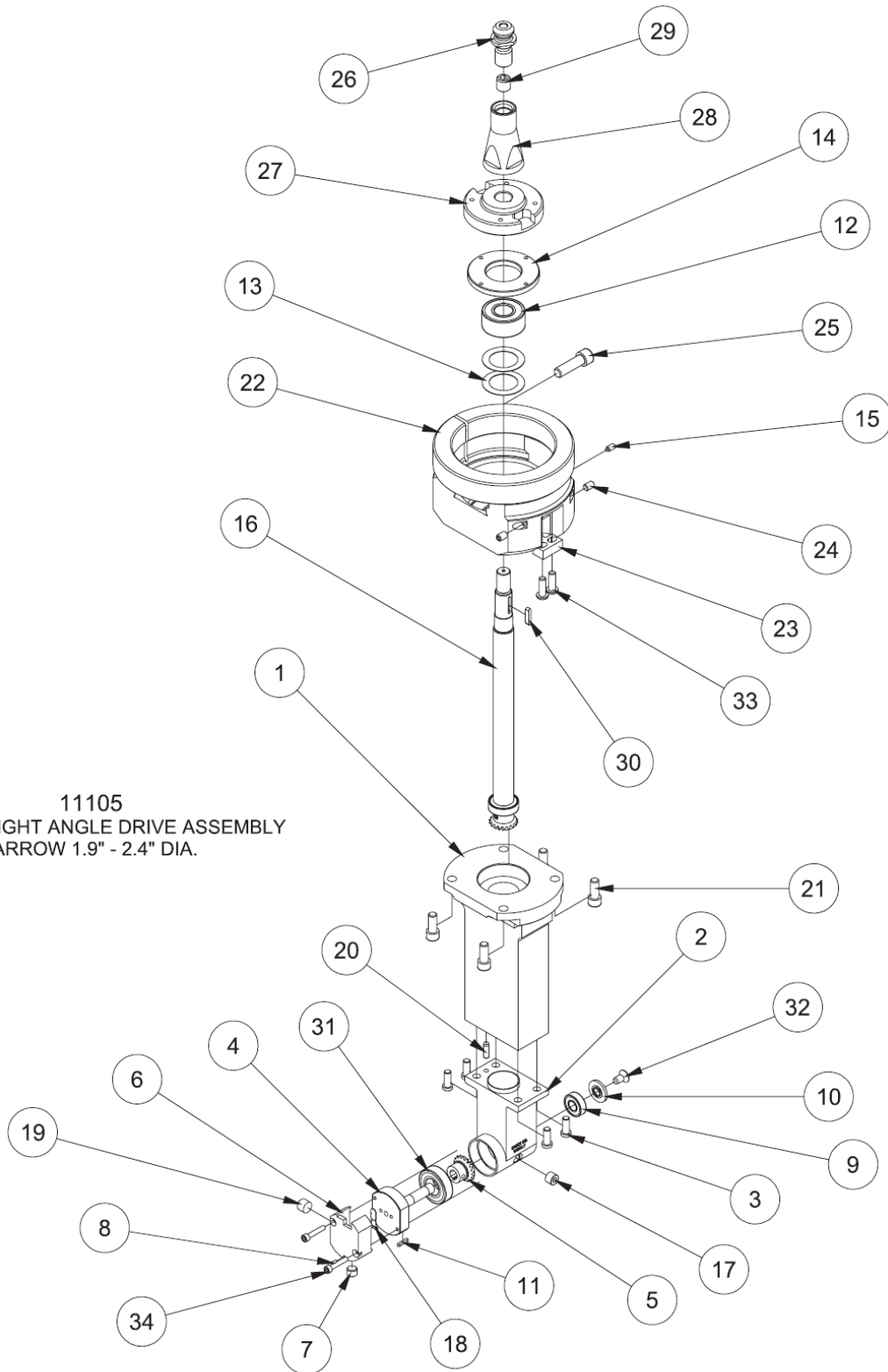

11105
SPECIAL RIGHT ANGLE DRIVE ASSEMBLY
NARROW 1.9" - 2.4" DIA.



11105 NARROW RIGHT ANGLE DRIVE – CAT 40			
ITEM	QTY	PART NUMBER	DESCRIPTION
1	1	650-2-19X	UPPER HOUSING, RIGHT ANGLE DRIVE, NARROW
2	1	650-2-19Y	LOWER HOUSING – F65 R.A.D. (NARROW)
3	4	650-4-18	LOW HEAD CAPSCREW 1/4-20 X 5/8"
4	1	650-2-19J	SHAFT, HORIZONTAL
5	1	650-2-19R	RING GEAR
6	1	650-2-19H	CUTTER HEAD CAP
7	1	502-2-85B	INDEX SCREW
8	1	650-2-6A	SOCKET SET SCREW, BRASS TIPPED, #4-40
9	1	650-2-19L	BEARING
10	1	650-2-19S	COVER, REAR, END CAP
11	1	650-2-19W	KEY
12	1	502-9-32	BALL BEARING
13	2	6007A	BELLVILLE SPRING
14	1	6772A	NUT, BEARING, R.A.D.
15	1	100-82-2A	SOCKET SET SCREW, BRASS TIPPED, #10-24
16	1	650-2-19Z	ASSEMBLY, VERTICAL SHAFT
17	1	MF-233	HEX SOCKET PLUG, 1/8 NPT
18	1	100-1B	TOOL LOCK SPRING
19	1	501-70G	SCREW, TOOL HOLDER LOCK ASSEMBLY
21	4	MF-22	SOCKET HEAD CAPSCREW 5/16-18 X 3/4"
22	1	11103A	HUB, MOUNTING, R.A.D. ASSEMBLY
23	1	6750K	KEY, LOCATING, R.A.D.
24	2	MF-59	SOCKET SET SCREW, FLAT POINT, 1/4-20 X 3/8"
25	1	MF-32	SOCKET HEAD CAPSCREW 3/8-16 X 1 1/4"
26	1	650-2-44L	CAT 40 RETENTION KNOB
27	1	11103B	DRIVER, F70 LINE BORE HEAD
28	1	11103C	MOUNT, RETENTION KNOB, R.A.D.
29	1	11103D	LOCKING SET SCREW, 1/2-13 X 1/2"
30	1	6753V	KEY (MICARTA), PINION – 90 DEG HEAD
31	1	6753E	BALL BEARING
32	1	MF-82	SOCKET FLAT HEAD SCREW 1/4-20 X 1/2"
33	2	MF-92	SOCKET BUTTON HEAD SCREW 1/4-20 X 3/4"
34	2	MF-3E	SOCKET HEAD CAPSCREW #8-32 X 7/8"

Right Angle Drive Accessories

650-2-39B Line Boring Cutterhead Kit, 1.94-4.11" (49.28-104.39mm) Dia

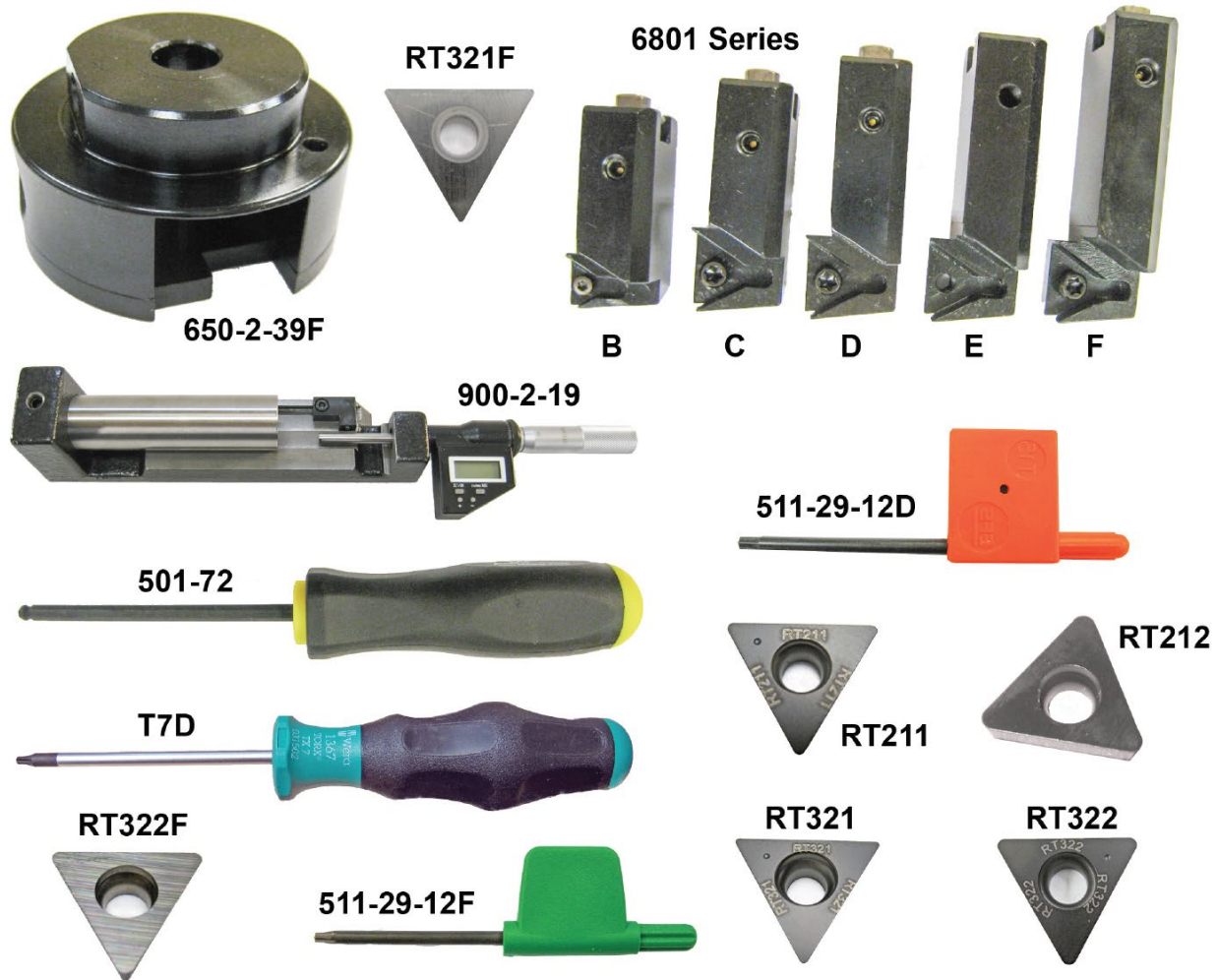

		Tool Diameter Range					
Cutterhead Diameter	Centerline Offset		6801B	6801C	6801D	6801E	6801F
1.9"	-0.650"	Min	1.94"	2.31"	2.70"	3.11"	3.51"
		Max	2.54"	2.91"	3.30"	3.71"	4.11"

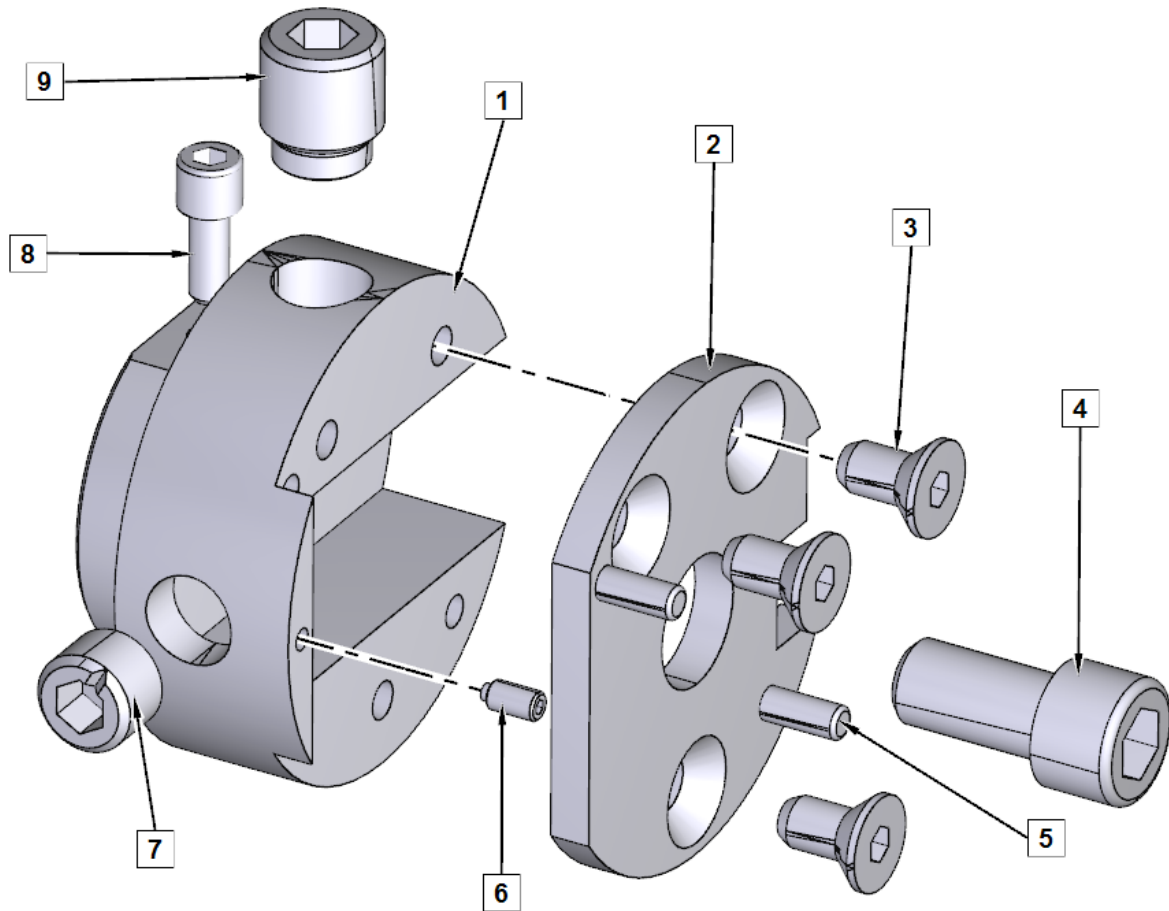

650-2-39F CUTTERHEAD PARTS			
ITEM	QTY	PART NUMBER	DESCRIPTION
1	1	650-2-40A	BODY, 1.9" PRECISION LINE BORE CUTTERHEAD
2	1	650-2-41	CAP, 1.9" DIAMETER PRECISION LINE BORE HEAD
3	3	MF-78	SOCKET FLAT HEAD SCREW #10-24 X 3/8"
4	1	MF-21	SOCKET HEAD CAP SCREW 5/16-18 X 5/8"
5	2	MF-193C	DOWEL PIN, 1/8" X 3/8"
6	1	650-2-6A	SOCKET SET SCREW, BRASS TIPPED, #4-40 X 3/16"
7	1	502-2-85B	SOCKET SET SCREW, INDEX, 3/8-40 FINE THREAD
8	1	MF-4	SOCKET HEAD CAP SCREW #10-24 X 3/8"
9	1	501-70A	SCREW, TOOL HOLDER LOCK ASSY

650-2-39C Line Boring Cutterhead Kit, 2.82-5.52" (71.63-140.21mm) Dia

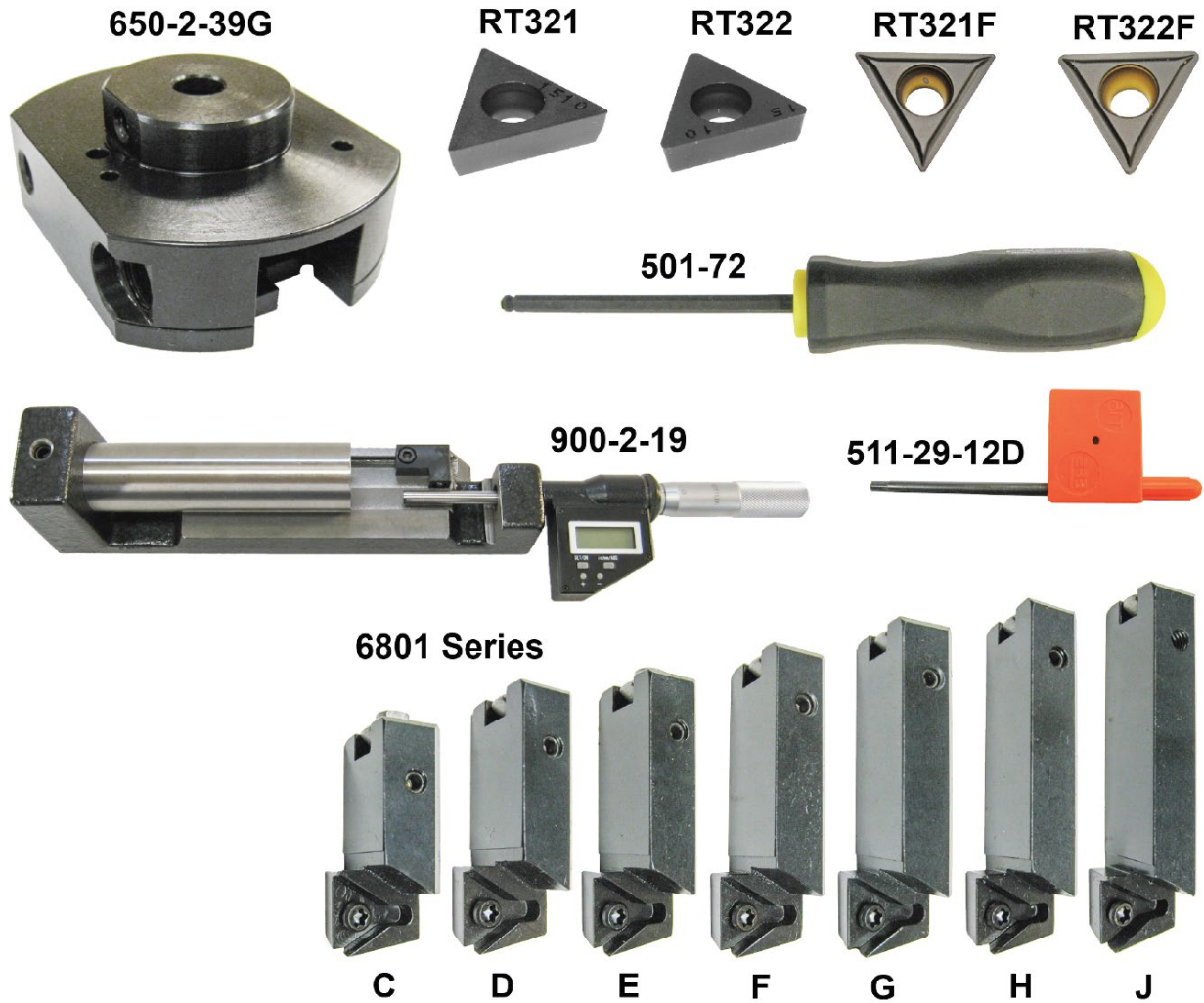

		Tool Diameter Range							
Cutterhead Diameter	Centerline Offset		6801C	6801D	6801E	6801F	6801G	6801H	6801J
2.82"	-0.500"	Min	2.82"	2.99"	3.40"	3.80"	4.20"	4.63"	4.92"
		Max	3.20"	3.59"	4.00"	4.40"	4.80"	5.23"	5.52"

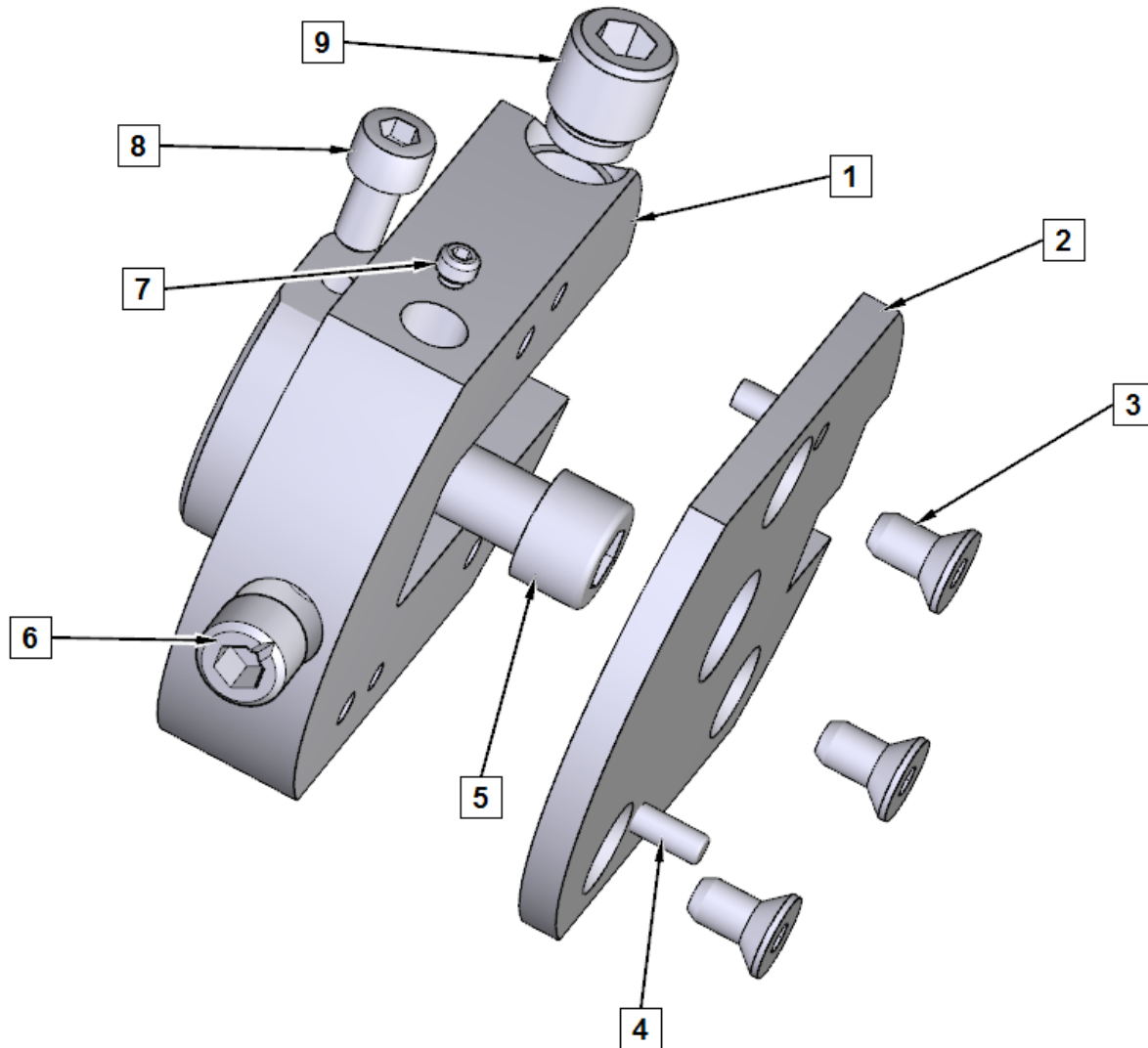

650-2-39G CUTTERHEAD PARTS			
ITEM	QTY	PART NUMBER	DESCRIPTION
1	1	650-2-16E	BODY, 2.9" PRECISION LINE BORE CUTTERHEAD
2	1	650-2-17A	CAP, 2.9" DIAMETER PRECISION LINE BORE HEAD
3	3	MF-78	SOCKET FLAT HEAD SCREW #10-24 X 3/8"
4	2	MF-193C	DOWEL PIN, 1/8" X 3/8"
5	1	MF-21	SOCKET HEAD CAP SCREW 5/16-18 X 5/8"
6	1	502-2-85B	SOCKET SET SCREW, INDEX, 3/8-40 FINE THREAD
7	1	502-12-4D	SOCKET SET SCREW, BRASS TIPPED, #8-32 X 1/8"
8	1	MF-4	SOCKET HEAD CAP SCREW #10-24 X 3/8"
9	1	501-70A	SCREW, TOOL HOLDER LOCK ASSY

<p>501-29-6G Insert, Triangular 0.160 IC, 1/64" (0.397mm) Radius</p> 	<p>501-29-6J Insert, Triangular 0.160 IC, 1/32" (.787mm) Radius</p> 	<p>501-29-6H Insert Screw</p> 
---	--	--

6855Q Thrust Facing Tooling Package Components



Special Main line Boring Chamfer Tools

<p>199-90 Tool Holder, 2-3" (50.8-76.2mm)</p> 	<p>199-96 Tool Holder, 3-4" (76.2-101.6mm)</p> 	<p>501-33E Tool Bit, 45° Chamfer</p> 
--	---	---

Insert Holders

Miscellaneous Insert Holders and Tooling

<p>6593S Cartridge, Triangular For Circular Interpolation Counterbore Facing</p> 	<p>6598M Cartridge, Triangular, 13/16" (20mm) length For Counterboring</p> 
<p>6598K Cartridge, Triangular, 1-7/8" (48mm) length For Counterboring</p> 	<p>6598R Cartridge, Triangular Offset 250 (64mm) For Blind Holes</p> 
<p>6513J Tool bit, Brazed Carbide - 037" (940mm) Wide O Ring Grooving</p> 	<p>6513L Tool bit, Brazed Carbide - 039" (991mm) Wide O Ring Grooving</p> 
<p>6513N Tool bit, Brazed Carbide - 060" (1524mm) Wide O Ring Grooving</p> 	<p>6513Q Tool bit, Brazed Carbide - 120" (3048mm) Wide O Ring Grooving</p> 
<p>6513P Tool bit, Brazed Carbide - 085" (2159mm) Wide O Ring Grooving</p> 	<p>6747K Cartridge, Triangular - 5 Degree Chamfer</p> 

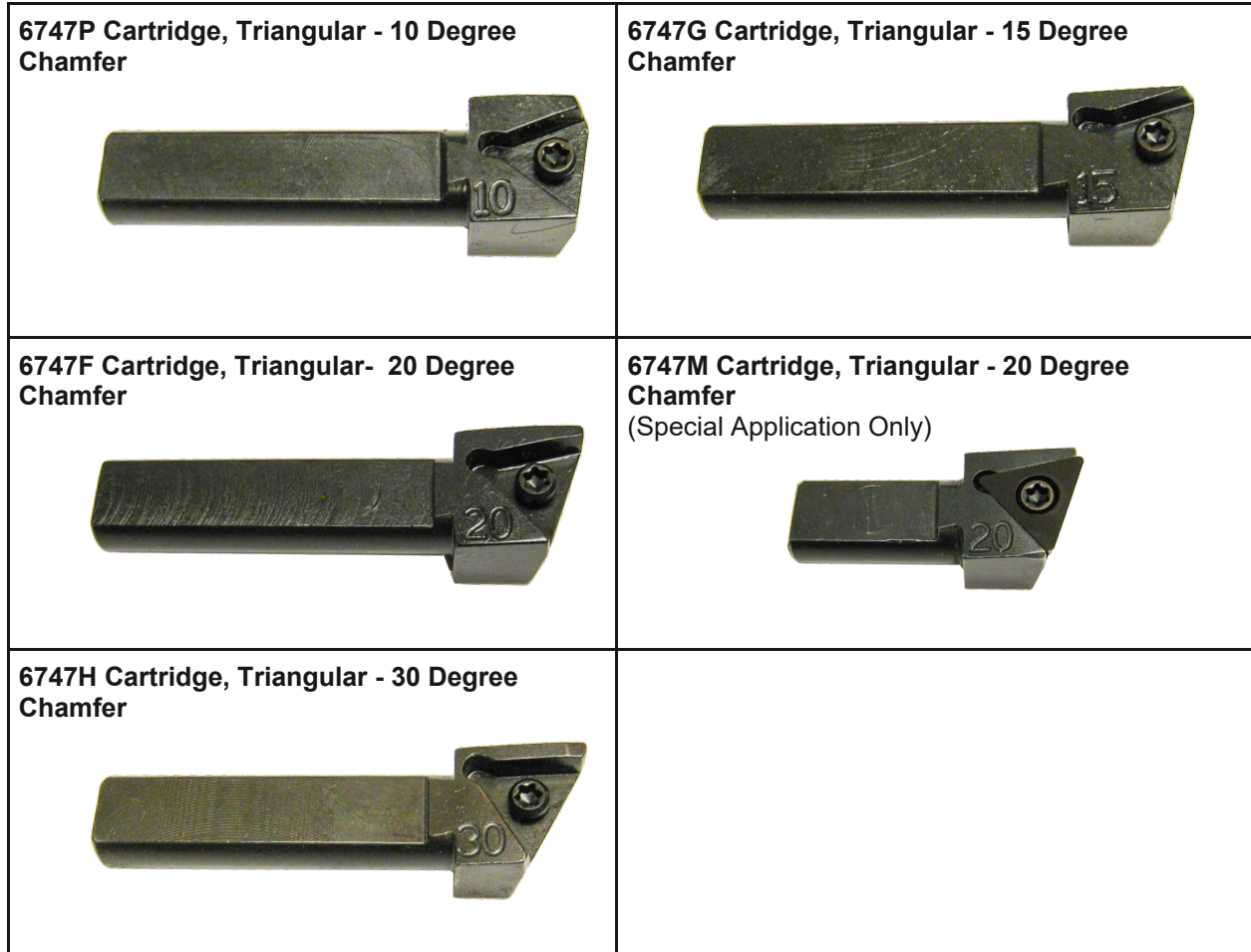

6598 Series Insert Cartridge Parts and Size Chart

6598 Series Tool Bit when used with 6520 Holders		
Tool Bit	Tool Holder	Bore Range
6598M	6520H	3.75" – 4.00"
6598M	6520A	4.00" – 4.50"
6598K	6520B	4.50" – 5.00"
6598K	6520C	5.00" – 5.50"
6598K	6520D	5.50" – 6.00"
6598K	6520E	6.00" – 6.50"
6598K	6520F	6.50" – 7.00"
6598K	6520G	7.00" – 8.00"

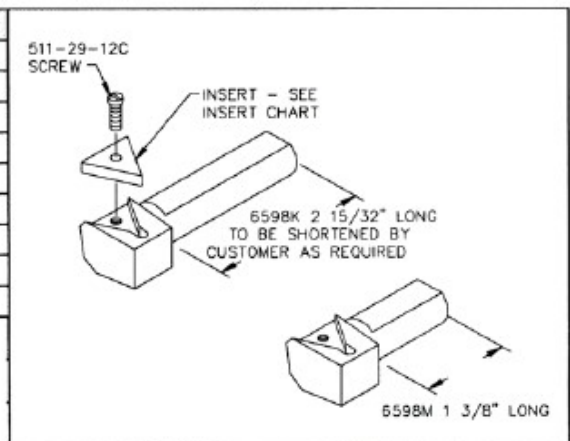

6260L Insert Cartridge Parts

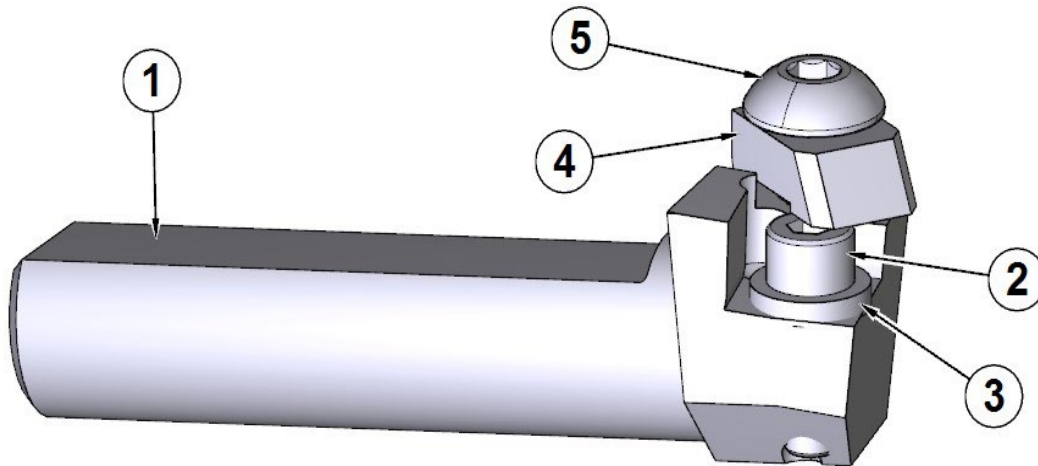

ITEM	QTY	PART NUMBER	DESCRIPTION
1	1	6594G	CARTRIDGE – SQ INSERT, NEG RAKE, 1.88" SHANK
2	1	511-29-12	SCREW
3	1	511-29-12B	WASHER
4	1	6594K	INSERT CLAMP
5	1	MF-89A	SOCKET BUTTON HEAD SCREW #10-32 X 5/8"

6598R Insert Cartridge Parts

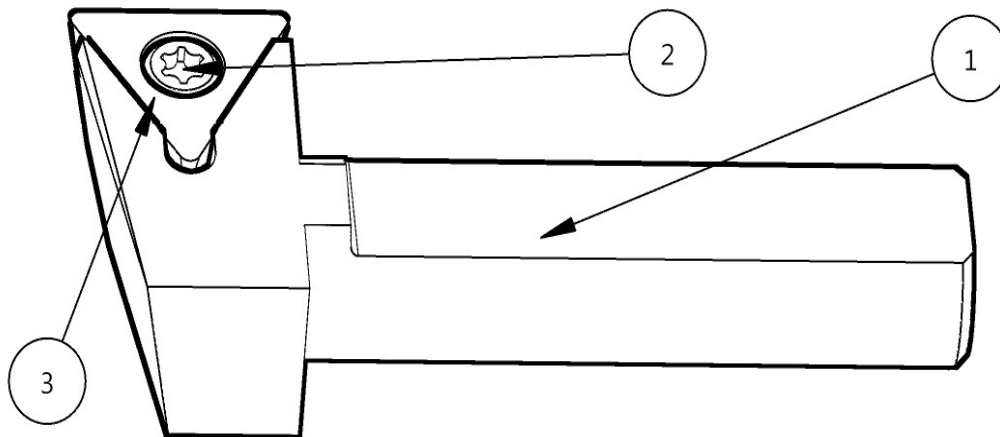

ITEM	QTY	PART NUMBER	DESCRIPTION
1	1	6598Q	TRIANGLE POS. RAKE OFFSET CARTRIDGE
2	1	511-29-12C	TORX SCREW, M4X.7
3	1	RT322	INSERT, TRIANGULAR, 3/8" I.C.

6598M Insert Cartridge Parts

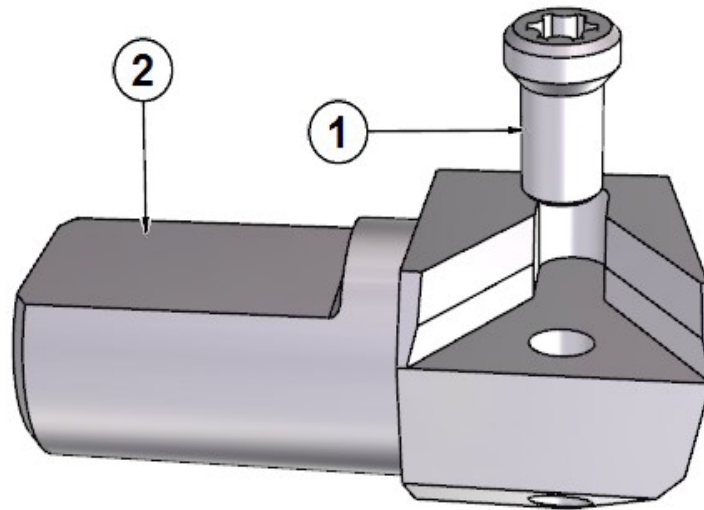

ITEM	QTY	PART NUMBER	DESCRIPTION
1	1	511-29-12C	TORX SCREW, M4X.7
2	1	6598L	CARTRIDGE, INDEXABLE INSERT, 13/16" TRIANGULAR

6260W Insert Cartridge Parts

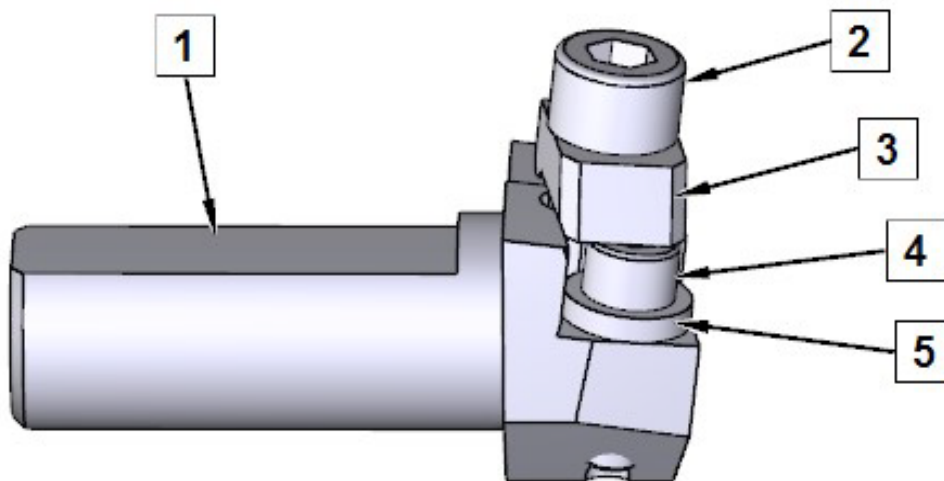

ITEM	QTY	PART NUMBER	DESCRIPTION
1	1	6594J	CARTRIDGE, OFFSET, 3/8" SQ INSERT, NEG RAKE
2	1	MF-9	SOCKET HEAD CAPSCREW #10-32 X 5/8"
3	1	6594K	CLAM, TOOL, SQUARE INSERT
4	1	511-29-12	SOCKET HEAD CAPSCREW 6-32 X 7/16"
5	1	511-29-12B	WASHER, PRECISION – HOLDING SCREW

6593 Series Insert Holders

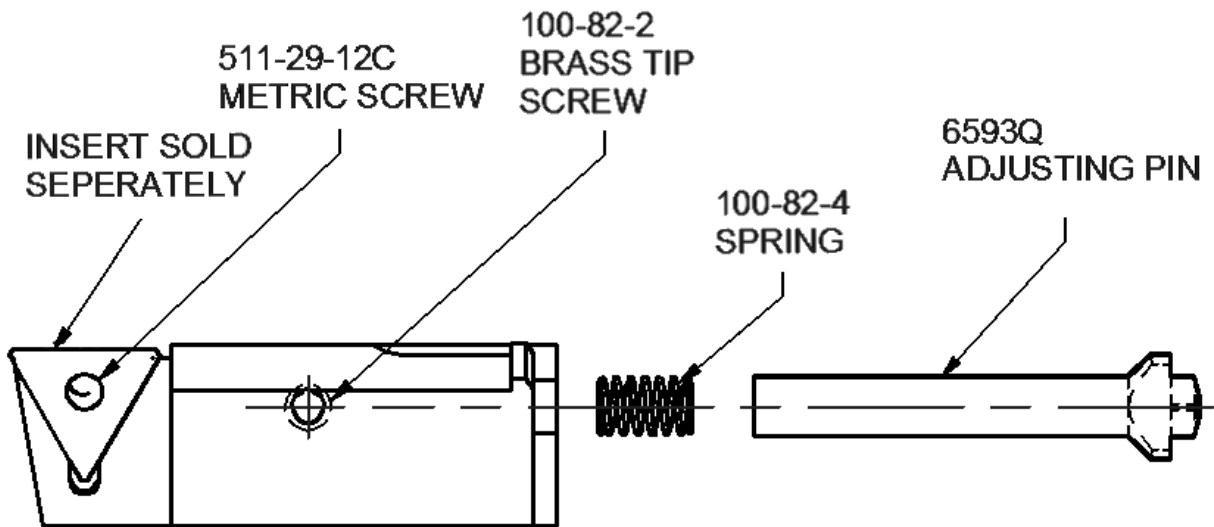

6520 Series Insert Holders

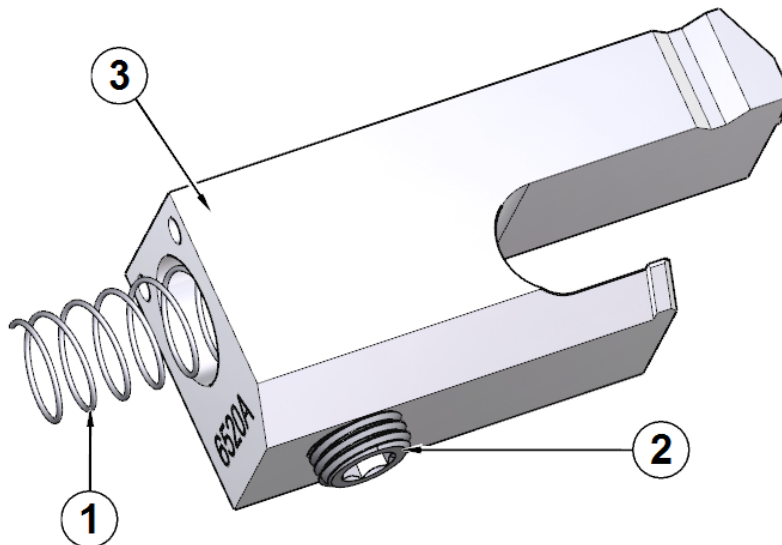

ITEM	QTY	PART NUMBER	DESCRIPTION
1	1	6300B	SPRING, COMPRESSION – TOOLHOLDER (1 7/16")
2	1	502-2-85	SCREW, SET – TOOLHOLDER INDEX
3	1	6520*	TOOL HOLDER

6801 Series Insert Holders

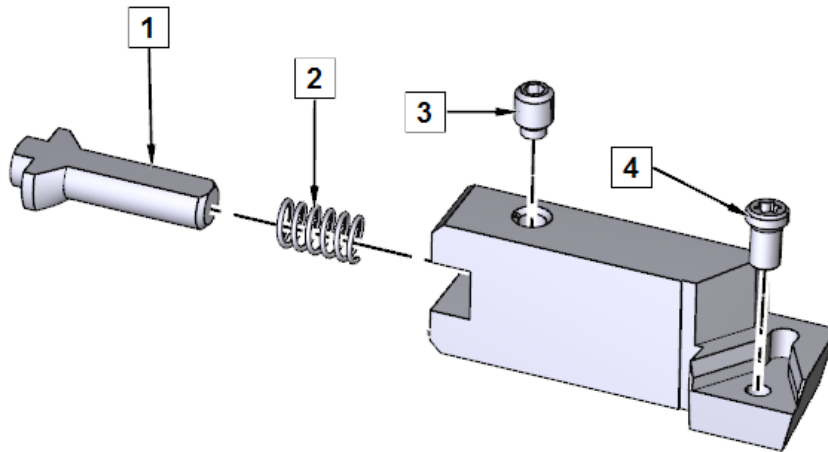

ITEM	QTY	PART NUMBER	DESCRIPTION
1	1	100-82-3B	PIN ADJUSTING LONG INDEXABLE INSERT TOOLHOLDER
2	1	100-82-1	SPRING, ADJUSTING PIN
3	1	100-82-2	SOCKET SET SCREW, BRASS TIP, 3/16" LG
4	1	511-29-12C	SCREW, TORX M4x.7 X .315" LG

6801M Tool Holder Package

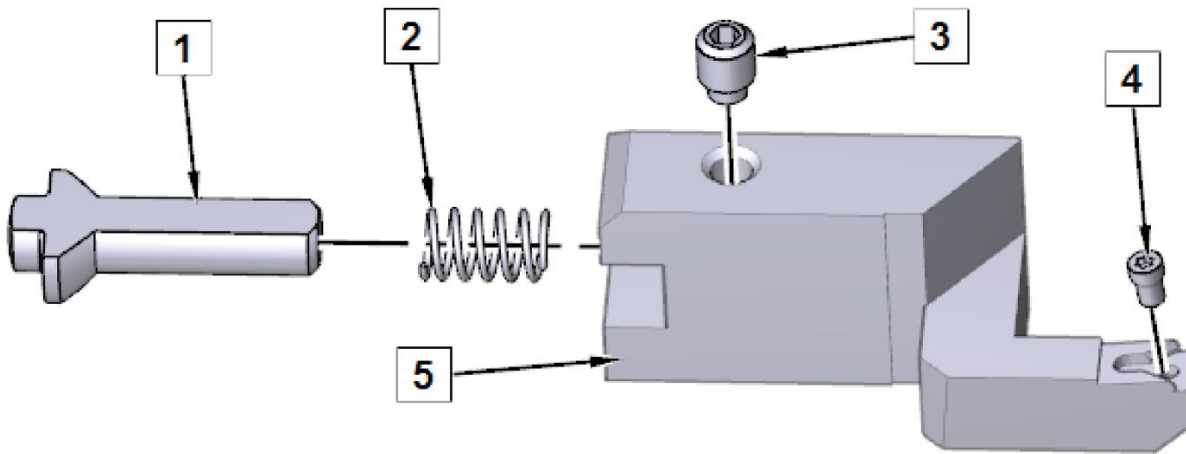

501-29-6G INSERT, TRIANGLE-.160" IC 1/64 RADIUS

501-29-6H SCREW, INSERT THRUST FACING
TOOLBIT-.160" IC TRIANGLE

T7D T7 TORX TIP HOLDING SCREW DRIVER



T8D T8 TORX TIP HOLDING SCREW DRIVER

ITEM	QTY	PART NUMBER	DESCRIPTION
1	1	100-82-3B	PIN ADJUSTING LONG INDEXABLE INSERT TOOLHOLDER
2	1	100-82-1	SPRING, ADJUSTING PIN
3	1	100-82-2	SOCKET SET SCREW, BRASS TIP, 3/16" LG
4	1	501-29-6H	SCREW, INSERT THRUST FACING TOOLBIT
5	1	6800M	CARTRIDGE, INDEXABLE INSERT – THRUST FACING

6801P Tool Holder Package

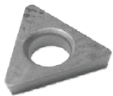
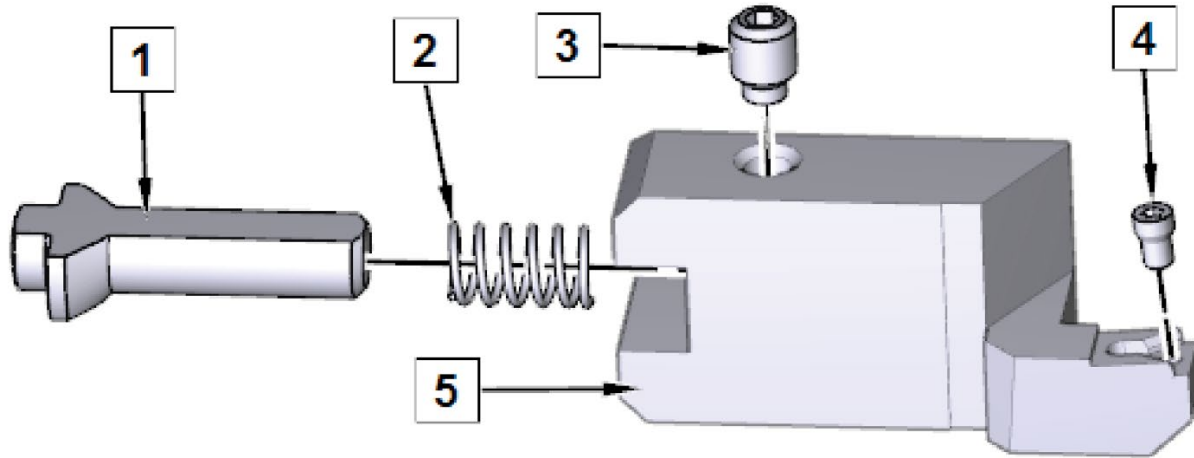

501-29-6G INSERT, TRIANGLE-.160" IC 1/64 RADIUS



501-29-6J INSERT, TRIANGLE-.160" IC 1/32 RADIUS

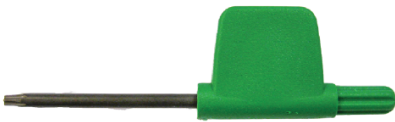

511-29-12F WRENCH, TORX



T8D T8 TORX TIP HOLDING SCREW DRIVER

ITEM	QTY	PART NUMBER	DESCRIPTION
1	1	100-82-3B	PIN ADJUSTING LONG INDEXABLE INSERT TOOLHOLDER
2	1	100-82-1	SPRING, ADJUSTING PIN
3	1	100-82-2	SOCKET SET SCREW, BRASS TIP, 3/16" LG
4	1	501-29-6H	SCREW, INSERT THRUST FACING TOOLBIT
5	1	6800P	CARTRIDGE, INDEXABLE INSERT – THRUST FACING

Micrometers

900-2-19 Tool Setting Micrometer, 1/2" Tooling

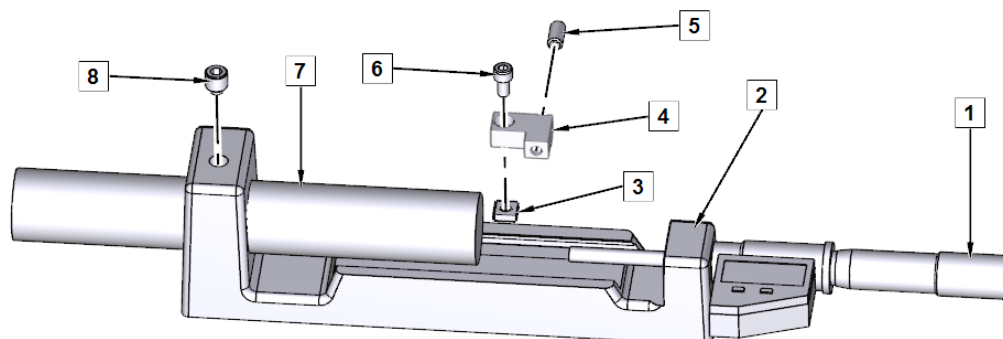

ITEM	QTY	PART NUMBER	DESCRIPTION
1	1	501-34-2R	HEAD, MICROMETER, UNIVERSAL MIC HEAD DIGITAL READING INCH/METRIC
2	1	502-30-10B	FRAME, MICROMETER
3	1	502-30-10J	SQUARE NUT - #10-24 MICROMETER FRAME
4	1	502-30-10M	CLAMP, MICROMETER
5	1	502-30-10K	BALL PLUNGER, 1/4-20 MICROMETER FRAME
6	1	MF-9A	SOCKET HEAD CAPSCREW #10-32 X 3/8"
7	1	502-30-10A	ANVIL, MICROMETER 7/8" DIA X 5 5/8" LG
8	1	502-30-10L	SET SCREW, BRASS TIPPED 3/8-24 X 3/8"

900-2-20 Tool Setting Micrometer, 3/4" Tooling

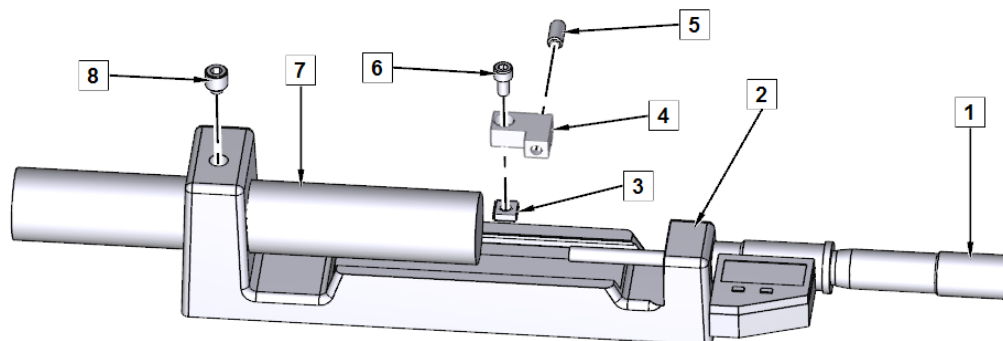

ITEM	QTY	PART NUMBER	DESCRIPTION
1	1	501-34-2R	HEAD, MICROMETER, UNIVERSAL MIC HEAD DIGITAL READING INCH/METRIC
2	1	502-30-10C	FRAME, MICROMETER
3	1	502-30-10J	SQUARE NUT - #10-24 MICROMETER FRAME
4	1	502-30-10M	CLAMP, MICROMETER
5	1	502-30-10K	BALL PLUNGER, 1/4-20 MICROMETER FRAME
6	1	MF-9A	SOCKET HEAD CAPSCREW #10-32 X 3/8"
7	1	502-30-10A	ANVIL, MICROMETER 7/8" DIA X 5 5/8" LG
8	1	502-30-10L	SET SCREW, BRASS TIPPED 3/8-24 X 3/8"

General Purpose Tooling

6648W Caterpillar 3400 Series Tappet Bore Repair Tooling Package

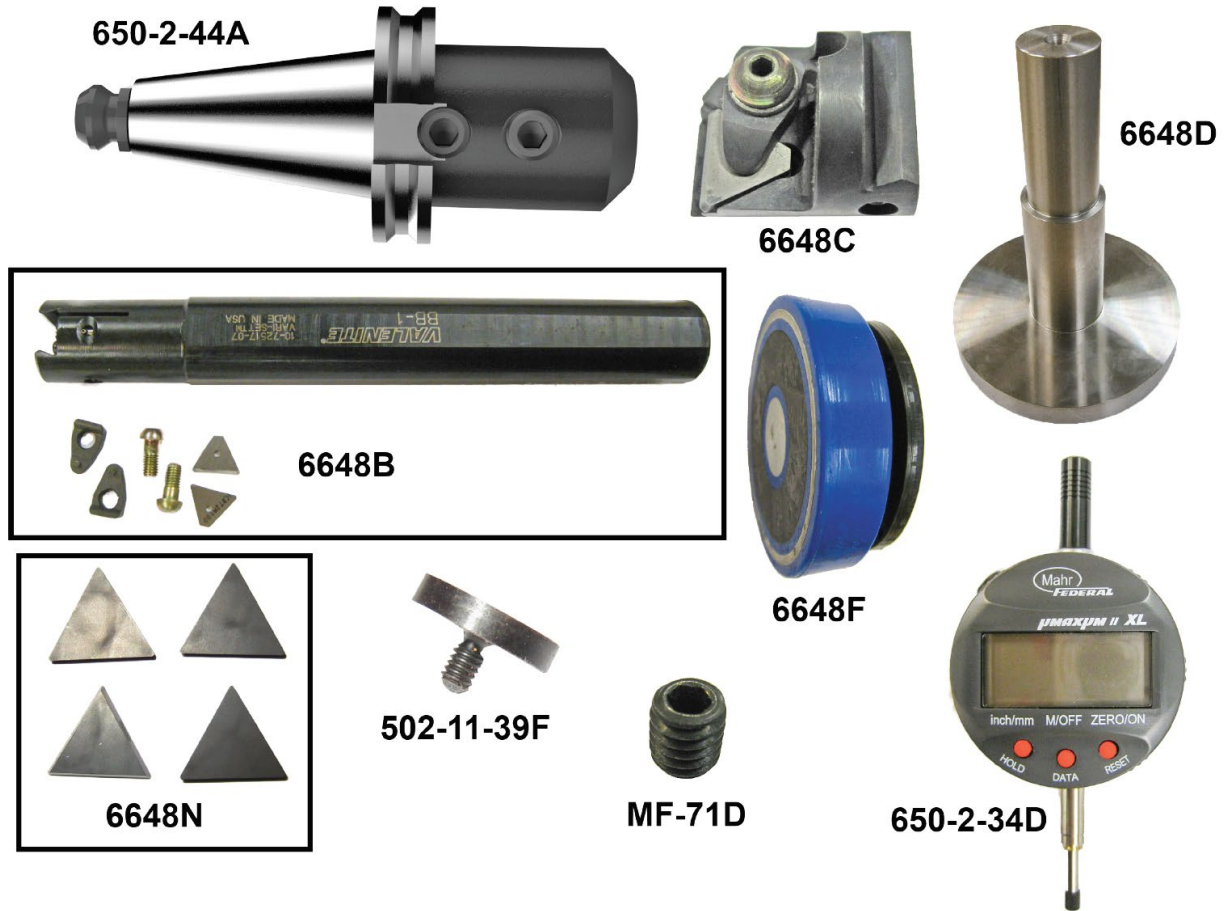

650-2-53 Splayed 4-Bolt Main Cap Machining Tooling Package Components



650-2-44J



650-2-11F



650-2-53B



650-2-11K



650-2-44M



650-2-44N



650-2-53C



650-2-53A



650-2-53D

650-2-44M Drill Chuck Kit

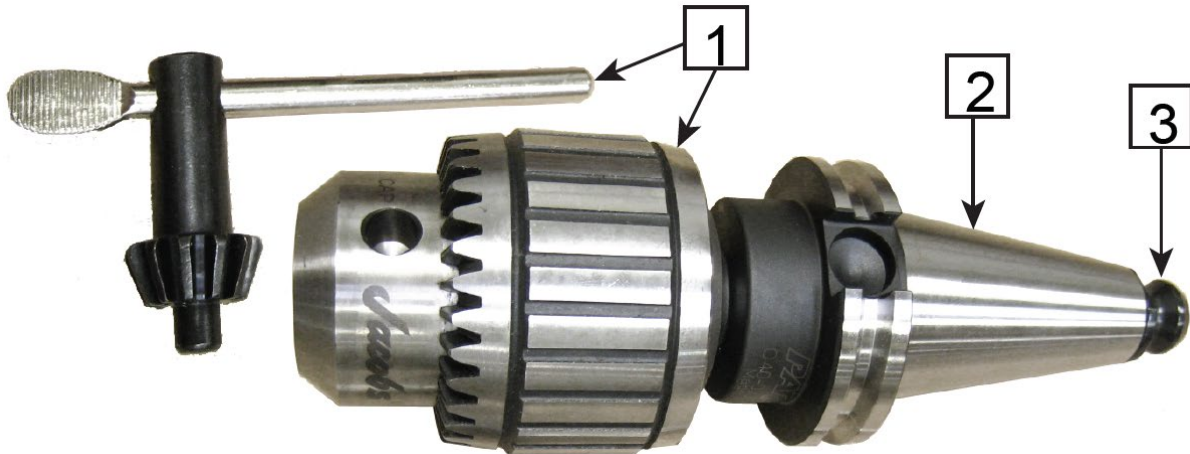

ITEM	QTY	PART NUMBER	DESCRIPTION
1	1	650-2-9B	DRILL CHUCK – 1/8-5/8 WITH KEY
2	1	650-2-44	DRILL CHUCK ADAPTER, CAT 40
3	1	650-2-44L	CAT 40 RETENTION KNOB

650-2-53E Collet Kit



11116 Cross Feed Head Assembly

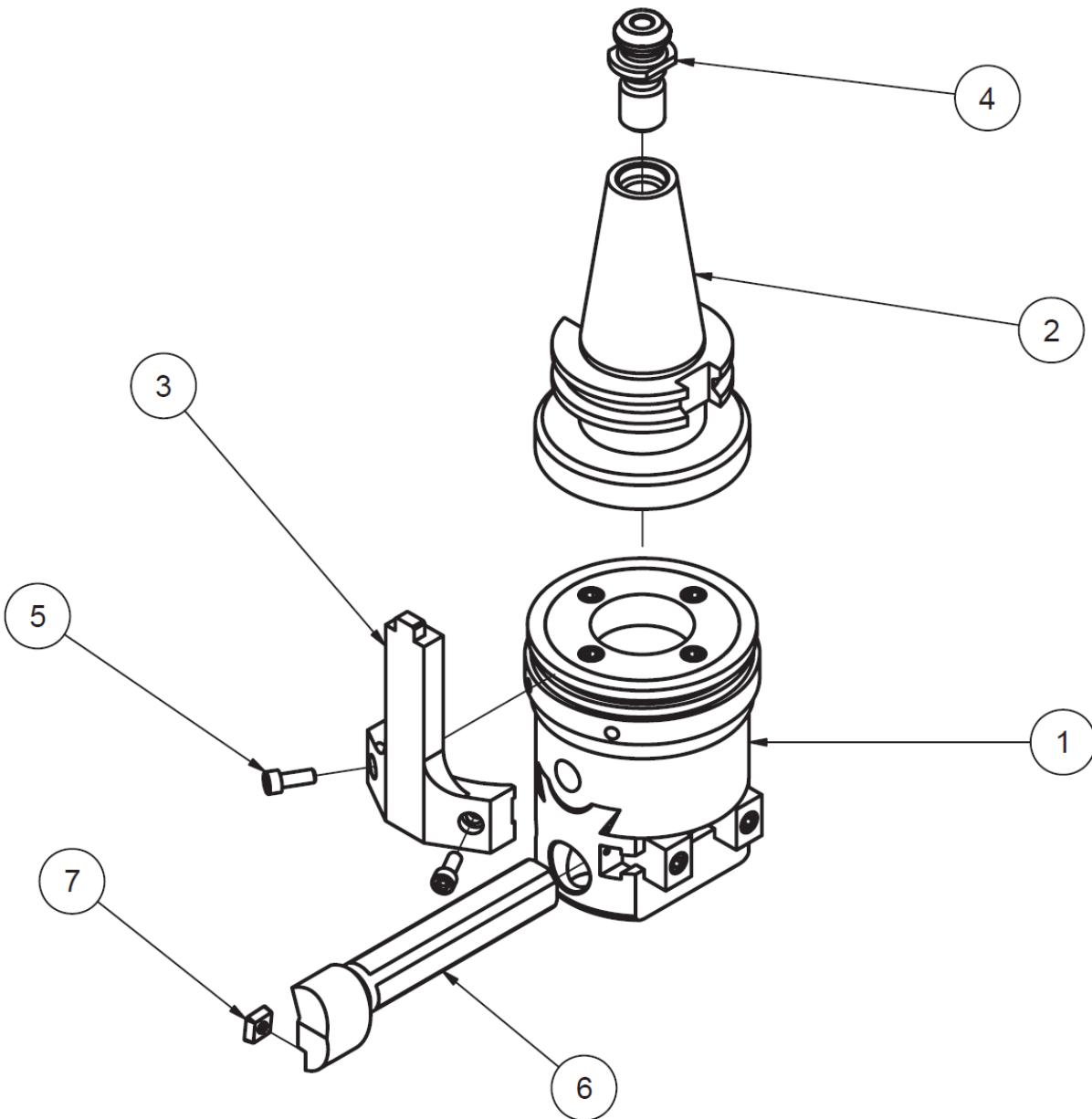

ITEM	QTY	PART NUMBER	DESCRIPTION
1	1	11116A	BODY, CRITERION CROSS FEED HEAD
2	1	650-2-34W	ADAPTER, CROSS FEED HEAD, 40 TAPER
3	1	11116C	DRIVE KEY, CRITERION CROSS FEED HEAD
4	1	650-2-44L	CAT 40 RETENTION KNOB
5	2	-	SOCKET HEAD CAPSCREW #10-32 X 1/2"
6	1	650-2-34U	FACING BAR - PRECISION BORING HEAD ASS'Y
7	1	650-2-34V	INSERT, DIAMOND SHAP, 1/32" R.

650-2-3S Cutterhead Package Components

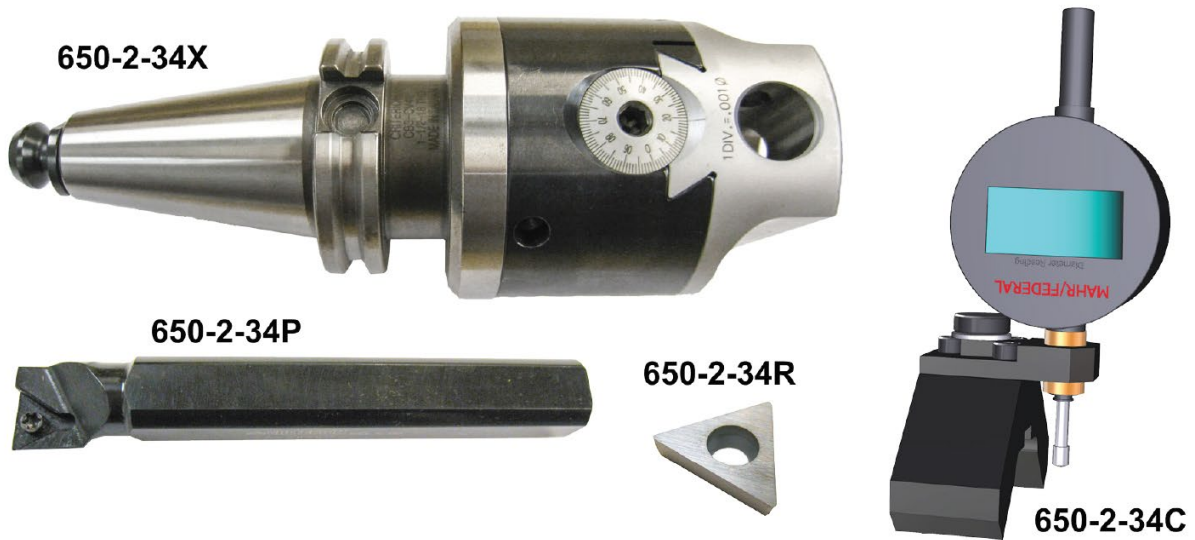

650-2-11K Tap Driver Parts

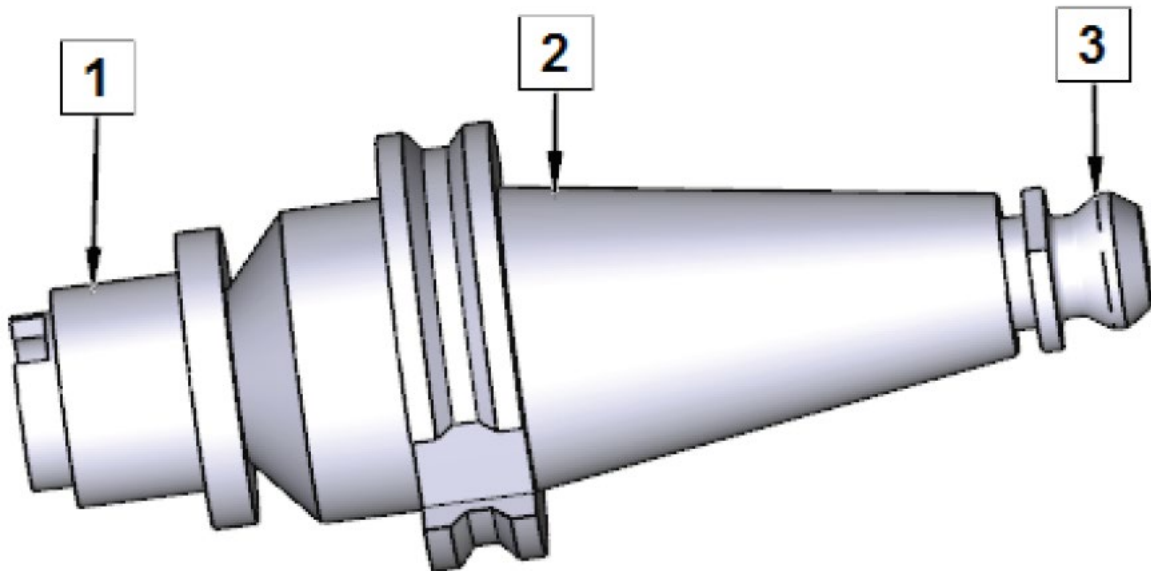

ITEM	QTY	PART NUMBER	DESCRIPTION
1	1	650-2-11B	TAP HOLDER CARTRIDGE – QUICK CHANGE STRAIGHT SHANK ($\frac{3}{4}$ " SHANK)
2	1	650-2-44C	END MILL ADAPTER – $\frac{3}{4}$ " COMPLETE
3	1	650-2-44L	CAT 40 RETENTION KNOB

650-2-44A Endmill Adapter, 1" (25.4mm) Shank Tooling

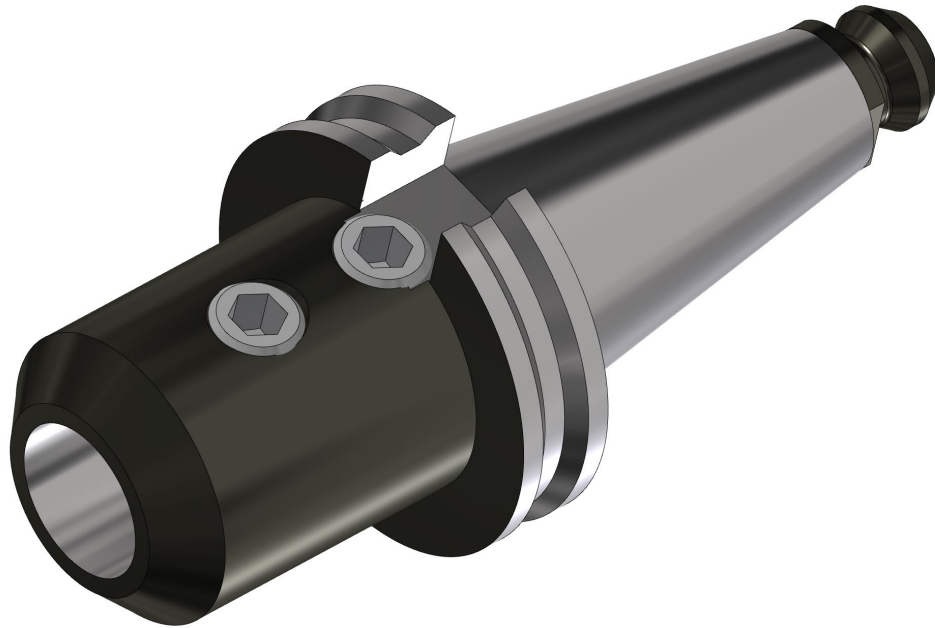

650-2-45H Endmill, 1" (25.4mm) x 8.5" (216mm) OL Roughing



650-2-60B Lifter Bore Tooling Kit



Fixturing

Parallels

11115 Parallels, 2" x 3" (51mm x 76mm)

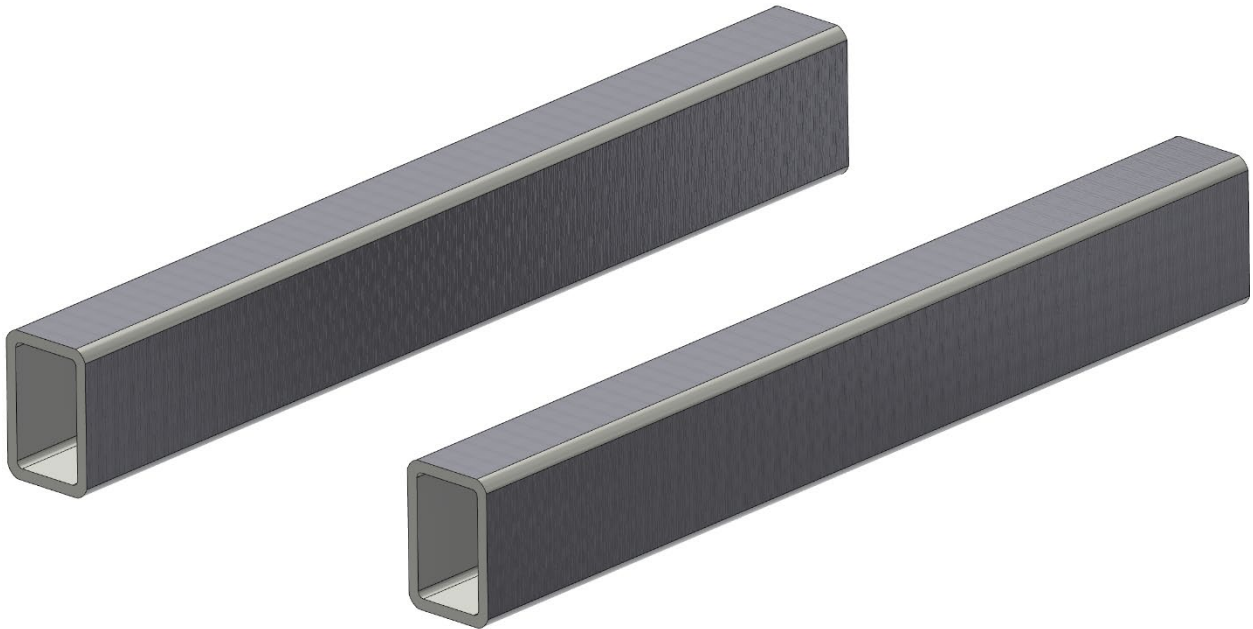

11113L Parallels, 4" (102mm)

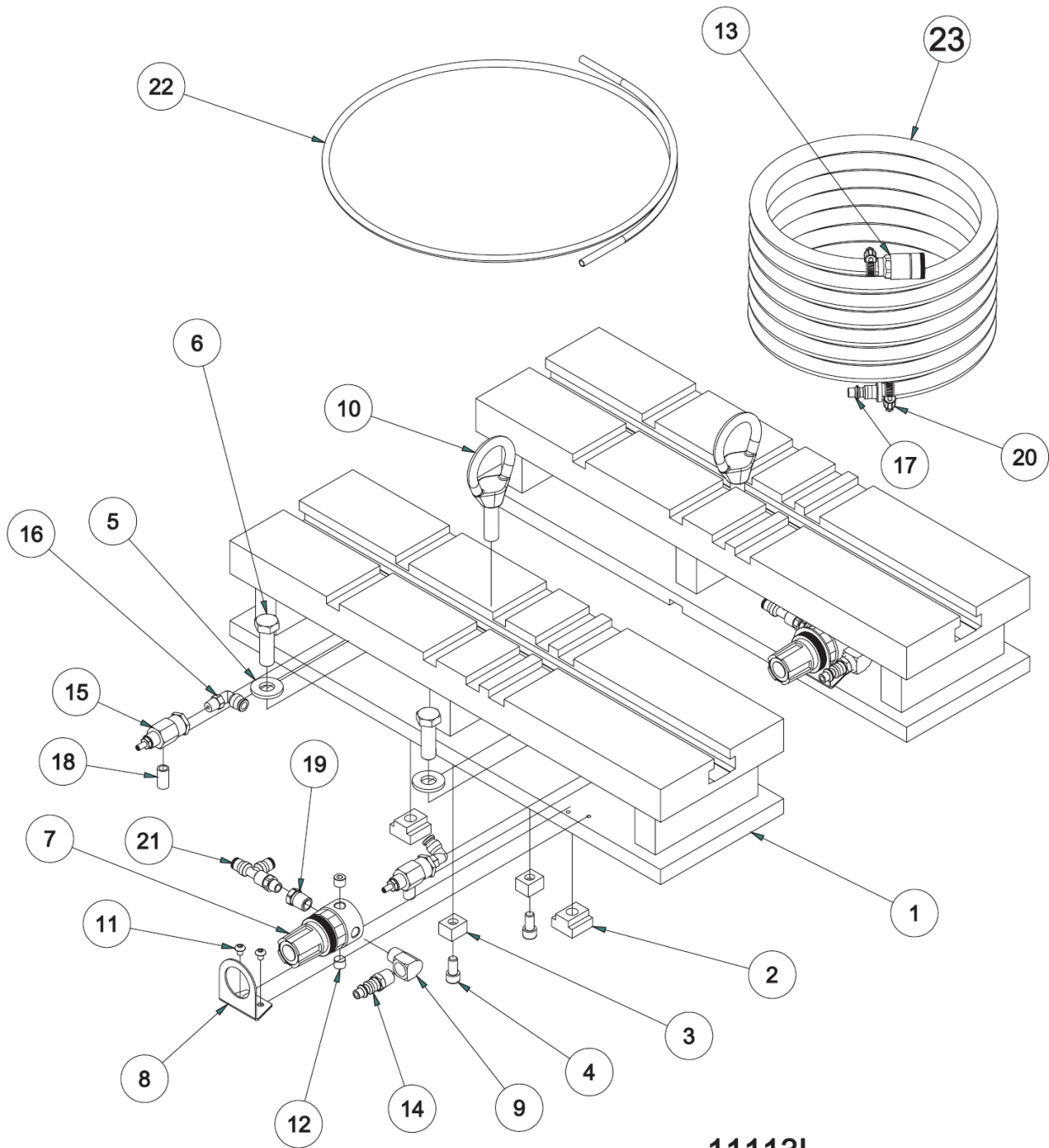

11113L
4" PARALLEL ASSEMBLY



11113L PARALLELS, 4", ASSEMBLY			
ITEM	QTY	PART NUMBER	DESCRIPTION
1	1	11113K	4" PARALLEL, MATCHED SET
3	4	650-3-10	TN-5, T-NUT
2	4	650-3-9	KEY
4	4	MF-21	SOCKET HEAD CAPSCREW 5/16-18 X 5/8"
5	4	100-19A	HARDENED WASHER 17/32"
6	4	MF-150A	HEX HEAD CAPSCREW 1/2-13 X 1 1/2"
7	2	502-27-17	REGULATOR, 0-60 PSI
8	2	502-27-17A	REGULATOR BRACKET
9	2	502-11-17S	STREET ELL, 1/4"
10	2	502-3-13	LIFT EYE
11	4	MF-87	SOCKET BUTTON HEAD SCREW #10-24 X 1/4"
12	4	502-11-17F	HEX SOCKET PLUG, 1/8 NPT
13	1	502-11-16W	QUICK CONNECT AIR FITTING, FEMALE
14	2	502-11-16X	QUICK CONNECT AIR FITTING, MALE
15	4	502-11-35A	FLOW CONTROLLER
16	4	514-4-17E	ELBOW, MALE - 1/4 X 1/8"
17	1	502-11-16Y	CONNECTOR, MALE, AIR 1/4 NPT
18	4	502-11-17J	NIPPLE, CLOSE, 1/8" NPT
19	2	502-11-17H	BUSHING, PIPE, 1/4 X 1/8" NPT
20	2	502-1-97	CLAMP, 1/4" HOSE
21	2	514-4-17X	TEE, RUNNING 1/8 NPT X 1/4 POLY
22	1	502-11-15	4FT HOSE COIL
23	1	502-1-98	15FT, 1/4" AIR HOSE

11112 Parallels, 8" (203mm)

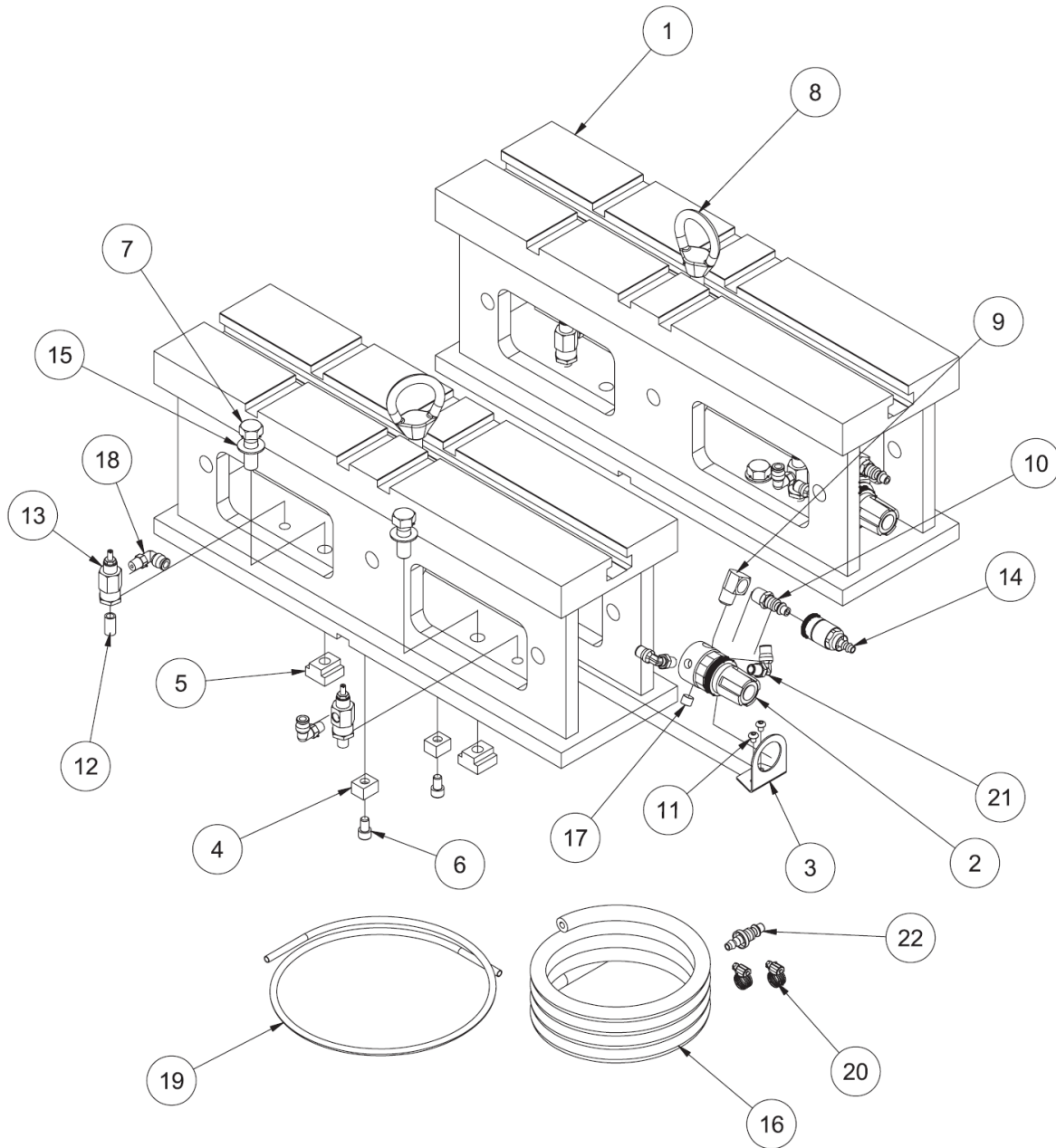

11112
8" SUPPORT PARALLEL ASSEMBLY
F70



11112 PARALLEL, 8", ASSEMBLY			
ITEM	QTY	PART NUMBER	DESCRIPTION
1	2	11112A	SUPPORT PARALLEL 8" (MACHINING)
2	2	502-27-17	REGULATOR, 0-60 PSI
3	2	502-27-17A	REGULATOR BRACKET
4	4	650-3-9	KEY
5	4	650-3-10	TN-5 T-NUT
6	4	MF-21A	SOCKET HEAD CAPSCREW 5/16-18 X 1/2"
7	4	MF-137A	HEX HEAD CAPSCREW 1/2-13 X 1 1/2"
8	2	502-3-13	LIFT EYE
9	2	502-11-17S	STREET ELL, 1/4"
10	2	502-1116X	CONNECTOR, MALE, 1/4 NPT
11	4	MF-87	SOCKET BUTTON HEAD SCREW #10-24 X 1/4"
12	4	502-11-17J	NIPPLE, CLOSE, 1/8" NPT
13	4	502-11-35A	FLOW CONTROL
14	1	502-11-16W	QUICK CONNECT AIR FITTING, FEMALE
15	4	MF-180	FLAT WASHER 1/2"
16	15 FT	502-1-98	AIR HOSE, 1/4"
17	2	MF-234	HEX SOCKET PLUG 1/8" NPT
18	4	514-4-17E	ELBOW, 90 DEG MALE, 1/4" POLY X 1/8" NPT
19	4 FT	502-11-15	TUBING, BLACK POLYFLO, 1/4"
20	2	502-1-97	CLAMP, 1/4" HOSE
21	4	514-4-17V	FITTING, 90 DEG, 1/8 NPT X 1/4 POLY
22	1	502-11-16Y	CONNECTOR, MALE, AIR 1/4 NPT

11114 Parallels, 16" (406mm)

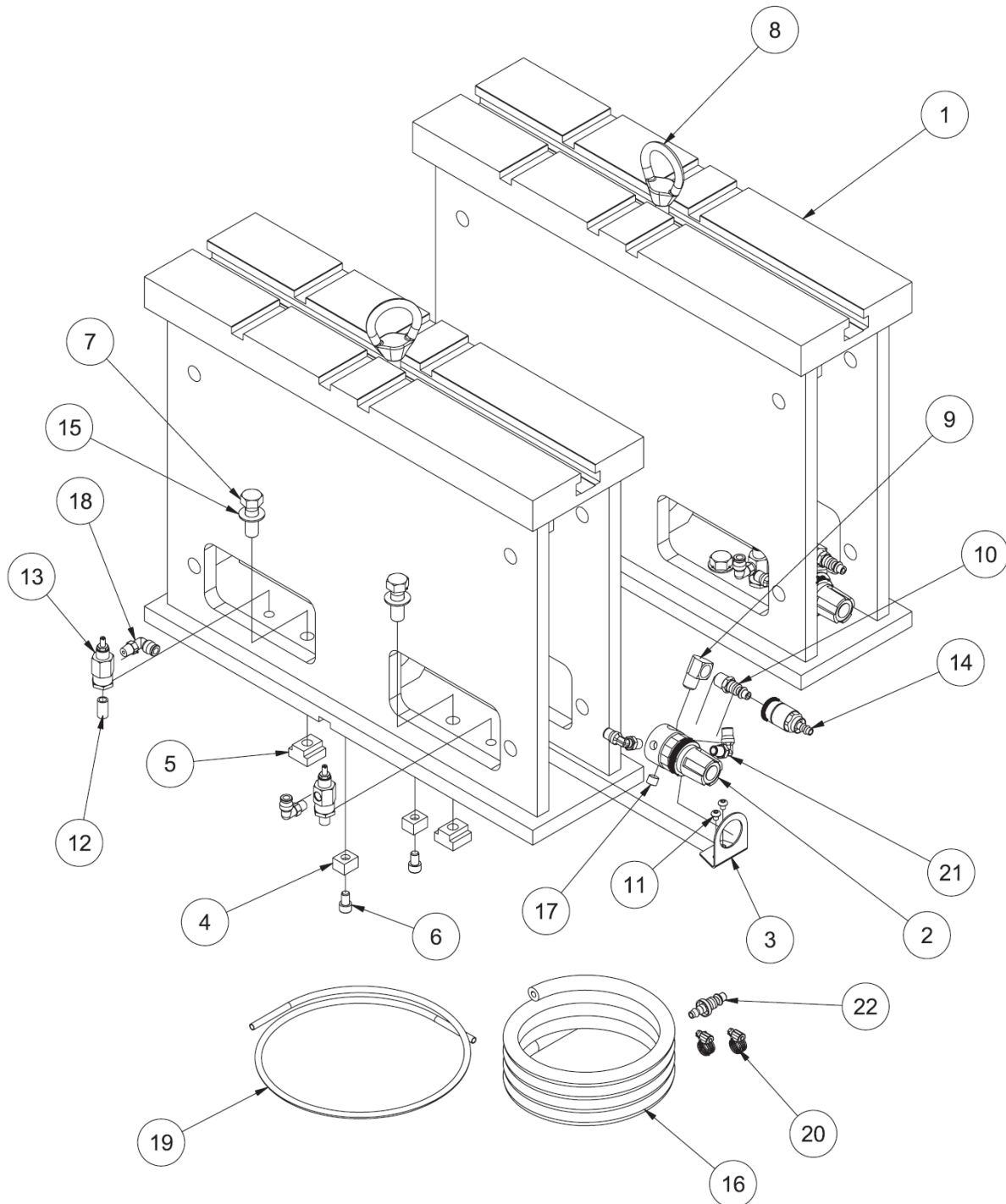

11114
16" SUPPORT PARALLEL ASSEMBLY
F70



11114 PARALLEL, 16", ASSEMBLY			
ITEM	QTY	PART NUMBER	DESCRIPTION
1	2	11114A	SUPPORT PARALLEL 16" (MACHINING)
2	2	502-27-17	REGULATOR, 0-60 PSI
3	2	502-27-17A	REGULATOR BRACKET
4	4	650-3-9	KEY
5	4	650-3-10	TN-5 T-NUT
6	4	MF-21A	SOCKET HEAD CAPSCREW 5/16-18 X 1/2"
7	4	MF-137A	HEX HEAD CAPSCREW 1/2-13 X 1 1/2"
8	2	502-3-13	LIFT EYE
9	2	502-11-17S	STREET ELL, 1/4"
10	2	502-1116X	CONNECTOR, MALE, 1/4 NPT
11	4	MF-87	SOCKET BUTTON HEAD SCREW #10-24 X 1/4"
12	4	502-11-17J	NIPPLE, CLOSE, 1/8" NPT
13	4	502-11-35A	FLOW CONTROL
14	1	502-11-16W	QUICK CONNECT AIR FITTING, FEMALE
15	4	MF-180	FLAT WASHER 1/2"
16	15 FT	502-1-98	AIR HOSE, 1/4"
17	2	MF-234	HEX SOCKET PLUG 1/8" NPT
18	4	514-4-17E	ELBOW, 90 DEG MALE, 1/4" POLY X 1/8" NPT
19	4 FT	502-11-15	TUBING, BLACK POLYFLO, 1/4"
20	2	502-1-97	CLAMP, 1/4" HOSE
21	4	514-4-17V	FITTING, 90 DEG, 1/8" NPT X 1/4" POLY
22	1	502-11-16Y	CONNECTOR, MALE, AIR 1/4 NPT

Block Locating Fixtures

11121 Small- to Mid-Range In-Line and V-Block Fixture Kit, 2"-7" (50.8-177.8mm) Main Bearing Diameter, Tall Version

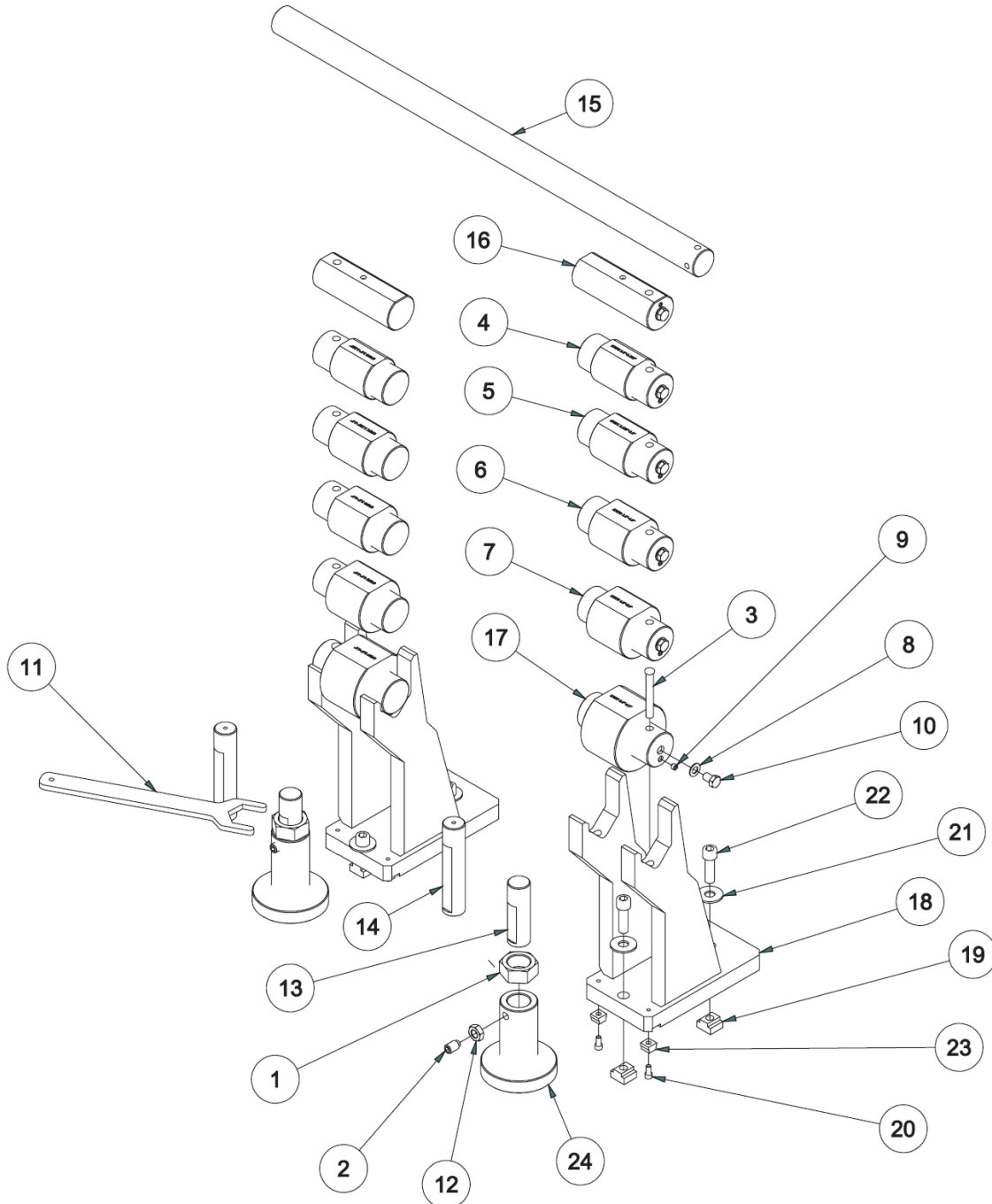

11121
DIESEL FIXTURE ASSEMBLY (TALL VERSION)
INLINE AND MID RANGE V-BLOCK



11121 DIESEL FIXTURE ASS'Y (TALL VERSION)			
ITEM	QTY	PART NUMBER	DESCRIPTION
1	2	6566H	JACKING NUT
2	2	6395B	SOCKET SET SCREW, HALF DOG, 5/8-11 X 1"
3	2	6553H	PIN, LOCATION – DIESEL FIXTURE
4	2	6787B	LOCATOR, MAIN BEARING 3.0-3.225" DIA
5	2	6787C	LOCATOR, MAIN BEARING 3.225-3.5"
6	2	6787D	LOCATOR, MAIN BEARING 3.5-4.0"
7	2	6787E	LOCATOR, MAIN BEARING 4.0-5.0"
8	12	100-19	WASHER
9	12	9788Q	SOCKET SET SCREW, BRASS TIPPED, 3/8-16 X 5/16"
10	12	MF-137E	HEX HEAD CAPSCREW 1/2-13 X 3/4"
11	1	6566K	WRENCH, JACKING NUT – DIESEL FIXTURE
12	2	MF-173	JAM NUT 5/8-11
13	2	7241N	JACKING SCREW 4 3/4"
14	2	6396	JACKING SCREW 7"
15	1	7241E	LOCATOR BAR, ECONOMY HEAD AND BLOCK FIXTURE
16	2	6787M	LOCATOR, MAIN BEARING 2 1/2-3"
17	2	6787F	LOCATOR, MAIN BEARING 5.0-6.0"
18	2	6553F	MACHINING, MAIN BEARING SUPPORT
19	4	502-1-11A	3/4" T-NUT
20	4	MF-21	SOCKET HEAD CAPSCREW 5/16-18 X 5/8"
21	4	MF-181	FLAT WASHER 5/8"
22	4	MF-46D	SOCKET HEAD CAPSCREW 5/8-11 X 2"
23	4	6869A	STEP KEY 3/4" – 5/8"
24	2	6395D	JACK BODY

650-3-56 Line Bore Pivot Table Parts

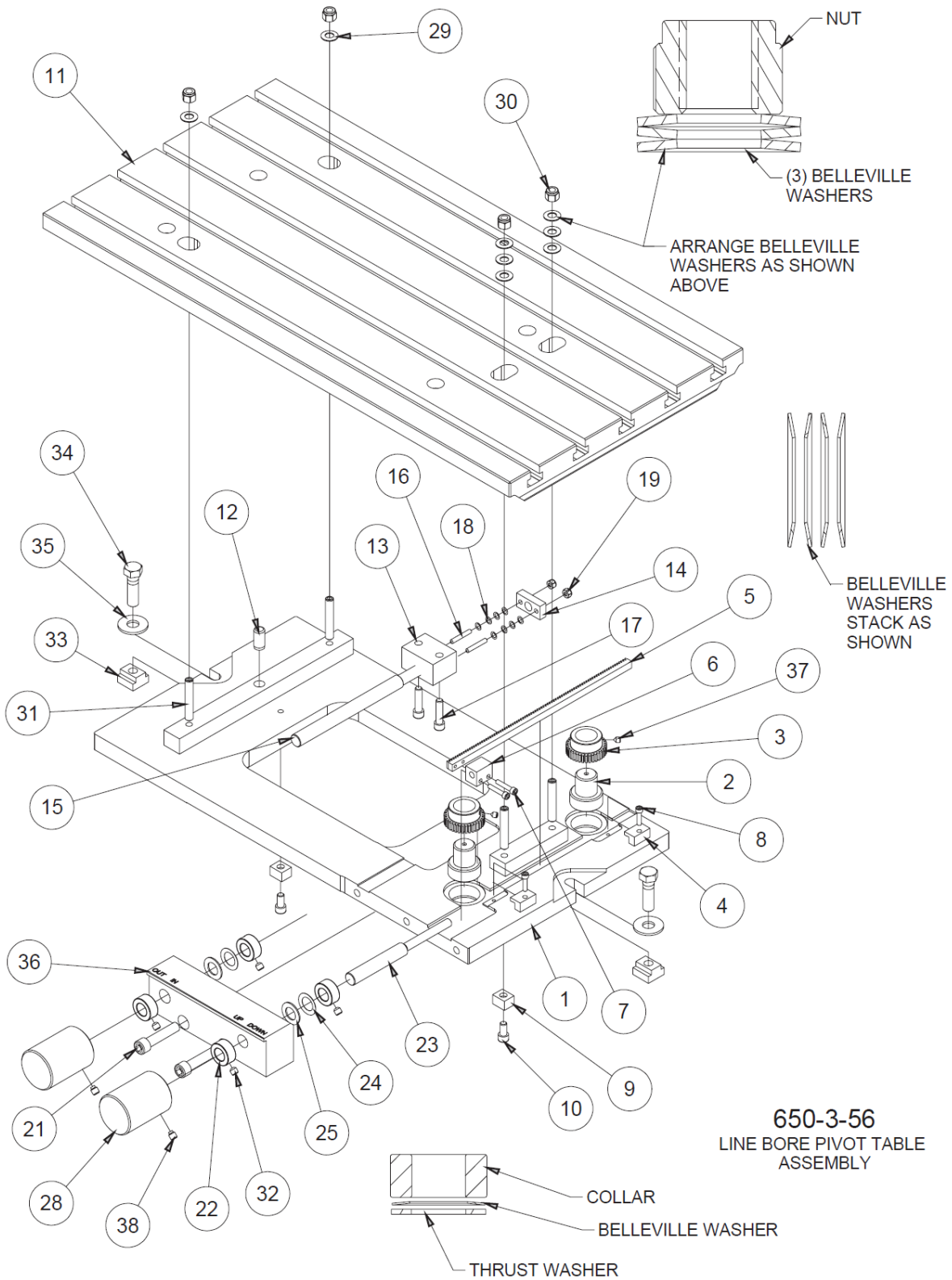

650-3-56
LINE BORE PIVOT TABLE
ASSEMBLY



650-3-56 LINE BORE PIVOT TABLE ASS'Y			
ITEM	QTY	PART NUMBER	DESCRIPTION
1	1	650-3-56C	LINE BORE PIVOT TABLE ASSEMBLY
2	2	650-3-56D	JACK SCREW – PIVOT TABLE
3	2	650-3-56F	GEAR, JACK SCREW – PIVOT TABLE
4	2	650-3-56K	RETAINER, RACK – PIVOT TABLE
5	1	650-3-56V	RACK – PIVOT TABLE
6	1	650-3-56W	THREADED BLOCK – PIVOT TABLE
7	2	MF-6A	SOCKET HEAD CAPSCREW #10-24 X 1"
8	2	MF-6	SOCKET HEAD CAPSCREW #10-24 X ¾"
9	2	650-3-9	KEY
10	2	MF-21	SOCKET HEAD CAPSCREW 5/16-18 X ⅝"
11	1	650-3-56A	TABLE TOP – PIVOT TABLE
12	1	MF-213B	DOWEL PIN ½" X 1"
13	1	650-3-56N	THREADED BLOCK, PIVOT – PIVOT TABLE
14	1	650-3-56R	LOCK PLATE – PIVOT TABLE
15	1	650-2-29D	SHAFT, ROTATE ADJUST – PIVOT TABLE
16	2	MF-57A	SOCKET SET SCREW #10-24 X 1 ¼"
17	2	MF-24	SOCKET HEAD CAPSCREW 5/16-18 X 1 ¼"
18	8	650-3-56Q	BELLEVILLE SPRING
19	2	MF-186B	NYLOCK NUT #10-24
21	2	MF-40A	SOCKET HEAD CAPSCREW 7/16-14 X 2"
22	4	7199E	COLLAR ½"
23	1	650-3-56U	LIFT ADJUST SHAFT
24	2	650-3-56S	BELLEVILLE SPRING, REID BDB-65
25	2	514-7-20	THRUST WASHER
28	2	650-2-29E	HANDLE
29	8	650-2-28P	BELLEVILLE WASHER
30	4	MF-187B	NYLOCK NUT ⅜-16
31	4	MF-75B	SOCKET SET SCREW ⅜-16 X 2 ¼"
32	4	6863	SOCKET SET SCREW, CONE POINT, 5/16-18 X 5/16"
33	2	650-3-10	TN-5 T-NUT
34	2	MF-137F	HEX HEAD CAPSCREW ½-13 X 1 ¾"
35	2	MF-180	FLAT WASHER ½"
36	1	650-3-56L	CONTROL BLOCK – PIVOT TABLE
37	2	MF-59B	SOCKET SET SCREW, CONE POINT, ¼-20 X 5/16"
38	2	504-29-36	SOCKET SET SCREW, HALF DOG, 5/16-18 X ⅝"

11113 Adjustable Line Boring Parallel Kit

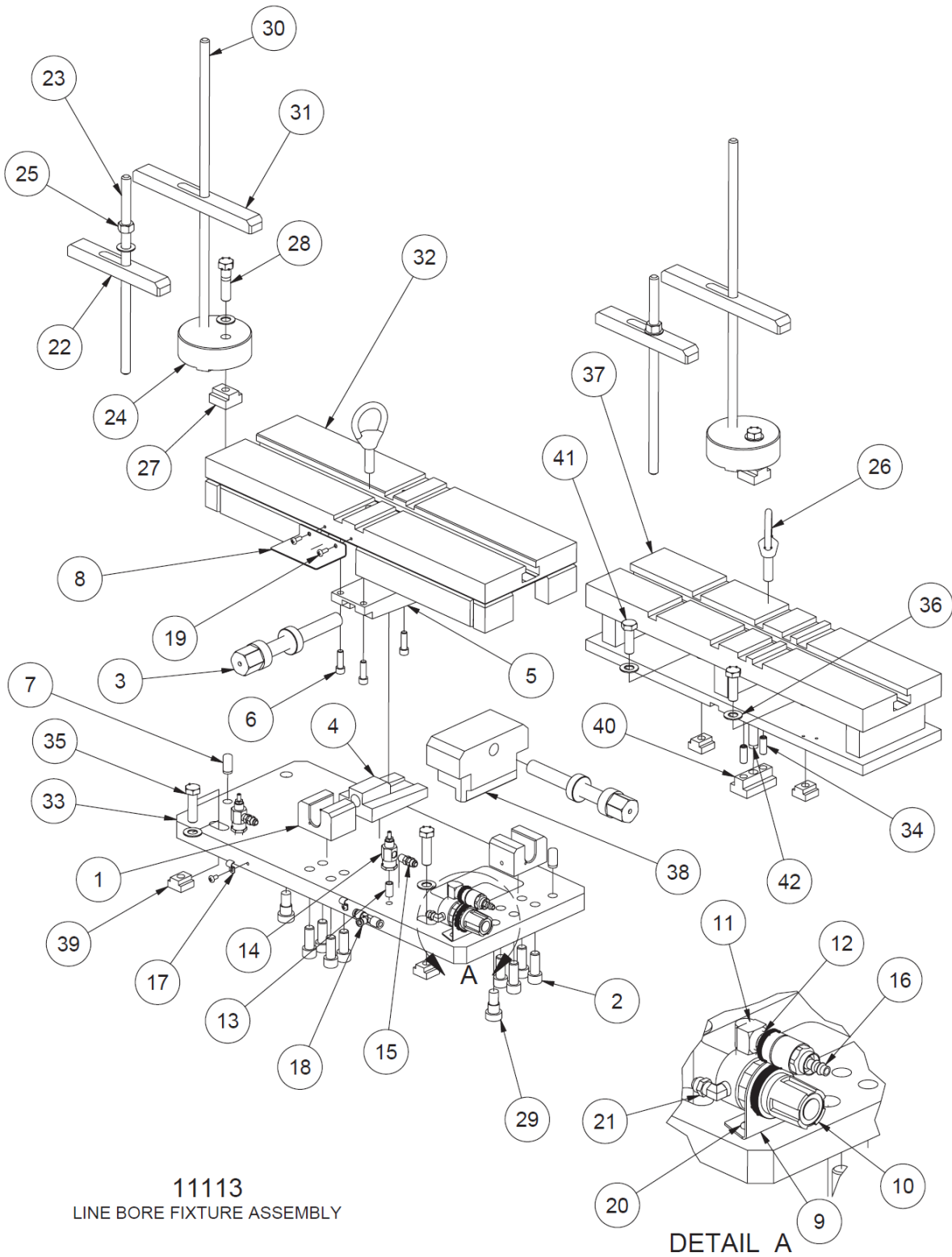

11113
LINE BORE FIXTURE ASSEMBLY

DETAIL A



11113 LINE BORE FIXTURE ASSEMBLY			
ITEM	QTY	PART NUMBER	DESCRIPTION
1	2	6829	BRACKET, SCREW – ADJUSTABLE PARALLEL
2	8	MF-43	SOCKET HEAD CAPSCREW 1/2-13 X 1 1/4"
3	2	6828	SCREW, ADJUSTABLE PARALLEL
4	1	6827	WEDGE, LOWER, ADJUSTABLE PARALLEL
5	1	6826	WEDGE, UPPER, ADJUSTABLE PARALLEL
6	3	MF-23	SOCKET HEAD CAPSCREW 5/16-18 X 1"
7	2	MF-213B	DOWEL PIN 1/2" X 1"
8	1	6834	CHIP SHIELD, UPPER PAD, ADJUSTABLE PARALLEL
9	1	502-27-17A	REGULATOR BRACKET
10	1	502-27-17	REGULATOR, 0-60
11	1	502-11-17S	STREET ELL, 1/4"
12	1	502-11-16X	QUICK CONNECT AIR FITTING, MALE
13	2	502-11-17J	NIPPLE, CLOSE, 1/8" NPT
14	2	502-11-35A	FLOW CONTROLLER
15	2	502-11-16E	CONNECTOR, MALE, 1/4 X 1/8 NPT
16	1	502-11-16W	QUICK CONNECT AIR FITTING, FEMALE
17	2	502-12-16	WIRE CLIP
18	1	514-4-17N	TEE, UNION, 1/4 TUBE
19	2	MF-110	PAN HEAD SCREW #10-24 X 1/2"
20	4	MF-111	PAN HEAD SCREW #10-24 X 3/8"
21	1	502-11-16I	ELBOW, MALE, 1/4 X 1/8" NPT
22	2	6833A	CLAMP BAR (7" LG), INLINE BLOCK
23	2	6833B	CLAMP ROD (12") INLINE BLOCK
24	2	6833	LOCATOR, IN-LINE BLOCK
25	2	MF-165	HEX NUT 1/2-13
26	2	502-2-13	LIFT EYE
27	2	502-1-11B	T-NUT, 3/4"
28	2	MF-149C	HEX HEAD CAPSCREW 1/2-13 X 2"
29	2	514-7-22	SCREW, SHOULDER
30	2	6833D	CLAMP ROD (18"), INLINE BLOCK
31	2	6833E	CLAMP BAR, INLINE BLOCK
32	1	11113G	UPPER PAD (MACHINING) – LINE BORE FIXTURE
33	1	11113B	LOWER PLATE (MACHINING) ADJUSTABLE PARALLEL
34	2	MF-70	SOCKET SET SCREW, FLAT POINT
35	2	MF-137F	HEX HEAD CAPSCREW 1/2-13 X 1 3/4"
36	8	MF-180	FLAT WASHER 1/2"
37	1	11113E	SUPPORT PARALLEL (MACHINING) 4" X 6"
38	1	11113D	BLOCK, ADJUSTING, ADJUSTABLE PARALLEL – LINE BORE FIXTURE
39	4	650-3-10	TN-5, T-NUT
40	1	11113A	LOCATING PIVOT KEY, LINE BORE FIXTURE
41	2	MF-150A	SOCKET HEAD CAPSCREW 1/2-13 X 1 1/2"
42	1	11113M	DOWEL PIN 1/2 X 1 1/2"

6843 90° V-Block Support Kit, Small Blocks

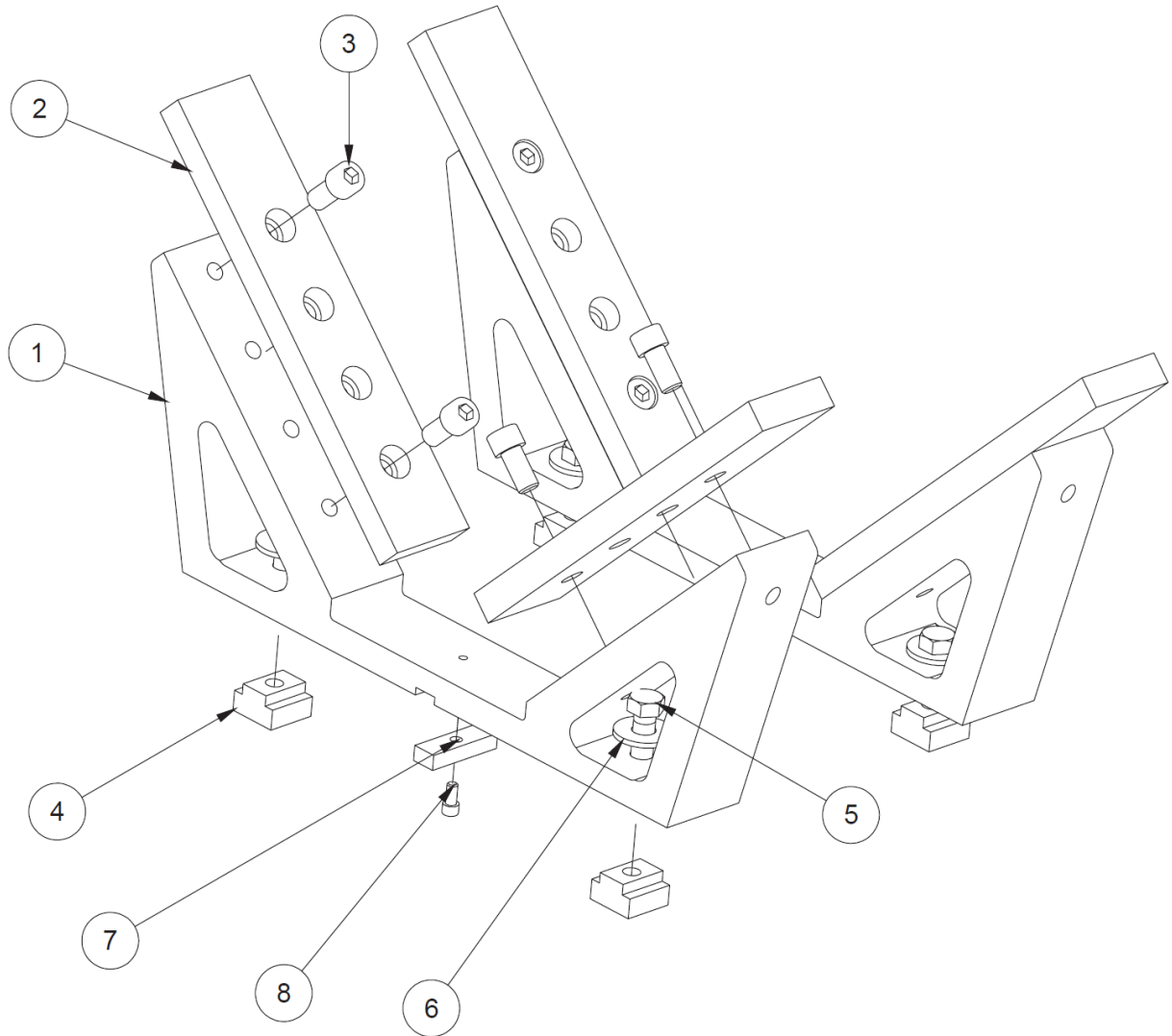

6843 90 DEG V-BLOCK CRADLE ASSEMBLY			
ITEM	QTY	PART NUMBER	DESCRIPTION
1	2	6843A	CRADLE, RIGHT AND LEFT, V-BLOCK
2	4	6789D	ADAPTER PLATE, V-BLOCK CRADLE
3	8	MF-42	S.H.C.S. 1/2-13 X 1"
4	4	502-1-11B	T-NUT, 3/4"
5	4	MF-15A	HEX BOLT, 1/2-13 X 1 1/2"
6	4	MF-180	FLAT WASHER, 1/2"
7	2	6831	KEY
8	2	MF-12	S.H.C.S. 1/4-20 X 1/2"

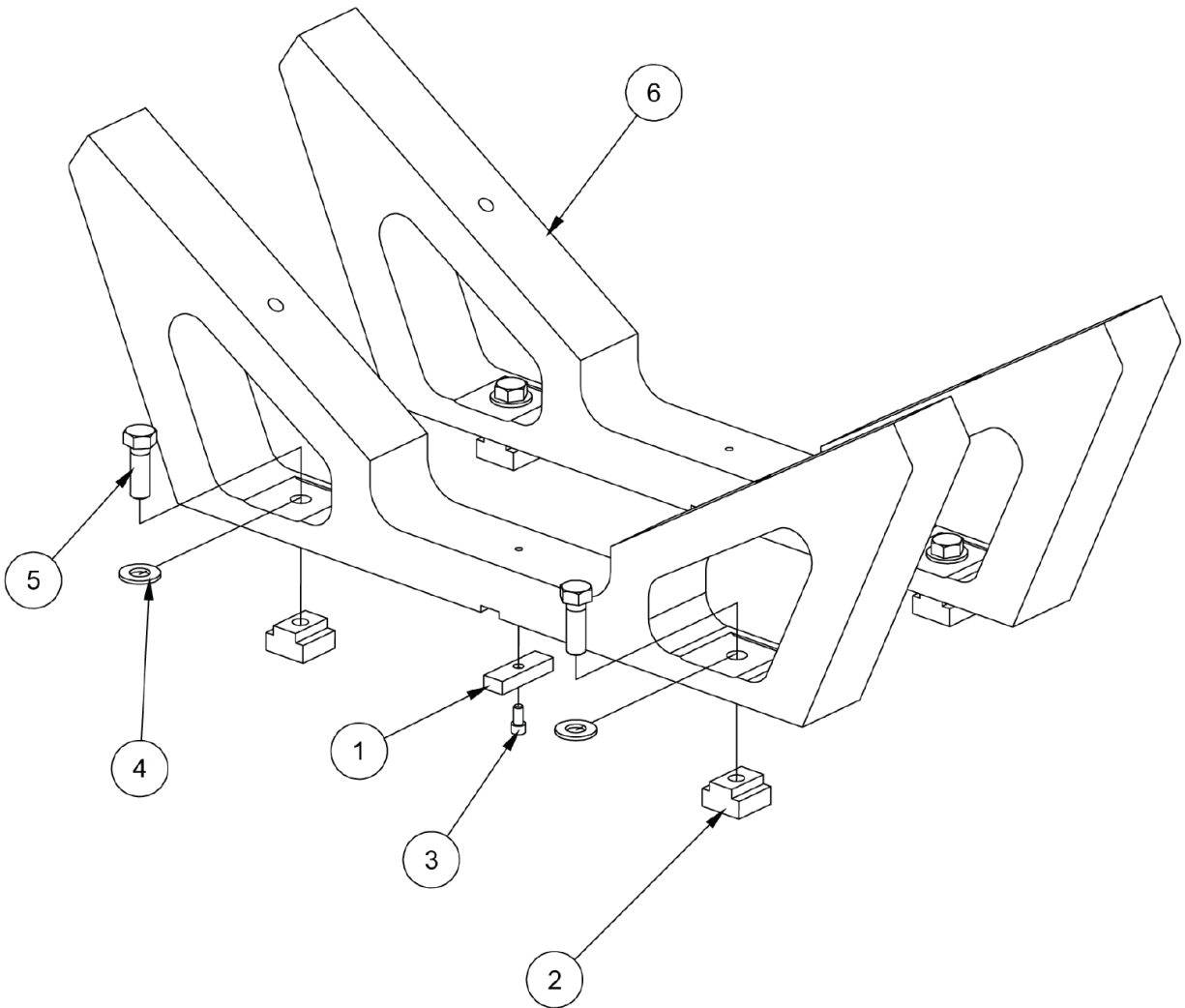
6789L 113° V-Block Support Kit

6789L 113 DEG V-BLOCK CRADLE ASSEMBLY			
ITEM	QTY	PART NUMBER	DESCRIPTION
1	2	6831	KEY, FIXTURE
2	4	502-1-11B	T-NUT, 3/4"
3	2	MF-12	S.H.C.S. 1/4-20 X 1/2"
4	4	MF-180	FLAT WASHER, 1/2"
5	4	MF-150A	HEX BOLT, 1/2-13 X 1 1/2"
6	2	6789M	CRADLE, DETROIT DIESEL V53 BLOCK, 113 DEG. 11'

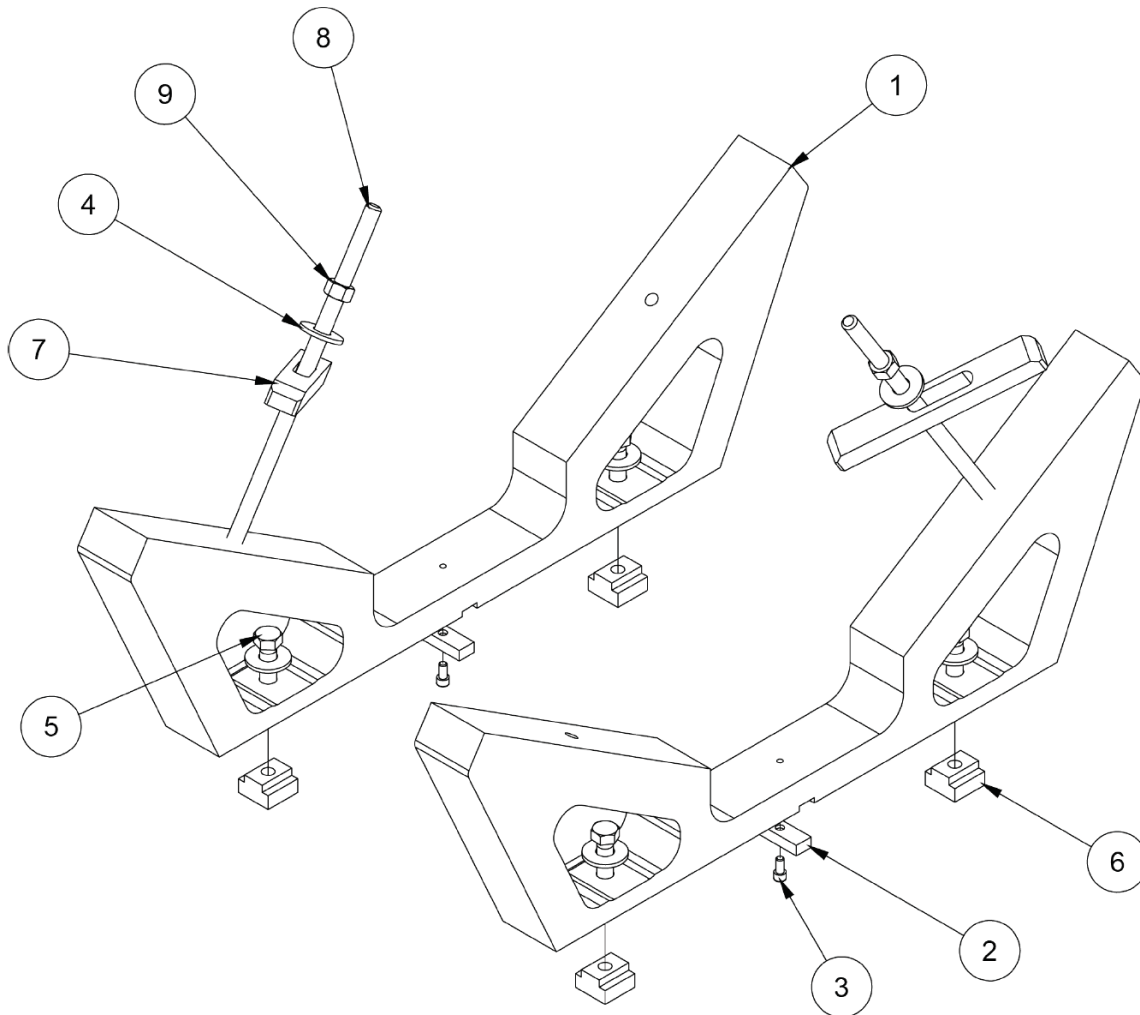
6789E 115° V-Block Support Kit

6789N 116 DEG 12 MIN V-BLOCK CRADLE ASSEMBLY			
ITEM	QTY	PART NUMBER	DESCRIPTION
1	2	6789F	115 DEG V-BLOCK CRADLE
2	2	6831	KEY, FIXTURE
3	2	MF-12	S.H.C.S. 1/4-20 X 1/2"
4	4	MF-180	FLAT WASHER, 1/2"
5	4	MF-150A	HEX BOLT, 1/2-13 X 1 1/2"
6	4	502-1-11B	T-NUT, 1/2-13
7	2	6833A	CLAMP BAR
8	2	6833B	CLAMP ROD
9	2	MF-165	HEX NUT, 1/2-13

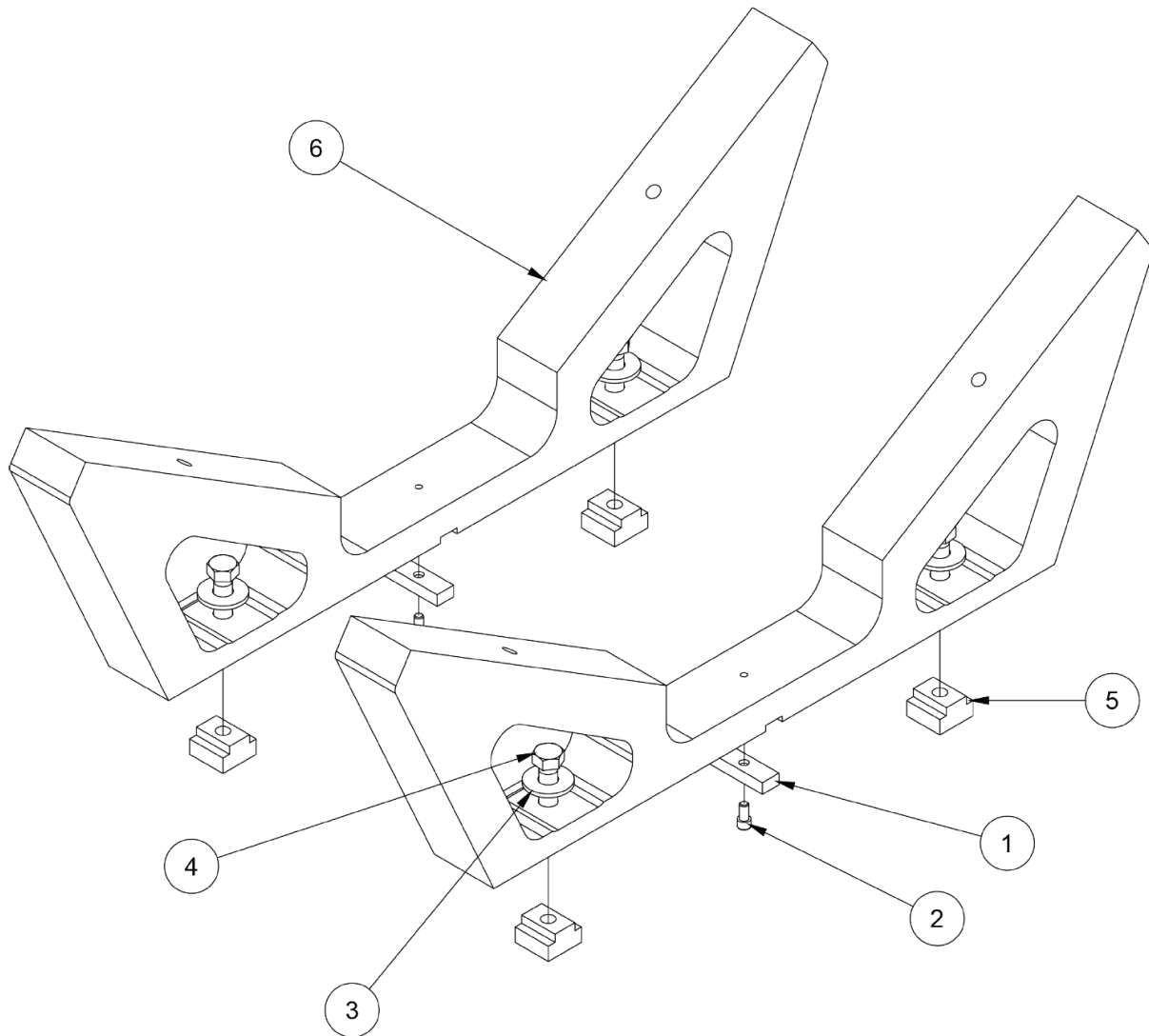
6789N 116° V-Block Support Kit

6789N 116 DEG 12 MIN V-BLOCK CRADLE ASSEMBLY			
ITEM	QTY	PART NUMBER	DESCRIPTION
1	2	6831	KEY, FIXTURE
2	2	MF-12	S.H.C.S. 1/4-20 X 1/2"
3	4	MF-180	FLAT WASHER, 1/2"
4	4	MF-150A	HEX BOLT, 1/2-13 X 1 1/2"
5	4	502-1-11B	T-NUT, 1/2-13
6	2	6789P	116 DEG 12' V-BLOCK CRADLE

6866 Wedge for Cummins 5.9L Camshaft Line Boring Parts

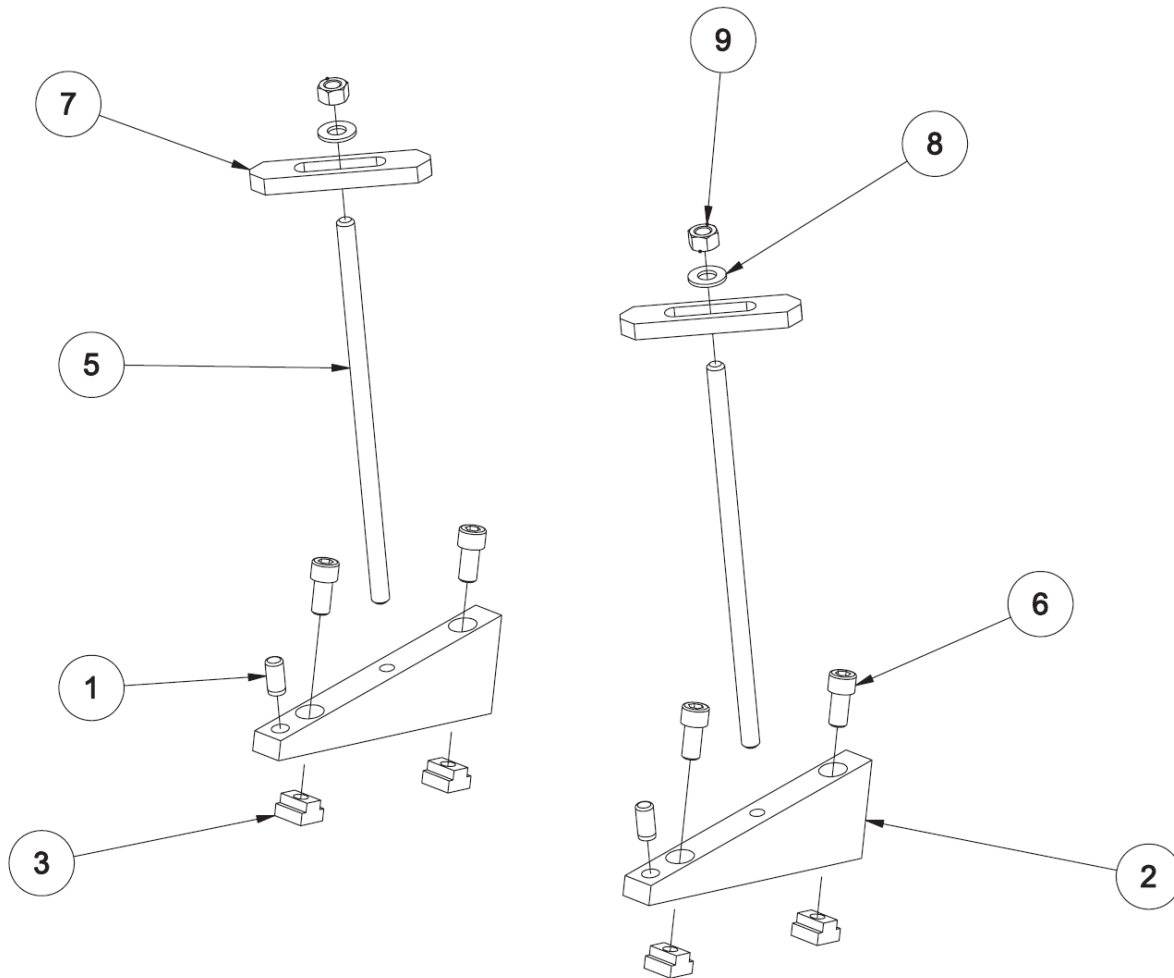

ITEM	QTY	PART NUMBER	DESCRIPTION
1	2	MF-213B	DOWEL PIN 1/2 X 1"
2	2	6866A	15° WEDGE, CUMMINS DIESEL CAM BORE FIXTURE
3	4	7137B	T-NUT
5	2	6833B	CLAMP ROD, 12"
6	4	MF-42	SOCKET HEAD CAPSCREW 1/2-13 X 1"
7	2	650-3-57B	CLAMP BAR
8	2	MF-180	FLAT WASH 1/2"
9	2	MF-165	HEX NUT 1/2-13

Miscellaneous Fixtures/Accessories

650-3-37 1/2" (12.7mm) Clamp Kit

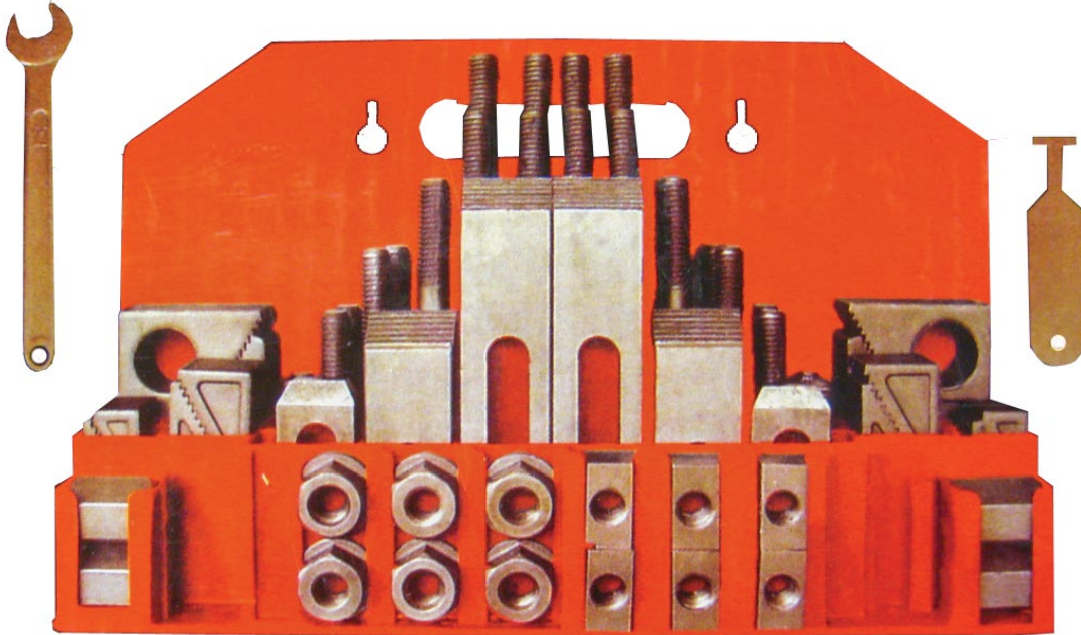

7209M Dual Axis Leveling Table

7209M Leveling Table Sections

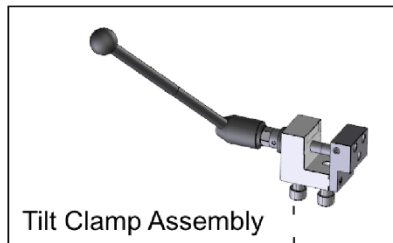
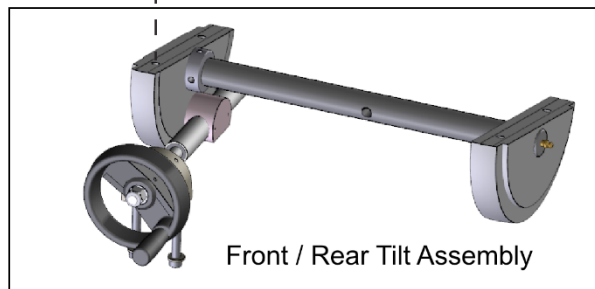
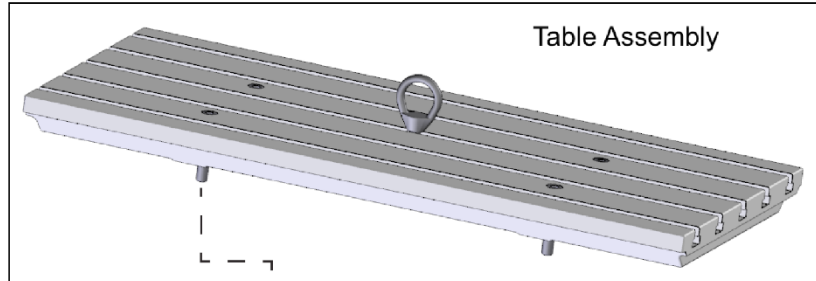

Tensioner Assembly

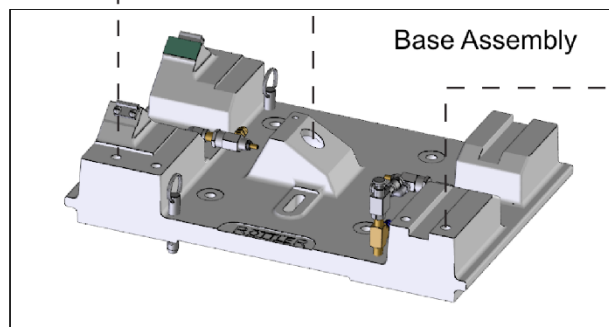
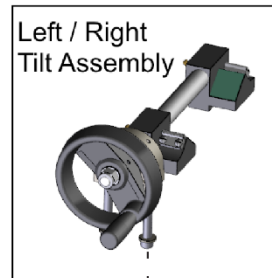

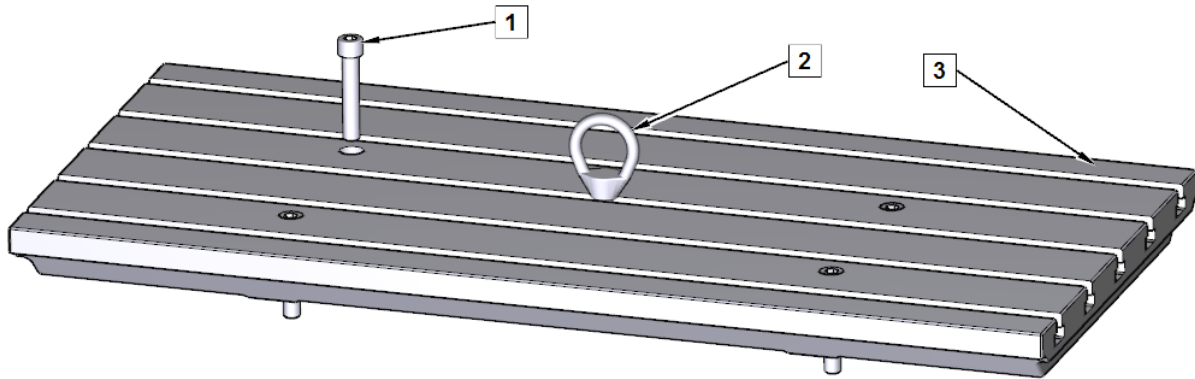

ITEM	QTY	PART NUMBER	DESCRIPTION
1	4	MF-45	SOCKET HEAD CAPSCREW, 1/2-13 X 2"
2	1	502-3-13	EYE, LIFTING
3	1	7207C	TABLE, DUAL AXIS HEAD FIXTURE

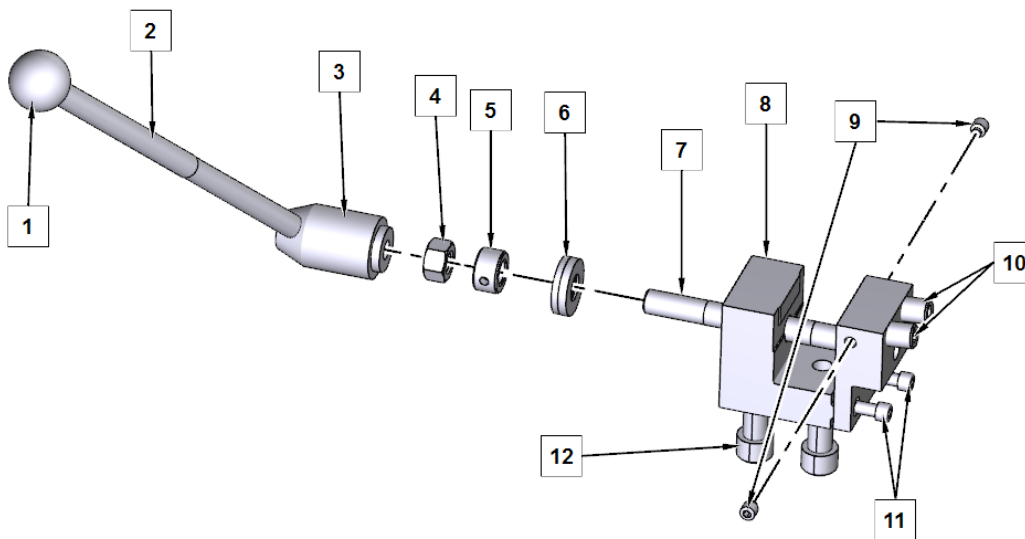

ITEM	QTY	PART NUMBER	DESCRIPTION
1	1	514-2-39E	KNOB, ADJUSTABLE HANDLE
2	1	514-2-39B	EXTENDER, ADJUSTABLE HANDLE
3	1	514-2-39D	HANDLE, ADJUSTABLE – CLAMP STOP
4	1	MF-165	HEX NUT, 1/2-13
5	1	7209J	COLLAR, 1/2" SHAFT
6	1	7209E	WASHER, SPHERICAL
7	1	7207Z	SHAFT, JOURNAL CLAMP
8	1	7210J	CLAMP BLOCK, JOURNAL CLAMP
9	2	504-29-36	SCREW, SET – BRASS TIPPED 5/16-18 X 5/16"
10	2	7209B	SCREW, SET – BRASS TIPPED 1/2-20 X 3/4"
11	2	MF-12	SOCKET HEAD CAP SCREW, 1/4-20 X 1/2"
12	2	MF-45	SOCKET HEAD CAP SCREW, 1/2-13 X 2"

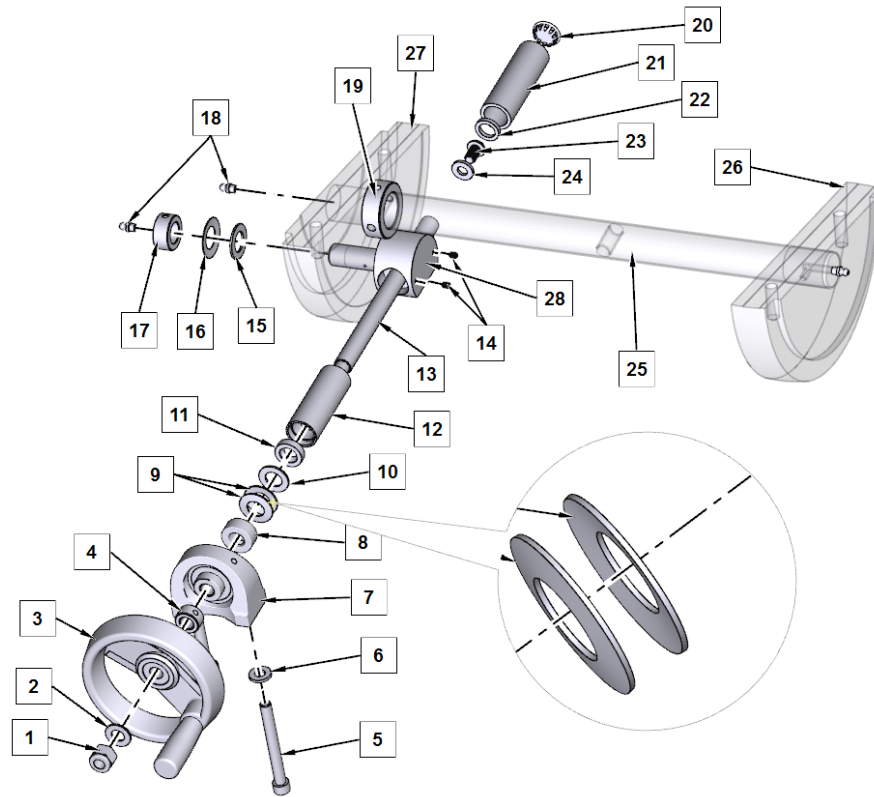

ITEM	QTY	PART NUMBER	DESCRIPTION
1	1	MF-186	NYLOCK NUT, 1/2-13
2	1	100-19	WASHER, THRUST
3	1	7201M	HANDWHEEL
4	1	7209J	COLLAR, 1/2" SHAFT
5	2	MF-36A	SOCKET HEAD CAPSCREW, 3/8-16 X 3 1/2"
6	2	100-28-32	WASHER, 3/32" THICK
7	1	7201D	BLOCK, PILLOW, LEVEL ADJUST
8	1	7199E	COLLAR, SUPPORT BLOCK (5/8" DIA)
9	2	514-7-21	WASHER, BELLEVILLE
10	1	514-7-20	WASHER, THRUST
11	1	7209F	SEAL, PIVOT NUT TUBE
12	1	7201Y	TUBE, SEALED - PIVOT NUT
13	1	7209Q	SHAFT, FRONT/REAR TABLE TILT
14	2	MF-52	SOCKET SET SCREW, CUP POINT, #10-24 X 1/4"
15	1	514-2-90	WASHER, THRUST
16	1	7209K	WASHER, BELLEVILLE - PIVOT NUT
17	1	7201X	COLLAR, PIVOT NUT
18	2	MF-189	1/4-28 STRAIGHT LUBE GREASE FITTING
19	1	7207X	COLLAR, CLAMP BAR - 1 1/4"
20	1	506-3-1	PLUG, SNAP-IN HOLE - 7/8"
21	1	7201T	TUBE, CAPPED - PIVOT NUT
22	1	514-7-35	O-RING, LEVELING TABLE
23	1	MF-97	SOCKET BUTTON HEAD SCREW 3/8-16 X 5/8"
24	1	100-28-32	WASHER, 3/32"
25	1	7207V	BAR, CLAMP
26	1	7207J	JOURNAL, RIGHT
27	1	7207H	JOURNAL, LEFT

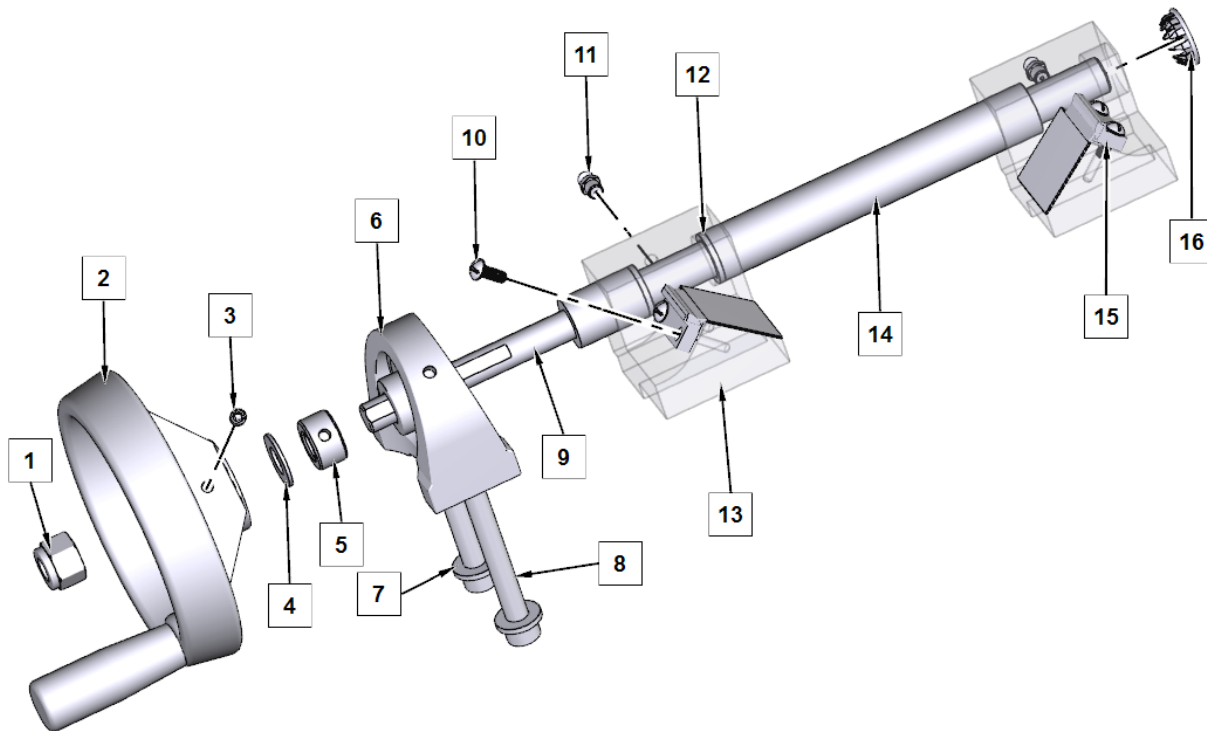

ITEM	QTY	PART NUMBER	DESCRIPTION
1	1	MF-186	NYLOCK NUT, 1/2-13
2	1	7201M	HANDWHEEL
3	1	MF-60	SOCKET SET SCREW, CUP POINT, 1/4-20 X 1/4"
4	1	100-19	WASHER, THRUST
5	1	7209J	COLLAR, 1/2" SHAFT
6	1	7201D	BLOCK, PILLOW, LEVEL ADJUST
7	2	100-28-32	WASHER, 3/32" THICK
8	2	MF-36A	SOCKET HEAD CAPSCREW, 3/8-16 X 3 1/2"
9	1	7207M	SHAFT, LEFT/RIGHT TILT
10	1	MF-111	ROUND HEAD MACHINE SCREW, #10-24 X 1/2"
11	1	MF-189	1/4-28 STRAIGHT LUBE GREASE FITTING
12	1	7209H	BUMPER, LEFT/RIGHT PIVOT
13	1	7222	BLOCK, FRONT BEARING
14	1	7207N	COVER, LEFT/RIGHT TILT SHAFT
15	1	7198Y	WIPER, JOURNAL
16	1	506-3-1	PLUG, SNAP-IN HOLE - 7/8"

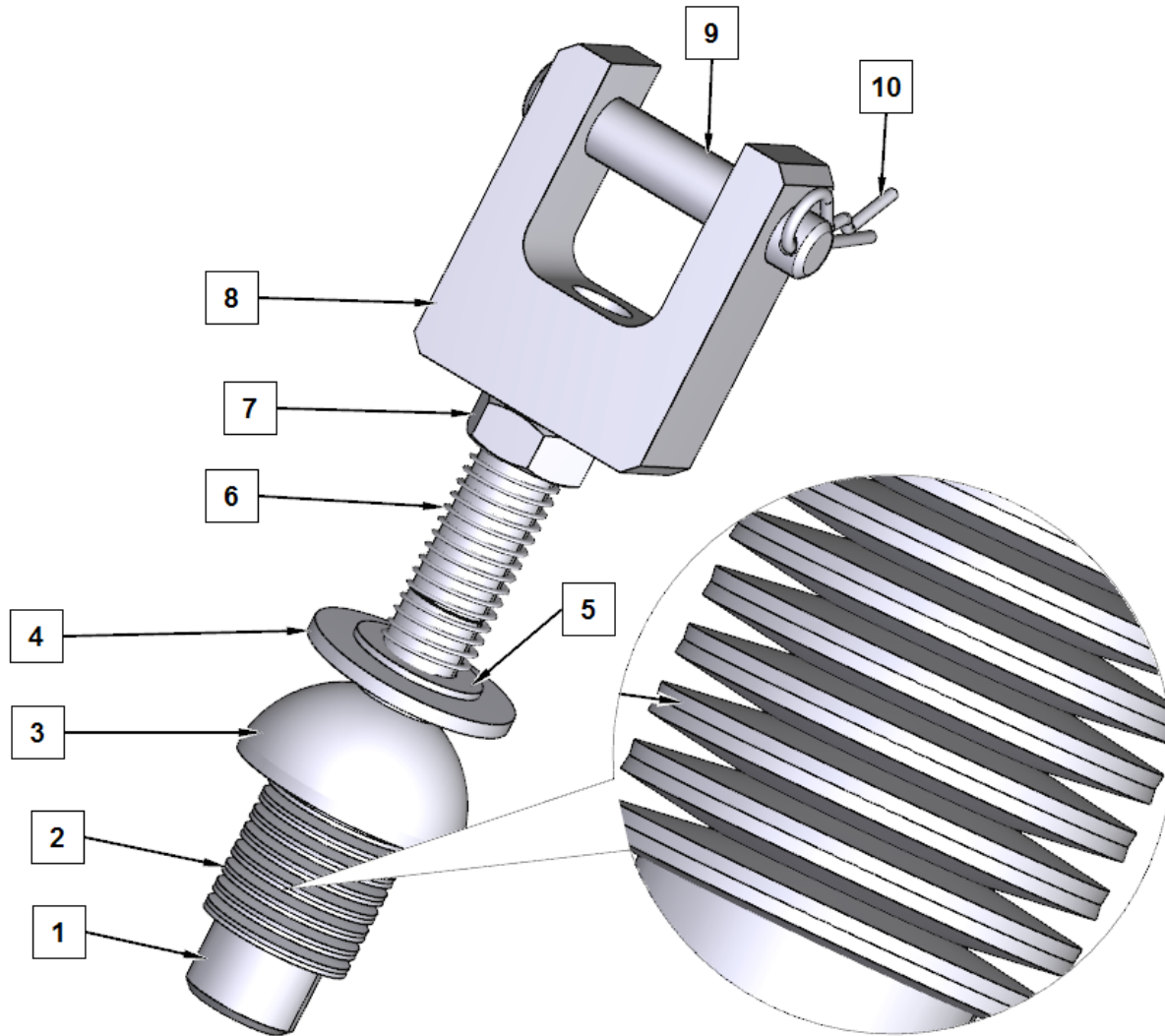

ITEM	QTY	PART NUMBER	DESCRIPTION
1	1	7209W	SCREW, CLAMP BAR
2	16	514-7-21	WASHER, BELLEVILLE
3	1	7209U	WASHER, SPHERICAL – HOLD DOWN
4	1	MF-181	FLAT WASHER, 5/8"
5	1	514-7-20	WASHER, THRUST
6	1	100-28-20C	SPRING, HOLD DOWN
7	1	MF-173	HEX JAM NUT, 5/8-11
8	1	7209S	ROD END, CLAMP BAR
9	1	7210B	PIN, CLEVIS
10	1	7232K	HITCH PIN CLIP

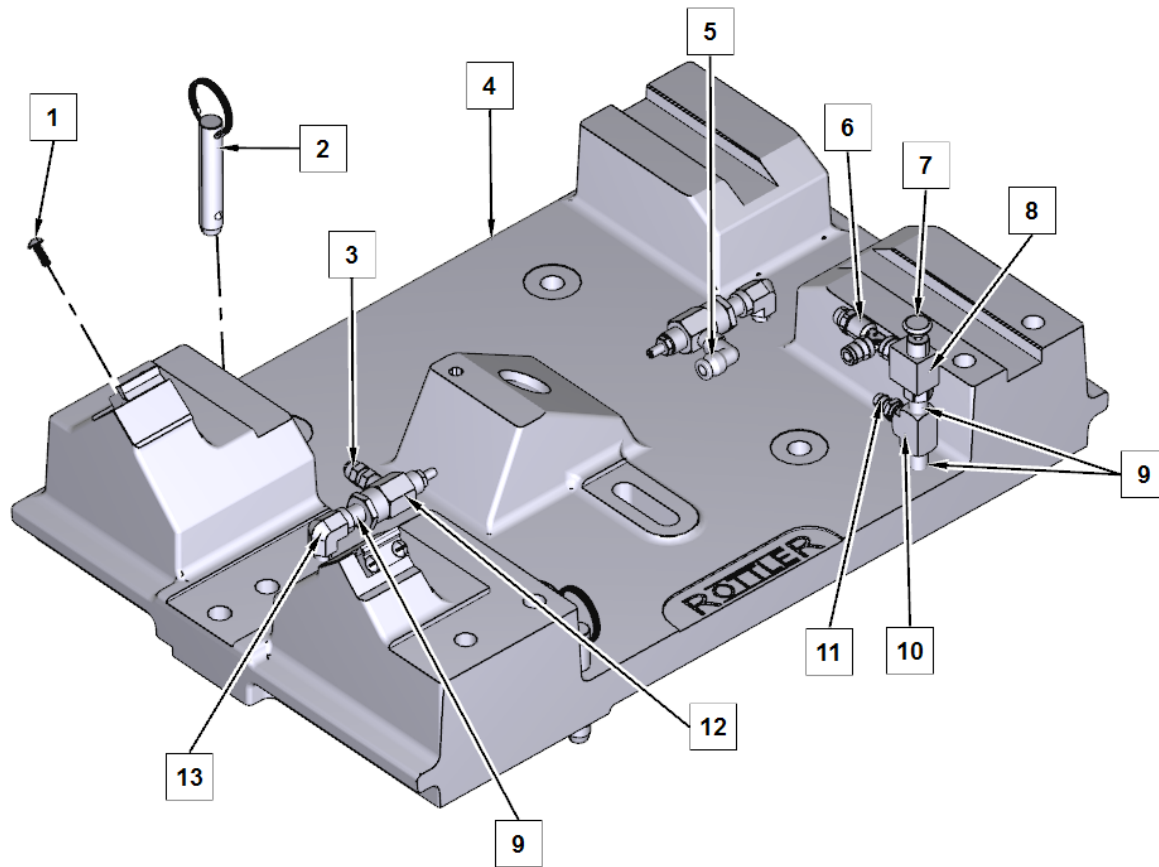

ITEM	QTY	PART NUMBER	DESCRIPTION
1	4	MF-11	ROUND HEAD MACHINE SCREW, #10-24 X 1/2"
2	1	7201C	PIN, GUIDE, ROTTLER LEVELING TABLE
3	1	502-11-16E	CONNECTOR, MALE, 1/4 X 1/8" NPT
4	1	7233	FRAME, TABLE
5	1	514-4-17E	ELBOW, 90 DEGREE MALE - 1/4 X 1/8" NPT
6	1	514-4-17X	TEE, RUNNING 1/8" NPT X 1/4"
7	1	502-1-56	PUSHBUTTON
8	1	514-2-65	VALVE, AIR - LIMIT & STOP
9	2	502-11-17J	NIPPLE, CLOSE 1/8" NPT
10	1	502-11-17C	TEE, 1/8" X 1/8"
11	1	502-1-96A	INSERT, BARBED - HOSE
12	2	502-11-35A	VALVE, CONTROL - RFC FLOW
13	2	502-11-17R	ELBOW, ST, 1/8" NPTF X 1/8" NPTM

7209N 2-Piece Vise

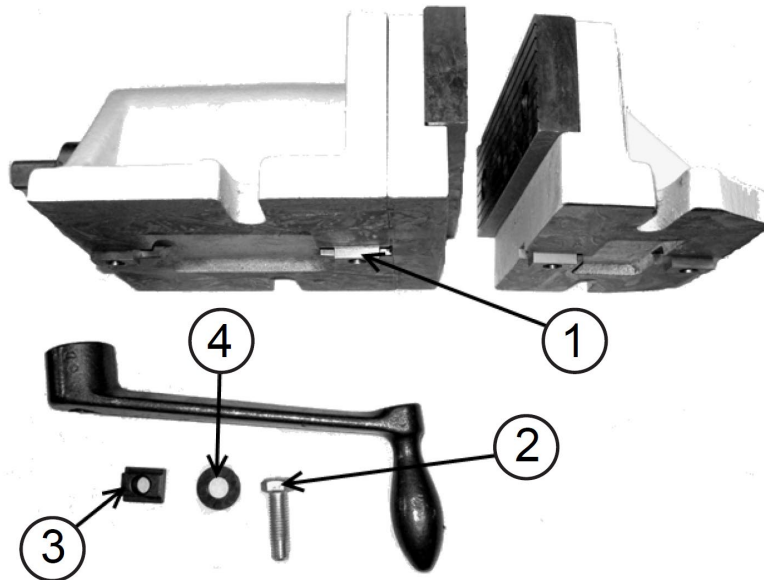

ITEM	QTY	PART NUMBER	DESCRIPTION
1	1	7210E	KEY, STEPPED
2	1	MF-137F	HEX BOLT, 1/2-13 X 1 3/4"
3	1	7137B	NUT, "T"
4	1	100-19A	WASHER, HARDENED 17/32" I.D.

11111 Tower Type Block Hold-down Clamp Kit

11111 CLAMP TOWER ASSEMBLY			
ITEM	QTY	PART NUMBER	DESCRIPTION
1	2	6309J	BASE ASSEMBLY, BLOCK CLAMP
2	2	11111A	CLAMP LEG ASSEMBLY
3	4	650-3-10	NUT, "T", HARDENED
4	4	MF-180	FLAT WASHER 1/2"
5	4	MF-137F	HEX BOLT 1/2-13 X 1 3/4"

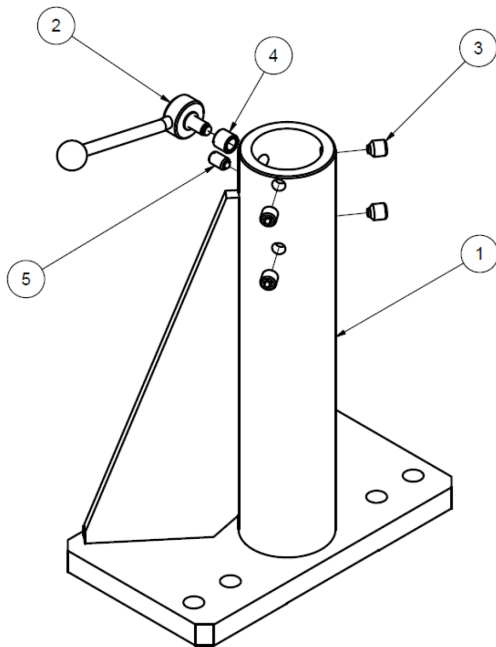
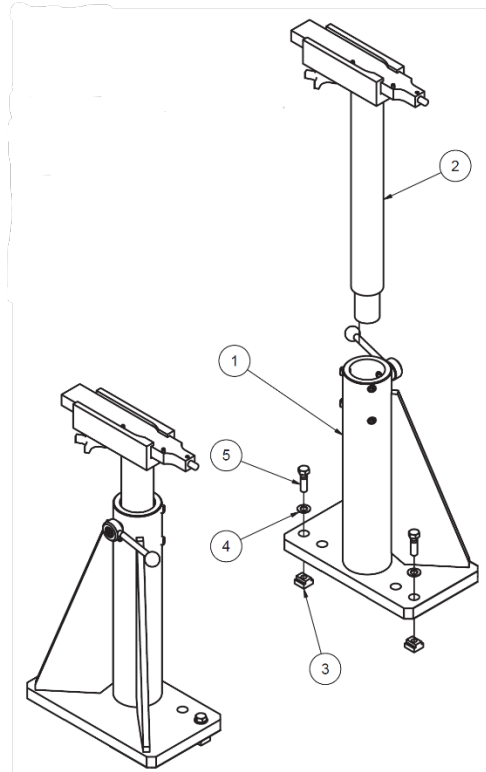

6309J CLAMP TOWER BASE ASSEMBLY			
ITEM	QTY	PART NUMBER	DESCRIPTION
1	1	6309L	BLOCK CLAMP BASE
2	1	6310N	HANDLE ASSEMBLY, CLAMP TOWER
3	4	6310Y	SET SCREW, BRASS TIPPED
4	1	6310R	THREAD INSERT
5	1	502-8-52C	SPRING PLUNGER

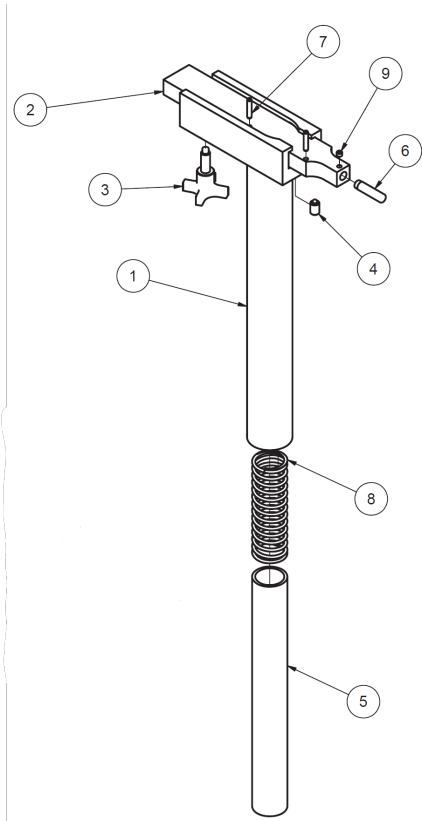

6310 CLAMP LEG ASSEMBLY			
ITEM	QTY	PART NUMBER	DESCRIPTION
1	1	6310T	CLAMP LEG WELDMENT
2	1	6310H	CLAMP SHOE
3	1	6310K	HAND KNOB
4	1	502-8-52C	SPRING PLUNGER
5	1	6310P	SPACER, LONG SPRING SHOCK, F90 CLAMP LEG
6	1	MF-214	DOWEL PIN, 1/2" X 2"
7	2	MF-227	ROLL PIN, 1/4" X 1 1/4"
8	1	6310S	SPRING
9	1	MF-67	SET SCREW, FLAT POINT, 5/16-18 X 1/4"

7152A Dual Axis Level

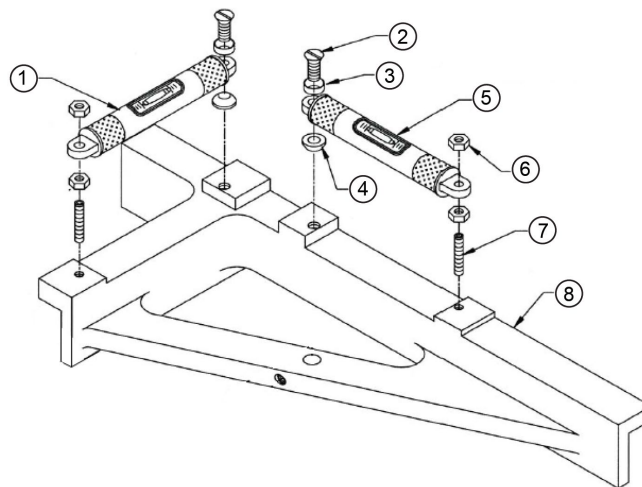

ITEM	QTY	PART NUMBER	DESCRIPTION
1	1	7152	VIAL ONLY, LEVEL SF
2	2	7153G	SCREW, FLAT HEAD, #12-24, SURFACING LEVEL
3	2	7153Z	WASHER, LEVEL MOUNTING (COUNTERSUNK HEAD)
4	2	7153V	WASHER, LEVEL MOUNTING (RADIUS HEAD)
5	1	7152C	COMPLETED VIAL, LONGITUDINAL SF LEVEL ASS'Y
6	4	7153H	NUT, #12-24, HEAD SURFACING LEVEL
7	2	7153J	SCREW, SOCKET SET #12-24 X 1" SURFACING LEVEL
8	1	7153S	BASE, HEAD SURFACE LEVEL

9111A T-Slot Plate for F60 Model Fixtures

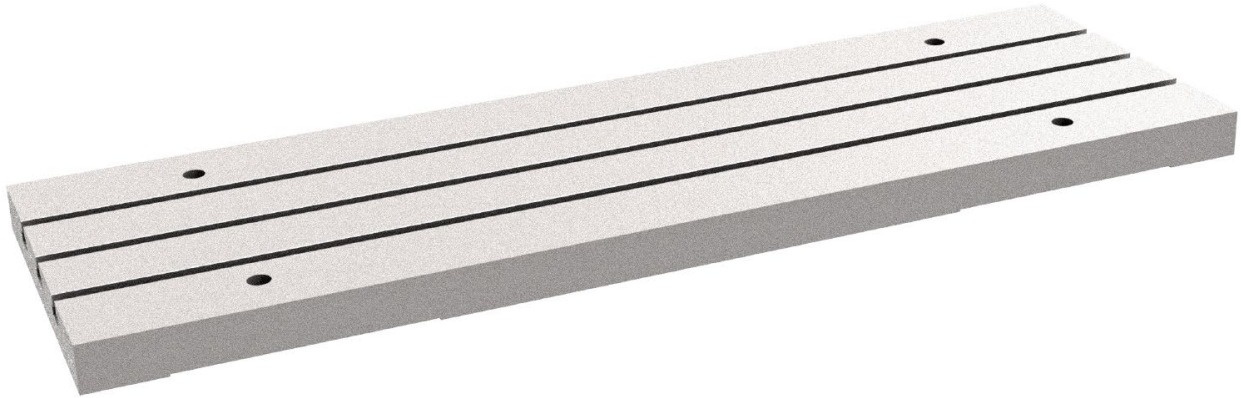

650-2-60N Setting Fixture, Lifter Tooling Package



Auxiliary Equipment

10110 Renishaw Wireless Radio Probing System Kit



ITEM	QTY	PART NUMBER	DESCRIPTION
1	1	650-2-44L	CAT 40 RETENTION KNOB
2	1	6648P	CAT 40 SHANK
3	1	650-3-59Z	PROBE, RMP40
4	1	650-3-59C	50mm LONG X 6mm DIA STYLUS PROBE
5	1	650-3-59K	STYLUS EXTENSION (50mm)
6	1	650-3-59D	100mm LONG X 6mm DIA STYLUS PROBE
7	1	6648T	STYLUS EXTENSION
8	1	6648R	SWIVEL ADAPTER FOR STYLUS
9	1	6648U	LITHIUM BATTERY
10	1	650-3-59E	20mm LONG X 2mm DIA STYLUS PROBE
11	1	6648Q	17.5mm LONG X 6mm DIA STYLUS PROBE
12	1	6648S	CRASH PROTECTION DEVICE FOR STYLUS

502-12-7B Digital Runout Probe and Readout Kit

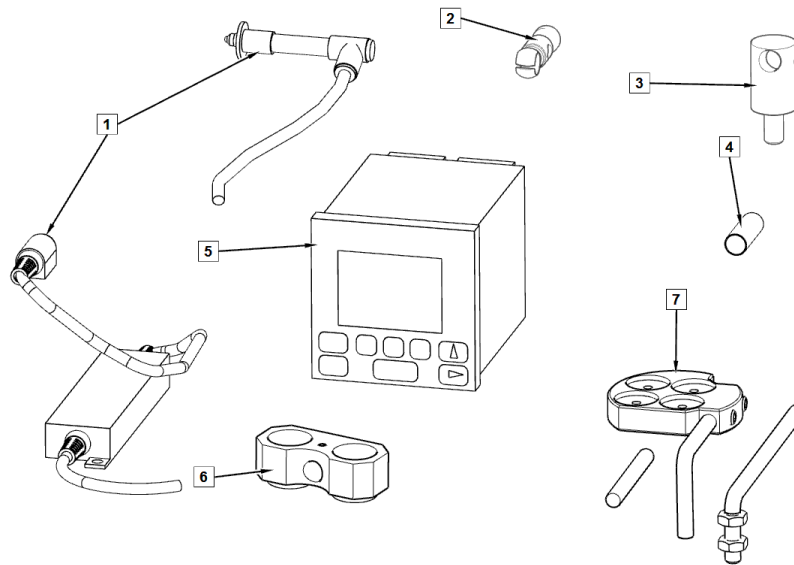

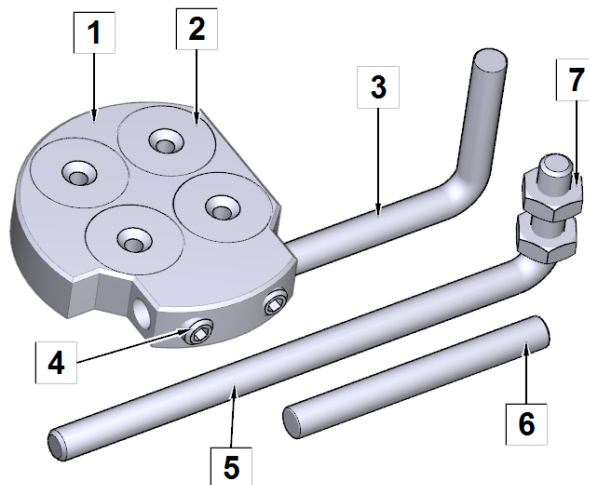

ITEM	QTY	PART NUMBER	DESCRIPTION
1	1	502-12-7C	DIGITAL GAUGE
2	1	502-11-40	CLAMP BODY
3	1	502-9-9S	INDICATOR MOUNT, RIGHT ANGLE DRIVE
4	1	502-12-7E	GAUGE ADAPTER SLEEVE
5	1	502-12-7D	1-AXIS GAGING DISPLAY – DIGITAL RUNOUT GAUGE
6	1	502-12-4A	MAGNETIC HOLDER ASSEMBLY
7	1	502-12-4	MAGNETIC HOLDER ASSEMBLY

502-12-4 General Purpose Magnetic Indicator Holder

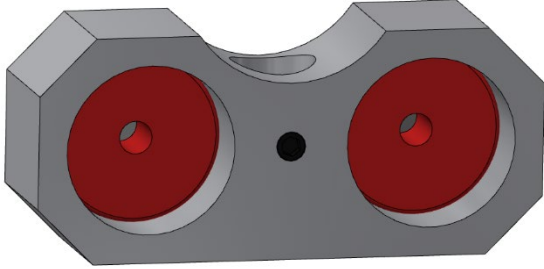

ITEM	QTY	PART NUMBER	DESCRIPTION
1	1	502-11-39A	HOLDER, MAGNET
2	4	502-11-39	MAGNETS, SHALLOW POT
3	1	502-11-39B	ROD, ADAPTER, RIGHT ANGLE – SHORT
4	2	MF-58	SOCKET SET SCREW, FLAT POINT, 1/4-20 X 1/4"
5	1	502-11-39Q	ROD, ADAPTER, RIGHT ANGLE – LONG
6	1	MF-208	DOWEL PIN 1/4" X 2 1/4"
7	2	MF-163	HEX NUT 1/4-20

<p>502-9-9A Mechanical Runout Indicator, Inch</p>  <p>A mechanical runout indicator with a circular dial. The dial has a yellow background with black markings and numbers from 0 to 10. The brand name 'Starrett' is printed in red on the dial. The dial also includes the text 'No. 711', 'LAST MADE', and 'UP-DOWN'. The indicator has a black body with a knurled adjustment knob on top and a horizontal shaft with a ball tip at the end.</p>	<p>502-9-9J Mechanical Runout Indicator, Metric</p>  <p>A mechanical runout indicator with a circular dial. The dial has a white background with black markings and numbers from 0 to 30. The brand name 'Starrett' is printed in red on the dial. The dial also includes the text 'No. 711 m', 'LAST MADE', and 'UP-DOWN'. The indicator has a silver body with a knurled adjustment knob on top and a horizontal shaft with a ball tip at the end.</p>
<p>502-9-9S Indicator Mount</p>  <p>A dark-colored, cylindrical indicator mount with a tapered end. It has a circular opening on the side with a small hole in the center.</p>	<p>502-12-4A Magnetic Indicator Holder</p>  <p>A grey, octagonal magnetic indicator holder with two large red circular openings on the front face. A small black circular hole is located between the two red openings.</p>

650-3-44S Precision Connecting Rod Fixturing System
For 8-24" (203-610mm) Long Rods

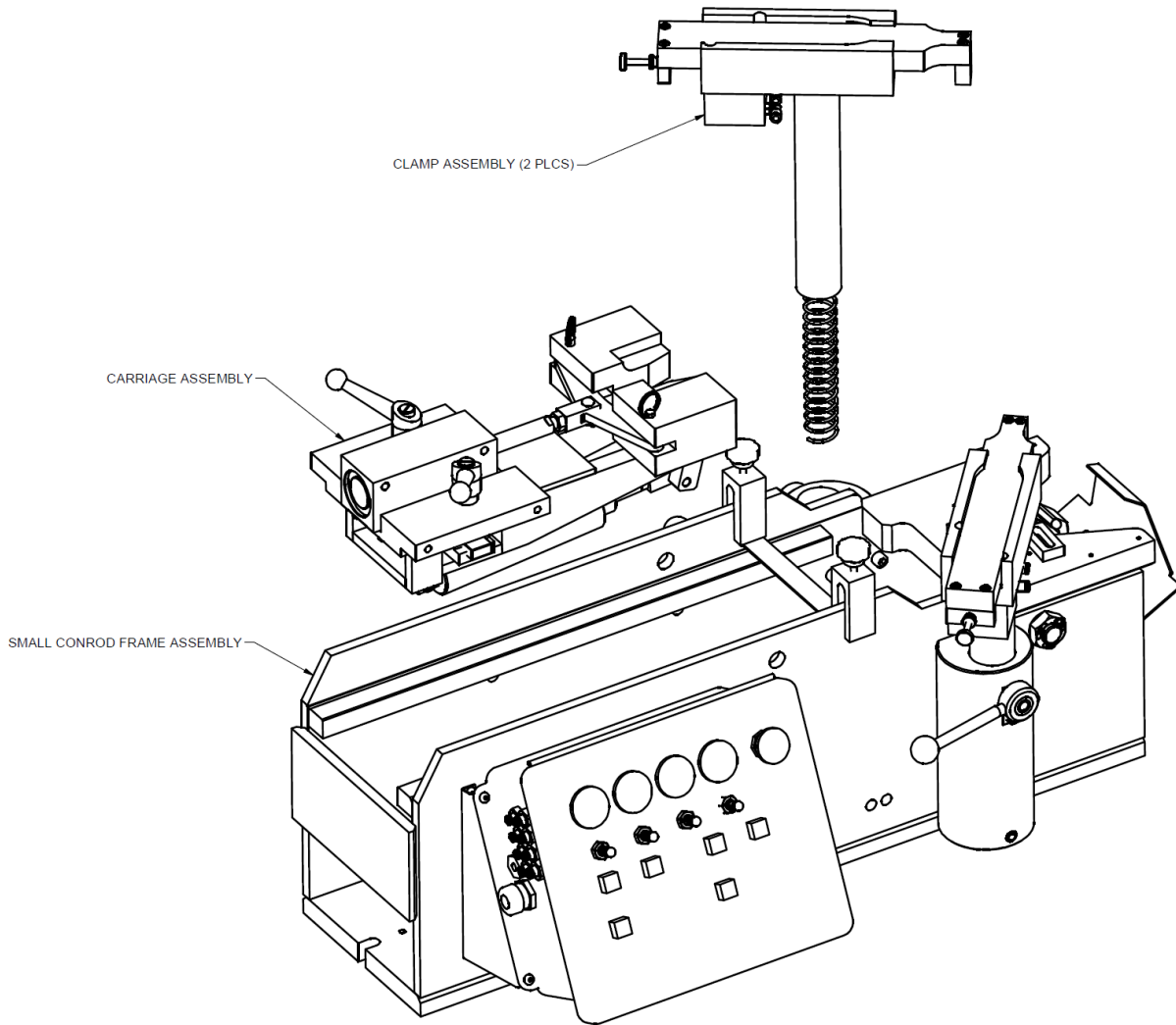

Conrod Frame Assembly

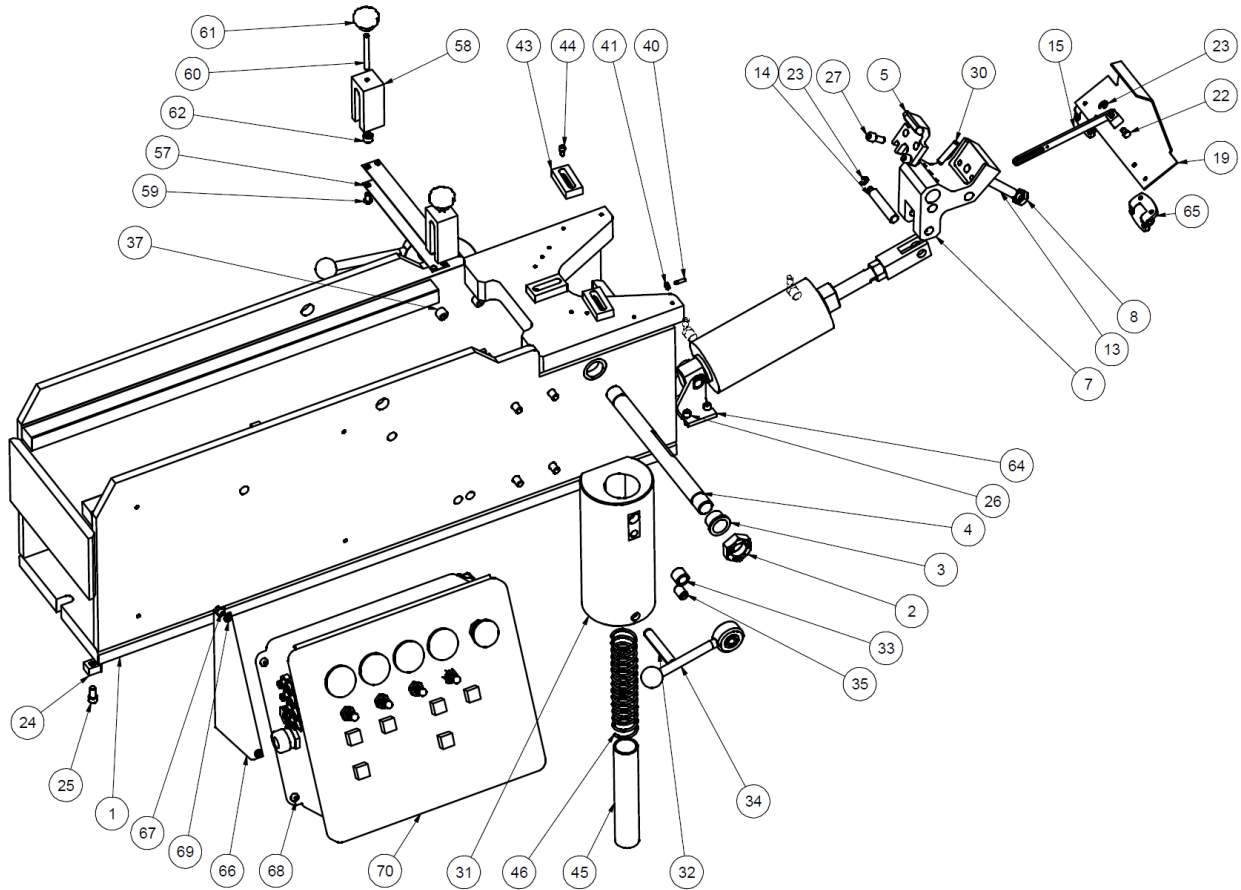



CONROD FRAME ASSEMBLY			
ITEM	QTY	PART NUMBER	DESCRIPTION
1	1	650-3-6-67B	BASE, FRAME
2	2	650-3-46T	LOCK NUT, REID BLN-105
3	2	650-3-46U	FLANGE BEARING, SYMMCO SF-2832-12
4	1	650-3-46G	PIVOT SHAFT
5	1	650-3-46V	LOCATOR 2.50
7	1	650-3-46J	LOCATOR HOLDER
8	1	MF-171	HEX JAM NUT, 1/2-13
13	1	650-3-47K	STOP SCREW
14	1	650-3-46K	PIVOT PIN
15	1	650-3-46L	LINKAGE ARM
19	1	650-3-46Q	LOCATOR COVER CONROD FIXTURE
22	1	650-3-46H	LINKAGE PIN
23	2	650-3-46R	E-CLIP – TRUEARC E-RING #RE-25ST
24	2	650-3-9	KEY
25	2	MF-21	SOCKET HEAD CAPSCREW, 5/16-18 X 5/8"
26	4	MF-13	SOCKET HEAD CAPSCREW, 1/4-20 X 5/8"
27	2	MF-22	SOCKET HEAD CAPSCREW, 5/16-18 X 3/4"
28	2	MF-53	SOCKET SET SCREW, CUP POINT, #10-24 X 3/8"
29	2	MF-60	SOCKET SET SCREW, CUP POINT, 1/4-20 X 1/4"
30	1	MF-228	ROLL PIN 5/16" X 1 1/2"
31	2	650-3-49Q	CLAMP BASE, CONROD CLAMP ARMS
32	2	MF-230B	ROLL PIN 1/2" X 3"
33	2	6310R	THREAD INSERT
34	2	6310J	CLAMP HANDLE
35	2	502-8-52C	SPRING PLUNGER
37	8	MF-31	SOCKET HEAD CAPSCREW, 3/8-16 X 1"
40	1	650-3-48P	SPRING ANCHOR, REID CSA-50
41	1	MF-160	HEX NUT, #8-32
42	1	514-7-83N	EXTENSION SPRING
43	3	650-3-48L	SUPPORT PARALLEL
44	3	MF-4	SOCKET HEAD CAPSCREW, #10-24 X 3/8"
45	2	650-3-49G	CLAMP LEG SPACER TUBE
46	2	650-3-49M	SPRING
57	2	650-3-47B	SUPPORT STRAP
58	2	650-3-47C	SUPPORT STRAP HOLDER
59	4	MF-90	SOCKET BUTTON HEAD SCREW, 1/4-20 X 1/2"
60	2	MF-74	SET SCREW, 1/4-20 X 2 1/2"
61	2	514-6-86	PLASTIC KNOB
62	2	650-3-47L	FOOT, SUPPORT STRAP
63	1	650-3-45G	CENTERING CYLINDER, CONROD FIXTURE ASSEMBLY
64	1	650-3-45H	PIVOT BRACKET, BIMBA #D-13512-A
65	2	650-3-46S	HINGE, LOCATOR COVER, CONROD FIXTURE ASSEMBLY
66	2	650-3-65D	BRACKET, CONTROL BOX, CONROD FIXTURE
67	4	MF-248	SOCKET BUTTON HEAD SCREW, 1/4-20 X 3/8"
68	4	MF-91	SOCKET BUTTON HEAD SCREW, 1/4-20 X 5/8"
69	4	650-3-47W	RIVET NUT, REID ALC-47850
70	1	650-3-47T	CONTROL BOX, CONROD FIXTURE ASSEMBLY

Conrod Carriage Assembly

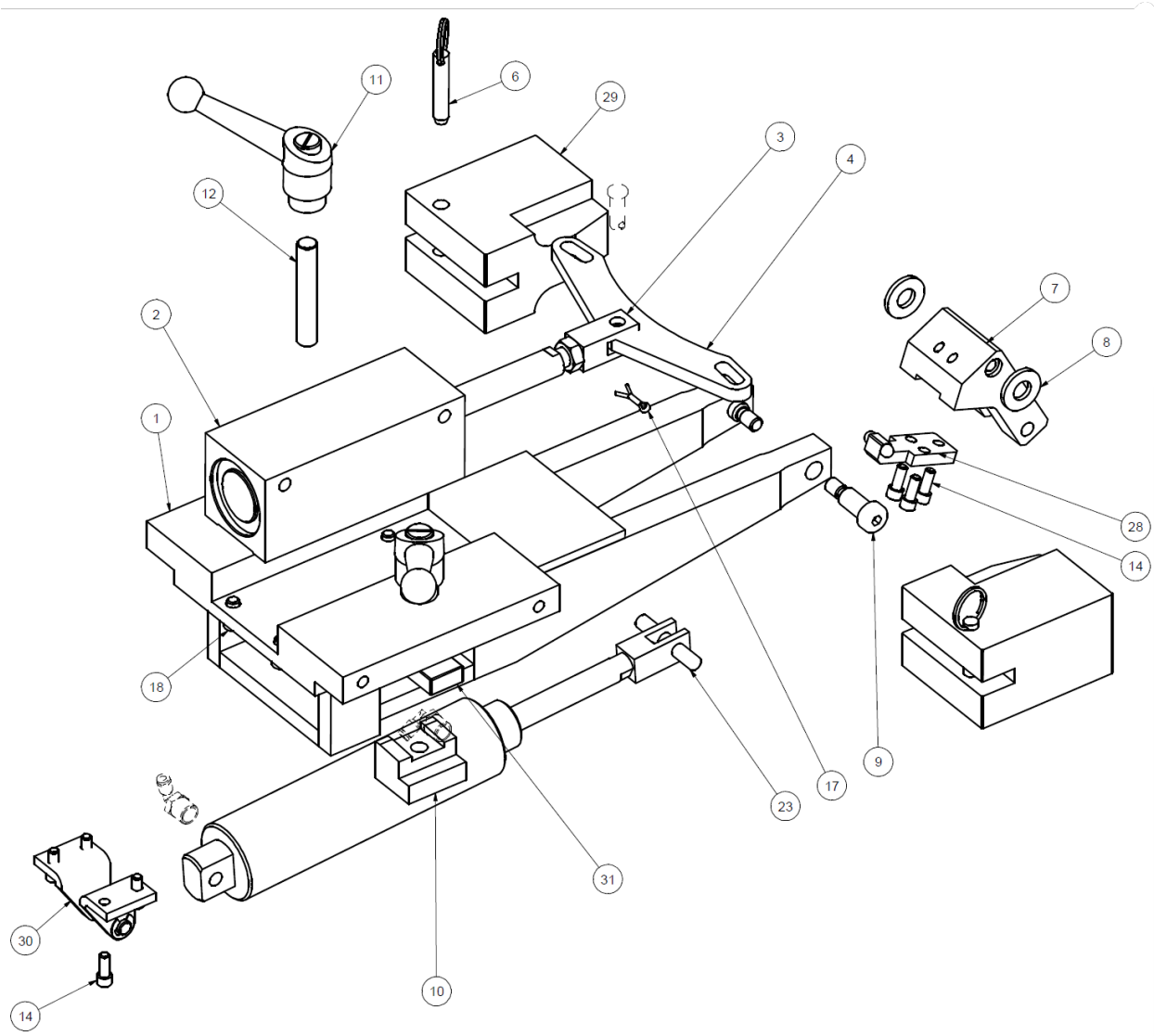



CONROD CARRIAGE ASSEMBLY			
ITEM	QTY	PART NUMBER	DESCRIPTION
1	1	650-3-67	CARRIAGE, MACHINING
2	1	650-3-45D	WEDGE CYLINDER
3	2	650-3-45L	CLEVIS
4	1	650-3-48J	LINKAGE, WEDGE
6	2	650-3-48K	RELEASE PIN, CLAMP WEDGE
7	1	650-3-47D	CENTERING LEVER
8	2	100-19A	WASHER, HARDENED 17/32" I.D.
9	2	650-4-45	SOCKET HEAD SHOULDER SCREW 1/2" X 1"
10	2	650-3-48	CLAMP SHOE
11	2	514-2-39	HANDLE
12	2	514-4-5B	STUD
14	7	MF-13	SOCKET HEAD CAPSCREW 1/4-20 X 5/8"
15	1	MF-172	HEX NUT 1/2-20
17	1	MF-231	PIN, COTTER, 1/16" DIA X 3/4"
18	4	MF-21A	SOCKET HEAD CAPSCREW 5/16-18 X 1/2"
23	1	MF-212A	DOWEL PIN 3/8" X 2 1/4"
24	1	MF-60	SOCKET SET SCREW, CUP POINT, 1/4-20 X 1/4"
28	1	650-3-47H	CENTERING BLOCK – SMALL CONROD FIXTURE ASSEMBLY
29	2	650-3-48T	WEDGE CLAMP, SPECIAL SMALL CONROD FIXTURE
30	1	5531B	LOWER CYLINDER MOUNT
31	1	650-3-48Q	CLAMP BAR, CARRIAGE, SMALL CONROD FIXTURE
32	1	650-3-45F	CENTERING CYLINDER

Conrod Clamp Assembly

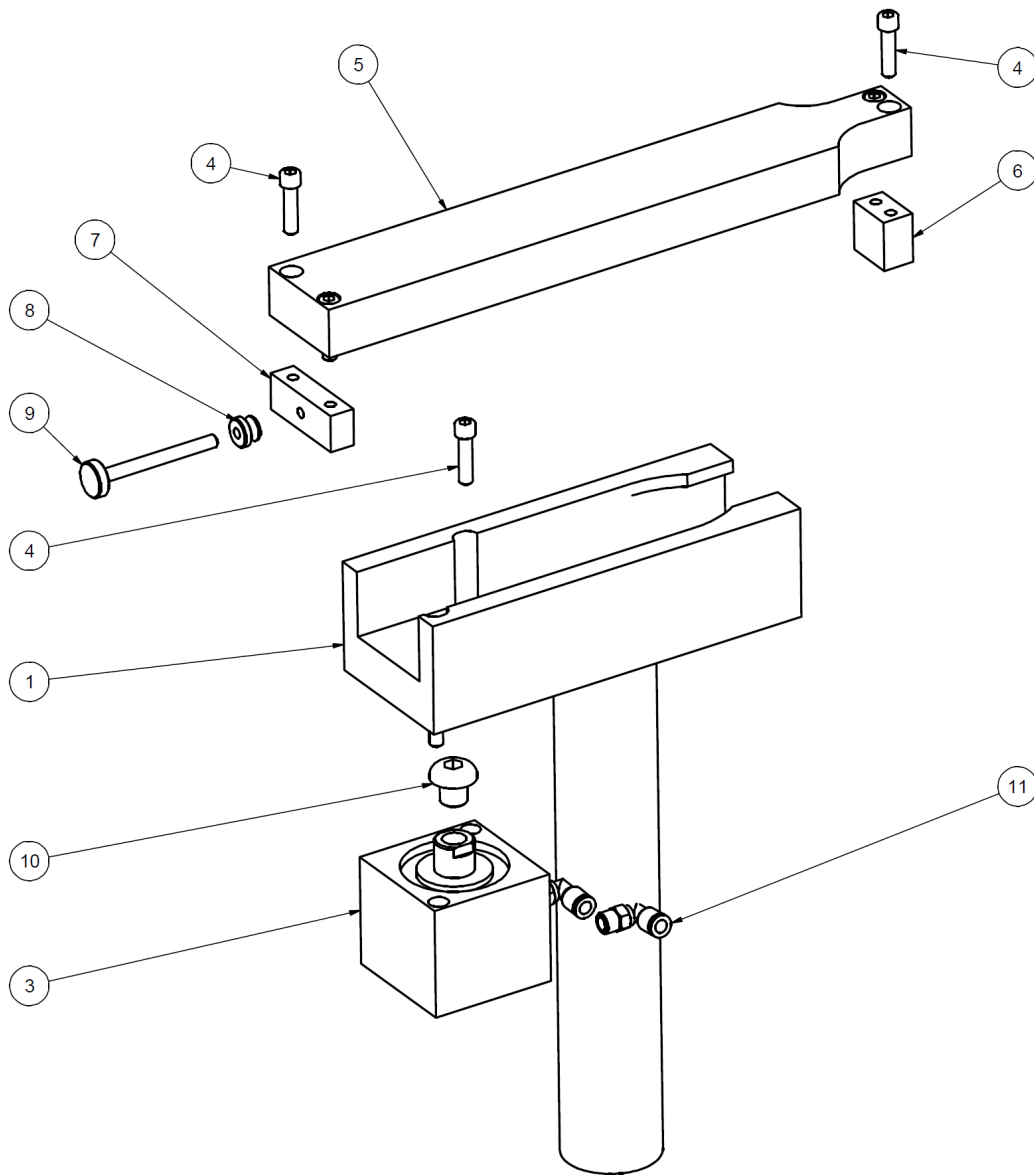

CONROD CARRIAGE ASSEMBLY			
ITEM	QTY	PART NUMBER	DESCRIPTION
1	1	650-3-49H	CLAMP LEG
2	1	502-8-52C	SPRING PLUNGER
3	1	650-3-45E	CLAMP ARM CYLINDER
4	6	MF-15	SOCKET HEAD CAPSCREW 1/4-20 X 1"
5	1	650-3-49K	CLAMP ARM
6	1	650-3-49L	CLAMP ARM EXTENSION
7	1	650-3-49N	STOP BLOCK
8	1	650-3-34J	THUMB KNOB, REID AJ-721
9	1	650-3-34S	CLAMP SCREW
10	1	650-3-61S	SOCKET BUTTON HEAD SCREW, 1/2-13 X 5/8"
11	2	-	1/8" NPT X 1/4" PTL 90 DEG FITTING

650-3-64 Heavy Duty Precision Connecting Rod Fixturing System
For large blocks, such as CAT 3500, Waukesha 7042, White Superior 825

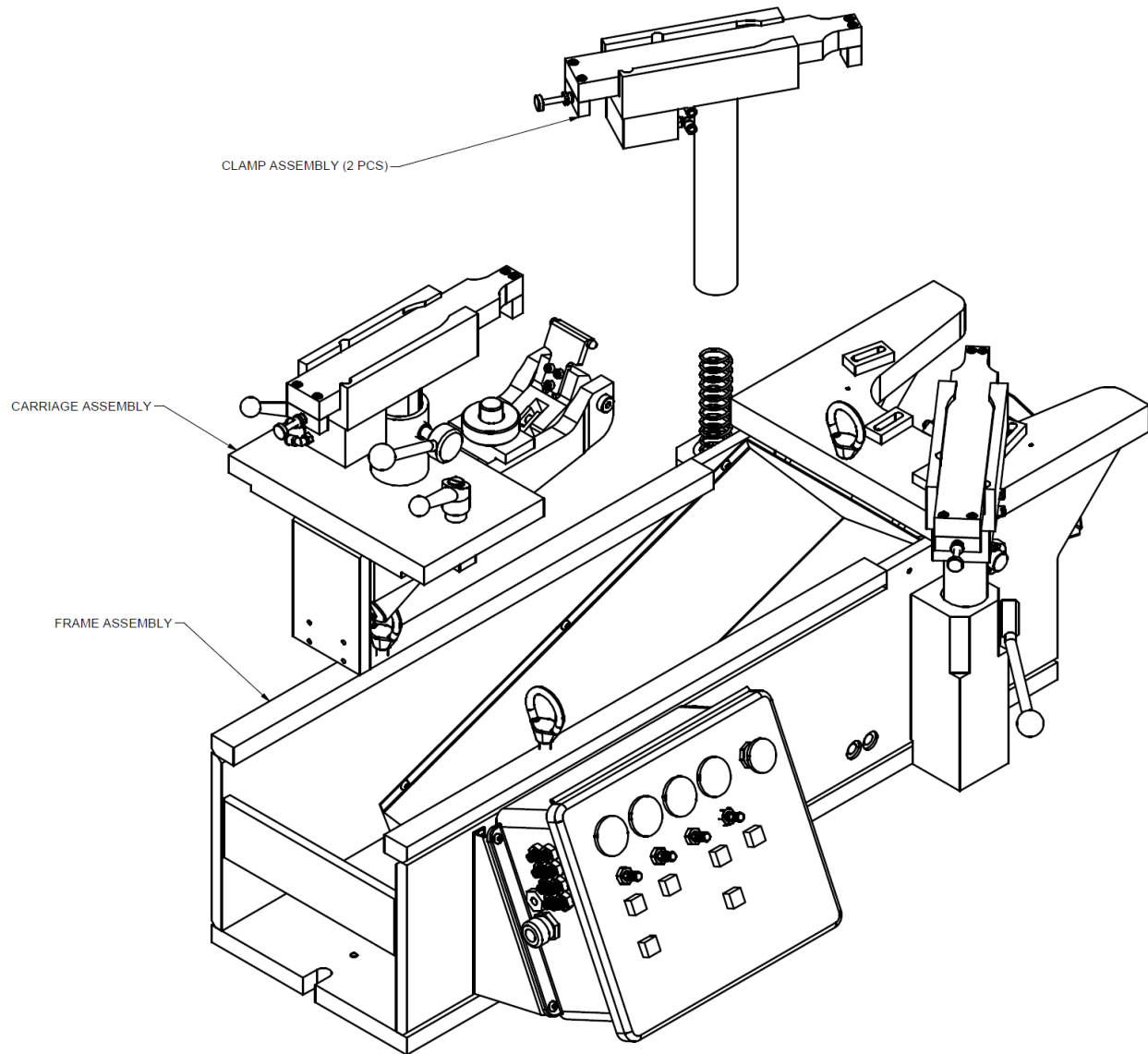

Conrod Frame Assembly

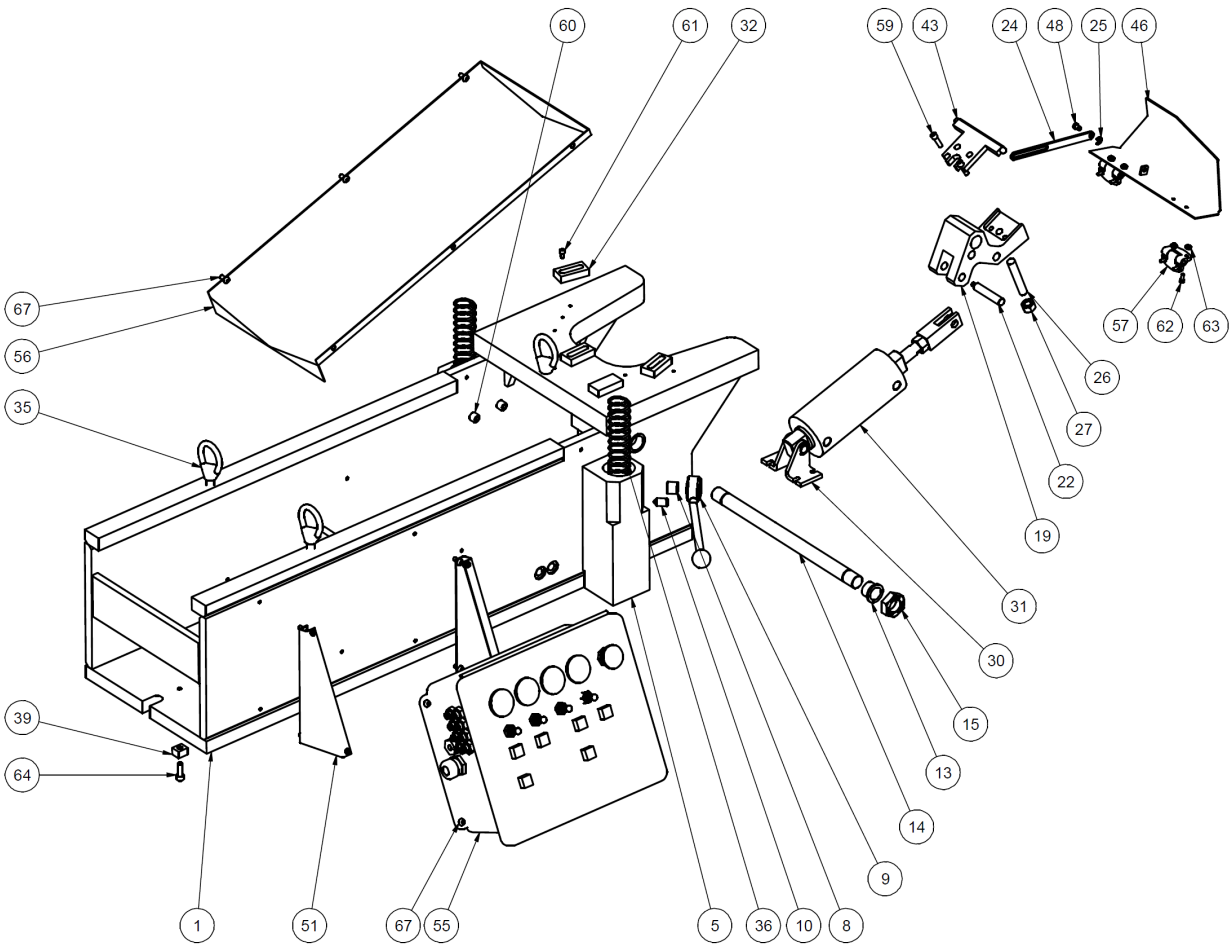



CONROD FRAME ASSEMBLY			
ITEM	QTY	PART NUMBER	DESCRIPTION
1	1	650-3-64A	MAIN FRAME (MACHINING)
5	1	650-3-49E	CLAMP BASE – RIGHT SIDE
6	1	650-3-49F	CLAMP BASE – LEFT SIDE
8	2	6310R	THREAD INSERT
9	2	6310J	CLAMP HANDLE
10	2	502-8-52C	SPRING PLUNGER
13	2	650-3-46U	FLANGE BEARING, SYMMCO SF-2832-12
14	2	650-3-64M	SHAFT-LOCATING BLOCK HEAVY DUTY CONROD FIXTURE ASS'Y
15	2	650-3-46T	LOCK NUT, REID BLN-105
19	1	650-3-64G	LOCATOR HOLDER
22	1	650-3-46K	PIVOT PIN
24	1	650-3-65G	LINKAGE ARM
25	2	650-3-46R	E-CLIP – TRUEARC #RE-25ST
26	1	650-3-47K	STOP SCREW
27	1	MF-165	HEX NUT, 1/2-13
28	1	650-3-64J	LOCATOR – 3.83" HEAVY DUTY CONROD FIXTURE ASS'Y
30	1	650-3-45H	PIVOT BRACKET, BIMBA #D-13512-A
31	1	650-3-45G	CENTERING CYLINDER, CONROD FIXTURE ASS'Y
32	3	650-3-48L	SUPPORT PARALLEL
33	1	650-3-48M	SUPPORT PARALLEL, +.002
35	3	502-3-13	LIFT EYE
36	2	650-3-49M	SPRING
37	2	650-3-49G	CLAMP LEG SPACER TUBE
39	2	650-3-9	KEY
43	1	650-3-64H	LOCATOR – 4.95" HEAVY DUTY CONROD FIXTURE
46	1	650-3-65F	DUST COVER
48	1	650-3-46H	LINKAGE PIN
51	2	650-3-65D	BRACKET, CONTROL BOX, CON-ROD FIXTURE
54	4	650-3-47W	RIVET NUT, REID ALC-47850
55	1	650-3-47T	CONTROL BOX, CONROD FIXTURE ASS'Y
56	1	650-3-65E	CHIP CHUTE
57	2	650-3-46S	HINGE, LOCATOR COVER CONROD FIXTURE ASS'Y
58	1	MF-162	HEX NUT #10-24
59	6	MF-15	SOCKET HEAD CAPSCREW 1/4-20 X 1"
60	8	MF-32	SOCKET HEAD CAPSCREW 3/8-16 X 1 1/4"
61	3	MF-78	SOCKET HEAD CAPSCREW #10-24 X 3/8"
62	8	MF-3D	SOCKET HEAD CAPSCREW #8-32 X 3/8"
63	3	MF-160	HEX NUT #8-32
64	2	MF-21C	SOCKET HEAD CAPSCREW 5/16-18 X 7/8"
66	2	MF-59	SOCKET SET SCREW, FLAT POINT, 1/4-20 X 3/8"
67	14	MF-90	SOCKET BUTTON HEAD SCREW 1/4-20 X 1/2"

Conrod Carriage Assembly

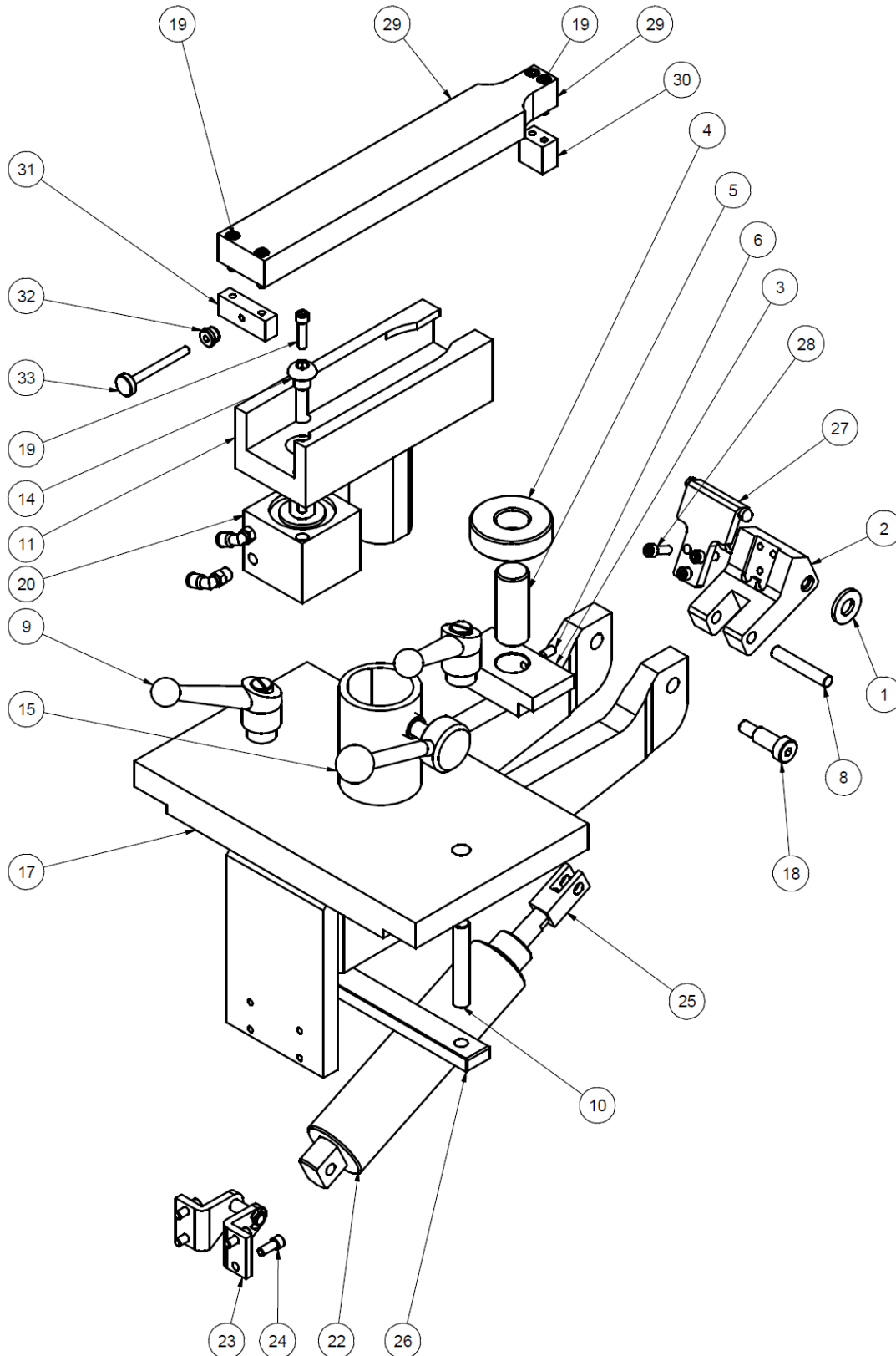



CONROD CARRIAGE ASSEMBLY			
ITEM	QTY	PART NUMBER	DESCRIPTION
1	2	100-19A	WASHER, HARDENED, 17/32" I.D.
2	1	650-3-47D	CENTERING LEVER
3	1	650-3-65A	JACK BODY
4	1	650-3-65B	JACKING NUT
5	1	650-3-65C	JACKING SCREW
6	1	MF-61	SOCKET SET SCREW, CUP POINT, 1/4-20 X 1/2"
7	1	MF-59	SOCKET SET SCREW, CUP POINT, 1/4-20 X 3/8"
8	1	MF-212A	DOWEL PIN, 3/8" X 2 1/4"
9	2	514-2-39	HANDLE
10	2	514-4-5B	STUD
11	1	650-3-64F	SHORT CLAMP ARM
14	1	650-3-61S	SOCKET BUTTON HEAD SCREW 1/2-13 X 5/8"
15	1	6310J	CLAMP HANDLE
16	1	6310R	THREAD INSERT
17	1	650-3-64C	CARRIAGE
18	2	650-4-18A	SHOULDER SCREW, 1/2" X 1"
19	6	MF-15	SOCKET HEAD CAPSCREW, 1/4-20 X 1"
20	1	650-3-45E	CLAMP ARM CYLINDER
22	1	650-3-45F	CENTERING CYLINDER
23	1	5531B	LOWER CYLINDER MOUNT
24	4	MF-82A	SOCKET HEAD CAPSCREW 1/4-20 X 5/8"
25	1	650-3-45L	CLEVIS
26	1	650-3-48R	CLAMP BAR, CARRIAGE, LARGE CONROD FIXTURE
27	1	650-3-64L	CENTERING BLOCK – 2.68 HEAVY DUTY CONROD FIXTURE ASS'Y
28	3	MF-14	SOCKET HEAD CAPSCREW 1/4-20 X 3/4"
29	1	650-3-49K	CLAMP ARM
30	1	650-3-49L	CLAMP ARM EXTENSION
31	1	650-3-49N	STOP BLOCK
32	1	650-3-34J	THUMBKNOB – REID AJ-721
33	1	350-3-34S	CLAMP SCREW

Conrod Clamp Assembly

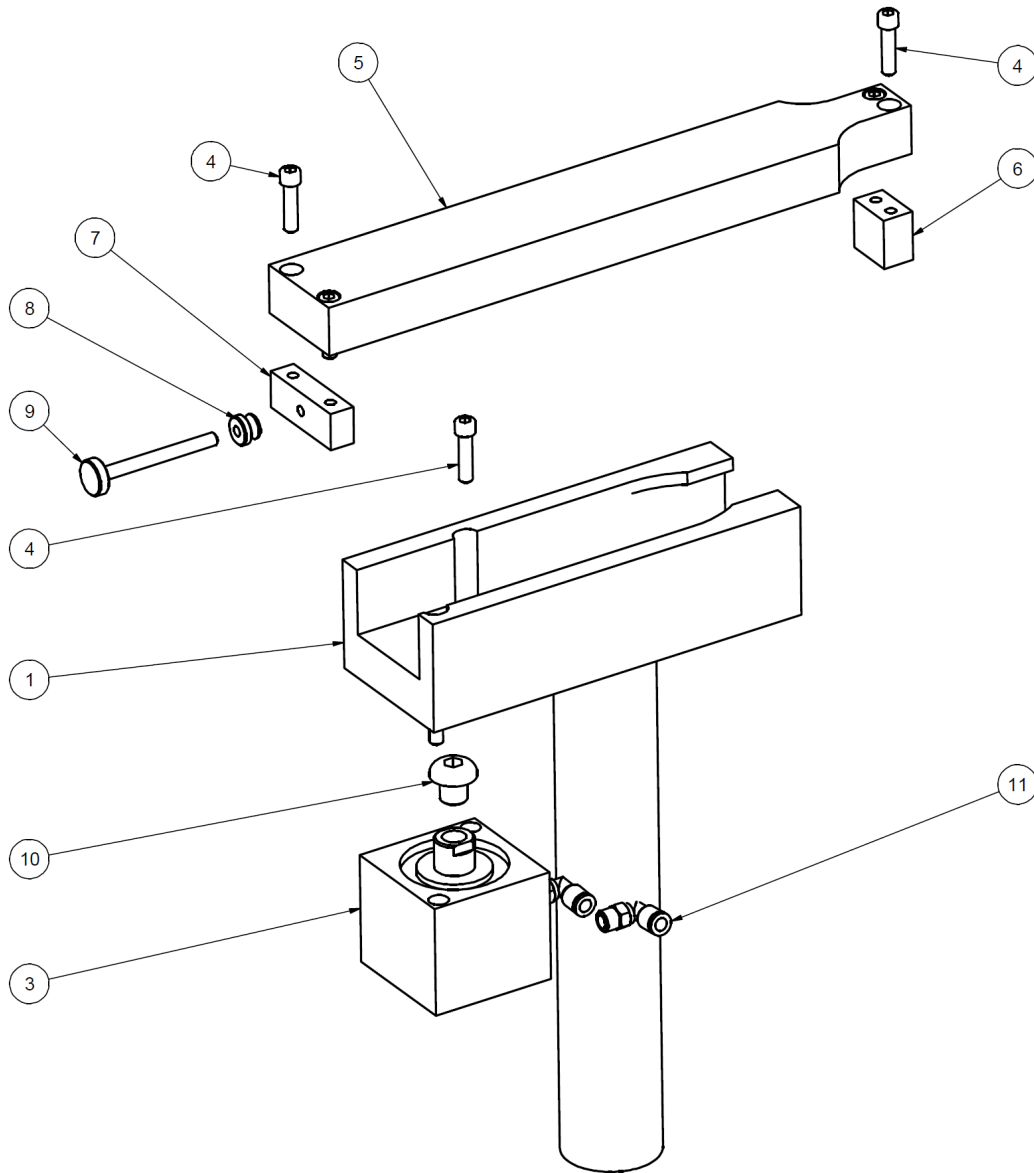

CONROD CARRIAGE ASSEMBLY			
ITEM	QTY	PART NUMBER	DESCRIPTION
1	1	650-3-49H	CLAMP LEG
2	1	502-8-52C	SPRING PLUNGER
3	1	650-3-45E	CLAMP ARM CYLINDER
4	6	MF-15	SOCKET HEAD CAPSCREW 1/4-20 X 1"
5	1	650-3-49K	CLAMP ARM
6	1	650-3-49L	CLAMP ARM EXTENSION
7	1	650-3-49N	STOP BLOCK
8	1	650-3-34J	THUMB KNOB, REID AJ-721
9	1	650-3-34S	CLAMP SCREW
10	1	650-3-61S	SOCKET BUTTON HEAD SCREW, 1/2-13 X 5/8"
11	2	-	1/8" NPT X 1/4" PTL 90 DEG FITTING

690-3-70 Automatic 4th Axis Block Roll Over Fixture

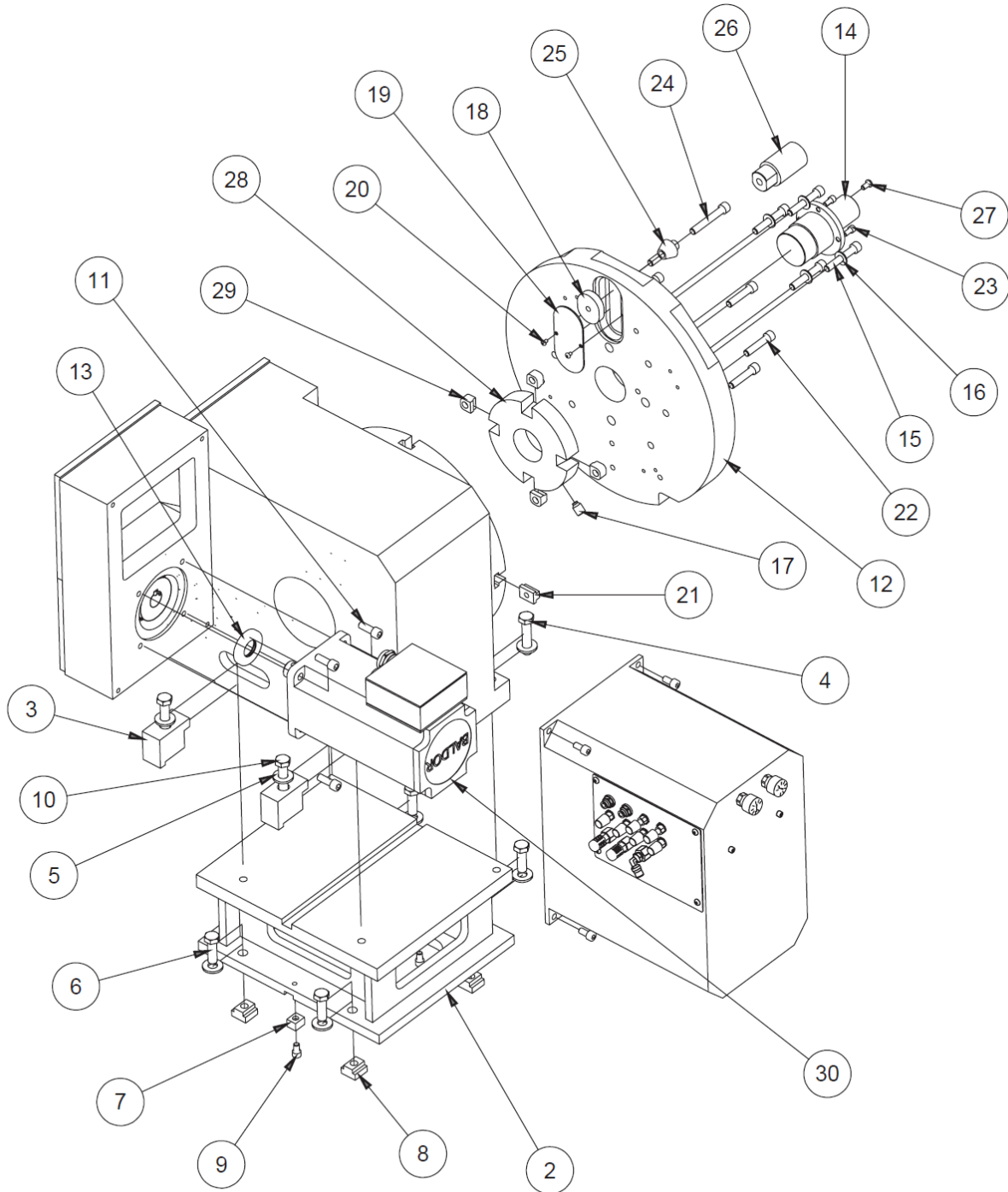

690-3-63
HEADSTOCK ASSEMBLY



690-3-63 4TH AXIS FIXTURE HEADSTOCK ASSEMBLY			
ITEM	QTY	PART NUMBER	DESCRIPTION
1	1	690-3-96	INDEXER, 4 TH AXIS FIXTURE
2	1	650-3-85C	RISER, MACHINING – 4 TH AXIS FIXTURE
3	2	650-3-85D	CLAMP, INDEXER – 4 TH AXIS FIXTURE
4	2	MF-49A	HEX HEAD CAPSCREW 1/2-13 X 2 1/4"
5	8	100-19A	HARDENED WASHER 17/32"
6	4	MF-137A	HEX HEAD CAPSCREW 1/2-13 X 1 1/2"
7	2	650-3-9	KEY
8	4	650-3-10	TN-5 T-NUT
9	2	MF-21A	SOCKET HEAD CAPSCREW 5/16-18 X 1/2"
10	2	MF-150C	HEX HEAD CAPSCREW 1/2-13 X 2 3/4"
11	4	MF-143	SOCKET HEAD CAPSCREW 3/8-16 X 1"
12	1	650-3-62B	FACEPLATE – AUTO PERFORMANCE FIXTURE
13	1	6481H	SEAL
14	1	650-3-62H	PINION, FACEPLATE – AUTO PERFORMANCE FIXTURE
15	4	MF-35	SOCKET HEAD CAPSCREW 3/8-16 X 2 1/4"
16	4	MF-178	FLAT WASHER 3/8"
17	1	6310L	SOCKET SET SCREW, BRASS TIPPED, 1/2-13 X 5/8"
18	1	650-3-62V	NUT, EXPANDING CAM LOCATOR – AUTO PERFORMANCE FIXTURE
19	1	650-3-62G	COVER, CAM LOCATOR NUT – AUTO PERFORMANCE FIXTURE
20	2	MF-86	SOCKET BUTTON HEAD SCREW #8-32 X 1/4"
21	6	650-3-61P	T-NUT, FACEPLATE – AUTO PERFORMANCE FIXTURE
22	6	MF-33A	SOCKET HEAD CAPSCREW 3/8-16 X 1 3/4"
23	4	MF-12	SOCKET HEAD CAPSCREW 1/4-20 X 1/2"
24	1	MF-36	SOCKET HEAD CAPSCREW 3/8-16 X 2 1/2"
25	1	650-3-70D	CONE WASHER, EXPANDING CAM LOCATOR – AUTO PERFORMANCE FIXTURE
26	1	650-3-62D	CAM LOCATION SET-UP TOOL – AUTO PERFORMANCE FIXTURE
27	1	MF-90	SOCKET BUTTON HEAD SCREW 1/4-20 X 1/2"
28	1	650-3-96A	CENTERING RING, FACEPLATE, 4 TH AXIS FIXTURE
29	4	650-3-96B	CENTERING WEDGE, FACEPLATE, 4 TH AXIS FIXTURE
30	1	9020H	MOTOR

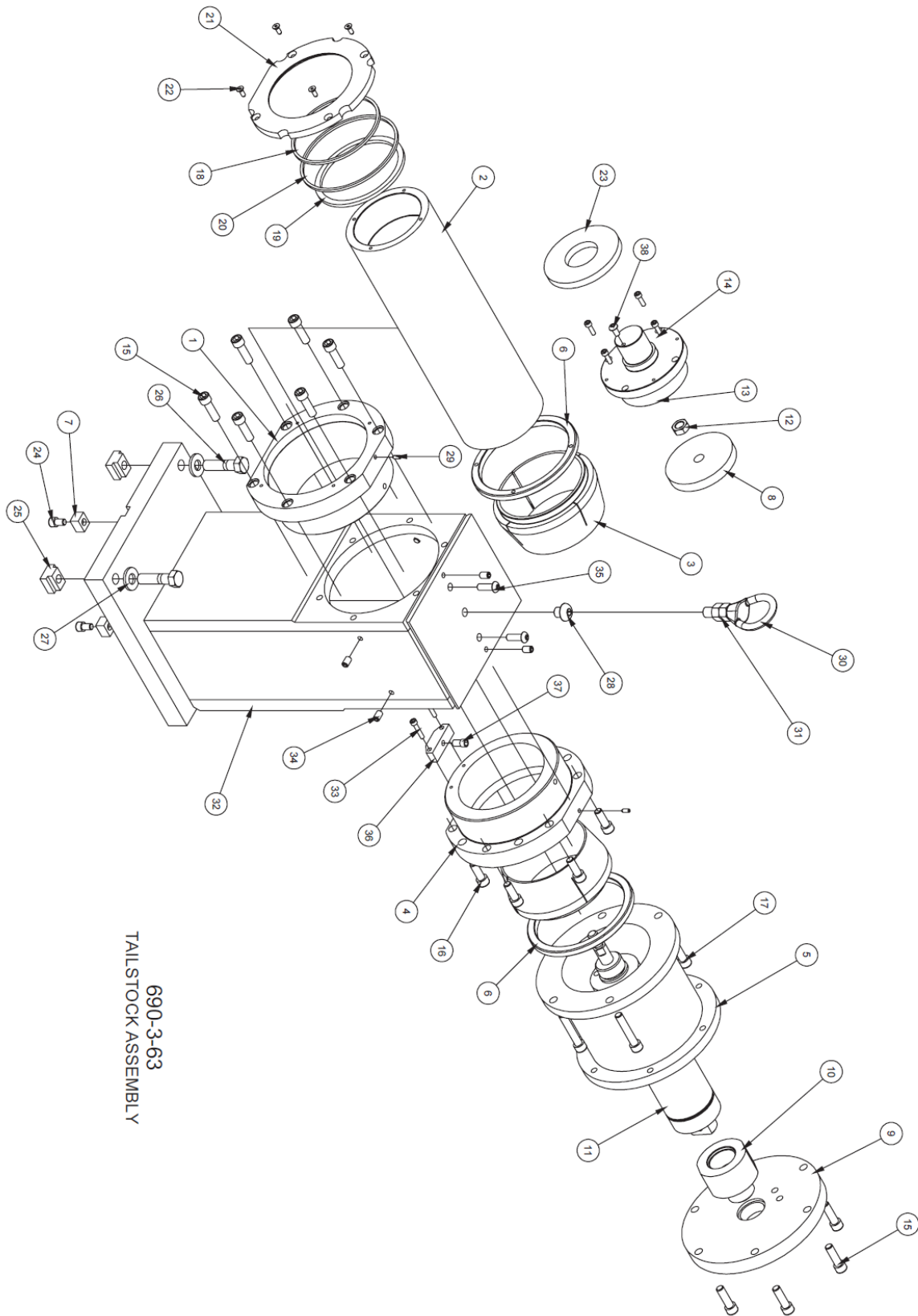

690-3-63
TAILSTOCK ASSEMBLY



690-3-63 4TH AXIS FIXTURE TAILSTOCK ASSEMBLY			
ITEM	QTY	PART NUMBER	DESCRIPTION
1	1	6225A	LOWER BEARING CARRIER
2	1	650-3-61G	PISTON TUBE, TAILSTOCK ASSEMBLY – 4 TH AXIS FIXTURE
3	2	6222B	BUSHING, TAILSTOCK SPINDLE – 4 TH AXIS FIXTURE
4	1	650-3-74	REAR BEARING CARRIER, TAILSTOCK – 4 TH AXIS FIXTURE
5	1	650-3-61C	EXTENSION, TAILSTOCK – AUTO PERFORMANCE FIXTURE
6	2	6223	OUTER SPINDLE NUT
7	2	650-3-9	KEY
8	1	650-3-61J	NOSE PLATE, TAILSTOCK – AUTO PERFORMANCE FIXTURE
9	1	650-3-61L	ENDCAP, TAILSTOCK – AUTO PERFORMANCE FIXTURE
10	1	650-3-61M	SPACER, AIR CYLINDER, TAILSTOCK – AUTO PERFORMANCE FIXTURE
11	1	650-3-61E	STROKING CYLINDER, TAILSTOCK – AUTO PERFORMANCE FIXTURE
12	1	MF-172	HEX JAM NUT 1/2-20
13	1	650-3-61H	PISTON CAP, TAILSTOCK – AUTO PERFORMANCE FIXTURE
14	4	MF-5	SOCKET HEAD CAPSCREW #10-24 X 5/8"
15	12	MF-32	SOCKET HEAD CAPSCREW 3/8-16 X 1 1/4"
16	6	MF-31	SOCKET HEAD CAPSCREW 3/8-16 X 1"
17	4	MF-34	SOCKET HEAD CAPSCREW 3/8-16 X 2"
18	1	6248	WIPER, SQUARE RING
19	1	6249	FELT OILER
20	1	6251	COMPRESSOR, FELT, SQUARE RING
21	1	6247A	RETAINER, MACHINING
22	4	MF-79	SOCKET FLAT HEAD SCREW #10-24 X 1/2"
23	1	650-3-61K	CUSHION, TAILSTOCK – AUTO PERFORMANCE FIXTURE
24	2	MF-21A	SOCKET HEAD CAPSCREW 5/16-18 X 1/2"
25	3	650-3-10	TN-5 T-NUT
26	3	MF-149C	HEX HEAD CAPSCREW 1/2-13 X 2"
27	3	100-19A	HARDENED WASHER 17/32"
28	1	650-3-61S	SOCKET BUTTON HEAD SCREW 1/2-13 X 5/8"
29	2	100-82-2B	SOCKET SET SCREW, BRASS TIPPED, #8-32 X 3/8"
30	1	502-3-13	LIFT EYE
31	2	MF-171	HEX JAM NUT 1/2-13
32	1	650-3-61X	TAILSTOCK HOUSING (MACHINING) – 4 TH AXIS FIXTURE
33	2	MF-6A	SOCKET HEAD CAPSCREW #10-24 X 1"
34	6	MF-68D	SOCKET SET SCREW, FLAT POINT, 5/16-18 X 1/2"
35	2	MF-95	SOCKET BUTTON HEAD SCREW 5/16-18 X 1"
36	1	650-3-74A	KEY BLOCK
37	1	650-3-74B	KEY BOLT
38	1	MF-90	SOCKET BUTTON HEAD SCREW 1/4-20 X 1/2"

650-3-84 Block Fixture Plates, Overhead Cam

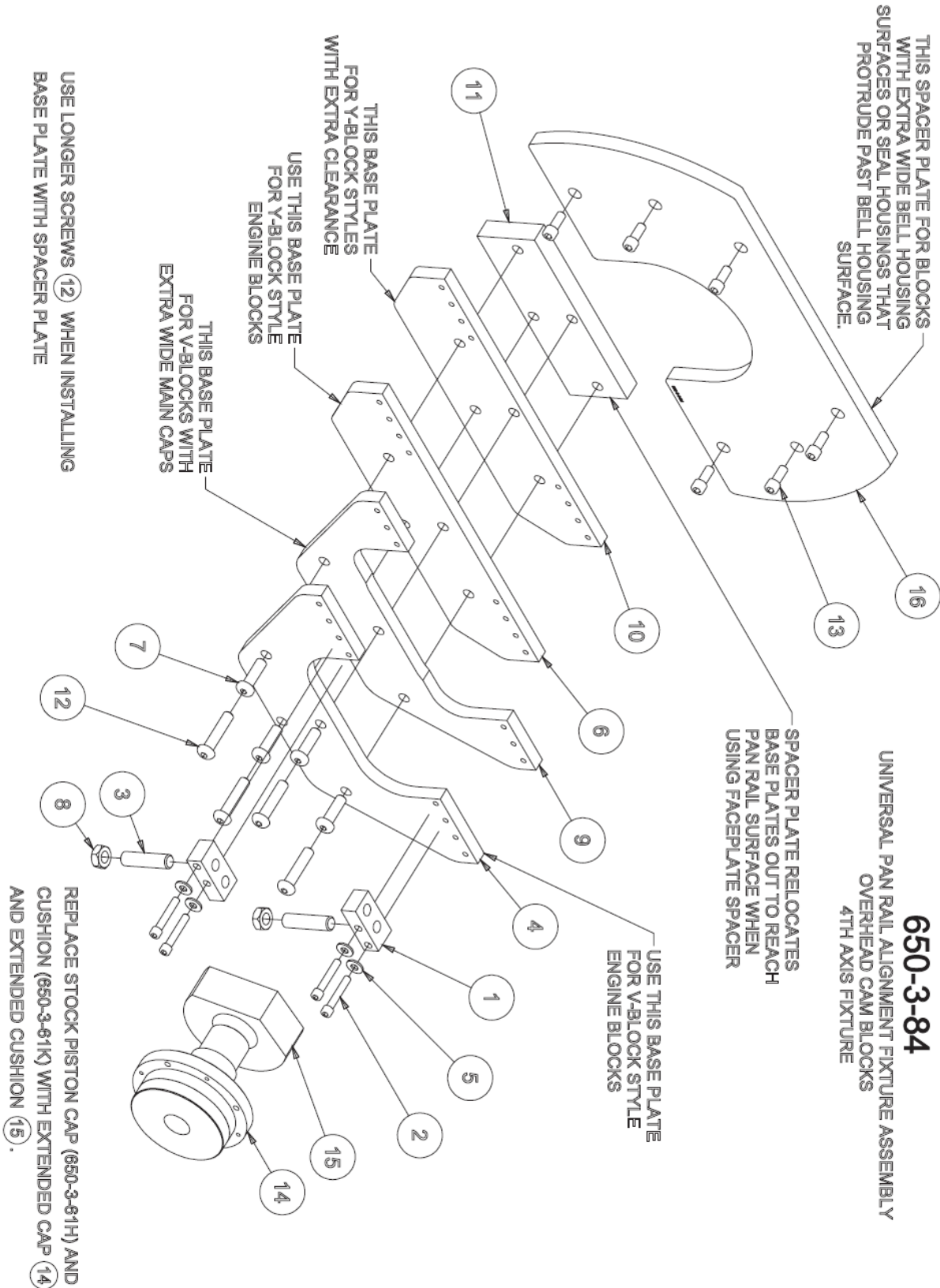

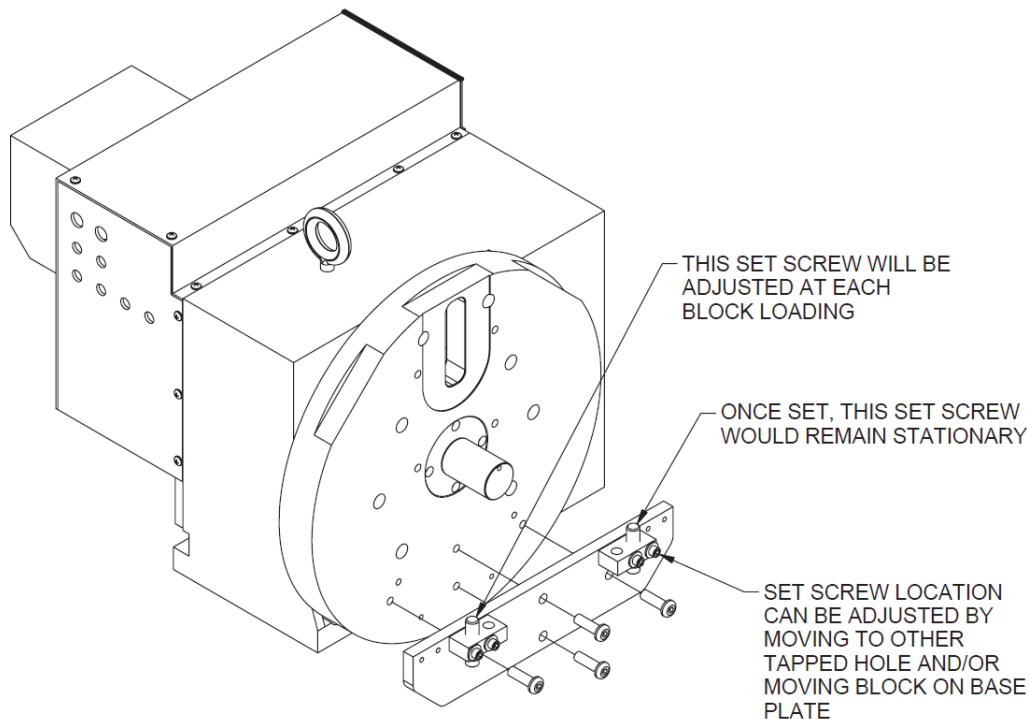

650-3-84 OVERHEAD CAM BLOCK FIXTURE
INSTALLATION AND OPERATING INSTRUCTIONS
Y-BLOCK APPLICATIONS

INSTALLATION: LOCATE THE 650-3-84E BASE PLATE ONTO THE 650-3-62B INDEXER FACEPLATE USING (4) EXISTING 3/8-16UNC TAPPED HOLES IN FACEPLATE. FASTEN BASE PLATE USING (4) MF-97C SOCKET BUTTONHEAD SCREWS.

OPERATING: THIS FIXTURE LOCATES THE PAN RAILS OF OVERHEAD CAM BLOCKS USING (2) 650-3-84D FLAT POINT SET SCREWS TO LEVEL THE BLOCK.

INSTALL THE BLOCK USING THE APPROPRIATE MAIN LOCATORS WITH THE INDEXER SET AT 0 DEGREES.

WITH THE MF-171 HEX NUTS LOOSE, ADJUST THE 650-3-84D SET SCREWS TO CONTACT THE PAN RAIL OF THE BLOCK. MULTIPLE MOUNTING HOLES ARE PROVIDED TO ALTER THE LOCATION OF THE 650-3-84C PUSH BLOCKS AND THE SET SCREWS CAN BE MOVED TO EITHER HOLE TO FIT DIFFERENT BLOCKS.

ONCE THE BLOCK IS LEVEL AND THE SET SCREWS ARE BOTH CONTACTING THE PAN RAILS, TIGHTEN THE MF-171 HEX NUTS, CHECK THE BLOCK FOR LEVEL, AND MACHINE.

TO UNLOAD THIS BLOCK AND LOAD ANOTHER BLOCK OF THE SAME STYLE:
LOOSEN THE HEX NUT AND SET SCREW NEAREST TO THE OPERATOR. REMOVE THE BLOCK AND INSTALL THE NEXT BLOCK. ROTATE THIS BLOCK TO CONTACT THE SET SCREW TO THE REAR OF THE FACEPLATE (FURTHEST FROM THE OPERATOR). ADJUST FRONT SET SCREW TO CONTACT THE BLOCK AND TIGHTEN THE HEX NUT. IT IS ADVISABLE TO CHECK THE BLOCK FOR LEVEL DUE TO THE POSSIBILITY OF VARIATION BETWEEN BLOCKS.

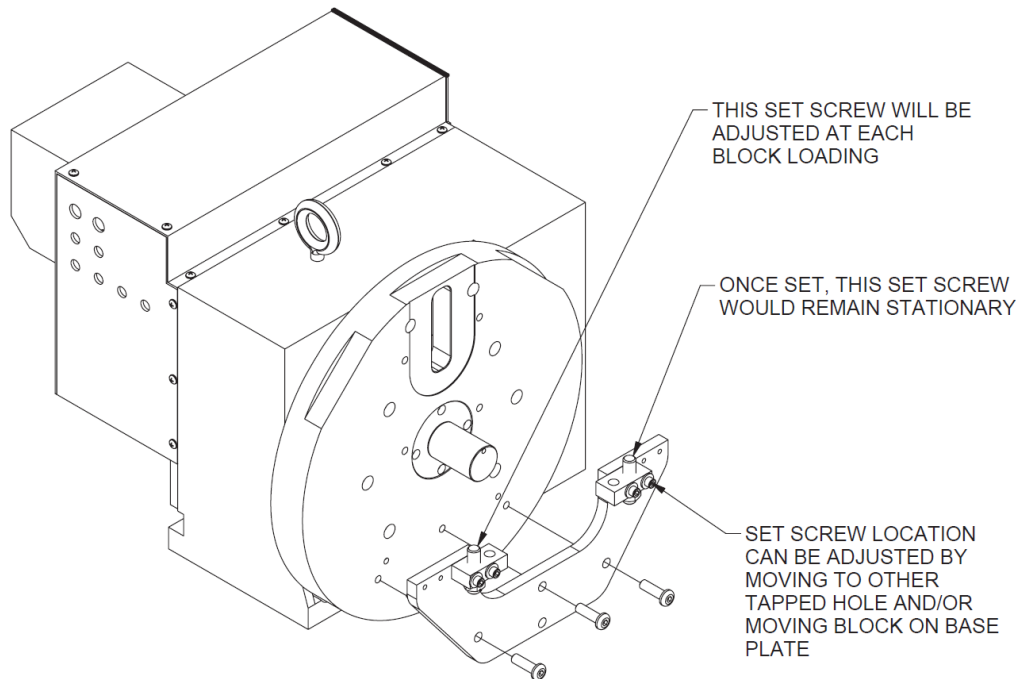

650-3-84 OVERHEAD CAM BLOCK FIXTURE
INSTALLATION AND OPERATING INSTRUCTIONS
V-BLOCK APPLICATIONS

INSTALLATION: LOCATE THE 650-3-84A BASE PLATE ONTO THE 650-3-62B INDEXER FACEPLATE USING (4) EXISTING 3/8-16UNC TAPPED HOLES IN FACEPLATE. FASTEN BASE PLATE USING (4) MF-97C SOCKET BUTTONHEAD SCREWS.

OPERATING: THIS FIXTURE LOCATES THE PAN RAILS OF V-STYLE OVERHEAD CAM BLOCK USING (2) 650-3-84D FLAT POINT SET SCREWS TO LEVEL THE BLOCK.

INSTALL THE BLOCK USING THE APPROPRIATE MAIN LOCATORS WITH THE INDEXER SET AT 0 DEGREES.

WITH THE MF-171 HEX NUTS LOOSE, ADJUST THE 650-3-84D SET SCREWS TO CONTACT THE PAN RAIL OF THE BLOCK. MULTIPLE MOUNTING HOLES ARE PROVIDED TO ALTER THE LOCATION OF THE 650-3-84C PUSH BLOCKS AND THE SET SCREWS CAN BE MOVED TO EITHER HOLE TO FIT DIFFERENT BLOCKS.

ONCE THE BLOCK IS LEVEL AND THE SET SCREWS ARE BOTH CONTACTING THE PAN RAILS, TIGHTEN THE MF-171 HEX NUTS, CHECK THE BLOCK FOR LEVEL, AND MACHINE.

TO UNLOAD THIS BLOCK AND LOAD ANOTHER BLOCK OF THE SAME STYLE:
LOOSEN THE HEX NUT AND SET SCREW NEAREST TO THE OPERATOR. REMOVE THE BLOCK AND INSTALL THE NEXT BLOCK. ROTATE THIS BLOCK TO CONTACT THE SET SCREW TO THE REAR OF THE FACEPLATE (FURTHEST FROM THE OPERATOR). ADJUST FRONT SET SCREW TO CONTACT THE BLOCK AND TIGHTEN THE HEX NUT. IT IS ADVISABLE TO CHECK THE BLOCK FOR LEVEL DUE TO THE POSSIBILITY OF VARIATION BETWEEN BLOCKS.

11038 Optional Safety Enclosure

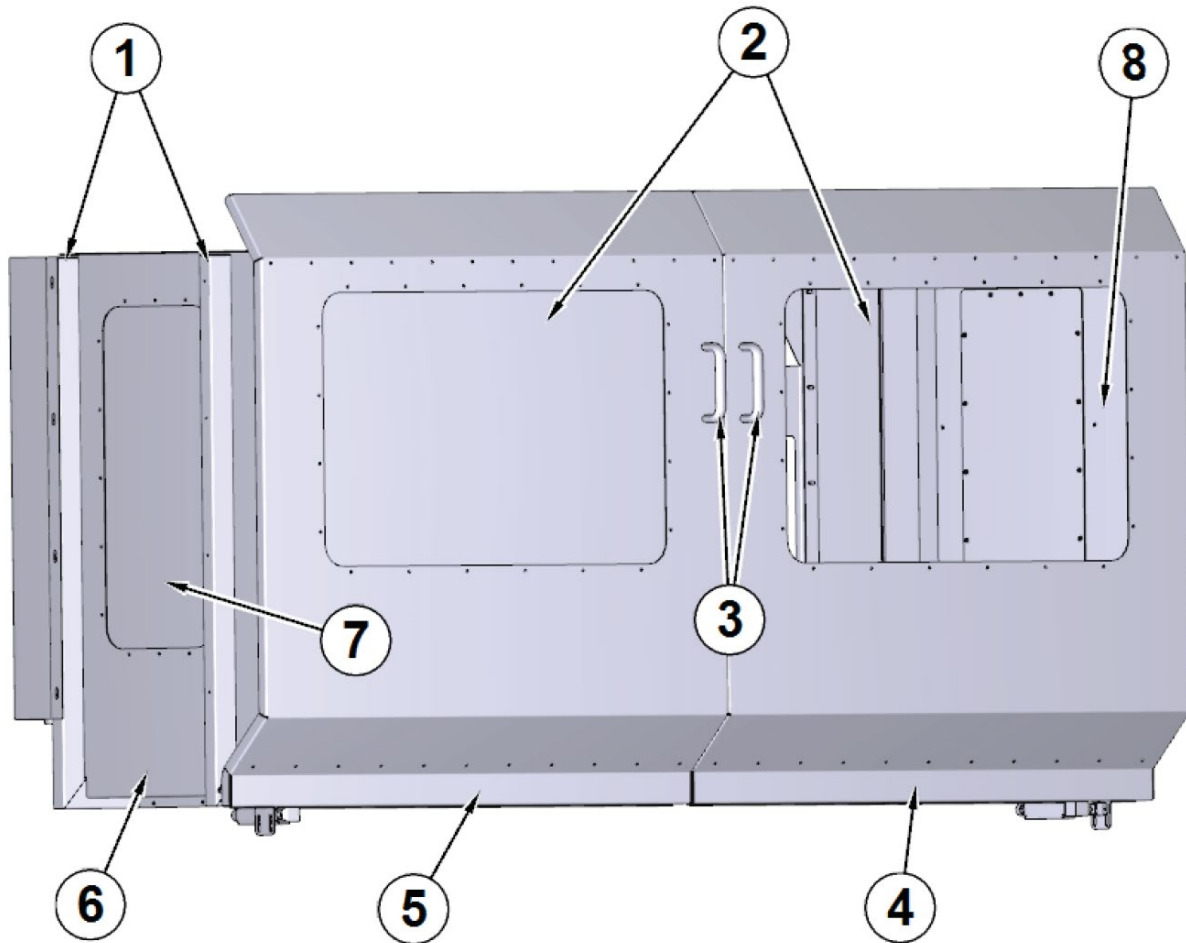

ITEM	PART NUMBER	DESCRIPTION
1	11038Q	MOUNT, FABRIC
2	11038G	WINDOW, LEXAN FRONT
3	650-1-29G	HANDLE
4	11038A	DOOR, RIGHT FRONT
5	11038B	DOOR, LEFT FRONT
6	11038N	LEFT SIDE
7	11038H	WINDOW, LEXAN SIDE
8	11038M	RIGHT SIDE

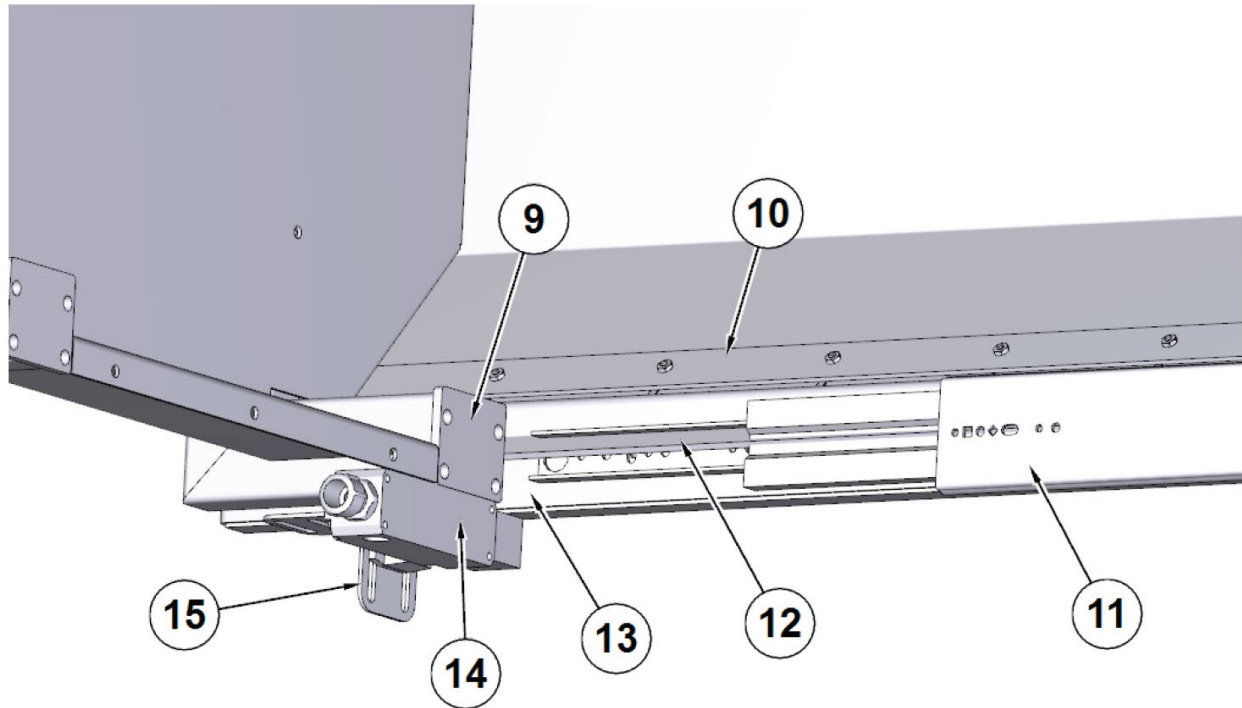

ITEM	PART NUMBER	DESCRIPTION
9	11038Q	MOUNT, FABRIC
10	11038X	PLATE, RUBBER FASTENER
11	11038F	ROLLERS, EXTENDA (PAIR)
12	11038Y	RUBBER
13	11038A	DOOR, RIGHT FRONT
14	11039M	INTERLOCK BODY
15	11039P	LOCK PLUNGER MOUNT

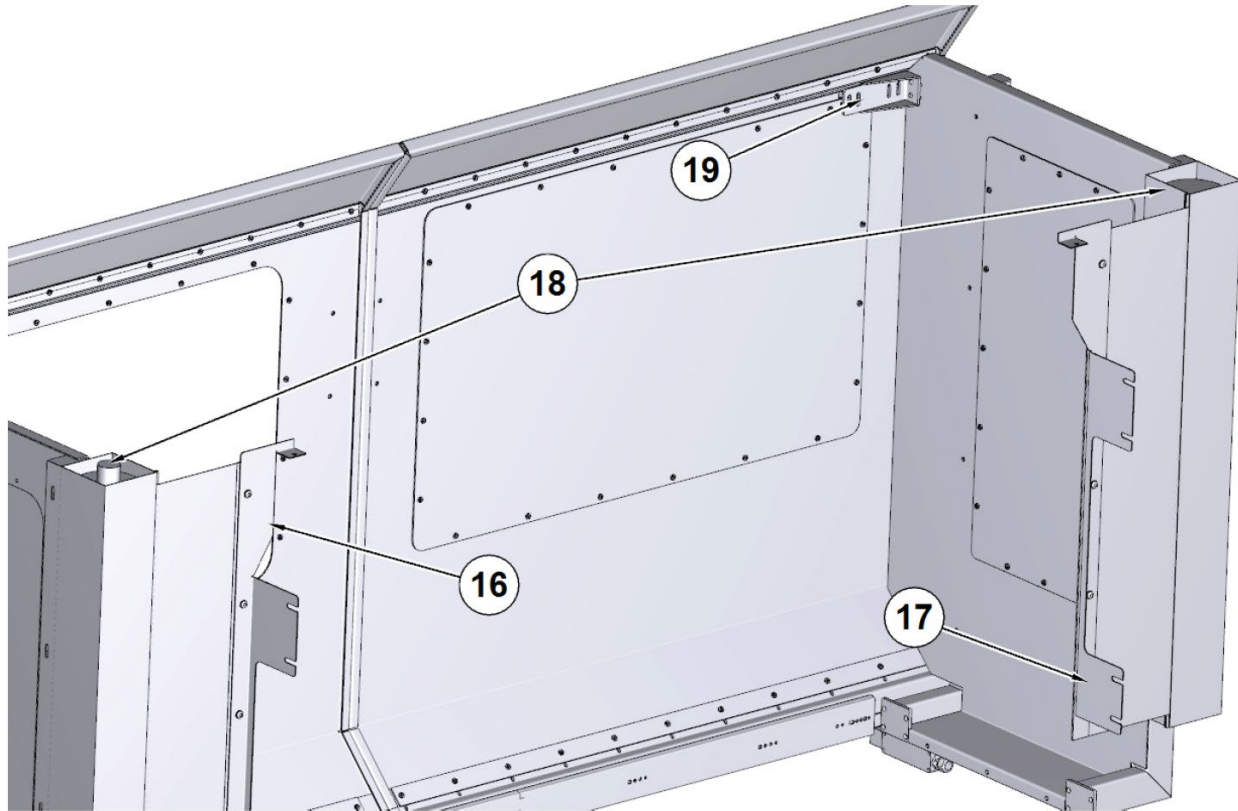

ITEM	PART NUMBER	DESCRIPTION
16	11039K	FABRIC MOUNT, RIGHT
17	11039J	FABRIC MOUNT, LEFT
18	11038L	FABRIC ROLLER
19	11038P	SUPPORT, TOP BEARING

11042 Automatic Rotary Tool Changer

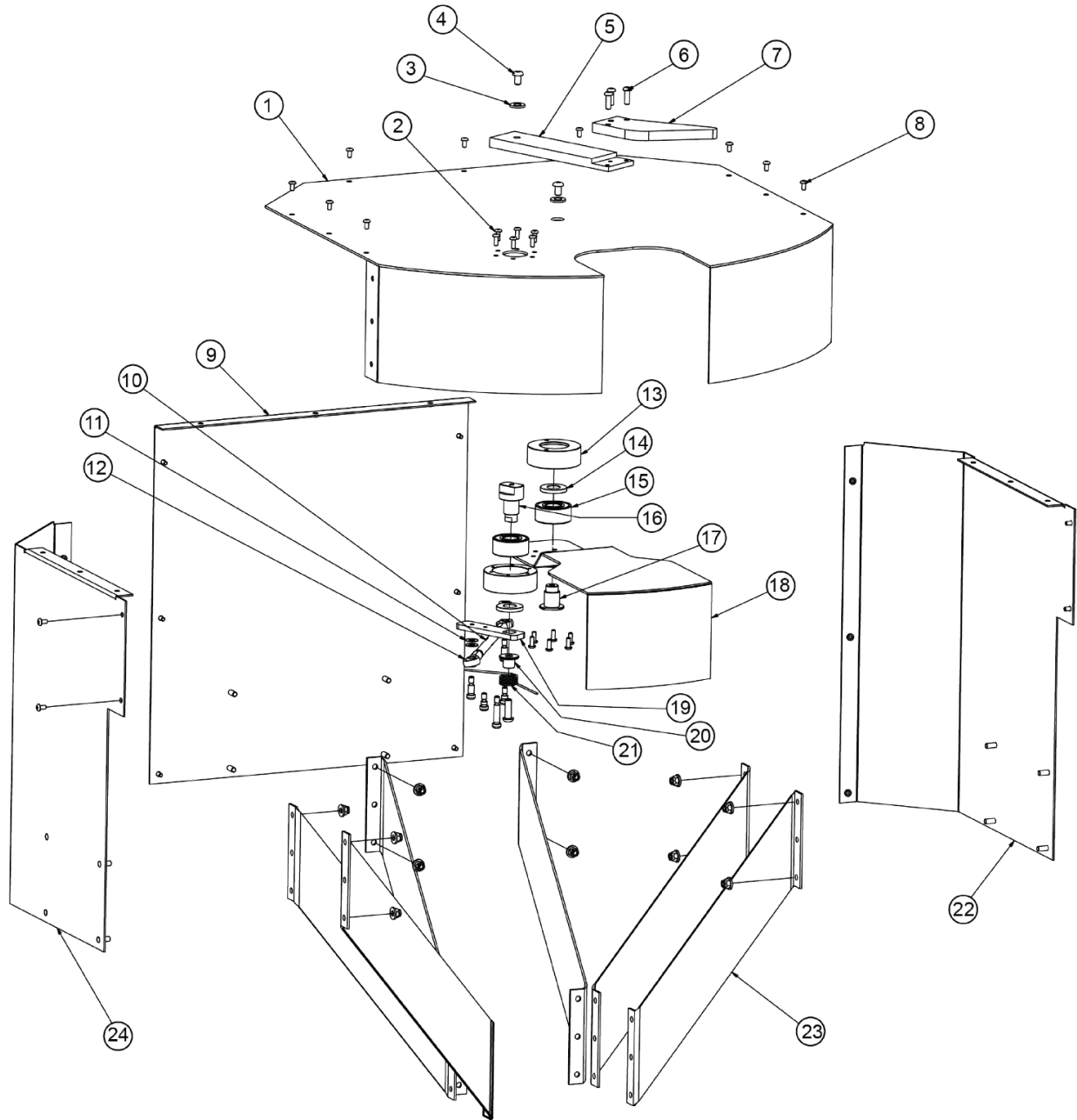



ITEM	PART NUMBER	DESCRIPTION
1	11046C	COVER, TOOL CHANGER TOP PLATE ASSEMBLY
2	MF-88A	SOCKET BUTTON HEAD SCREW #10-24 X 1/2"
3	100-28-32	WASHER, 3/32" THICK
4	MF-93A	SOCKET BUTTON HEAD SCREW 5/16-18 X 1/2"
5	11042T	DOOR, TOOL CHANGER, ACTUATOR
6	MF-92	SOCKET BUTTON HEAD SCREW 1/4-20 X 3/4"
7	11042U	TIP, ACTUATOR DOOR
8	MF-88A	SOCKET BUTTON HEAD SCREW #10-24 X 1/2"
9	11046	COVER, TOOL CHANGER BACK PANEL
10	11046G	COVER, TOOL CHANGER LINKAGE ROD
11	100-19A	WASHER, HARDENED 17/32"
12	11042V	ROD END, TOOL CHANGER COVER
13	11046H	COVER, TOOL CHANGER BEARING HOUSING
14	502-1-16	WASHER, HARDENED
15	500-74	BEARING, FEED SLEEVE
16	11046J	ACTUATOR, TOOL CHANGER PIVOT SHAFT
17	11046K	COVER, TOOL CHANGER SHAFT DOOR
18	11046E	COVER, TOOL CHANGER DOOR ASSEMBLY
19	11046F	COVER, ACTUATOR ARM
20	11046M	COVER, TOOL CHANGER SPRING SPINDLE
21	11046N	COVER, TOOL CHANGER SPRING DOOR
22	11046B	COVER, TOOL CHANGER RIGHT SIDE
23	11046L	COVER, TOOL CHANGER SUPPORT ARM
24	11046A	COVER, TOOL CHANGER LEFT

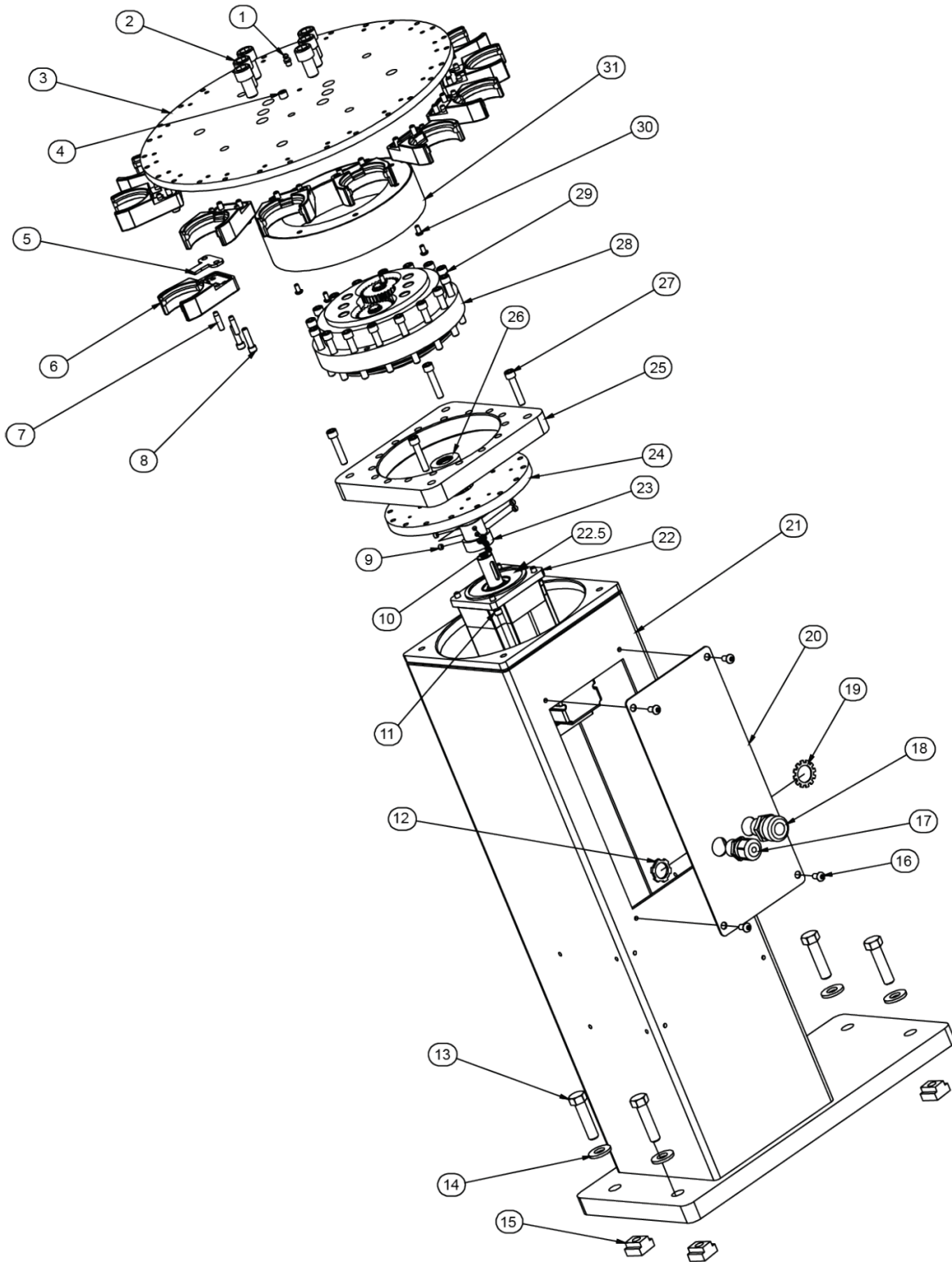



ITEM	PART NUMBER	DESCRIPTION
1	MF-189	STRAIGHT LUBE GREASE FITTING, 1/4-28
2	-	SOCKET HEAD CAPSCREW M14x2 X 25
3	11042N	PLATE, TOOL CHANGER TURRET
4	MF-233	MALE SOCKET PIPE PLUG 1/8-27
5	11042R	INDEXER, CAT 40 TOOL
6	11042Q	GRIPPER, CAT 40 TOOL
7	10360J	PIN, GRIPPER LOCATOR, HSK 80
8	MF-15	SOCKET HEAD CAPSCREW 1/4-20 X 1"
9	5506Q	SOCKET SET SCREW, FLAT POINT, 1/4-20 X 3/16"
10	5506G	SET SCREW
11	MF-14	SOCKET HEAD CAPSCREW 1/4-20 X 3/4"
12	502-2-26A	NUT
13	MF-149C	HEX HEAD CAPSCREW 1/2-13 X 2"
14	100-19A	WASHER, HARDENED 17/32"
15	650-3-10	T-NUT, 1/2-13 WITH 5/8" TABLE SLOT
16	MF-90	SOCKET BUTTON HEAD SCREW 1/4-20 X 1/2"
17	6354D	STRAIN RELIEF - 1/2" (1/8 - 1/4" DIA)
18	400-7-7	CONNECTOR, STRAIN RELIEF, 5/8"
19	502-2-26A	NUT
20	11042C	PLATE, TOOL CHANGER ACCESS
21	11042A	TOWER, TOOL CHANGER
22	9020N	MOTOR WITH BISS ENCODER
22.5	650-3-61N	SEAL
23	5506D	INPUT SHAFT - GEARBOX ASSEMBLY
24	514-13-14J	ADAPTER, MOTOR GEAR BOX
25	11042D	PLATE, TOOL CHANGER GEARBOX MOUNTING
26	650-3-61N	OIL SEAL - MOTOR
27	MF-25	SOCKET HEAD CAPSCREW 5/16-18 X 1 1/2"
28	5506C	GEARBOX ASSEMBLY
29	MF-38B	SOCKET HEAD CAPSCREW 5/16-18 X 2 1/4"
30	MF-88	SOCKET BUTTON HEAD SCREW #10-24 X 3/8"
31	514-13-14K	COVER, GEARBOX