

ROTTLER

H85AXY OPTIONAL EQUIPMENT PARTS MANUAL



PROCEDURA D'ORDINE

Contattare il rappresentante di zona Rottler per assistenza nell'ordinazione di apparecchiature opzionali, parti di ricambio o utensili.

Se non riuscite a contattare il vostro rappresentante Rottler regionale, chiamate la fabbrica al numero 253-872-7050 e chiedete di parlare con gli specialisti delle vendite di ricambi.

Tenete a portata di mano le seguenti informazioni per accelerare il processo di ordinazione:

1. Il vostro nome, la ragione sociale e il numero di contatto
2. Numero cliente
3. Se non si dispone di un codice cliente, l'indirizzo di fatturazione
4. Indirizzo di spedizione se diverso da quello di fatturazione
5. Modello e numero di serie della macchina
6. Numero di articolo e descrizione di ciò che si desidera ordinare
7. Metodo di spedizione preferito

Potete anche contattarci via e-mail con le informazioni di cui sopra. Inviare le richieste via e-mail a: parts@rottlermfg.com o intlparts@rottlermfg.com

In alcuni casi può essere richiesto di inviare una foto del pezzo ordinato se si tratta di un pezzo di ricambio o se non è presente nel database.

Se non siete sicuri del pezzo da ordinare, contattate il nostro servizio di assistenza e chiedete di parlare con uno dei nostri consulenti di assistenza. Questi vi assisteranno nel determinare il pezzo di cui avete bisogno.

È PREVISTO UN ORDINE MINIMO DI 25,00 DOLLARI.

Contenuti

Montaggio opzionale	1
514-14-60 Parti dell'attrezzatura automatica programmabile per il ribaltamento.....	1
514-7A Parti dell'attrezzatura manuale indicizzabile Roll Over.....	4
514-7-14E Tubo della linea principale di piccolo diametro da 2" (50,8 mm).....	7
502-1-30H Parti del braccio del morsetto.....	7
11115 Parallele da 2" (50 mm) X 3" (75 mm).....	9
11112C Scanalatura a T universale per carichi pesanti da 8" (203 mm) Parti parallele.....	10
11114C Scanalatura a T universale per carichi pesanti da 16" (405 mm) Parti parallele.....	12
Dispositivo per la levigatura di più camicie di cilindro (4 camicie)	14
514-11-5 Parti del dispositivo di levigatura della camicia del cilindro.....	14
514-11-6 Parti della piastra di fissaggio.....	15
514-11-7 Parti della piastra di fissaggio.....	15
514-11-4 Parti della piastra di fissaggio.....	16
Attrezzatura opzionale per refrigeranti e filtri	17
514-4-71C Refrigerante sintetico.....	17
514-4-71D Rifrattore di liquido di raffreddamento.....	17
514-2-42C Cartuccia filtrante di ricambio a doppia gradazione 50-5 Micron.....	17
Teste di affilatura di precisione Rottler, manicotti e portapietre opzionali	18
514-9 J Medium Rottler Precision 4 Stone Holder Hone Head Assembly Parts.....	18
514-10 Parti del portasassi serie -13.....	20
Tabella delle dimensioni delle pietre per affilatura media.....	20
514-9Q Grande Rottler Precision Heavy Duty 6 Stone Holder Hone Head Assembly Parts.....	22
514-9S Grande Rottler Precision Heavy Duty 6 Stone Holder Hone Head Assembly Parts.....	24
514-9-4 E Parti del gruppo manicotto.....	26
514-9-4 F Parti del gruppo manicotto.....	26
514-9-4 G Parti del gruppo manicotto.....	27
514-9-31 Parti dei portapietre della serie.....	28
Tabella delle dimensioni della pietra della testa di Six Stone Hone.....	28
Abrasivi diamantati per teste di levigatura Rottler Precision 6 Stone Holder	31
514-9-32F Pietre diamantate, grana 80.....	31
514-9-32R Pietre diamantate grana 80.....	31
514-9-32W Pietre diamantate, grana 140/170.....	31
514-9-32K Pietre diamantate, grana 170/200.....	31
514-9-32J Pietre diamantate, grana 270/325.....	32

514-9-32 E Pietre diamantate, grana 325/400	32
514-9-32 C Pietre diamantate, grana 500	32
514-9-32 L Pietre diamantate, grana 550.....	32
514-9-32 G Pietre diamantate, grana 600	33
514-9-33 Pietre diamantate, grana 800	33
514-9-33 C Pietre diamantate, grana 800	33
514-9-33 J Pietre diamantate, grana 1200	33
514-9-33 B Pietre diamantate, grana 270/325	34
514-9-32 D Pietre diamantate, grana 325/400	34
514-9-33 A Pietre diamantate, grana 800	34
514-9-35C Pietre CBN, grana 320	35
514-9-35D Pietre CBN, grana 400	35
514-9-35B Pietre CBN, grana 600	35
514-9-14H Spazzole, per la finitura del piano	35
514-9-14Y Spazzole, per finitura a platea	35
514-9P Grande Rottler Precision Heavy Duty 4 Stone Holder Hone Head Assembly Parts	36
514-9R Grande Rottler Precision Heavy Duty 4 Stone Holder Hone Head Assembly Parts.....	38
514-9-4 A Parti di montaggio del manicotto	40
514-9B Parti del gruppo manicotto	40
514-9-4 C Parti del gruppo manicotto	41
Parti del portasassi serie 514-9-6	41
514-9-14F Pietre diamantate, grana 80.....	44
514-9-14R Pietre diamantate, grana 80	44
514-9-21R Pietre diamantate, grana 80	44
514-9-14W Pietre diamantate, grana 140/170	44
514-9-21W Pietre diamantate, grana 140/170	44
514-9-14K Pietre diamantate, grana 170/200	45
514-9-14M Pietre diamantate, grana 170/200.....	45
514-9-21M Pietre diamantate, grana 170/200.....	45
514-9-14J Pietre diamantate, grana 270/325.....	45
514-9-14T Pietre diamantate, grana 270/325.....	45
514-9-14Z Pietre diamantate, grana 270/325.....	46
514-9-14E Pietre diamantate, grana 325/400	46
514-9-14Q Pietre diamantate, grana 325/400	46
514-9-14X Pietre diamantate, grana 325/400	46

514-9-14V Pietre diamantate, grana 500	46
514-9-14C Pietre diamantate, grana 325/400	47
514-9-14P Pietre diamantate, grana 500	47
514-9-14D Pietre diamantate, grana 325/400	47
514-9-14U Pietre diamantate, grana 500	47
514-9-14L Pietre diamantate, grana 550	47
514-9-14N Pietre diamantate, grana 550	48
514-9-14G Pietre diamantate, grana 600	48
514-9-14S Pietre diamantate, grana 600	48
514-9-21G Pietre diamantate, grana 800	48
514-9-21H Pietre diamantate, grana 1000	48
514-9-21J Pietre diamantate, grana 1200	48
514-9-35C Pietre CBN, grana 320	49
514-9-35D Pietre CBN, grana 400	49
514-9-35B Pietre CBN, grana 600	49
514-9-35E Pietre CBN, grana 500	49
514-9-14H Spazzole, per la finitura del piano	50
514-9-14Y Spazzole, per finitura a platea	50
514-9-18P Diamanti speciali con finitura rossa	51
514-9-18N Silicone Abrasivo Pietre di esposizione	51
514-9-21 Feltrini per lucidatura	51
514-9-21F Pasta di silicone	51
514-9M Testa di affilatura, parti a doppio stadio	52
110-162 R Pietre diamantate a doppio stadio	52
110-163 R Pietre diamantate a doppio stadio	52
110-163 R-01 Pietre diamantate a doppio stadio	52
110-163 R-03 Pietre diamantate a doppio stadio	53
110-164 R Pietre diamantate a doppio stadio	53
110-164 R-01 Pietre diamantate a doppio stadio	53
110-164 R-03 Pietre diamantate a doppio stadio	53
124-24 Set di spazzole, testa di affilatura a doppio stadio	54
124-25 Set di spazzole, testa di affilatura a doppio stadio	54
124-26 Set di spazzole, testa di affilatura a doppio stadio	54
514-9N Testa di affilatura, parti monostadio	55
110-171-01 Pietre diamantate a stadio singolo	56

110-171-02 Pietre diamantate a stadio singolo	56
110-171-03 Pietre diamantate a stadio singolo	56
Apparecchiatura di misura opzionale	57
201 Mitutoyo Surface Tester SurfTest 201	57
514-8-27 Gruppo scala di profondità e supporto per pietra (pollici).....	57
514-8-27F Gruppo scala di profondità e supporto per pietra (metrico).....	57
514-14-29A Fotocamera.....	58
514-14-29B Pacchetto software	58
514-9V Pin Hone Adapter Parts	59
Sistema di protezione contro l'arresto di sicurezza	61
514-14-99 Barriera luminosa laser	61

Montaggio opzionale

514-14-60 Parti del dispositivo automatico programmabile Roll Over

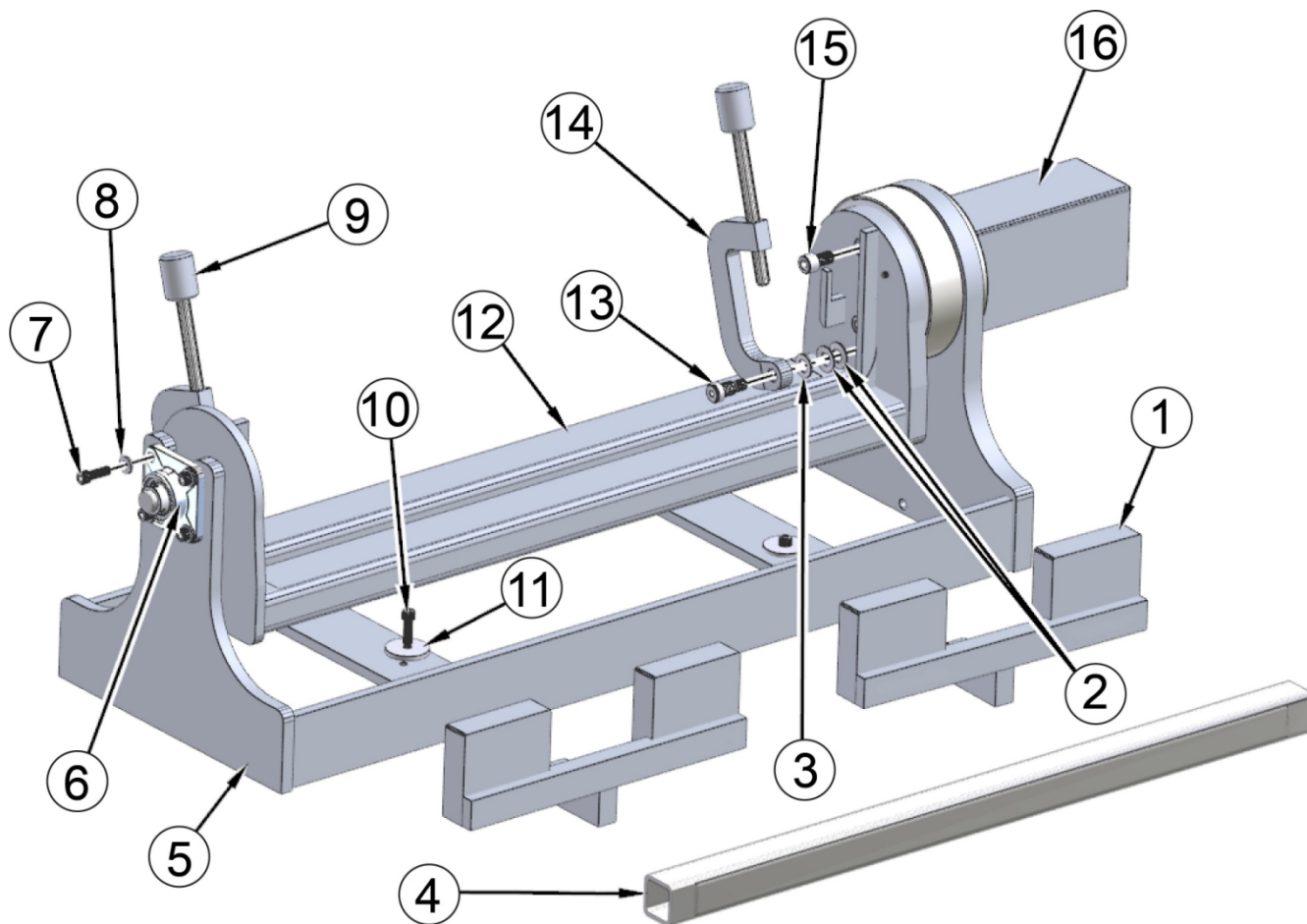

ITEM	PART #	DESCRIPTION
1	514-7-15	SUPPORT, BLOCK
2	514-7-21	WASHER, BELLEVILLE
3	514-7-20	WASHER, THRUST
4	514-7-14B	BAR, CLAMP
5	514-13-14A	BASE
6	514-13-14L	BEARING, END
7	MF-32	SOCKET HEAD CAP SCREW 3/8-16 X 1 1/4"
8	MF-179A	FLAT WASHERS 3/8"
9	7223	KNOB ASSY
10	MF-32	SOCKET HEAD CAP SCREW 3/8-16 X 1 1/4"
11	514-7-1C	WASHER, HOLD DOWN
12	514-7-14C	LOCATOR BAR, SMALL
13	MF-155	SHOULDER SCREW 3/8 X 3/4"
14	514-7-10A	ARM, CLAMP
15		M14X2 X 25 SOCKET HEAD CAP SCREW
16	514-13-14M	COVER, MOTOR

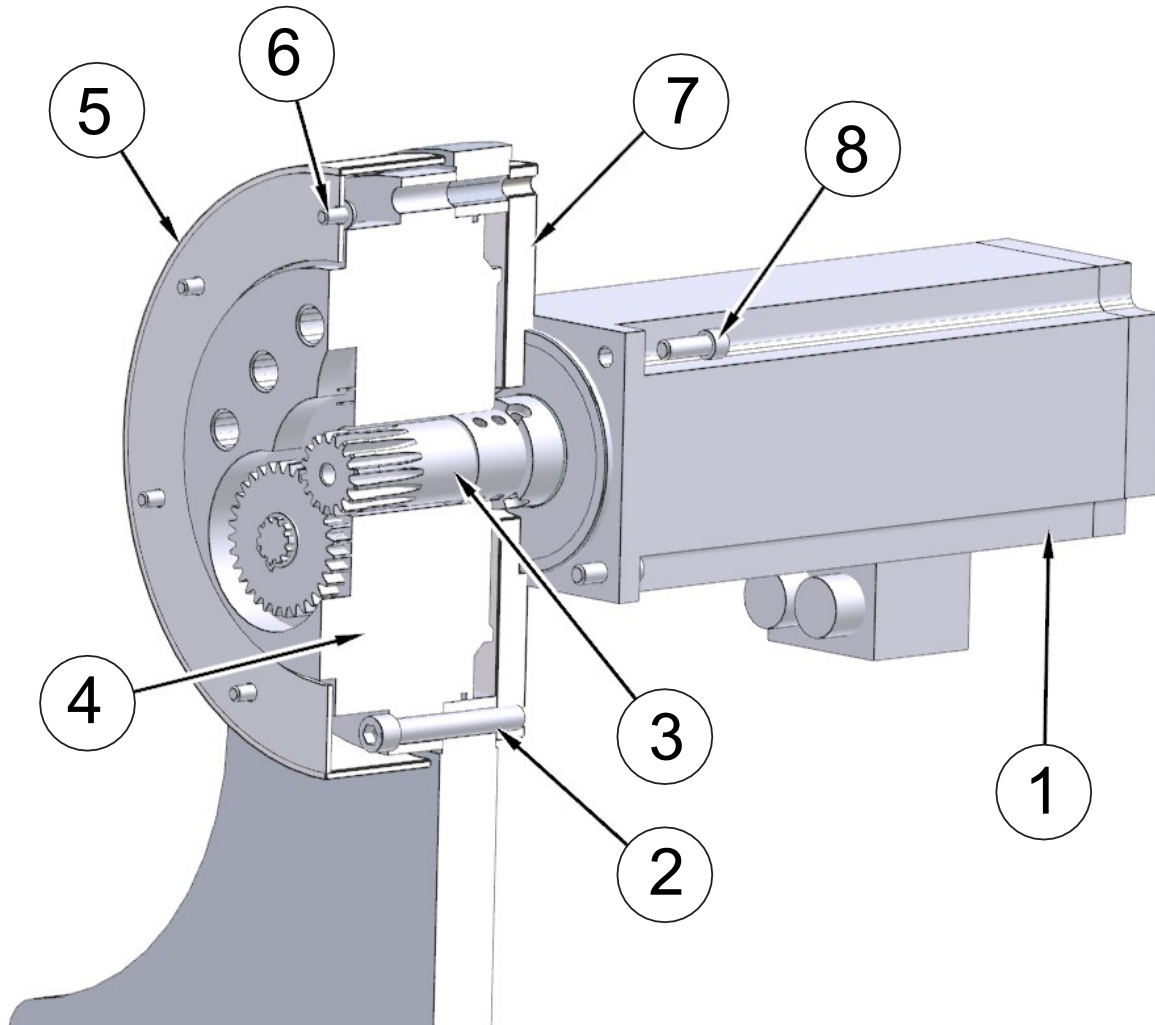

ITEM	PART #	DESCRIPTION
1	650-3-93B	SERVO MOTOR WITH BRAKE
2	MF-27C	SOCKET HEAD CAP SCREW 5/16-18 X 2 1/4"
3	5506D	INPUT SHAFT
4	5506C	GEARBOX ASSEMBLY
5	514-13-14K	COVER, GEAR BOX
6	MF-88	SOCKET BUTTON HEAD SCREW 10-24 X 3/8"
7	514-13-14J	ADAPTOR, MOTOR GEAR BOX
8	MF-14	SOCKET HEAD CAP SCREW 1/4-20 X 3/4"

514-7A Parti dell'attrezzatura manuale indicizzabile Roll Over

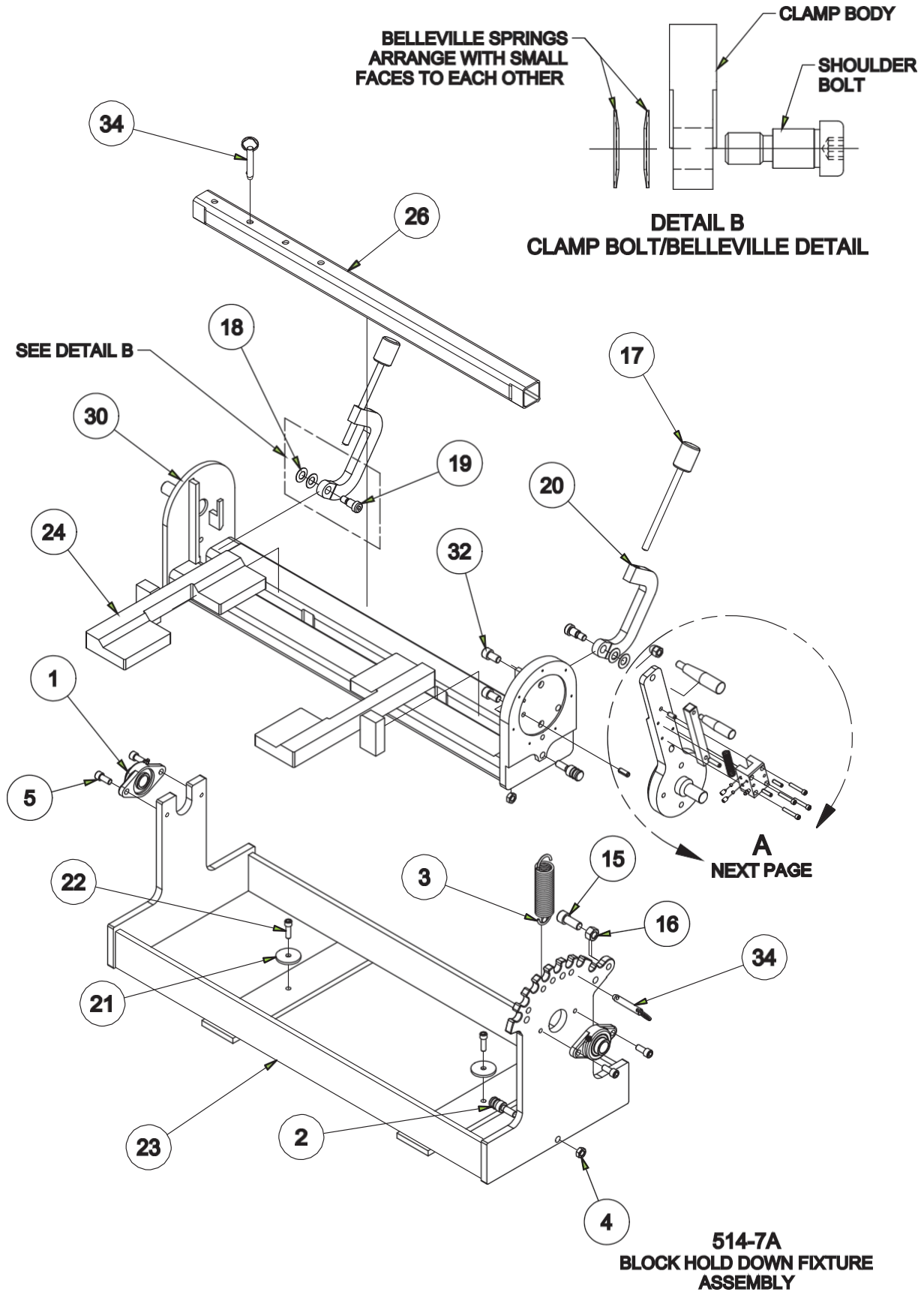

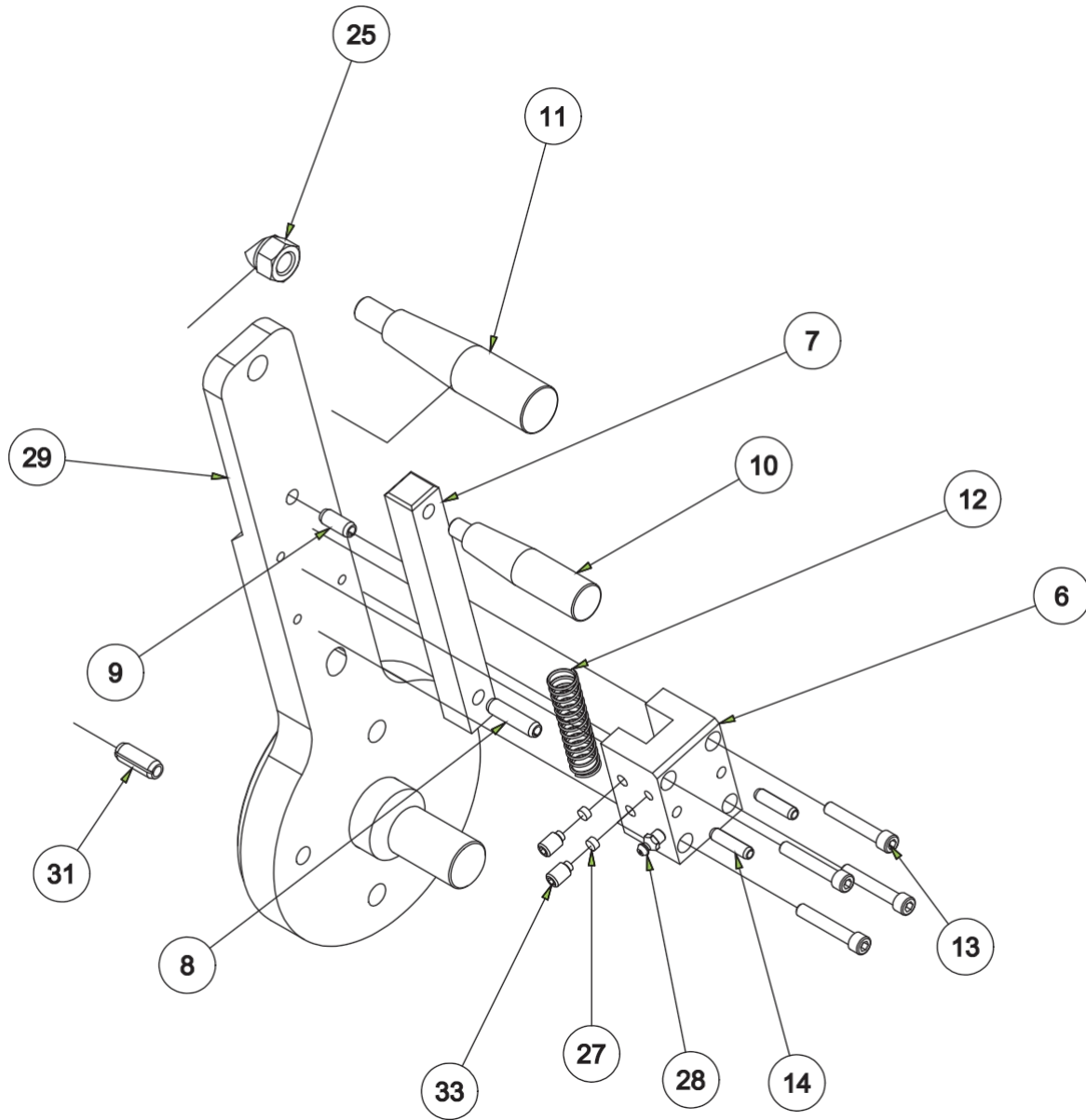

DETAIL A

514-7A BLOCK HOLD DOWN FIXTURE ASSEMBLY - HONE			
ITEM	QTY	PART NUMBER	DESCRIPTION
1	2	514-7-13	BLOCK, FLANGE, BLOCK HOLDDOWN FIXTURE
2	2	514-3-72A	PIN, SPRING RETAINER, BLOCK HOLD DOWN FIXTURE
3	1	514-3-34A	SPRING, EXTENSION - BLOCK HOLD DOWN FIXTURE
4	2	MF-165	1/2-13UNC HEX NUT
5	4	MF-39	7/16-14UNC x 1" LG. S.H.C.S.
6	1	514-3-56A	INDEX PIN SUPPORT - BLOCK HOLD DOWN FIXTURE HONE
7	1	514-7-9B	INDEX PIN - BLOCK HOLD DOWN FIXTURE - HONE
8	1	MF-227A	5/16" x 1-1/4" LG. ROLL PIN
9	1	MF-227B	5/16" x 3/4" LG. ROLL PIN
10	1	514-3-58A	HANDLE, INDEX - BLOCK HOLD DOWN FIXTURE - HONE
11	1	514-3-59B	HANDLE, PIVOT ARM - BLOCK HOLD DOWN FIXTURE & V6/V8 AIR FIXTURE
12	1	514-3-70	SPRING, HANDLE RETURN
13	4	MF-17	1/4-20UNC x 1-1/2" LG. S.H.C.S.
14	2	MF-226	1/4" x 1" LG. ROLL PIN
15	1	MF-46A	5/8-11UNC x 1-1/2" LG. S.H.C.S.
16	1	MF-166	5/8-11UNC HEX NUT
17	2	7223	CLAMP ASSEMBLY - MANUAL V6/V8 COMB. FIXTURE
18	4	514-7-21	Bellville Spring
19	2	514-7-22A	5/8 x 3/4" LG. SOCKET SHOULDER SCREW
20	2	514-7-10A	CLAMP ARM (MACHINING), BLOCK HOLD DOWN FIXTURE - HONE
21	2	514-7-1C	WASHER, HOLDDOWN - BLOCK HOLDDOWN FIXTURE - HONE
22	2	MF-32	S.H.C.S.3/8 - 16 UNC - 1 1/4
23	1	514-7-1E	MAIN FRAME REDESIGN (MACHINING)
24	2	514-7-15	SUPPORT, BLOCK - BLOCK HOLD DOWN FIXTURE
25	1	514-3-59C	1/2-13UNC ACORN NUT
26	1	514-7-14B	BAR, CLAMP - HOLD DOWN FIXTURE
27	2	514-3-56B	TERCITE PAD
28	1	MF-189	STRAIGHT GREASE FITTING
29	1	514-7-3D	MANUAL CRADLE HANDLE (MACHINING), HONE
30	1	514-13-14C	H70 - FIXTURE CRADLE MACHINING
31	1	MF-229B	3/8" x 1" LG. ROLL PIN
32	2	650-4-49	M14x2 x 25
33	2	7212C	5/16-18UNC x .50" LG. SOCKET HALF DOG SET SCREW
34	2	7210C	PIN, GUIDE ROTTLER LEVELING TABLE

514-7-14E Tubo della linea principale di piccolo diametro da 2" (50,8 mm)



502-1-30H Parti del braccio del morsetto

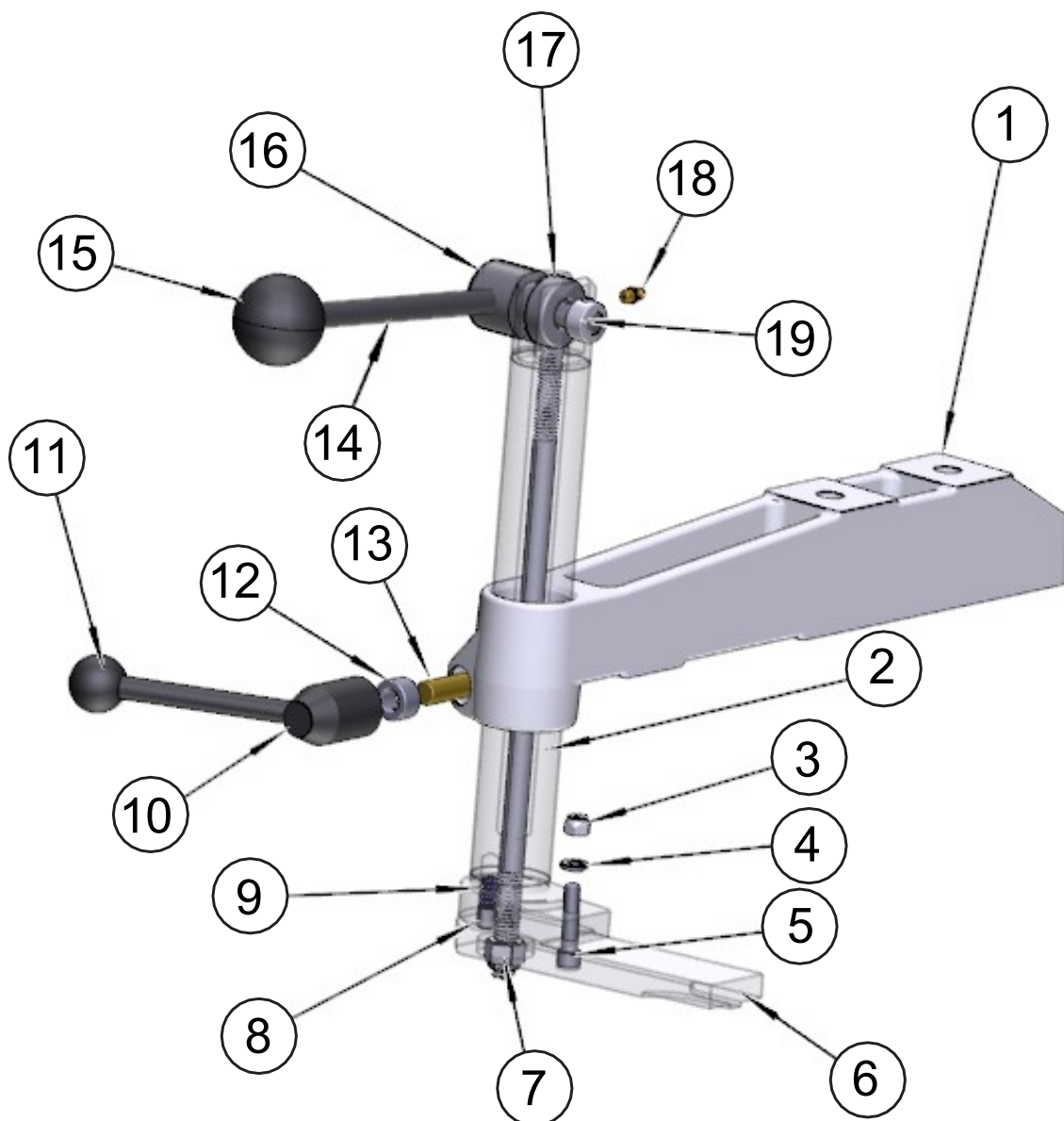

ITEM	PART #	DESCRIPTION
1	502-1-22G 502-1-22H	CLAMP ARM-LEFT CLAMP ARM-RIGHT
2	502-1-31C	LEG, CLAMP-14 1/2" LONG
3	MF-187	NYLOCK NUTS 5/16-18 NC
4	MF-184	LOCK WASHERS 5/16"
5	MF-25	SOCKET HEAD CAP SCREW 5/16-18 X 1 1/2"
6	502-1-24G	SHOE, CLAMP - HEAVY DUTY
7	502-1-25B	LOCKNUT, EYE BOLT 1/2-13NC
8	MF-211	DOWEL PIN 3/8 X 1/2"
9	500-33	SPRING, CLAMP LEG
10	514-2-39C	HANDLE,ADJUSTABLE-CLAMP STOP
11	514-2-39E	HANDLE, ADJUSTABLE CLAMP
12	7209J	COLLAR, 1/2" SHAFT
13	514-4-5B	STUD-CLAMP HANDLE
14	502-1-27	ARM, HANDLE - BLOCK CLAMP
15	502-1-28	KNOB, PLASTIC BALL - BLOCK CLAMP
16	502-1-26L 502-1-26R	CAM BODY LEFT HAND ONLY CAM BODY RIGHT HAND ONLY
17	502-1-25A	EYE BOLT ASSEMBLY
18	MF-189	1/4-28 STRAIGHT LUBE GREASE FITTING
19	502-1-29A	COLLAR (15/32 ID),CLAMP LEG

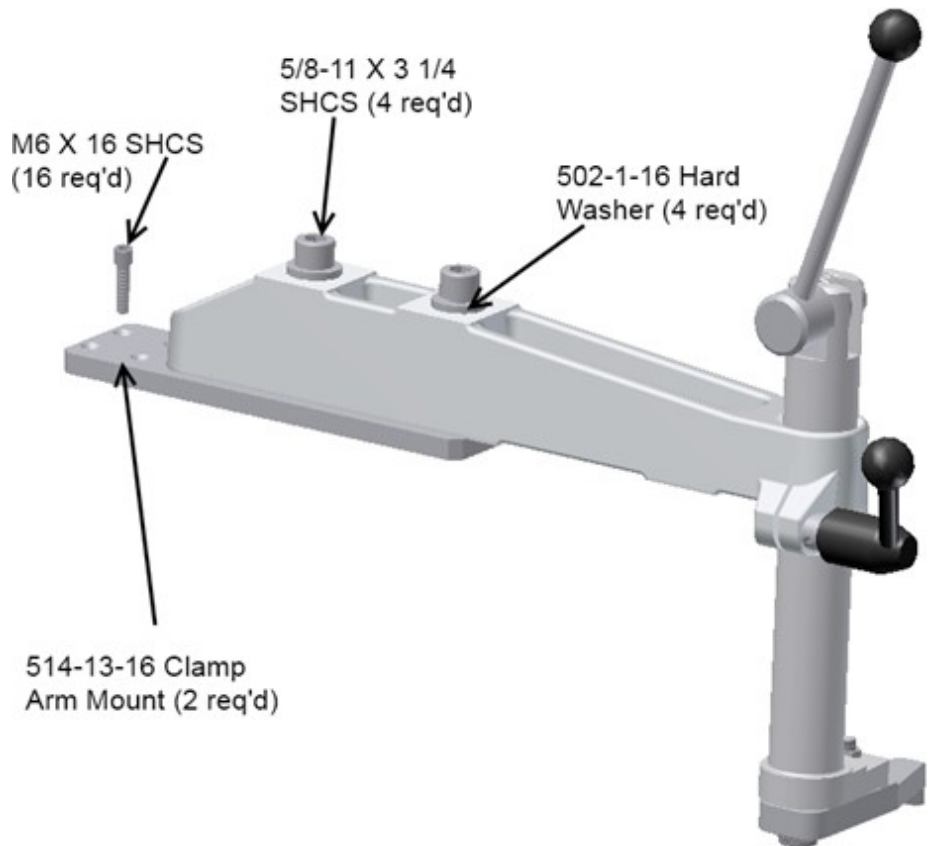

11115 Parallele da 2" (50 mm) X 3" (75 mm)

Venduto solo come assemblaggio completo.



11112C Scanalatura a T universale per carichi pesanti da 8" (203 mm) Parti parallele

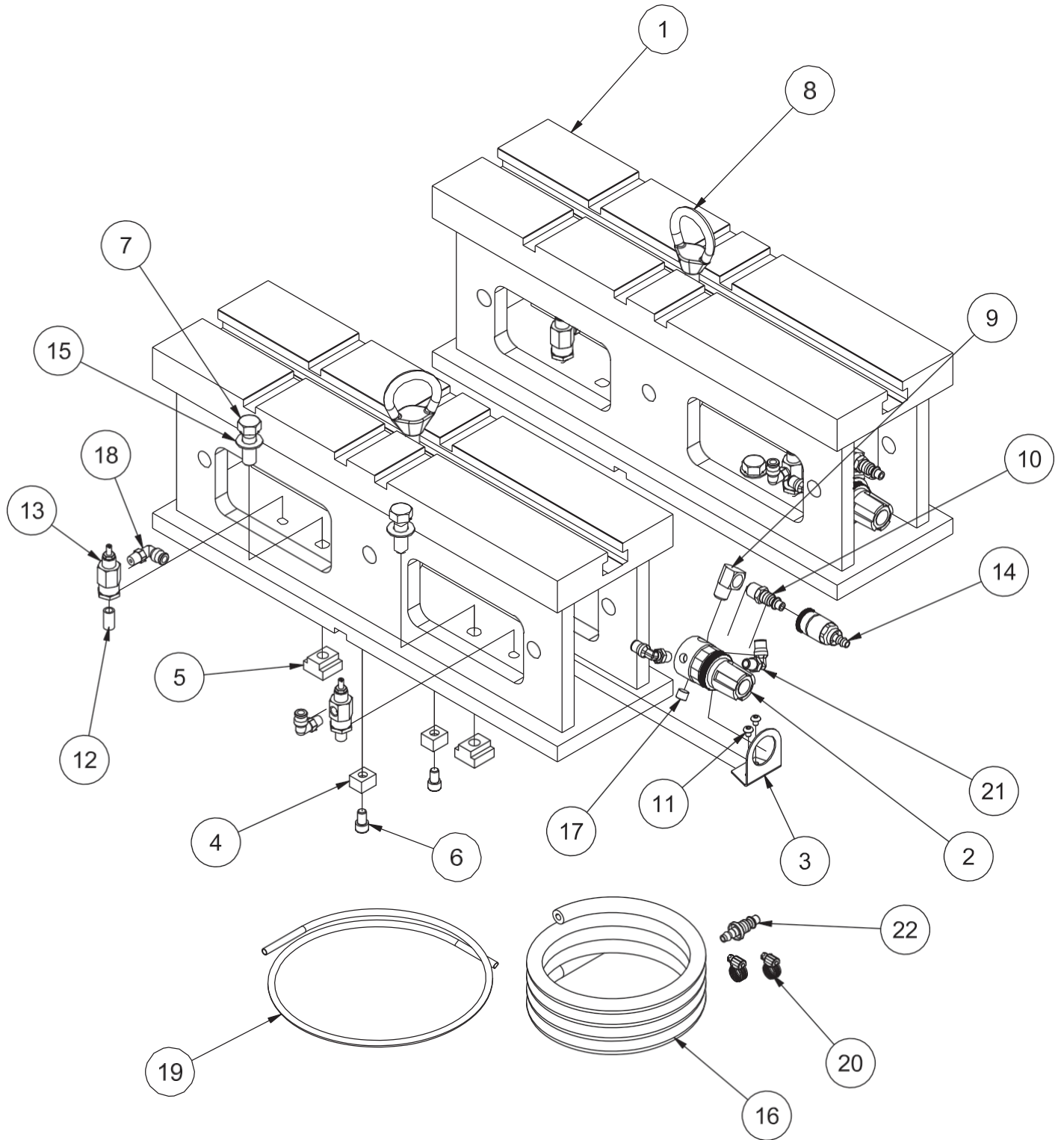

11112
8" SUPPORT PARALLEL ASSEMBLY
F70

11112 SUPPORT PARALLEL ASSEMBLY 8" - F70			
ITEM	QTY	PART NUMBER	DESCRIPTION
1	2	11112A	SUPPORT PARALLEL 8" (MACHINING) - F70
2	2	502-27-17	Regulator 0 - 60 PSI
3	2	502-27-17A	Regulator Bracket
4	4	650-3-9	Key
5	4	650-3-10	TN-5 T-Nut
6	4	MF-21A	5/16-18UNC x 1/2" LG. S.H.C.S.
7	4	MF-137A	1/2-13UNC x 1-1/2" LG. HEX BOLT
8	2	502-3-13	Lift Eye
9	2	502-11-17S	1/4 STREET ELL
10	2	502-11-16X	CONNECTOR, MALE THREAD 1/4 NPTF V6/V8 FIXTURE
11	4	MF-87	10-24UNC x 1/4" LG. SOCKET BUTTONHEAD SCREW
12	4	502-11-17J	Nipple, Close 1/8" NPT
13	4	502-11-35A	Flo Control
14	1	502-11-16W	Quick connect air fitting female
15	4	MF-180	1/2" FLAT WASHER
16	15 FT.	502-1-98	1/4" AIR HOSE
17	2	MF-234	Countersunk Hex-Head Plug 1/8
18	4	514-4-17E	ELBOW, 90 DEGREE MALE - 1/4" POLY X 1/8" NPT
19	4 FT.	502-11-15	TUBING, BLACK POLYFLO 1/4" O.D
20	2	502-1-97	CLAMP, 1/4" I.D. HOSE
21	4	514-4-17V	FITTING 1/8 NPT X 1/4 POLY-90 DEGREE
22	1	502-11-16Y	CONNECTOR, MALE AIR 1/4 NPTF

11114C Scanalatura a T universale per carichi pesanti da 16" (405 mm) Parti parallele

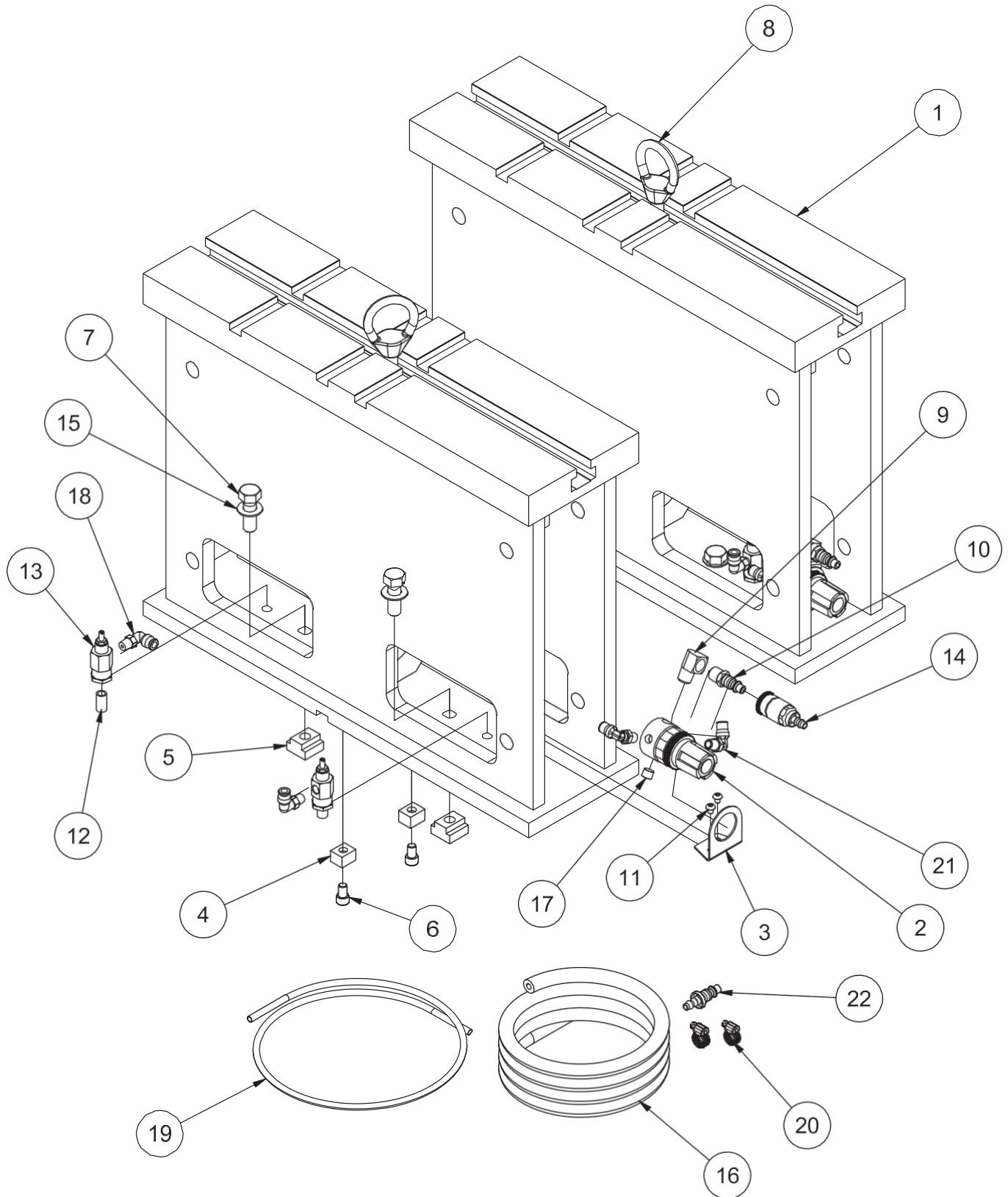

11114
16" SUPPORT PARALLEL ASSEMBLY
F70

11114 SUPPORT PARALLEL ASSEMBLY 16" - F70			
ITEM	QTY	PART NUMBER	DESCRIPTION
1	2	11114A	SUPPORT PARALLEL 16" (MACHINING) - F70
2	2	502-27-17	Regulator 0 - 60 PSI
3	2	502-27-17A	Regulator Bracket
4	4	650-3-9	Key
5	4	650-3-10	TN-5 T-Nut
6	4	MF-21A	5/16-18UNC x 1/2" LG. S.H.C.S.
7	4	MF-137A	1/2-13UNC x 1-1/2" LG. HEX BOLT
8	2	502-3-13	Lift Eye
9	2	502-11-17S	1/4 STREET ELL
10	2	502-11-16X	CONNECTOR, MALE THREAD 1/4 NPTF V6/V8 FIXTURE
11	4	MF-87	10-24UNC x 1/4" LG. SOCKET BUTTONHEAD SCREW
12	4	502-11-17J	Nipple, Close 1/8" NPT
13	4	502-11-35A	Flo Control
14	1	502-11-16W	Quick connect air fitting female
15	4	MF-180	1/2" FLAT WASHER
16	15 FT.	502-1-98	1/4" AIR HOSE
17	2	MF-234	Countersunk Hex-Head Plug 1/8
18	4	514-4-17E	ELBOW, 90 DEGREE MALE - 1/4" POLY X 1/8" NPT
19	4 FT.	502-11-15	TUBING, BLACK POLYFLO 1/4" O.D
20	2	502-1-97	CLAMP, 1/4" I.D. HOSE
21	4	514-4-17V	FITTING 1/8 NPT X 1/4 POLY-90 DEGREE
22	1	502-11-16Y	CONNECTOR, MALE AIR 1/4 NPTF

Dispositivo per la levigatura di più camicie di cilindro (4 camicie)

514-11-5 Parti del dispositivo di levigatura della camicia del cilindro

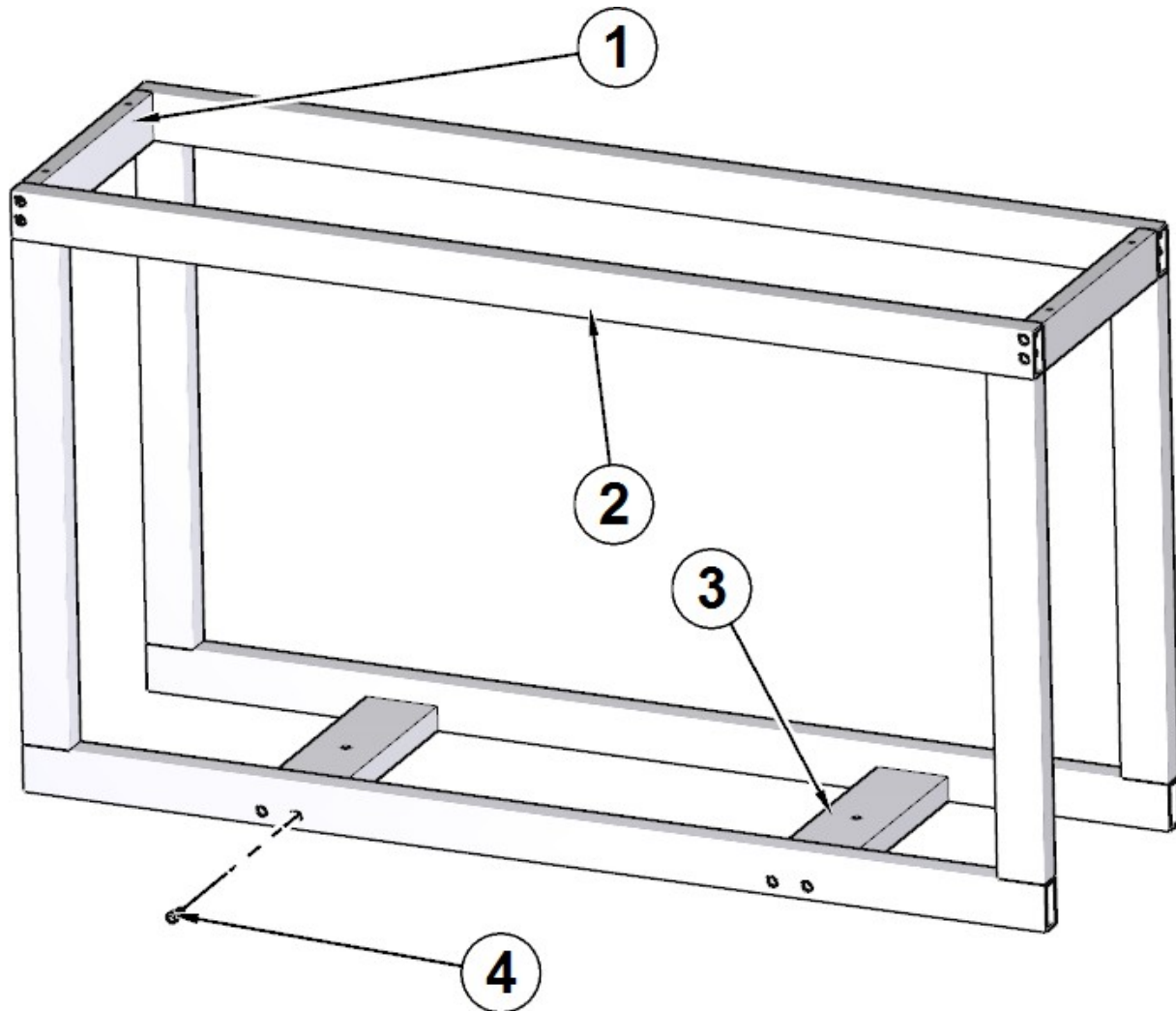

ITEM	PART #	DESCRIPTION
1	514-11-1D	UPPER CROSS BAR
2	514-11-5B	SIDE, SLEEVE FIXTURE
3	514-11-1E	LOWER CROSS BAR
4	MF-21	SOCKET HEAD CAP SCREW 5/16-18 X 5/8"

514-11-6 Parti della piastra di fissaggio

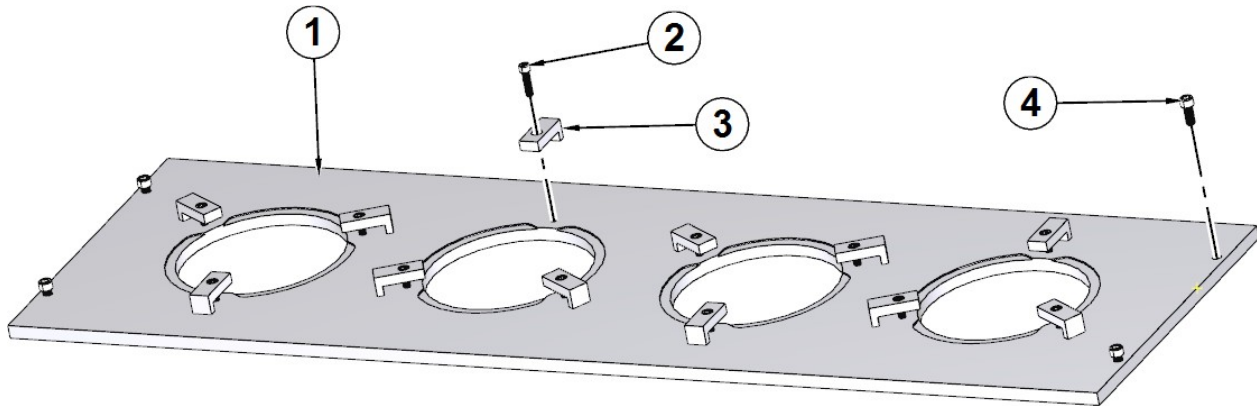

ITEM	PART #	DESCRIPTION
1	514-11-6B	PLATE, CAT 3400 SLEEVE FIXTURE
2	MF-15	SOCKET HEAD CAP SCREW 1/4-20 X 1"
3	514-11-2C	CLAMP, FIXTURE PLATE
4	MF-22	SOCKET HEAD CAP SCREW 5/16-18 X 3/4"

514-11-7 Parti della piastra di fissaggio

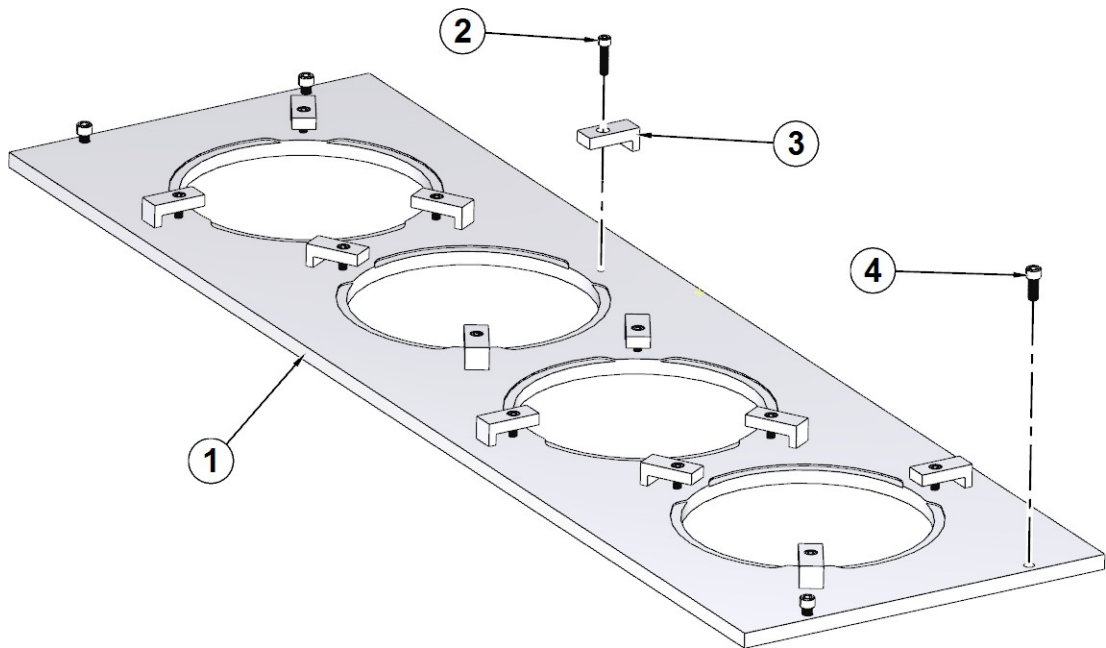

ITEM	PART #	DESCRIPTION
1	514-11-7B	PLATE, CAT 3500 SLEEVE FIXTURE
2	MF-15	SOCKET HEAD CAP SCREW 1/4-20 X 1"
3	514-11-2C	CLAMP, FIXTURE PLATE
4	MF-22	SOCKET HEAD CAP SCREW 5/16-18 X 3/4"

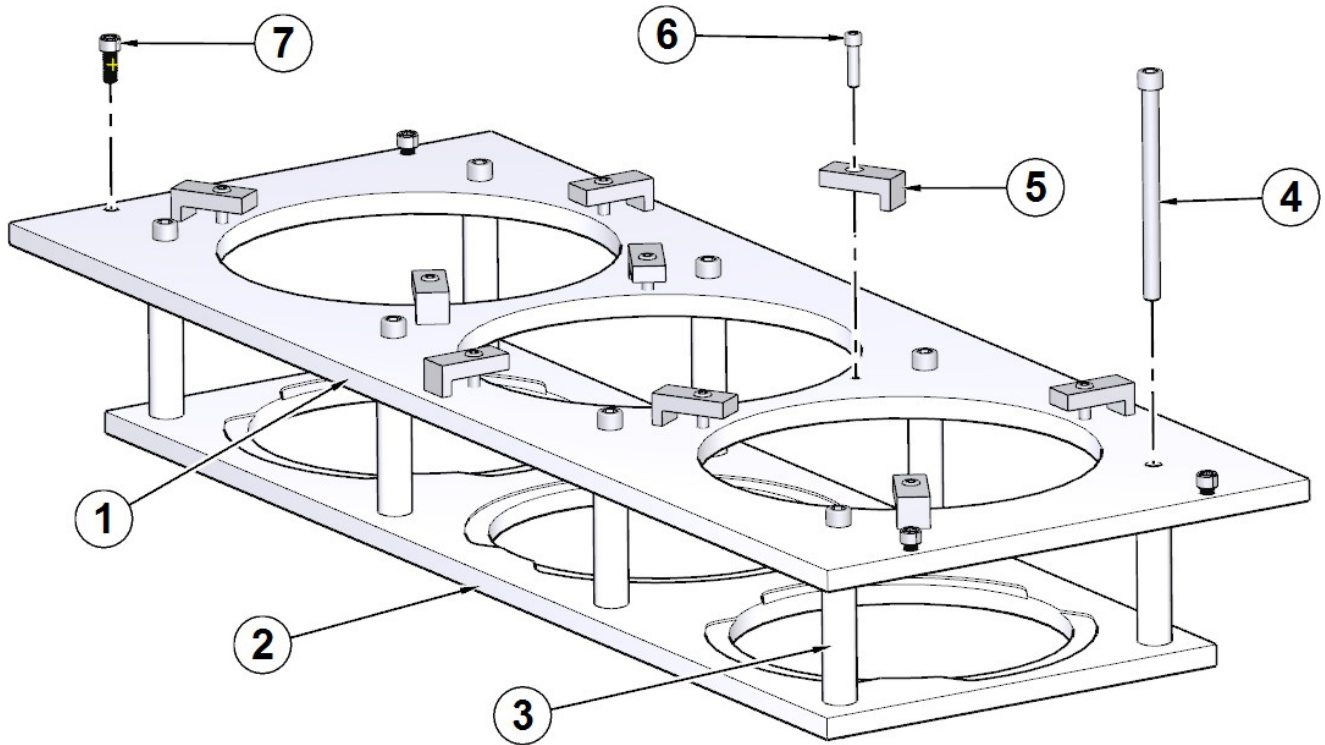
514-11-4 Parti della piastra di fissaggio

ITEM	PART #	DESCRIPTION
1	514-11-4A	UPPER FIXTURE PLATE
2	514-11-4C	LOWER FIXTURE PLATE
3	514-11-4E	SPACER,CAT C175 FIXTURE PLATE ASSEMBLY
4	MF-38	SOCKET HEAD CAP SCREW 3/8-16 X 5"
5	514-11-2C	CLAMP, FIXTURE PLATE
6	MF-15	SOCKET HEAD CAP SCREW 1/4-20 X 1"
7	MF-22	SOCKET HEAD CAP SCREW 5/16-18 X 3/4"

Attrezzatura opzionale per refrigerante e filtri

514-4-71C Refrigerante sintetico

(per l'uso con pietre diamantate) 5 gal (20 litri) (miscelare con acqua 20:



514-4-71D Rifrattore di liquido di raffreddamento

Venduto solo come kit di gara.



514-2-42C Cartuccia filtrante di ricambio a doppia gradazione 50-5 Micron

Per il sistema di filtraggio standard

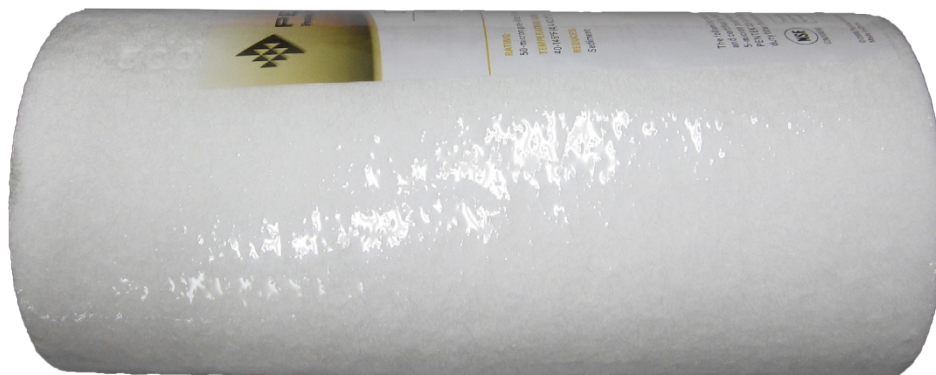

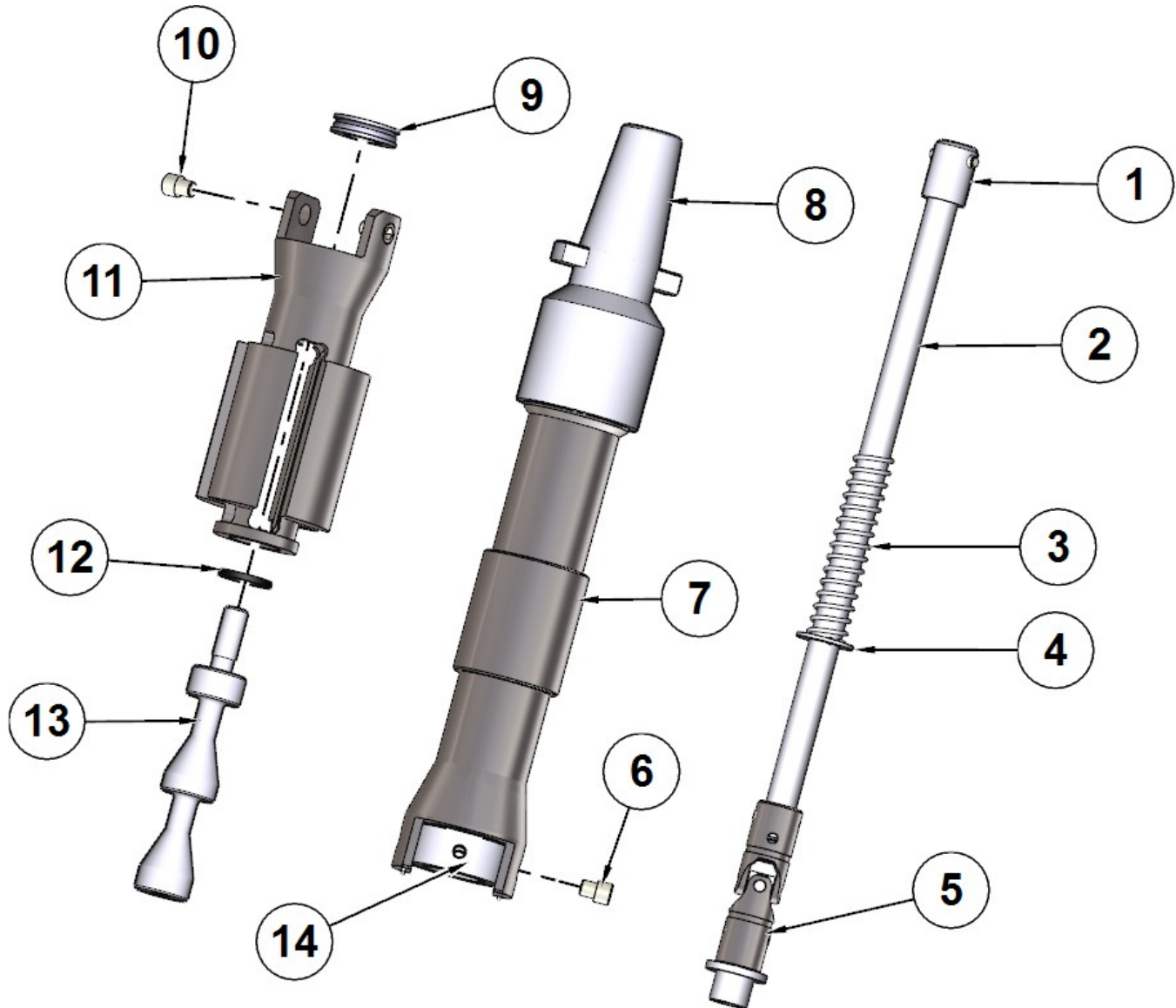
Teste di affilatura di precisione Rottler, manicotti e portapietre opzionali**514-9 J Medium Rottler Precision 4 Stone Holder Hone Head Assembly Parts**

ITEM	PART #	DESCRIPTION
1	514-6-44	COUPLING, DRIVEN
2	514-10-20B	SHAFT, ADJUSTING
3	514-5-72A	SPRING, COMPRESSION
4	100-19	WASHER, THRUST
5	514-10-5A	JOINT, UNIVERSAL ASSY
6	514-10-10	SCREW, PIVOT
7	514-10-20A	YOKE
8	514-13-49	ADAPTER, KWIK SWITCH
9	514-7-82F	BEARING, THRUST
10	514-10-10	SCREW, PIVOT
11	514-10-1A	BODY
12	7209H	BUMPER
13	514-10-2A	CONE ROD
14	514-10-6	BLOCK, PIVOT

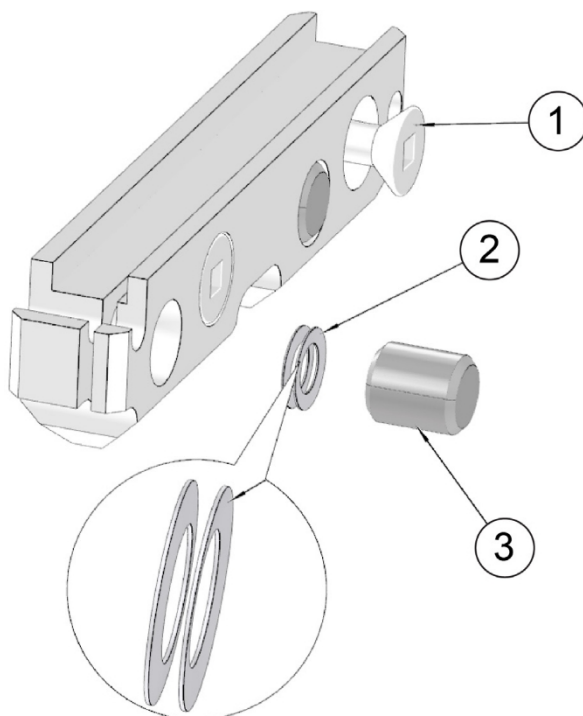
514-10 -Parti del portasassi serie 13

ITEM	PART #	DESCRIPTION
1	514-7-81J	SCREW, FLAT HEAD SQUARE DRIVE
2	514-10-11D	SPRING, BELLEVILLE
3	514-10-11C	PIN, DAMPENING

Tabella delle dimensioni delle pietre per affilatura media

Diametro (Nuove pietre)

	0,312 Pietre		0,200 Pietre	
	Min	Massimo	Min	Massimo
514-10-13A	2.34	2.45	2.20	2.23
514-10-13F	2.44	2.55	2.22	2.33
514-10-13B	2.54	2.65	2.32	2.43
514-10-13G	2.64	2.75	2.42	2.53
514-10-13C	2.74	2.85	2.52	2.63
514-10-13H	2.84	2.95	2.62	2.73
514-10-13D	2.94	3.05	2.72	2.83

Diametro (pietre nuove) (metrico)

	7,925 Pietre		5.08 Pietre	
	Min	Massimo	Min	Massimo
514-10-13A	59.44	62.23	53.75	56.54
514-10-13F	61.98	64.77	56.29	59.08
514-10-13B	64.52	67.31	58.83	61.62
514-10-13G	67.06	69.85	61.37	64.16
514-10-13C	69.60	72.39	63.91	66.70
514-10-13H	72.14	74.93	66.45	69.24
514-10-13D	74.68	77.47	68.99	71.78

Diametro (nuove spazzole)

	0,550 Spazzole		0,395 Spazzole	
	Min	Massimo	Min	Massimo
514-10-13A	2.82	2.93	2.51	2.62
514-10-13F	2.92	3.03	2.61	2.72
514-10-13B	3.02	3.13	2.71	2.82
514-10-13G	3.12	3.23	2.81	2.92
514-10-13C	3.22	3.33	2.91	3.02
514-10-13H	3.32	3.43	3.01	3.12
514-10-13D	3.42	3.53	3.11	3.22

Diametro (spazzole nuove) (metrico)

	13.970 Spazzole		10.033 Spazzole	
	Min	Massimo	Min	Massimo
514-10-13A	71.53	74.32	63.65	66.45
514-10-13F	74.07	76.86	66.19	68.99
514-10-13B	76.61	79.40	68.73	71.53
514-10-13G	79.15	81.94	71.27	74.07
514-10-13C	81.69	84.48	73.81	76.61
514-10-13H	84.23	87.02	76.35	79.15
514-10-13D	86.77	89.56	78.89	81.69

514-9Q Grande Rottler Precision Heavy Duty 6 Stone Holder Hone Head Assembly Parts

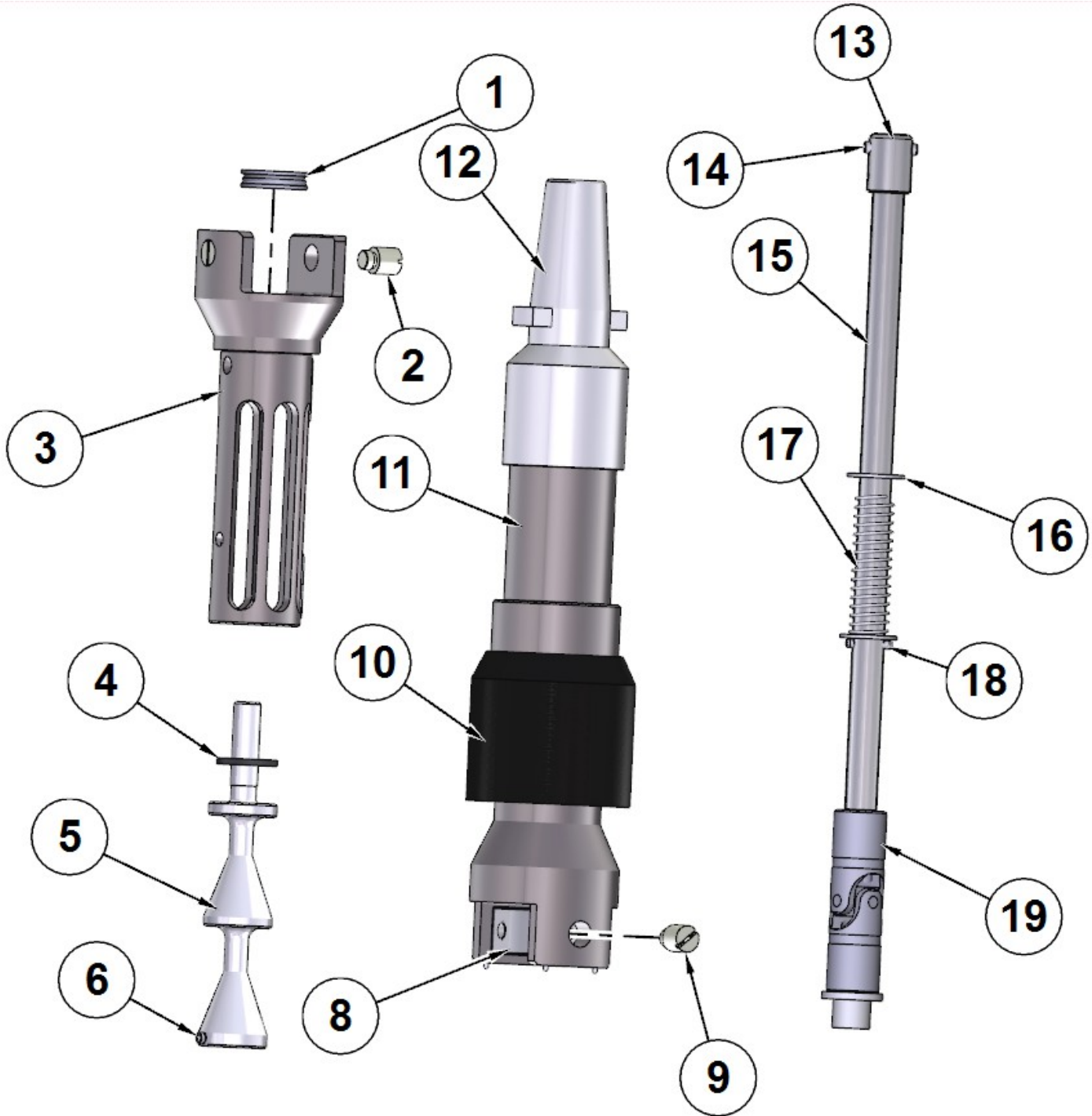

ITEM	PART #	DESCRIPTION
1	514-7-82F	BEARING, THRUST
2	514-5-66G	PIN, THREADED
3	514-9-10D	BODY, LARGE HEAVY DUTY HONE HEAD
4	514-7-82G	RING, SQUARE CROSS SECTION
5	514-9-7A	CONE ROD
6	MF-223C	ROLL PIN 3/16 X 5/8"
8	514-7-81S	PIVOT BLOCK
9	514-5-66G	PIN, THREADED
10	514-9-10G	COVER, HONE HEAD U-JOINT
11	514-7-81T	YOKE, DRIVE SHAFT
12	514-13-49	ADAPTER, KWIK SWITCH
13	514-6-44	COUPLING, DRIVEN
14	MF-198A	DOWEL PINS 3/16 X 7/8"
15	514-7-81U	SHAFT, ADJUSTING HONE HEAD
16	100-19	WASHER, THRUST
17	514-5-72A	SPRING, COMPRESSION
18	MF-219	ROLL PIN 1/8 X 3/4"
19	514-9-8A	JOINT, UNIVERSAL ASSY

514-9S Grande Rottler Precision Heavy Duty 6 Stone Holder Hone Head Assembly Parts

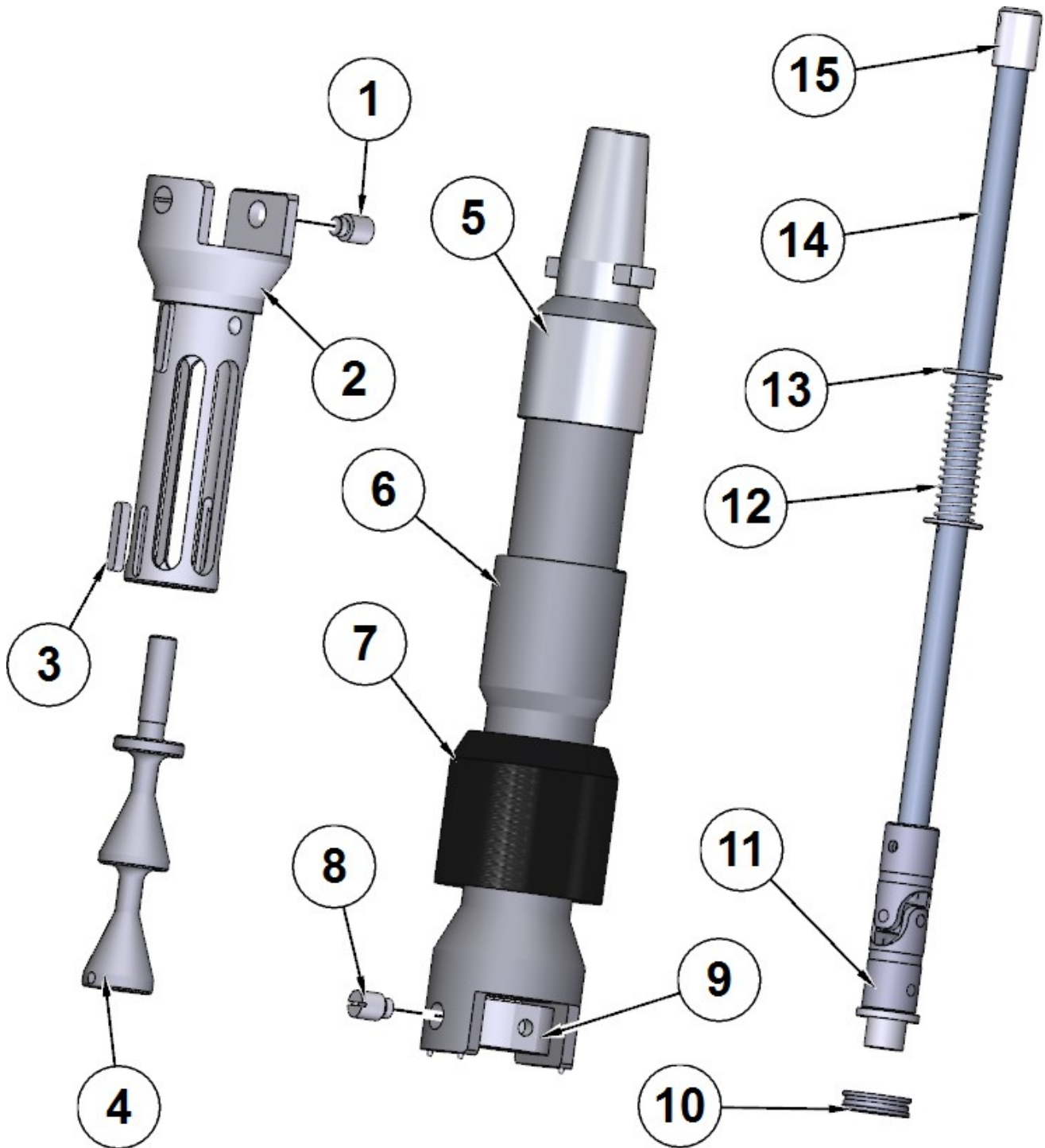

ITEM	PART #	DESCRIPTION
1	514-5-66G	PIN, THREADED
2	514-9-10D	BODY, LARGE HEAVY DUTY HONE HEAD
3	514-7-83C	KEY,SLEEVE
4	514-9-7A	CONE ROD
5	514-13-49	ADAPTER, KWIK SWITCH
6	514-7-81R	YOKE, DRIVE SHAFT
7	514-9-10G	COVER, HONE HEAD U-JOINT
8	514-5-66G	PIN, THREADED
9	514-7-81S	PIVOT BLOCK
10	514-7-82F	BEARING, THRUST
11	514-9-8A	JOINT, UNIVERSAL ASSY
12	514-5-72A	SPRING, COMPRESSION
13	100-19	WASHER, THRUST
14	514-7-81B	SHAFT, ADJUSTING HONE HEAD
15	514-6-44	COUPLING, DRIVEN



514-9-4 E Parti del gruppo manicotto

ITEM	PART #	DESCRIPTION
1	514-9-3E	SLEEVE ONLY (6 STONE) 2.77 TO 3.88" DIAMETER
2	MF-217	ROLL PIN 1/8 X 1/2"
3	514-7-83D	SCREW, SOCKET SET CONE POINT
4	514-7-83K	SPRING,GARTER
5	6147D	TYRAP

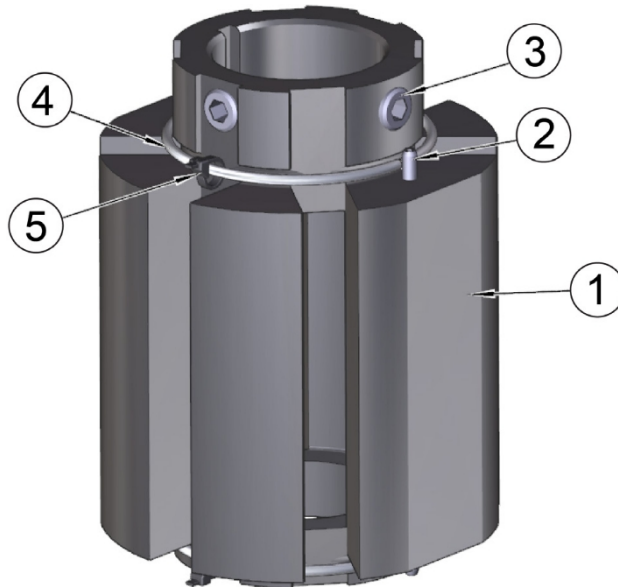

514-9-4 F Parti del gruppo manicotto

ITEM	PART #	DESCRIPTION
1	514-9-3F	SLEEVE ONLY (6 STONE) 3.67 TO 4.63" DIAMETER
2	MF-217	ROLL PIN 1/8 X 1/2"
3	514-7-83D	SCREW, SOCKET SET CONE POINT
4	514-7-83K	SPRING,GARTER
5	6147D	TYRAP

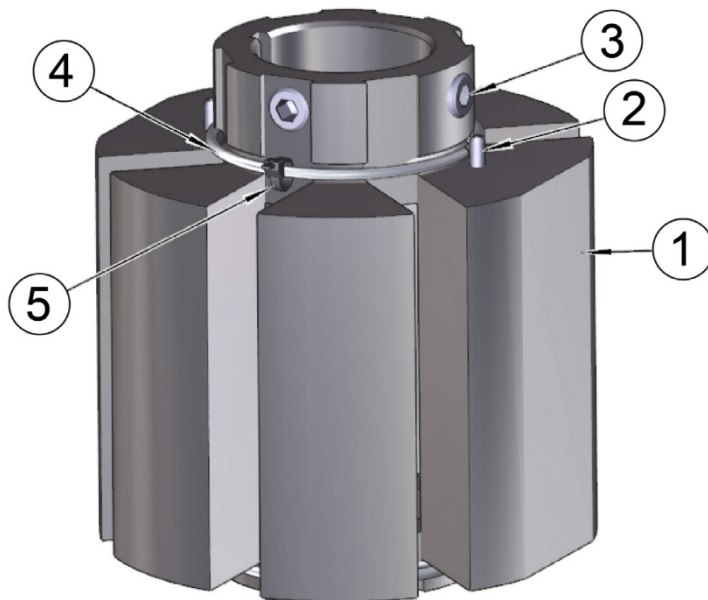
514-9-4 G Parti del gruppo manicotto

ITEM	PART #	DESCRIPTION
1	514-9-3G	SLEEVE ONLY (6 STONE) 4.42 TO 7.38" DIAMETER
2	MF-217	ROLL PIN 1/8 X 1/2"
3	514-7-83D	SCREW, SOCKET SET CONE POINT
4	514-7-83K	SPRING, GARTER
5	6147D	TYRAP

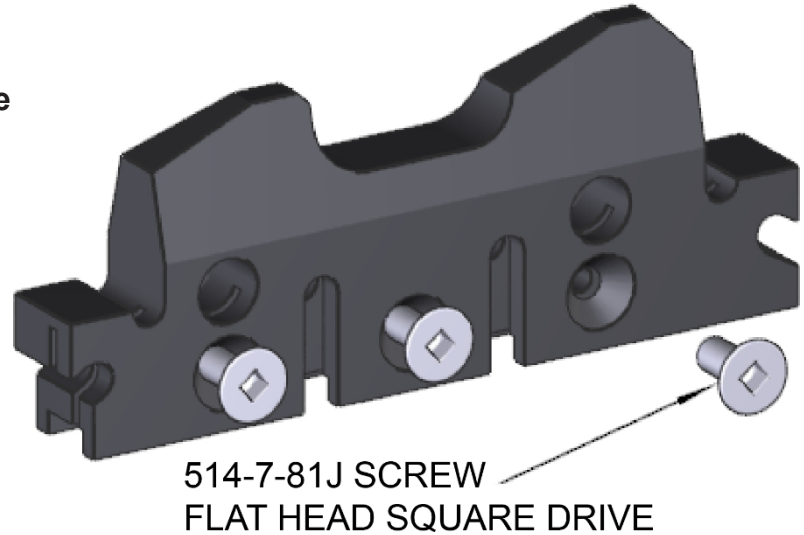
514-9-31 Parti dei portapietre della serie

Tabella delle dimensioni della pietra della testa di Six Stone Hone

	Diametro (Nuove pietre)			
	0,312 Pietre		0,200 Pietre	
	Min	Massimo	Min	Massimo
514-9-31J	2.99	3.45	2.77	3.23
514-9-31A	3.17	3.63	2.94	3.41
514-9-31B	3.42	3.88	3.19	3.66
514-9-31C	3.67	4.13	3.44	3.91
514-9-31D	3.92	4.38	3.69	4.16
514-9-31E	4.17	4.63	3.94	4.41
514-9-31F	4.42	4.88	4.19	4.66
514-9-31G	4.67	5.13	4.44	4.91
514-9-31H	4.92	5.38	4.69	5.16
514-9-31K	5.17	5.63	4.94	5.41
514-9-31L	5.42	5.88	5.19	5.66
514-9-31M	5.67	6.13	5.44	5.91
514-9-31N	5.92	6.38	5.69	6.16
514-9-31P	6.17	6.63	5.94	6.41
514-9-31Q	6.42	6.88	6.19	6.66
514-9-31R	6.67	7.13	6.44	6.91
514-9-31S	6.92	7.38	6.69	7.16

Diametro (pietre nuove) (metrico)				
	7,9248 Pietre		5.08 Pietre	
	Min	Massimo	Min	Massimo
514-9-31J	75.92	87.73	70.23	82.04
514-9-31A	80.39	92.20	74.70	86.51
514-9-31B	86.74	98.55	81.05	92.86
514-9-31C	93.09	104.90	87.40	99.21
514-9-31D	99.44	111.25	93.75	105.56
514-9-31E	105.79	117.60	100.10	111.91
514-9-31F	112.14	123.95	106.45	118.26
514-9-31G	118.49	130.30	112.80	124.61
514-9-31H	124.84	136.65	119.15	130.96
514-9-31K	131.19	143.00	125.50	137.31
514-9-31L	137.54	149.35	131.85	143.66
514-9-31M	143.89	155.70	138.20	150.01
514-9-31N	150.24	162.05	144.55	156.36
514-9-31P	156.59	168.40	150.90	162.71
514-9-31Q	162.94	174.75	157.25	169.06
514-9-31R	169.29	181.10	163.60	175.41
514-9-31S	175.64	187.45	169.95	181.76

Diametro (nuove spazzole)				
	0,550 Spazzole		0,395 Spazzole	
	Min	Massimo	Min	Massimo
514-9-31J	3.47	3.93	3.16	3.62
514-9-31A	3.64	4.11	3.33	3.80
514-9-31B	3.89	4.36	3.58	4.05
514-9-31C	4.14	4.61	3.83	4.30
514-9-31D	4.39	4.86	4.08	4.55
514-9-31E	4.64	5.11	4.33	4.80
514-9-31F	4.89	5.36	4.58	5.05
514-9-31G	5.14	5.61	4.83	5.30
514-9-31H	5.39	5.86	5.08	5.55
514-9-31K	5.64	6.11	5.33	5.80
514-9-31L	5.89	6.36	5.58	6.05
514-9-31M	6.14	6.61	5.83	6.30
514-9-31N	6.39	6.86	6.08	6.55
514-9-31P	6.64	7.11	6.33	6.80
514-9-31Q	6.89	7.36	6.58	7.05
514-9-31R	7.14	7.61	6.83	7.30
514-9-31S	7.39	7.86	7.08	7.55

Diametro (spazzole nuove) (metrico)				
	13,97 Spazzole		10.033 Spazzole	
	Min	Massimo	Min	Massimo
514-9-31J	88.01	99.82	80.14	91.95
514-9-31A	92.48	104.29	84.61	96.42
514-9-31B	98.83	110.64	90.96	102.77
514-9-31C	105.18	116.99	97.31	109.12
514-9-31D	111.53	123.34	103.66	115.47
514-9-31E	117.88	129.69	110.01	121.82
514-9-31F	124.23	136.04	116.36	128.17
514-9-31G	130.58	142.39	122.71	134.52
514-9-31H	136.93	148.74	129.06	140.87
514-9-31K	143.28	155.09	135.41	147.22
514-9-31L	149.63	161.44	141.76	153.57
514-9-31M	155.98	167.79	148.11	159.92
514-9-31N	162.33	174.14	154.46	166.27
514-9-31P	168.68	180.49	160.81	172.62
514-9-31Q	175.03	186.84	167.16	178.97
514-9-31R	181.38	193.19	173.51	185.32
514-9-31S	187.73	199.54	179.86	191.67

Abrasivi diamantati per teste di levigatura Rottler Precision 6 Stone Holder

NOTA: Ra - Ruvidità media. Il valore prima di Ra è in micropollici. Il valore tra parentesi um è in micro metri.
 Lunghezza indica la lunghezza della pietra. Altezza indica lo spessore della pietra.

Pietre diamantate, .312 (7,90MM), set di 6 pietre

514-9-32F Pietre diamantate, grana 80

Set di 6 pezzi lunghi 3" (76 mm), 90 Ra, (2,25um)

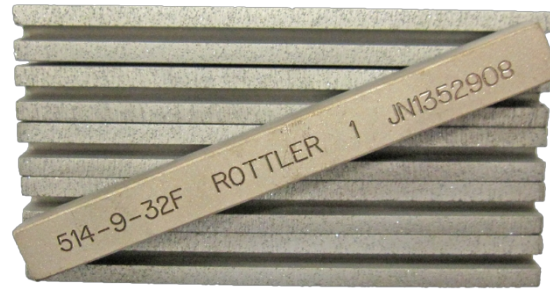

514-9-32R Pietre diamantate grana 80

Set di 6 pezzi lunghi 3,5" (89 mm), 90 Ra, (2,25um)



514-9-32W Pietre diamantate, grana 140/170

Set di 6 da 3" (76 mm), 50-75 Ra, (1,25 - 1,875um)

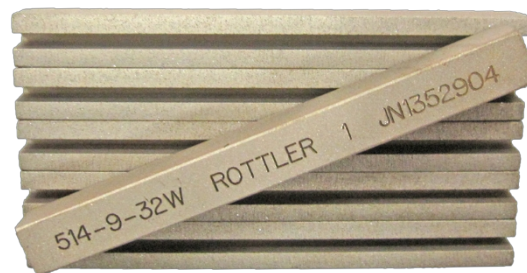

514-9-32K Pietre diamantate, grana 170/200

Set di 6 pezzi lunghi 3" (76 mm), 45-60 Ra, (1,125 - 1,5um)



514-9-32J Pietre diamantate, grana 270/325

Set di 6 pezzi lunghi 3" (76 mm), 35-45 Ra, (.875 - 1.125um)

514-9-32 E Pietre diamantate, grana 325/400

Set di 6 da 3" (76 mm), 24-30 Ra, (.6 - .75um)

514-9-32 C Pietre diamantate, grana 500

Set di 6 da 3" (76 mm), 18-22 Ra, (.45 - .55um)

514-9-32 L Pietre diamantate, grana 550

Set di 6 da 3" (76 mm), 15-19 Ra, (.375 - .475)



514-9-32 G Pietre diamantate, grana 600

Set di 6 da 3" (76 mm), 8-12 Ra, (.2 - .3um)

514-9-33 Pietre diamantate, grana 800

Set di 6 pezzi lunghi 3" (76 mm)

514-9-33 C Pietre diamantate, grana 800

Set di 6 pezzi lunghi 4" (102 mm)

514-9-33 J Pietre diamantate, grana 1200

Set di 6 pezzi lunghi 3" (76 mm)



Pietre diamantate, .200 (5,08MM), set di 6 pietre
514-9-33 B Pietre diamantate, grana 270/325

Set di 6 pezzi lunghi 3,5" (89 mm), 35-45 Ra,

514-9-32 D Pietre diamantate, grana 325/400

Set di 6 pezzi lunghi 3" (76 mm), 18-22 Ra, alesaggio 2,795

514-9-33 A Pietre diamantate, grana 800

Set di 6 pezzi lunghi 3,5" (89 mm)

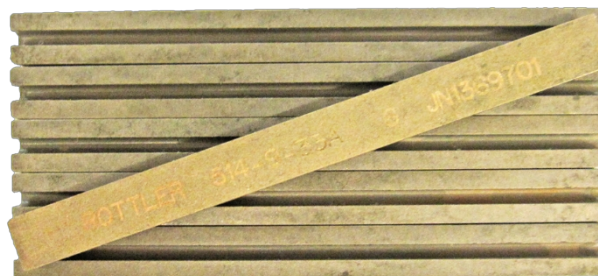

Pietre in CBN per la superfinitura con le teste di affilatura Rottler Precision a 4 e 6 pietre

514-9-35C Pietre CBN, grana 320

Set di 4 pezzi lunghi 3" (76 mm), per una super finitura



514-9-35D Pietre CBN, grana 400

Set di 4 pezzi lunghi 3" (76 mm), per una super finitura



514-9-35B Pietre CBN, grana 600

Set di 4 pezzi lunghi 3" (76 mm), per una super finitura



Spazzole per la finitura del piano con le teste di levigatura Rottler Precision 4 e 6 Stone Holder

514-9-14H Spazzole, per finitura a platea

Altezza di .550" (14 mm), lunghezza di 3 1/2" (89 mm), richiede un portapietra di una o due misure più piccolo rispetto alla pietra diamantata di altezza .312" (7,90 mm). Set di 4



514-9-14Y Spazzole, per finitura a platea

Altezza di .395" (10 mm), lunghezza di 3 1/2" (89 mm), richiede un portapietra della stessa misura o di una misura inferiore rispetto alla pietra diamantata di altezza .312" (7,90 mm). Set di 4



514-9P Grande Rottler Precision Heavy Duty 4 Stone Holder Hone Head Assembly Parts

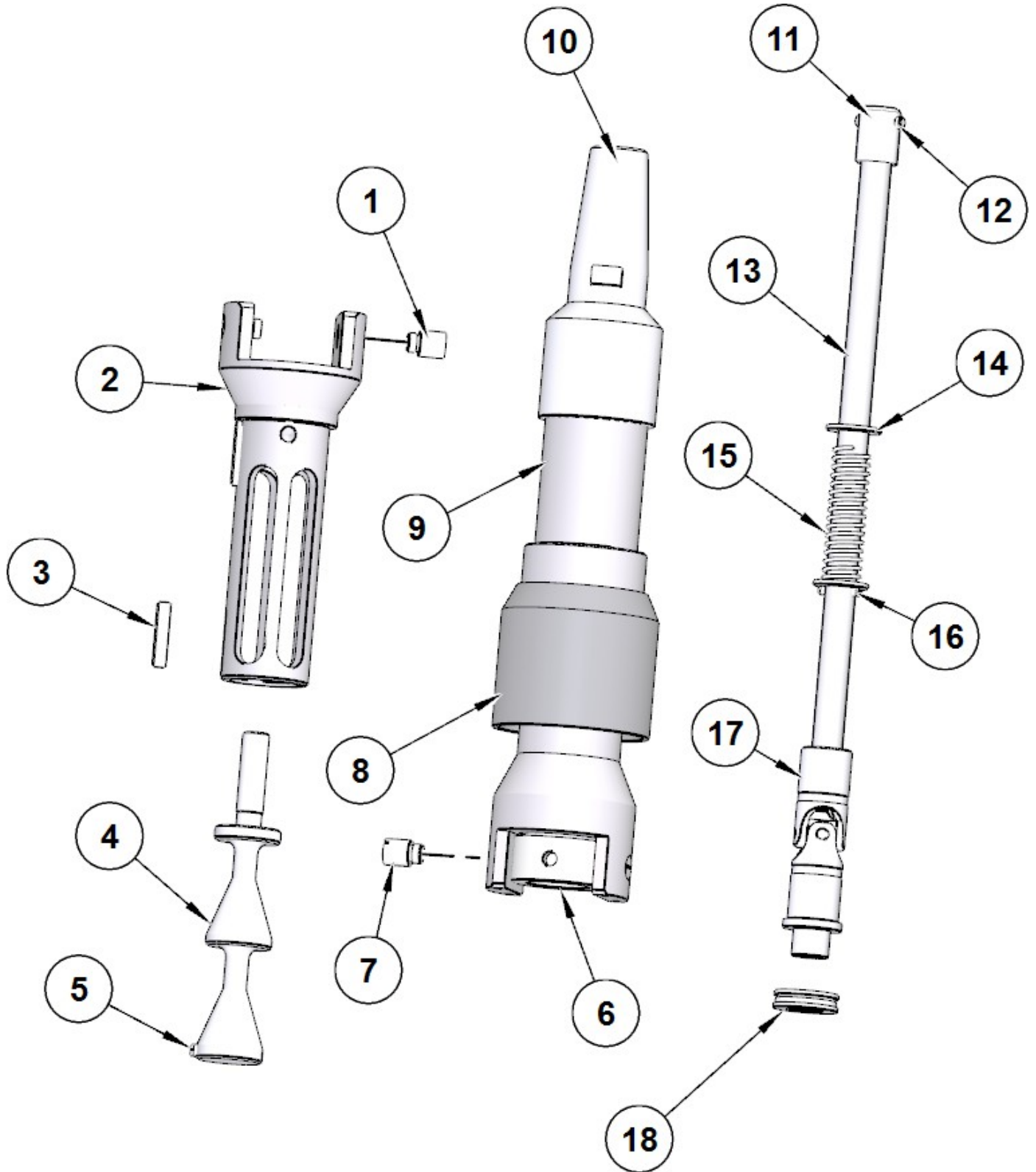

ITEM	PART #	DESCRIPTION
1	514-5-66G	PIN, THREADED
2	514-9-10E	BODY, LARGE HEAVY DUTY HONE HEAD
3	514-7-83C	KEY,SLEEVE
4	514-9-7A	CONE ROD
5	MF-223C	ROLL PIN 3/16 X 5/8"
6	514-7-81S	PIVOT BLOCK
7	514-5-66G	PIN, THREADED
8	514-9-10G	COVER, HONE HEAD U-JOINT
9	514-7-81T	YOKE, DRIVE SHAFT
10	514-13-49	ADAPTER, KWIK SWITCH
11	514-6-44	COUPLING, DRIVEN
12	MF-198A	DOWEL PIN 3/16 X 7/8"
13	514-7-81U	SHAFT, ADJUSTING HONE HEAD
14	100-19	WASHER, THRUST
15	514-5-72A	SPRING, COMPRESSION
16	MF-219	ROLL PIN 1/8 X 3/4"
17	514-9-8A	JOINT, UNIVERSAL ASSY
18	514-7-82F	BEARING, THRUST

514-9R Grande Rottler Precision Heavy Duty 4 Stone Holder Hone Head Assembly Parts

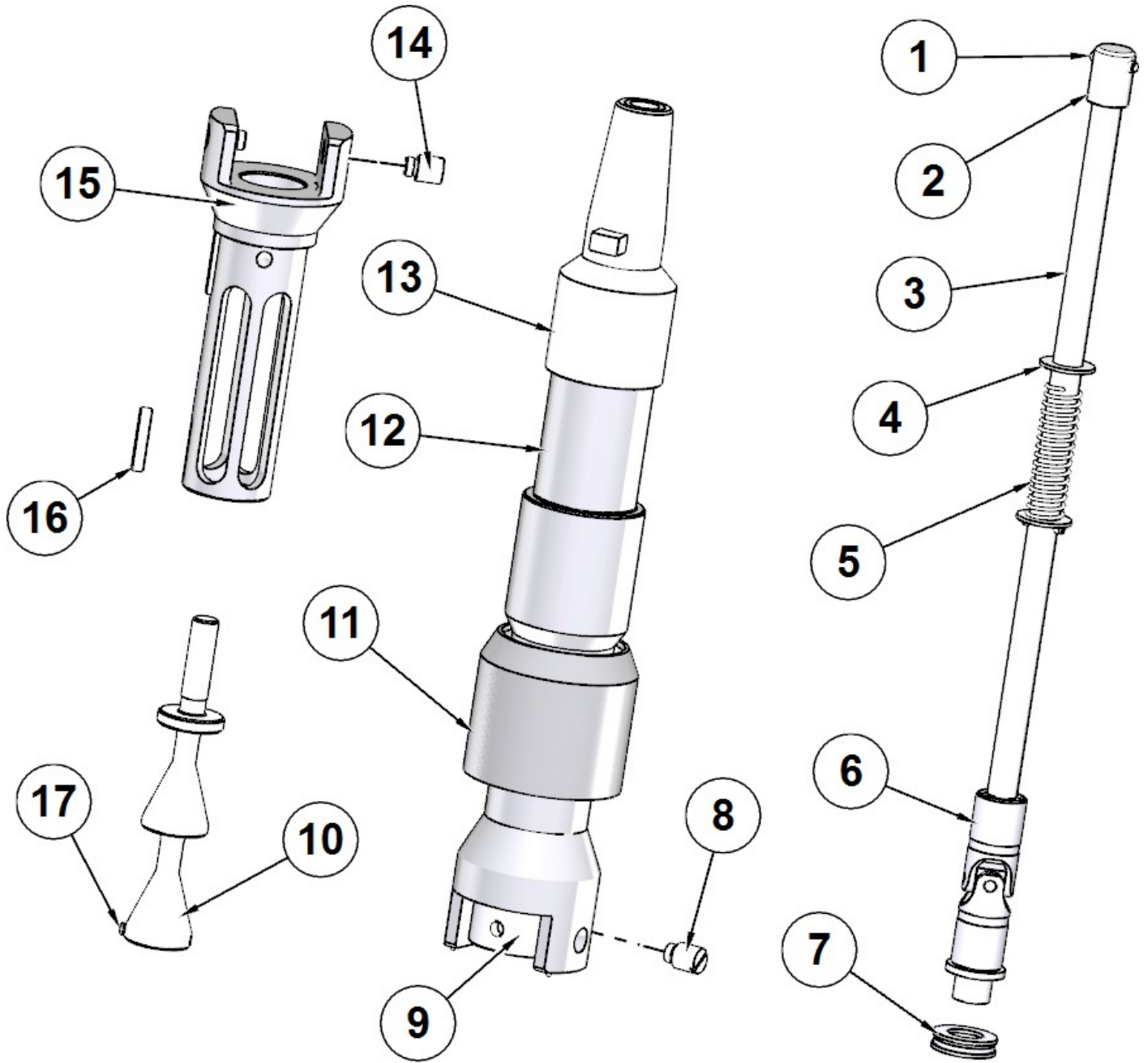

ITEM	PART #	DESCRIPTION
1	MF-198A	DOWEL PIN 3/16 X 7/8"
2	514-6-44	COUPLING, DRIVEN
3	514-7-81B	SHAFT, ADJUSTING HONE HEAD
4	100-19	WASHER, THRUST
5	514-5-72A	SPRING, COMPRESSION
6	514-9-8A	JOINT, UNIVERSAL ASSY
7	514-7-82F	BEARING, THRUST
8	514-5-66G	PIN, THREADED
9	514-7-81S	PIVOT BLOCK
10	514-9-7A	CONE ROD
11	514-9-10G	COVER, HONE HEAD U-JOINT
12	514-7-81R	YOKE, DRIVE SHAFT
13	514-13-49	ADAPTER, KWIK SWITCH
14	514-5-66G	PIN, THREADED
15	514-9-10E	BODY, LARGE HEAVY DUTY HONE HEAD
16	514-7-83C	KEY, SLEEVE
17	MF-223C	ROLL PIN 3/16 X 5/8"

514-9-4 A Parti di montaggio del manicotto

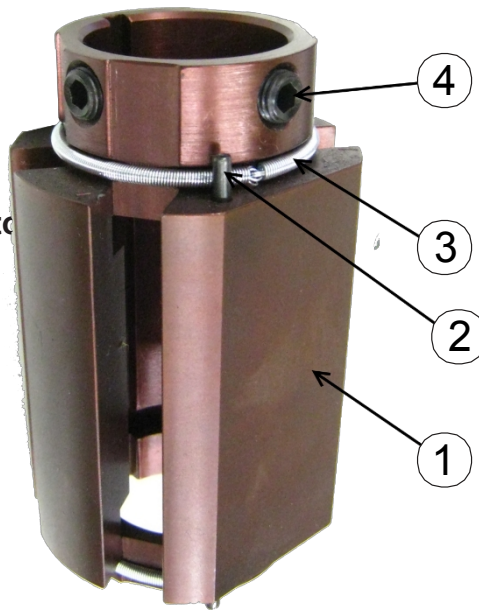

ITEM	PART #	DESCRIPTION
1	514-9-3A	SLEEVE 2.75 TO 3.56" DIA.
2	MF-217	ROLL PIN 1/8 X 1/2"
3	514-7-83K	SPRING,GARTER
4	514-7-83D	SCREW, SOCKET SET CONE POINT

Parti del gruppo manicotto 514-9B

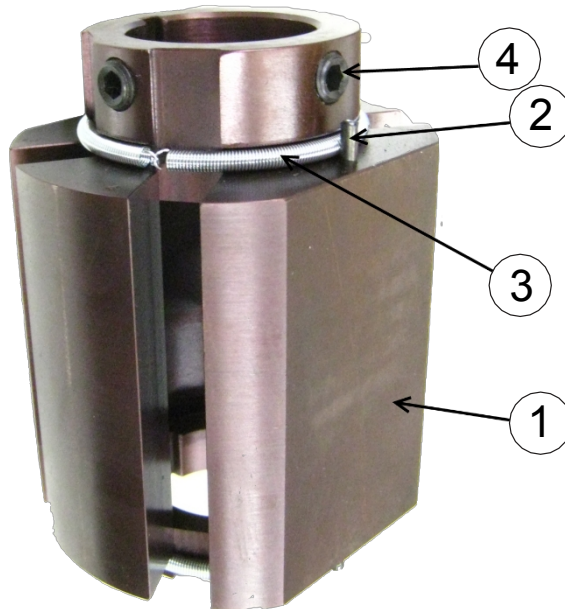

ITEM	PART #	DESCRIPTION
1	514-9-3B	SLEEVE ONLY 3.50-4.32" DIAMETER
2	MF-217	ROLL PIN 1/8 X 1/2"
3	514-7-83K	SPRING,GARTER
4	514-7-83D	SCREW, SOCKET SET CONE POINT

514-9-4 C Parti del gruppo manicotto

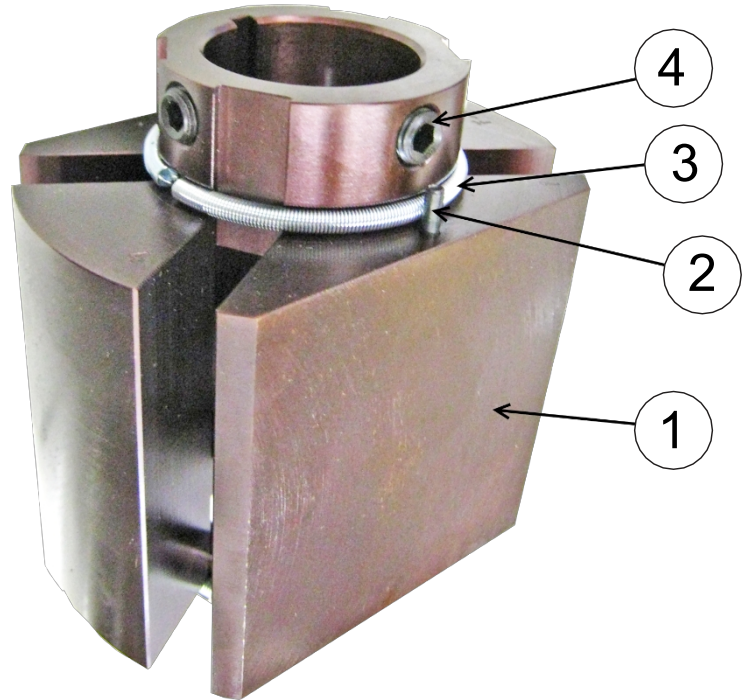

ITEM	PART #	DESCRIPTION
1	514-9-3C	SLEEVE 4.25 TO 5.06" DIAMETER
2	MF-217	ROLL PIN 1/8 X 1/2"
3	514-7-83K	SPRING, GARTER
4	514-7-83D	SCREW, SOCKET SET CONE POINT

Parti del portasassi serie 514-9-6



Tabella delle dimensioni della pietra per affilatura grande

Diametro (Nuove pietre)

	0,312 Pietre		0,200 Pietre	
	Min	Massimo	Min	Massimo
514-9-6J	2.99	3.45	2.77	3.23
514-9-6A	3.17	3.63	2.94	3.41
514-9-6B	3.42	3.88	3.19	3.66
514-9-6C	3.67	4.13	3.44	3.91
514-9-6D	3.92	4.38	3.69	4.16
514-9-6E	4.17	4.63	3.94	4.41
514-9-6F	4.42	4.88	4.19	4.66
514-9-6G	4.67	5.13	4.44	4.91
514-9-6H	4.92	5.38	4.69	5.16
514-9-6K	5.17	5.63	4.94	5.41
514-9-6L	5.42	5.88	5.19	5.66
514-9-6M	5.67	6.13	5.44	5.91
514-9-6N	5.92	6.38	5.69	6.16
514-9-6P	6.17	6.63	5.94	6.41
514-9-6Q	6.42	6.88	6.19	6.66
514-9-6R	6.67	7.13	6.44	6.91
514-9-6S	6.92	7.38	6.69	7.16

Diametro (pietre nuove) (metrico)

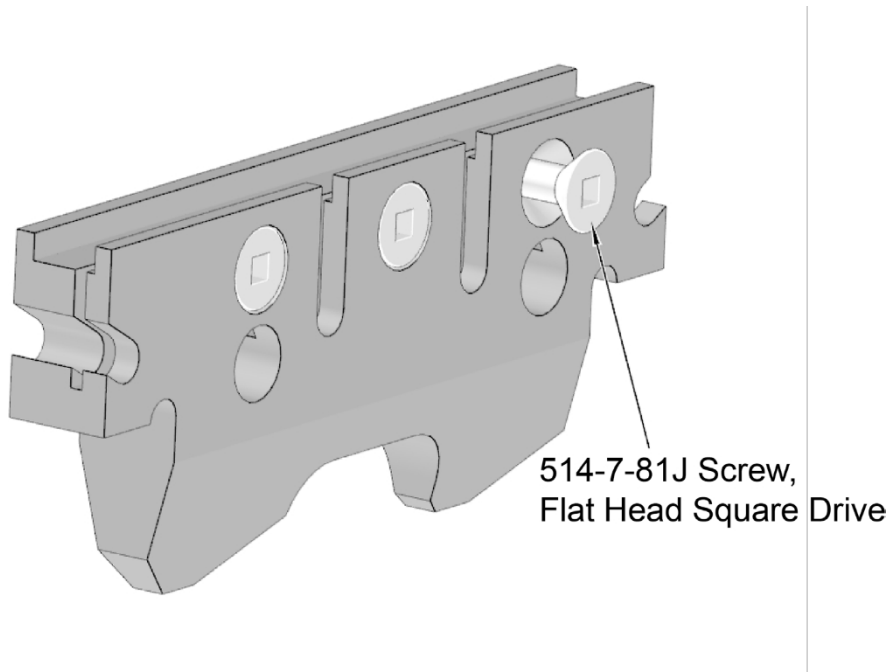
	7,925 Pietre		5.08 Pietre	
	Min	Massimo	Min	Massimo
514-9-6J	75.92	87.73	70.23	82.04
514-9-6A	80.39	92.20	74.70	86.51
514-9-6B	86.74	98.55	81.05	92.86
514-9-6C	93.09	104.90	87.40	99.21
514-9-6D	99.44	111.25	93.75	105.56
514-9-6E	105.79	117.60	100.10	111.91
514-9-6F	112.14	123.95	106.45	118.26
514-9-6G	118.49	130.30	112.80	124.61
514-9-6H	124.84	136.65	119.15	130.96
514-9-6K	131.19	143.00	125.50	137.31
514-9-6L	137.54	149.35	131.85	143.66
514-9-6M	143.89	155.70	138.20	150.01
514-9-6N	150.24	162.05	144.55	156.36
514-9-6P	156.59	168.40	150.90	162.71
514-9-6Q	162.94	174.75	157.25	169.06
514-9-6R	169.29	181.10	163.60	175.41
514-9-6S	175.64	187.45	169.95	181.76

Diametro (nuove spazzole)

	0,550 Spazzole		0,395 Spazzole	
	Min	Massimo	Min	Massimo
514-9-6J	3.47	3.93	3.16	3.62
514-9-6A	3.64	4.11	3.33	3.80
514-9-6B	3.89	4.36	3.58	4.05
514-9-6C	4.14	4.61	3.83	4.30
514-9-6D	4.39	4.86	4.08	4.55
514-9-6E	4.64	5.11	4.33	4.80
514-9-6F	4.89	5.36	4.58	5.05
514-9-6G	5.14	5.61	4.83	5.30
514-9-6H	5.39	5.86	5.08	5.55
514-9-6K	5.64	6.11	5.33	5.80
514-9-6L	5.89	6.36	5.58	6.05
514-9-6M	6.14	6.61	5.83	6.30
514-9-6N	6.39	6.86	6.08	6.55
514-9-6P	6.64	7.11	6.33	6.80
514-9-6Q	6.89	7.36	6.58	7.05
514-9-6R	7.14	7.61	6.83	7.30
514-9-6S	7.39	7.86	7.08	7.55

Diametro (spazzole nuove) (metrico)

	13.970 Spazzole		10.033 Spazzole	
	Min	Massimo	Min	Massimo
514-9-6J	88.01	99.82	80.14	91.95
514-9-6A	92.48	104.29	84.61	96.42
514-9-6B	98.83	110.64	90.96	102.77
514-9-6C	105.18	116.99	97.31	109.12
514-9-6D	111.53	123.34	103.66	115.47
514-9-6E	117.88	129.69	110.01	121.82
514-9-6F	124.23	136.04	116.36	128.17
514-9-6G	130.58	142.39	122.71	134.52
514-9-6H	136.93	148.74	129.06	140.87
514-9-6K	143.28	155.09	135.41	147.22
514-9-6L	149.63	161.44	141.76	153.57
514-9-6M	155.98	167.79	148.11	159.92
514-9-6N	162.33	174.14	154.46	166.27
514-9-6P	168.68	180.49	160.81	172.62
514-9-6Q	175.03	186.84	167.16	178.97
514-9-6R	181.38	193.19	173.51	185.32
514-9-6S	187.73	199.54	179.86	191.67

Pietre diamantate, altezza .312" (7,90 mm), set di 4 pietre
514-9-14F Pietre diamantate, grana

80 lunghe 3" (76 mm) set di 4, 90Ra (2,25um), asportazione .004-.007/min.

514-9-14R Pietre diamantate, grana 80

Set di 4 pezzi lunghi 3 1/2" (89 mm), 90Ra (2,25um), asportazione di materiale .004-.007/min. (.102 - .178 mm)

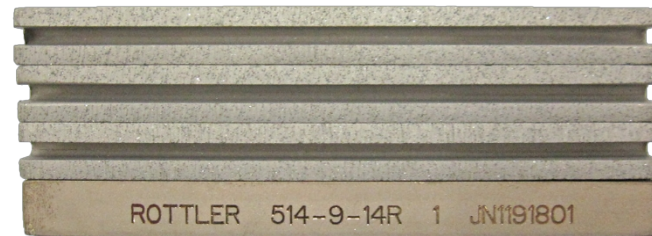
514-9-21R Pietre diamantate, grana 80

Set di 4" (102 mm) di lunghezza, 90 Ra (2,25um)

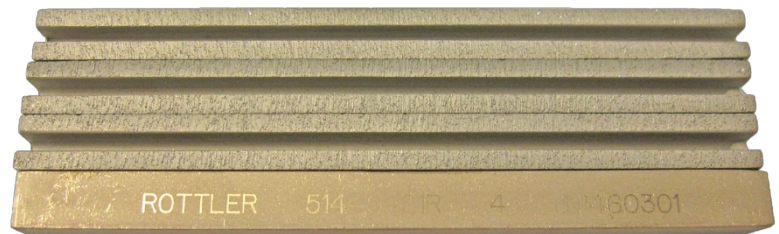
514-9-14W Pietre diamantate, grana 140/170

Set di 4 pezzi lunghi 3" (76 mm), 50-75Ra (1,25 - 1,875um)

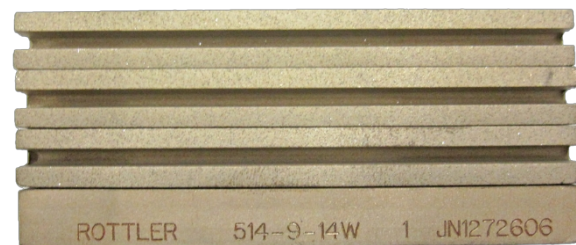

514-9-21W Pietre diamantate, grana 140/170

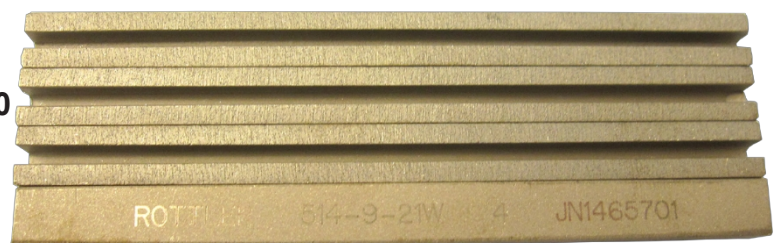
Set di 4" (102 mm), 50-75 Ra, (1,25 - 1,875um)

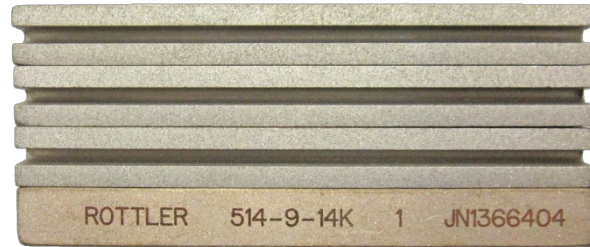

514-9-14K Pietre diamantate, grana 170/200

3 (76 mm) set lungo di 4, 45-60Ra (1,125 - 1,5um)

514-9-14M Pietre diamantate, grana 170/200

Set di 4 pezzi lunghi 3 1/2" (89 mm), 45-60Ra (1,125 - 1,5um)

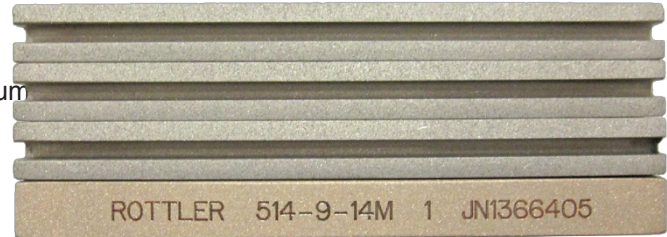
514-9-21M Pietre diamantate, grana 170/200

Set di 4" (102 mm), 45-60 Ra, (1,125 - 1,5um)

514-9-14J Pietre diamantate, grana 270/325

Set di 4 pezzi lunghi 3" (76 mm), 35-45Ra (.875 - 1.125um)

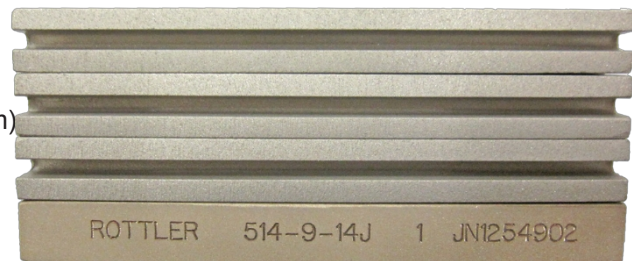
514-9-14T Pietre diamantate, grana 270/325

Set di 4 pezzi lunghi 3 1/2" (89 mm), 35-45Ra (.875 - 1.125um)



514-9-14Z Pietre diamantate, grana 270/325
Set di 4" (102 mm), 35-45Ra (.875 - 1.125um)



514-9-14E Pietre diamantate, grana 325/400
Set di 4 pezzi da 3" (76 mm), 24-30Ra (.6 - .75um)



514-9-14Q Pietre diamantate, grana 325/400
Set di 4 pezzi lunghi 3 1/2" (89 mm), 24-30Ra (.6 - .75um)

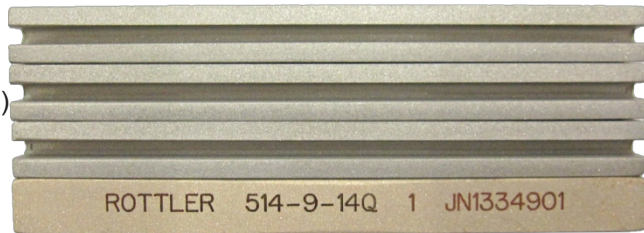

514-9-14X Pietre diamantate, grana 325/400
Set di 4" (102 mm), 24-30Ra (.6 - .75um)



514-9-14V Pietre diamantate, grana 500
Set di 4 pezzi da 3" (76 mm), 15-19Ra (.375 - .475um)

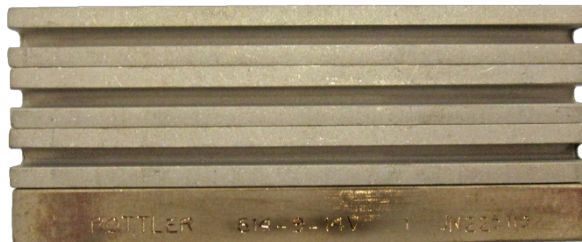

514-9-14C Pietre diamantate, grana 325/400

Set di 4 pezzi da 3" (76 mm), 18-22Ra (.45 - .55um)

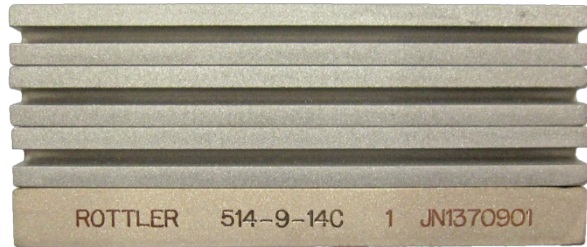

514-9-14P Pietre diamantate, grana 500

Set di 4 pezzi lunghi 3-1/2" (89 mm), 18-22Ra (.45 - .55um)

514-9-14D Pietre diamantate, grana
325/400 Set di 4 pietre lunghe 3" (76 mm), 18-22Ra (.45 - .55um) Richieste speciali per fori di diametro inferiore a 2,990" (75,94 mm) Altezza .200" (5,1 mm)

514-9-14U Pietre diamantate, grana 500

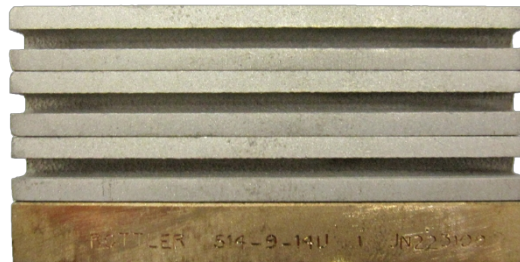
Set di 4 pezzi da 2 1/2" (64 mm), 18-22Ra (.45 - .55um)

514-9-14L Pietre diamantate, grana 550

Set di 4 pezzi da 3" (76 mm), 15-19Ra (.375 - .475um)



514-9-14N Pietre diamantate, grana 550

Set di 4 pezzi lunghi 3 1/2" (89 mm), 15-19Ra (.375 - .475)



514-9-14G Pietre diamantate, grana 600

Set di 4 da 3" (76 mm), 8-12Ra (.2 - .3um)



514-9-14S Pietre diamantate, grana 600

Set di 4 pezzi lunghi 3 1/2" (89 mm), 8-12Ra (.2 - .3um)



514-9-21G Pietre diamantate, grana 800

Set di 4 pezzi lunghi 3" (76 mm)



514-9-21H Pietre diamantate, grana 1000

Set di 4 pezzi lunghi 3" (76 mm)



514-9-21J Pietre diamantate, grana 1200

Set di 4 pezzi lunghi 3" (76 mm)

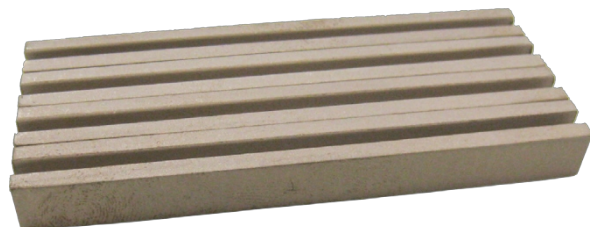

Pietre in CBN per la superfinitura con le teste di affilatura Rottler Precision a 4 e 6 pietre
514-9-35C Pietre CBN, grana 320

Set di 4 pezzi lunghi 3" (76 mm), per una super finitura

514-9-35D Pietre CBN, grana 400

Set di 4 pezzi lunghi 3" (76 mm), per una super finitura

514-9-35B Pietre CBN, grana 600

Set di 4 pezzi lunghi 3" (76 mm), per una super finitura

514-9-35E Pietre CBN, grana 500

Set di 4 pezzi lunghi 3" (76 mm), per una super finitura

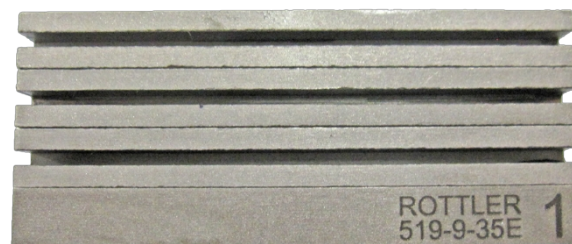

Spazzole per la finitura del piano con le teste di levigatura Rottler Precision 4 e 6 Stone Holder**514-9-14H Spazzole, per finitura a platea**

Altezza .550" (14 mm), lunghezza 3 1/2" (89 mm). Set di 4

Richiede un supporto per pietra di una o due dimensioni inferiori rispetto alla pietra diamantata di altezza .312" (7,90 mm).

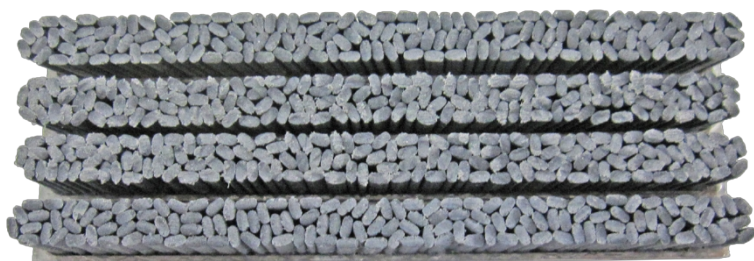
**514-9-14Y Spazzole, per finitura a platea**

Altezza .395" (10 mm), lunghezza 3 1/2" (89 mm). Set di 4

Richiede un portapietra della stessa misura o di una misura inferiore rispetto alla pietra diamantata di altezza .312" (7,90 mm).



Pietre speciali per la finitura di cilindri in alluminio e silicone

(Fare riferimento al bollettino n. 284) Richiede teste di affilatura Rottler Precision a 4 o 6 pietre.

514-9-18P Diamanti speciali con finitura rossa

Per il dimensionamento finale (set di 4)



514-9-18N Silicone Abrasivo Pietre di esposizione

Per la rimozione dell'alluminio (set di 4)



514-9-21 Pad di feltro per lucidatura

Da utilizzare con la pasta siliconica 514-9-21F. (set di 4)



514-9-21F Pasta di silicone

Da utilizzare con i feltrini di lucidatura 514-9-21



Testa di affilatura speciale a

doppio stadio 514-9M Testa di affilatura, parti a doppio stadio

L'immagine di montaggio e l'elenco delle parti non sono al momento disponibili.

Visitare la scheda di assistenza della nostra pagina web all'indirizzo www.rottlermfg.com o contattare il servizio di assistenza di fabbrica Rottler all'indirizzo service@rottlermfg.com per assistenza e richiesta di assistenza.

Potete anche chiamare Rottler al numero 1-800-452-0534 o 1-253-872-7050.

Assicurarsi di avere a disposizione il modello e il numero di serie della macchina quando si contatta Rottler per l'assistenza.

Testa di affilatura speciale 514-9M a doppio stadio, pietre diamantate, set da 6

110-162 R Pietre diamantate a doppio stadio

Alto 0,0781" (19,83 mm), (grana 325/400) Set di 6 pezzi



110-163 R Pietre diamantate a doppio stadio

Alto 0,859" (22,73 mm), (grana 325/400) Set di 6 pezzi

Image Currently Unavailable

110-163 R-01 Pietre diamantate a doppio stadio

Alto .859" (22,73MM), (grana 140/170)

Foro da 3,865", set di 6 pezzi

Image Currently Unavailable

110-163 R-03 Pietre diamantate a doppio stadio

Alto .859" (22,73MM), grana 600
Foro da 3,865", set di 6 pezzi



Image Currently Unavailable

110-164 R Pietre diamantate a doppio stadio

Alto 0,937" (23,80 mm), (grana 325/400) Set di 6 pezzi



Image Currently Unavailable

110-164 R-01 Pietre diamantate a doppio stadio

Alto .937" (23,80MM), (grana 140/170)
Alesaggio da 4,110", set da 6



Image Currently Unavailable

110-164 R-03 Pietre diamantate a doppio stadio

Alto .937" (23,80MM), grana 60
Alesaggio da 4,110", set da 6



Image Currently Unavailable

Set di spazzole speciali con testa affilata a doppio stadio

124-24 Set di spazzole, testa di affilatura a doppio stadio
Alto .781 (19,84MM) Set di 4 pezzi

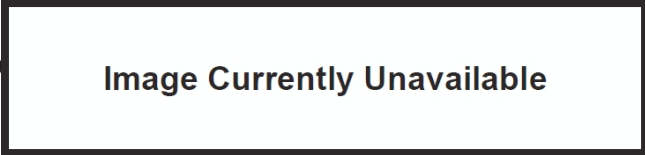

124-25 Set di spazzole, testa di affilatura a doppio stadio
.859 Alto (21.82MM) Set di 4

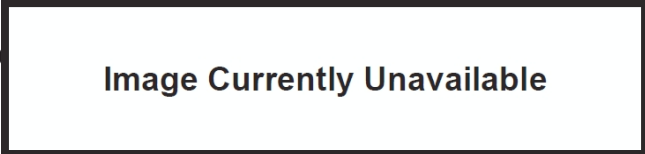

124-26 Set di spazzole, testa di affilatura a doppio stadio
Alto .937 (23,80MM) Set di 4 pezzi

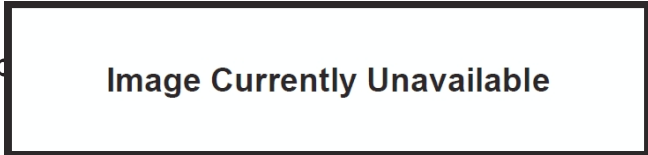

Testa di affilatura speciale a singolo**stadio, 12 pietre 514-9N Testa di affilatura, parti a singolo stadio**

L'immagine di montaggio e l'elenco delle parti non sono al momento disponibili.

Visitare la scheda di assistenza della nostra pagina web all'indirizzo www.rottlermfg.com o inviare una richiesta di assistenza service@rottlermfg.com per assistenza e richiesta di assistenza.

Potete anche chiamare Rottler al numero 1-800-452-0534 o 1-253-872-7050.

Assicurarsi di avere a disposizione il modello e il numero di serie della macchina quando si contatta Rottler per l'assistenza.

110-171-01 Pietre diamantate a stadio singolo

Alto .0781" (19,83MM), grana 600 Set di 12 pezzi

**110-171-02 Pietre diamantate a stadio singolo**

Alto .0781" (19,83MM), grana 1200, set di 12 pezzi

**110-171-03 Pietre diamantate a stadio singolo**

Alto .0781" (19,83MM), (grana 325/400) - Set di 12 pezzi



Apparecchiatura di misura opzionale

201 Mitutoyo Surface Tester Surftest 201

Venduto solo come unità completa.



514-8-27 Gruppo scala e supporto per pietra (pollici) 514-8-

27F Gruppo scala e supporto per pietra (metrico)

Entrambi gli articoli sono venduti solo come gruppi completi.

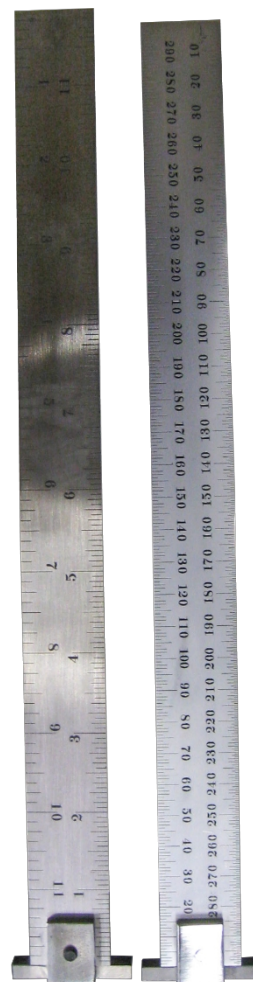

Telecamera e software per visualizzare l'angolo del boccaporto trasversale

514-14-29A Telecamera



514-14-29B Pacchetto software

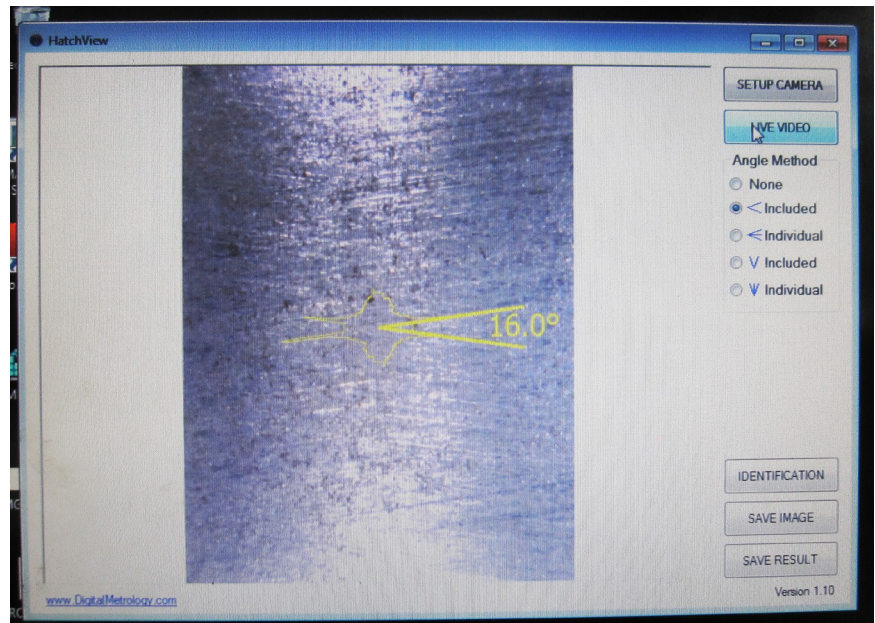

Parti dell'adattatore per cono a spillo 514-9V

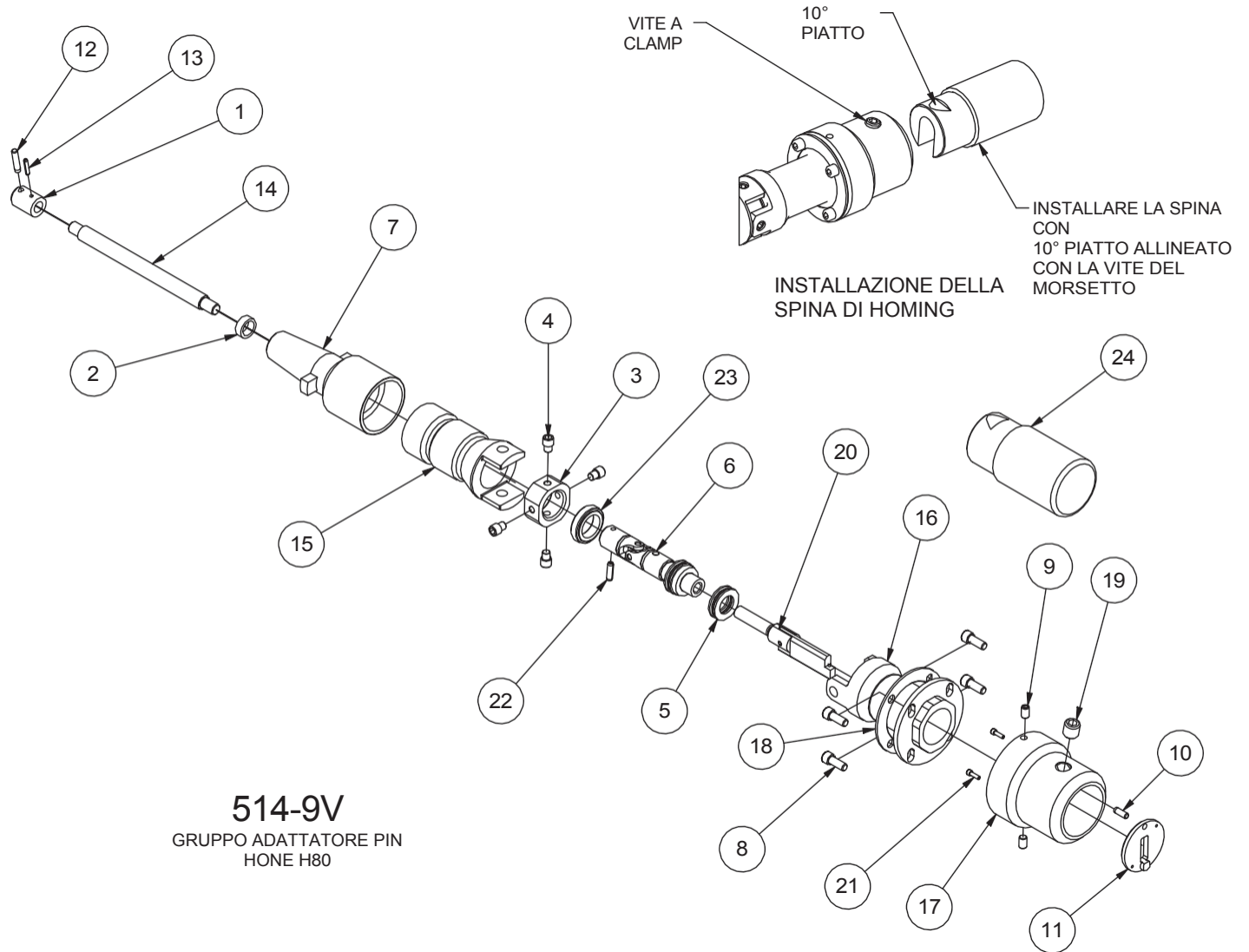

514-9V GRUPPO ADATTATORE PIN HONE - H80			
ARTICOL O	QTÀ	NUMERO DI PARTE	DESCRIZIONE
1	1	514-6-44	ACCOPPIAMENTO GUIDATO - AFFILATURA #2
2	1	514-7-80T	BOCCOLA OIL LITE
3	1	514-10-6	PERNO DI BLOCCAGGIO TESTA DI AFFILATURA UNIVERSALE PERCISIONE JUNIOR
4	4	514-10-10	VITE PIVOT
5	1	514-7-82F	RONDELLA SFERICA
6	1	514-10-5B	GRUPPO GIUNTO A U - ADATTATORE PERNO - H80
7	1	514-13-49	CONICITÀ DELL'INTERRUTTORE KWIK
8	4	MF-13	S.H.C.S.1/4 - 20 UNC - 5/8
9	2	514-10-1E	VITE DI REGOLAZIONE A PUNTA PIATTA 1/4-28UNF x 3/8" LUNGA
10	1	MF-196	3/16" x 1/2" LG. PERNO DI SOTTOTESTO
11	1	514-10-3D	PIASTRA DI SUPPORTO, GRUPPO ADATTATORE PER CONO A SPILLO
12	1	MF-198A	Spina da 3/16 x 7/8
13	1	MF-218	1/8 x 5/8 Perno di rotolamento
14	1	514-10-20C	ALBERO DI REGOLAZIONE - GRUPPO ADATTATORE PER CONO A SPILLO
15	1	514-10-20D	TUBO DI AZIONAMENTO DELLA FORCELLA, ADATTATORE PER CONO A SPILLO - H75
16	1	514-10-1B	CORPO SUPERIORE, GRUPPO ADATTATORE PER CONO A SPILLO - H80
17	1	514-10-1C	CORPO INFERIORE, GRUPPO ADATTATORE PER CONO A SPILLO - H80
18	1	514-10-1D	PIASTRA DI SERRAGGIO, GRUPPO ADATTATORE PER CONO A SPILLO - H80
19	1	6855P	VITE DI STAFFETTA A PUNTA PIATTA 1/2-13UNC x 1/2" LUNGA
20	1	514-10-3E	GRUPPO ATTUATORE, GRUPPO ADATTATORE PIN HONE - H80
21	2	MF-84D	4-40UNC x 3/8" LG. S.H.C.S.
22	1	MF-223C	3/16" X 5/8" LG. PERNO DI ROTOLO
23	1	514-10-1F	DADO, CUSCINETTO REGGISPINTA - ADATTATORE PER CONO A SPILLO - H80
24	1	514-10-1G	SPINA HOMING, ADATTATORE PIN HONE - H85

Sistema di protezione contro l'arresto di sicurezza

514-14-99 Barriera luminosa laser
Venduto solo come assemblaggio completo.

