

# **ROTTLER**

## **H85AX CNC**

## **HONING MACHINE**

## **MACHINE INSTALLATION MANUAL**





# **PARTS ORDERING**

For optional equipment catalogs, please visit <https://www.rottlermfg.com/documentation.php>

For fastest service ordering parts or equipment, contact us via e-mail with the information below. For customers within the U.S., send emails to [parts@rottlermfg.com](mailto:parts@rottlermfg.com), for customers outside of the U.S., use [intlparts@rottlermfg.com](mailto:intlparts@rottlermfg.com)

Have the following information on hand to expedite the ordering process:

1. Your name, business name, and contact number
2. Customer number, or your billing address if you do not have a customer number
3. Shipping address if different from the billing address
4. Machine model and serial number
5. Part number and description of the item(s) to order
6. Preferred method of shipment

For customers outside of the U.S. requiring faster service, contact your local distributor.

In some cases, you may be requested to send a photo of the part you are ordering if it is a replacement part or does not appear in our database.

If you are unsure which part you need to order, contact our service department, and ask to speak to one of our service consultants. They will assist you in determining which part(s) you require.

**THERE IS A MINIMUM ORDER OF \$25.00**

# **MANUAL SECTIONS**

**INTRODUCTION**

**INSTALLATION**

# INTRODUCTION

## Contents

<b>INTRODUCTION .....</b>	<b>12</b>
<b>Description .....</b>	<b>12</b>
<b>Disclaimer .....</b>	<b>13</b>
<b>Limited Warranty .....</b>	<b>13</b>
<b>Online Documentation Access .....</b>	<b>14</b>
<b>Specifications .....</b>	<b>16</b>

## INTRODUCTION

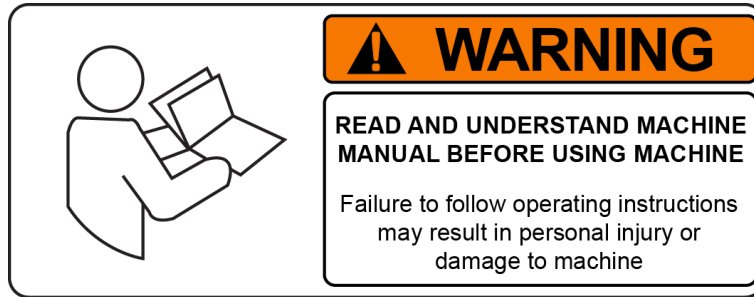

**READ THE SAFETY CHAPTER BEFORE INSTALLING MACHINE. THOROUGHLY UNDERSTAND ALL SAFETY ISSUES BEFORE OPERATING MACHINE.**

### **ATTENTION OWNER/BUSINESS MANAGER**

**To validate the warranty on your new Rottler machine, please be sure to sign and complete the “Installation Report” located in the Installation Chapter of this manual.**

We suggest that the new user of the H85AX read the CONTROL DEFINITIONS to get an idea how the machine operates.

The Operating Instructions chapter should be read in order to familiarize the user with the actual button pushing sequences required to carry out a job. These chapters in the manual should be considered an introduction. As the operators of the H85AX series machines gain experience with using the different functions of the machine, complicated setups and programs will make more sense.

The rest of the manual contains information and part number reference on fixtures, cutting tools, and machine maintenance. The operator should read and become familiar with these areas as well.

#### **Description**

The model H85AX Honing Machine is a wet, complete cylinder block and general purpose-honing machine

A Windows based touch screen panel provides easy and convenient control of the H85AX. Block programs can be created and stored to memory for later recall, providing a quick set up for honing

common blocks. All preferences such as dwell setting, cross hatch angle, and honing loads are automatically set up when a block program is selected at time of machine set-up.

The support carriage is mounted on linear rails to provide simple and easy hole-to-hole setup.

Convenient devices are provided to properly control honing operations and provide easy handling.

Fixtures are available for doing a large variety of engine types. Special fixtures and tooling for doing large industrial engine sleeves is also available.

A coolant tank is located under the main splash tank and a coolant pump is located behind the machine. A button is provided on the control panel to operate the coolant system.

## **Disclaimer**

The H85AX Manual (henceforth to be referred to as the “Manual”) is proprietary to Rottler Manufacturing LLC. (“Rottler Manufacturing”) and no ownership rights are hereby transferred. No part of the Manual shall be used, reproduced, translated, converted, adapted, stored in a retrieval system, communicated or transmitted by any means, for any commercial purpose, including without limitation, sale, resale, license, rental or lease, without the prior express written consent of Rottler Manufacturing.

Rottler Manufacturing does not make any representations, warranties or guarantees, express or implied, as to the accuracy or completeness of the Manual. Users must be aware that updates and amendments will be made from time to time to the Manual. It is the user’s responsibility to determine whether there have been any such updates or amendments. Neither Rottler Manufacturing nor any of its directors, officers, employees or agents shall not be liable in any manner whatsoever to any person for any loss, damage, injury, liability, cost or expense of any nature, including without limitation incidental, special, direct or consequential damages arising out of or in connection with the use of the Manual.

Rottler Manufacturing and its employees or representatives are not responsible for any information regarding final specifications of any workpiece that is created as a final product when using Rottler equipment. It is the responsibility of the end user of Rottler equipment to determine the final dimensions and finishes of the workpiece that they are working on. Any information regarding final dimensions and finishes that appears in any Rottler literature or that is expressed by anyone representing Rottler is to be regarded as general information to help with the demonstration of or for operator training of Rottler equipment.

## **Limited Warranty**

Rottler Manufacturing Company Model H85AX parts and equipment is warranted as to materials and workmanship. This limited warranty remains in effect for one year from the date of installation or two years from the date of the original shipment from Rottler or whichever date occurs first. This only applies if the machine is owned and operated by the original purchaser and is operated and maintained as per the instructions in the manual. A machine is warranted only if the Installation Report has been properly executed by a certified installation person and received by Rottler at the time of actual installation.

The products are warranted upon delivery to conform to their published specifications and to be free from defects in material and workmanship under normal use for a period of one year from shipment. Should a product not be as warranted, Rottler sole obligation shall be, at its option, to repair, correct or replace the

product or to refund the amounts paid for the Product upon its return to a location designated by Rottler. No warranty shall extend to rapid wear Products (including tooling) or to Products which have been subject to misuse (including any use contrary to Rottler instructions), neglect, accident (including during shipment), improper handling or installation, or subject to any modification, repair or service not certified by Rottler. Rottler shall not be liable for any consequential, direct or indirect damages or for any other injury or loss. Buyer waives any right, beyond the foregoing warranty, to make a claim against Rottler. No warranty is provided for any Products not paid in full.

Merchandise cannot be returned to Rottler without prior approval. Customer must contact the Parts Department to get approval and to be issued a Return Goods Authorization number (**RGR#**). Merchandise authorized for return must be returned prepaid. If merchandise is returned with shipping charges collect, the actual amount of these charges may be deducted from any credit which may be due the customer. The **RGR #** assigned by the Parts Department should be written on the shipping label and must appear on a copy of the invoice(s) covering the original shipment. This invoice copy must be included in the box with the parts. Shipment must contain **ONLY** those items on the **RGR** as approved for return. Merchandise must be received within 10 days of the date of **RGR** or the **RGR** will be canceled. All returned merchandise may be subject to a 20% restocking fee on under \$1,000.00 amount or 10% on any items over \$1,000.00. Parts or tooling over 30 days old are considered as customer property and can only be returned with prior approval from Rottler Corporation Management.

The issuance of a **RGR DOES NOT** guarantee credit - it is only authorization for the return of the goods. Credit for return merchandise is at the sole discretion of Rottler. Credit will be issued only after inspection of returned goods.

Tools proven to be defective within the warranty period will be repaired or replaced at the factory's option. We accept no responsibility for defects caused by external damage, wear, abuse, or misuse, nor do we accept any obligation to provide compensation for direct or indirect costs in connection with cases covered by the warranty.

### **Online Documentation Access**

Online documentation for machines and optional equipment can be accessed at the Rottler website. To access documentation open your browser and navigate to <https://www.rottlermfg.com>.

Scroll to the bottom of the page and under the Owner Resources title click the type of documentation you want to access.



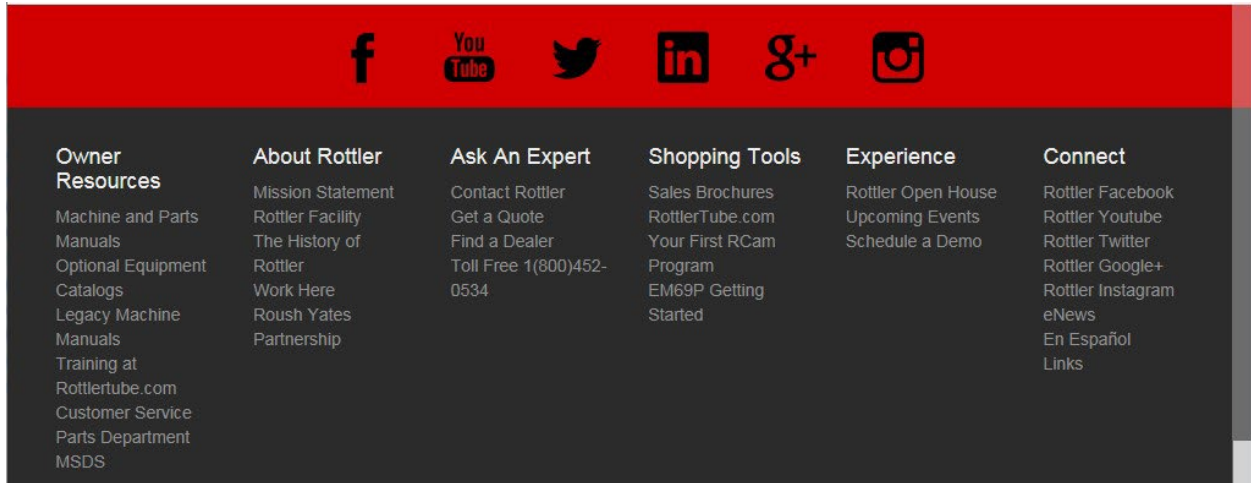

If a log in window pops up asking for user name and password fill in the blanks as shown.

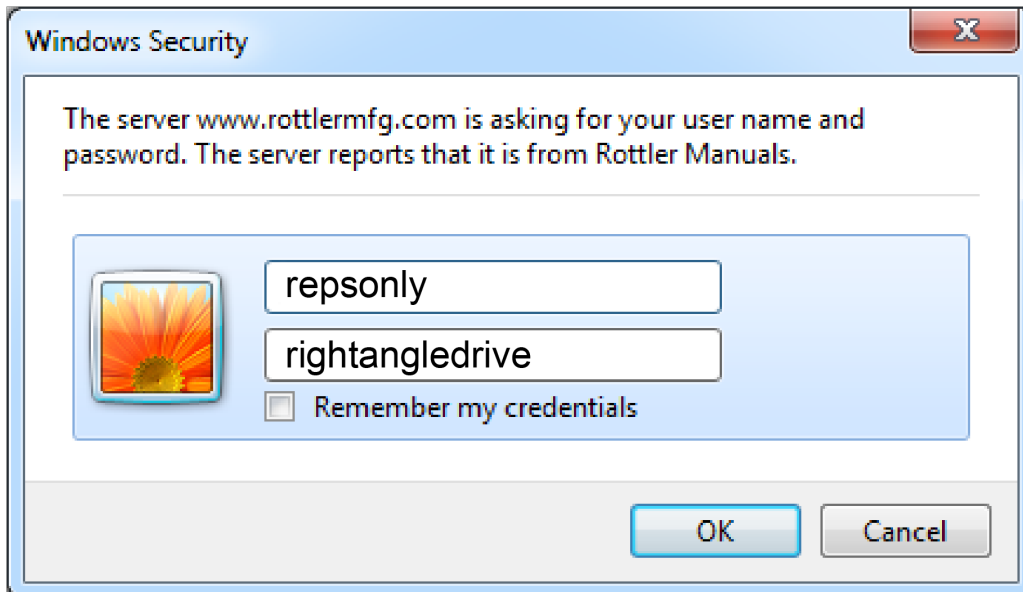

## Specifications

<b>MADE IN U.S.A.</b>	<b>American</b>	<b>Metric</b>
Diameter Range (with Rottler Hone Heads)	1.69" - 7.38"	43mm – 187.45mm
Spindle/Hone Head Rotation Speed	1 to 400 RPM	1 - 400 RPM
Torque at Hone Head	44 ft.lbs	60NM
Spindle Motor - Torque	15 ft.lbs	20NM
Spindle Motor - Power	3.7HP	2.77 Kw
Stroker Motor - Torque	88.5in.lbs	10NM
Stroker Motor - Power	1.94HP	1.45KW
Stroke System - Acceleration	250 in/sec <sup>2</sup>	6.35m/sec <sup>2</sup>
Spindle Stroke - Speed	0-1500-ipm	0-38-m/min
Stroke Length - Vertical Travel (Z Axis)	19"	483mm
Length of Cylinder to be Honed	17"	432mm
Workpiece Capacity - Length	55"	1400mm
Workhead - Horizontal Travel (X Axis)	38"	965mm
Coolant Capacity	70 Gallons	265 Liters
Dimensions - Floor Space Requirements	48"D X 75"W x 86"H	1.2mD X 1.1.9mW X 2.2mH
Dimensions - Shipping	67"D X 87"W X 90"H	1.70mD X 2.21mW X 2.29mH
Weight - Shipping (excluding optional equipment)	3400 lbs	1540 kg
Electrical Requirements	208-240V, 30A, 50/60Hz, 3Ph	
Paint Color Code	RAL9002 (Grey White)	

*Specifications and design subject to change without notice.*

# INSTALLATION

## Contents

<b>INSTALLATION REPORT .....</b>	<b>2-2</b>
<b>Machine Dimensions .....</b>	<b>2-8</b>
<b>Machine Working Clearances .....</b>	<b>2-9</b>
<b>Optional Anchor Bolt Locations .....</b>	<b>2-10</b>
<b>Work Envelope Dimensions .....</b>	<b>2-11</b>
<b>Side View .....</b>	<b>2-11</b>
<b>Top View .....</b>	<b>2-12</b>
<b>Installation Procedure .....</b>	<b>2-13</b>
<b>Location .....</b>	<b>2-13</b>
<b>Unpacking .....</b>	<b>2-13</b>
<b>Leveling .....</b>	<b>2-13</b>
<b>Coolant .....</b>	<b>2-13</b>
<b>Power Supply .....</b>	<b>2-14</b>
<b>Grounding .....</b>	<b>2-15</b>
<b>Transformer Connections .....</b>	<b>2-15</b>
<b>Creating a Skype Account .....</b>	<b>2-16</b>

## **ATTENTION OWNER/BUSINESS MANAGER**

**To validate the warranty on your new Rottler machine, please be sure to sign the installation report after the installation technician has installed the machine and verified the machine is operating correctly and given the operators operation and maintenance training.**

**Thank you for your cooperation and the opportunity to be of service to you.**

**ROTTLER MANUFACTURING**



**INSTALLATION REPORT**

H85 SERIES

REV 010924

**OFFICE USE ONLY**

Route to:

Orders Notified \_\_\_\_\_ Eng Mgr \_\_\_\_\_ Svc Mgr \_\_\_\_\_ Assem Mgr \_\_\_\_\_ Andy \_\_\_\_\_ Svc Filing \_\_\_\_\_

Warranty Exp Date \_\_\_\_\_

**ROTTLER MANUFACTURING MUST HAVE THIS REPORT RETURNED TO PROPERLY QUALIFY WARRANTY ON EQUIPMENT**

Customer: \_\_\_\_\_ Address: \_\_\_\_\_

City: \_\_\_\_\_ State: \_\_\_\_\_ Zip: \_\_\_\_\_ Phone: \_\_\_\_\_

Country: \_\_\_\_\_

Machine Model: \_\_\_\_\_ Serial Number: \_\_\_\_\_

Representative: \_\_\_\_\_ **MACHINE INSTALLATION:** Electrical information MUST

be complete to validate this report.

**Customer responsibility prior to the arrival of Rottler Sales/Service technician. Please Initial each item when it is completed.**

**CAUTION** **VERY IMPORTANT:** Modern design machines contain electronic low voltage circuitry that provides great advantages and a better machine life. BUT, you must have an excellent, stable, power supply along with a good earth ground. If not, electrical noise problems are likely to interfere with machine operation unexpectedly.

**Customer is responsible for providing electricity to machine in a manner that meets the local electrical code requirements.**

- \_\_\_\_\_ Remove machine from truck. Weight: 2,500 lbs.
- \_\_\_\_\_ Provide solid foundation for machine.
- \_\_\_\_\_ Remove fixturing and misc. from machine and clean.
- \_\_\_\_\_ Install machine on foundation with jack pads under jacking bolts.
- \_\_\_\_\_ Level machine. When level all leveling bolts should have equal pressure on them.
- \_\_\_\_\_ This machine requires between 208 and 240 Volts AC, Three Phase, 50/60 Hz power supply.

**IMPORTANT** **If this machine is being installed in a location without 3 phase power, follow the single phase wiring hookup shown in the installation section of the manual.**

\_\_\_\_\_ Measure the incoming voltage between L1 and L2, L2 and L3, L1 and L3. Measure the incoming AC voltage at least twice during installation.

L1 to L2 \_\_\_\_\_ VAC      L2 to L3 \_\_\_\_\_ VAC      L1 to L3 \_\_\_\_\_ VAC

L1 to L2 \_\_\_\_\_ VAC      L2 to L3 \_\_\_\_\_ VAC      L1 to L3 \_\_\_\_\_ VAC

\_\_\_\_\_ This machine should have an external breaker rated at 25 Amps, continuous draw.

\_\_\_\_\_ Measure each leg of the incoming supply to ground. Sometimes you may find a “high” leg to ground. When this happens make sure the high leg is disconnected and the machine is hooked up in single phase.

L1 to ground \_\_\_\_\_ VAC    L2 to ground \_\_\_\_\_ VAC    L3 to ground \_\_\_\_\_ VAC



### CAUTION

Neutral and machine ground are not the same thing. You should measure an open circuit between Neutral and ground.



### CAUTION

**IF VOLTAGE IS OUTSIDE THE CORRECT RANGE AT ANY TIME THE MACHINE WILL NOT OPERATE PROPERLY AND MAY BE DAMAGED.**

\_\_\_\_\_ Customer should attempt to have junk work piece available.

\_\_\_\_\_ Make sure coolant will be available for set up.

\_\_\_\_\_ Have the operator read through the operation manual before training begins. This will help him be familiar with the button pushing sequences. Have the operator read through the manual again after training and some of the sequences will make more sense.

\_\_\_\_\_ Clean any rust inhibitor from the machine surfaces

\_\_\_\_\_ Make sure that an Internet connection is available at the machine.

## The following is the Rottler Sales/Service technician’s responsibility

### MACHINE START-UP

\_\_\_\_\_ **BEFORE** turning power on to the machine. Check all wires for security by using the correct screw driver and turning CW until movement stops. Stranded wire can “spread” slightly from vibration during transport.

\_\_\_\_\_ Install electrical component covers inside the electrical enclosure with fasteners provided.

\_\_\_\_\_ The system is protected by fuses and circuit breakers located in the electrical enclosure. Show customer where they are located and confirm that spare fuses were shipped with machine.



### CAUTION

When starting the machine for the first time, it may move out of control. Make sure all hands are clear of machine parts. Be ready to press the Emergency Stop button if needed.

Stop button if needed.

\_\_\_\_\_ Explain the coolant filtration system and necessity of maintenance to that system.

\_\_\_\_\_ Explain to the customer the injection oiler operation. The timer is controlled by the computer.

\_\_\_\_\_ Show the customer where the reservoir is located and explain what type of oil is required.

\_\_\_\_\_ Turn Main power on at the power switch located on the electrical enclosure.

\_\_\_\_\_ If any of the fuses blow, replace them, then call factory if further assistance is needed.

\_\_\_\_\_ If any of the circuit breakers “trip”, reset and call factory for possible trouble shooting.

\_\_\_\_\_ If machine moves out of control, turn power off and contact factory for help in trouble shooting.

\_\_\_\_\_ Install and test the Internet connection to the machine. DO NOT download any updates unless instructed to do so by Rottler.

\_\_\_\_\_ Check oil lines to make sure they are fully primed. On machines with enclosure the back access panel will have to be removed. If oil lines are not fully primed with oil, run the manual priming procedure as described in maintenance section of the manual.

### MACHINE MOVEMENTS

\_\_\_\_\_ Remove hone head from machine for the following procedures.

\_\_\_\_\_ Verify all machine movements are working correctly using the hand wheel.

\_\_\_\_\_ Verify all machine movements are working correctly using the jog buttons.

\_\_\_\_\_ Start spindle motor to verify correct direction of rotation.

### **INSTRUCTING THE OPERATOR:**

**Note: Rotter employees and representatives per company policy are not permitted to provide end user of Rottler equipment with any OEM specifications for the workpiece that is created by end user using Rottler equipment.**

#### **WARNING**

\_\_\_\_\_ Explain to the customer and operator that at NO time is there to be any software or hardware other than Windows Auto Update and Rottler installed on this machine. This includes screen savers, anti-virus software, and any hardware device that installs software on the machine. Installation of screen savers and anti-virus software can cause dangerous control problems. Any installation of software or hardware will void the warranty on the machine.

\_\_\_\_\_ Explain to the customer and operator that the machine should be hooked up to the Internet anytime it is on. The software on the machine will automatically connect to our server to send back useful information on machine status.

\_\_\_\_\_ Connect customer supplied Internet to the machine. Verify that the Internet is accessible from the machine.

\_\_\_\_\_ Once the machine has been fully setup and is ready for operation create a Skype account for the machine following the instructions in the Installation Section of the manual.

\_\_\_\_\_ Explain to the customer and the operator how the to log onto Skype and communicate with Rottler when needed.

#### **WARNING**

\_\_\_\_\_ Computer Viruses will cause the machine control system to become unstable. This may cause the machine to make uncontrolled moves which could create a dangerous environment for the machine operator.

#### **IMPORTANT**

\_\_\_\_\_ Refer to Chapter 4, Control Definitions of the Machine Manual, Section: Computer and Controller System Safety. Explain and discuss this section carefully with Owner/Manager/Operator and have them sign off. Failure to do so will result in the machine warranty being Null and Void.

---

Signature / Title

\_\_\_\_\_ Explain to the customer the importance of backing up the block profiles to a separate device. Any computer failure or possible operator input error can result in the loss of all block profiles that were created for the machine. Refer to Chapter 5 of the machine manual for detailed instructions on backing up and restoring block profiles.

\_\_\_\_\_ Using the operating manual as a guide explain the function of all buttons.

\_\_\_\_\_ Cycle all machine movements and supervise the handling of same by operator.

\_\_\_\_\_ Demonstrate the differences of Manual and Auto operation.

\_\_\_\_\_ If equipped with the auto rotate fixture explain how to set up and operate.

\_\_\_\_\_ Explain selecting correct riser blocks for the block to be honed.

\_\_\_\_\_ Fully explain the entire Auto Cycle.

\_\_\_\_\_ Explain the need to Home the machine each time the hone head is changed or removed and reinstalled on the spindle.

\_\_\_\_\_ Point out safety features to customer and operator. Do not push any buttons without thinking of safety first.

\_\_\_\_\_ Explain to the customer the proper way to turn the machine off when it is not in use. Do not leave the machine on overnight. It is important to close all programs followed by shutting down Windows before turning the main power switch off. Do not turn the main power switch off before shutting down Windows.

\_\_\_\_\_ The following is a checklist of information needed prior to setting up a job.

- Finish bore size, cross hatch angle, and finish.
- Bore length.
- Center to center dimension of cylinders.
- If the job is a V type block, the pan rail to crank line center dimension, and cylinder offset between cylinder banks.

\_\_\_\_\_ Demonstrate loading and roll over of V8 block.

\_\_\_\_\_ Demonstrate in-line block clamp system.

\_\_\_\_\_ Explain Optional block hold down arrangements.

\_\_\_\_\_ Supervise the operator loading, cycling and unloading the block.

\_\_\_\_\_ Develop the best block handling system you can for his shop.

\_\_\_\_\_ Consider a block coolant drain area.

\_\_\_\_\_ Examine several V8 blocks at the lower cylinder / bearing cap area and explain to the operator the necessity of setting the lower stop for maximum over stroke.

\_\_\_\_\_ Explain the ABSOLUTE requirement for complete relief below the cylinder, which may include hand grinding.

\_\_\_\_\_ Demonstrate removal and cleaning of cone in hone head.

\_\_\_\_\_ Explain all stone options as well as hone head options.

\_\_\_\_\_ Explain to the operator the methods for the fastest stock removal.

\_\_\_\_\_ Explain the cause and cure of bad geometry and improper stone cutting.

\_\_\_\_\_ Explain "breaking" the stones in.

\_\_\_\_\_ Demonstrate proper stone dressing (refer to manual).

\_\_\_\_\_ Explain the importance of maintaining the proper coolant mix.

\_\_\_\_\_ Explain the importance of keeping the coolant clean.

\_\_\_\_\_ Review the necessity of proper stone to coolant relationship.

\_\_\_\_\_ Again review the operator manual, including all safety and emergency stop procedures.

## MAINTENANCE SECTION

\_\_\_\_\_ Review machine lubrication per manual.

\_\_\_\_\_ Review coolant changing.

\_\_\_\_\_ Review filter paper changing.

\_\_\_\_\_ Review filling oil reservoir.

Rottler Manufacturing and its employees or representatives are not responsible for any information regarding final specifications of any workpiece that is created as a final product when using Rottler equipment. It is the responsibility of the end user of Rottler equipment to determine the final dimensions and finishes of the workpiece that they are working on. Any information regarding final dimensions and finishes that appears in any Rottler literature or that is expressed by anyone representing Rottler is to be regarded as general information to help with the demonstration of or for operator training of Rottler equipment.

Note: Rottler employees and representatives per company policy are not permitted to provide end user of Rottler equipment with any OEM specifications for the workpiece that is created by end user using Rottler equipment.





### Machine Dimensions

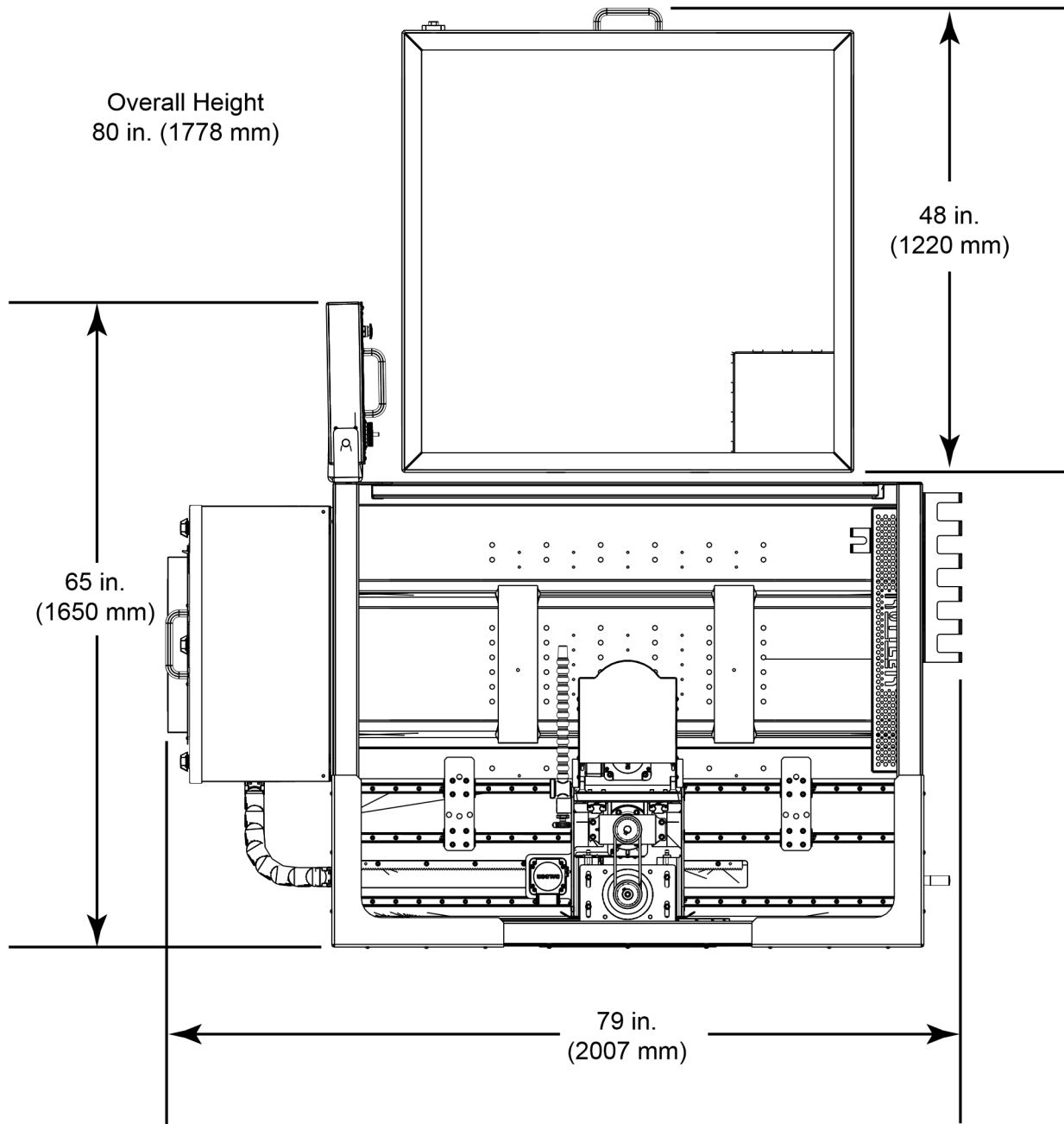

### Machine Working Clearances

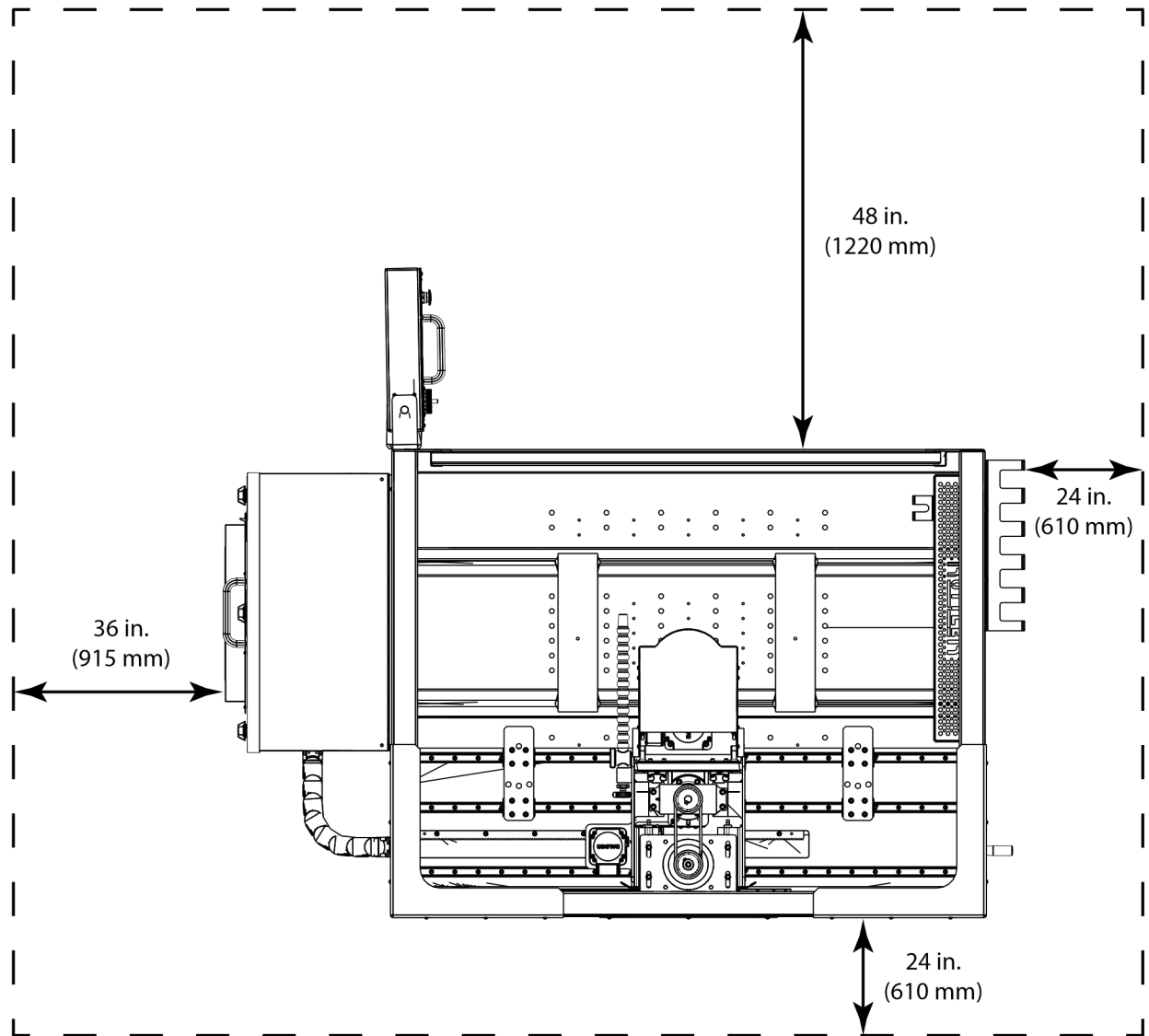

### Optional Anchor Bolt Locations

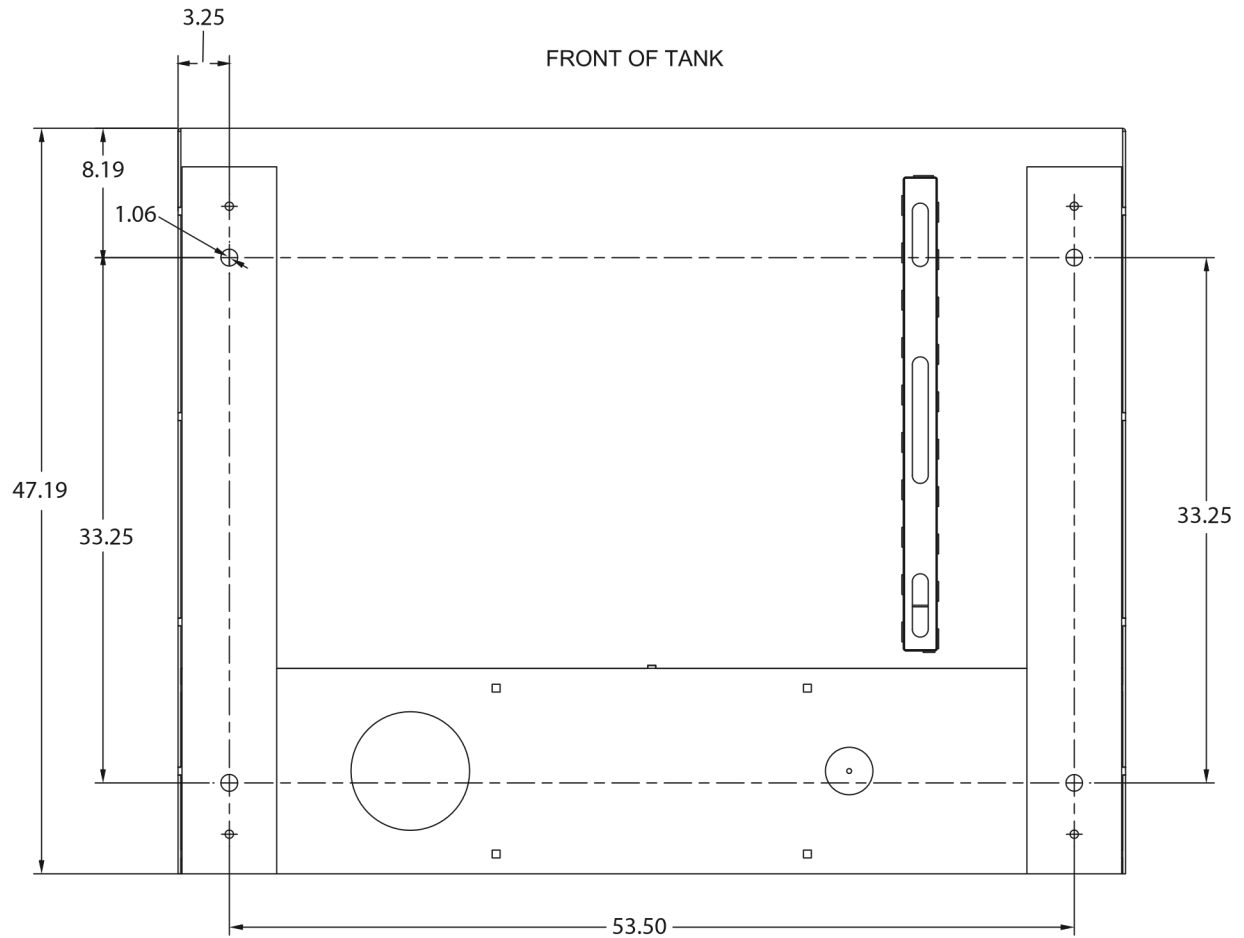

**Work Envelope Dimensions**

**Side View**

## HONE WORK ENVELOPE DIMENSIONS

Side View

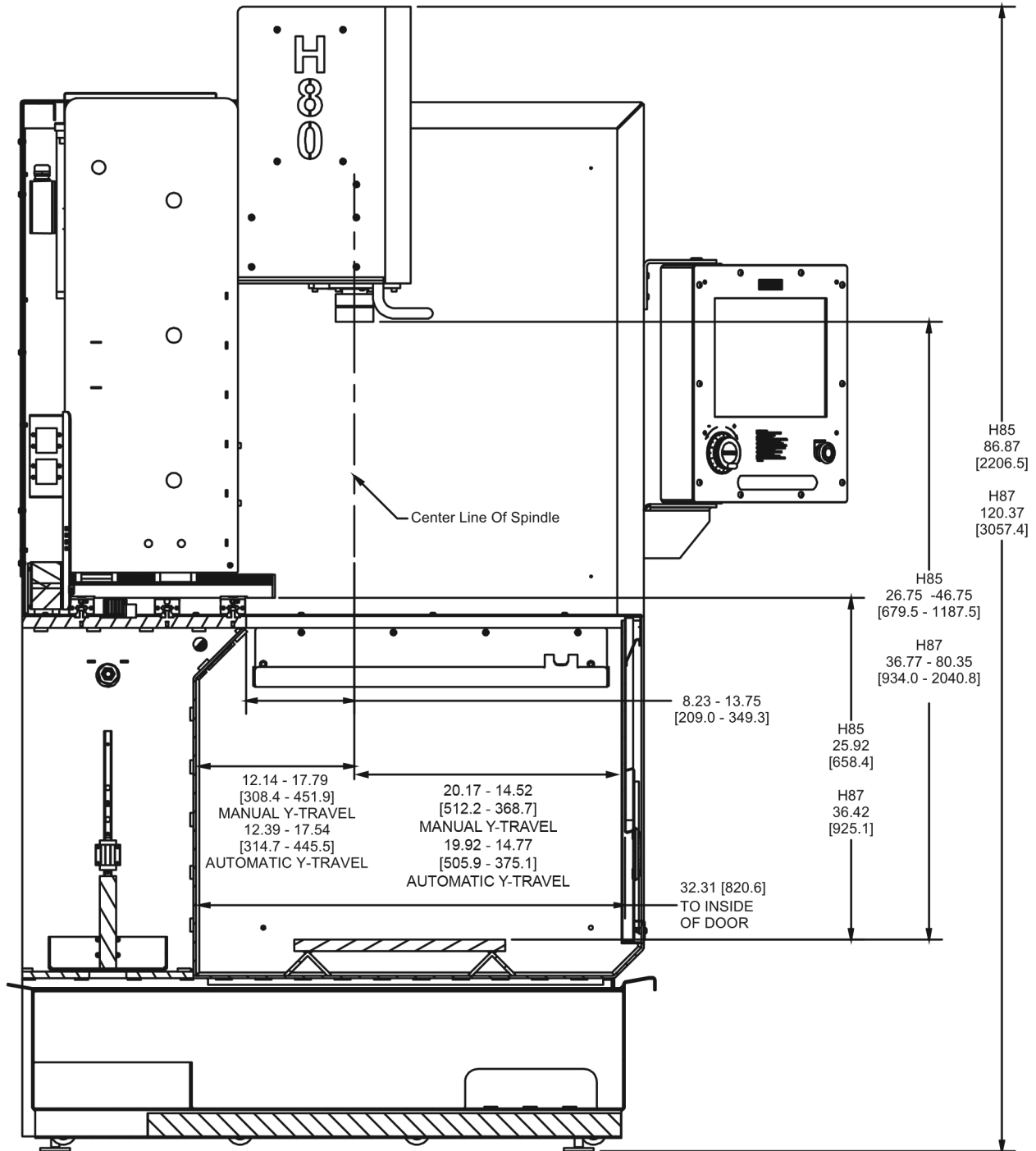

Top View

HONE WORK ENVELOPE DIMENSIONS  
TOP VIEW

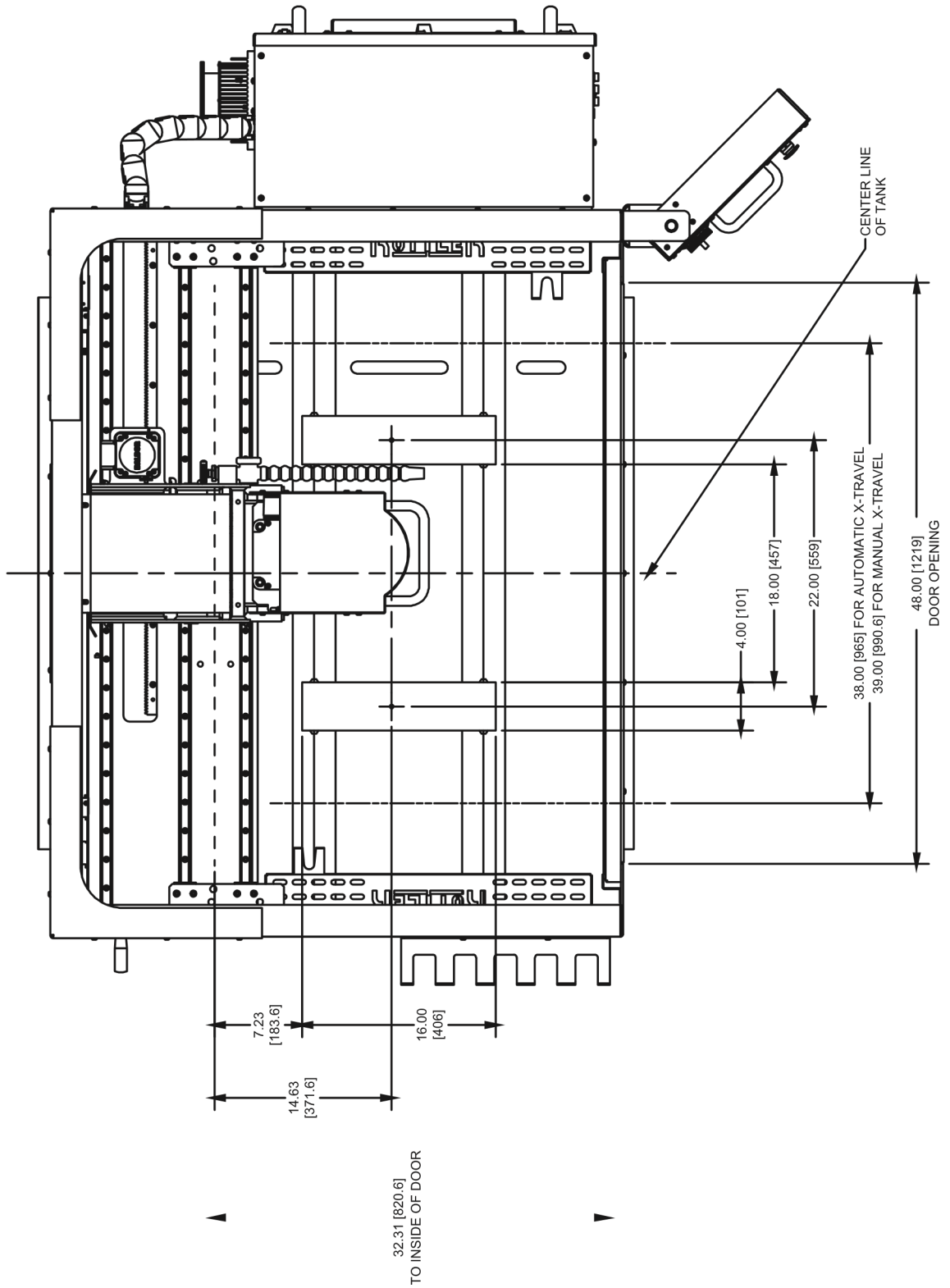

## Installation Procedure

### Location

The productivity of this machine will depend to a great extent on its proper initial installation, particularly the means by which cylinder blocks are lifted into the machine as well as the material handling to and from other operations in your shop.

The proper loading arrangement and location for your H85AX machine is extremely important.

A slow travel (6' to 10' per min.) power hoist, operated from either a bridge crane or a jib crane arrangement works very well. A 1000-lb. hoist is generally adequate for lifting the engine block. An air hoist with speed control makes an ideal method for fast, convenient loading.

If some production honing with this machine is anticipated, and the cylinder blocks are not directly loaded and unloaded from a conveyor, we would recommend considerable attention be given to the crane so that it covers an adequate area to allow the operator to back up and remove cylinder blocks without cluttering up his own area. If two machines are to be operated by one operator, we recommend that the open faces be placed at right angles to each other, with the machines approximately three feet apart.

### Unpacking

Carefully uncrate the H85AX Machine. Remove all equipment in splash tank.

Completely clean the machine exposed metal surfaces with solvent. Rust inhibitor is applied to the machine at the time of shipment and must be removed before operating the machine.

### Leveling

Four cap screws and jam nuts are provided with the machine for leveling. Insert the screws from the bottom of the base. Place the jam nuts on top of the threaded hole in the base.

Using a precision level, level the upper table within .002" per foot in both directions (Except favor the high setting to the front for best coolant return).

### Coolant



Refer to the Coolant section in Chapter 5 of this manual for proper coolant types and mixes. Be sure to read the MSDS section of this manual and exercise due caution concerning coolant hazard.

### Power Supply

This machine has the following power requirements:

- 208 to 240 VAC
- Single or Three Phase Power
- 50 or 60 Hz
- 25 Amps

See illustration below for correct connection of incoming power. Measured power at the machine's main breaker must be within the required range listed above. If incoming power is not within range, a

transformer must be used. Failure to do so will cause the machine to function abnormally and cause permanent damage to the electronic control system.

Some electrical services contain a “Hot Leg, High Leg, or Wild Leg”, where one leg measures 208VAC to Ground instead of 120VAC. Use of the “Hot Leg, High Leg, or Wild Leg” is NOT permitted on this machine. If a “Hot Leg, High Leg, or Wild Leg” is present, connect the machine in the Single Phase configuration shown below.

**IMPORTANT** *Electrically connect in accordance with national and local electrical codes.*

**CAUTION** *Do not attempt to connect more 240VAC to this machine.*

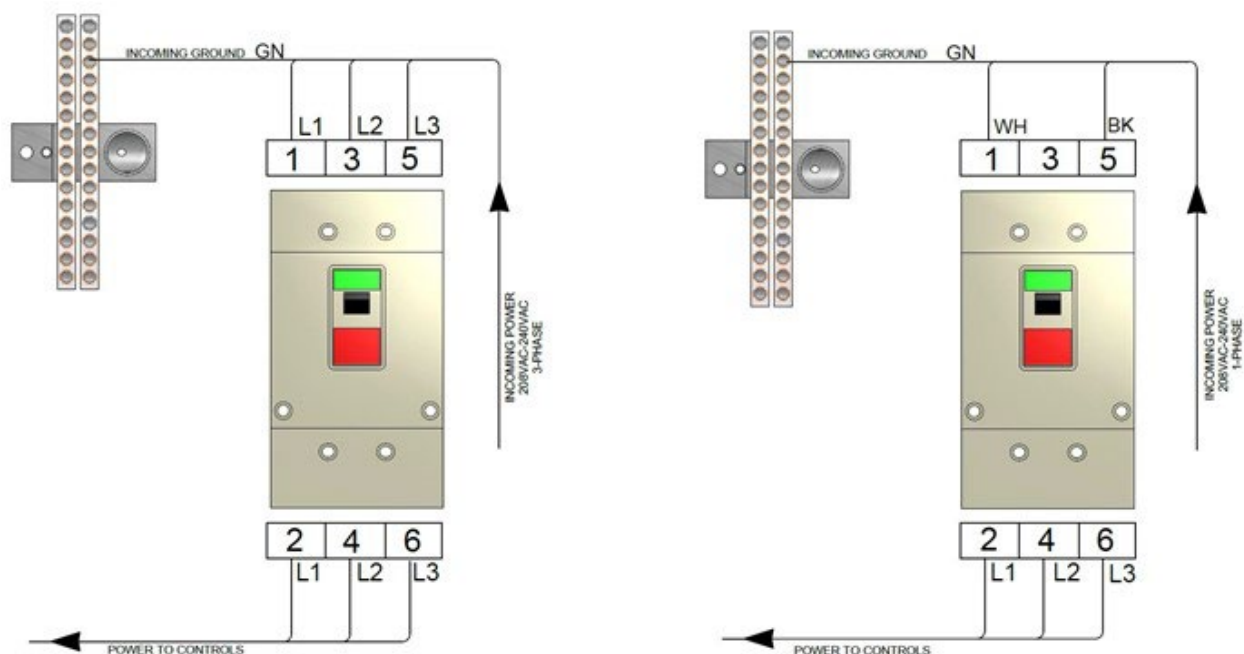

## Grounding

The machine requires a good earth ground. The grounding conductor from the incoming power source must be connected to the grounding block located inside of the electrical cabinet. A ground rod installed in addition to the electrical service grounding conductor is permitted, but must be connected directly to the grounding block inside of the electrical cabinet. Connecting the ground rod to the machine base is not permitted. Consult a Licensed Electrician in your area to assess the installation, and install the appropriate ground rod if necessary. Failure to do so may lead to an installation that is unsafe and does not meet national and local electric codes.

## Transformer Connections

This machine has the following minimum transformer size requirement:

- 15 kVA



If a transformer is necessary for machine installation, please refer to the diagram below for connection information. Transformers must be sized to meet the minimum power requirements listed above. Consult a Licensed Electrician in your area for transformer selection and installation.

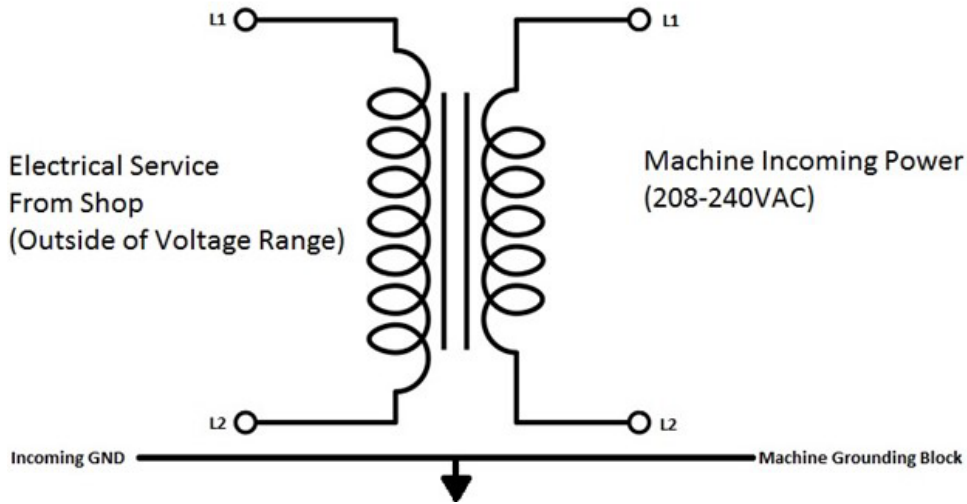
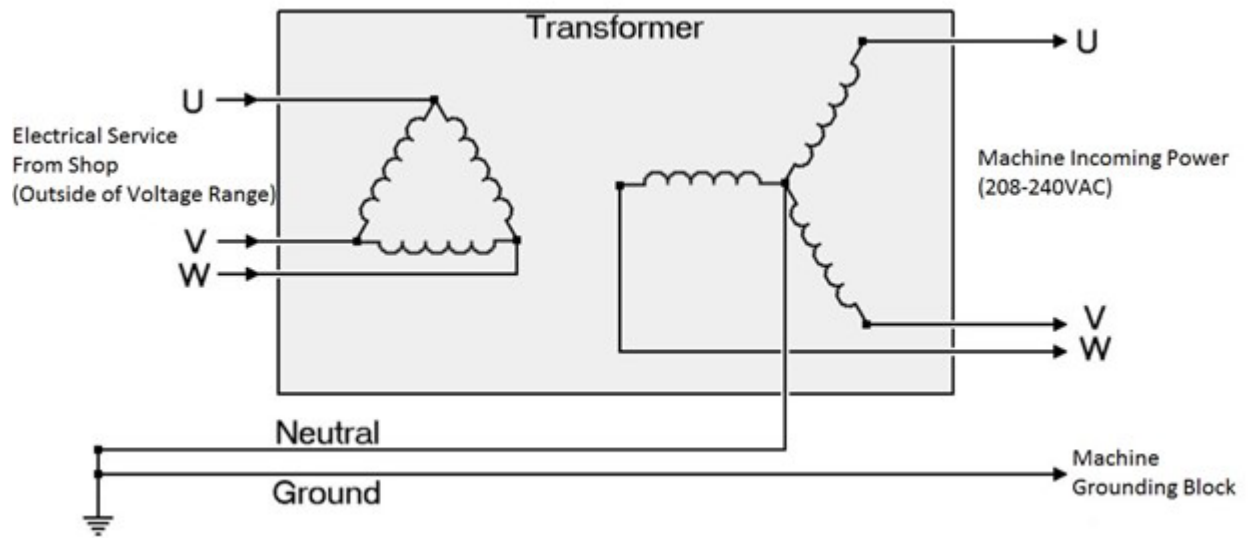

## Creating a Skype Account

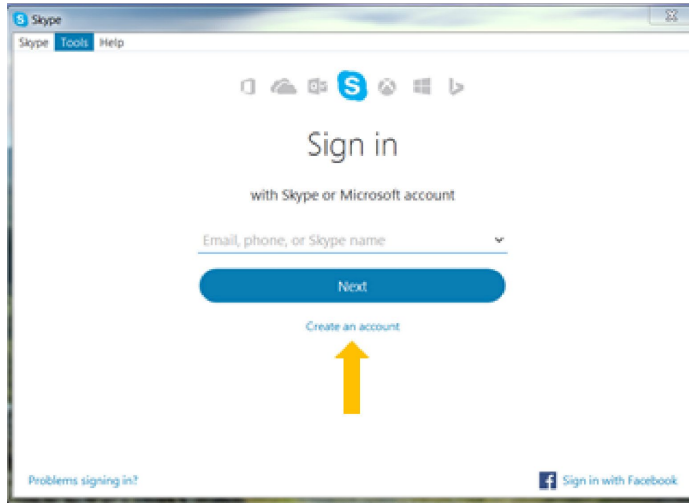

Click on create an account

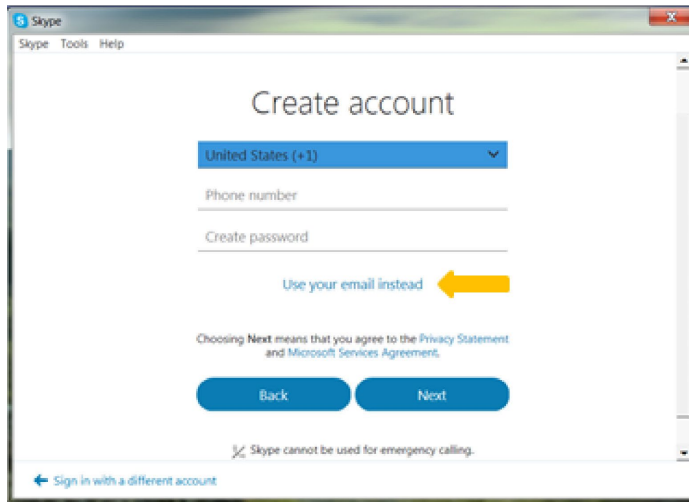

Click on: Use your email instead

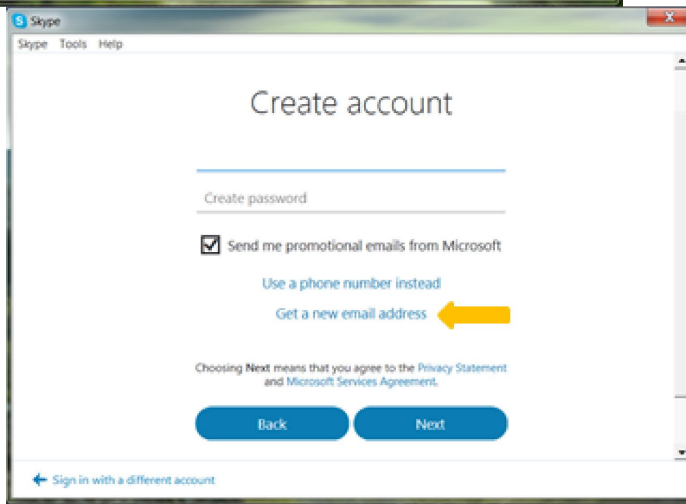
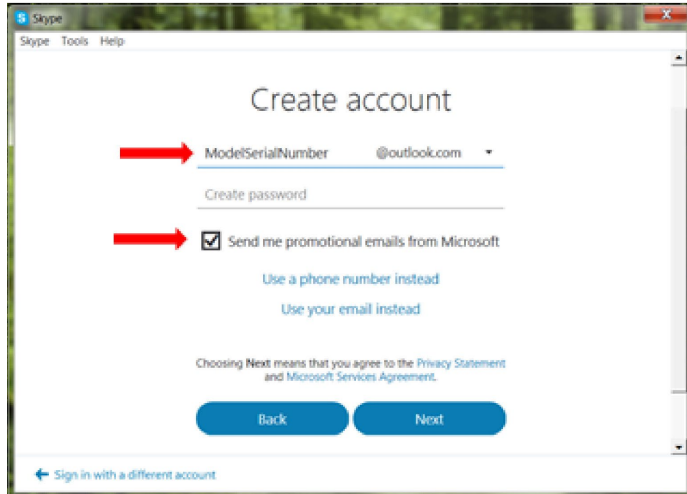

Click on: Get new email

address Name the email account using the Rottler machine Model and Serial number. Ex:

H85A111, EM69P001

Create a password that is easy to remember.

**Uncheck** the box to receive emails from Microsoft.

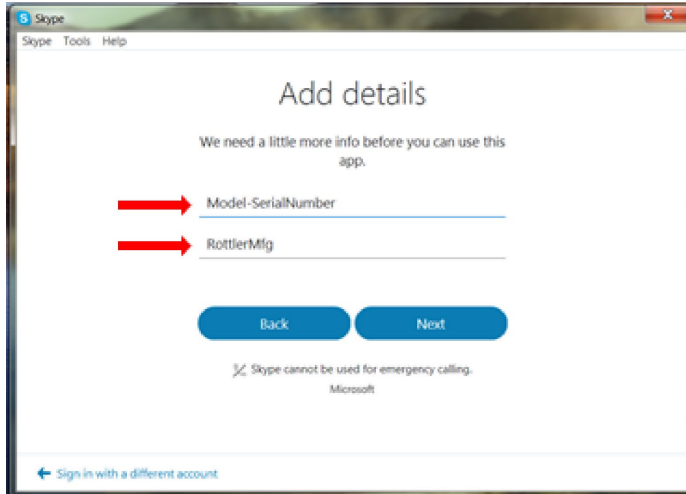

First Name: Model-Serial Number

Ex: H85A-111, EM69P-001

Last Name: RottlerMfg

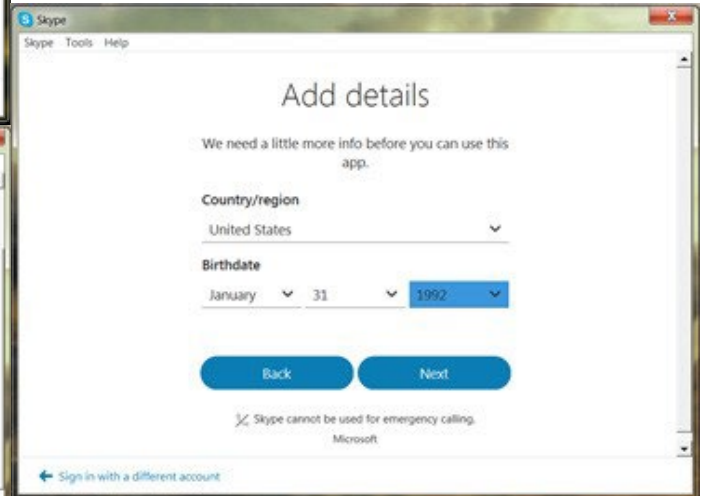
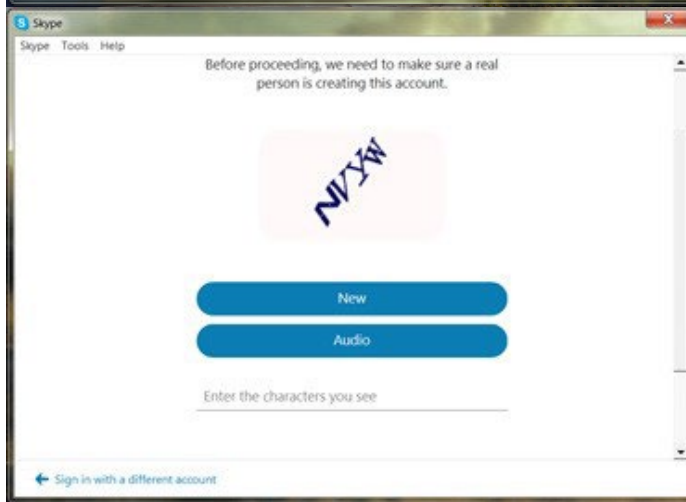

Select your Country/region

Birthday: Today's date, year 1992

Type the code exactly as it appears.

Click "Next"

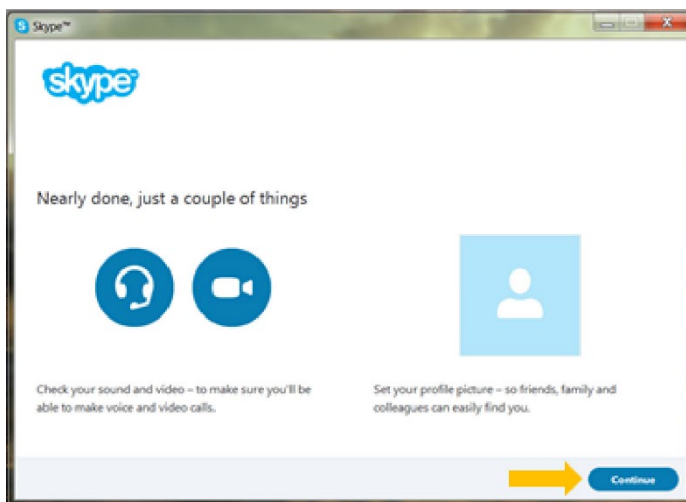

Click "Continue"

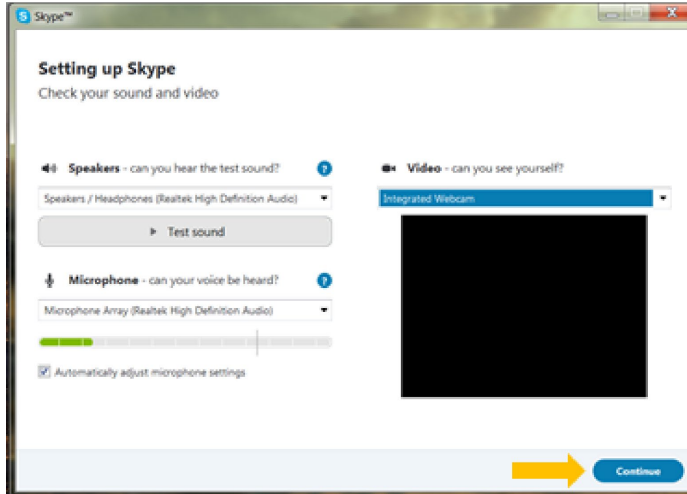

If your headset and/or web camera are hooked up you can verify that they are working here.

Otherwise, click "Continue"

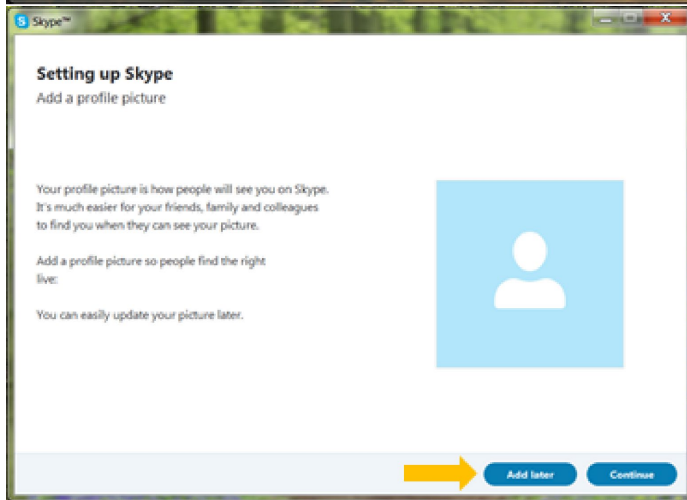

Click "Add later" to skip this part.

Your Skype account is set up and ready for use.