

ROTTLER

SG100XY CNC CYLINDER HEAD SEAT & GUIDE MACHINE MACHINE MAINTENANCE AND PARTS MANUAL

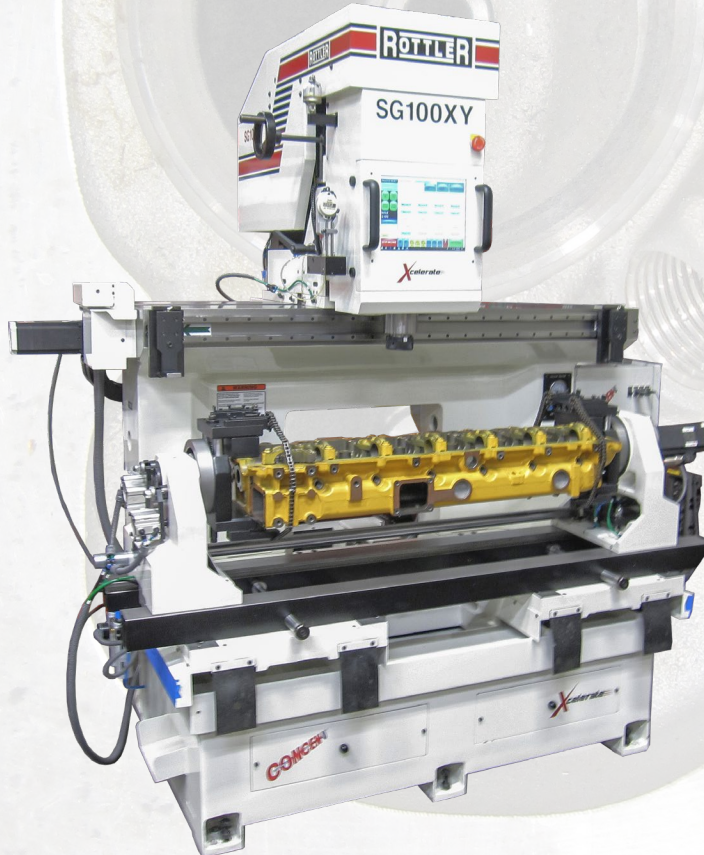

PARTS ORDERING

For optional equipment catalogs, please visit <https://www.rottlermfg.com/documentation.php>

For fastest service ordering parts or equipment, contact us via e-mail with the information below. For customers within the U.S., send emails to parts@rottlermfg.com, for customers outside of the U.S., use intlparts@rottlermfg.com

Have the following information on hand to expedite the ordering process:

1. Your name, business name, and contact number
2. Customer number, or your billing address if you do not have a customer number
3. Shipping address if different from the billing address
4. Machine model and serial number
5. Part number and description of the item(s) to order
6. Preferred method of shipment

For customers outside of the U.S. requiring faster service, contact your local distributor.

In some cases, you may be requested to send a photo of the part you are ordering if it is a replacement part or does not appear in our database.

If you are unsure which part you need to order, contact our service department, and ask to speak to one of our service consultants. They will assist you in determining which part(s) you require.

THERE IS A MINIMUM ORDER OF \$25.00

MANUAL SECTIONS

INTRODUCTION

MAINTENANCE

TROUBLESHOOTING

MACHINE PARTS

SDS

INTRODUCTION

Contents

Introduction	1-2
Description	1-3
Disclaimer	1-3
Limited Warranty	1-4
Online Documentation Access	1-5

Introduction

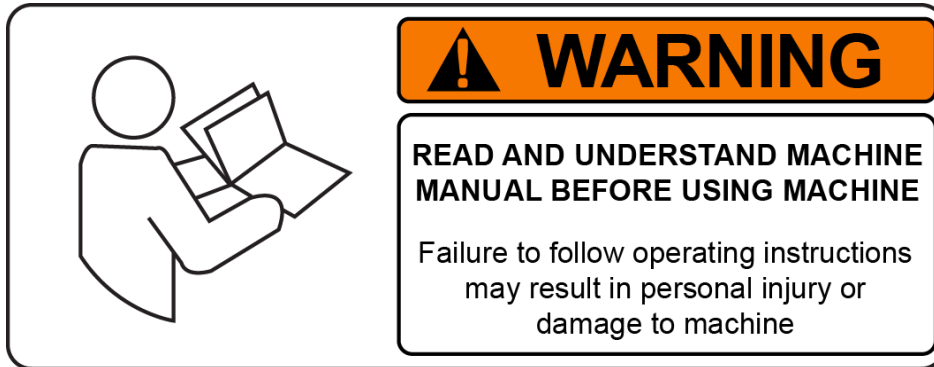

READ THE SAFETY CHAPTER BEFORE INSTALLING MACHINE. THOROUGHLY UNDERSTAND ALL SAFETY ISSUES BEFORE OPERATING MACHINE.

ATTENTION OWNER/BUSINESS MANAGER

To validate the warranty on your new Rottler machine, please be sure to sign and complete the “Installation Report” located in the Installation Chapter of this manual.

We suggest that the new user of the SG100XY read the CONTROL DEFINITIONS to get an idea how the machine operates.

The Operating Instructions chapter should be read in order to familiarize the user with the actual button pushing sequences required to carry out a job. These chapters in the manual should be considered an introduction. As the operators of the SG100XY series machines gain experience with using the different functions of the machine, complicated setups and programs will make more sense.

The rest of the manual contains information and part number reference on fixtures, cutting tools, and machine maintenance. The operator should read and become familiar with these areas as well.

Description

The Rottler SG100XY ACTIV spindle is mounted on a sphere which allows the UNIPILLOT to automatically center with the valve guide centerline while the Workhead is floating on air cushions. Once air floating stops and the Workhead clamps, the UNIPILLOT and valve guide centerline are maintained while cutting the valve seat. ACTIV SPINDLE - Spherical Pneumatic Automatic Alignment System built into the Spindle for fast location of the pilot into the Valve Guide and Accurate Centering (Patent Pending) Air Float Work Head on Intermediate Base Plate Heavy Duty Spindle - Diameter 3.70" (94mm) Hardened and Ground with 10" (250mm) of vertical travel. Rottler Automatic Tightening and Quick Release Spindle Lock Nut System for One Hand Operation for fitting and removing tooling to and from the spindle – never comes loose! Gives Best Concentricity Rottler's Rigid Precision carbide centering UNIPILLOTS are manufactured to less than one tenth (.002mm) tolerance. Combined with the light weight air float Workhead the SG100XY gives perfect centering in the valve guide and the best concentricity of any machine on the market.

Disclaimer

The SG100XY Manual (henceforth to be referred to as the "Manual") is proprietary to Rottler Manufacturing LLC. ("Rottler Manufacturing") and no ownership rights are hereby transferred. No part of the Manual shall be used, reproduced, translated, converted, adapted, stored in a retrieval system, communicated or transmitted by any means, for any commercial purpose, including without limitation, sale, resale, license, rental or lease, without the prior express written consent of Rottler Manufacturing.

Rottler Manufacturing does not make any representations, warranties or guarantees, express or implied, as to the accuracy or completeness of the Manual. Users must be aware that updates and amendments will be made from time to time to the Manual. It is the user's responsibility to determine whether there have been any such updates or amendments. Neither Rottler Manufacturing nor any of its directors, officers, employees or agents shall not be liable in any manner whatsoever to any person for any loss, damage, injury, liability, cost or expense of any nature, including without limitation incidental, special, direct or consequential damages arising out of or in connection with the use of the Manual.

Rottler Manufacturing and its employees or representatives are not responsible for any information regarding final specifications of any workpiece that is created as a final product when using Rottler equipment. It is the responsibility of the end user of Rottler equipment to determine the final dimensions and finishes of the workpiece that they are working on. Any information regarding final dimensions and finishes that appears in any Rottler literature or that is expressed by anyone representing Rottler is to be regarded as general information to help with the demonstration of or for operator training of Rottler equipment.

Limited Warranty

Rottler Manufacturing Company Model SG100XY parts and equipment is warranted as to materials and workmanship. This limited warranty remains in effect for one year from the date of installation or two years from the date of the original shipment from Rottler or whichever date occurs first. This only applies if the machine is owned and operated by the original purchaser and is operated and maintained as per the instructions in the manual. A machine is warranted only if the Installation Report has been properly executed by a certified installation person and received by Rottler at the time of actual installation.

The products are warranted upon delivery to conform to their published specifications and to be free from defects in material and workmanship under normal use for a period of one year from shipment. Should a product not be as warranted, Rottler sole obligation shall be, at its option, to repair, correct or replace the product or to refund the amounts paid for the Product upon its return to a location designated by Rottler. No warranty shall extend to rapid wear Products (including tooling) or to Products which have been subject to misuse (including any use contrary to Rottler instructions), neglect, accident (including during shipment), improper handling or installation, or subject to any modification, repair or service not certified by Rottler. Rottler shall not be liable for any consequential, direct or indirect damages or for any other injury or loss. Buyer waives any right, beyond the foregoing warranty, to make a claim against Rottler. No warranty is provided for any Products not paid in full.

Merchandise cannot be returned to Rottler without prior approval. Customer must contact the Parts Department to get approval and to be issued a Return Goods Authorization number (**RGR#**). Merchandise authorized for return must be returned prepaid. If merchandise is returned with shipping charges collect, the actual amount of these charges may be deducted from any credit which may be due the customer. The **RGR #** assigned by the Parts Department should be written on the shipping label and must appear on a copy of the invoice(s) covering the original shipment. This invoice copy must be included in the box with the parts. Shipment must contain **ONLY** those items on the **RGR** as approved for return. Merchandise must be received within 10 days of the date of **RGR** or the **RGR** will be canceled. All returned merchandise may be subject to a 20% restocking fee on under \$1,000.00 amount or 10% on any items over \$1,000.00. Parts or tooling over 30 days old are considered as customer property and can only be returned with prior approval from Rottler Corporation Management.

The issuance of a **RGR DOES NOT** guarantee credit - it is only authorization for the return of the goods. Credit for return merchandise is at the sole discretion of Rottler. Credit will be issued only after inspection of returned goods.

Tools proven to be defective within the warranty period will be repaired or replaced at the factory's option. We accept no responsibility for defects caused by external damage, wear, abuse, or misuse, nor do we accept any obligation to provide compensation for direct or indirect costs in connection with cases covered by the warranty.

Online Documentation Access

Online documentation for machines and optional equipment can be accessed at the Rottler website. To access documentation open your browser and navigate to <https://www.rottlermfg.com>.

Scroll to the bottom of the page and under the Owner Resources title click the type of documentation you want to access.

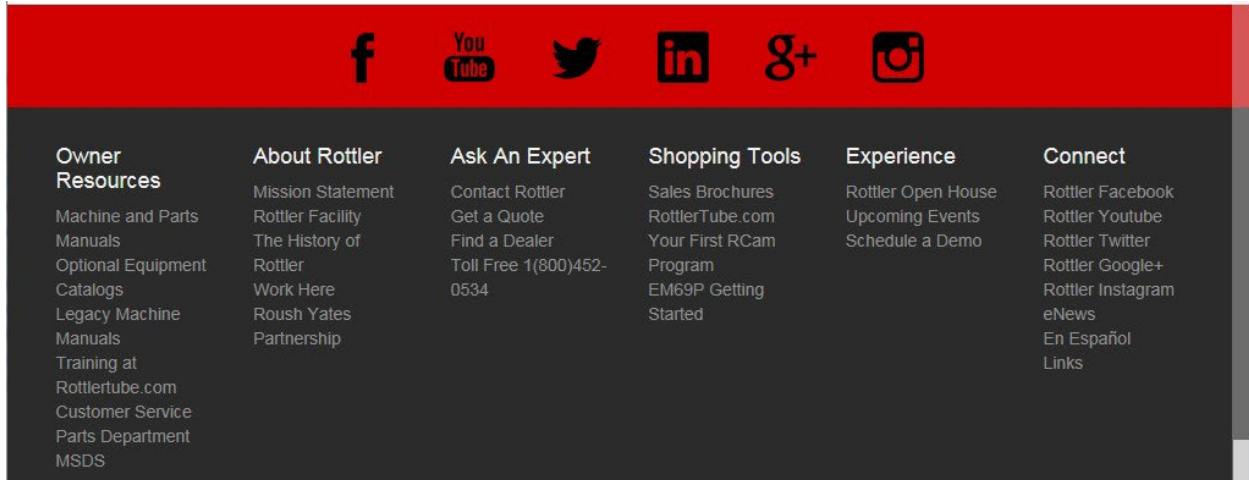

If a log in window pops up asking for user name and password fill in the blanks as shown.

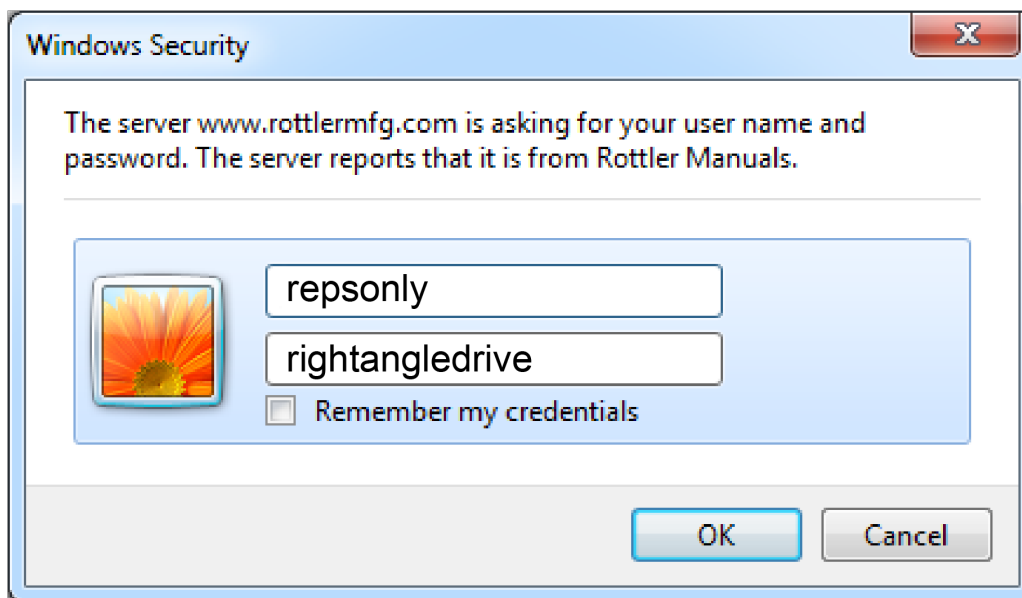

MAINTENANCE

Contents

Maintenance	2-1
Quick Reference Lubrication Chart	2-1
Preventative Maintenance Quick Reference Chart	2-1
Air Adjustments	2-2
Float	2-2
Float surfaces	2-2
Calibrating the Digital Level	2-3
Spindle	2-3
Rebuilding the UPT5200 Unipilot Holder	2-4
Adjusting And Aligning The Outer Spindle On SG Models	2-6
Adjusting Outer Spindle Clearance	2-7
Spindle Lock Nut Service Procedure	2-8
Replacing the Motherboard Battery	2-9
Setting the Play of Z-Axis Ball Screw	2-12

Maintenance

Quick Reference Lubrication Chart

Refer to the maintenance section in the manual for lubrication location points and instruction.

Assembly	Frequency	Lube Operation	Recommended Lubricant	Date Serviced
Outer Spindle	8 Hours	Clean and Wipe with oil	ISO VG 68 Way Oil	
Brass guide shoes/slide	500 Hours	Clean and wipe with oil	ISO VG 68 Way Oil	
Grease spindle Rack and pinion	500 Hours	Clean and grease	NLGI #2 White Lithium Grease	
Grease spindle worm wheel and worm shaft	500 Hours	Clean and grease	NLGI #2 White Lithium Grease	
Grease spindle drive shaft	500 Hours	Clean and grease	NLGI #2 White Lithium Grease	
Grease rollover clamp fixture bearings	200 Hours	Clean and grease	NLGI #2 White Lithium Grease	
Grease clamp fixture Pins and Acme screw	200 Hours	Clean and grease	NLGI #2 White Lithium Grease	

Preventative Maintenance Quick Reference Chart

Refer to the procedures in the maintenance section of the manual to make or check these adjustments. Not all of the items listed in the table below have adjustment. The information should be recorded and the amount of wear tracked so the part can be replaced before down time on the machine occurs.

Procedure	Frequency	Date Serviced/Comments
Clean top and bottom float tables	8 Hours	
Outer Spindle Bushing Adjustment	500 Hours	
Brass Shoe Adjustment	500 Hours	
Angle sensor calibration	500 Hours	
Spindle Drive Belt Adjustment	1000 Hours	
Adjust workhead clamp plate bearings	1000 Hours	
Rack and pinion adjustment.	1000 Hours	
Machine Level Adjustment	1000 Hours	

CAUTION All floating surfaces should be dry and clean do not oil the surfaces, oil will cause the work heat not to float properly.

Air Adjustments



Float

The float regulators are located on the left side of machine base. Marked “Work Head Air Float Adjustment” If the work head is not floating properly it could be from too much or too little air from the regulator. Starting with all regulators set at 1 bar with “workhead float” button activated, slowly turn all up .5 bar at a time until workhead start to float. Pushing work head front to rear checking for stiff spots. If workhead is dragging in the forward position, (workhead pulled closest to operator) raise the 2 front regulators 1 mark until it floats without dragging. Same for rear. You may have to go back and forth a few times to get this correct. If workhead is not dragging lower the PSI until it does and then raise 1 notch at a time until it is free. Typically the front two regulators will be slightly higher than the rear two. Once the correct float is established lock the regulators in place by pushing in on the blue adjusting knob

CAUTION Use as little air as possible to achieve correct floatation. Using too much air will could cause the spindle base to vibrate and not center properly on the on the pilot.

Float surfaces

CAUTION Wipe clean daily

All floating surfaces should be dry and clean do not oil the surfaces, oil will cause the work heat not to float properly.

Calibrating the Digital Level

NOTE: Even though the level has been carefully calibrated at the factory, it is a good idea to recheck calibration before putting the machine into service. In the event that the level is dropped or handled roughly then the following recalibration methods should be implemented.

The level assembly is referenced to the spindle via the level pin. It is there for important to check alignment of pin in reference to the spindle. This is accomplished by mounting a magnetic base dial indicator to the machine spindle and sweeping the pin vertically by raising or lowering spindle to check alignment. Pin alignment should be checked in two positions at 90 degrees to each other. If the pin alignment needs correcting, do so with the set screws located at base of pin block.

Install level on pin. Orient level to read left to right. Tilt head left or right until level reads 0.00. Now rotate level 180 degrees. The reading should be 0.00, if not then it will be necessary to calibrate the inclinometer to the level body. This is accomplished by loosening the inclinometers two retaining screws and pivoting the inclinometer until it repeats when level is rotated 180 degrees.

Example: level reads 0.05 to the left, when rotated 180 degrees to the right it should read minus 0.05.

Check the level reading with the pickup oriented front to back. It should read 0.00 if the machine has been properly leveled with a machinist level.

If the LED does not read 0.00 then chances are the machine's leveling procedures have not been properly followed or there are internal problems with the levels electronics.

The sensitivity of the level is so great that it may not zero totally, even while the machine is not being touched. The alignment tolerance for installing guides is plus or minus .05 degrees, and for forming three angle seats is plus or minus .05 degrees.

Spindle

Wipe clean and oil 5 drops daily. To oil, lift lever at top of oiler. To adjust, rotate lever knob.

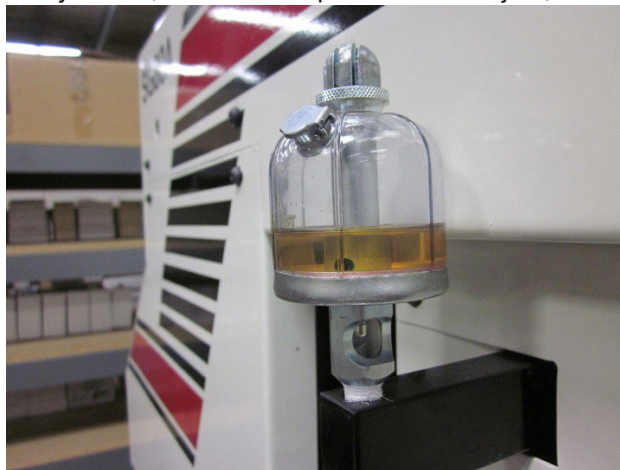

Rebuilding the UPT5200 Unipilot Holder



Align the pin and push through until To remove the cap unscrew the cap, this cap has left-hand you
able get the sleeve up and threads; remove the long spring with the spacing Rod and the
remove the components to replace. Trust Pad (See pictures below)



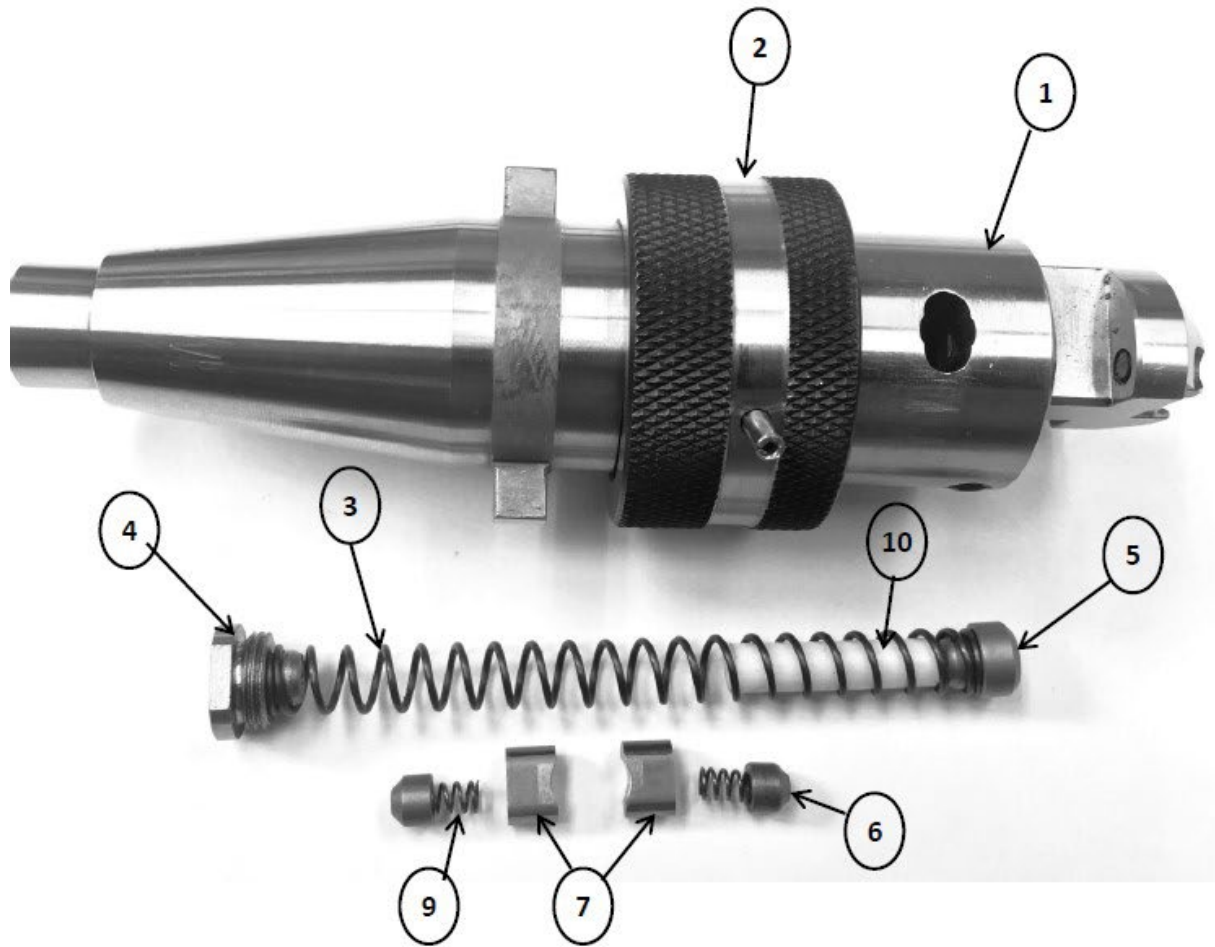

UPT5200 Rebuilding Kit Parts Details

Sr. No.	Part No.	Description	Qty.
1	5201	Toolholder Body Only (UPT5200)	1
2	5207	Toolholder Adapter Collar	1
3	555-19-10	5203-1 – Spring Long	1
4	555-19-9	5202 - Holding Screw	1
5	555-19-12	5104 - Trust Pad.	1
6	555-19-2	5205-1 - Plunger Pin Outer	2
7	555-19-3	5205-2 - Plunger Pin Inner	2
8	UCPXXX	UNIPILOT.375" (9.52mm) Shank	1
9	555-19-4	5203-3 - Compression Spring	2
10	555-19-11	5209 - Spacing Rod	1

Adjusting And Aligning The Outer Spindle On SG Models

There are 2 brass guide shoes located on the guide plate on top of the spindle that align the rack gear on the back of the spindle with the pinion gear that moves the spindle up and down.

Lower the spindle to the center position of travel.



Check the guide plate at the top of the spindle, tighten if necessary. ¶

Clean and lightly lubricate sliding guide surfaces with grease. Adjust brass guide shoes on guide plate so that there is no twisting movement. Run the spindle through its full travel to confirm that there is no binding.

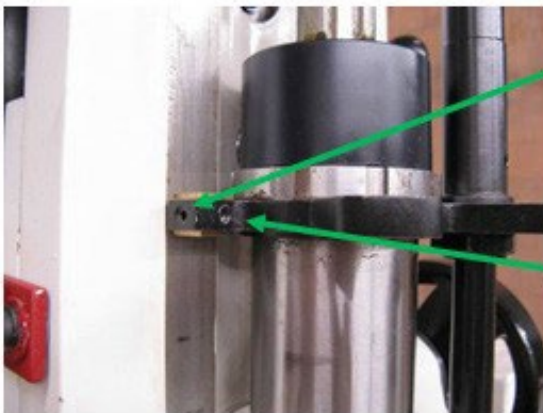

Loosen locking screw to adjust brass guide shoe. Tighten after adjusting. ¶

Use adjusting screw to adjust brass guide shoe.

Adjusting Outer Spindle Clearance



Loosen the 4 lock bolts.



Loosen the 4 adjusting set screws.

Clean outer spindle and lubricate – add a few drops of oil to a clean cloth and wipe outer spindle.

Starting with the bottom set of lock bolt and adjusting set screws, tighten the lock bolt until there is drag on the spindle when it is move through its range of travel.

Then tighten the adjusting set screw until the amount of drag on the spindle is reduced to the point that there is a slight drag on the spindle through its range of travel.

You may have to make further adjustment to the lock bolt and set screw the get the spindle adjusted properly.

Repeat the above procedure the other 3 sets of lock bolts and set screws.

Spindle Lock Nut Service Procedure

SEAT & GUIDE MACHINE MODELS : SG-8MTS, SG-9MTS, SG-10X & SG-80MTS
SPINDLE LOCK NUT ASSEMBLY & DISMANTLING INSTRUCTIONS.

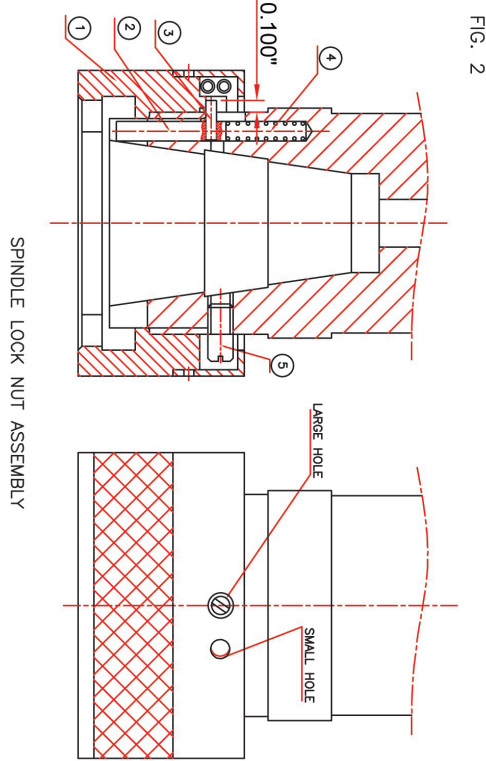
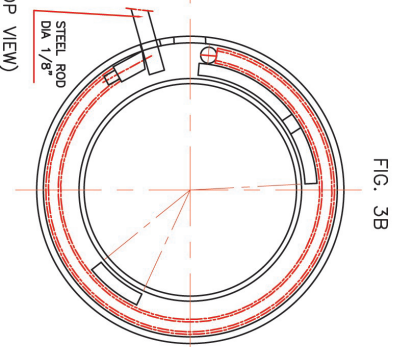
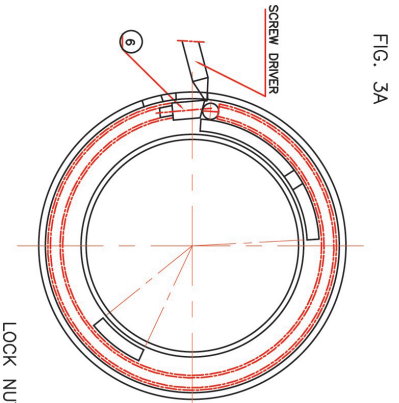
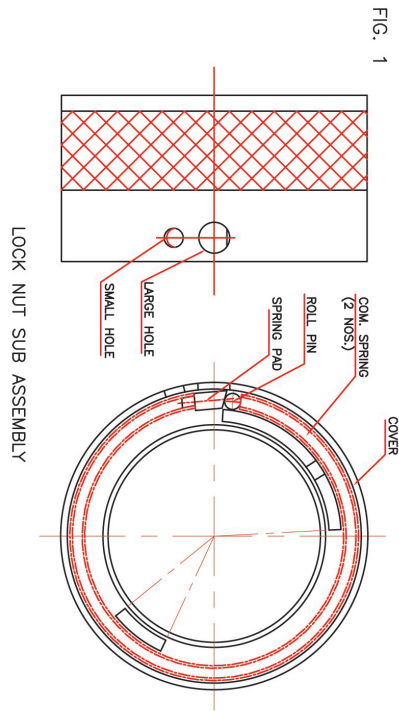

ASSEMBLY OF LOCK NUT (REF. FIG. 2)

1. INSERT SPRING '4' IN THE SPINDLE HOLE FOLLOWED BY PLUNGER PIN '2', KEEPING HOLE ON THE TOP SIDE.
2. ASSEMBLE STOP PIN '3' BY PRESSING UP PLUNGER PIN '2' TILL THE PIN HOLE IN PLUNGER PIN '1' COMES OPPOSITE TO HOLE IN THE SPINDLE. THE PIN SHOULD PROJECT BY 0.100" (2.5MM) FROM SPINDLE SURFACE.
3. START TIGHTENING LOCK NUT '1' ON THE SPINDLE. WHEN IT STOPS, PRESS THE PLUNGER PIN '2' AND CONTINUE TIGHTENING TILL THE LOCK NUT TOUCHES THE SPINDLE.
4. UNSCREW LOCK NUT '1' SLIGHTLY TILL LARGE HOLE IN THE LOCK NUT COMES OPPOSITE THE TAPPED HOLE IN THE SPINDLE.
5. WITH A SMALL SCREW DRIVER PRESS SPRING PAD '6' THROUGH LARGE HOLE SO THAT IT CLEARS THE SMALL HOLE. INSERT A STEEL ROD IN THE SMALL HOLE TO HOLD THE SPRING PAD '6' IN THAT POSITION. TAKE OUT SCREW DRIVER, REF. FIG. 3A & 3B.
6. TIGHTEN STOP SCREW '5' IN THE SPINDLE THROUGH LARGE HOLE.
7. RELEASE SPRING PAD '6' BY PULLING OUT THE STEEL ROD. THE LOCK NUT ASSEMBLY IS NOW COMPLETED. CHECK ITS FUNCTIONING MANUALLY BEFORE MACHINING.

DISMANTLING OF LOCK NUT (REF. FIG. 2)

1. ROTATE THE SPINDLE TO SEE IF LARGE HOLE IS OPPOSITE TO STOP SCREW '5'. IN CASE IT IS NOT SO, PRESS THE PLUNGER PIN '2' UPWARDS. THIS WILL BRING THE LARGE HOLE OPPOSITE TO STOP SCREW '5'.
2. TAKEOUT STOP SCREW '5' BY UNSCREWING THE SAME.
3. PRESS PLUNGER PIN '2' & START UNSCREWING THE LOCK NUT '1' TILL IT COMES OUT.
4. PUSH STOP PIN '3' TO COME OUT OF PLUNGER PIN '2'.
5. TAKE OUT PLUNGER PIN '2' AND SPRING '4'.
6. DO NOT TEMPER WITH LOCK NUT SUB-ASSEMBLY. ASK FOR A NEW PIECE IF DAMAGED. SPINDLE LOCK NUT IS ALWAYS SUPPLIED IN SUB-ASSEMBLED CONDUCTION WITH TWO COIL SPRINGS, SPRING PAD, ROLL PIN & COVER AS SHOWN IN FIG. 1

Replacing the Motherboard Battery

If computer fails to boot up and you get a CMOS error message on the screen, then the battery on the computer motherboard has failed and needs to be replaced.

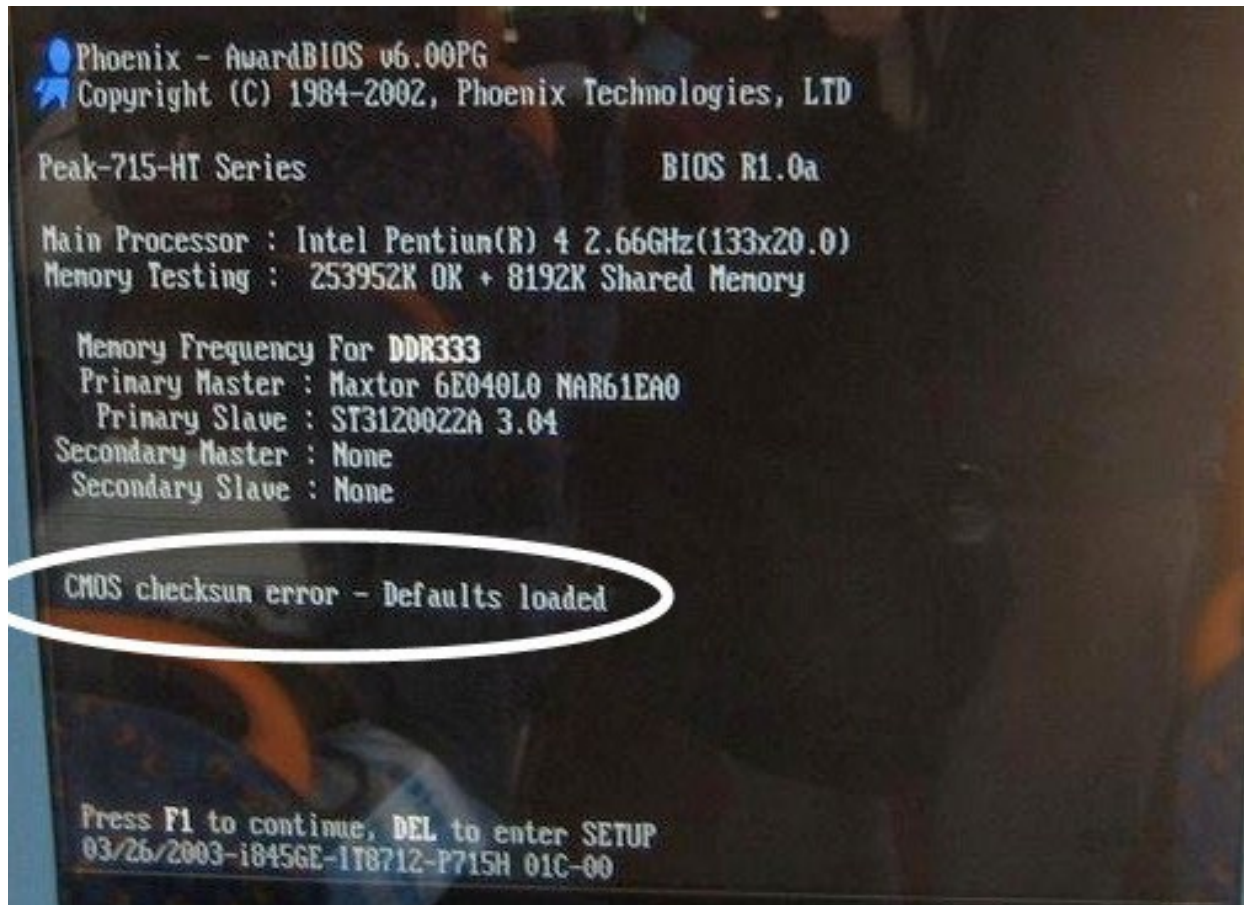

The following is the procedure for replacing the motherboard battery.

Turn off the power on the electrical enclosure and remove the enclosure cover.



Locate the computer and check to see that the power light is not on. If it is on turn off the power switch.

Note: On some machines it may be necessary to unbolt the computer from the enclosure in order to gain access to the cover screws.

Remove the 6 screws indicated by the arrows from the cover.

Remove the cover.



Locate the battery on the motherboard.



Push the battery retention clip away from the battery. When the clip is released the battery will pop up.

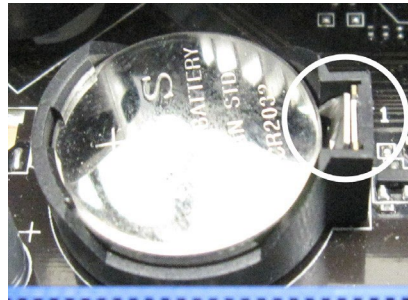

Remove the battery and place new battery in the battery holder.

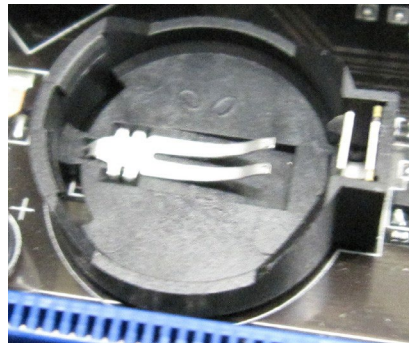

Using your finger tip push down on the battery until the retention clip is in its lock position.



Replace computer cover and make sure that power switch on the computer is on.
Replace the enclosure cover and switch power back on.

Setting the Play of Z-Axis Ball Screw

INSTRUCTIONS FOR SETTING THE PLAY OF BALL SCREW (Z-AXIS) - SG100XY

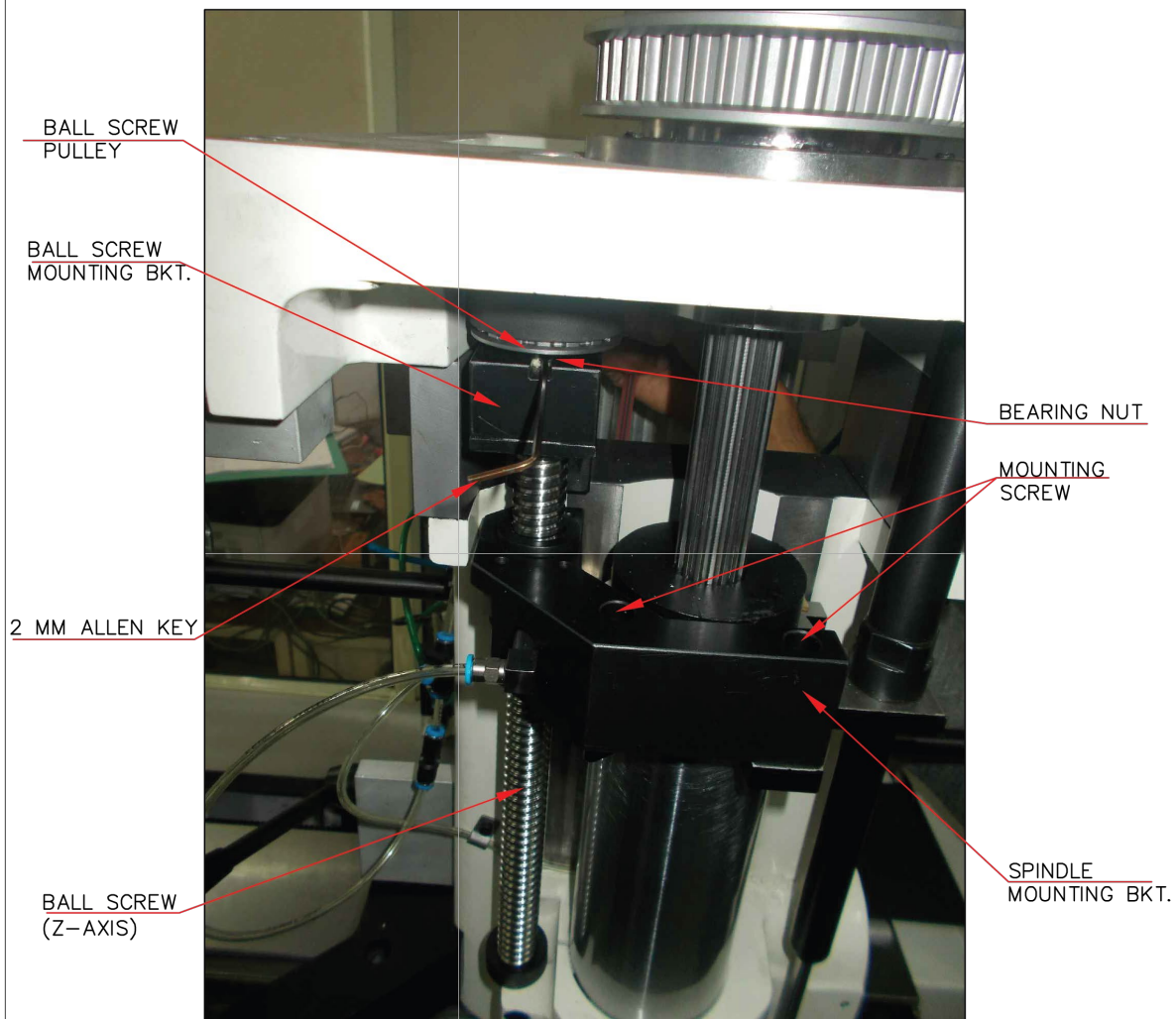

INSTRUCTIONS FOR SETTING THE PLAY OF BALL SCREW (Z-AXIS)

1. SWITCH OFF ALL THE ELECTRICAL SUPPLIES.
2. REMOVE FRONT COVER & TOP COVER ASSEMBLIES FOR CLEAR VIEW OF BALL SCREW ASSY.(Z-AXIS)
3. FOR CHECKING THE PLAY IN BALL SCREW (Z-AXIS) LOOSE 2 MOUNTING SCREW OF SPINDLE MOUNTING BKT. USING 5 MM ALLEN KEY.
4. FOR SETTING THE PLAY ,HOLD BEARING NUT THROUGH LOCKING SCREW USING 2 MM ALLEN KEY (AS SHOWN IN FIG.) FOR STOPPING BEARING NUT SHOWN UNDER THE PULLEY.
5. ROTATE THE PULLEY TO THE RIGHT SIDE FOR REDUCING THE PLAY OF BALL SCREW.
6. CHECK THE PLAY IN BALL SCREW BY SPINDLE MOUNTING BKT. BY PUSHING UP & DOWN.
7. IF THERE IS NO PLAY THAN LOCK BEARING NUT THROUGH LOCKING SCREW .
8. TIGHT BOTH THE MOUNTING SCREW .
9. ASSEMBLE BACK THE FRONT COVER & TOP COVER ASSEMBLIES.

DOC. NO. : 440-001
DATE : 20.01.17
SHEET NO. 5

TROUBLESHOOTING

Contents

Workhead Base Does Not Float	3-2
Eccentricity Problems When Cutting Three Angle Seats	3-3
Icon On Screen Does Not Move To Area Touched.	3-4

For further assistance in troubleshooting:

Please visit the service tab of our web page at Send a Service Request www.rottlermfg.com or contact the Rottler Factory Service at service@rottlermfg.com for assistance and your service request.

You may also call Rottler at 1-800-452-0534 or 1-253-872-7050

Please ensure you have the Machine Model and Serial Number available when contacting Rottler for Service

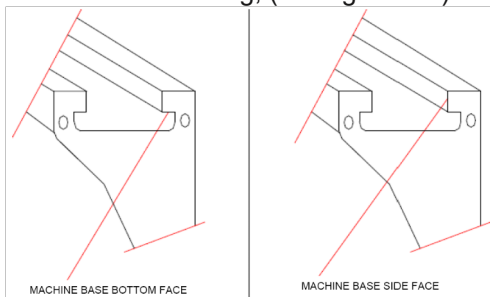
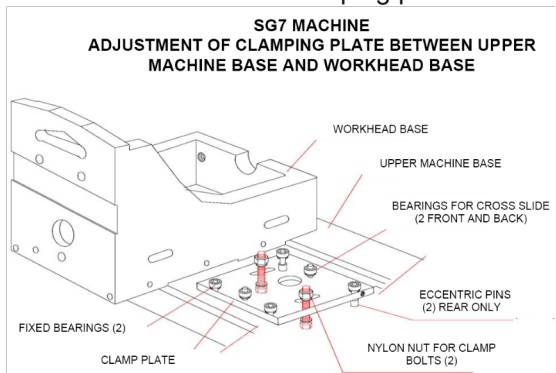
Problem	Possible Cause	Solution
<p>Workhead Base Does Not Float</p>	<p>Insufficient air pressure</p>	<p>Set air pressure of supplied line should be minimum 85 PSI (6 Bars)</p>
	<p>Clamping plate does not drop when unclamped due to less clearance between upper floating base and ball bearings mounted on clamping plate</p>	<p>Take the workhead to one end of the of the upper floating surfaces (Left or Right side) float the workhead and pull it against the front on the T Slatted guide surfaces, then loose the set screws of the eccentric pin to increase clearance by using a feeler gage of 0.008" to 0.010" (0.20mm to 0.25mm) in between the T slotted guide surfaces of the upper base and the eccentric ball bearing; (see fig. below)</p>  <p>Lock the setscrews, remove the feeler gage and inspect if is with the tolerance across the all surfaces.</p> <p>Repeat if it is necessary.</p>
	<p>Clamping plate does not drop when unclamped due to the improper adjustment of the four clamping bolts</p>	<p>Adjust nylock nuts to set he correct clearance between the bottom side face of the locking T-Slot of the floating base (Riser) and the top part of the clamping plate. They are two on the SG7. The dropping clearance when is on the floating mode should be 0.015" (0.38mm)on all the four corners of the workhead clamping plate</p> 

Problem	Possible Cause	Solution
Eccentricity Problems When Cutting Three Angle Seats	Machine is not level	Level machine per instructions in Installation section of this manual
	Workhead is not floating smoothly	Be sure that the work head and main base are clean and floating smoothly side by side and front to back
	Spindle floated to improper center location	Reposition workhead to ensure proper alignment
	Improper setup procedure	<p>The centering switch that is located on the left side of the front panel needs to be on the centering position at the time of centering and machining the valve seat. The Spherical pneumatic switch needs to be on the OFF position and the pilot into the valve guide until reach the proper height or the cutting insert is a few thousands from the valve seat face. Let Workhead flow for few seconds to achieve maximum alignment over the pilot. Be sure there's no contact with the Workhead to allow spindle to stabilize and Cutter to center itself on the valve guide. Release Foot Pedal.</p> <p>Note: Spherical Pneumatic switch should be on the OFF position all the time that you are machining the valve seat; this will give you a positive live centering.</p>
	Toolholder cone dirty	The toolholder cone must be clean before is attached to the spindle and also be sure that the inner spindle cone is clean
	Excessive pressure when cutting seat	Use less pressure when cutting the seat
	Incorrect spindle speed	Adjust spindle speed
	Worn or improperly selected pilot	Check pilot for wear and straightness
	Dull or damaged cutter insert	Replace insert
	Incorrect pilot selection	Follow directions in manual for selecting pilots
	Worn tool holder	Check tool holder with bore gauge to determine if there wear
Worn valve guide	Service valve guides before attempting to cut valve seats	

Problem:
Icon On Screen Does Not Move To Area Touched.

Solution:
Follow the procedure below to recalibrate the touchscreen.

1. Get to the Alignment screen.
 1. If an Elo icon is available in the tool tray at the lower right side of the desktop, click it, then click Align.
 2. Otherwise, go to the Windows Control Panel, double-click Elo Touchscreen and click the Align button on the General tab.
 1. If Windows XP and no Elo icon, click the "Switch to Classic View" button on the left
 2. If Windows 7 and no Elo icon, look for "View by: Category" text toward the upper right; click it and select "Small icons"
2. Touch and release the upper left target; the target should jump to the lower right.
3. Touch and release the lower right target; the target should jump to the upper right.
4. Touch and release the upper right target; a check screen should appear.
5. Touch and release the green check mark; the check screen should disappear.
6. The cursor should now jump to the point of touch.
7. If the Elo Control Panel is open, close it and the Windows Control Panel.

MACHINE PARTS

Contents

REPLACEMENT PARTS	4-1
Consumable Parts	4-1
Carbide Inserts	4-2
Special Profiles	4-2
Carbide Pilots	4-2
SG100XY MACHINE ASSEMBLY PARTS	4-3
Base Table and Riser Assembly	4-3
Base Assembly	4-8
Spindle Assembly	4-11
Transmission Assembly.....	4-15
Head Support Assembly	4-18
Pneumatic System	4-23
Pneumatic Air Hose Diagram	4-25
SG100XY-GE MACHINE ASSEMBLY PARTS	4-27
Bed, Table, and Riser Assembly Parts	4-27
Base Assembly Parts	4-32
Spindle Housing Assembly Parts	4-35
Transmission Assembly Parts.....	4-39
Fixture Assembly Parts	4-42
RBHAR1KIT Repair Kit for RBHAR1	4-45
RBHAR40UPCKIT Repair Kit for RBHAR40UPT	4-46
Pneumatic Circuit Diagram	4-47
Pneumatic Tubing Diagram	4-49

REPLACEMENT PARTS

Consumable Parts

REFERENCE	DESCRIPTION
SLEEVE R1	Spindle adapter replacement sleeve
BSW002	Diamond Wheel Cutting Bit Sharpener replacement Wheel (3.000" Diameter OD by .375" ID)
PRW600PIN	Replaceable Pins for PRW600 Pilot Removable wrench tool
PRW375PIN	Replaceable Pins for PRW375 Pilot Removable wrench tool
PRW20PIN	Replaceable Pins for PRW375 Pilot Removable wrench tool
VT-FP1562	Replacement Foam Pad for Round Vacuum Pad 1.562" diameter
VT-FP1875	Replacement Foam Pad for Round Vacuum Pad 1.875" diameter
VT-FP2125	Replacement Foam Pad for Round Vacuum Pad 2.125" diameter
VT-FP3125	Replacement Foam Pad for Round Vacuum Pad 3.125" diameter
VT-FP25X22	Replacement Foam Pad for Square Vacuum Pad 2.500" x 2.250" square
VT-FP31X20	Replacement Foam Pad for Square Vacuum Pad 3.125" x 2.000" square
VT-FP33X27	Replacement Foam Pad for Square Vacuum Pad 3.375"x 2.750" square
511-29-12F	T7 Torx driver for 1/4" insert (straight angle insert holders only)
511-29-12E	TORX SCREW M2.5 X 0.45 X (straight angle insert holders only)
T8S	T8 Torx Tip Holding Screws
T15S	T15 Torx Tip Holding Screws
MHS-375	Fixed Double Replaceable Insert Milling Head Screws for Large diameter milling Head (3/8" insert)
MHS-250	Fixed Double Replaceable Insert Milling Head Screws for Small diameter milling Head (1/4" insert)
S1032-250	BH375R1 and BH600R1 Tip Holder Looking Screw (10/32" X 1/4") Req. 2
S250-28-250	BH375WR1 Tip Holder Looking Screw 1/4"-28" X 1/4" Req. 2
S1032-437	TH1999 Adjusting Screw (10/32" X 7/16")
S1032-375	TH2000 Adjusting Screw (10/32" X 3/8")
S1032-500	TH2001 Adjusting Screw (10/32" X 1/2")
S1032-625	TH2002 Adjusting Screw (10/32" X 5/8")
S600-1570	TH2003 Adjusting Screw (6.00mm X 15.70mm)
S600-2015	TH2004 Adjusting Screw (6.00mm X 20.15mm)
M10X15X35	SG7 Rollover Fixture Hold down swivel Handle Zinc Handle 35mm (1.375") Long stud (KHF-725)
500-13X2	SG9MTS Rollover Fixture Hold down swivel Handle Zinc Handle 2.000" Long stud (KHF-162)
500-13X1375	SG7- SG9MTS Rollover Fixture Lock swivel Handle Zinc Handle 1.375" Long stud (KHF-158)
ICC003	Insert, Indexable carbide, for Fixed milling heads - large size - for 1.562" and larger cutters
ICC002	Insert, Indexable, carbide, for Fixed milling heads - small size - for 1.250" to 1.500" cutters

Carbide Inserts

See Carbide Insert Catalog for a complete list of Insert Profiles available from Rottler Manufacturing.

Special Profiles

Special Profile Cutter Inserts can be manufactured to your exact specifications and can include a combination of angles and radius blends.

There is three different style insert blanks.

A - Style Blank insert, RCA is a small insert for all standard applications.

B - Style Blank insert, RCB in design for long profiles like High Performances profiles with multi angles o Radius or other special applications

C - Style Blank insert, RCC is a much thicker insert for Heavy Duty tooling and can be use for hard seat materials (will work only on the Large Inserts holders series 3000 style insert holders, for the 20.00mm tooling)

Special Order - Special Profile Carbide Cutter Bits are generally considered to be "Customer Proprietary". These are uniquely numbered, exclusively for the ordering customer; prices will vary depending on quantities and additional charge for initial run.

Call us for a quote.

RT312 Insert, triangular positive rake, 3/8 1/32" (.787mm) radius, for the TH3000 series insert holder and

RT212 Insert, triangular positive rake, 1/4" (6.35mm) 1/32 " radius for the TH2000 series, for hard seat materials applications (Counterboring and straight angles only)

Carbide Pilots

See Carbide Pilot catalog for a complete list of Pilots available.

Rottler Solid Fixed Carbide Pilots are manufactured from fine grain sintered tungsten carbide and are ground to a very high degree of accuracy, straightness and surface finish - designed for a life time of precision machining!

The part number of the pilot represents the actual diameter in metric of the straight/parallel part of the pilot where the pilot fits into the valve guide.

For example:

UCP0700 means that the diameter of the part of the pilot that goes into the valve guide is 7.00mm (0.2756")

UCP1270 means that the diameter of the part of the pilot that goes into the valve guide is 12.70mm (0.5000")

Pilots are available in increments of .01mm (0.0004"). Normally, a small amount of clearance approx .01mm (0.0004") is required between the pilot and the valve guide.

Most new valve guides are manufactured to a nominal size and the valve stem diameters are manufactured to be smaller than the nominal size to allow clearance for heat expansion of the valve stem when the engine is operating. For example: a 7mm valve guide has an internal diameter of exactly 7.00mm (.2756") The valve stem diameter of the intake valve is 6.98mm (.2748") and the exhaust is 6.96mm (.2740"). In order for the pilot to fit most all valve guides, the first choice could be UCP0699 to give .01mm (0.0004") clearance. If the valve guide is used and has some wear, then the second choice of pilot could be UCP0700(0.2756").

Rottler makes 3 sizes of shanks of pilots:

6.00mm (0.2362") for small valves guides 6mm (0.236") and below. The part number for these pilots is UCPM.

0.375" (9.52mm) for common size valve guides, 6-14mm (.236-.625"). The part number for these pilots is UCP.

20mm (0.7874mm) for large valve guides for SG8M0A machine. These pilots are made to order specifications.

SG100XY MACHINE ASSEMBLY PARTS

Base Table and Riser Assembly

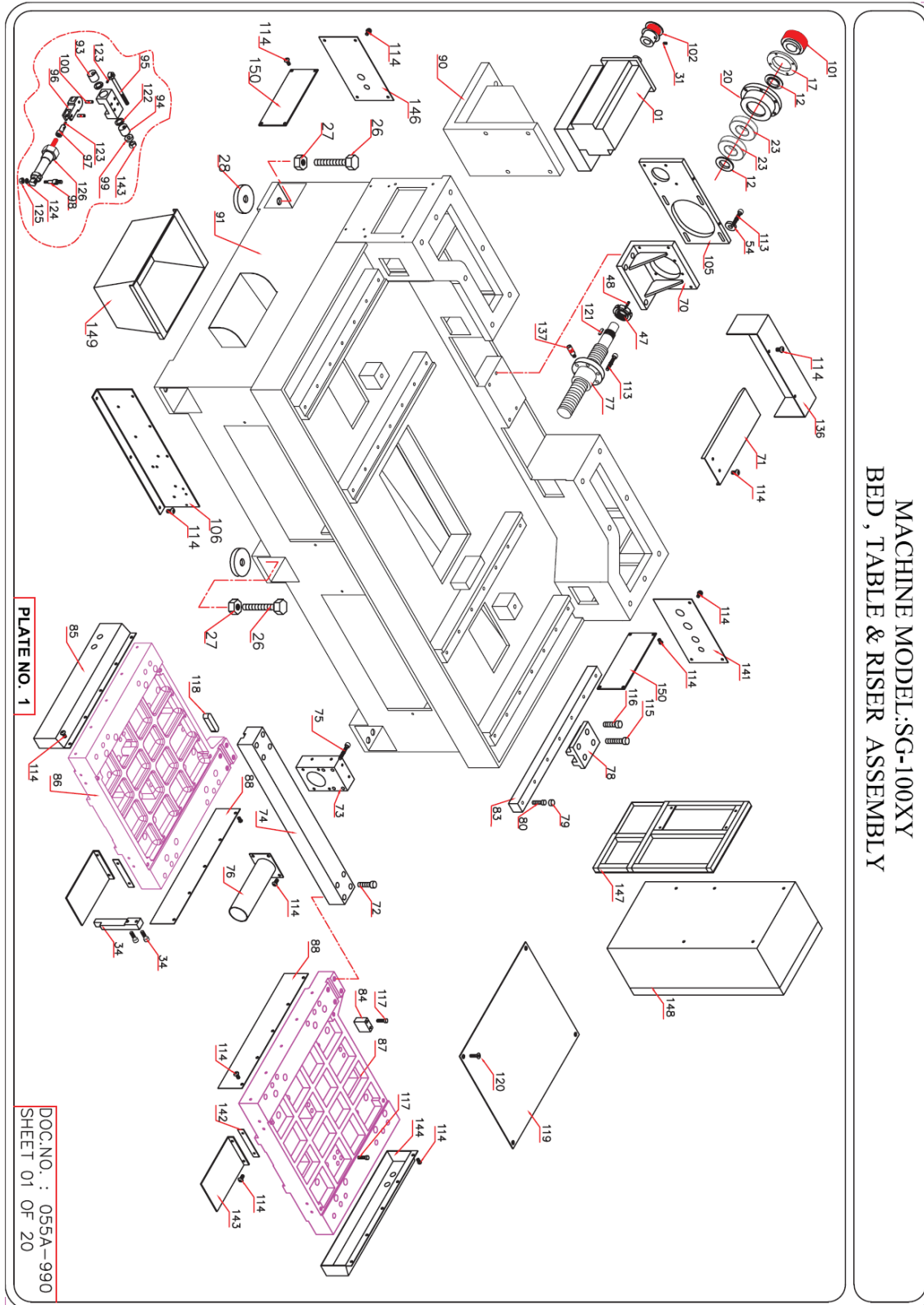

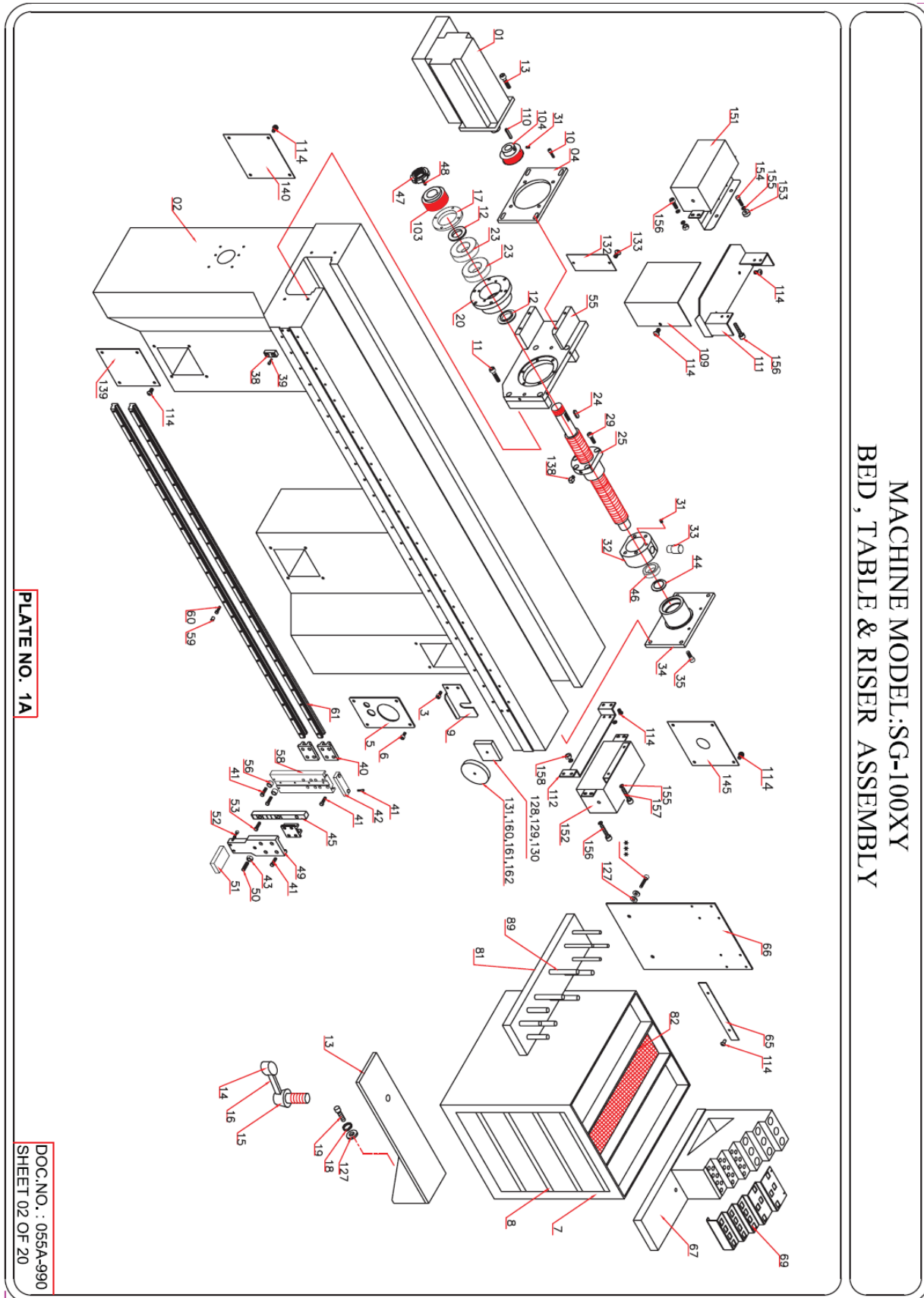

S. NO.	PART NO.	BIN NO. (SG-100XY)	BIN NO. (SG-80MTS)	BIN NO. (SG-9MTS)	DESCRIPTION	QTY
1		100XY-101			A.C. SERVO MOTOR BSM-80-C-375-AB2	2
2	055A-023	100XY-102			RISER	1
3		100XY-103			BUTTON HEAD SCREW (M6x10)	2
4	055A-071	100XY-104			MOTOR FLANGE (X)	1
5	055A-546		80MTS-105		NAME PLATE	1
6			80MTS-106		BUTTON HEAD SCREW (M6x12)	4
7	055A-760		80MTS-107		TOOL CABINET	1
8			80MTS-108		TOOL TRAY	4
9	055A-153	100XY-109			BRACKET	1
10		100XY-110			AL. HEAD SCREW (M6x20)	4
11		100XY-111			AL. HEAD SCREW (M8x50)	4
12	055A-055	100XY-112			BEARING SPACER	4
13		100XY-113			AL. HEAD SCREW (M6x16)	4
14	430-802			9-MTS-114	KNOB (M8x25MM O.D.)	1
15	430-817-1			9-MTS-115	CLAMP PIN	1
16	430-823			9-MTS-116	CLAMP LEVER	1
17	055A-054	100XY-117			BRG. RETAINER	2
18	VGS-804			9-MTS-118	SPRING WASHER (M8)	1
19	VGS-803			9-MTS-119	AL. HEAD SCREW (M8x30)	1
20	055A-053	100XY-120			BEARING HOUSING	2
21						
22						
23		100XY-123			ANG. CONTACT BRG. (30x62x16)	4
24		100XY-124			KEY (8x7x25)	1
25	055A-067	100XY-125			LONG BALL SCREW	1
26	430-818			9-MTS-126	LEVELING BOLT (M16x75)	8
27	430-818-A			9-MTS-127	HEX NUT (M16)	8
28	430-819			9-MTS-128	PAD	8
29		100XY-129			ALLEN HEAD SCREW M8x20	4
30		100XY-130			ALLEN HEAD GRUB SCREW M8x20	2
31		100XY-131			ALLEN HEAD GRUB SCREW M6x10	3
32	055A-069	100XY-132			BALL NUT (X)	1
33	055A-070	100XY-133			BALL NUT PIN	1
34	055A-068	100XY-134			BEARING HOUSING (X)	1
35		100XY-135			ALLEN HEAD SCREW (M8x30)	4
36						
37						
38	055A-077	100XY-138			RISEN STOPPER	2
39		100XY-139			ALLEN HEAD SCREW (M6x12)	4
40		100XY-140			CARRIAGE	6
41		100XY-141			ALLEN HEAD SCREW (M5x12)	16
42	055A-075	100XY-142			TOP STOPPER	2
43		100XY-143			NUT (M8)	4
44		100XY-144			INTERNAL CIRCLIP	1
45	055A-152	100XY-145			MSA 20S-SS+RAIL170	2
46		100XY-146			BAL BRG (6006-2RS)(30x45x13)	1
47	055A-406		80MTS-402		SHAFT NUT	1
48			80MTS-403		ALLEN GRUB SCREW (M5x8)	1
49	055A-073	100XY-149			SLIDING PLATE	2
50		100XY-150			M6 BALL PLUNGER SCREW	2
51	055A-076	100XY-151			STOPPER	2
52		100XY-152			ALLEN HEAD SCREW (M8x45)	4
53		100XY-153			ALLEN HEAD SCREW (M5x16)	8

S. NO.	PART NO.	BIN NO. (SG-100XY)	BIN NO. (SG-80MTS)	BIN NO. (SG-9MTS)	DESCRIPTION	QTY
54		100XY-154			PLAIN WASHER (M8)	4
55	055A-064	100XY-155			MOTOR BKT. (X)	1
56	055A-074	100XY-156			BOTTOM STOPPER	4
57						
58	055A-072	100XY-158			SUPPORT PLATE	2
59		100XY-159			PLUG (M8)	46
60		100XY-160			ALLEN HEAD SCREW (M4x20)	46
61		100XY-161			RAIL SLIDE	2
62						
63						
64						
65	430-839-4			9-MTS-165	NAME PLATE	1
66	055A-757		80MTS-166		SUPPORT PLATE	1
67	055A-756		80MTS-167		STAND	1
68						
69	055A-758		80MTS-169		PILOT STAND	1
70	055A-051	100XY-170			CROSS BRACKET	1
71	055A-087	100XY-171			REAR SCREW COVER (Y)	1
72		100XY-172			ALLEN HEAD SCREW (M12x60)	8
73	055A-057	100XY-173			NUT BRACKET (Y)	1
74	055A-050	100XY-174			CROSS MEMBER	1
75		100XY-175			ALLEN HEAD SCREW (M8x50)	4
76		100XY-176			FRONT SCREW COVER	1
77		100XY-177			CROSS BALL SCREW	1
78		100XY-178			CARRIAGE BLOCK & WIPER	8
79		100XY-179			PLUG	28
80		100XY-180			ALLEN HEAD SCREW (M6x25)	28
81	055A-759		80MTS-181		TOOL BOARD (L.H.) WITH PINS	1
82	055A-755		80MTS-182		RUBBER SHEET	1
83		100XY-183			RAIL SLIDE	4
84	055A-035	100XY-184			STOPPER	4
85	055A-082	100XY-185			TABLE SIDE COVER (L.H.)	1
86	055A-025	100XY-186			L.H. CROSS TABLE	1
87	055A-024	100XY-187			R.H. CROSS TABLE	1
88	055A-083	100XY-188			TABLE SIDE COVER	2
89	055A-766		80MTS-189		PIN	4
90	055A-048	100XY-190			CABINET SUPPORT	3
91	055A-047	100XY-191			CABINET	1
92	055A-026	100XY-192			CLAMPING BRACKET	2
93	055A-027	100XY-193			CLAMPING PAD	2
94	055A-028	100XY-194			CLAMPING PAD	2
95	055A-029	100XY-195			CLAMPING BOLT	2
96	055A-030	100XY-196			CLAMPING LEVER	2
97	055A-031	100XY-197			PIN JOINT	2
98	055A-032	100XY-198			CYL. PIVOT	2
99	055A-033	100XY-199			SPACER	2
100	055A-034	100XY-1100			CYL. PIN	4
101	055A-145	100XY-1101			SCREW PULLEY (Y)	1
102	055A-146	100XY-1102			MOTOR PULLEY (Y)	1
103	055A-065	100XY-1103			SCREW PULLEY (X)	1
104	055A-066	100XY-1104			MOTOR PULLEY (X)	1
105	055A-052	100XY-1105			MOTOR SUPPORT	1
106	055A-144	100XY-1106			BRACKET	2
107						

S. NO.	PART NO.	BIN NO. (SG-100XY)	BIN NO. (SG-80MTS)	BIN NO. (SG-9MTS)	DESCRIPTION	QTY
108						
109	055A-088	100XY-1109			BRACKET COVER (X)	1
110		100XY-1110			KEY (X)	1
111	055A-091	100XY-1111			LEFT RISER STOPPER	1
112	055A-092	100XY-1112			RIGHT RISER STOPPER	1
113		100XY-1113			ALLEN HEAD SCREW (M8x25)	13
114		100XY-1114			BUTTON HEAD SCREW (M6x10)	81
115		100XY-1115			ALLEN HEAD SCREW (M10x65)	16
116		100XY-1116			ALLEN HEAD SCREW (M10x35)	16
117		100XY-1117			ALLEN HEAD SCREW (M6x40)	16
118		100XY-1118			PARALLEL KEY (0.625"x0.625"x2.5")	2
119	055A-081	100XY-1119			TABLE COVER	2
120		100XY-1120			CSK HEAD SCREW (M6x10)	8
121		100XY-1121			KEY (8x7x22)	1
122		100XY-1122			O-RING	4
123		100XY-1123			ALLEN HEAD GRUB SCREW (M4x6)	2
124		100XY-1124			WASHER (M6)	2
125		100XY-1125			NUT (M6)	4
126	DSNU 20-50-P-A	100XY-1126			PNEUMATIC CYL. (19210-FESTO) WITH SENSOR & MTG. KIT	2
127		100XY-1127			WASHER (M8)	5
128	101A-109			9-MTS-166	VACUUM PAD	1
129	101A-110			9-MTS-167	VACUUM PAD	1
130	101A-111			9-MTS-168	VACUUM PAD	1
131	101A-112			9-MTS-169	VACUUM PAD	1
132	055A-155	100XY-1132			BELT COVER	1
133		100XY-1133			BUTTON HEAD SCREW (M5x10)	2
134	055A-157	100XY-1134			STOPPER FLAT	1
135		100XY-1135			ALLEN HEAD SCREW (M6x--)	2
136	055A-156	100XY-1136			BELT COVER	1
137	055A-162	100XY-1137			OIL FITTING FOR Y-AXIS SCREW	1
138	055A-163	100XY-1138			OIL FITTING FOR X-AXIS SCREW	1
139	055A-084	100XY-1139			COVER (FRONT SIDE)	2
140	055A-085	100XY-1140			COVER (BACK SIDE)(L.H.)	1
141	055A-095	100XY-1141			CABINET COVER (BACK SIDE)(R.H.)	1
142	055A-165	100XY-1142			CLAMP STRIP	4
143	055A-166	100XY-1143			FLAP GUARD	4
144	055A-167	100XY-1144			TABLE SIDE COVER (R.H.)	1
145	055A-168	100XY-1145			COVER (BACK SIDE)(R.H.)	1
146	055A-169	100XY-1146			CABINET COVER (BACK SIDE)(L.H.)	1
147	055A-891-1	100XY-1147			PANEL MTG. FRAME	1
148	055A-891	100XY-1148			PANEL BOX	1
149	055A-892	100XY-1149			CHIP TRAY	1
150	055A-893	100XY-1150			CABINET SIDE COVER	2
151	440-284-L			10XY-1160	COVER	1
152	440-284-R			10XY-1108	COVER	1
153	440-285-1			10XY-1109	SPACER	1
154				10XY-1-110	ALLEN HEAD SCREW (M5x25)	2
155		100XY-1155			M.S. WASHER (M5)	20
156				10XY-1-111	ALLEN HEAD SCREW (M5x12)	8
157		100XY-1157			ALLEN HEAD SCREW (M5x16)	2
158		100XY-1158			HEX NUT (M5)	8
160	101A-113			9-MTS-170	VACUUM PAD	1
161	101A-114			9-MTS-171	VACUUM PAD	1
162	101A-115			9-MTS-172	VACUUM PAD	1

Base Assembly

MACHINE MODEL:SG-100XY BASE ASSEMBLY

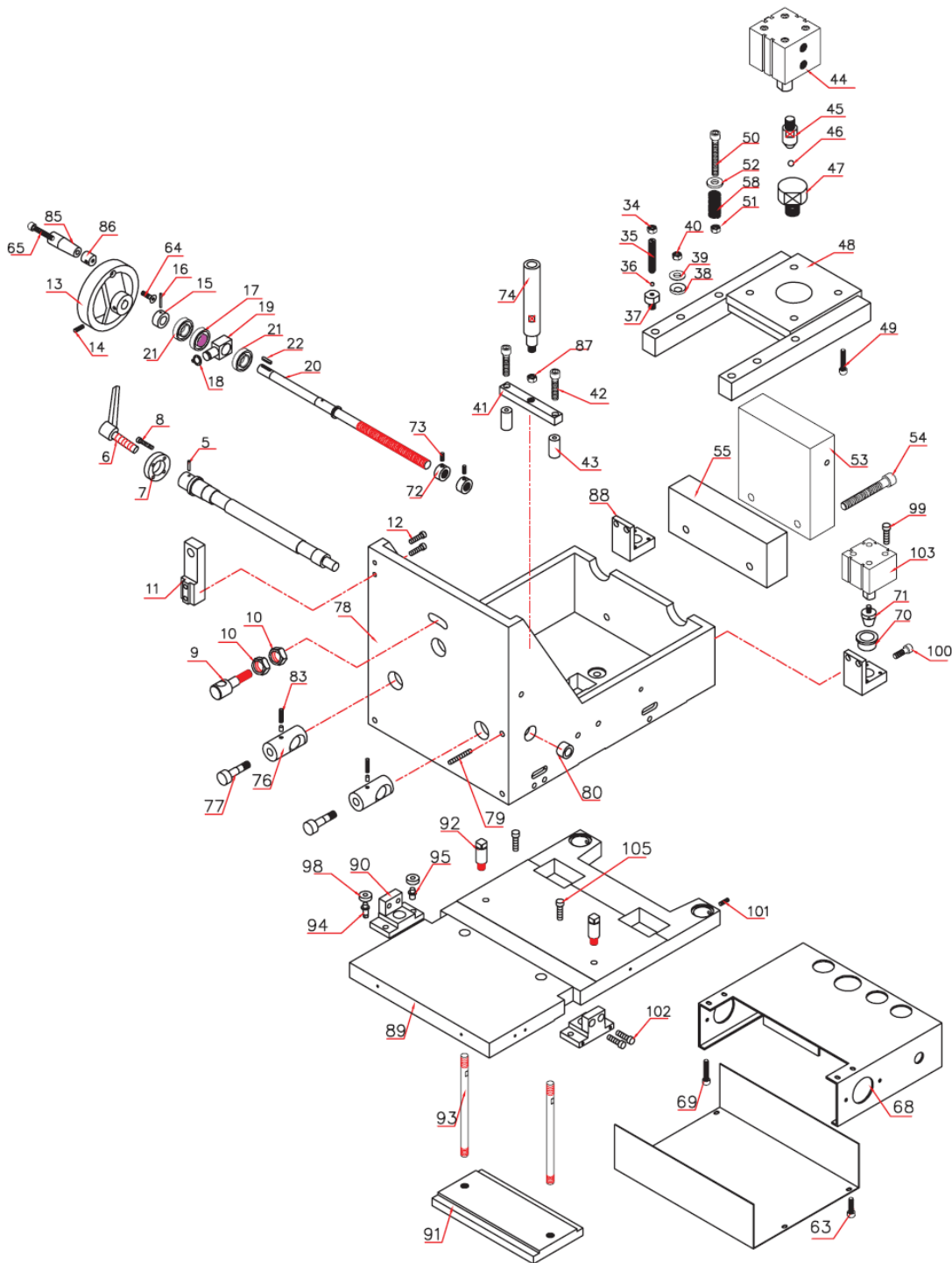

PLATE NO. 2

DOC. NO. 055A-990
SHEET 6 OF 20

S. NO.	PART NO.	BIN NO. (SG-100XY)	BIN NO. (SG-80MTS)	BIN NO. (SG-9MTS)	DESCRIPTION	QTY
1						
2						
3						
4						
5			80MTS-205		CYLINDRICAL PIN (DIA 1/8" x 1 1/8"L)	1
6			80MTS-206		ADJUSTABLE HANDLE	1
7	055A-321		80MTS-207		SPACER HOUSING	1
8			80MTS-208		ALLEN SCREW (M6x16)	4
9	055A-264		80MTS-209		LOCATING BOLT	1
10	055A-320		80MTS-210		NUT	2
11	055A-327		80MTS-211		SCREW BLOCK	1
12			80MTS-212		ALLEN SCREW (M8x40)	2
13	055A-311		80MTS-213		HAND WHEEL	1
14			80MTS-214		ALLEN GRUB SCREW (M6x10)	1
15	055A-309		80MTS-215		SPACER	1
16			80MTS-216		SPRING DOWEL (DIA 1/8" x 1 1/8"L)	1
17	HK1612D		80MTS-217		NEEDLE ROLLER BEARING (NTN-18408)	1
18			80MTS-218		EXT. CIRCLIP (A16)	1
19	055A-304		80MTS-219		GUIDE PIN	1
20	055A-310		80MTS-220		INCLINATION ROD	1
21			80MTS-221		NEEDLE THRUST BEARNG	2
22			80MTS-222		PARALLEL KEY (3/16" x 3/16" x 7/8")	1
23						
24						
25						
26						
27						
28						
29						
30						
31						
32						
33						
34			80MTS-234		HEX NUT (M12)	2
35	055A-308		80MTS-235		SET SCREW	2
36			80MTS-236		STEEL BALL (DIA 1/4")	2
37	055A-301		80MTS-237		PIVOT	2
38	055A-323		80MTS-238		SPHERICAL WASHER	6
39	055A-324		80MTS-239		SPHERICAL WASHER	6
40			80MTS-240		NYLOCK HEX NUT (M12)	2
41	055A-316		80MTS-241		SWIVEL BRACKET	1
42			80MTS-242		ALLEN SCREW (M6x55)	2
43	055A-315		80MTS-243		SPACER	2
44	#125-15-1-PA		80MTS-244		PNEUMATIC CYLINDER (536393)	1
45	055A-306		80MTS-245		PIVOT PIN	1
46			80MTS-246		STEEL BAL (DIA 3/8")	1
47	055A-303		80MTS-247		BALL SUPPORT	1
48	055A-322		80MTS-248		CLAMPING BRACKET	1
49			80MTS-249		ALLEN SCREW (M12x30)	4
50			80MTS-250		HEX HEAD SCREW (M8x100)	2
51			80MTS-251		HEX NUT (M8)	2
52			80MTS-252		WASHER (M8)	2
53	055A-049	100XY-253			WEIGHT	1
54				80A-254	ALLEN SCREW (M12x110)	2

S. NO.	PART NO.	BIN NO. (SG-100XY)	BIN NO. (SG-80MTS)	BIN NO. (SG-9MTS)	DESCRIPTION	QTY
55	055A-158	100XY-255			SPACING PLATE	1
56						
57						
58	282580		80MTS-258		COMP. SPRING	2
59						
60						
61						
62						
63				80A-2152	AL. HEAD SCREW (M6x10)	2
64				80A-2155	CSK HEAD SCREW (M6x15)	1
65				80A-2156	AL. HEAD SCREW (M8x20)	1
66						
67						
68	055A-710	100XY-268			CABLE TRAY WITH COVER	1EA.
69		100XY-269			ALLEN HEAD SCREW (M6x12)	4
70	440-240				TAPER BUSH	2
71	440-281				CEN. CONE	2
72	055A-342		80MTS-272		STOP COLLAR	2
73			80MTS-273		ALLEN SET SCREW (M6x12)	2
74	055A-341		80MTS-274		TIE ROD SUPPORT	1
75	055A-334		80MTS-275		ECCENTRIC SHAFT	1
76	055A-336		80MTS-276		CLAMPING BLOCK	2
77	055A-339		80MTS-277		CLAMPING BOLT	2
78	055A-015	100XY-278			BASE	1
79			80MTS-279		GRUB SCREW (M6x16)	2
80	055A-345		80MTS-280		ECCENTRIC BUSH	1
81						
82						
83						
84						
85	055A-888		80MTS-285		KNOB	1
86	055A-889		80MTS-286		PLUG (LEVER)	1
87			80MTS-287		HEX NUT (M12)	1
88	055A-022	100XY-288			CYL. BKT.	2
89	055A-059	100XY-289			SUPPORT PLATE (X)	1
90	055A-060	100XY-290			BEARING PLATE	2
91	055A-061	100XY-291			CLAMP PLATE	1
92	055A-062	100XY-292			THREADED PIN	2
93	055A-063	100XY-293			CLAMPING STUD	2
94	055A-044	100XY-294			ECCENTRIC PIN	2
95	055A-045	100XY-295			ECCENTRIC PIN	2
96						
97						
98		100XY-298			BALL BRG. (608-2RS)(8x22x7)	4
99		100XY-2150			ALLEN HEAD SCREW (M6x16)	4
100		100XY-2151			ALLEN HEAD SCREW (M5x50)	2
101		100XY-2153			ALLEN HEAD GRUB SCREW (M6x10)	2
102		100XY-2154			ALLEN HEAD SCREW (M8x16)	4
103		100XY-2157			AIR CYL. (32x15)	2
104						
105		100XY-2159			ALLEN HEAD SCREW (M16x60)	2
106						
107						
108						

Spindle Assembly

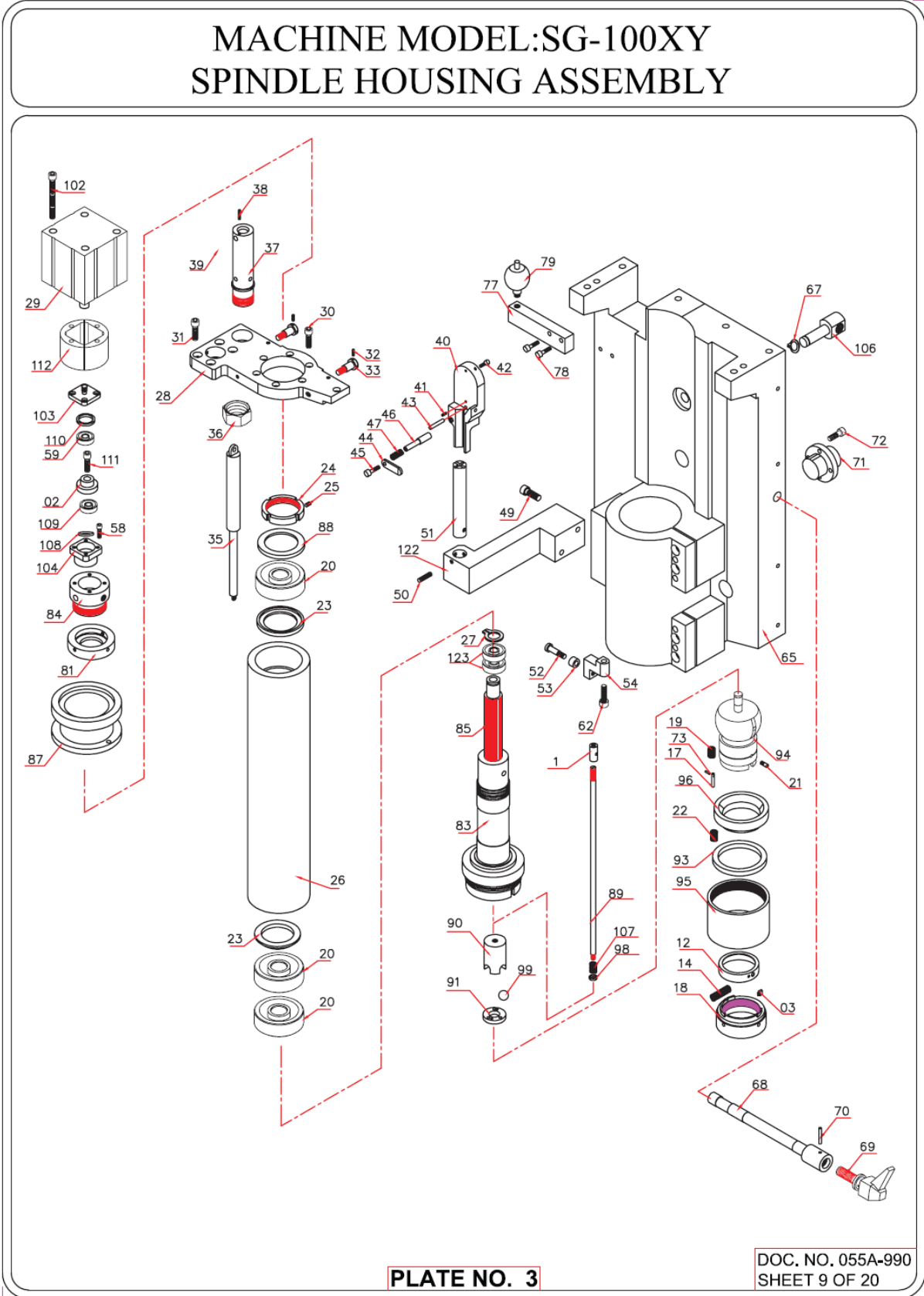

S. NO.	PART NO.	BIN NO. (SG-100XY)	BIN NO. (SG-80MTS)	BIN NO. (SG-80A)	BIN NO. (SG-9MTS)	DESCRIPTION	QTY
1	NCL-72-1				9MTS-301-D	ROTATING PIN	1
2	NCL-72-2				9MTS-301-F	BEARING HOLDER	1
3	KS-08-02				9MTS-305	PAD	1
4							
5							
6							
7							
8							
9							
10							
11							
12	KS-09-06		80MTS-312			COVER	1
13							
14	KS-09-03		80MTS-314			COMP. SPRING	2
15							
16							
17	KS-08-05				9MTS-318	PIN	1
18	KS-09-07		80MTS-318			NUT	1
19	KS-08-01				9MTS-319	COMP. SPRING	1
20			80MTS-320			ANG. CONT. BALL BRG (50x72x12)	3
21	KS-08-01				9MTS-320	STOP PIN	1
22	5203-3				9MTS-322	SPRING	3
23	055A-181	100MTS-323				BRG SPACER	2
24	055A-106		80MTS-324			SPINDLE NUT	1
25			80MTS-325			ALLEN GRUB SCREW (M5x8)	2
26	055A-170	100XY-326				QUILL	1
27					9MTS-327	EXT. CIRCLIP (DIA 20MM)	1
28	055A-190			80A-328		STOP PLATE	1
29	536279- B008				9MTS-329	ACTUATING CYL. (AND-32- 10-I-P)	1
30			80MTS-330			ALLEN SCREW (M6x25)	6
31				80A-331		ALLEN SCREW (M8x20)	4
32			80MTS-332			ALLEN GRUB SCREW (M5x6)	2
33	055A-121		80MTS-333			ADJUSTING SCREW	2
34							1
35			80MTS-335			COMP. GAS SPRING	1
36	055A-104		80MTS-336			NUT	1
37	055A-111		80MTS-337			GAS SPRING SUPPORT	1
38			80MTS-338			ALLEN GRUB SCREW (M4x6)	1
39	055A-113		80MTS-339			CYL. PIN	1
40	055A-236		80MTS-340			LEVEL BLOCK	1
41			80MTS-341			ALLEN GRUB SCREW (M6x16)	1
42			80MTS-342			ALLEN SCREW (6-32x5/8"LG)	2
43			80MTS-343			CYL. PIN (DIA3/16" X 1 1/8"LG)	1
44	055A-237		80MTS-344			CLAMP	1
45			80MTS-345			ALLEN SCREW (M5x12)	1
46	055A-238		80MTS-346			CLAMP PIN	1
47	055A-240		80MTS-347			SPRING	1
48							
49			80MTS-349			ALLEN SCREW (M8x50)	2
50			80MTS-350			ALLEN GRUB SCREW (M6x12)	3
51	055A-239		80MTS-351			CLAMP	1
52	055A-247		80MTS-352			GAS SPRING SCREW	1

S. NO.	PART NO.	BIN NO. (SG-100XY & MTS)	BIN NO. (SG-80MTS)	BIN NO. (SG-80A)	BIN NO. (SG-9MTS)	DESCRIPTION	QTY
53	055A-248		80MTS-353			GAS SPRING SPACER	1
54	055A-295			80A-354		GAS SPRING HOLDER	1
55							
56							
57							
58					9MTS-358	ALLEN CAP SCREW (M5x12)	4
59	6001-2RS-1				9MTS-359	BALL BRG. (12x28x8)	1
60							
61							
62				80A-362		ALLEN CAP SCREW (M6x30)	1
63							
64							
65	055A-297			80A-365		SPINDLE HOUSING	1
66							
67			80MTS-367			EXT. CIRCLIP (A16)	1
68	055A-268		80MTS-368			ECCENTRIC CLAMP	1
69			80MTS-369			ADJUSTABLE HANDLE	1
70			80MTS-370			CYL. PIN (DIA 1/8" X 1 1/8"LG)	1
71	055A-219		80MTS-371			PIVOT PIN	1
72			80MTS-372			ALLEN SCREW (M6x12)	4
73			80MTS-373			PIN (DIA 0.093"x0.350"LG)	1
74							
75							
76							
77	055A-337			80A-377		LUB, FEEDER	1
78				80A-378		ALLEN HEAD SCREW (M6x30)	2
79				80A-379		OILER	1
80							
81	NCL-70-2				9MTS-381	CLAMP NUT	1
82							
83	055A-176-1	100MTS-383				SPINDLE	1
84	NCL-70-1				9MTS-384	BEARING HOUSING	1
85	055A-176-2	100MTS-385				SPLINE SHAFT	1
86							
87	055A-187	100MTS-387				TOP STOPPER	1
88	055A-182	100MTS-388				BRG. SPACER	1
89	055A-138	100MTS-389				THREAD ROD	1
90	055A-177	100MTS-390				BALL CAGE	1
91	055A-178	100MTS-391				BALL SPACER	1
92							
93	055A-175	100MTS-393				SPRING SPACER	1
94	055A-172	100MTS-394				DRIVE ADAPTER	1
95	055A-173	100MTS-395				SPHERE CAP	1
96	055A-174	100MTS-396				LOWER CONE	1
97	055A-154	100XY-397				SPACING RING	1
98	055A-149	100MTS-398				SPACER	1
99		100MTS-399				STEEL BALL (DIA 0.500")	3
100							
101							
102					9MTS-3102	ALLEN HEAD SCREW (M5x95)	4
103	NC-141				9MTS-3103	SUPPORT PLATE	1

S. NO.	PART NO.	BIN NO. (SG-100XY & MTS)	BIN NO. (SG-80MTS)	BIN NO. (SG-80A)	BIN NO. (SG-9MTS)	DESCRIPTION	QTY
104	NC-140				9MTS-3104	BEARING HOUSING	1
105							
106	055A-270		80MTS-3106			NUT (M)	1
107	AS-1021-1				9MTS-3107	SPRING (033-KIT)	1
108	NC-145				9MTS-3108	O-RING	1
109	NC-144				9MTS-3109	THRUST BEARING (12x26x4)	1
110	NC-142				9MTS-3110	SPACER	1
111					9MTS-3111	ALLEN HEAD SCREW (M6x16)	4
112	NC-143				9MTS-3112	SPACING BLOCK	1
113							
114							
115							
116							
117							
118							
119							
120							
121							
122	055A-282		80MTS-3122			LEVEL SUPPORT	1
123	6004-2RS				9MTS-383	BALL BEARING (20x42x12)	2

Transmission Assembly

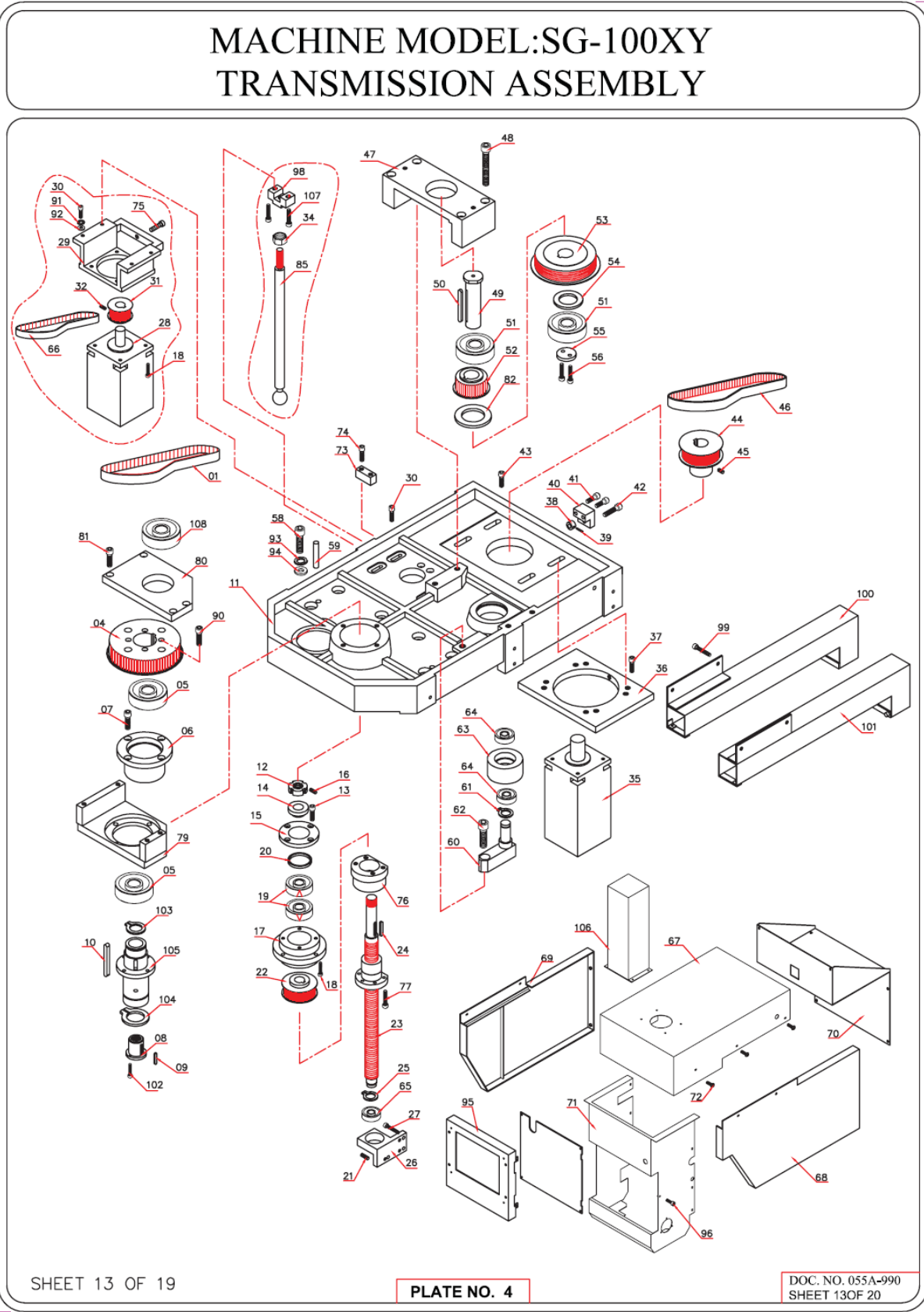

SHEET 13 OF 19

PLATE NO. 4

DOC. NO. 055A-990
SHEET 13 OF 20

S. NO.	PART NO.	BIN NO. (SG-100XY & MTS)	BIN NO. (SG-80MTS)	BIN NO. (SG-9MTS)	DESCRIPTION	QTY
1				80A-401	SPINDLE POLY CHAIN BELT	1
2						
3						
4	055A-184	100MTS-404			SPINDLE PULLEY	1
5	6910	100MTS-405			BALL BEARING (50x72x12-2RS)	2
6	055A-185	100MTS-406			BEARING HOUSING	1
7			80MTS-407		ALLEN SCREW (M8x25)	4
8	055A-186	100MTS-408			SPLINE BUSH	1
9			80MTS-306		PARALLEL KEY (1/4"x 1/4"x1 1/2")	1
10			80MTS-410		PARALLEL KEY (5/16"x5/16"x1 1/4")	1
11	055A-255			80A-411	TOP PLATE	1
12	055A-422			80A-412	RING NUT	1
13			80MTS-413		ALLEN HEAD SCREW (M6x16)	1
14	055A-430			80A-414	BEARING SPACER	1
15	055A-442			80A-415	BEARING COVER	1
16				80A-416	ALLEN HD. GRUB SCREW (M6x12)	4
17	055A-441			80A-417	BEARING HOUSING	1
18				80A-418	ALLEN SCREW (M6x16)	8
19				80A-419	ANG. CONTACT BALL BRG. (7204)	2
20	055A-443			80A-420	BEARING SPACER	1
21				80A-421	ALLEN GRUB SCREW (M5x8)	4
22	055A-427			80A-422	PULLEY	1
23	055A-480			80A-423	BALL SCREW	1
24				80A-424	PARALLEL KEY (1/4"x1/4"x1 5/16")	1
25				80A-425	EXT. CIRCLIP (A12)	1
26	055A-479			80A-426	BEARING HOUSING	1
27				80A-427	ALLEN SCREW (M6x25)	4
28				80A-428	Z-AXIS MOTOR	1
29	055A-405			80A-429	MOTOR SUPPORT	1
30				80A-430	ALLEN SCREW (M6x25)	8
31	055A-409			80A-431	MOTOR PULLEY	1
32				80A-432	ALLEN GRUB SCREW (M5x8)	1
33						
34			80MTS-434		HEX NUT (M12)	1
35				80A-435	SPINDLE MOTOR	1
36	055A-407			80A-436	MOTOR PLATE	1
37			80MTS-437		ALLEN SCREW (M10x25)	4
38	055A-254		80MTS-438		SPACER	1
39			80MTS-439		CYL. PIN (DIA. 1/8" X 5/8" LG)	1
40	055A-253		80MTS-440		ADJUSTING BLOCK	1
41			80MTS-441		ALLEN SCREW (M6x30)	2
42			80MTS-442		ALLEN SCREW (M8x50)	2
43			80MTS-443		ALLEN SCREW (M10x30)	4
44	055A-438			80A-444	MOTOR PULLEY	1
45			80MTS-445		ALLEN GRUB SCREW (M6x10)	1
46			80MTS-446		MOTOR POLY CHAIN BELT	1
47	055A-256		80MTS-447		BEARING SUPPORT	1
48			80MTS-448		ALLEN SCREW (M10x75)	4
49	055A-440		80MTS-449		INT. SHAFT	1
50			80MTS-450		PARALLEL KEY (5/16"x5/16"x3")	1
51			80MTS-451		BALL BEARING (6206)	2
52	055A-448		80MTS-452		UPPER INT. PULLEY	1
53	055A-439		80MTS-453		LOWER INT. PULLEY	1
54			80MTS-454		INT. CIRCLIP (B62)	1

S. NO.	PART NO.	BIN NO. (SG-100XY & MTS)	BIN NO. (SG-80MTS)	BIN NO. (SG-80A)	DESCRIPTION	QTY
55	055A-435		80MTS-455		BEARING SPACER	1
56			80MTS-456		ALLEN SCREW (M6x15)	2
57						
58			80MTS-458		ALLEN SCREW (M10x35)	6
59			80MTS-459		CYL. PIN	2
60	055A-478		80MTS-460		IDLER SUPPORT	1
61			80MTS-461		EXT. CIRCLIP (A20)	1
62			80MTS-462		ALLEN SCREW (M12x35)	1
63	055A-436		80MTS-463		IDLER PULLEY	1
64			80MTS-464		BALL BEARING (6004 LLU/2AS)	2
65				80A-465	BALL BEARING (6904-2RS)(20x37x9)	1
66				80A-466	TIMING BELT	1
67	055A-097	100XY-467			TOP COVER	1
68	055A-159	100XY-468			RIGHT COVER	1
69	055A-160	100XY-469			LEFT COVER	1
70	055A-161	100XY-470			BACK COVER	1
71	055A-098	100XY-471			FRONT COVER	1
72			80MTS-472		ALLEN BUTTON SCREW (M5x6)	26
73	055A-283			80A-473	BLOCK	1
74				80A-474	ALLEN HEAD SCREW (M8x25)	1
75				80A-475	ALLEN HEAD SCREW (M8x35)	1
76	055A-446			80A-476	BALL SCREW BRACKET	1
77				80A-477	ALLEN HEAD SCREW (M5x16)	5
78						
79	055A-474		80MTS-479		BEARING SUPPORT	1
80	055A-475		80MTS-480		BEARING COVER	1
81			80MTS-481		ALLEN HEAD CAP SCREW (M8x20)	4
82	055A-335		80MTS-482		PULLEY SPACER	1
83						
84						
85	055A-340		80MTS-485		PLATE SUPPORT	1
86						
87						
88						
89						
90		100MTS-490			ALLEN HAED SCREW (M6x25)	4
91				80A-491	SPRING WASHER (M6)	4
92				80A-492	LOCK WASHER (M6)	4
93		100MTS-493			SPRING WASHER (M10)	6
94		100MTS-494			LOCK WASHER (M10)	6
95	055A-714			80A-495	DUST COVER	
96				80A-496	ALLEN HEAD SCREW (M6x10)	4
97						
98	055A-220			80A-498	SUPPORT PLATE	1
99		100XY-499			ALLEN HEAD SCREW (M6x12)	4
100	055A-890-A	100XY-4100			CABLE CHANNEL (L.H.)	1
101	055A-890-B	100XY-4101			CABLE CHANNEL (R.H.)	1
102		100XY-4102			ALLEN HEAD SCREW (M4x12)	2
103		100MTS-4103			EXT. CIRCLIP (M35)	1
104		100MTS-4104			EXT. CIRCLIP (M48)	1
105	055A-183	100MTS-4105			DRIVER PULLEY	1
106	055A-099	100MTS-4106			CYL. COVER	1
107			80MTS-4107		ALLEN HEAD SCREW (M6x30)	2
108	6908	100MTS-4108			BALL BEARING (50x72x12-2RS)	1

Head Support Assembly

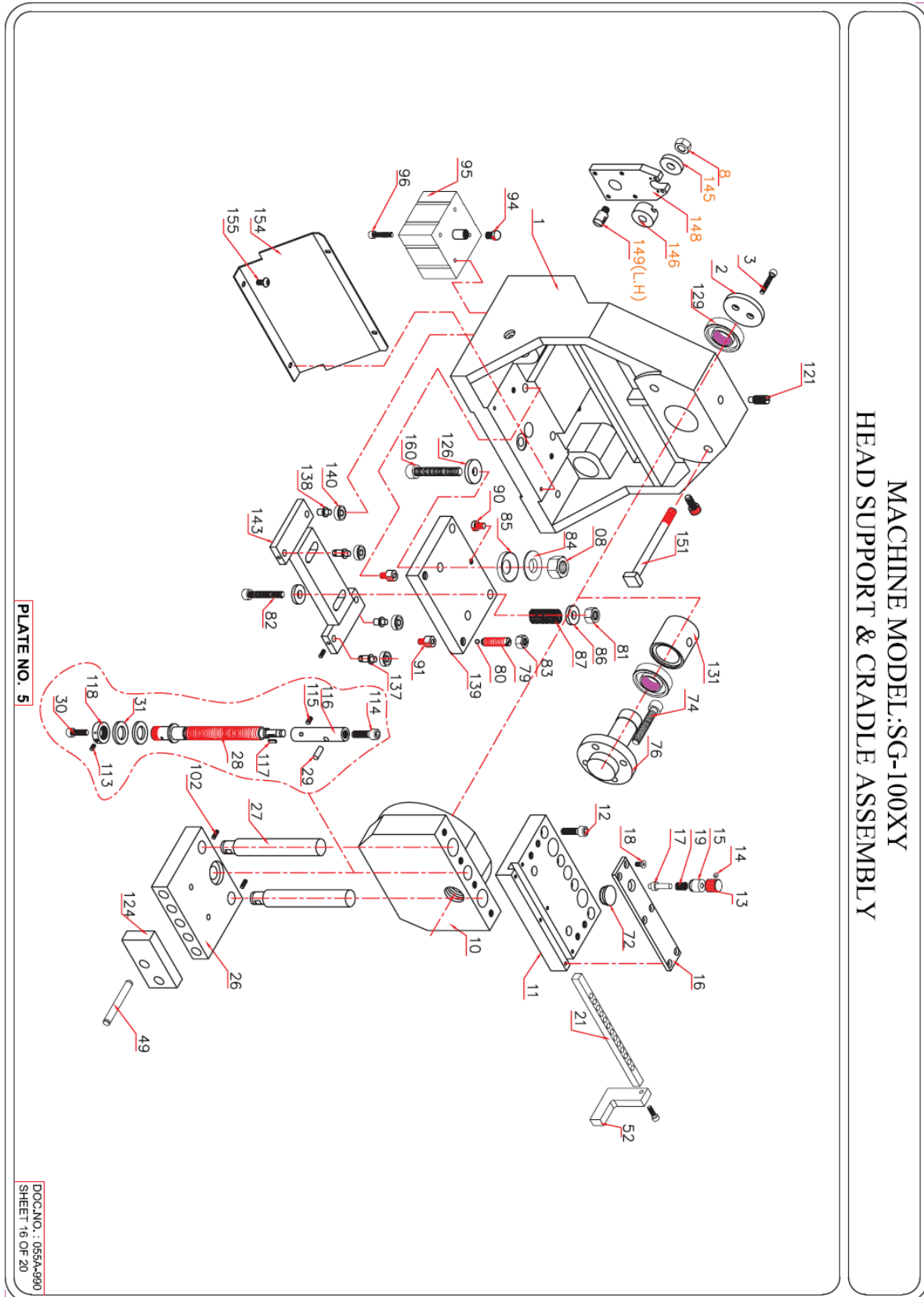

MACHINE MODEL:SG-100XY
HEAD SUPPORT & CRADLE ASSEMBLY

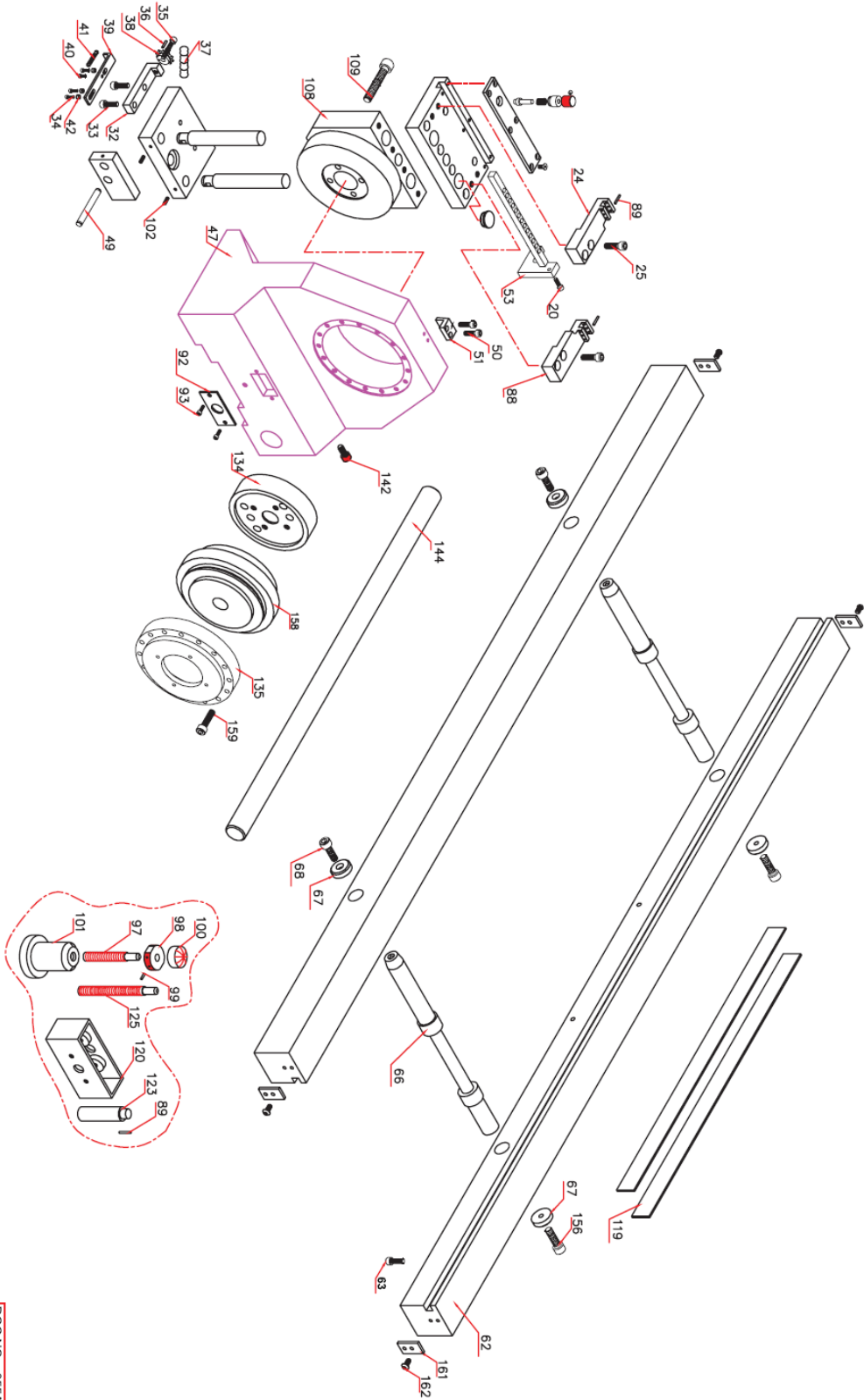

PLATE NO. 5A

DOC.NO.: 055A-4990
SHEET 18 OF 20

S. NO.	PART NO.	BIN NO. (SG-100XY)	BIN NO. (SG-80MTS)	BIN NO. (SG-9MTS)	DESCRIPTION	QTY
1	055A-037	100XY-501			LEFT CRADLE SUPPORT	1
2	055A-662		80MTS-502		SPACER	1
3			80MTS-503		ALLEN HEAD SCREW (M6x12)	2
4						
5						
6						
7						
8			80MTS-508		NYLOCK HEX NUT (M12)	6
9						
10	055A-657		80MTS-510		CRADLE HOLDER (LEFT)	1
11	055A-573		80MTS-511		SUPPORT PLATE	2
12			80MTS-512		ALLEN SCREW (M10x35)	8
13	430-918			9MTS-513	KNURLING COLLAR	2
14	430-917			9MTS-514	AL. GRUB SCREW (M6x6)	2
15	430-916			9MTS-515	PIN HOLDER	2
16	055A-527		80MTS-516		COVER PLATE	2
17	430-919			9MTS-517	PLUNGER	2
18				9MTS-512	ALLEN CSK SCREW (M5x12)	12
19	430-921			9MTS-516	SPRING (#100-057)	2
20	430-936			9MTS-520	AL. HD. SCREW (M6x20)	2
21	SF-108			9MTS-521	FLAT	2
22						
23						
24	055A-569		80MTS-524		CHAIN BLOCK-A	2
25			80MTS-525		ALLEN SCREW (M10x25)	8
26	055A-579		80MTS-526		CLAMP PLATE	2
27	055A-588		80MTS-527		GUIDE ROD	4
28	055A-638		80MTS-528		SCREW ROD	2
29			80MTS-529		CYL. PIN (DIA 4 x 20 LG)	2
30			80MTS-530		ALLEN HEAD SCREW (M12x25)	2
31			80MTS-531		NEEDLE THRUST BEARING (20x34x4)	4
32	055A-576		80MTS-532		SPROCKET SUPPORT	4
33			80MTS-533		ALLEN HEAD SCREW (M10x20)	8
34			80MTS-534		ALLEN BUTTON HD SCR W (M5x10)	12
35			80MTS-535		ALLEN SCREW (M8x20)	4
36			80MTS-536		DOWEL PIN (DIA 1/8" X 3/8" LG)	4
37			80MTS-537		ROLLER CHAIN	1
38	055A-556		80MTS-538		SPROCKET	4
39	055A-564		80MTS-539		TOP PLATE	4
40			80MTS-540		ALLEN BUTTON HD SCR W (M5x6)	4
41	055A-557		80MTS-541		TENSION SPRING	4
42	055A-565		80MTS-542		BUSH	12
43						
44						
45						
46	430-949			9MTS-542	PIVOT PIN	2
47	055A-038	100XY-547			RIGHT CRADLE SUPPORT	1
48						
49						
50		100XY-550			ALLEN SCREW (M5x20)	2
51	055A-151	100XY-551			ZERO MARK	1
52	430-937-1			9MTS-564	STOP PLATE (L.H.)	1
53	430-935-1			9MTS-563	STOP PLATE (R.H.)	1

S. NO.	PART NO.	BIN NO. (SG-100XY)	BIN NO. (SG-80MTS)	BIN NO. (SG-9MTS)	DESCRIPTION	QTY
54						
55						
56						
57						
58						
59						
60						
61						
62	055A-036	100XY-562			PARALLEL BAR	2
63		100XY-563			ALLEN SCREW (M12x65)	8
64						
65						
66	055A-042	100XY-566			GUIDE ROD	2
67	055A-560		80MTS-567		END COVER	4
68			80MTS-568		ALLEN SCREW (M8x16)	4
69						
70						
71						
72	055A-626		80MTS-572		PLUG	4
73						
74			80MTS-574		ALLEN SCREW (M10x20)	4
75						
76	055A-041	100XY-576			HOLDER SHAFT LEFT	1
77						
78						
79	055A-674		80MTS-579		SET-SCREW	4
80			80MTS-580		STEEL BALL (DIA 6MM)	4
81			80MTS-581		NYLOCK NUT (M8)	4
82			80MTS-582		ALLEN HEAD SCREW (M8x90)	4
83			80MTS-583		HEX NUT (M12)	2
84	055A-323		80MTS-584		SPHERICAL WASHER	4
85	055A-324		80MTS-585		SPHERICAL WASHER	4
86			80MTS-586		WASHER (M8)	8
87	282580		80MTS-587		COMP. SPRING	4
88	055A-625		80MTS-588		CHAIN BLOCK-B	2
89	055A-567		80MTS-589		PIN	12
90	055A-635		80MTS-590		PIVOT	2
91	055A-672		80MTS-591		PIVOT	4
92	055A-645		80MTS-592		VALVE PLATE	2
93			80MTS-593		ALLEN CSX SCREW (M6x12)	4
94	055A-673		80MTS-594		CYLINDER EXTENSION	2
95			80MTS-595		PNEUMATIC CYLINDER	2
96			80MTS-596		ALLEN HEAD SCREW (M6x70)	8
97	055A-682		80MTS-597		JACK SCREW	1
98	055A-683		80MTS-598		JACK COLLAR	2
99			80MTS-599		CYL. PIN (DIA 1/8" X 1 1/2" LG)	1
100	055A-681		80MTS-5100		JACK TOP	1
101	055A-680		80MTS-5101		JACK BASE	1
102			80MTS-5102		ALLEN GRUB SCREW (M6x6)	4
103						
104						
105						
106						
107						
108	055A-802-05	100XY-5108			CRADLE HOLDER (RIGHT)	1
109		100XY-5109			ALLEN SCREW (M10x75)	4

S. NO.	PART NO.	BIN NO. (SG-100XY)	BIN NO. (SG-80MTS)	BIN NO. (SG-9MTS)	DESCRIPTION	QTY
110						
111						
112						
113			80MTS-5113		ALLEN GRUB SCREW (M5x6)	2
114			80MTS-5114		ALLEN HEAD SCREW (M12x16)	2
115			80MTS-5115		ALLEN GRUB SCREW (M6x6)	2
116	055A-639		80MTS-5116		SHAFT EXTENSION	2
117			80MTS-5117		PARALLEL KEY (3/16"x3/16"x1/2")	2
118	055A-640		80MTS-5118		RING NUT	2
119	055A-654-S		80MTS-5119		PARALLEL BAR SCALE	1SET
120	055A-606		80MTS-5120		HEIGHT BLOCK	2
121	055A-668		80MTS-5121		SET SCREW	2
122						
123	055A-646		80MTS-5123		CLAMPING PIN	4
124	055A-648		80MTS-5124		CLAMP PLATE	2
125	055A-684		80MTS-5125		JACK SCREW LARGE	1
126			80MTS-5126		WASHER (M12)	4
127						
128						
129		100XY-5129			BALL BRG (35x55x10)(6907-2RS)	2
130						
131	055A-039	100XY-5131			BRG. SPACER (L.H.)	1
132						
133						
134	055A-802-02	100XY-5134			DRIVE PLATE	1
135	055A-802-03	100XY-5135			MOTOR PLATE	1
136						
137	055A-044	100XY-5137			ECCENTRIC PIN	4
138	055A-045	100XY-5138			ECCENTRIC PIN	4
139	055A-046	100XY-5139			CLAMPING PLATE	2
140		100XY-5140			BALL BRG (608-2RS)(8x22x7)	8
141						
142	055A-078	100XY-5142			KNURLED SCREW	2
143	055A-079	100XY-5143			CLAMPING PLATE	2
144	055A-080	100XY-5144			GUIDE ROD	1
145	055A-140	100XY-5145			RETAINING WASHER	2
146	055A-141	100XY-5146			CLAMP RING	2
147						
148	055A-143	100XY-5148			MTG. FLAT	2
149	055A-147	100XY-5149			CYL PAD (L.H.)	2
150						
151	055A-150	100XY-5151			T-BOLT (L.H.)	2
152						
153						
154	055A-139	100XY-5154			CRADLE COVER	2
155		100XY-5155			AL. BUTTON HD SCREW (M5x10)	8
156		100XY-5156			AL. HD CAP SCREW (M8x20)	2
157						
158		100XY-5158			GEAR BOX (RV-40E)	1
159		100XY-5159			AL. HD. CAP SCREW (M8x65)	16
160		100XY-5160			AL. HD. CAP SCREW (M12x120)	4
161	055A-090	100XY-5161			END STOPPER	4
162		100XY-5162			AL. BUTTON HD. SCREW (M6x10)	8

Pneumatic System

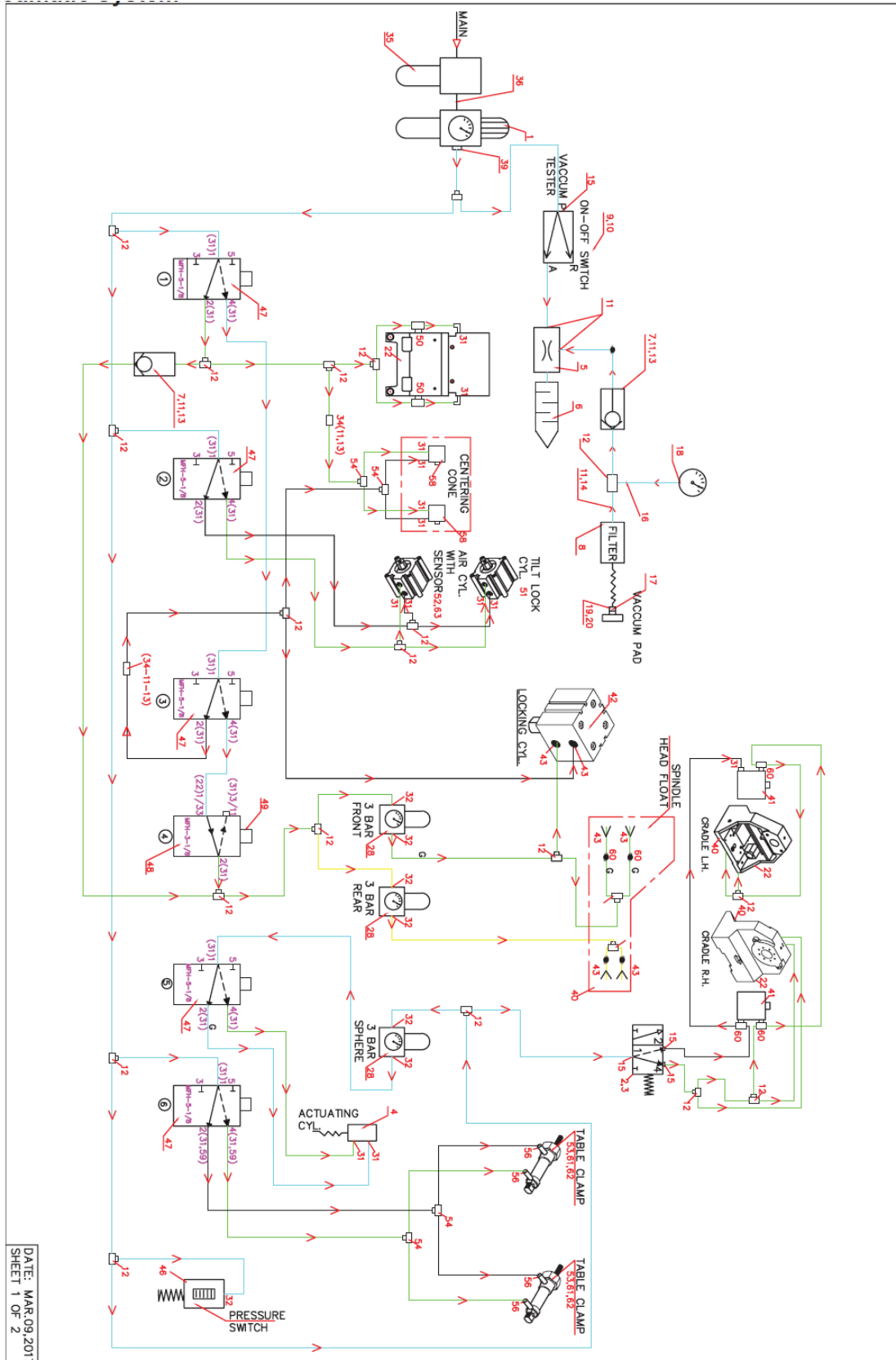

PART LIST (MODEL: SG-100XY)				
MACHINE TYPE: PNEUMATIC PARTS				
S. NO.	PART NO.	DESCRIPTION	QTY	REMARKS
1	162721	FILTER REGULATOR	1	LFR-3/8-D-5M-MIDI
2	11914	BASIC VALVE	1	SV-5-M5B
3	9290	PUSH BUTTON ACTUATOR	1	T-22-G
4	536279	AIR CYLINDER B 008	1	ADN 32-10-1-P-A
5	14015	VACUUM GENERATOR	1	VAD 1/8
6	2307	SILENCER	1	U-1/8
7	3324	NON-RETURN VALVE	2	H-1/8 A/I
8	160239	VACUUM FILTER	1	V-AF-PK-6
9	9301	SELECTOR ACTUATOR	1	N-22-S
10	6817	BASIC VALVE	1	SV-3-M5
11	153002	PUSH-IN/THREADED FITTING	6	QS-1/8-6
12	130974	PUSH-IN T CONNECTOR	17	QST-B-6-20
13	153023	PUSH-IN/THREADED FITTING	4	QSF-1/8-6-B
14	153165	PUSH-IN/THREADED BULKHEAD FITTING	1	QSSF-1/8-8-B
15	153306	PUSH-IN/THREADED FITTING	5	QSM-M5-6
16	153024	PUSH-IN/THREADED FITTING	1	QSF-1/4-6-B
17	153004	PUSH-IN/THREADED FITTING	1	QS-1/8-8
18		VACUUM GAUGE	1	
19	92142110	FEMALE BODY	1	
20	90872110	MALE THREAD (VACUUM PAD)	7	
21				
22	02851100	INT. HEX HEAD PLUG 1/8 NPT	9	
23		TUBE 6x4 MM BLACK	16M	
24		TUBE 6x4 MM BLUE	10M	
25		TUBE 8x55 MM BLUE	2M	
26		TUBE 6x4 MM GREEN	13M	
26-1		TUBE 6x4 MM YELLOW	1M	
27				
28	159625	PRESSURE REGULATOR	3	LR-1/4-D-MINI
29				
30	153077	PUSH-IN/THREADED L FITTING	2	QSL-1/8-6
31	130927	PUSH-IN/THREADED L FITTING	24	QSL-1/8-6
32	153047	PUSH-IN/THREADED L FITTING	7	QSL-1/4-6
33				
34	151165	FLOW CONTROL VALVE	2	GRLA-1/8-B
35	159576	FILTER	1	LF-3/8-D-MIDI
36	15625	DOUBLE NIPPLE	1	E-3/8-3/8-MS
37				
38	153154	PUSH-IN Y CONNECTOR	1	QSY-8-6
39	153006	PUSH-IN/THREADED FITTING	1	QS-3/8-8
40	3568	PLUG	10	1/8
41	536343	AIR CYLINDER	2	ADN-63-15-I-P
42	536393	AIR CYLINDER	1	ADN-125-15-I-P
43	132111	PUSH-IN/THREADED L FITTING	6	SMALL
44				
45				
46	555-21-10	PRESSURE SWITCH	1	PEV-1/4-B
47	6211	SOLENOID VALVE	5	MFH-5-1/4
48	9964	SOLENOID VALVE	1	MFH-3-1/4
49	4540	SOLENOID COIL	6	MSFW-230 AC
50	130939	PUSH-IN/THREADED T FITTING	2	QST-1/8-6
51	SMC	AIR CYLINDER	1	ICQ2A 50-15 DZ
52	SMC	AIR CYLINDER	1	CDQ 2A-50-15-DZ
53	19210	TABLE CLAMP CYLINDER	2	DSNU-20-50-P-A
54	130973	PUSH-IN T CONNECTOR	4	QST-B-4
55				
56	130900	PUSH-IN/THREADED L FITTING	4	QSML-B-M5-4
57				
58	SMC	AIR CYLINDER	2	ICQ 2B32-15-D
59	153041	PUSH-IN CONNECTOR	2	QS-6H-4
60	153357	PUSH-IN T CONNECTOR	5	QSMT-1/8-6
61	36198(FESTO)	TABLE LOCK WIRE (PROX SENSOR)	2	SMED-4U-K-LED-24
62	19276(FESTO)	TABLE LOCK CLAMP (MOUNTING KIT)	2	SMBR-20
63	SMC	SENSOR	1	D-M9-PV-LUG

Pneumatic Air Hose Diagram

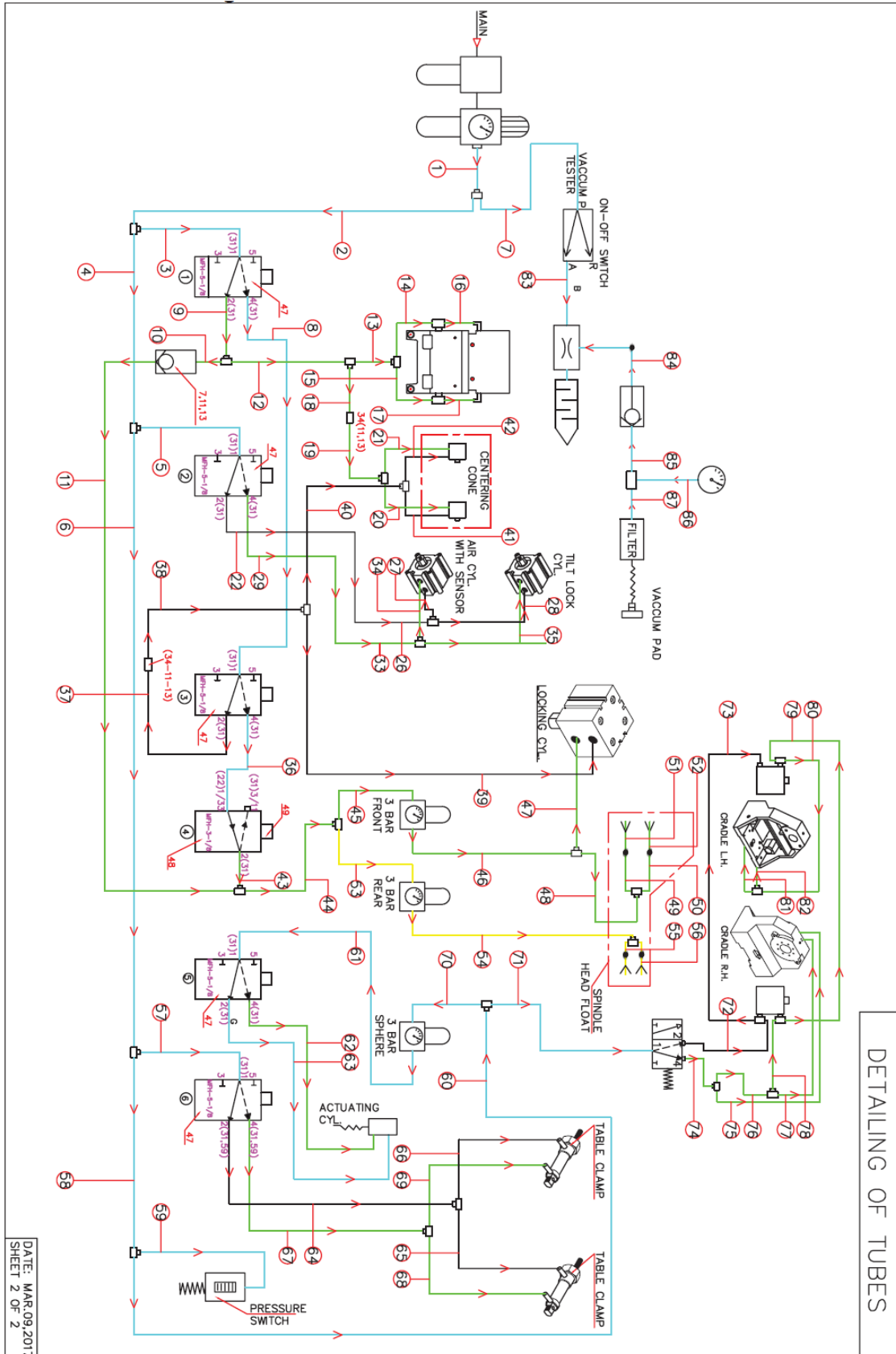

TUBE NO.	TUBE COLOR	TUBE DESCRIPTION	TUBE NO.	TUBE COLOR	TUBE DESCRIPTION
1	BLUE	M8x48"	51	GREEN	M6x8"
2	BLUE	M6x2"	52	GREEN	M6x8"
3	BLUE	M6x3"	53	YELLOW	M6x4"
4	BLUE	M6x4.5"	54	YELLOW	M6x200"
5	BLUE	M6x35"	55	YELLOW	M6x7"
6	BLUE	M6x24"	56	YELLOW	M6x7"
7	BLUE	M6x100"	57	BLUE	M6x2.5"
8	BLUE	M6x10"	58	BLUE	M6x18"
9	GREEN	M6x6"	59	BLUE	M6x4"
10	GREEN	M6x2"	60	BLUE	M6x50"
11	GREEN	M6x9"	61	BLUE	M6x100"
12	GREEN	M6x185"	62	GREEN	M6x237"
13	GREEN	M6x4"	63	BLUE	M6x237"
14	GREEN	M6x24"	64	BLACK	M4x2"
15	GREEN	M6x2"	65	BLACK	M4x90"
16	GREEN	M6x12"	66	BLACK	M4x110"
17	GREEN	M6x12"	67	GREEN	M4x2"
18	GREEN	M6x3"	68	GREEN	M4x90"
19	GREEN	M4x4"	69	GREEN	M4x110"
20	GREEN	M4x12"	70	BLUE	M6x40"
21	GREEN	M4x50"	71	BLUE	M6x102"
22	BLACK	M6x50"	72	BLACK	M6x15"
23			73	BLACK	M6x300"
24			74	GREEN	M6x2"
25			75	GREEN	M6x2"
26	BLACK	M6x125"	76	GREEN	M6x7"
27	BLACK	M6x10"	77	GREEN	M6x7"
28	BLACK	M6x10"	78	GREEN	M6x12"
29	GREEN	M6x3"	79	GREEN	M6x300"
30			80	GREEN	M6x10"
31			81	GREEN	M6x6"
32			82	GREEN	M6x5"
33	GREEN	M6x125"	83	BLUE	M6x4"
34	GREEN	M6x10"	84	BLUE	M6x1.5"
35	GREEN	M6x10"	85	BLUE	M6x1.5"
36	BLUE	M6x7.5"	86	BLUE	M6x3"
37	BLACK	M6x2"	87	BLUE	M6x4"
38	BLACK	M6x175"	88		
39	BLACK	M6x55"	89		
40	BLACK	M4x8"			
41	BLACK	M4x50"			
42	BLACK	M4x50"			
43	GREEN	M6x2"			
44	GREEN	M6x100"			
45	GREEN	M6x10"			
46	GREEN	M6x175"			
47	GREEN	M6x16"			
48	GREEN	M6x25"			
49	GREEN	M6x10"			
50	GREEN	M6x10"			

SG100XY-GE MACHINE ASSEMBLY PARTS Bed, Table, and Riser Assembly Parts

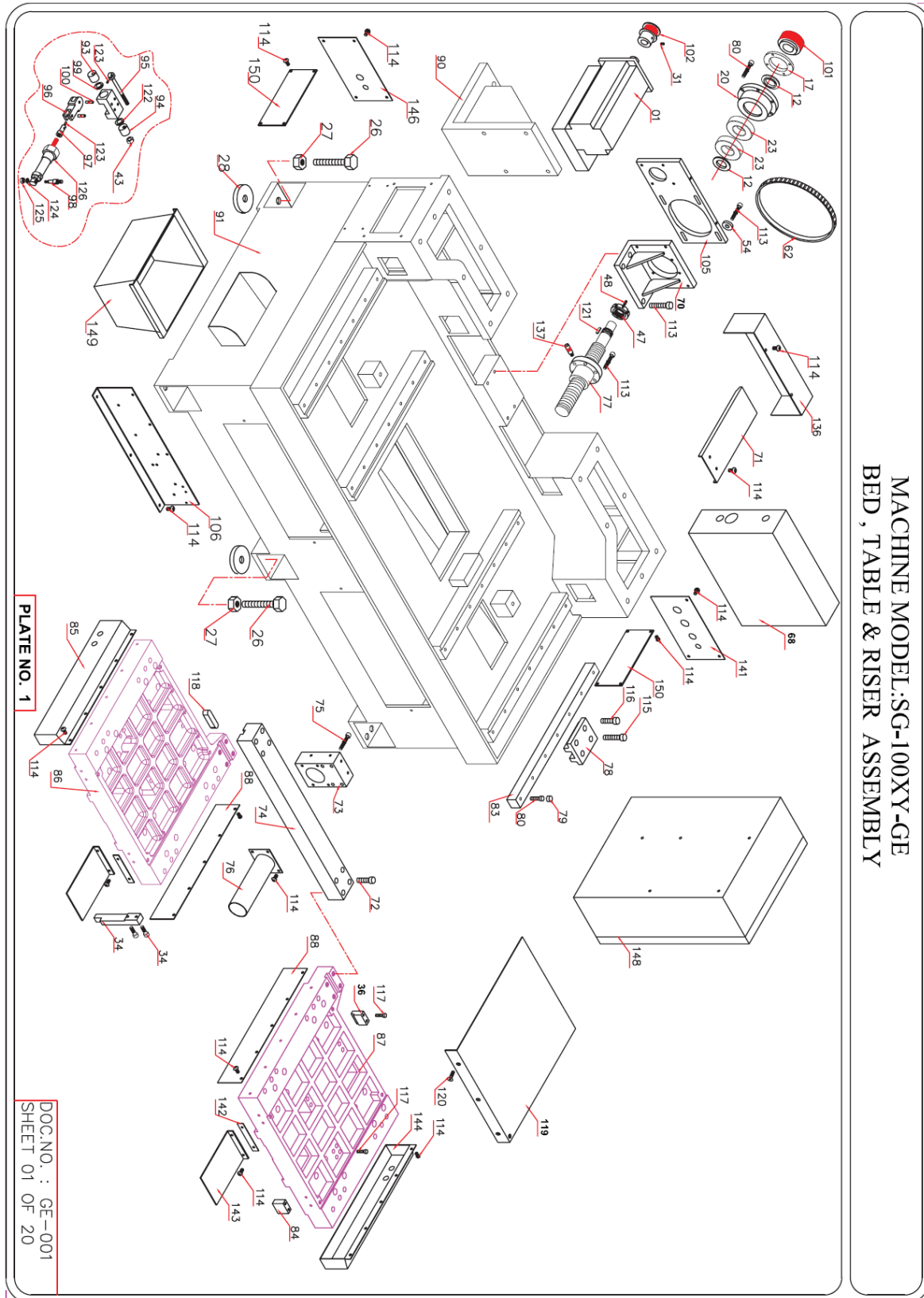

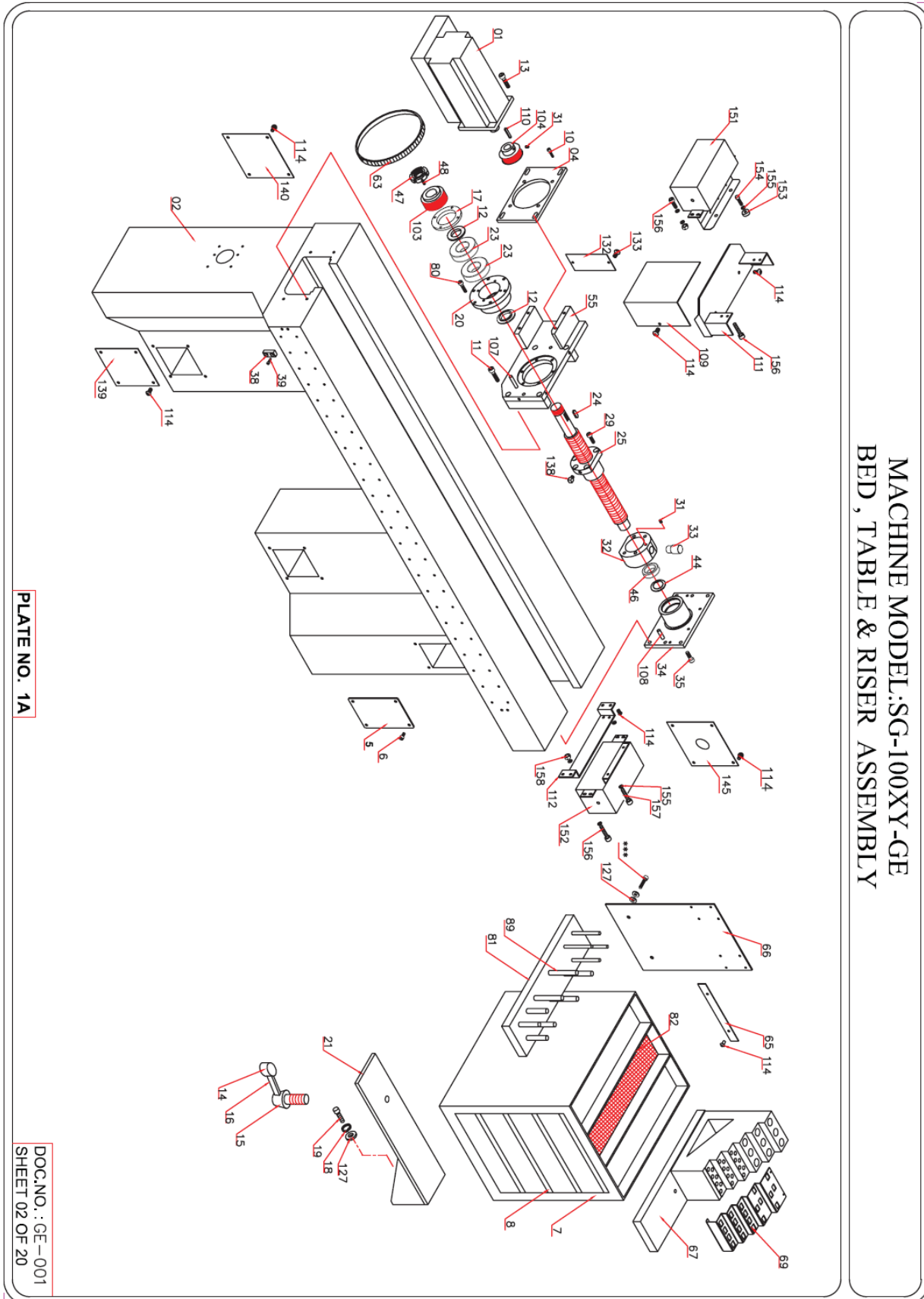

S. NO.	PART NO.	BIN NO. (SG-100XY)	BIN NO. (SG-80MTS)	BIN NO. (SG-9MTS)	DESCRIPTION	QTY
1		100XY-1			A.C. SERVO MOTOR BSM-80-C-375-AB2	2
2	055A-023	100XY-1			RISER	1
3						
4	055A-071	100XY-1			MOTOR FLANGE (X)	1
5	GE-54				NAME PLATE	1
6			80MTS-106		BUTTON HEAD SCREW (M6x12)	4
7	055A-760		80MTS-107		TOOL CABINET	1
8			80MTS-108		TOOL TRAY	4
9						
10		100XY-1			AL. HEAD SCREW (M6x20)	4
11		100XY-1			AL. HEAD SCREW (M8x50)	4
12	055A-055	100XY-1			BEARING SPACER	4
13		100XY-1			AL. HEAD SCREW (M6x16)	4
14	430-802			9-MTS-114	KNOB (M8x25MM O.D.)	1
15	430-817-1			9-MTS-115	CLAMP PIN	1
16	430-823			9-MTS-116	CLAMP LEVER	1
17	055A-054	100XY-1			BRG. RETAINER	2
18	VGS-804			9-MTS-118	SPRING WASHER (M8)	1
19	VGS-803			9-MTS-119	AL. HEAD SCREW (M8x30)	1
20	055A-053	100XY-1			BEARING HOUSING	2
21	440-113			10XY-113	MTG. BKT.	1
22						
23		100XY-1			ANG. CONTACT BRG. (30x62x16)	4
24		100XY-1			KEY (8x7x25)	1
25	055A-067	100XY-1			LONG BALL SCREW	1
26	430-818			9-MTS-126	LEVELING BOLT (M16x75)	8
27	430-818-A			9-MTS-127	HEX NUT (M16)	8
28	430-819			9-MTS-128	PAD	8
29		100XY-1			ALLEN HEAD SCREW (M8x20)	4
30		100XY-1			ALLEN HEAD GRUB SCREW (M8x20)	2
31		100XY-1			ALLEN HEAD GRUB SCREW (M6x10)	3
32	055A-069	100XY-1			BALL NUT (X)	1
33	055A-070	100XY-1			BALL NUT PIN	1
34	055A-068	100XY-1			BEARING HOUSING (X)	1
35		100XY-1			ALLEN HEAD SCREW (M8x25)	4
36	GE-35				STOPPER	2
37						
38	055A-077	100XY-1			RISER STOPPER	2
39		100XY-1			ALLEN HEAD SCREW (M6x12)	4
40						
41						
42						
43						
44		100XY-1			INTERNAL CIRCLIP (55MM)	1
45						
46		100XY-1			BALL BRG (6006-2RS)(30x45x13)	1
47	055A-406		80MTS-402		SHAFT NUT	2
48			80MTS-403		ALLEN GRUB SCREW (M5x8)	2
49						
50						
51						
52						
53						

S. NO.	PART NO.	BIN NO. (SG-100XY)	BIN NO. (SG-80MTS)	BIN NO. (SG-9MTS)	DESCRIPTION	QTY
54		100XY-154			PLAIN WASHER (M8)	4
55	055A-064	100XY-155			MOTOR BKT (X)	1
56						
57						
58						
59						
60						
61						
62		100XY-162			BELT L-225	1
63		100XY-163			BELT L-210	1
64		100XY-164			ALLEN HEAD SCREW (M6x25)	12
65	430-839-4			9-MTS-165	NAME PLATE	2
66	055A-757		80MTS-166		SUPPORT PLATE	1
67	055A-756		80MTS-167		STAND	1
68	GE-50				AIR FITTING BOX	1
69	055A-758		80MTS-169		PILOT STAND	1
70	GE-34				CROSS BRACKET	1
71	055A-087	100XY-171			REAR SCREW COVER (Y)	1
72		100XY-172			ALLEN HEAD SCREW (M12x60)	8
73	055A-057	100XY-173			NUT BRACKET (Y)	1
74	055A-050	100XY-174			CROSS MEMBER	1
75		100XY-175			ALLEN HEAD SCREW (M8x50)	4
76	055A-086	100XY-176			FRONT SCREW COVER	1
77	055A-058	100XY-177			CROSS BALL SCREW	1
78		100XY-178			CARRIAGE BLOCK & WIPER	8
79		100XY-179			PLUG	28
80		100XY-180			ALLEN HEAD SCREW (M8x30)	28
81	055A-759		80MTS-181		TOOL BOARD (L.H.) WITH PINS	1
82	055A-755		80MTS-182		RUBBER SHEET	1
83		100XY-183			RAIL SLIDE	4
84	055A-035	100XY-184			STOPPER	2
85	055A-082	100XY-185			TABLE SIDE COVER (L.H.)	1
86	055A-025	100XY-186			L.H. CROSS TABLE	1
87	055A-024	100XY-187			R.H. CROSS TABLE	1
88	055A-083	100XY-188			TABLE SIDE COVER	2
89	055A-766		80MTS-189		PIN	4
90	055A-048	100XY-190			CABINET SUPPORT	3
91	055A-047	100XY-191			CABINET	1
92	055A-026	100XY-192			CLAMPING BRACKET	2
93	055A-027	100XY-193			CLAMPING PAD	2
94	055A-028	100XY-194			CLAMPING PAD	2
95	055A-029	100XY-195			CLAMPING BOLT	2
96	055A-030	100XY-196			CLAMPING LEVER	2
97	055A-031	100XY-197			PIN JOINT	2
98	055A-032	100XY-198			CYL. PIVOT	2
99	055A-033	100XY-199			SPACER	2
100	055A-034	100XY-1100			CYL. PIN	4
101	055A-145	100XY-1101			SCREW PULLEY (Y)	1
102	055A-146	100XY-1102			MOTOR PULLEY (Y)	1
103	055A-065	100XY-1103			SCREW PULLEY (X)	1
104	055A-066	100XY-1104			MOTOR PULLEY (X)	1
105	055A-052	100XY-1105			MOTOR SUPPORT	1
106	055A-144	100XY-1106			BRACKET	2
107		100XY-1107			DOWEL PIN (M8x30)	2

S. NO.	PART NO.	BIN NO. (SG-100XY)	BIN NO. (SG-80MTS)	BIN NO. (SG-9MTS)	DESCRIPTION	QTY
108		100XY-1108			DOWEL PIN (M8x40)	2
109	055A-088	100XY-1109			BRACKET COVER (X)	1
110		100XY-1110			KEY (X)	1
111	055A-091	100XY-1111			LEFT RISER STOPPER	1
112	055A-092	100XY-1112			RIGHT RISER STOPPER	1
113		100XY-1113			ALLEN HEAD SCREW (M8x25)	17
114		100XY-1114			BUTTON HEAD SCREW (M6x10)	81
115		100XY-1115			ALLEN HEAD SCREW (M10x65)	16
116		100XY-1116			ALLEN HEAD SCREW (M10x35)	16
117		100XY-1117			ALLEN HEAD SCREW (M6x40)	16
118		100XY-1118			PARALLEL KEY (0.625"x0.625"x2.5")	2
119	GE-53	100XY-1119			TABLE COVER	2
120					BUTTON HEAD SCREW (M6x10)	6
121		100XY-1121			KEY (8x7x22)	1
122		100XY-1122			O-RING (M10x2)	4
123		100XY-1123			ALLEN HEAD GRUB SCREW (M4x6)	2
124		100XY-1124			WASHER (M6)	2
125		100XY-1125			NUT (M6)	4
126	DSNU 20-50-P-A	100XY-1126			PNEUMATIC CYL. (19210-FESTO) WITH SENSOR & MTG. KIT	2
127		100XY-1127			WASHER (M8)	5
128						
129						
130						
131						
132	055A-155	100XY-1132			BELT COVER	1
133		100XY-1133			BUTTON HEAD SCREW (M5x10)	2
134	055A-157	100XY-1134			STOPPER FLAT	1
135		100XY-1135			ALLEN HEAD SCREW (M6x--)	2
136	055A-156	100XY-1136			BELT COVER	1
137	055A-162	100XY-1137			OIL FITTING FOR Y-AXIS SCREW	1
138	055A-163	100XY-1138			OIL FITTING FOR X-AXIS SCREW	1
139	055A-084	100XY-1139			COVER (FRONT SIDE)	2
140	055A-085	100XY-1140			COVER (BACK SIDE)(L.H.)	1
141	055A-095	100XY-1141			CABINET COVER (BACK SIDE)(R.H.)	1
142	055A-165	100XY-1142			CLAMP STRIP	4
143	055A-166	100XY-1143			FLAP GUARD	4
144	055A-167	100XY-1144			TABLE SIDE COVER (R.H.)	1
145	055A-168	100XY-1145			COVER (BACK SIDE)(R.H.)	1
146	055A-169	100XY-1146			CABINET COVER (BACK SIDE)(L.H.)	1
147						
148	055A-891	100XY-1148			PANEL BOX	1
149	055A-892	100XY-1149			CHIP TRAY	1
150	055A-893	100XY-1150			CABINET SIDE COVER	2
151	440-284-L			10XY-1160	COVER	1
152	440-284-R			10XY-1108	COVER	1
153	440-285-I			10XY-1109	SPACER	2
154				10XY-1-110	ALLEN HEAD SCREW (M5x25)	2
155		100XY-1155			M.S. WASHER (M5)	20
156				10XY-1-111	ALLEN HEAD SCREW (M5x12)	8
157		100XY-1157			ALLEN HEAD SCREW (M5x16)	2
158		100XY-1158			HEX NUT (M5)	8
159						
160						
161						
162						

Base Assembly Parts

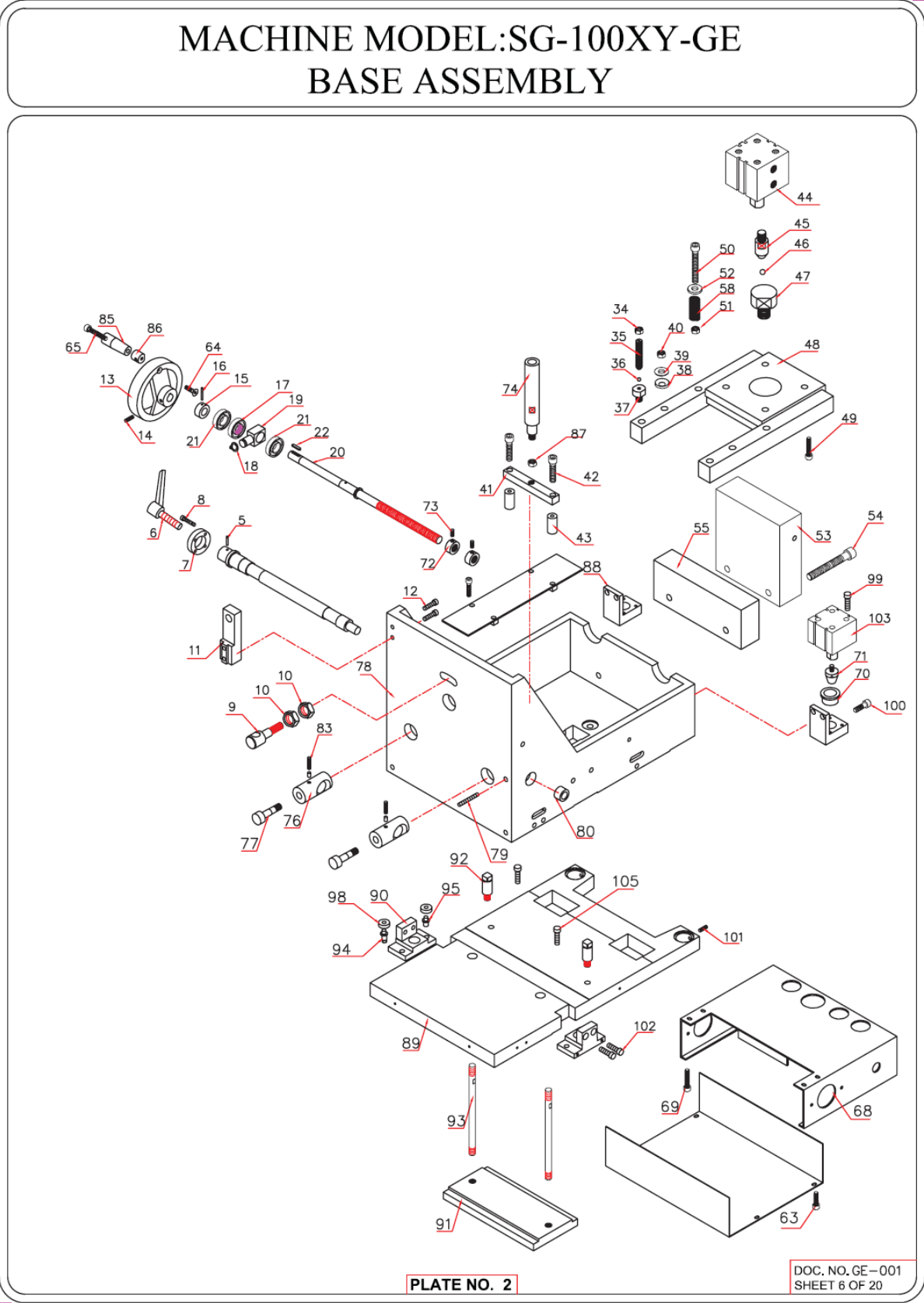

PLATE NO. 2

DOC. NO. GE-001
SHEET 6 OF 20

S. NO.	PART NO.	BIN NO. (SG-100XY)	BIN NO. (SG-80MTS)	BIN NO. (SG-80A)	DESCRIPTION	QTY
1						
2						
3						
4						
5			80MTS-205		CYLINDRICAL PIN (DIA 1/8" x 1 1/8" LG)	1
6			80MTS-206		ADJUSTABLE HANDLE	1
7	055A-321		80MTS-207		SPACER HOUSING	1
8			80MTS-208		ALLEN SCREW (M6x16)	4
9	055A-264		80MTS-209		LOCATING BOLT	1
10	055A-320		80MTS-210		NUT	2
11	055A-327		80MTS-211		SCREW BLOCK	1
12			80MTS-212		ALLEN SCREW (M8x40)	2
13	055A-311		80MTS-213		HAND WHEEL	1
14			80MTS-214		ALLEN GRUB SCREW (M6x10)	1
15	055A-309		80MTS-215		SPACER	1
16			80MTS-216		SPRING DOWEL (DIA 1/8" x 1 1/8" LG)	1
17	HK1612D		80MTS-217		NEEDLE ROLLER BEARING (NTN-181408)	1
18			80MTS-218		EXT. CIRCLIP (A16)	1
19	055A-304		80MTS-219		GUIDE PIN	1
20	055A-310		80MTS-220		INCLINATION ROD	1
21			80MTS-221		NEEDLE THRUST BEARING	2
22			80MTS-222		PARALLEL KEY (3/16"x3/16"x7/8")	1
23						
24						
25						
26						
27						
28						
29						
30						
31						
32						
33						
34			80MTS-234		HEX NUT (M12)	2
35	055A-308		80MTS-235		SET SCREW	2
36			80MTS-236		STEEL BALL (DIA 1/4")	2
37	055A-301		80MTS-237		PIVOT	2
38	055A-323		80MTS-238		SPHERICAL WASHER	6
39	055A-324		80MTS-239		SPHERICAL WASHER	6
40			80MTS-240		NYLOCK HEX NUT (M12)	2
41	055A-316		80MTS-241		SWIVEL BRACKET	1
42			80MTS-242		ALLEN SCREW (M6x55)	2
43	055A-315		80MTS-243		SPACER	2
44	#125-15-I-PA		80MTS-244		PNEUMATIC CYLINDER (536393)	1
45	055A-306		80MTS-245		PIVOT PIN	1
46			80MTS-246		STEEL BALL (DIA 3/8")	1
47	055A-303		80MTS-247		BALL SUPPORT	1
48	055A-322		80MTS-248		CLAMPING BRACKET	1
49			80MTS-249		ALLEN SCREW (M12x30)	4
50			80MTS-250		AL. HEAD SCREW (M8x80)	2
51			80MTS-251		HEX NUT (M8)	2
52			80MTS-252		WASHER (M8)	2
53	055A-049	100XY-253			WEIGHT	1
54				80A-254	ALLEN SCREW (M12x110)	2

S. NO.	PART NO.	BIN NO. (SG-100XY)	BIN NO. (SG-80MTS)	BIN NO. (SG-9MTS)	DESCRIPTION	QTY
55	055A-158	100XY-255			SPACING PLATE	1
56						
57						
58	282580		80MTS-258		COMP. SPRING	2
59						
60						
61						
62						
63				80A-2152	AL. HEAD SCREW (M6x10)	2
64				80A-2155	CSK. HEAD SCREW (M6x15)	1
65				80A-2156	AL. HEAD SCREW (M8x20)	1
66						
67						
68	055A-710	100XY-268			CABLE TRAY WITH COVER	1EA
69		100XY-269			ALLEN HEAD SCREW (M6x12)	4
70	440-240				TAPER BUSH	2
71	440-281				CEN. CONE	2
72	055A-342		80MTS-272		STOP COLLAR	2
73			80MTS-273		ALLEN SET SCREW (M6x12)	2
74	055A-341		80MTS-274		TIE ROD SUPPORT	1
75	055A-334		80MTS-275		ECCENTRIC SHAFT	1
76	055A-336		80MTS-276		CLAMPING BLOCK	2
77	055A-339		80MTS-277		CLAMPING BOLT	2
78	055A-015	100XY-278			BASE	1
79			80MTS-279		GRUB SCREW (M6x16)	2
80	055A-345		80MTS-280		ECCENTRIC BUSH	1
81	055A-015-1	100XY-281			COVER PLATE	1
82						
83			80MTS-283		GRUB SCREW (M6x8)	2
84						
85	055A-888		80MTS-285		KNOB	1
86	055A-889		80MTS-286		PLUG (LEVER)	1
87			80MTS-287		HEX NUT (M12)	1
88	055A-022	100XY-288			CYL. BKT.	2
89	055A-059	100XY-289			SUPPORT PLATE (X)	1
90	055A-060	100XY-290			BEARING PLATE	2
91	055A-061	100XY-291			CLAMP PLATE	1
92	055A-062	100XY-292			THREADED PIN	2
93	055A-063	100XY-293			CLAMPING STUD	2
94	055A-044	100XY-294			ECCENTRIC PIN	2
95	055A-045	100XY-295			ECCENTRIC PIN	2
96		100XY-296			ALLEN HEAD SCREW (M5x12)	4
97						
98		100XY-298			BALL BRG. (608-2RS)(8x22x7)	4
99		100XY-2150			ALLEN HEAD SCREW (M5x40)	4
100		100XY-2151			ALLEN HEAD SCREW (M5x50)	2
101		100XY-2153			ALLEN HEAD GRUB SCREW (M6x10)	2
102		100XY-2154			ALLEN HEAD SCREW (M8x16)	4
103		100XY-2157			AIR CYL. (32x15)	2
104						
105		100XY-2159			ALLEN HEAD SCREW (M6x60)	2
106						
107						

Spindle Assembly

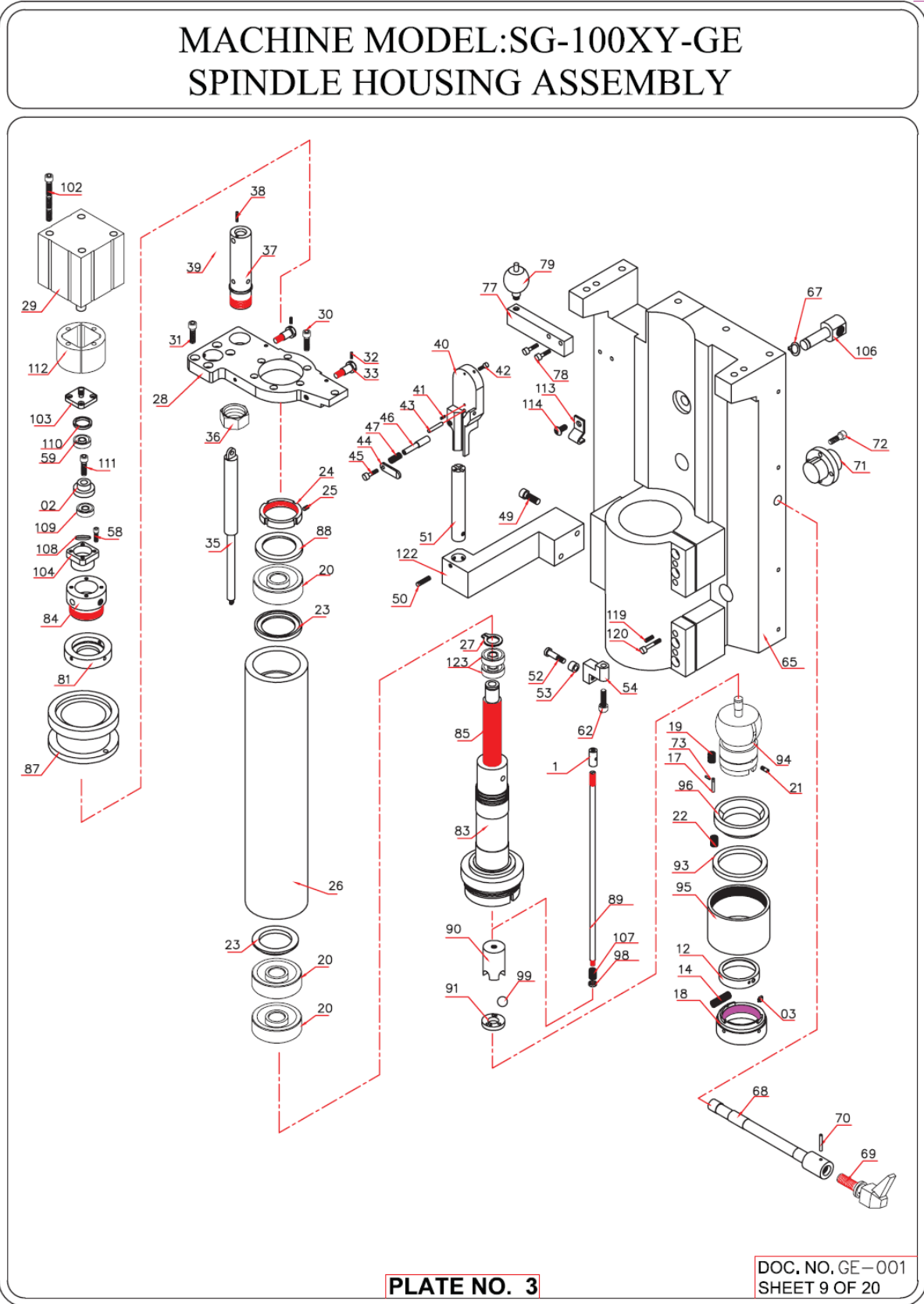

S. NO.	PART NO.	BIN NO. (SG-100XY & MTS)	BIN NO. (SG-80MTS)	BIN NO. (SG-80A)	BIN NO. (SG-9MTS)	DESCRIPTION	QTY
1	NCL-72-1				9MTS-301-D	ROTATING PIN	1
2	NCL-72-2				9MTS-301-F	BEARING HOLDER	1
3	KS-08-02				9MTS-305	PAD	1
4							
5							
6							
7							
8							
9							
10							
11							
12	KS-09-06		80MTS-312			COVER	1
13							
14	KS-09-03		80MTS-314			COMP. SPRING	2
15							
16							
17	KS-08-05				9MTS-318	PIN	1
18	KS-09-07		80MTS-318			NUT	1
19	KS-08-01				9MTS-319	COMP. SPRING	1
20			80MTS-320			ANG. CONT. BALL BRG (50x72x12)	3
21	KS-08-01				9MTS-320	STOP PIN	1
22	5203-3				9MTS-322	SPRING	3
23	055A-181	100MTS-323				BRG. SPACER	2
24	055A-106		80MTS-324			SPINDLE NUT	1
25			80MTS-325			ALLEN GRUB SCREW (M5x8)	2
26	055A-170	100XY-326				QUILL	1
27					9MTS-327	EXT. CIRCLIP (DIA 20MM)	1
28	055A-190			80A-328		STOP PLATE	1
29	53679-B008				9MTS-329	ACTUATING CYL (AND-32-10-I-P)	1
30			80MTS-330			ALLEN SCREW (M6x25)	6
31				80A-331		ALLEN SCREW (M8x20)	4
32			80MTS-332			ALLEN GRUB SCREW (M5x6)	2
33	055A-121		80MTS-333			ADJUSTING SCREW	2
34							
35			80MTS-335			COMP. GAS SPRING	1
36	055A-104		80MTS-336			NUT	1
37	055A-111		80MTS-337			GAS SPRING SUPPORT	1
38			80MTS-338			ALLEN GRUB SCREW (M4x6)	1
39	055A-113		80MTS-339			CYL. PIN	1
40	055A-236		80MTS-340			LEVEL BLOCK	1
41			80MTS-341			ALLEN GRUB SCREW (M6x16)	1
42			80MTS-342			ALLEN SCREW (6-32 x 3/8" LG)	2
43			80MTS-343			CYL. PIN (DIA 3/16x1 1/8"LG)	1
44	055A-237		80MTS-344			CLAMP	1
45			80MTS-345			ALLEN SCREW (M5x12)	1
46	055A-238		80MTS-346			CLAMP PIN	1
47	055A-240		80MTS-347			SPRING	1
48							
49			80MTS-349			ALLEN SCREW (M8x50)	2
50			80MTS-350			ALLEN GRUB SCREW (M6x12)	3
51	055A-239		80MTS-351			CLAMP	1
52	055A-247		80MTS-352			GAS SPRING SCREW	1
53	055A-248		80MTS-353			GAS SPRING SPACER	1
54	055A-295			80A-354		GAS SPRING HOLDER	1

S. NO.	PART NO.	BIN NO. (SG-100XY & MTS)	BIN NO. (SG-80MTS)	BIN NO. (SG-80A)	BIN NO. (SG-9MTS)	DESCRIPTION	QTY
55							
56							
57							
58					9MTS-358	ALLEN CAP SCREW (M5x12)	4
59	6001-2RS-1				9MTS-359	BALL BRG. (12x28x8)	1
60							
61							
62				80A-362		ALLEN CAP SCREW (M8x35)	1
63							
64							
65	055A-297			80A-365		SPINDLE HOUSING	1
66							
67			80MTS-367			EXT. CIRCLIP (A16)	1
68	055A-268		80MTS-368			ECCENTRIC CLAMP	1
69			80MTS-369			ADJUSTABLE HANDLE	1
70			80MTS-370			CYL. PIN (DIA 1/8" x 1 1/8" LG)	1
71	055A-219		80MTS-371			PIVOT PIN	1
72			80MTS-372			ALLEN SCREW (M6x12)	4
73			80MTS-373			PIN (DIA 0.093"x0.350"LG)	1
74							
75							
76							
77	055A-337			80A-377		LUB FEEDER	1
78				80A-378		ALLEN HEAD SCREW (M6x20)	2
79				80A-379		OILER	1
80							
81	NCL-70-2				9MTS-381	CLAMP NUT	1
82							
83	055A-176-1	100MTS-383				SPINDLE	1
84	NCL-70-1				9MTS-384	BEARING HOUSING	1
85	055A-176-2	100MTS-385				SPLINE SHAFT	1
86							
87	055A-187	100MTS-387				TOP STOPPER	1
88	055A-182	100MTS-388				BRG. SPACER	1
89	055A-138	100MTS-389				THREAD ROD	1
90	055A-177	100MTS-390				BALL CAGE	1
91	055A-178	100MTS-391				BALL SPACER	1
92							
93	055A-175	100MTS-393				SPRING SPACER	1
94	055A-172	100MTS-394				DRIVE ADAPTER	1
95	055A-173	100MTS-395				SHPERE CAP	1
96	055A-174	100MTS-396				LOWER CONE	1
97	055A-154	100XY-397				SPACING RING	1
98	055A-149	100MTS-398				SPACER	1
99		100MTS-399				STEEL BAL (DIA 0.500")	3
100							
101							
102					9MTS-3102	ALLEN HEAD SCREW (M5x95)	4
103	NC-141				9MTS-3103	SUPPORT PLATE	1
104	NC-140				9MTS-3104	BEARING HOUSING	1
105							

Transmission Assembly Parts

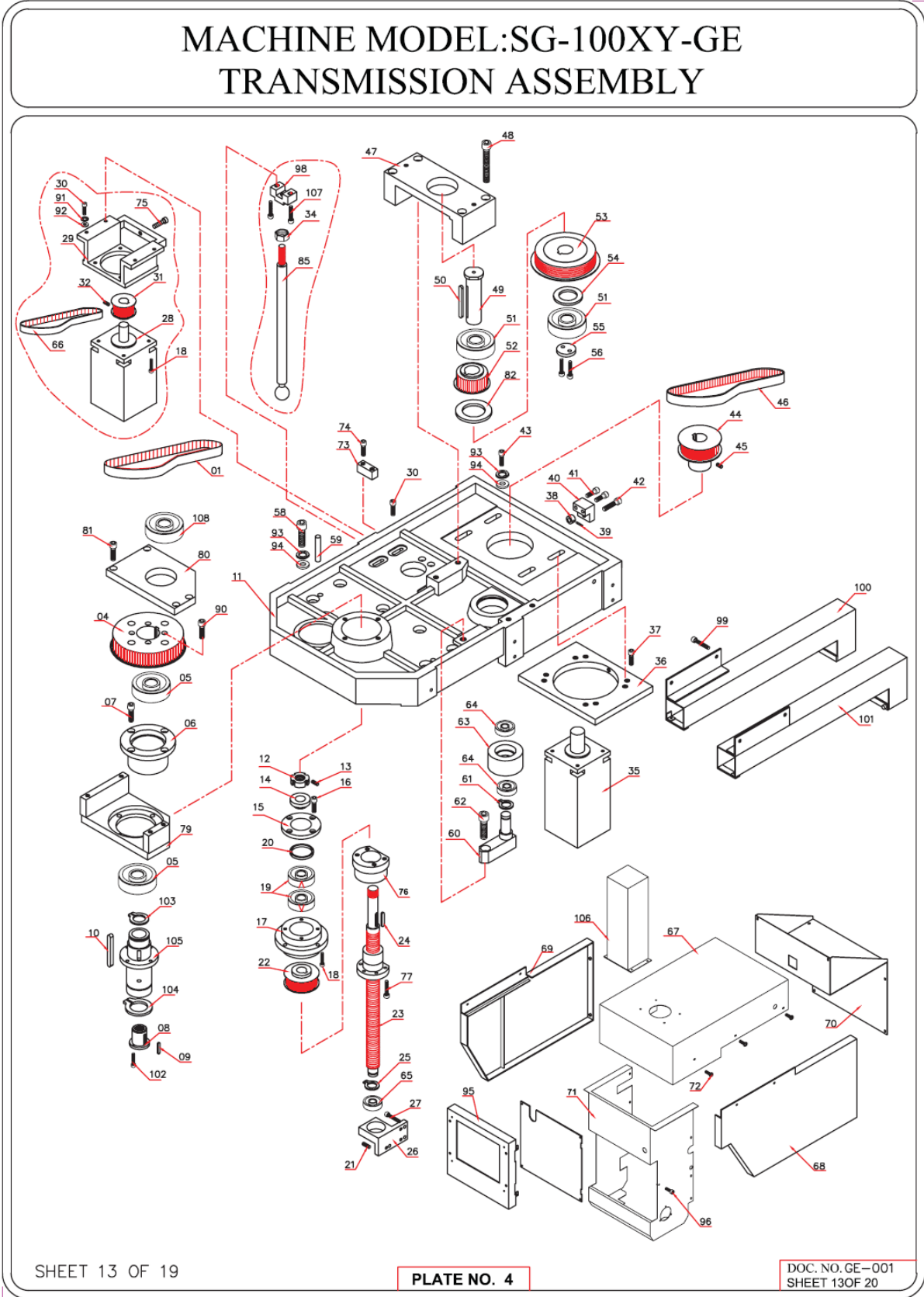

SHEET 13 OF 19

PLATE NO. 4

DOC. NO. GE-001
SHEET 13 OF 20

S. NO.	PART NO.	BIN NO. (SG-100XY & MTS)	BIN NO. (SG-80MTS)	BIN NO. (SG-80A)	DESCRIPTION	QTY
1				80A-401	SPINDLE POLY CHAIN BELT (896-21)	1
2						
3						
4	055A-184	100MTS-404			SPINDLE PULLEY	1
5	6910	100MTS-405			BALL BEARING (50x72x12-2RS)	2
6	055A-185	100MTS-406			BEARING HOUSING	1
7			80MTS-407		ALLEN SCREW (M8x25)	4
8	055A-186	100MTS-408			SPLINE BUSH	1
9			80MTS-306		PARALLEL KEY (1/4"x1/4"x1 1/2")	1
10			80MTS-410		PARALLEL KEY (5/16"x5/16"x1 1/4")	1
11	055A-255			80A-411	TOP PLATE	1
12	055A-422			80A-412	RING NUT	1
13			80MTS-413		ALLEN HEAD GRUB SCREW (M6x12)	1
14	055A-430			80A-414	BEARING SPACER	1
15	055A-442			80A-415	BEARING COVER	1
16				80A-416	ALLEN HD GRUB SCREW (M6x12)	4
17	055A-441			80A-417	BEARING HOUSING	1
18				80A-418	ALLEN SCREW (M6x16)	8
19				80A-419	ANG. CONTACT BALL BRG. (7204)	2
20	055A-443			80A-420	BEARING SPACER	1
21				80A-421	ALLEN GRUB SCREW (M6x10)	4
22	055A-427			80A-422	PULLEY	1
23	055A-480			80A-423	BALL SCREW	1
24				80A-424	PARALLEL KEY (1/4"x1/4"x1 5/16")	1
25				80A-425	EXT. CIRCLIP (A12)	1
26	055A-479			80A-426	BEARING HOUSING	1
27				80A-427	ALLEN SCREW (M6x16)	4
28				80A-428	Z-AXIS MOTOR	1
29	055A-405			80A-429	MOTOR SUPPORT	1
30				80A-430	ALLEN SCREW (M6x25)	8
31	055A-409			80A-431	MOTOR PULLEY	1
32				80A-432	ALLEN GRUB SCREW (M5x8)	1
33						
34			80MTS-434		HEX NUT (M12)	1
35				80A-435	SPINDLE MOTOR	1
36	055A-407			80A-436	MOTOR PLATE	1
37			80MTS-437		ALLEN SCREW (M10x25)	4
38	055A-254		80MTS-438		SPACER	1
39			80MTS-439		CYLINDRICAL PIN (DIA 1/8"X5/8" LG)	1
40	055A-253		80MTS-440		ADJUSTING BLOCK	1
41			80MTS-441		ALLEN SCREW (M6x30)	2
42			80MTS-442		ALLEN SCREW (M8x50)	2
43			80MTS-443		ALLEN SCREW (M10x30)	4
44	055A-438			80A-444	MOTOR PULLEY	1
45			80MTS-445		ALLEN GRUB SCREW (M6x10)	1
46			80MTS-446		MOTOR POLY CHAIN BELT (N720-21)	1
47	055A-256		80MTS-447		BEARING SUPPORT	1
48			80MTS-448		ALLEN SCREW (M10x75)	4
49	055A-440		80MTS-449		INT. SHAFT	1
50			80MTS-450		PARALLEL KEY (5/16"x5/16"x3")	1
51			80MTS-451		BALL BEARING (6206)	2
52	055A-448		80MTS-452		UPPER INT. PULLEY	1
53	055A-439		80MTS-453		LOWER INT. PULLEY	1
54			80MTS-454		INT. CIRCLIP (B62)	1

S. NO.	PART NO.	BIN NO. (SG-100XY & MTS)	BIN NO. (SG-80MTS)	BIN NO. (SG-80A)	DESCRIPTION	QTY
55	055A-435		80MTS-455		BEARING SPACER	1
56			80MTS-456		ALLEN SCREW (M6x20)	2
57						
58			80MTS-458		ALLEN SCREW (M10x35)	6
59			80MTS-459		CYL. PIN	2
60	055A-478		80MTS-460		IDLER SUPPORT	1
61			80MTS-461		EXT. CIRCLIP (A20)	1
62			80MTS-462		ALLEN SCREW (M12x35)	1
63	055A-436		80MTS-463		IDLER PULLEY	1
64			80MTS-464		BALL BEARING (6004 LLU/2AS)	2
65				80A-465	BALL BEARING (6094-2RS)(20x37x9)	1
66				80A-466	TIMING BELT (L-275)	1
67	055A-097	100XY-467			TOP COVER	1
68	055A-159	100XY-468			RIGHT COVER	1
69	055A-160	100XY-469			LEFT COVER	1
70	055A-161	100XY-470			BACK COVER	1
71	GE-51				FRONT COVER	1
72			80MTS-472		ALLEN BUTTON SCREW (M5x6)	26
73	055A-283			80A-473	BLOCK	1
74				80A-474	ALLEN HEAD SCREW (M8x25)	2
75				80A-475	ALLEN HEAD SCREW (M8x35)	1
76	GE-52				BALL SCREW BRACKET	1
77				80A-477	ALLEN HEAD SCREW (M5x16)	5
78						
79	055A-474		80MTS-479		BEARING SUPPORT	1
80	055A-475		80MTS-480		BEARING COVER	1
81			80MTS-481		ALLEN HEAD CAP SCREW (M8x20)	4
82	055A-335		80MTS-482		PULLEY SPACER	1
83						
84						
85	055A-340		80MTS-485		PLATE SUPPORT	1
86						
87						
88						
89						
90		100MTS-490			ALLEN HEAD SCREW (M6x25)	4
91				80A-491	SPRING WASHER (M6)	4
92				80A-492	LOCK WASHER (M6)	4
93		100MTS-493			SPRING WASHER (M10)	6
94		100MTS-494			PLAIN WASHER (M10)	6
95	055A-714			80A-495	DUST COVER	
96				80A-496	ALLEN HEAD SCREW (M6x10)	4
97						
98	055A-220			80A-498	SUPPORT PLATE	1
99		100XY-499			ALLEN HEAD SCREW (M6x12)	4
100	055A-890-A	100XY-4100			CABLE CHANNEL (L.H.)	1
101	055A-890-B	100XY-4101			CABLE CHANNEL (R.H.)	1
102		100XY-4102			ALLEN HEAD SCREW (M4x12)	2
103		100MTS-4103			EXT. CIRCLIP (M37)	1
104		100MTS-4104			EXT. CIRCLIP (M48)	1
105	055A-183	100MTS-4105			DRIVER PULLEY	1
106	055A-099	100MTS-4106			CYL COVER	1
107			80MTS-4107		ALLEN HEAD SCREW (M6x30)	2
108	6908-2RS	100MTS-4108			BALL BEARING (40x62x12)	1

Fixture Assembly Parts

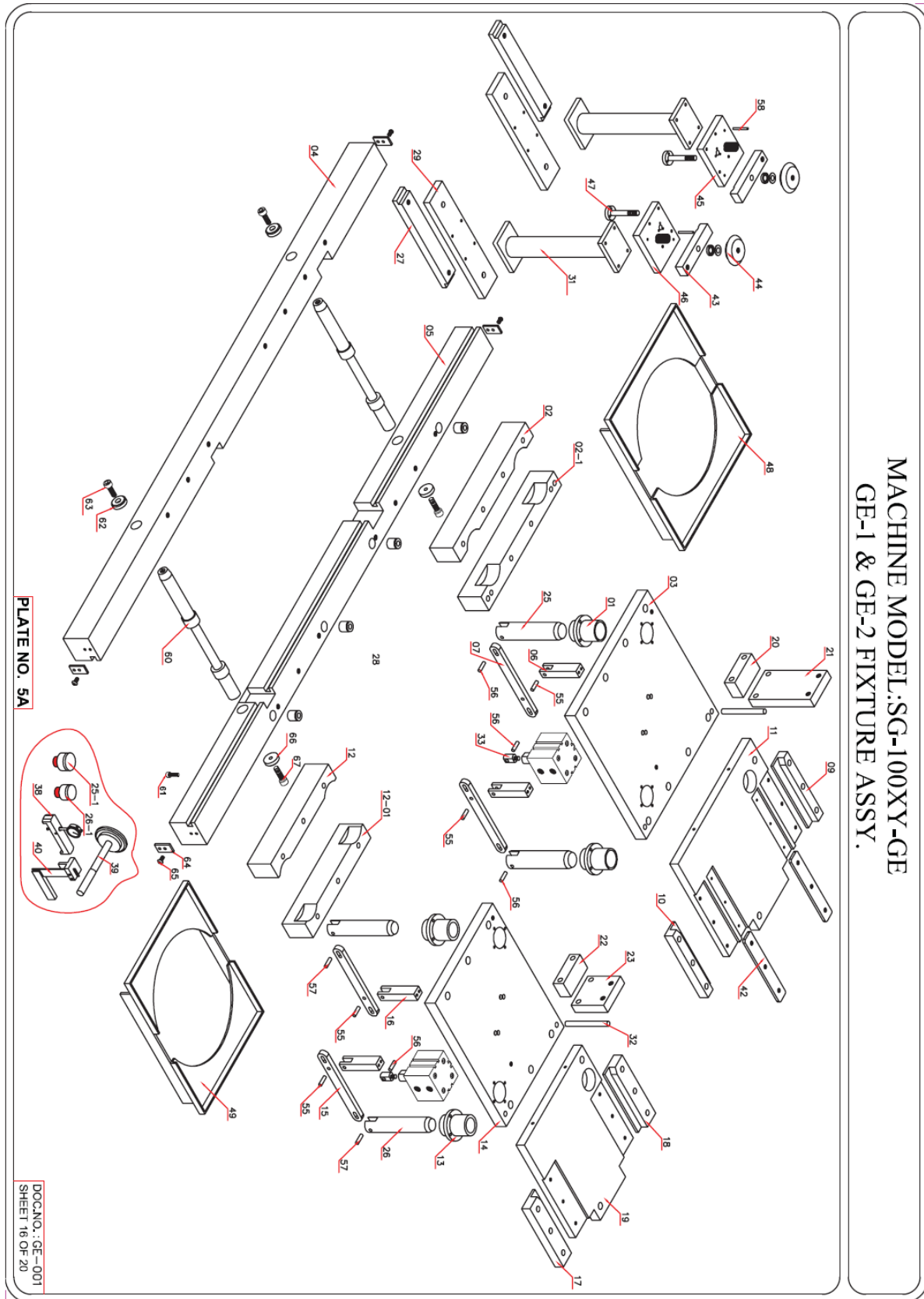

S. NO.	PART NO.	BIN NO. (SG-100XY)	DESCRIPTION	QTY
1	GE-01		BUSH	2
2	GE-02		SPACING FLAT (LEFT)	1
2-1	GE-02-1		SPACING FLAT (RIGHT)	1
3	GE-03		BASE PLATE	2
4	GE-04		PARALLEL BAR (LEFT)	1
5	GE-05		PARALLEL BAR (RIGHT)	1
6	GE-06		PIVOT BLOCK	2
7	GE-07		LEVER	2
8				
9	GE-09		NEST PLATE (LEFT)	1
10	GE-10		NEST PLATE (RIGHT)	1
11	GE-11		FLOAT PLATE	1
12	GE-12		SPACING FLAT (LEFT)	1
12-1	GE-12-1		SPACING FLAT (RIGHT)	1
13	GE-13		BUSH	2
14	GE-14		BASE PLATE	2
15	GE-15		LEVER	2
16	GE-16		PIVOT BLOCK	2
17	GE-17		NEST PLATE (RIGHT)	1
18	GE-18		NEST PLATE (LEFT)	1
19	GE-19		FLOAT PLATE	1
20	GE-20		SPACING BLOCK	1
21	GE-21		STOPPER PLATE	1
22	GE-22		SPACING BLOCK	1
23	GE-23		STOPPER PLATE	1
24				
25	GE-25		PIN	2
25-1	GE-25-1		CHECKING GAUGE	1
26	GE-26		PIN	2
26-1	GE-26-1		CHECKING GAUGE	1
27	GE-27		CLAMP FLAT	4
28	GE-28		LINER	4
29	GE-29		CLAMP SUPPORT	4
30				
31	GE-31		CYL. MTG. SUPPORT PLATE	4
32	GE-32		DOWEL PIN	4
33	GE-33		KNUCKLE PIN	2
34				
35				
36				
37				
38	GE-38		DEPTH GAUGE	1
39	GE-39		DEPTH GAUGE MANDREL ASSY.	1
40	GE-40		SETTING BLOCK	1
41				
42	GE-42		WEAR STRIP	2
43	GE-43		SWIVEL CLAMP	4
44	GE-44		KNOB	4
45	GE-45		SUPPORT PLATE (L.H.)	2
46	GE-46		SUPPORT PLATE (R.H.)	2
47	GE-47		PIVOT PIN	4
48	GE-48		CHIP TRAY	1
49	GE-49		CHIP TRAY	1
50				
51				
52				
53				

S. NO.	PART NO.	BIN NO. (SG-100XY)	DESCRIPTION	QTY
54				
55			PIN DIA 0.3125"x1.125"	4
56			PIN DIA 0.3125"x1.75"	4
57			PIN DIA 0.3125"x1.5"	2
58			PIN DIA 0.187"x2"	8
59				
60	055A-042	100XY-566	GUIDE ROD	2
61		100XY-563	ALLEN SCREW (M12x65)	8
62	055A-560	80MTS-567	END COVER	4
63		80MTS-568	ALLEN SCREW (M8x16)	4
64	055A-090	100XY-5161	END STOPPER	4
65		100XY-5162	AL. BUTTON HD. SCREW (M6x10)	8
66	055A-560	80MTS-567	END COVER	4
67		100XY-5156	AL. HD. CAP SCREW (M8x20)	2
68				
69				
70				
71				
72				
73				
74				
75				
76				
77				
78				
79				
80				
81				
82				
83				
84				
85				
86				
87				
88				
89				
90				
91				
92				
93				
94				
95				
96				
97				
98				
99				
100				
101				
102				
103				
104				
105				
106				
107				
108				

RBHAR1KIT Repair Kit for RBHAR1

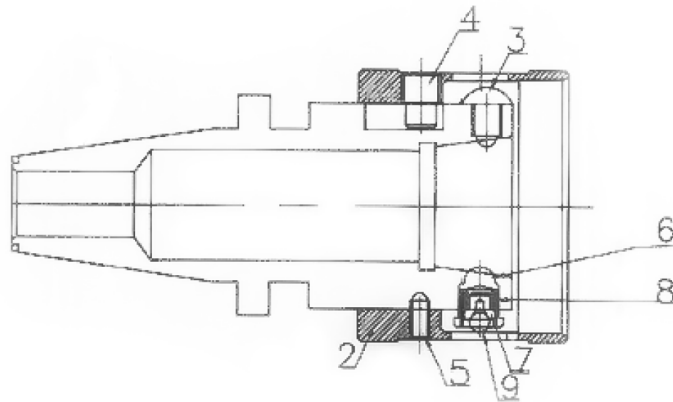

ITEM	PART NO.	DESCRIPTION	QTY
2	RBHAR1COL	Collar	1
3	555-19-19	Stop Screw	2
4	555-19-20	Dog Point Screw	2
5	555-19-21	Ball Point	2
6	555-19-22	Detent	4
7	555-19-23	Ball Seat	4
8	555-19-24	Spring	4
9	555-19-25	Ball (4mm)	4

RBHAR40UPCKIT Repair Kit for RBHAR40UPT

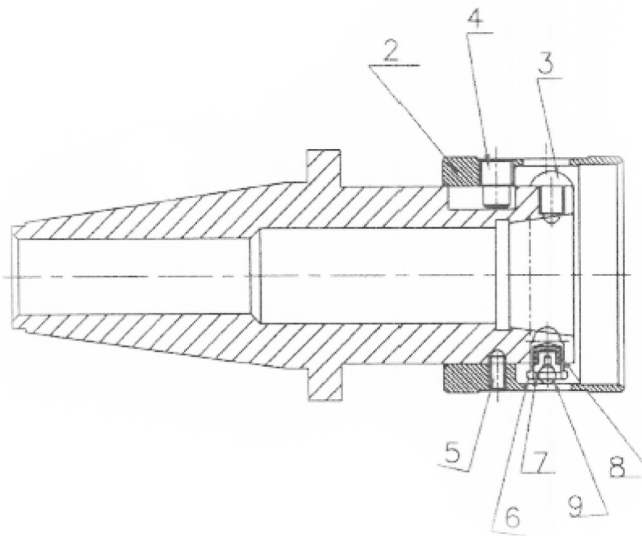

ITEM	PART NO.	DESCRIPTION	QTY
2	RBHAR40UPCCOL	Collar	1
3	555-19-19	Stop Screw	2
4	555-19-20	Dog Point Screw	2
5	555-19-21	Ball Point	2
6	555-19-22	Detent	4
7	555-19-23	Ball Seat	4
8	555-19-24	Spring	4
9	555-19-25	Ball (4mm)	4

Pneumatic Circuit Diagram

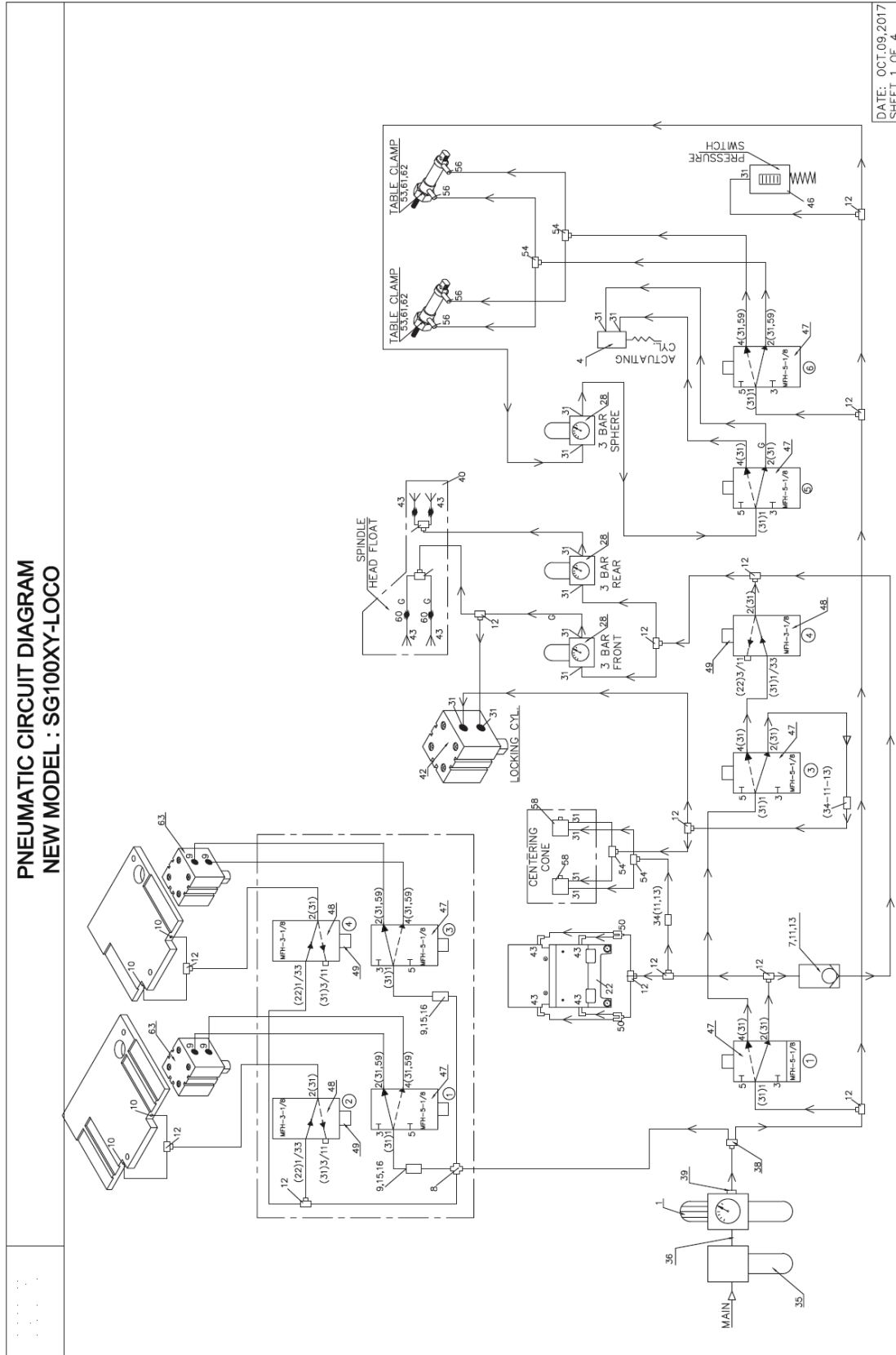

PART LIST (MODEL: SG-100XY)				
MACHINE TYPE: PNEUMATIC PARTS				
S. NO.	PART NO.	DESCRIPTION	QTY	REMARKS
1	162721	FILTER REGULATOR	1	LFR-3/8-D-5M-MIDI
2				
3				
4	536279	AIR CYLINDER B 008	1	ADN 32-10-1-P-A
5				
6				
7	3324	NON-RETURN VALVE	1	H-1/8 A/I
8	153380	X-CONNECTOR	1	QSMX-6
9	130918	PUSH-IN/THREADED FITTING	6	QS-B-1/4-6-20
10	153001	PUSH-IN/THREADED FITTING	4	QS-1/8-4
11	153002	PUSH-IN/THREADED FITTING	2	QS-1/8-6
12	130974	PUSH-IN T CONNECTOR	13	QST-B-6-20
13	153023	PUSH-IN/THREADED FITTING	3	QSF-1/8-6-B
14				
15	151172	FLOW CONTROL VALVE	2	GRLA-1-4-B
16	153024	PUSH-IN/THREADED FITTING	2	QSF-1/4-6-B
17				
18				
19				
20	90872110	MALE THREAD (VACUUM PAD)	6	
21	3569	INT. HEX HEAD PLUG ¼ NPT	1	
22	02851100	INT. HEX HEAD PLUG ¼ NPT	8	
23		TUBE 6x4 MM BLACK	16M	
24		TUBE 6x4 MM BLUE	10M	
25		TUBE 8x55 MM BLUE	2M	
26		TUBE 6x4 MM GREEN	13M	
26-1		TUBE 6x4 MM YELLOW	1M	
27				
28	159625	PRESSURE REGULATOR	3	LR-1/4-D-MINI
29				
30				
31	130930	PUSH-IN/THREADED L FITTING	29	QSL-1/4-6
32				
33				
34	151165	FLOW CONTROL VALVE	2	GRLA-1/8-B
35	159576	FILTER	1	LF-3/8-D-MIDI
36	15625	DOUBLE NIPPLE	1	E-3/8-3/8-MS
37				
38	153154	PUSH-IN Y CONNECTOR	1	QSY-8-6
39	153050	PUSH-IN/THREADED L FITTING	1	QS-3/8-8
40	3568	PLUG	8	1/8
41	536343	AIR CYLINDER	2	ADN-63-15-I-P
42	536393	AIR CYLINDER	1	ADN-125-15-I-P
43	132111	PUSH-IN/THREADED L FITTING	8	SMALL
44				
45				
46	10773	PRESSURE SWITCH	1	PEV-1/4-B
47	6211	SOLENOID VALVE	6	MFH-5-1/4
48	9964	SOLENOID VALVE	3	MFH-3-1/4
49	4540	SOLENOID COIL	6	MSFW-230 AC
50	153149	PUSH IN Y CONNECTOR	2	QSY-6
51				
52				
53	19210	TABLE CLAMP CYLINDER	2	DSNU-20-50-P-A
54	130973	PUSH-IN T CONNECTOR	4	QST-B-4
55				
56	130900	PUSH-IN/THREADED L FITTING	4	QSML-B-M5-4
57				
58	SMC	AIR CYLINDER	2	ICQ 2B32-15-D
59	153041	PUSH-IN CONNECTOR	4	QS-6H-4
60	153357	PUSH-IN T CONNECTOR	2	QSMT-1/8-6
61	36198(FESTO)	TABLE LOCK WIRE (PROX SENSOR)	2	SMED-4U-K-LED-24
62	19276(FESTO)	TABLE LOCK CLAMP (MOUNTING KIT)	2	SMBR-20
63		AIR CYLINDER	2	

Pneumatic Tubing Diagram

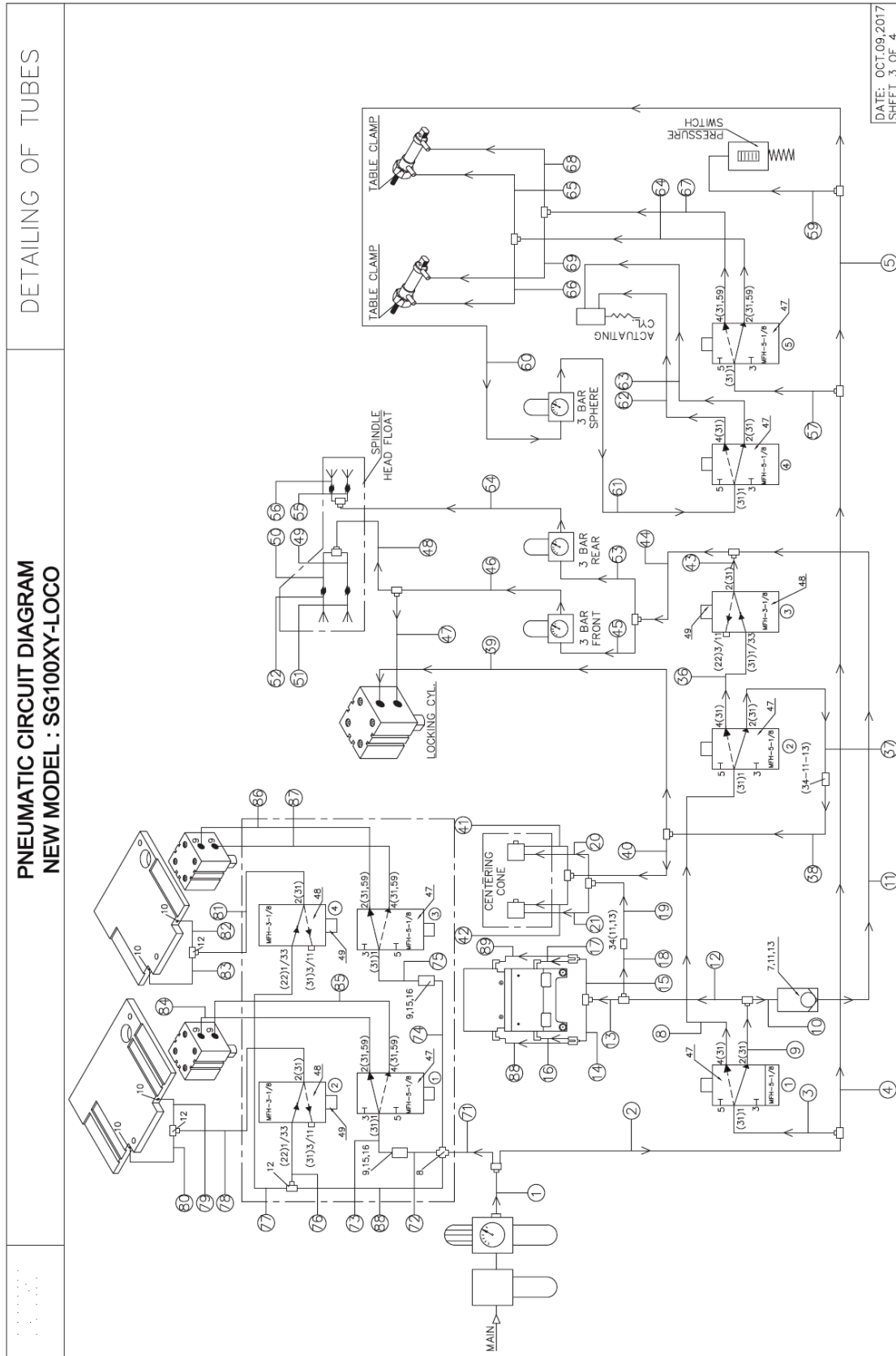

TUBE NO.	TUBE COLOR	TUBE DESCRIPTION	TUBE NO.	TUBE COLOR	TUBE DESCRIPTION
1	BLUE	M8x48"	51	GREEN	M6x8"
2	BLUE	M6x2"	52	GREEN	M6x8"
3	BLUE	M6x3"	53	YELLOW	M6x4"
4	BLUE	M6x30"	54	YELLOW	M6x200"
5	BLUE	M6x16.5"	55	YELLOW	M6x7"
6			56	YELLOW	M6x7"
7			57	BLUE	M6x2.5"
8	BLUE	M6x10"	58		
9	GREEN	M6x6"	59	BLUE	M6x4"
10	GREEN	M6x2"	60	BLUE	M6x80"
11	GREEN	M6x9"	61	BLUE	M6x100"
12	GREEN	M6x185"	62	GREEN	M6x237"
13	GREEN	M6x4"	63	BLUE	M6x237"
14	GREEN	M6x16"	64	BLACK	M4x2"
15	GREEN	M6x16"	65	BLACK	M4x90"
16	GREEN	M6x6"	66	BLACK	M4x110"
17	GREEN	M6x6"	67	GREEN	M4x2"
18	GREEN	M6x3"	68	GREEN	M4x90"
19	GREEN	M4x4"	69	GREEN	M4x110"
20	GREEN	M4x12"	70		
21	GREEN	M4x50"	71	BLUE	M6x80"
22			72	BLUE	M6x8"
23			73	BLUE	M6x8"
24			74	BLUE	M6x5"
25			75	BLUE	M6x5"
26			76	BLUE	M6x8"
27			77	BLUE	M6x6"
28			78	GREEN	M6x75"
29			79	GREEN	M6x5"
30			80	GREEN	M6x10"
31			81	GREEN	M6x60"
32			82	GREEN	M6x5"
33			83	GREEN	M6x10"
34			84	BLACK	M6x80"
35			85	GREEN	M6x80"
36	BLUE	M6x7.5"	86	BLACK	M6x65"
37	BLACK	M6x2"	87	GREEN	M6x65"
38	BLACK	M6x175"	88	BLUE	M6x5"
39	BLACK	M6x55"			
40	BLACK	M4x8"			
41	BLACK	M4x50"			
42	BLACK	M4x50"			
43	GREEN	M6x2"			
44	GREEN	M6x100"			
45	GREEN	M6x10"			
46	GREEN	M6x175"			
47	GREEN	M6x16"			
48	GREEN	M6x25"			
49	GREEN	M6x10"			
50	GREEN	M6x10"			

SDS

The Safety Data Sheets list shown in this section are the substances and materials that an operator is most likely to come in contact with while using this machine.

Other substances and materials are used in the manufacture, testing, and shipping of this machine. A complete list of the Safety Data Sheets of substances and materials used by Rottler Manufacturing during manufacturing, testing, and shipping is located on the Manual flash drive shipped with the machine.

Safety Data Sheets are also located on the company web site:

<http://www.rottlermfg.com/documentation.php>

- 1) **Way Oil**
- 2) **Multi-Purpose EP Grease**

Safety Data Sheet

According to OSHA HCS 2012 (29 CFR 1910.1200)
Health Canada HPR (SOR/2015-17), and
Mexico NOM-018-STPS-2015



SECTION 1: Identification

Product Identifier:	Multi-Way Oil HD
Other means of identification:	Phillips 66 Multi-Way Oil HD 22 Phillips 66 Multi-Way Oil HD 32
Code:	LBPH81776
Relevant identified uses:	Way Oil
Uses advised against:	All others
24 Hour Emergency Phone Number:	CHEMTREC: 1-800-424-9300 CHEMTREC Mexico: 01-800-681-9531

Manufacturer/Supplier	SDS Information	Customer Service
Phillips 66 Lubricants	URL: www.phillips66.com/SDS	U.S.: 800-368-7128
P.O. Box 4428	Phone: 800-762-0942	International: 1-832-765-2500
Houston, TX 77210	Email: SDS@P66.com	Technical Information
		1-877-445-9198

SECTION 2: Hazard Identification

Classified Hazards	Hazards Not Otherwise Classified (HNOC)
No classified hazards	PHNOC: None known HHNOC: None known
Label Elements	
No classified hazards	

SECTION 3: Composition/Information on Ingredients

Chemical Name	CASRN	Concentration
Distillates, petroleum, hydrotreated heavy paraffinic	64742-54-7	>40%
Distillates, petroleum, solvent-dewaxed heavy paraffinic	64742-65-0	>40%
Residual oils, petroleum, solvent-dewaxed	64742-62-7	>10%

All concentrations are percent by weight unless ingredient is a gas. Gas concentrations are in percent by volume.

SECTION 4: First Aid Measures

Eye Contact: If irritation or redness develops from exposure, flush eyes with clean water. If symptoms persist, seek medical attention.

Skin Contact: Remove contaminated shoes and clothing and cleanse affected area(s) thoroughly by washing with mild soap and water or a waterless hand cleaner. If irritation or redness develops and persists, seek medical attention.

Inhalation: First aid is not normally required. If breathing difficulties develop, move victim away from source of exposure and into fresh air in a position comfortable for breathing. Seek immediate medical attention.

Ingestion: First aid is not normally required; however, if swallowed and symptoms develop, seek medical attention

Most important symptoms and effects, both acute and delayed: Inhalation of oil mists or vapors generated at elevated temperatures may cause respiratory irritation. Accidental ingestion can result in minor irritation of the digestive tract, nausea, and diarrhea. Prolonged or repeated contact may dry skin and cause irritation.

Notes to Physician: Acute aspirations of large amounts of oil-laden material may produce a serious aspiration pneumonia. Patients who aspirate these oils should be followed for the development of long-term sequelae. Inhalation exposure to oil mists below current workplace exposure limits is unlikely to cause pulmonary abnormalities.

SECTION 5: Firefighting Measures

NFPA 704: National Fire Protection Association		
Health: 0 Flammability: 1 Instability: 00=minimal hazard		1=Slight Hazard
		2=Moderate Hazard
		3=Severe Hazard
		4=Extreme Hazard

Extinguishing Media: Dry chemical, carbon dioxide, foam, or water spray is recommended. Water or foam may cause frothing of materials heated above 212°F/100°C. Carbon dioxide can displace oxygen. Use caution when applying carbon dioxide in confined spaces. Simultaneous use of foam and water on the same surface is to be avoided as water destroys the foam.

Specific Hazards arising from the chemical:

Unusual Fire & Explosion Hazards: This material may burn but will not ignite readily. If container is not properly cooled, it can rupture in the heat of a fire.

Hazardous Combustion Products: Combustion may yield smoke, carbon monoxide, and other products of incomplete combustion. Oxides of sulfur, nitrogen, or phosphorus may also be formed.

Special protective actions for firefighters: For fires beyond the initial stage, emergency responders in the immediate hazard area should wear protective clothing. When the potential chemical hazard is unknown, in enclosed or confined spaces, a self-contained breathing apparatus should be worn. In addition, wear other appropriate protective equipment as conditions warrant (see Section 8). Isolate the hazard area and deny entry to unnecessary and unprotected personnel. Stop spill/release if it can be done safely. Move undamaged containers from immediate hazard area if it can be done safely. Water spray may be useful in minimizing or dispersing vapors and to protect personnel. Cool equipment exposed to fire with water if it can be done safely. Avoid spreading burning liquid with water used for cooling purposes.

See Section 9 for Flammability Properties including flash point and flammable (explosive) limits.

SECTION 6: Accidental Release Measures

Personal precautions, protective equipment, and emergency procedures: This material may burn but will not ignite readily. Keep all sources of ignition away from spill/release. Stay upwind and away from spill/release. Avoid direct contact with material. For large spillages, notify persons downwind of the spill/release, isolate immediate hazard area, and keep unauthorized personnel out. Wear appropriate protective equipment, including respiratory protection, as conditions warrant (see Section 8). See Sections 2 and 7 for additional information on hazards and precautionary measures.

Environmental Precautions: Stop and contain spill/release if it can be done safely. Prevent spilled material from entering sewers, storm drains, other unauthorized drainage systems, and natural waterways. Use water sparingly to minimize environmental contamination and reduce disposal requirements. If spill occurs on water, notify appropriate authorities and advise shipping of any hazard. Spills into or upon navigable waters, the contiguous zone, or adjoining shorelines that cause a sheen or discoloration on the surface of the water may require notification of the National Response Center (Phone number: 800-424-8802).

Methods and material for containment and cleaning up: Notify relevant authorities in accordance with all applicable regulations. Immediate cleanup of any spill is recommended. Dike far ahead of spill for later recovery or disposal. Absorb spill with inert material such as sand or vermiculite and place in suitable container for disposal. If spilled on water, remove with appropriate methods (e.g. skimming, booms, or absorbents). In case of soil contamination, remove contaminated soil for remediation or disposal in accordance with local regulations.

Recommended measures are based on the most likely spillage scenarios for this material; however, local conditions and regulations may influence or limit the choice of appropriate actions to be taken. See Section 13 for information on appropriate disposal.

SECTION 7: Handling and Storage

Precautions for Safe Handling: Keep away from flames and hot surfaces. Wash thoroughly after handling. Use good personal hygiene practices and wear appropriate personal protective equipment (see Section 8). Spills will produce very slippery surfaces. Do not enter confined spaces such as tanks or pits without following proper entry procedures such as ASTM D-4276 and 29 CFR 1910.146. Do not wear contaminated clothing or shoes.

Conditions for Safe Storage: Keep container(s) tightly closed and properly labeled. Use and store this material in cool, dry, well-ventilated areas away from heat and all sources of ignition. Store only in approved containers. Keep away from any incompatible material (see Section 10). Protect container(s) against physical damage.

“Empty” containers retain residue and may be dangerous. Do not pressurize, cut, weld, braze, solder, drill, grind, or expose such containers to heat, flame, sparks, or other sources of ignition. They may explode and cause injury or death. “Empty” drums should be completely drained, properly bunged, and promptly shipped to the supplier or a drum reconditioner. All containers should be disposed of in an environmentally safe manner and in accordance with governmental regulations. Before working on or in tanks which contain or have contained this material, refer to OSHA regulations, ANSI Z49.1, and other references pertaining to cleaning, repairing, welding, or other contemplated operations.

SECTION 8: Exposure Controls/Personal Protection

Occupational exposure limits				
The following constituents are the only constituents of the product which have a PEL, TLV or other recommended exposure limit. At this time the other constituents have no known exposure limits.				
Chemical Name	ACGIH	OSHA	Mexico	Phillips 66
Distillates, petroleum, hydrotreated heavy paraffinic	TWA: 5mg/m ³ STEL: 10 mg/m ³ as Oil Mist, if Generated	---	---	---
Distillates, petroleum, solvent-dewaxed heavy paraffinic	TWA: 5mg/m ³ STEL: 10 mg/m ³ as Oil Mist, if Generated	---	---	---
Residual oils, petroleum, solvent-dewaxed	TWA: 5mg/m ³ STEL: 10 mg/m ³ as Oil Mist, if Generated	---	---	---

Note: State, Local, or other agencies or advisory groups may have established more stringent limits. Consult an industrial hygienist or similar professional, or you local agencies, for further information.

Biological Occupational Exposure Limits

Note: This product, as supplied, does not contain any hazardous materials with occupational exposure limits established by the region-specific regulatory bodies

Engineering Controls: If current ventilation practices are not adequate to maintain airborne concentrations below the established exposure limits, additional engineering controls may be required.

Eye/Face Protection: The use of eye/face protection is not normally required; however, good industrial hygiene practice suggests the use of eye protection that meets or exceeds ANSI Z.87.1 whenever working with chemicals.

Skin/Hand Protection: The use of skin protection is not normally required; however, good industrial hygiene practice suggests the use of gloves or other appropriate skin protection whenever working with chemicals. Suggested protective materials: Nitrile rubber.

Respiratory Protection: Where there is potential for airborne exposure above the exposure limit, a NIOSH certified air purifying respirator equipped with R or P95 filters may be used.

A respiratory protection program that meets or is equivalent to OSHA 29 CFR 1910.134 and ANSI Z88.2 should be followed whenever workplace conditions warrant a respirator's use. Air purifying respirators provide limited protection and cannot be used in atmospheres that exceed the maximum use concentration (as directed by regulation or the manufacturer's instructions), in oxygen deficient (less than 19.5% oxygen) situations, or under conditions that are immediately dangerous to life and health (IDLH).

Suggestions provided in this section for exposure control and specific types of protective equipment are based on readily available information. Users should consult with the specific manufacturer to confirm the performance of their protective equipment. Specific situations may require consultation with industrial hygiene, safety, or engineering professionals.

SECTION 9: Physical and Chemical Properties

Note: Unless otherwise stated, values are determined at 20°C (68°F) and 760 mmHg (1atm). Data represent typical values and are not intended to be specifications.

Appearance:	Amber, Transparent	Flash Point:	> 320°F (160°C)
Physical Form:	Liquid	Test Method:	Pensky-Martens Closed Cup (PMCC), ASTM D93, EPA 1010
Odor:	Petroleum	Initial Boiling Point/Range:	No Data
Odor Threshold:	No Data	Vapor Pressure:	< 1mmHg
pH:	Not applicable	Partition Coefficient (n-octanol/water)(Kow):	No Data
Vapor Density (1=air):	>1	Melting/Freezing Point:	< -5°F (-15°C)
Upper Explosive Limits (vol % in air):	No Data	Auto-ignition Temperature:	No Data
Lower Explosive Limits (vol % in air):	No Data	Decomposition Temperature:	No Data
Evaporation Rate (nBuAc=1):	No Data	Specific Gravity (water=1):	0.86-0.89 @ 60°F (15.6°C)
Particle Size:	Not applicable	Bulk Density:	7.2-7.4 lbs/gal
Percent Volatile:	No Data	Viscosity:	5-20 cSt @ 100°C; 29-235 cSt @ 40°C
Flammability (solid, gas):	Not applicable	Pour Point:	< -5°F (-15°C)
Solubility in Water:	Insoluble		

SECTION 10: Stability and Reactivity

Reactivity: Not chemically reactive.

Chemical Stability: Stable under normal ambient and anticipated conditions of use.

Possibility of Hazardous Reactions: Hazardous reactions not anticipated.

Conditions to Avoid: Extended exposure to high temperatures can cause decomposition. Avoid all possible sources of ignition.

Incompatible Materials: Avoid contact with strong oxidizing agents and strong reducing agents.

Hazardous Decomposition Products: Not anticipated under normal conditions of use.

SECTION 11: Toxicological Information

Information on Toxicological Effects

Acute Toxicity	Hazard	Additional Information	LC50/LD50 Data
Inhalation	Unlikely to be harmful		>5 mg/L (mist, estimated)
Dermal	Unlikely to be harmful		>2 g/kg (estimated)
Oral	Unlikely to be harmful		>5 g/kg (estimated)

Likely Routes of Exposure: Inhalation, eye contact, skin contact

Aspiration Hazard: Not expected to be an aspiration hazard

Skin Corrosion/Irritation: Not expected to be irritating. Repeated exposure may cause skin dryness or cracking

Serious Eye Damage/Irritation: Not expected to be irritating

Skin Sensitization: No information available on the mixture, however none of the components have been classified for skin sensitization (or are below the concentration threshold for classification)

Respiratory Sensitization: No information available

Specific Target Organ Toxicity (Single Exposure): Not expected to cause organ effects from single exposure

Specific Target Organ Toxicity (Repeated Exposure): Not expected to cause organ effects from repeated exposure

Carcinogenicity: No information available on the mixture, however none of the components have been classified for carcinogenicity (or are below the concentration threshold for classification)

Germ Cell Mutagenicity: No information available on the mixture, however none of the components have been classified for germ cell mutagenicity (or are below the concentration threshold for classification)

Reproductive Toxicity: No information available on the mixture, however none of the components have been classified for reproductive toxicity (or are below the concentration threshold for classification)

Information on Toxicological Effects of Components

Distillates, petroleum, hydrotreated heavy paraffinic

Carcinogenicity: This oil has been highly refined by a variety of process to reduce aromatics and improve performance characteristics. It meets the IP-346 criteria of less than 3 percent PAH's and is not considered a carcinogen by the International Agency for Research on Cancer.

SECTION 12: Ecological Information

GHS Classification: No classified hazards

Toxicity: All acute aquatic toxicity studies on samples of lubricant base oils show acute toxicity values greater than 100 mg/L for invertebrates, algae, and fish. These tests were carried out on water accommodated fractions and the results are consistent with the predicted aquatic toxicity of these substances based on their hydrocarbon compositions.

Persistence and Degradability: The hydrocarbons in this material are not readily biodegradable, but since they can be degraded by microorganisms, they are regarded as inherently biodegradable.

Bioaccumulative Potential: Log Kow values measured for the hydrocarbon components of this material are greater than 5.3, and therefore regarded as having the potential to bioaccumulate. In practice, metabolic processes may reduce bioconcentration.

Mobility in Soil: Volatilization to air is not expected to be a significant fate process due to the low vapor pressure of this material. In water, base oils will float and spread over the surface at a rate dependent on viscosity. There will be significant removal of hydrocarbons from the water by sediment absorption. In soil and sediment, hydrocarbon components will show low mobility with absorption to sediments being the predominant physical process. The main process is expected to be slow biodegradation of the hydrocarbon constituents in soil and sediment.

Other Adverse Effects: None anticipated.

SECTION 13: Disposal Considerations

The generator of a waste is always responsible for making proper hazardous waste determinations and needs to consider state and local requirements in addition to federal regulations. This material, if discarded as produced, would not be a federally regulated RCRA "listed" hazardous waste and is not believed to exhibit characteristics of hazardous waste. See Sections 7 and 8 for information on handling, storage and personal protection and Section 9 for physical/chemical properties. It is possible that the material as produced contains constituents which are not required to be listed in the SDS but could affect the hazardous waste determination. Additionally, use which results in chemical or physical change of this material could subject it to regulation as a hazardous waste. This material under most intended uses would become "Used Oil" due to contamination by physical or chemical impurities. Whenever possible, Recycle used oil in accordance with applicable federal and state or local regulations. Container contents should be completely used, and containers should be emptied prior to discard.

SECTION 14: Transport Information

U.S. Department of Transportation (DOT)

UN Number:	Not regulated
UN Proper Shipping Name:	None
Transport Hazard Class(es):	None
Packing Group:	None
Environmental Hazards:	This product does not meet the DOT/UN/IMDG/IMO criteria of a marine pollutant
Special Precautions for User:	If shipped by land in a packaging having capacity of 3,500 gallons or more, the provisions of 49 CFR, Part 130 apply (contains oil).

Transport in Bulk according to Annex II of MARPOL 73/78 and the IBC Code: Not applicable

SECTION 15: Regulatory Information

CERCLA/SARA – Section 302: Extremely Hazardous Substances and TPQs (in pounds)

This material does not contain any chemicals subject to the reporting requirements of SARA 302 and 40 CFR 372.

CERCLA/SARA – Section 311/312 (Title III Hazard Categories)

Should this product meet EPCRA 311/312 Tier reporting criteria at 40 CFR 370, refer to Section 2 of this SDS for appropriate classifications.

CERCLA/SARA – Section 313 and 40 CFR 372

This material does not contain any chemicals subject to the reporting requirements of SARA 313 and 40 CFR 372.

EPA (CERCLA) Reportable Quantity (in pounds)

This material does not contain any chemicals with CERCLA Reportable Quantities.

California Proposition 65

This material does not contain any chemicals which are known to the State of California to cause cancer, birth defects, or other reproductive harm at concentrations that trigger the warning requirements of California Proposition 65.

International Inventories

All components are either listed on the US TSCA inventory or are not regulated under TSCA.

All components are either on the DSL or are exempt from DSL listing requirements.

SECTION 16: Other Information

Issue Date:	Previous Issue Date:	SDS Number	Status:
16-Apr-2018	23-Jun-2016	LBPH81776	FINAL

Revised Sections or Basis for Revision:

Exposure limits (Section 8); Regulatory information (Section 15)

Legend (pursuant to NOM-018-STPS-2015):

The information within is considered correct but is not exhaustive and will be used for guidance only, which is based on the current knowledge of the substance or mixture and is applicable to the appropriate safety precautions for the product.

Guide to Abbreviations:

ACGIH = American Conference of Governmental Industrial Hygienists; CASRN = Chemical Abstracts Service Registry Number; CEILING = Ceiling Limit (15 minutes); CERCLA = The Comprehensive Environmental Response, Compensation, and Liability Act; EPA = Environmental Protection Agency; GHS = Globally Harmonized System; HPR = Hazardous Products Regulations; IARC = International Agency for Research on Cancer; INSHT = National Institute for Health and Safety at Work; IOPC = International Oil Pollution Compensation; LEL = Lower Explosive Limit; NE = Not Established; NFPA = National Fire Protection Association; NTP = National Toxicology Program; OSHA = Occupational Safety and Health Administration; PEL = Permissible Exposure Limit (OSHA); SARA = Superfund Amendments and Reauthorization Act; STEL = Short Term Exposure Limit (15 minutes); TLV = Threshold Limit Value (ACGIH); TWA = Time Weighted Average (8 hours); UEL = Upper Explosive Limit; WHMIS = Worker Hazardous Materials Information System (Canada)

Disclaimer of Expressed and Implied Warranties:

The information presented in this Safety Data Sheet is based on data believed to be accurate as of the date this Safety Data Sheet was prepared. HOWEVER, NO WARRANTY OF MERCHANTABILITY, FITNESS FOR ANY PARTICULAR PURPOSE, OR ANY OTHER WARRANTY IS EXPRESSED OR IS TO BE IMPLIED REGARDING THE ACCURACY OR COMPLETENESS OF THE INFORMATION PROVIDED ABOVE, THE RESULTS TO BE OBTAINED FROM THE USE OF THIS INFORMATION OR THE PRODUCT, THE SAFETY OF THIS PRODUCT, OR THE HAZARDS RELATED TO ITS USE. No responsibility is assumed for any damage or injury resulting from abnormal use or from any failure to adhere to recommended practices. The information provided above, and the product, are furnished on the condition that the person receiving them shall make their own determination as to the suitability of the product for their particular purpose and on the condition that they assume the risk of their use. In addition, no authorization is given nor implied to practice any patented invention without a license.

Safety Data Sheet

According to OSHA HCS 2012 (29 CFR 1910.1200)
Health Canada HPR (SOR/2015-17), and
Mexico NOM-018-STPS-2015



SECTION 1: Identification

Product Identifier:	Alco Super-Lube Multi-Purpose EP-0 Grease
Other means of identification:	
Code:	829364
Relevant identified uses:	Lubricating Grease
Uses advised against:	All others
24 Hour Emergency Phone Number:	CHEMTREC: 1-800-424-9300 CHEMTREC Mexico: 01-800-681-9531

Manufacturer/Supplier	SDS Information	Customer Service
Phillips 66 Spectrum Corporation	URL: www.phillips66.com/SDS	U.S.: 800-368-7128
500 Industrial Park Drive	Phone: 800-762-0942	International: 1-832-765-2500
Selmer, TN 38375-3276	Email: SDS@P66.com	Technical Information
		1-800-264-6457 or +1-731-645-7972

SECTION 2: Hazard Identification

Classified Hazards	Hazards Not Otherwise Classified (HNOC)
No classified hazards	PHNOC: None known HHNOC: None known
Label Elements	
No classified hazards	

SECTION 3: Composition/Information on Ingredients

Chemical Name	CASRN	Concentration
Distillates, petroleum, hydrotreated heavy naphthenic	64742-52-5	40-70%
Distillates, petroleum, hydrotreated heavy paraffinic	64742-54-7	20-40%
Boron lithium oxide	12007-60-2	< 4%

All concentrations are percent by weight unless ingredient is a gas. Gas concentrations are in percent by volume.

SECTION 4: First Aid Measures

Eye Contact: If irritation or redness develops from exposure, flush eyes with clean water. If symptoms persist, seek medical attention.

Skin Contact: Remove contaminated shoes and clothing and cleanse affected area(s) thoroughly by washing with mild soap and water or a waterless hand cleaner. If irritation or redness develops and persists, seek medical attention. If product is injected into or under the skin, or into any part of the body, regardless of appearance of the wound or its size, the individual should be evaluated immediately by a physician. (see Note to Physician)

Inhalation: First aid is not normally required. If breathing difficulties develop, move victim away from source of exposure and into fresh air in a position comfortable for breathing. Seek immediate medical attention.

Ingestion: First aid is not normally required; however, if swallowed and symptoms develop, seek medical attention

Most important symptoms and effects, both acute and delayed: Inhalation of oil mists or vapors generated at elevated temperatures may cause respiratory irritation. Accidental ingestion can result in minor irritation of the digestive tract, nausea, and diarrhea. Prolonged or repeated contact may dry skin and cause irritation.

Notes to Physician: When using high-pressure equipment, injection of product under the skin can occur. In this case, the casualty should be sent immediately to the hospital. Do not wait for symptoms to develop. High-pressure hydrocarbon injection injuries may produce substantial necrosis of underlying tissue despite an innocuous appearing external wound. These injuries often require extensive emergency surgical debridement and all injuries should be evaluated by a specialist in order to assess the extent of injury. Early surgical treatment within the first few hours may significantly reduce the ultimate extent of injury

SECTION 5: Firefighting Measures

NFPA 704: National Fire Protection Association		
Health: 0 Flammability: 1 Instability: 00=minimal hazard		1=Slight Hazard
		2=Moderate Hazard
		3=Severe Hazard
		4=Extreme Hazard

Extinguishing Media: Dry chemical, carbon dioxide, foam, or water spray is recommended. Water or foam may cause frothing of materials heated above 212°F/100°C. Carbon dioxide can displace oxygen. Use caution when applying carbon dioxide in confined spaces. Simultaneous use of foam and water on the same surface is to be avoided as water destroys the foam.

Specific Hazards arising from the chemical:

Unusual Fire & Explosion Hazards: This material may burn but will not ignite readily. If container is not properly cooled, it can rupture in the heat of a fire.

Hazardous Combustion Products: Combustion may yield smoke, carbon monoxide, and other products of incomplete combustion. Oxides of sulfur, nitrogen, or phosphorus may also be formed.

Special protective actions for firefighters: For fires beyond the initial stage, emergency responders in the immediate hazard area should wear protective clothing. When the potential chemical hazard is unknown, in enclosed or confined spaces, a self-contained breathing apparatus should be worn. In addition, wear other appropriate protective equipment as conditions warrant (see Section 8). Isolate the hazard area and deny entry to unnecessary and unprotected personnel. Stop spill/release if it can be done safely. Move undamaged containers from immediate hazard area if it can be done safely. Water spray may be useful in minimizing or dispersing vapors and to protect personnel. Cool equipment exposed to fire with water if it can be done safely. Avoid spreading burning liquid with water used for cooling purposes.

See Section 9 for Flammability Properties including flash point and flammable (explosive) limits.

SECTION 6: Accidental Release Measures

Personal precautions, protective equipment, and emergency procedures: This material may burn but will not ignite readily. Keep all sources of ignition away from spill/release. Stay upwind and away from spill/release. Avoid direct contact with material. For large spillages, notify persons downwind of the spill/release, isolate immediate hazard area, and keep unauthorized personnel out. Wear appropriate protective equipment, including respiratory protection, as conditions warrant (see Section 8). See Sections 2 and 7 for additional information on hazards and precautionary measures.

Environmental Precautions: Stop and contain spill/release if it can be done safely. Prevent spilled material from entering sewers, storm drains, other unauthorized drainage systems, and natural waterways. Use water sparingly to minimize environmental contamination and reduce disposal requirements. If spill occurs on water, notify appropriate authorities and advise shipping of any hazard. Spills into or upon navigable waters, the contiguous zone, or adjoining shorelines that cause a sheen or discoloration on the surface of the water may require notification of the National Response Center (Phone number: 800-424-8802).

Methods and material for containment and cleaning up: Notify relevant authorities in accordance with all applicable regulations. Immediate cleanup of any spill is recommended. Dike far ahead of spill for later recovery or disposal. Absorb spill with inert material such as sand or vermiculite and place in suitable container for disposal. If spilled on water, remove with appropriate methods (e.g. skimming, booms, or absorbents). In case of soil contamination, remove contaminated soil for remediation or disposal in accordance with local regulations.

Recommended measures are based on the most likely spillage scenarios for this material; however, local conditions and regulations may influence or limit the choice of appropriate actions to be taken. See Section 13 for information on appropriate disposal.

SECTION 7: Handling and Storage

Precautions for Safe Handling: Keep away from flames and hot surfaces. Wash thoroughly after handling. Use good personal hygiene practices and wear appropriate personal protective equipment (see Section 8). High pressure injection of hydrocarbon fuels, hydraulic oils, or greases under the skin may have serious consequences even though no symptoms or injury may be apparent. This can happen accidentally when using high pressure equipment such as high pressure grease guns, fuel injection apparatus, or from pinhole leaks in tubing of high pressure hydraulic oil equipment.

Do not enter confined spaces such as tanks or pits without following proper entry procedures such as ASTM D-4276 and 29 CFR 1910.146. Do not wear contaminated clothing or shoes.

Conditions for Safe Storage: Keep container(s) tightly closed and properly labeled. Use and store this material in cool, dry, well-ventilated areas away from heat and all sources of ignition. Store only in approved containers. Keep away from any incompatible material (see Section 10). Protect container(s) against physical damage.

“Empty” containers retain residue and may be dangerous. Do not pressurize, cut, weld, braze, solder, drill, grind, or expose such containers to heat, flame, sparks, or other sources of ignition. They may explode and cause injury or death. “Empty” drums should be completely drained, properly bunged, and promptly shipped to the supplier or a drum reconditioner. All containers should be disposed of in an environmentally safe manner and in accordance with governmental regulations. Before working on or in tanks which contain or have contained this material, refer to OSHA regulations, ANSI Z49.1, and other references pertaining to cleaning, repairing, welding, or other contemplated operations.

SECTION 8: Exposure Controls/Personal Protection

Occupational exposure limits				
The following constituents are the only constituents of the product which have a PEL, TLV or other recommended exposure limit. At this time the other constituents have no known exposure limits.				
Chemical Name	ACGIH	OSHA	Mexico	Phillips 66
Distillates, petroleum, hydrotreated heavy naphthenic	TWA: 5mg/m ³ STEL: 10 mg/m ³ as Oil Mist, if Generated	---	---	---
Distillates, petroleum, hydrotreated heavy paraffinic	TWA: 5mg/m ³ STEL: 10 mg/m ³ as Oil Mist, if Generated	---	---	---

Note: State, Local, or other agencies or advisory groups may have established more stringent limits. Consult an industrial hygienist or similar professional, or you local agencies, for further information.

Engineering Controls: If current ventilation practices are not adequate to maintain airborne concentrations below the established exposure limits, additional engineering controls may be required.

Eye/Face Protection: The use of eye protection that meets or exceeds ANSI Z.87.1 is recommended to protect against potential eye contact, irritation, or injury. Depending on conditions of use, a face shield may be necessary.

Skin/Hand Protection: The use of gloves impervious to the specific material handled is advised to prevent skin contact. Users should check with manufacturers to confirm the breakthrough performance of their products.

Respiratory Protection: Respiratory protection is not normally required under intended conditions of use. Emergencies or conditions that could result in significant airborne exposures may require the use of NIOSH approved respiratory protection. An industrial hygienist or other appropriate health and safety professional should be consulted for specific guidance under these situations.

Suggestions provided in this section for exposure control and specific types of protective equipment are based on readily available information. Users should consult with the specific manufacturer to confirm the performance of their protective equipment. Specific situations may require consultation with industrial hygiene, safety, or engineering professionals.

SECTION 9: Physical and Chemical Properties

Note: Unless otherwise stated, values are determined at 20°C (68°F) and 760 mmHg (1atm). Data represent typical values and are not intended to be specifications.

Appearance:	Green	Flash Point:	257°F / 125°C
Physical Form:	Semi-Solid	Test Method:	Cleveland Open Cup (COC), ASTM D92
Odor:	Slight hydrocarbon	Initial Boiling Point/Range:	No Data
Odor Threshold:	No Data	Vapor Pressure:	< 1mmHg
pH:	Not applicable	Partition Coefficient (n-octanol/water)(Kow):	No Data
Vapor Density (1=air):	<1	Melting/Freezing Point:	No Data
Upper Explosive Limits (vol % in air):	No Data	Auto-ignition Temperature:	No Data
Lower Explosive Limits (vol % in air):	No Data	Decomposition Temperature:	No Data
Evaporation Rate (nBuAc=1):	No Data	Specific Gravity (water=1):	0.87 @ 60°F (15.6°C)
Particle Size:	Not applicable	Bulk Density:	7.5lbs/gal
Percent Volatile:	No Data	Viscosity:	No Data
Flammability (solid, gas):	Not applicable	Solubility in Water:	Negligible

SECTION 10: Stability and Reactivity

Reactivity: Not chemically reactive.

Chemical Stability: Stable under normal ambient and anticipated conditions of use.

Possibility of Hazardous Reactions: Hazardous reactions not anticipated.

Conditions to Avoid: Extended exposure to high temperatures can cause decomposition. Avoid all possible sources of ignition.

Incompatible Materials: Avoid contact with strong oxidizing agents and strong reducing agents.

Hazardous Decomposition Products: Not anticipated under normal conditions of use.

SECTION 11: Toxicological Information

Information on Toxicological Effects

Acute Toxicity	Hazard	Additional Information	LC50/LD50 Data
Inhalation	Unlikely to be harmful		>5 mg/L (mist, estimated)
Dermal	Unlikely to be harmful		>2 g/kg (estimated)
Oral	Unlikely to be harmful		>5 g/kg (estimated)

Aspiration Hazard: Not expected to be an aspiration hazard

Skin Corrosion/Irritation: Causes mild skin irritation. Repeated exposure may cause skin dryness or cracking

Serious Eye Damage/Irritation: Causes mild eye irritation.

Skin Sensitization: No information available on the mixture, however none of the components have been classified for skin sensitization (or are below the concentration threshold for classification)

Respiratory Sensitization: No information available

Specific Target Organ Toxicity (Single Exposure): Not expected to cause organ effects from single exposure

Specific Target Organ Toxicity (Repeated Exposure): Not expected to cause organ effects from repeated exposure

Carcinogenicity: No information available on the mixture, however none of the components have been classified for carcinogenicity (or are below the concentration threshold for classification)

Germ Cell Mutagenicity: No information available on the mixture, however none of the components have been classified for germ cell mutagenicity (or are below the concentration threshold for classification)

Reproductive Toxicity: No information available on the mixture, however none of the components have been classified for reproductive toxicity (or are below the concentration threshold for classification)

Information on Toxicological Effects of Components

Lubricant Base Oil (Petroleum)

Carcinogenicity: The petroleum base oils contained in this product have been highly refined by a variety of processes, including severe hydrocracking/hydroprocessing to reduce the aromatics and improve performance characteristics. All of the oils met the IP-346 criteria of less than 3 percent PAH's and are not considered carcinogens by NTP, IARC, or OSHA.

SECTION 12: Ecological Information

GHS Classification: No classified hazards

Toxicity: All acute aquatic toxicity studies on samples of lubricant base oils show acute toxicity values greater than 100 mg/L for invertebrates, algae, and fish. These tests were carried out on water accommodated fractions and the results are consistent with the predicted aquatic toxicity of these substances based on their hydrocarbon compositions.

Persistence and Degradability: The hydrocarbons in this material are not readily biodegradable, but since they can be degraded by microorganisms, they are regarded as inherently biodegradable.

Bioaccumulative Potential: Log Kow values measured for the hydrocarbon components of this material are greater than 5.3, and therefore regarded as having the potential to bioaccumulate. In practice, metabolic processes may reduce bioconcentration.

Mobility in Soil: Volatilization to air is not expected to be a significant fate process due to the low vapor pressure of this material. In water, base oils will float and spread over the surface at a rate dependent on viscosity. There will be significant removal of hydrocarbons from the water by sediment absorption. In soil and sediment, hydrocarbon components will show low mobility with absorption to sediments being the predominant physical process. The main process is expected to be slow biodegradation of the hydrocarbon constituents in soil and sediment.

Other Adverse Effects: None anticipated.

SECTION 13: Disposal Considerations

The generator of a waste is always responsible for making proper hazardous waste determinations and needs to consider state and local requirements in addition to federal regulations. This material, if discarded as produced, would not be a federally regulated RCRA "listed" hazardous waste and is not believed to exhibit characteristics of hazardous waste. See Sections 7 and 8 for information on handling, storage and personal protection and Section 9 for physical/chemical properties. It is possible that the material as produced contains constituents which are not required to be listed in the SDS but could affect the hazardous waste determination. Additionally, use which results in chemical or physical change of this material could subject it to regulation as a hazardous waste. This material under most intended uses would become "Used Oil" due to contamination by physical or chemical impurities. Whenever possible, Recycle used oil in accordance with applicable federal and state or local regulations. Container contents should be completely used, and containers should be emptied prior to discard.

SECTION 14: Transport Information

U.S. Department of Transportation (DOT)

UN Number: Not regulated
UN Proper Shipping Name: None
Transport Hazard Class(es): None
Packing Group: None
Environmental Hazards: This product does not meet the DOT/UN/IMDG/IMO criteria of a marine pollutant
Special Precautions for User: None

Transport in Bulk according to Annex II of MARPOL 73/78 and the IBC Code: Not applicable

SECTION 15: Regulatory Information

CERCLA/SARA – Section 302: Extremely Hazardous Substances and TPQs (in pounds)

This material does not contain any chemicals subject to the reporting requirements of SARA 302 and 40 CFR 372.

CERCLA/SARA – Section 311/312 (Title III Hazard Categories)

US EPA has published a final rule aligning hazardous chemical reporting under sections 311 and 312 of the Emergency Planning and Community Right-to-Know Act (EPCRA) with OSHA HCS. See Section 2 for hazard classifications under EPCRA.

CERCLA/SARA – Section 313 and 40 CFR 372

This material does not contain any chemicals subject to the reporting requirements of SARA 313 and 40 CFR 372.

Chemical Name	Concentration	De minimis
Zinc Compound(s)	<2%	1.0%

EPA (CERCLA) Reportable Quantity (in pounds)

This material does not contain any chemicals with CERCLA Reportable Quantities.

California Proposition 65

This material does not contain any chemicals which are know to the State of California to cause cancer, birth defects, or other reproductive harm at concentrations that trigger the warning requirements of California Proposition 65.

International Inventories

All components are either listed on the US TSCA inventory or are not regulated under TSCA.

All components are either on the DSL or are exempt from DSL listing requirements.

SECTION 16: Other Information

Issue Date:	Previous Issue Date:	SDS Number	Status:
02-May-2017	31-Jul-2015	829364	FINAL

Revised Sections or Basis for Revision:

Identified Hazards (Section 2); Composition (Section 3); Format change

Legend (pursuant to NOM-018-STPS-2015):

The information within is considered correct but is not exhaustive and will be used for guidance only, which is based on the current knowledge of the substance or mixture and is applicable to the appropriate safety precautions for the product.

Guide to Abbreviations:

ACGIH = American Conference of Governmental Industrial Hygienists; CASRN = Chemical Abstracts Service Registry Number; CEILING = Ceiling Limit (15 minutes); CERCLA = The Comprehensive Environmental Response, Compensation, and Liability Act; EPA = Environmental Protection Agency; GHS = Globally Harmonized System; HPR = Hazardous Products Regulations; IARC = International Agency for Research on Cancer; INSHT = National Institute for Health and Safety at Work; IOPC = International Oil Pollution Compensation; LEL = Lower Explosive Limit; NE = Not Established; NFPA = National Fire Protection Association; NTP = National Toxicology Program; OSHA = Occupational Safety and Health Administration; PEL = Permissible Exposure Limit (OSHA); SARA = Superfund Amendments and Reauthorization Act; STEL = Short Term Exposure Limit (15 minutes); TLV = Threshold Limit Value (ACGIH); TWA = Time Weighted Average (8 hours); UEL = Upper Explosive Limit; WHMIS = Worker Hazardous Materials Information System (Canada)

Disclaimer of Expressed and implied Warranties:

The information presented in this Safety Data Sheet is based on data believed to be accurate as of the date this Safety Data Sheet was prepared. HOWEVER, NO WARRANTY OF MERCHANTABILITY, FITNESS FOR ANY PARTICULAR PURPOSE, OR ANY OTHER WARRANTY IS EXPRESSED OR IS TO BE IMPLIED REGARDING THE ACCURACY OR COMPLETENESS OF THE INFORMATION PROVIDED ABOVE, THE RESULTS TO BE OBTAINED FROM THE USE OF THIS INFORMATION OR THE PRODUCT, THE SAFETY OF THIS PRODUCT, OR THE HAZARDS RELATED TO ITS USE. No responsibility is assumed for any damage or injury resulting from abnormal use or from any failure to adhere to recommended practices. The information provided above, and the product, are furnished on the condition that the person receiving them shall make their own determination as to the suitability of the product for their particular purpose and on the condition that they assume the risk of their use. In addition, no authorization is given nor implied to practice any patented invention without a license.