

ROTTLER

H85AXY CNC

HONING MACHINE

MACHINE MAINTENANCE AND PARTS MANUAL



PARTS ORDERING

For optional equipment catalogs, please visit <https://www.rottlermfg.com/documentation.php>

For fastest service ordering parts or equipment, contact us via e-mail with the information below. For customers within the U.S., send emails to parts@rottlermfg.com, for customers outside of the U.S., use intlparts@rottlermfg.com

Have the following information on hand to expedite the ordering process:

1. Your name, business name, and contact number
2. Customer number, or your billing address if you do not have a customer number
3. Shipping address if different from the billing address
4. Machine model and serial number
5. Part number and description of the item(s) to order
6. Preferred method of shipment

For customers outside of the U.S. requiring faster service, contact your local distributor.

In some cases, you may be requested to send a photo of the part you are ordering if it is a replacement part or does not appear in our database.

If you are unsure which part you need to order, contact our service department, and ask to speak to one of our service consultants. They will assist you in determining which part(s) you require.

THERE IS A MINIMUM ORDER OF \$25.00

MANUAL SECTIONS

**INTRODUCTION
MAINTENANCE
TROUBLESHOOTING
MACHINE PARTS
SDS**

INTRODUCTION

Contents

INTRODUCTION	1-2
Description	1-3
Disclaimer	1-3
Limited Warranty	1-4
Online Documentation Access	1-5
Specifications	1-6

INTRODUCTION

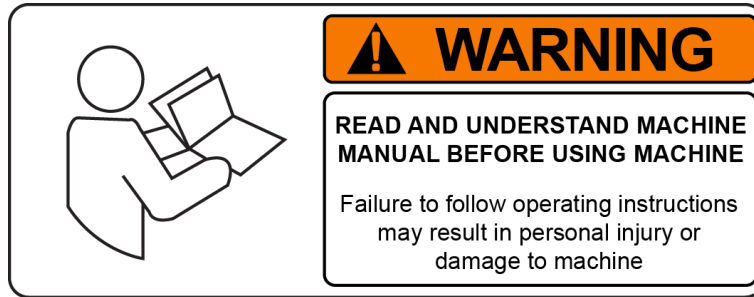

READ THE SAFETY CHAPTER BEFORE INSTALLING MACHINE. THOROUGHLY UNDERSTAND ALL SAFETY ISSUES BEFORE OPERATING MACHINE.

ATTENTION OWNER/BUSINESS MANAGER

To validate the warranty on your new Rottler machine, please be sure to sign and complete the “Installation Report” located in the Installation Chapter of this manual.

We suggest that the new user of the H85AXY read the CONTROL DEFINITIONS to get an idea how the machine operates.

The Operating Instructions chapter should be read in order to familiarize the user with the actual button pushing sequences required to carry out a job. These chapters in the manual should be considered an introduction. As the operators of the H85AXY series machines gain experience with using the different functions of the machine, complicated setups and programs will make more sense.

The rest of the manual contains information and part number reference on fixtures, cutting tools, and machine maintenance. The operator should read and become familiar with these areas as well.

Description

The model H85AXY Honing Machine is a wet, complete cylinder block and general purpose-honing machine

A Windows based touch screen panel provides easy and convenient control of the H85AXY. Block programs can be created and stored to memory for later recall, providing a quick set up for honing common blocks. All preferences such as dwell setting, cross hatch angle, and honing loads are automatically set up when a block program is selected at time of machine set-up.

The support carriage is mounted on linear rails to provide simple and easy hole-to-hole setup.

Convenient devices are provided to properly control honing operations and provide easy handling.

Fixtures are available for doing a large variety of engine types. Special fixtures and tooling for doing large industrial engine sleeves is also available.

A coolant tank is located under the main splash tank and a coolant pump is located behind the machine. A button is provided on the control panel to operate the coolant system.

Disclaimer

The H85AXY Manual (henceforth to be referred to as the “Manual”) is proprietary to Rottler Manufacturing LLC. (“Rottler Manufacturing”) and no ownership rights are hereby transferred. No part of the Manual shall be used, reproduced, translated, converted, adapted, stored in a retrieval system, communicated or transmitted by any means, for any commercial purpose, including without limitation, sale, resale, license, rental or lease, without the prior express written consent of Rottler Manufacturing.

Rottler Manufacturing does not make any representations, warranties or guarantees, express or implied, as to the accuracy or completeness of the Manual. Users must be aware that updates and amendments will be made from time to time to the Manual. It is the user’s responsibility to determine whether there have been any such updates or amendments. Neither Rottler Manufacturing nor any of its directors, officers, employees or agents shall not be liable in any manner whatsoever to any person for any loss, damage, injury, liability, cost or expense of any nature, including without limitation incidental, special, direct or consequential damages arising out of or in connection with the use of the Manual.

Rottler Manufacturing and its employees or representatives are not responsible for any information regarding final specifications of any workpiece that is created as a final product when using Rottler equipment. It is the responsibility of the end user of Rottler equipment to determine the final dimensions and finishes of the workpiece that they are working on. Any information regarding final dimensions and finishes that appears in any Rottler literature or that is expressed by anyone representing Rottler is to be regarded as general information to help with the demonstration of or for operator training of Rottler equipment.

Limited Warranty

Rottler Manufacturing Company Model H85AXY parts and equipment is warranted as to materials and workmanship. This limited warranty remains in effect for one year from the date of installation or two years from the date of the original shipment from Rottler or whichever date occurs first. This only applies if the machine is owned and operated by the original purchaser and is operated and maintained as per the instructions in the manual. A machine is warranted only if the Installation Report has been properly executed by a certified installation person and received by Rottler at the time of actual installation.

The products are warranted upon delivery to conform to their published specifications and to be free from defects in material and workmanship under normal use for a period of one year from shipment. Should a product not be as warranted, Rottler sole obligation shall be, at its option, to repair, correct or replace the product or to refund the amounts paid for the Product upon its return to a location designated by Rottler. No warranty shall extend to rapid wear Products (including tooling) or to Products which have been subject to misuse (including any use contrary to Rottler instructions), neglect, accident (including during shipment), improper handling or installation, or subject to any modification, repair or service not certified by Rottler. Rottler shall not be liable for any consequential, direct or indirect damages or for any other injury or loss. Buyer waives any right, beyond the foregoing warranty, to make a claim against Rottler. No warranty is provided for any Products not paid in full.

Merchandise cannot be returned to Rottler without prior approval. Customer must contact the Parts Department to get approval and to be issued a Return Goods Authorization number (**RGR#**). Merchandise authorized for return must be returned prepaid. If merchandise is returned with shipping charges collect, the actual amount of these charges may be deducted from any credit which may be due the customer. The **RGR #** assigned by the Parts Department should be written on the shipping label and must appear on a copy of the invoice(s) covering the original shipment. This invoice copy must be included in the box with the parts. Shipment must contain **ONLY** those items on the **RGR** as approved for return. Merchandise must be received within 10 days of the date of **RGR** or the **RGR** will be canceled. All returned merchandise may be subject to a 20% restocking fee on under \$1,000.00 amount or 10% on any items over \$1,000.00. Parts or tooling over 30 days old are considered as customer property and can only be returned with prior approval from Rottler Corporation Management.

The issuance of a **RGR DOES NOT** guarantee credit - it is only authorization for the return of the goods. Credit for return merchandise is at the sole discretion of Rottler. Credit will be issued only after inspection of returned goods.

Tools proven to be defective within the warranty period will be repaired or replaced at the factory's option.

We accept no responsibility for defects caused by external damage, wear, abuse, or misuse, nor do we accept any obligation to provide compensation for direct or indirect costs in connection with cases covered by the warranty.

Online Documentation Access

Online documentation for machines and optional equipment can be accessed at the Rottler website. To access documentation open your browser and navigate to <https://www.rottlermfg.com>.

Scroll to the bottom of the page and under the Owner Resources title click the type of documentation you want to access.

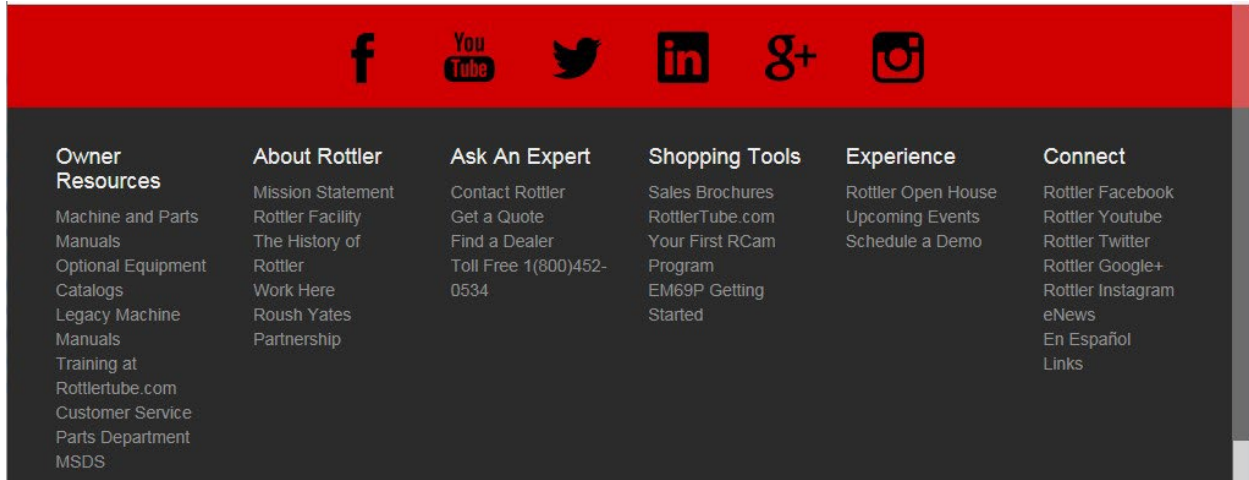

If a log in window pops up asking for user name and password fill in the blanks as shown.

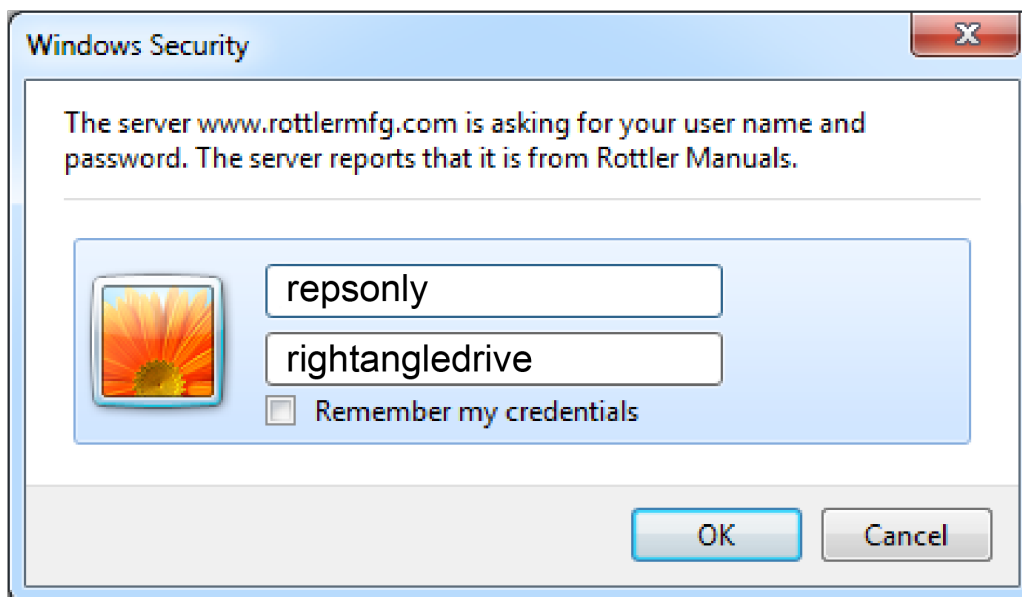

Specifications

MADE IN U.S.A.	American	Metric
Diameter Range (with Rottler Hone Heads)	1.69" - 7.38"	43mm – 187.45mm
Spindle/Hone Head Rotation Speed	1 to 400 RPM	1 - 400 RPM
Torque at Hone Head	44 ft.lbs	60NM
Spindle Motor - Torque	15 ft.lbs	20NM
Spindle Motor - Power	3.7HP	2.77 Kw
Stroker Motor - Torque	88.5in.lbs	10NM
Stroker Motor - Power	1.94HP	1.45KW
Stroke System - Acceleration	250 in/sec ²	6.35m/sec ²
Spindle Stroke - Speed	0-1500-ipm	0-38-m/min
Stroke Length - Vertical Travel (Z Axis)	19"	483mm
Length of Cylinder to be Honed	17"	432mm
Workpiece Capacity - Length	55"	1400mm
Workhead - Horizontal Travel (X Axis)	38"	965mm
Coolant Capacity	70 Gallons	265 Liters
Dimensions - Floor Space Requirements	48"D X 75"W x 86"H	1.2mD X 1.1.9mW X 2.2mH
Dimensions - Shipping	67"D X 87"W X 90"H	1.70mD X 2.21mW X 2.29mH
Weight - Shipping (excluding optional equipment)	3400 lbs	1540 kg
Electrical Requirements	208-240V, 30A, 50/60Hz, 3Ph	
Paint Color Code	RAL9002 (Grey White)	

Specifications and design subject to change without notice.

MAINTENANCE

Contents

Maintenance	6-1
Lubrication	6-1
Grease Fittings	6-1
Automatic Lubricator	6-1
Electrical Enclosure	6-1
Priming Oil Lines	6-2
Grease Fitting Locations	6-5
Honing Coolant	6-7
Standard Coolant Filter Unit	6-7
Magnetic Coolant Filter Unit	6-7
Hone Head Exploded View	6-8
Hone Head Maintenance	6-9
Replacing the Motherboard Battery	6-10
Belt Tension Adjustment	6-13
Spindle Motor Belt Adjustment	6-13
Z-Axis Motor Belt Adjustment	6-14
Ballscrew Assemblies Reference	6-15
Alignment Definitions for Angular Bearings and Belleville Washers	6-15
Bearing Alignment	6-15
Belleville Washer Alignment	6-15
Z-Axis Bearing Installation Stacking Order	6-16
Z-Axis Bearing Installation Section View	6-17
Spindle Housing Bearing Installation Stacking Order	6-18
Spindle Housing Bearing Installation Section View	6-19

Maintenance



Follow all relevant safety procedures as described in Section 3 of this manual before performing any maintenance or repair procedure.

Lubrication



Refer to the Material Safety Data Sheets on the manual CD for information on proper use and handling of lubricants mentioned in this maintenance section.

Grease Fittings

There are grease fittings on the main carriage assembly, the optional clamp arm assemblies, and the optional Turn Over Fixture. See the following images for locations of grease fittings and intervals for adding grease.

These grease fittings should be greased, using NLGI #2 White Lithium Grease.

Automatic Lubricator

The oil injection lubricator is located on the back of the main base. The oil injector lubricates the ballscrews. The automatic injection lubricator is controlled by the machine program. The controller will activate the injection lubricator at a predetermined time interval

When needed, add lubrication oil to the reservoir. Use ISO VG 68 Way Oil.

Electrical Enclosure

On a weekly basis check the door air filter and the aluminum finned heat sink and fan assembly. Replace the air filter when it becomes dirty. Blow off the heat sink and fan when it becomes covered in dust. Refer to the Machine Parts section of this manual for more details and for part number of the filter.

Priming Oil Lines

If there is ever the need to fill the oil lines that provide lubrication on the machine use the following procedure.



Do this procedure with the E-STOP engaged to prevent any accidental activation of machine functions.

- 1 Go to the Home screen.
- 2 Click the Setup Electronics tab. (2)

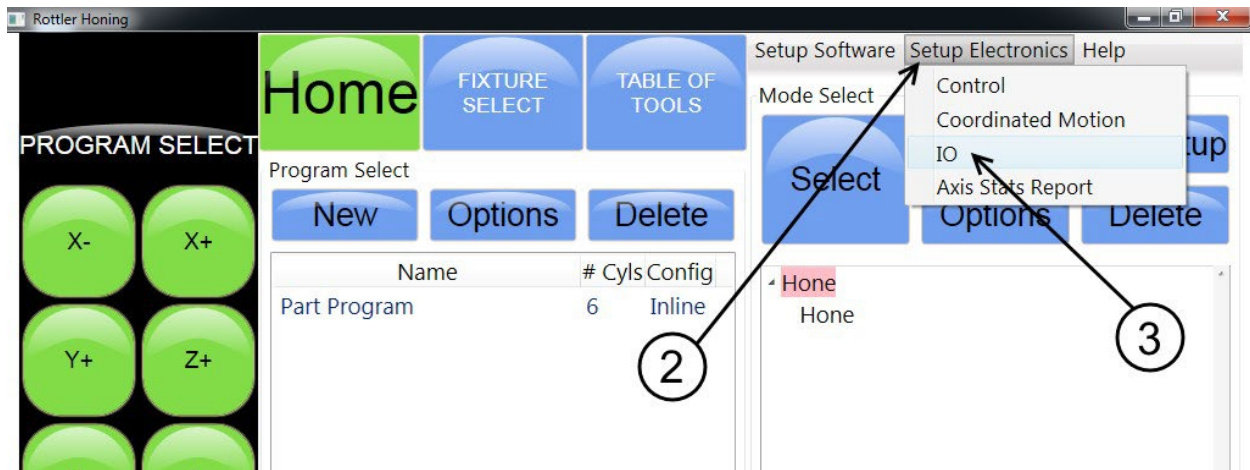

3 Select the IO tab (3) from the drop down menu. This will bring up the following screen.

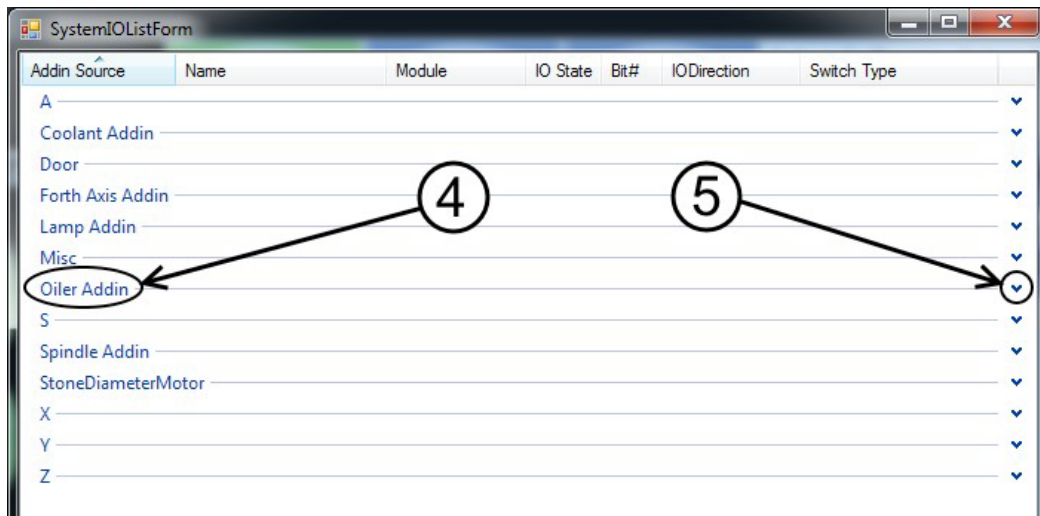

4 Go to the Oiler Addin line (4) and click the down arrow (5) to expand the section.

5 The second item on the expanded list is the control for the oiler. Click on NormallyOpen (6) and value box will appear.

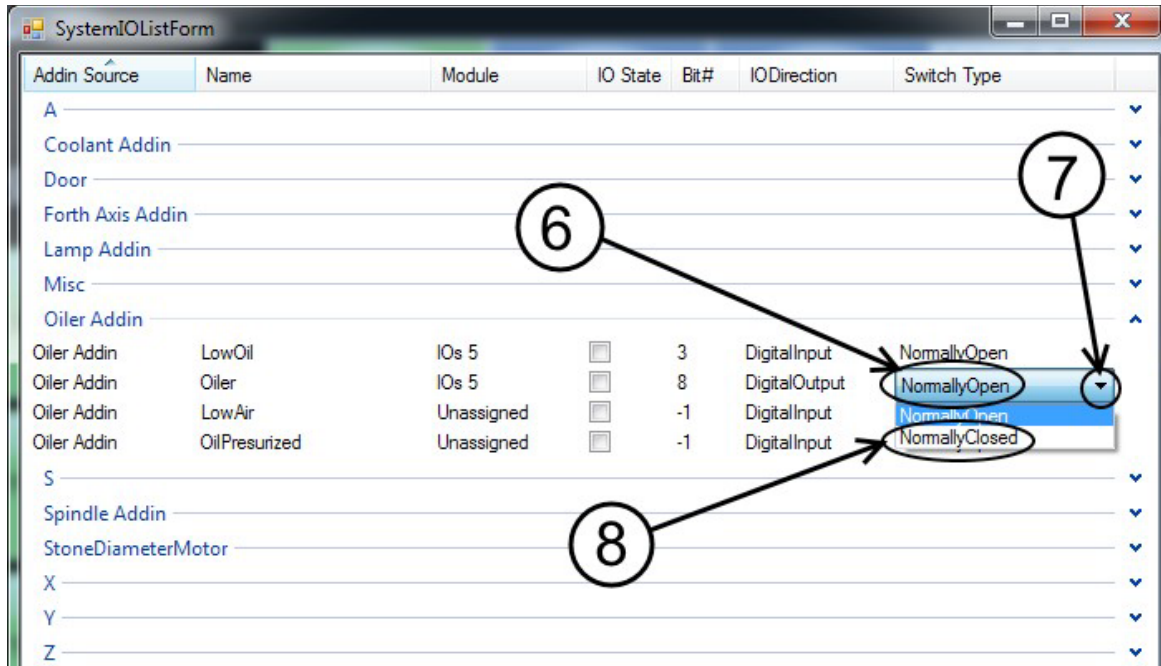

- 6 Click on the down arrow (7) and the different values available will appear.
- 7 Click on NormallyClosed (8) and it should appear on the second line in place of NormallyOpen. 8
- Click on blank section (9) of the menu to activate the new value.

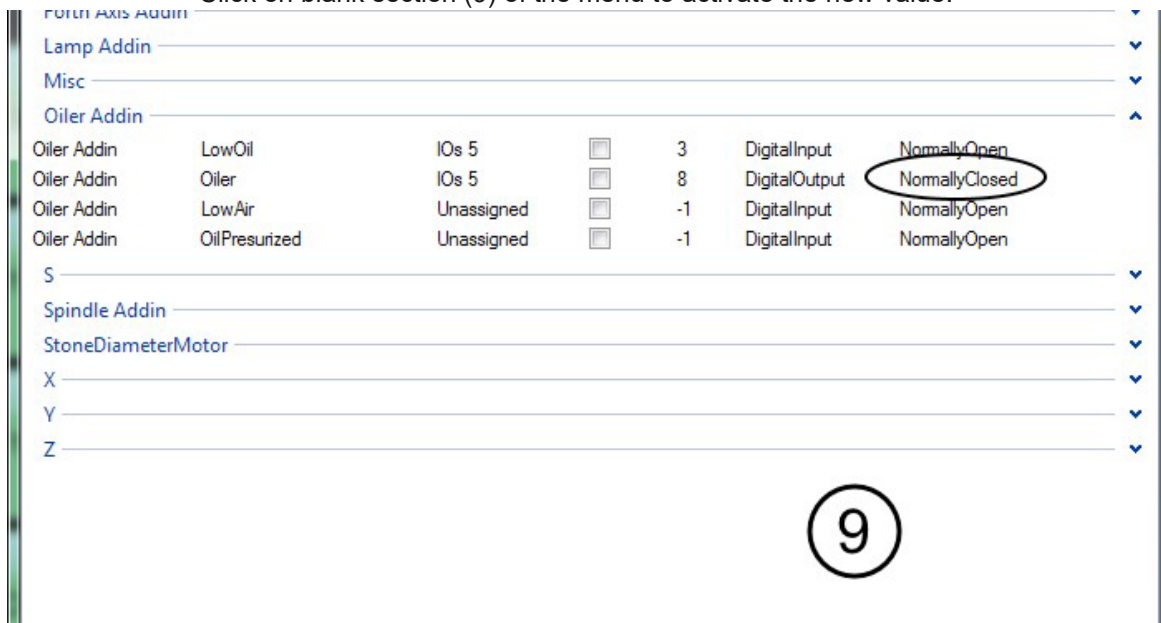

- 9 Oiler should now be running. Observe the oil lines and wait for them to become filled with oil.
- 10 Once they are filled go back to the setup window.
- 11 Click the NormallyClosed value, click the down arrow, then click NormallyOpen.

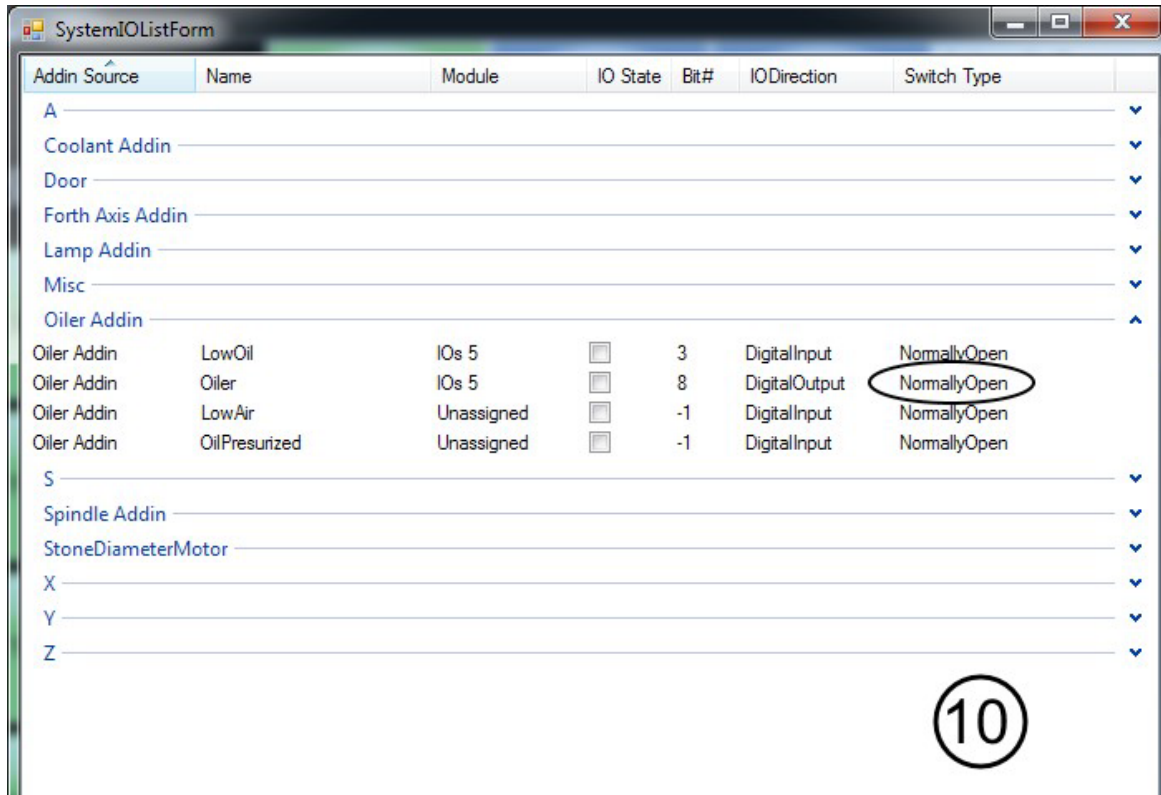

- 12 Click on a blank area (10) to set the NormallyOpen value.
- 13 Close the window.
- 14 Release the E-STOP.

Grease Fitting Locations

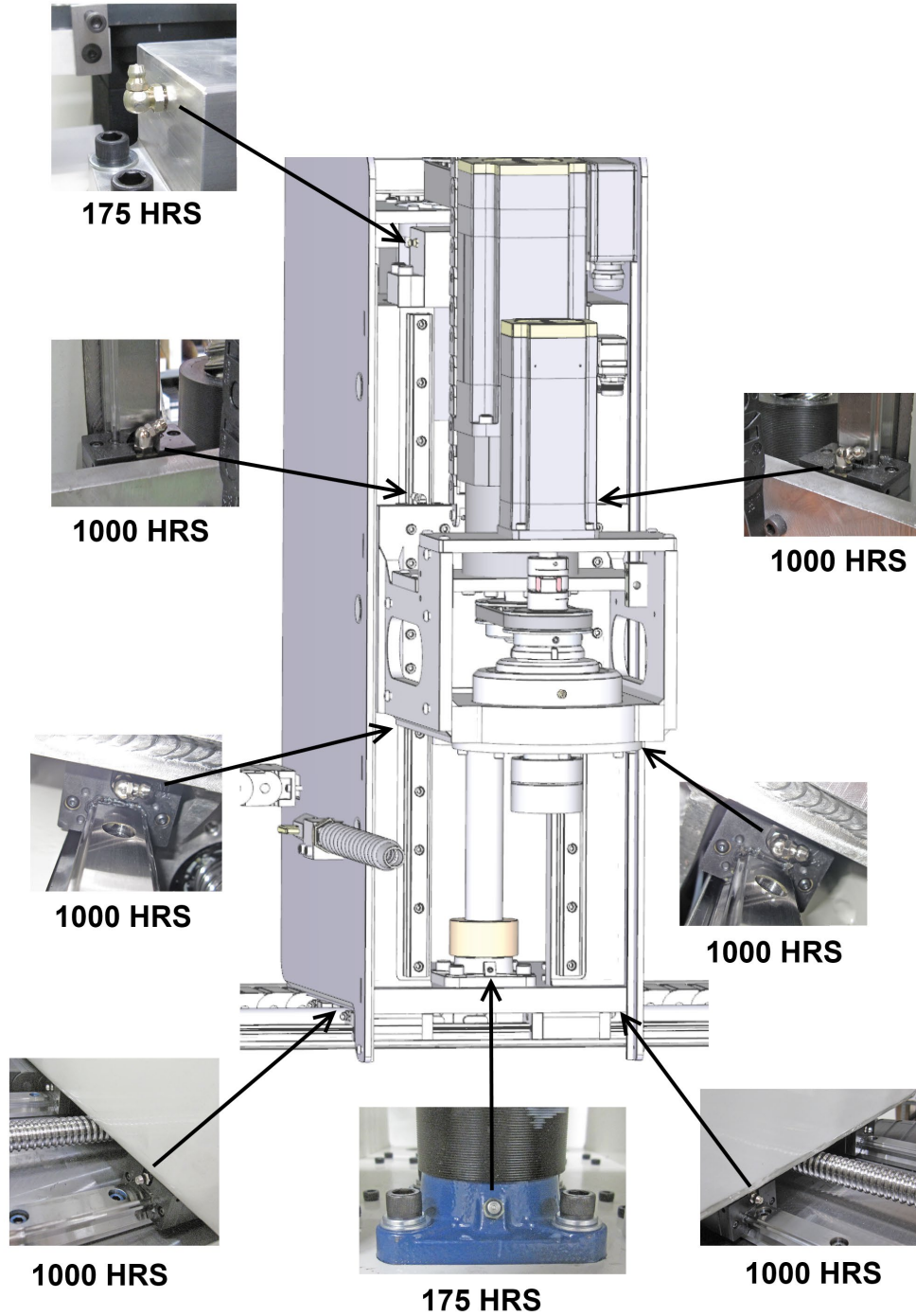

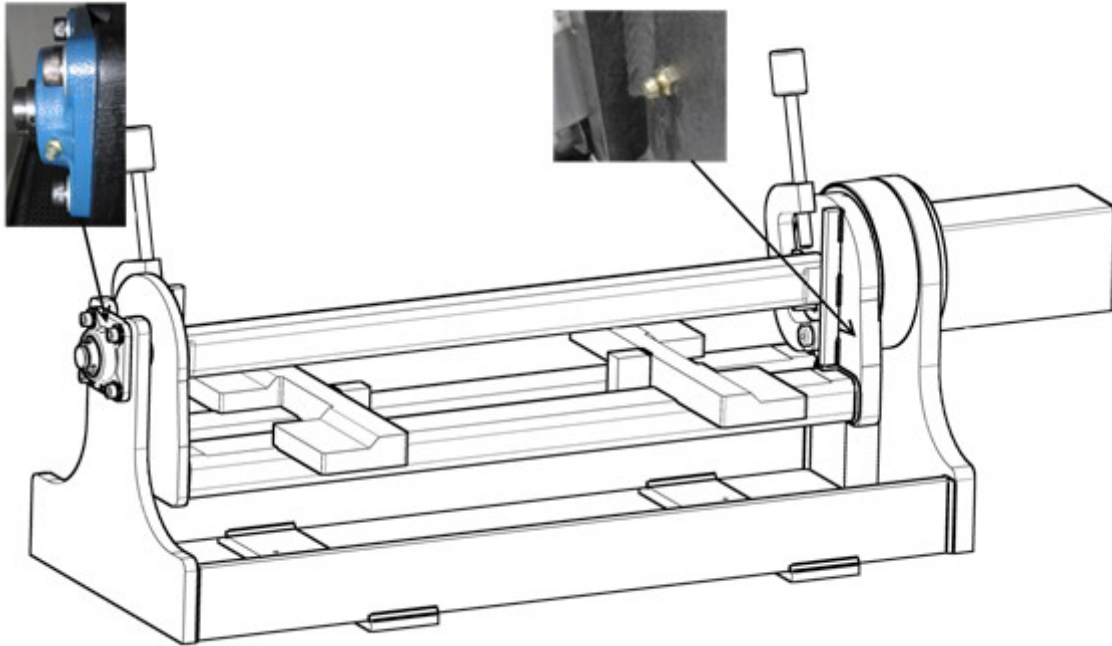

Grease should be added every 175 hours of service time.

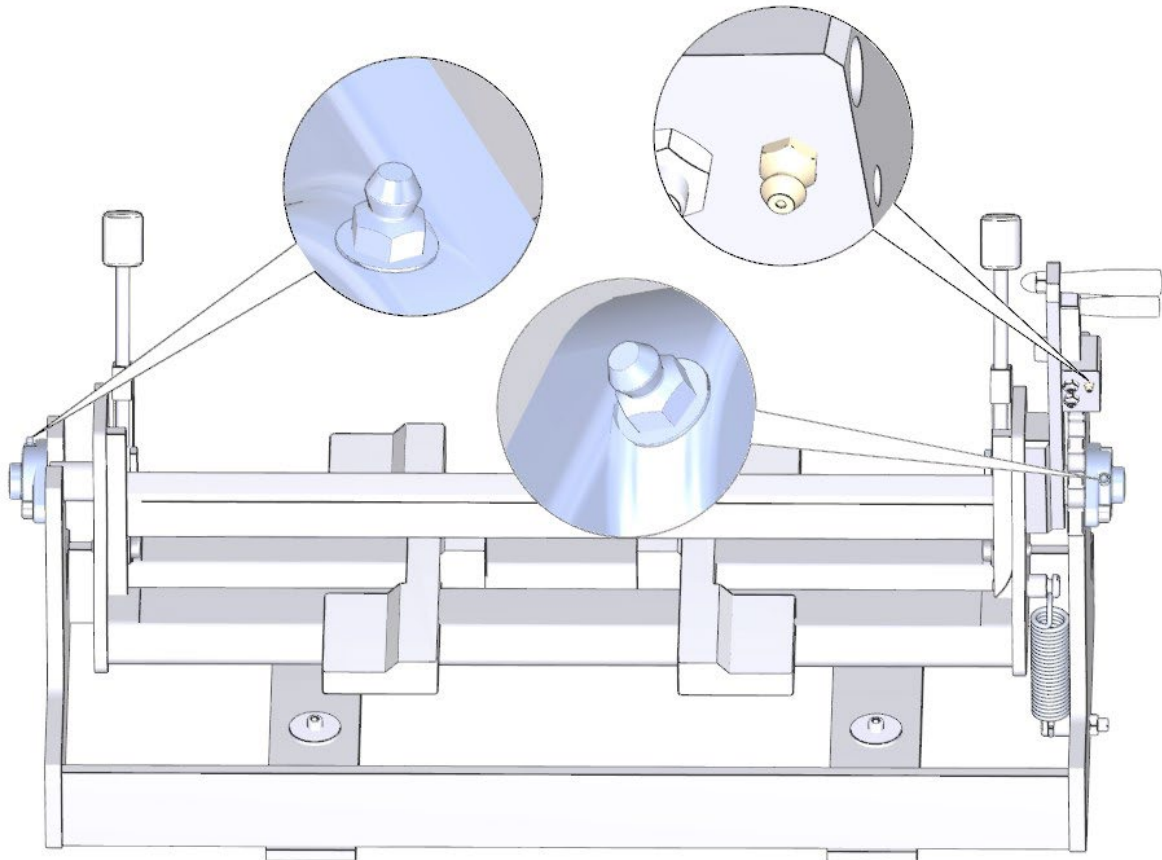

Honing Coolant

The coolant pump is located in the back of the splash tank. The coolant drains under the block fixture into a sump under the machine.

Change the honing coolant when it gets dirty. When changing coolant, completely clean tank and filter screen. Refill with Rottler 514-4-71C coolant mixed with water to a reading of 3 – 5 on the Refractometer scale. If a Refractometer is not available then a static ratio of 5% - 8% is acceptable.

Ratio of coolant to water will be approximately 1:20 or 1 gallon of coolant for each 20 gallons of water.

Standard Coolant Filter Unit

Replace filter element in filter housing as needed.

Use the supplied 514-2-42D wrench to loosen the filter bowl from the housing. Remove old filter and replace with new filter (514-2-42C). Use wrench to retighten bowl onto housing. **Do not over tighten.**

Magnetic Coolant Filter Unit

Clean unit when it becomes half full of honing particles.



Remove housing from base unit



Remove dirty magnetic element from housing



Place magnetic element on supplied stand



Using supplied scraper, remove build up from magnetic element

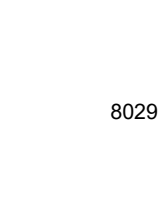

Place cleaned magnetic element back into housing and reattach to base unit

Hone Head Exploded View

(For Reference Only)



Hone Head Maintenance

This procedure should be performed every 40 hours of machine operation or weekly, whichever comes first.

1. Remove cone rod (1) from body (3) and clean threads. Lubricate threads with high pressure grease.
2. Check rubber bumper (2) for damage. Replace if damaged.
3. Clean hone head body.(3)
4. Lubricate 4 pivot screws (4) with motor oil.
5. Lubricate feed nut universal (5) with motor oil.
6. Replace cone rod (1) and rubber bumper (2) into hone head body.(3)

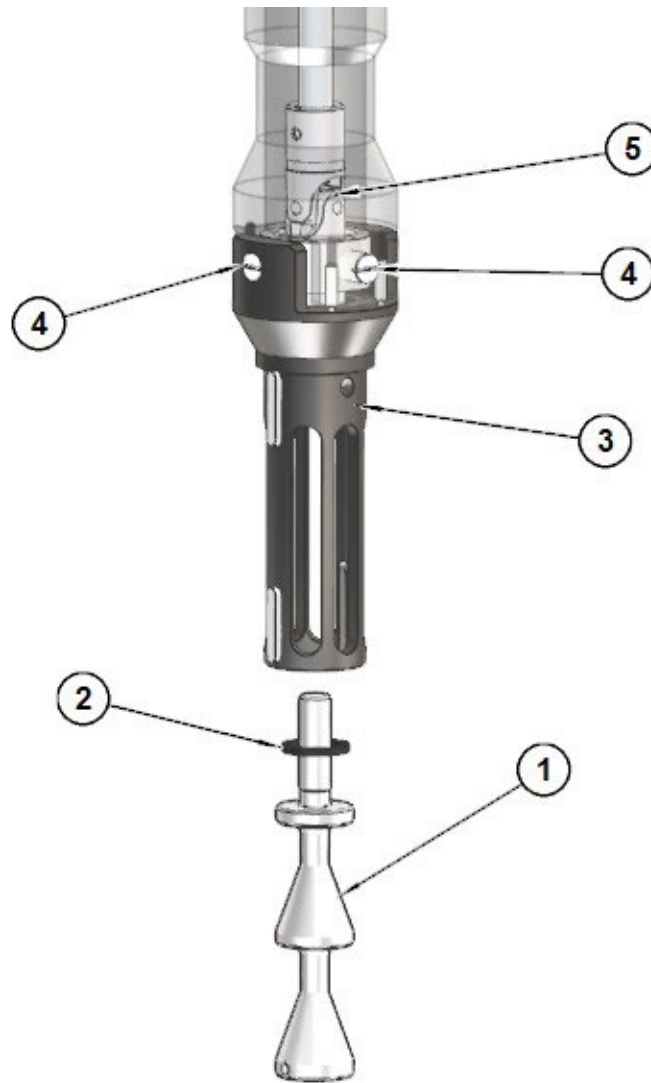

Replacing the Motherboard Battery

If computer fails to boot up and you get a CMOS error message on the screen, then the battery on the computer motherboard has failed and needs to be replaced.

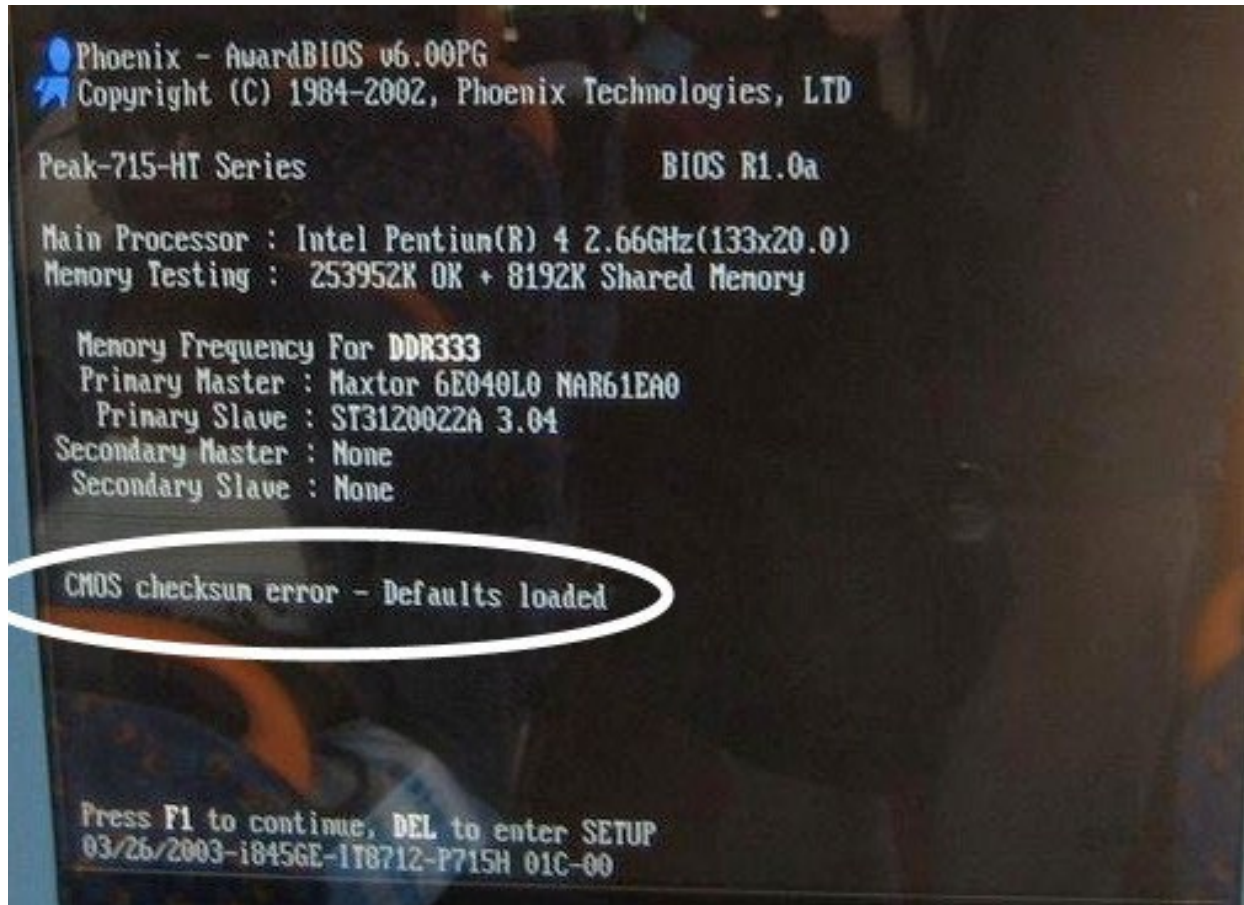

The following is the procedure for replacing the motherboard battery.

Turn off the power on the electrical enclosure and remove the enclosure cover.



Locate the computer and check to see that the power light is not on. If it is on turn off the power switch.
Note: On some machines it may be necessary to unbolt the computer from the enclosure in order to gain access to the cover screws.

Remove the 6 screws indicated by the arrows from the cover.

Remove the cover.



Locate the battery on the motherboard.



Push the battery retention clip away from the battery. When the clip is released the battery will pop up.

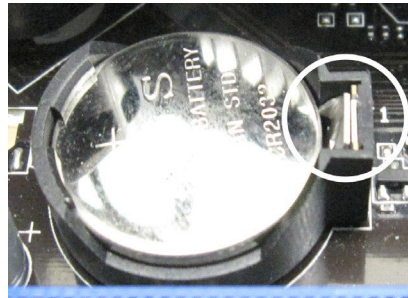

Remove the battery and place new battery in the battery holder.

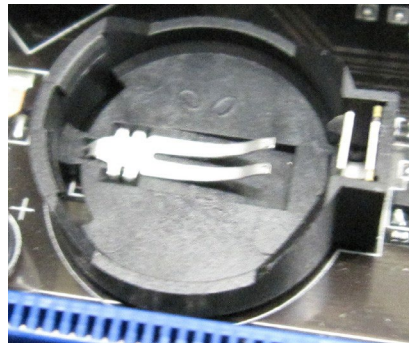

Using your finger tip push down on the battery until the retention clip is in its lock position.

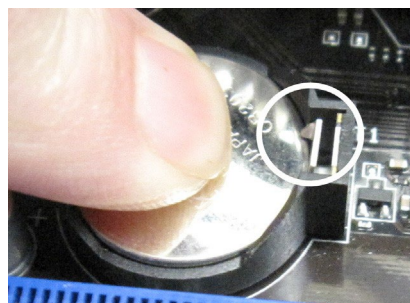

Replace computer cover and make sure that power switch on the computer is on. Replace the enclosure cover and switch power back on.

Belt Tension Adjustment

Belt Tension settings for the Z-Axis motor and the spindle drive motor are critical and must be set properly for best performance and to avoid potential damage.

Belt Tension Specifications are as follows:

- Z-Axis motor belt tension, 5 lbs of tension should produce 1/2" of belt deflection.
- Spindle drive motor belt tension, 3 lbs of tension should produce 1/4" of belt deflection.



Be sure that power is turned off before adjusting belt tension.

Adjustment on both motors is done by loosening the bolts that hold the motor in place and then tightening or loosening the belt tension adjusting bolts until the specification for that particular belt is reached.

Tighten motor hold down bolts after adjustment is completed.

Spindle Motor Belt Adjustment

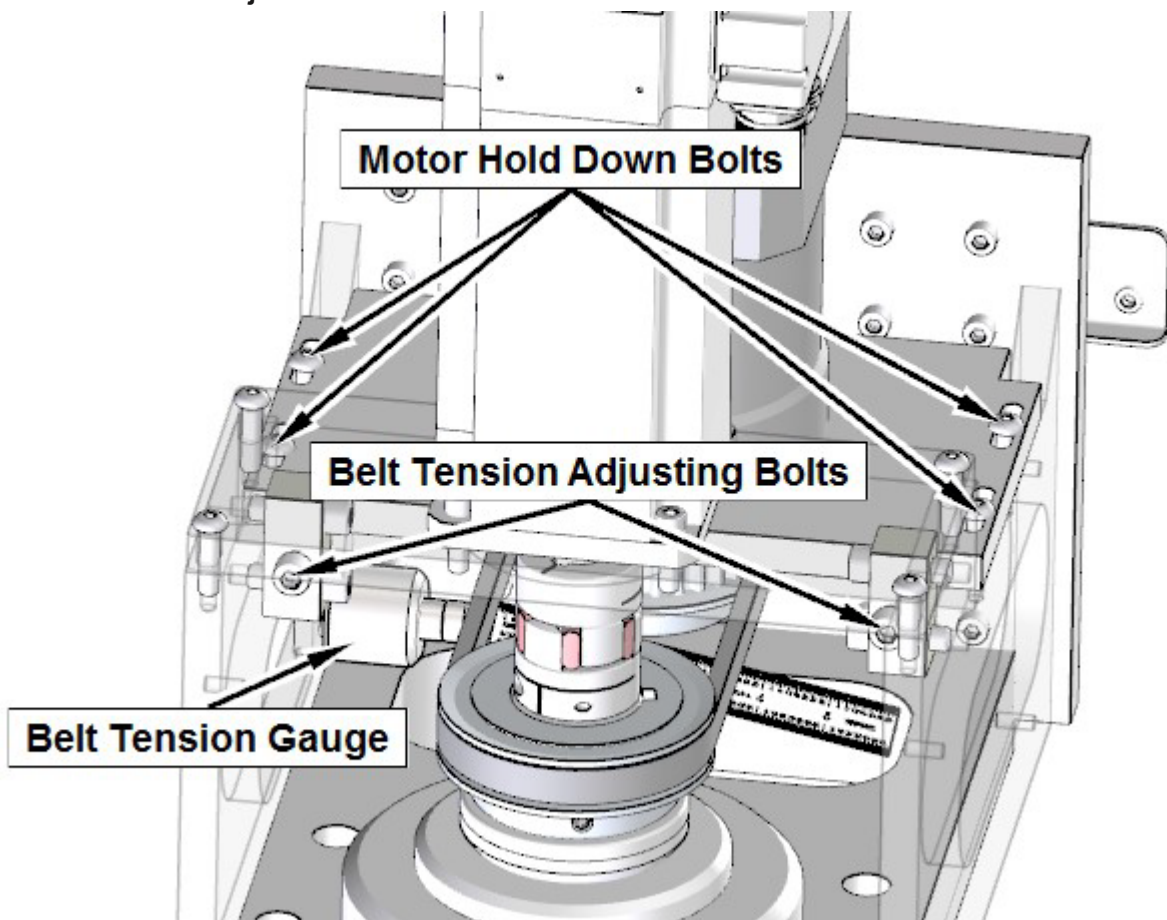

Z-Axis Motor Belt Adjustment

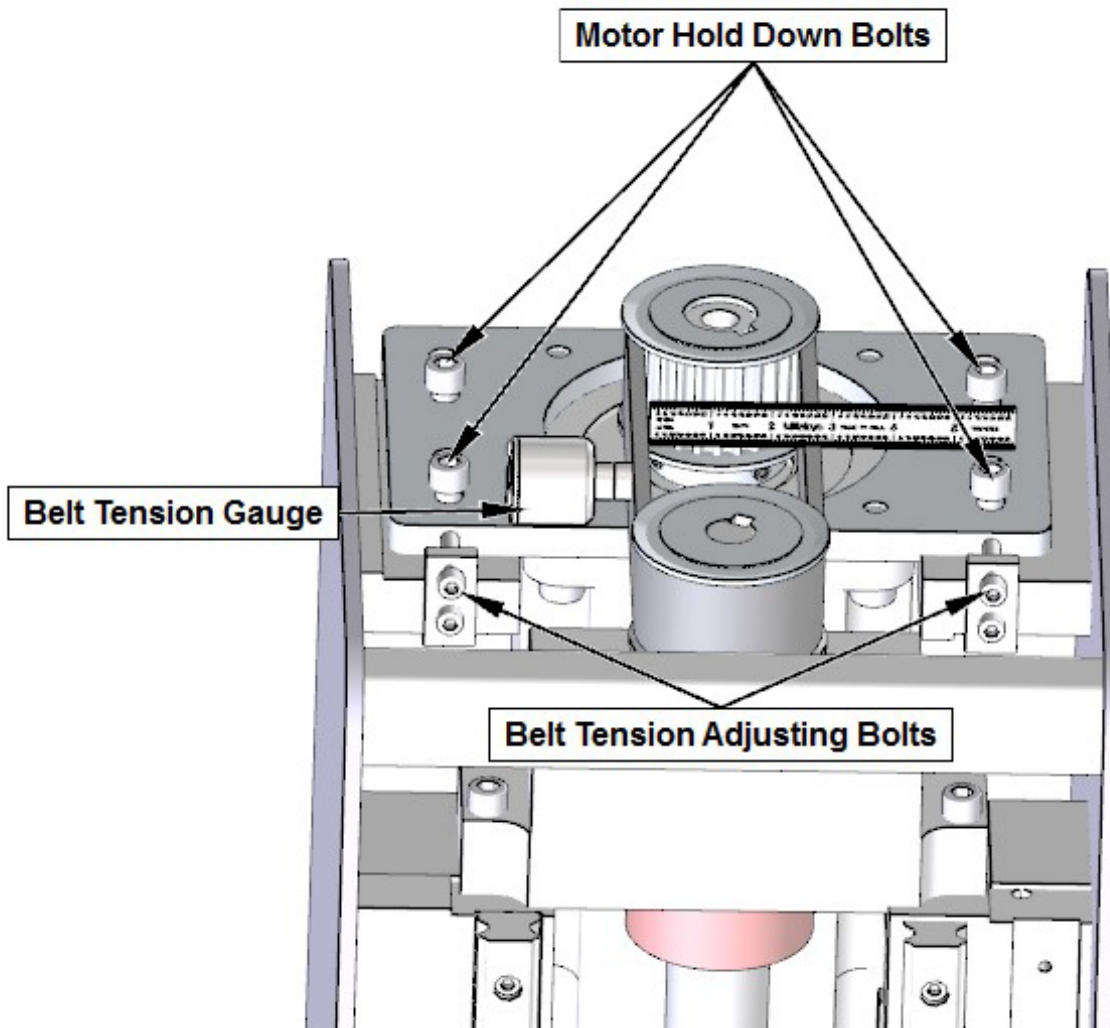

Ballscrew Assemblies Reference

Alignment Definitions for Angular Bearings and Belleville Washers

Bearing Alignment



VIEW OPEN END UP

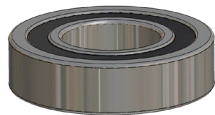

VIEW CLOSED END UP

Belleville Washer Alignment



VIEW CUP UP



VIEW CUP DOWN

Z-Axis Bearing Installation Stacking Order

Z-Axis bearings have an asymmetrical inner race design. See illustration below for proper stacking order of bearings.

2nd and 3rd bearings are install with open end up towards locknut.

1st bearing is installed closed end up towards locknut.

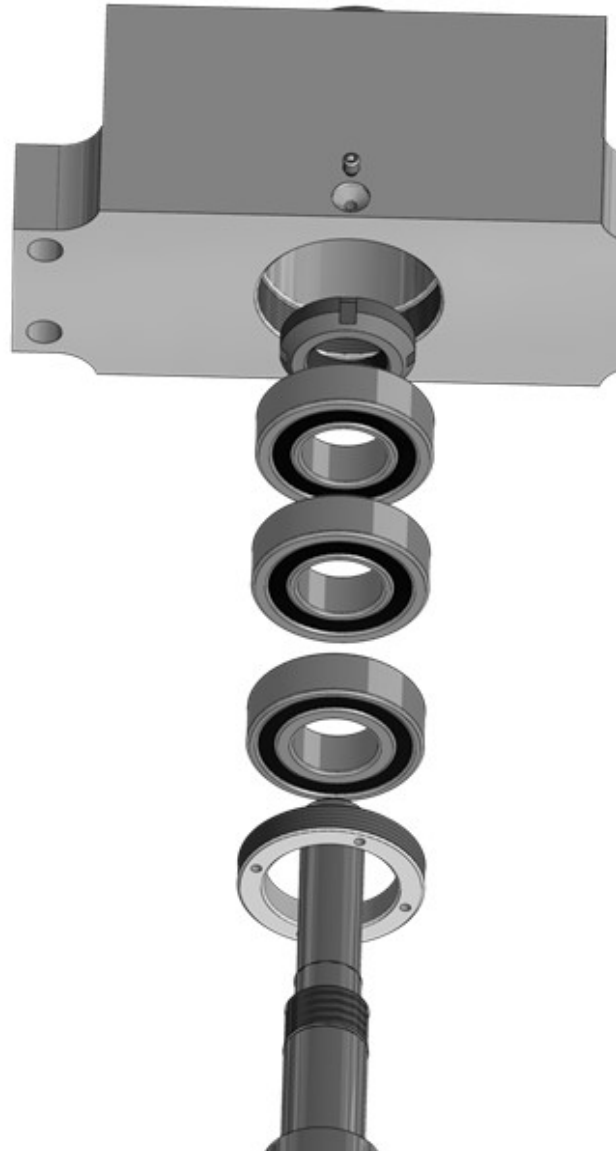

Z-Axis Bearing Installation Section View

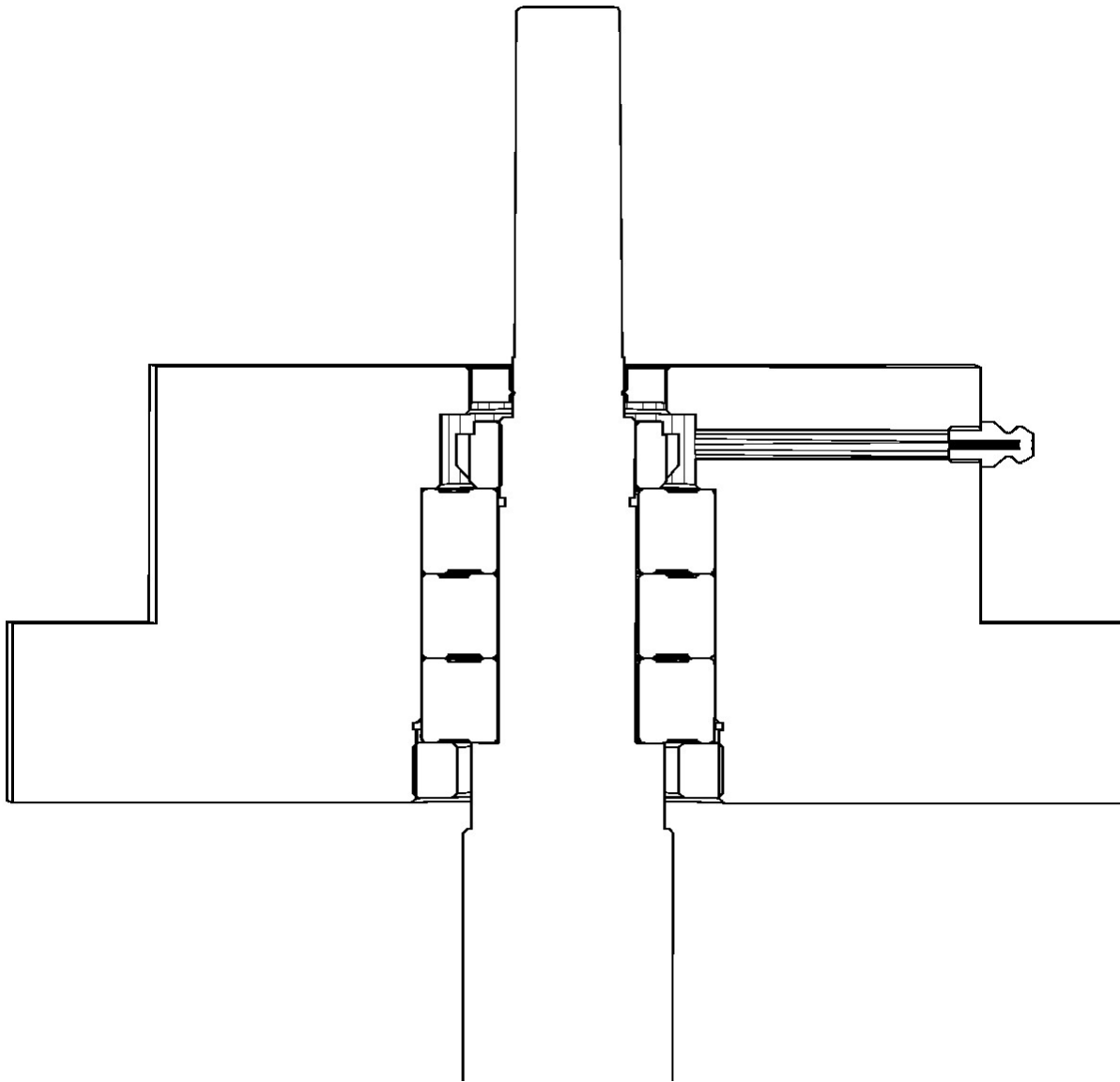

Spindle Housing Bearing Installation Stacking Order

2nd bearing is installed with closed end down towards flange.

1st bearing is installed with open end down towards flange.

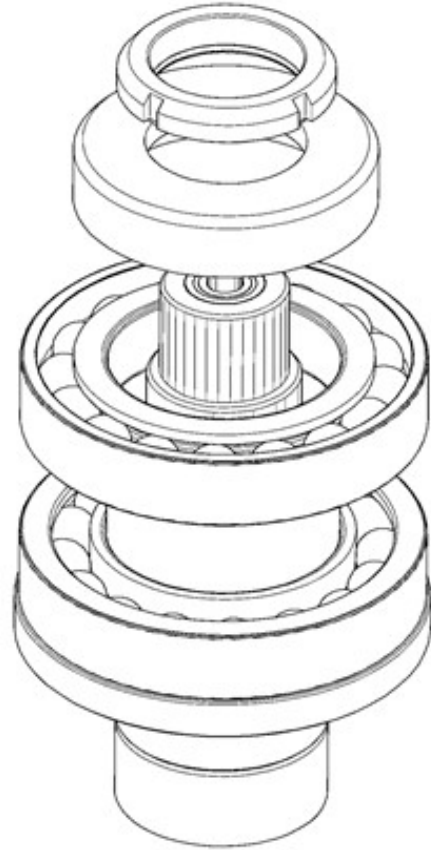

Spindle Housing Bearing Installation Section View

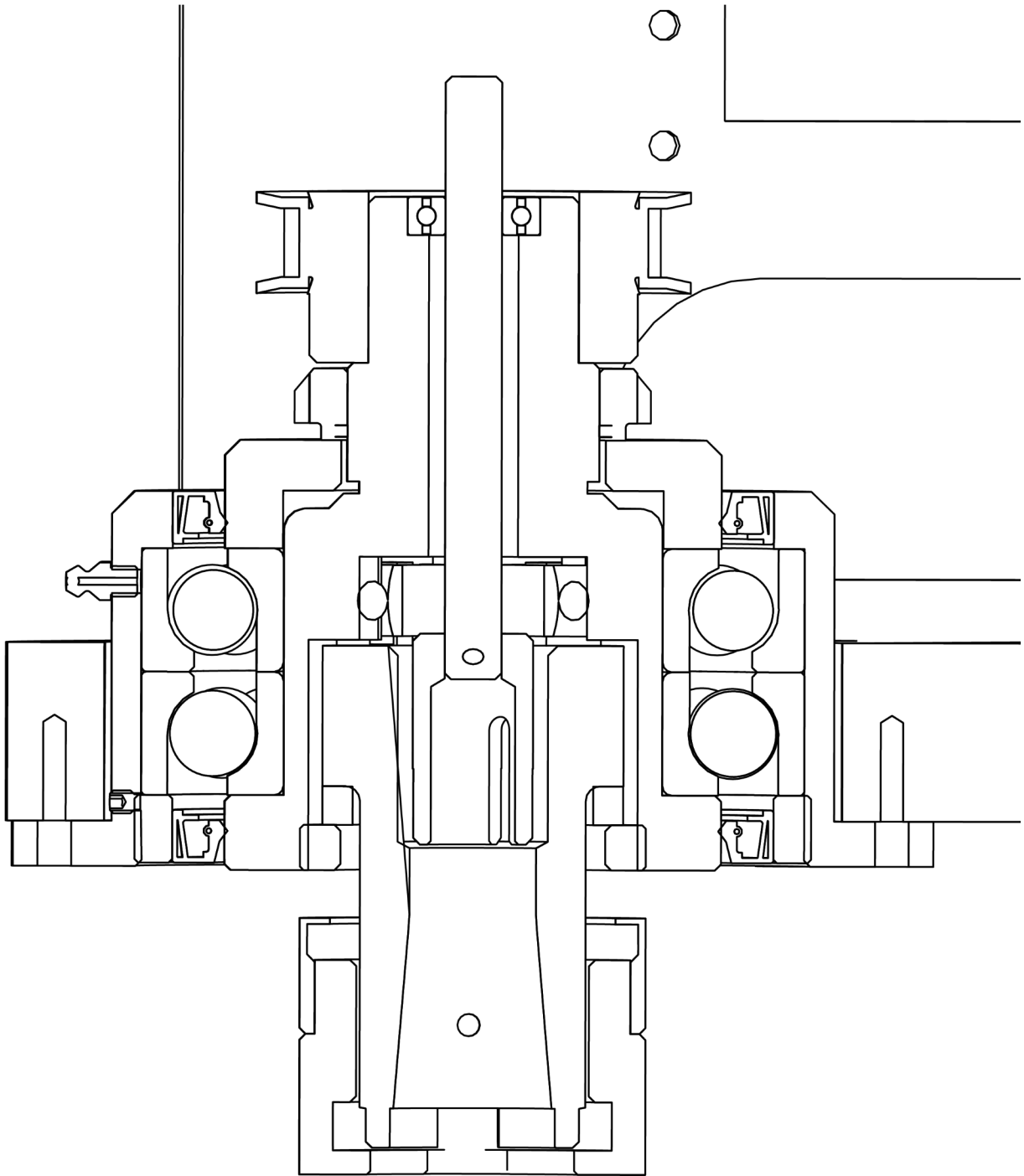

TROUBLESHOOTING

Problem:

Icon on screen does not move to area touched.

Solution:

Follow the procedure below to recalibrate the touchscreen.

1. Get to the Alignment screen.
 1. If an Elo icon is available in the tool tray at the lower right side of the desktop, click it, then click Align.
 2. Otherwise, go to the Windows Control Panel, double-click Elo Touchscreen and click the Align button on the General tab.
 1. If Windows XP and no Elo icon, click the "Switch to Classic View" button on the left
 2. If Windows 7 and no Elo icon, look for "View by: Category" text toward the upper right; click it and select "Small icons"
2. Touch and release the upper left target; the target should jump to the lower right.
3. Touch and release the lower right target; the target should jump to the upper right.
4. Touch and release the upper right target; a check screen should appear.
5. Touch and release the green check mark; the check screen should disappear.
6. The cursor should now jump to the point of touch.
7. If the Elo Control Panel is open, close it and the Windows Control Panel.

For further assistance in troubleshooting:

Please visit the service tab of our web page at Send a Service Request www.rottlermfg.com or contact the Rottler Factory Service at service@rottlermfg.com for assistance and your service request.

You may also call Rottler at 1-800-452-0534 or 1-253-872-7050

Please ensure you have the Machine Model and Serial Number available when contacting Rottler for Service

MACHINE PARTS

Contents

Machine Parts	8-1
Hone Tank and Components	8-1
Oiler and Filter Assembly	8-2
Linear Rails and X-Axis Rack	8-3
Coolant Pump Assembly	8-4
Doors	8-5
Enclosure Parts	8-6
Base Plate Assembly	8-8
Carriage Assembly	8-9
Coolant Nozzle and Ballscrew Cover	8-9
Linear Rails	8-10
Oiler Distribution Block	8-11
Z-Axis Motor Assembly	8-12
Inner Wire Track Assembly	8-13
Z-Axis Ballscrew Assembly	8-14
Lower Section	8-14
Upper Section	8-15
Outer Wire Track Assembly	8-16
Mounts	8-16
Wire Tracks	8-17
Spindle Drive Assembly	8-18
Outer Components	8-18
Inner Components	8-19
Spindle Drive Carriage Assembly	8-20
Oil Lines and Wire Track Attachments	8-20
Feed Motor Assembly	8-21
Lower Section	8-22
Spindle Drive Motor Assembly	8-23
Spindle Drive Cover	8-24
Electrical Enclosure	8-25
Door Assembly	8-25
Outside Parts	8-25
Inside Parts	8-26
Inside Components	8-27
Computer Components	8-28
Electrical Panel Assembly	8-29
Control Pendant Assembly	8-30
Outer Components	8-30
Pendant Mount	8-31
Coolant Sump Tank	8-32

Machine Parts

Hone Tank and Components

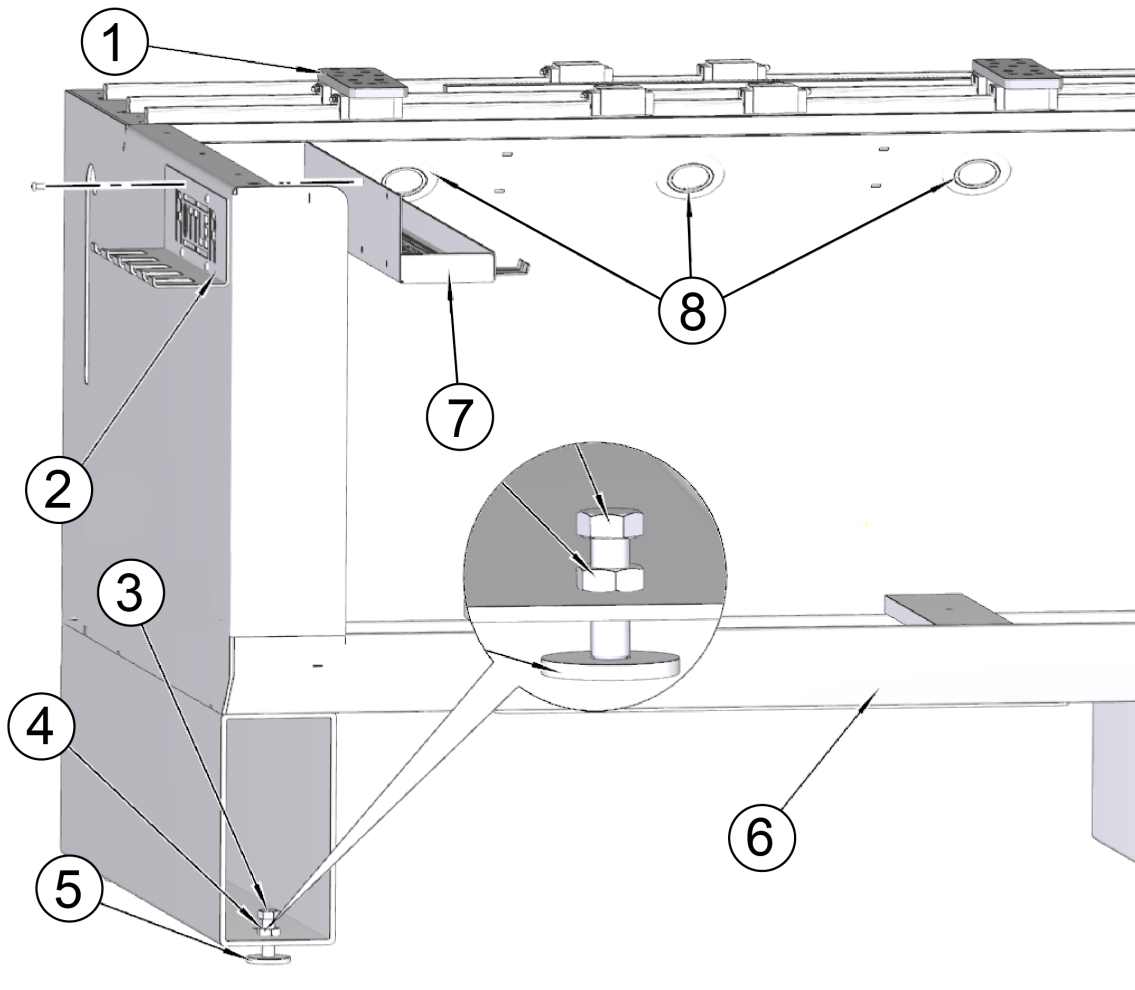

ITEM	PART #	DESCRIPTION
1	514-14-43	PLATE, CLAMP ARM MOUNT
2	514-14-45	TOOL HOLDER
3		5/8-11 X 2 HEX BOLT
4	502-1-12G	NUT, JAM 5/8-11
5	502-1-12	PAD, LEVELING
6	514-14-50	TANK
7	514-14-45A	STONE TRAY
8	6457H	LED WORKLITE

Oiler and Filter Assembly

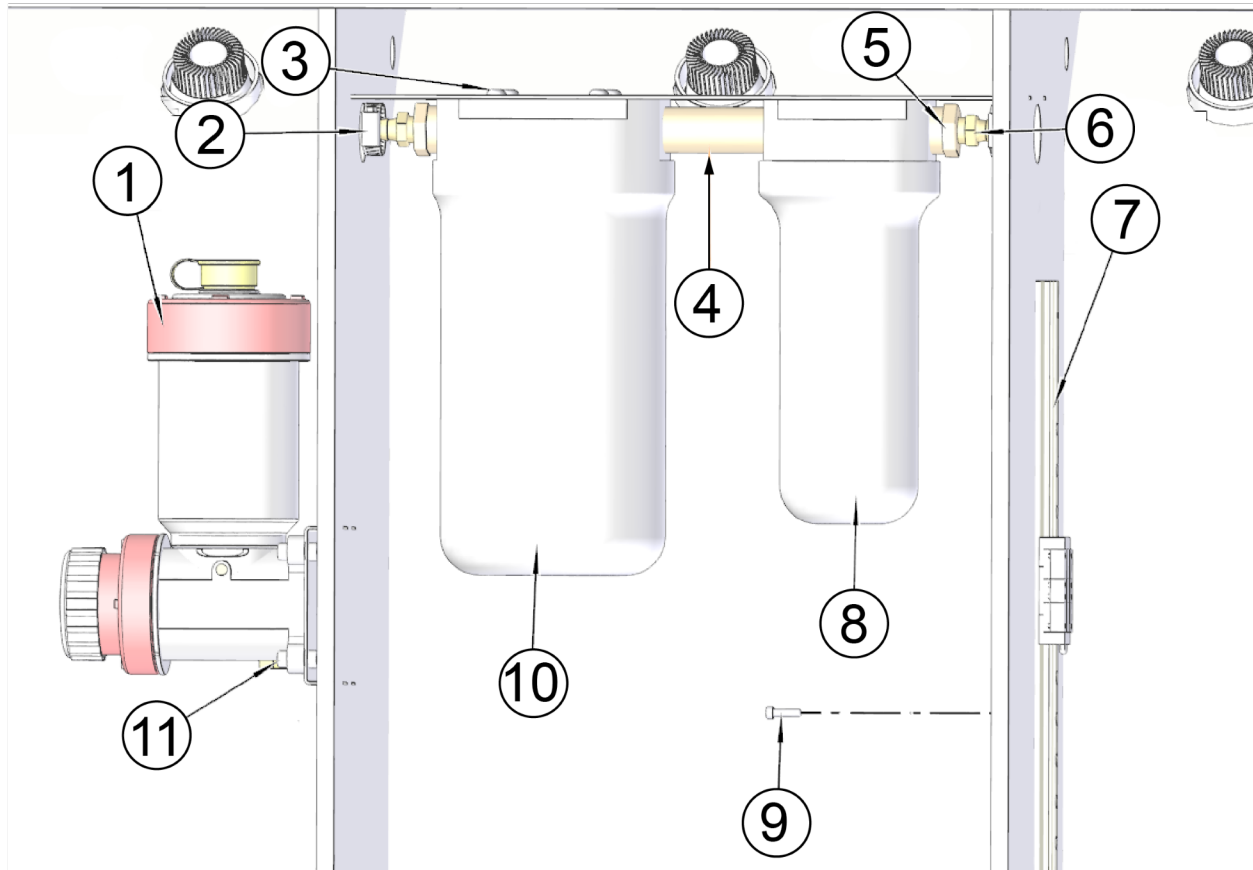

Linear Rails and X-Axis Rack

ITEM	PART #	DESCRIPTION
1	6349H	OILER, WAYS AND BALLSCREW
2	514-4-13F	CLAMP,HOSE-COOLANT HOSE (3/4 TO 1")
3	MF-93A	SOCKET BUTTON HEAD SCREW 5/16-18 X 1/2"
4	514-2-42E	NIPPLE, BRASS ADAPTER
5	514-2-42F	ADAPTOR, BRASS
6	514-2-39U	BARBED FITTING 1/2 MPT X 5/8 HOSE ID
7	11033A	LINEAR RAIL
8	514-2-42A	FILTER, MAGNETIC (OPTIONAL)
9		M5X0.8 X 20 SOCKET HEAD CAP SCREW
10	514-2-42B	HOUSING, FILTER
11	MF-22	SOCKET HEAD CAP SCREW 5/16-18 X 3/4"

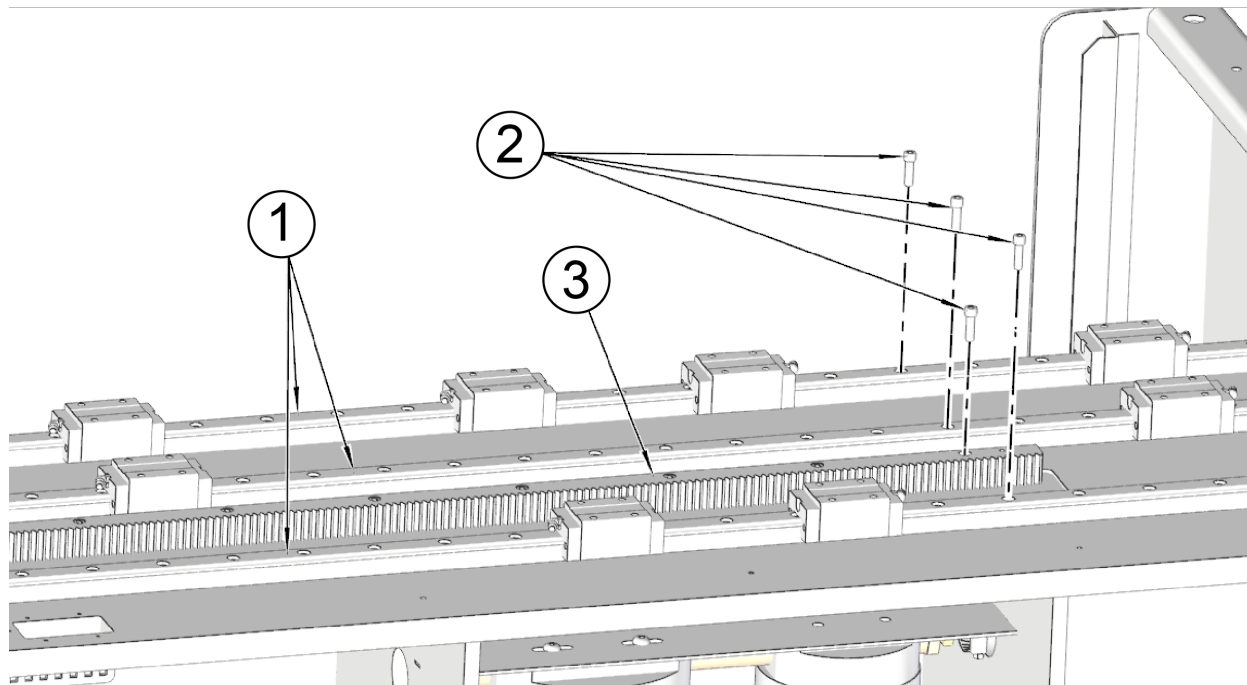

ITEM	PART #	DESCRIPTION
1	514-14-34A	LINEAR RAIL, X AXIS
2	MF-15A	1/4-20 X 7/8 SOCKET HEAD CAP SCREWS
3	514-14-41B	RACK, X AXIS

Coolant Pump Assembly

ITEM	PART #	DESCRIPTION
1	514-3-59B	HANDLE
2	514-14-47B	LEVER, COOLANT PUMP
3		1/2-13 X 5/8 BUTTON HEAD CAP SCREW
4	514-14-47A	MOUNT, COOLANT PUMP
5	MF-171	HEX JAM NUTS 1/2-13 NC
6	514-2-42G	BARB, 90 DEGREE BRASS
7	514-2-39K	PUMP-OPTIONAL FILTER ASSEMBLY

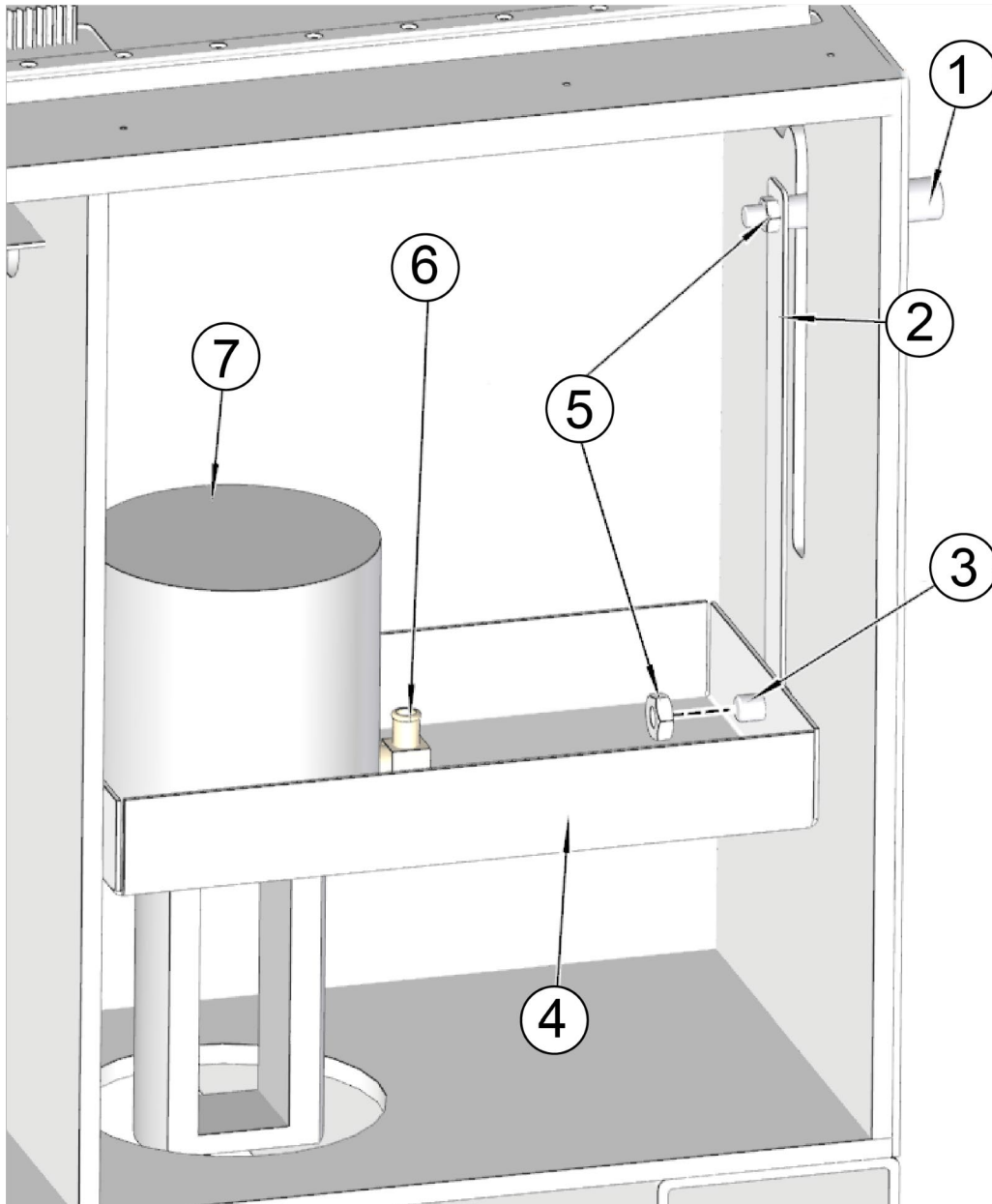

Doors

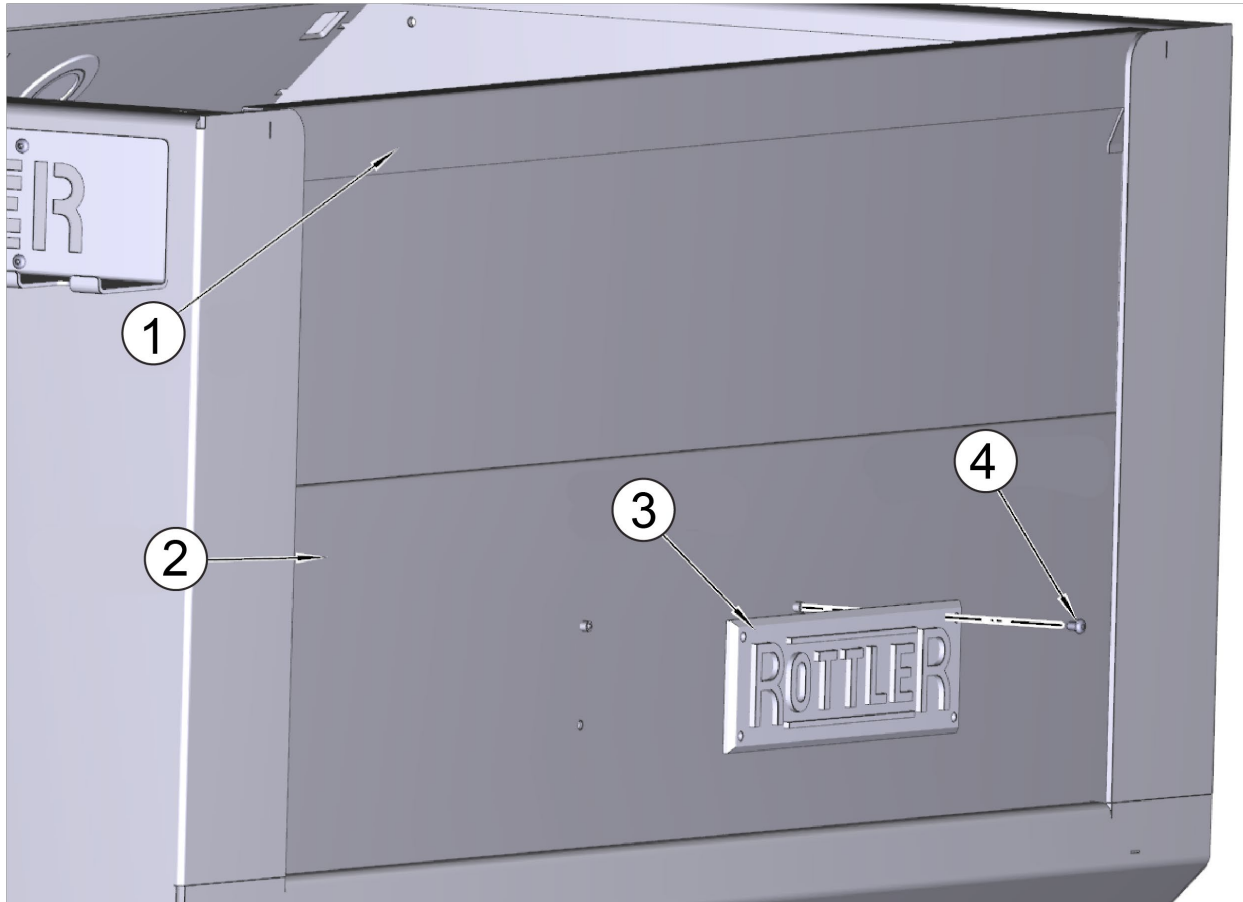

Enclosure Parts

ITEM	PART #	DESCRIPTION
1	514-13-80G	TOP DOOR, SPLASH TANK
2	514-13-81G	BOTTOM DOOR, SPLASH TANK
3	502-1-19	NAMEPLATE, ROTTLER
4	MF-248	SOCKET BUTTON HEAD SCREW 1/4-20 X 3/8"

ITEM	PART #	DESCRIPTION
1	514-14-53D	ENCLOSURE, CORNER BRACKET
2	514-14-53A	ENCLOSURE, RIGHT SIDE
3	514-13-26	SAFETY LIGHT CURTAIN (OPTIONAL)
4	514-14-53B	ENCLOSURE, LEFT SIDE
5	514-14-53E	ENCLOSURE, ACCESS PANEL
6	514-14-53C	ENCLOSURE, BACK

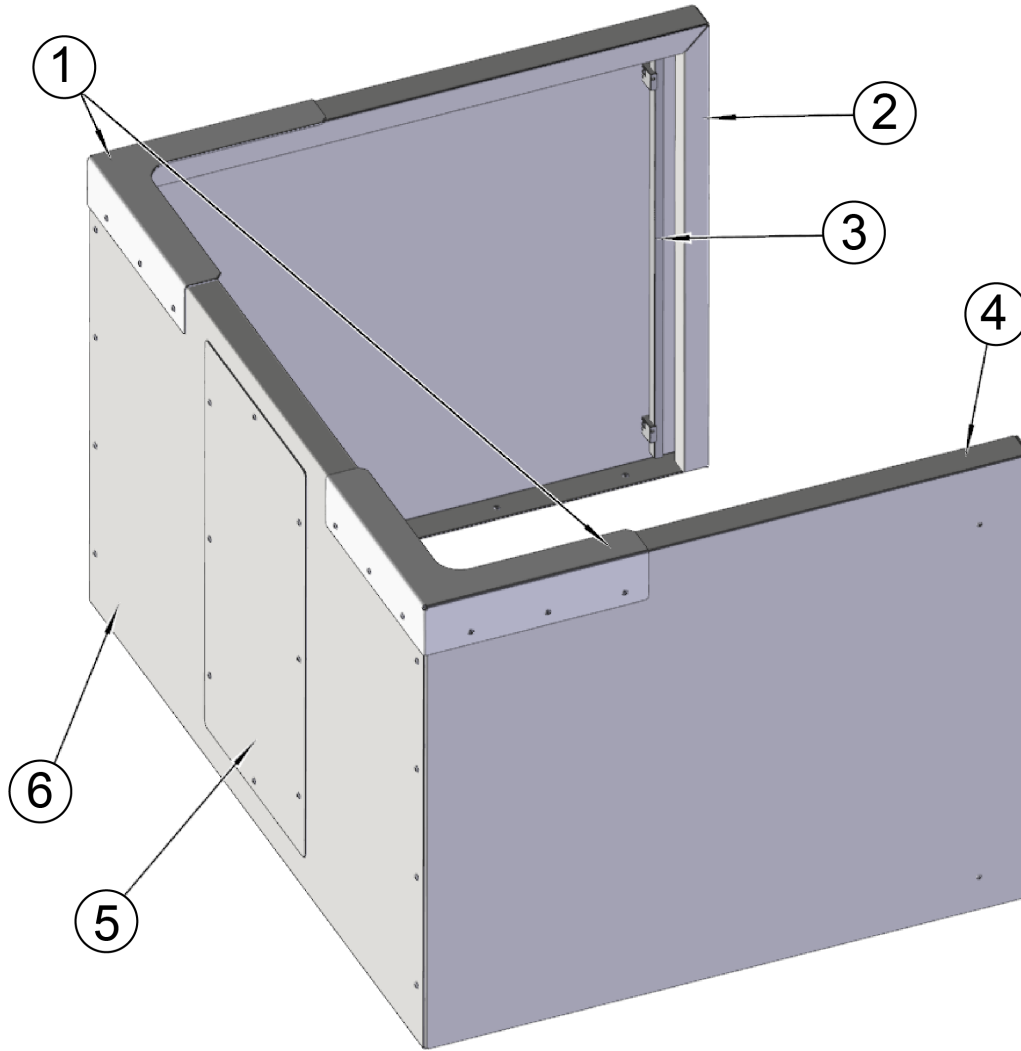

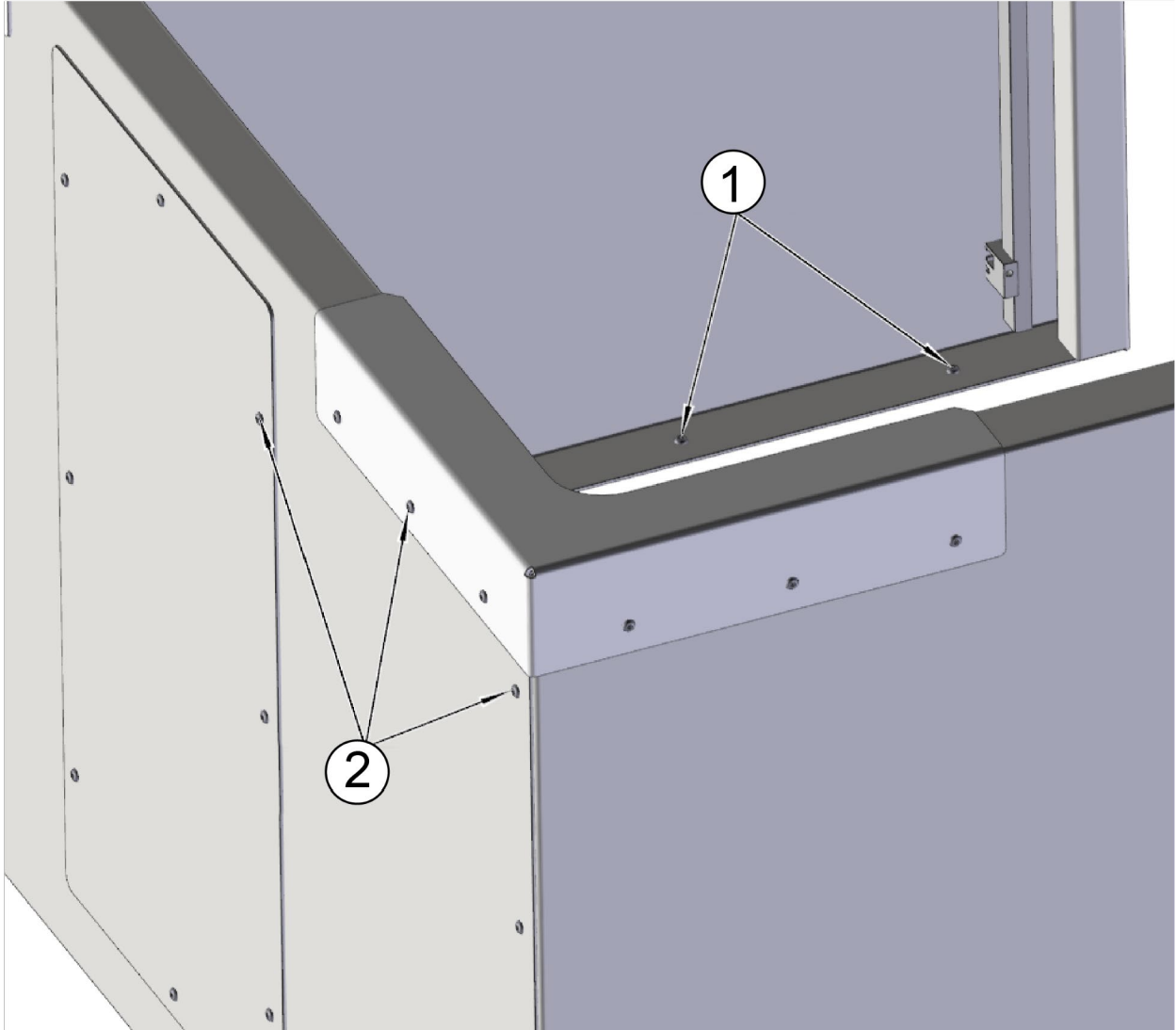

ITEM	PART #	DESCRIPTION
1	MF-90	SOCKET BUTTON HEAD SCREW 1/4-20 X 1/2"
2	MF-248	SOCKET BUTTON HEAD SCREW 1/4-20 X 3/8"

Base Plate Assembly

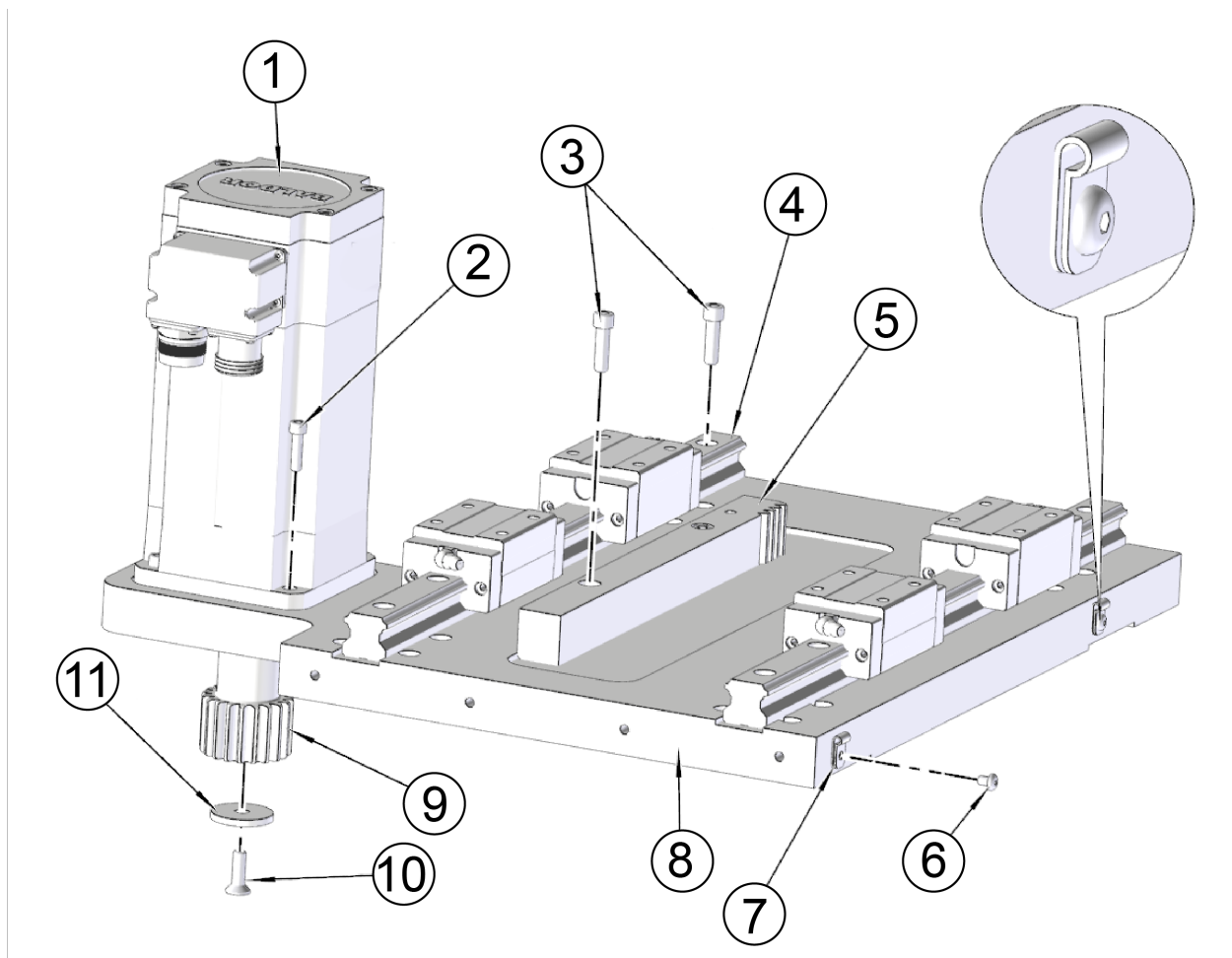

Carriage Assembly

ITEM	PART #	DESCRIPTION
1	9020N	MOTOR WITH BISS ENCODER
2	MF-6	SOCKET HEAD CAP SCREW 10-24 X 3/4"
3	MF-15A	SOCKET HEAD CAP SCREW 1/4-20 X 7/8"
4	514-14-34C	LINEAR RAIL, Y AXIS
5	514-14-41C	RACK, Y AXIS
6	MF-86	SOCKET BUTTON HEAD SCREW 8-32 X 1/4"
7	502-12-12	CLAMP, OIL HOSE (1/8)
8	514-14-42A	PLATE, Y AXIS
9	514-14-41A	PINION, RACK
10		M6 X 20 FLAT HEAD CAP SCREW
11	514-14-41D	WASHER, PINION

Coolant Nozzle and Ballscrew Cover

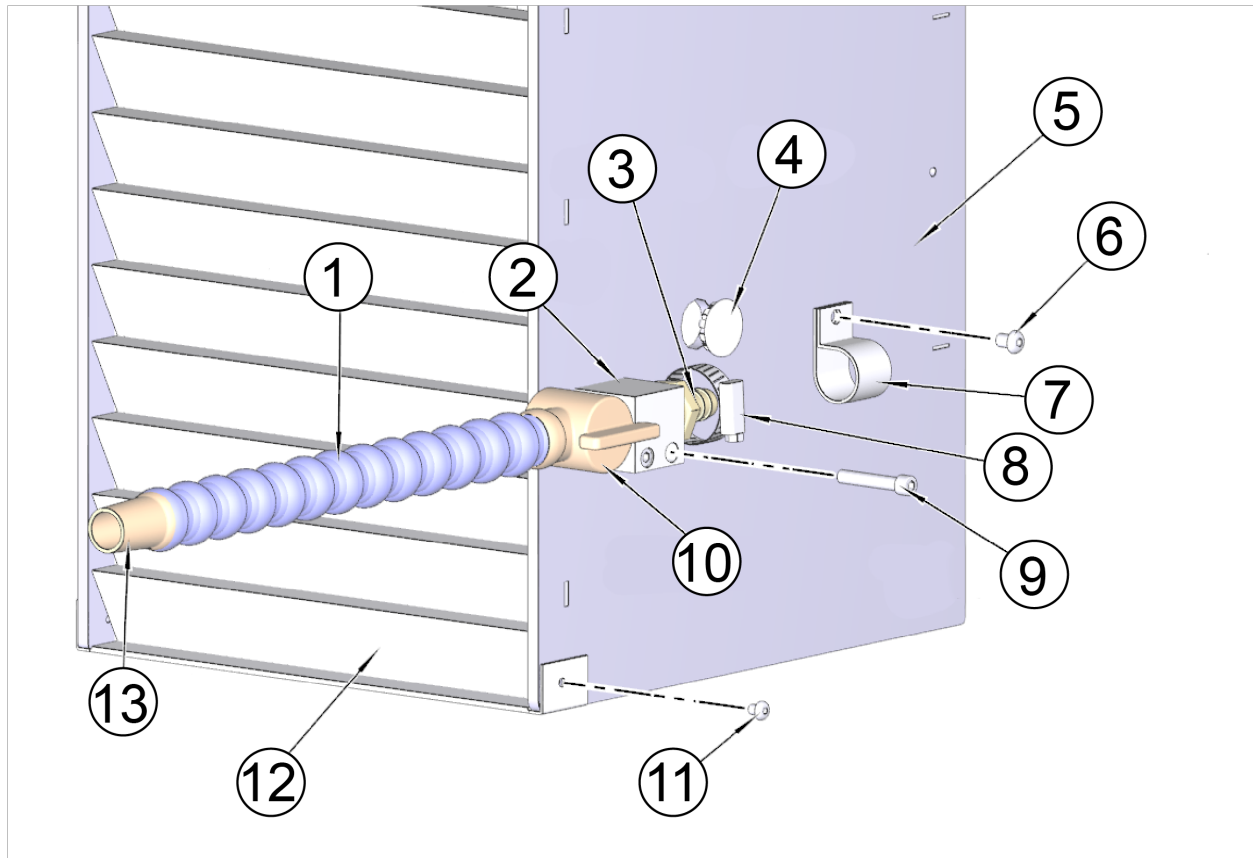

ITEM	PART #	DESCRIPTION
1	514-4-12M	HOSE, 3/4" ID (1 FOOT LONG)
2	514-14-44	MOUNT, COOLANT
3	514-2-42H	FITTING, 3/4" NPT STRAIGHT 5/8" BARBED
4	506-4	PLUG, SNAP IN HOLE - 1"
5	514-14-54	CARRIAGE
6	MF-248	SOCKET BUTTON HEAD SCREW 1/4-20 X 3/8"
7	514-14-36A	SUPPORT, COOLANT STRAIN
8	514-4-13F	CLAMP, HOSE-COOLANT HOSE (3/4 TO 1")
9	MF-17	SOCKET HEAD CAP SCREW 1/4-20 X 1 1/2"
10	514-4-12L	VALVE, 3/4" COOLANT NOZZLE
11	MF-87	SOCKET BUTTON HEAD SCREW 10-24 X 1/4"
12	514-13-19J	BELLOWS
13	514-4-12N	TIP, 3/4" COOLANT NOZZLE

Linear Rails

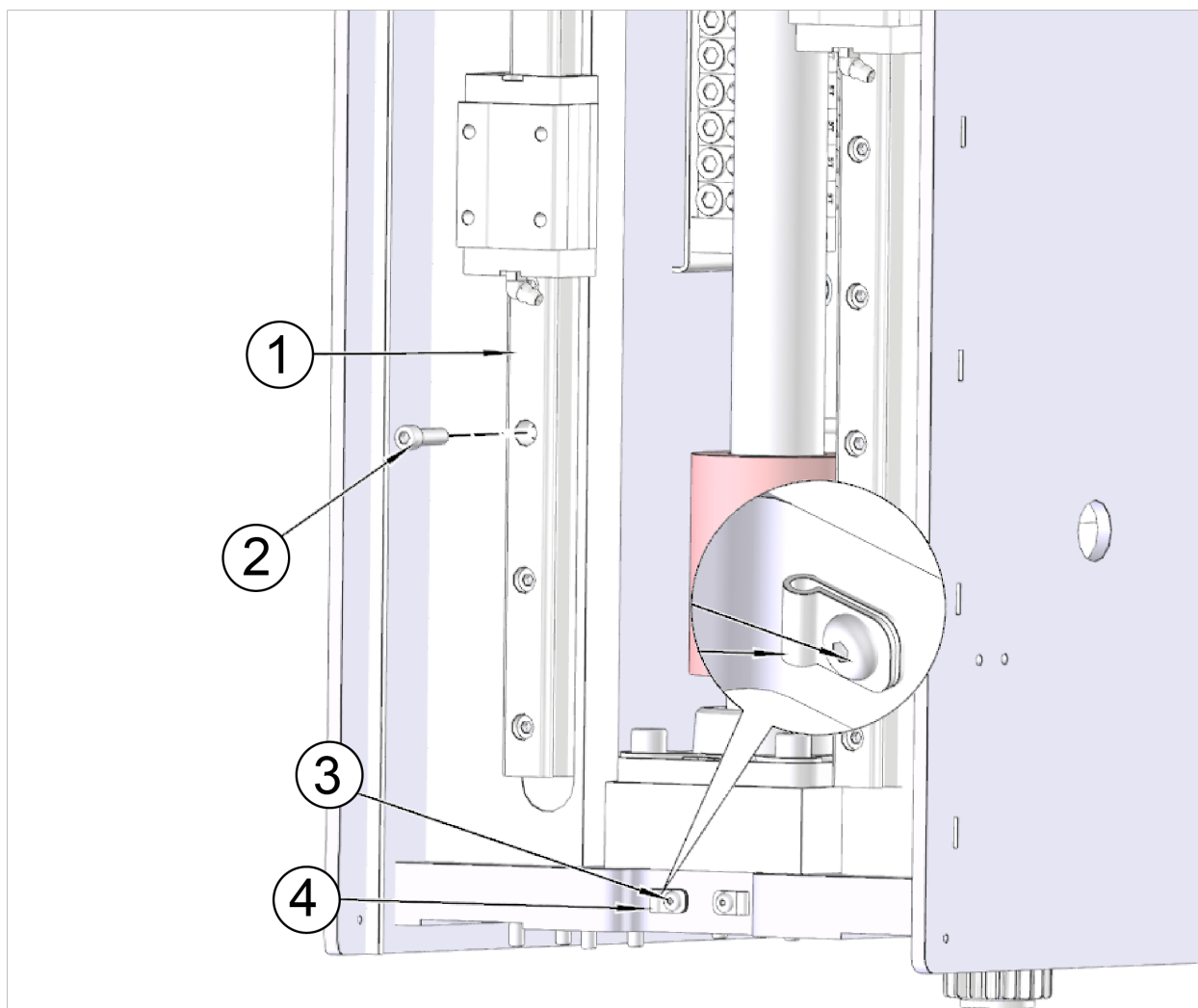

Oiler Distribution Block

ITEM	PART #	DESCRIPTION
1	514-14-34B	LINEAR RAIL, Z AXIS
2	MF-3A	SOCKET HEAD CAP SCREW 8-32 X 7/8"
3	MF-86	SOCKET BUTTON HEAD SCREW 8-32 X 1/4"
4	502-12-12	CLAMP, OIL HOSE (1/8)
ITEM	PART #	DESCRIPTION
1	6349B	FEEDER,FLO-OILER
2	514-4-18	ELBOW-90 DEGREE 1/8 POLY TO 1/8NPT
3		10-24- X 1 1/2 SOCKET HEAD CAP SCREW
4	514-4-17Y	FITTING 1/4NPT X 1/4 POLY-90 DEGREE

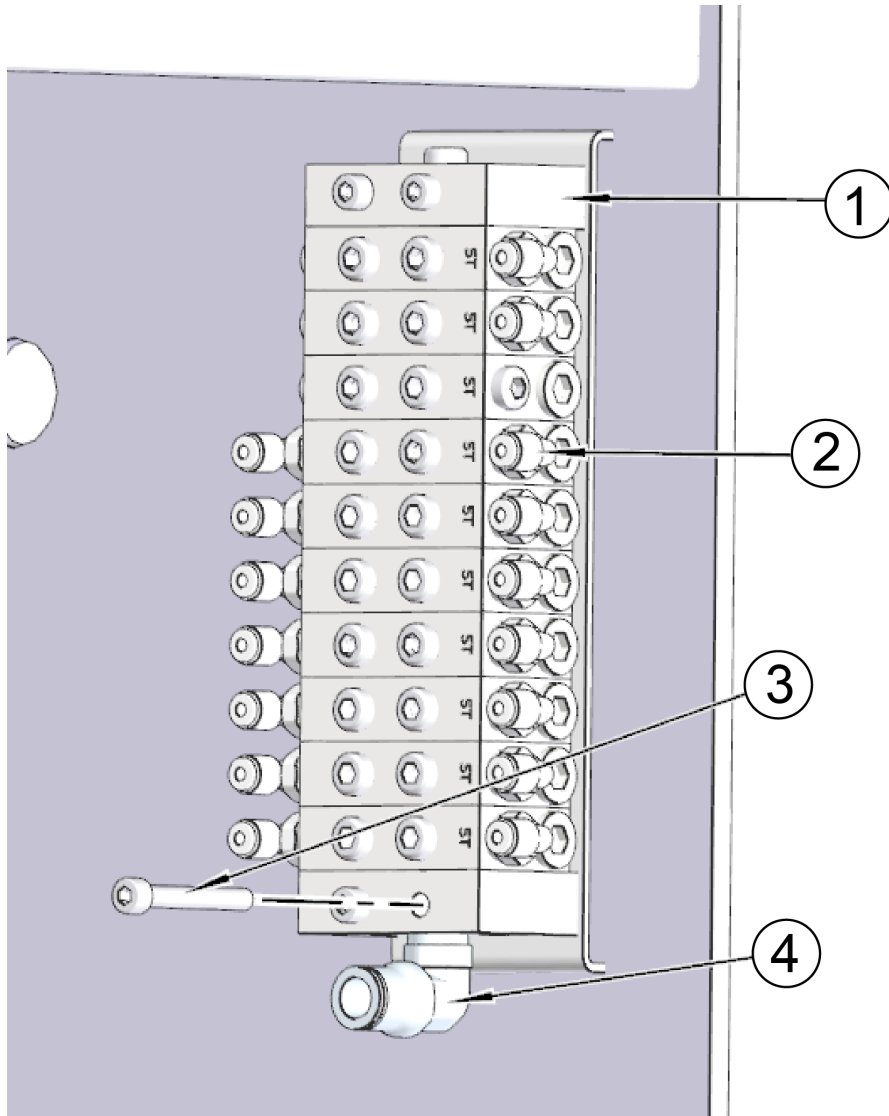

Z-Axis Motor Assembly

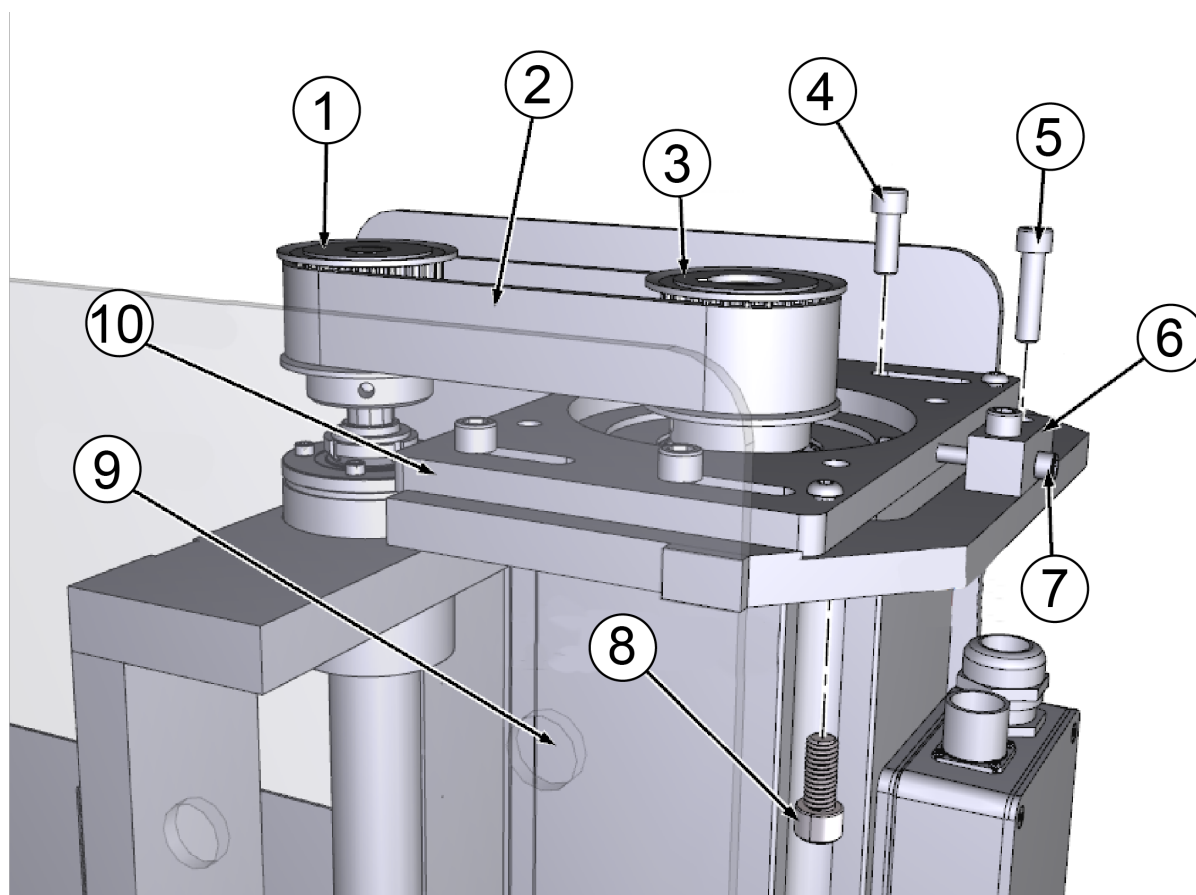

Inner Wire Track Assembly

ITEM	PART #	DESCRIPTION
1	514-13-83D	PULLEY, BALL SCREW
2	514-13-83F	BELT, TIMING Z-AXIS
3	514-13-83C	PULLEY, Z-AXIS MOTOR
4	MF-31	SOCKET HEAD CAP SCREW 3/8-16 X 1"
5	MF-24	SOCKET HEAD CAP SCREW 5/16-18 X 1 1/4"
6	514-13-11G	BRACKET, ADJUSTING
7	MF-15	SOCKET HEAD CAP SCREW 1/4-20 X 1"
8	MF-39	SOCKET HEAD CAP SCREW 7/16-14 X 1"
9	514-13-6	MOTOR, Z-AXIS
10	514-13-11D	MOUNT, MOTOR Z-AXIS
ITEM	PART #	DESCRIPTION
1	514-14-84C	CARRIER, Z-AXIS CABLE
2	MF-88	SOCKET BUTTON HEAD SCREW 10-24 X 3/8"

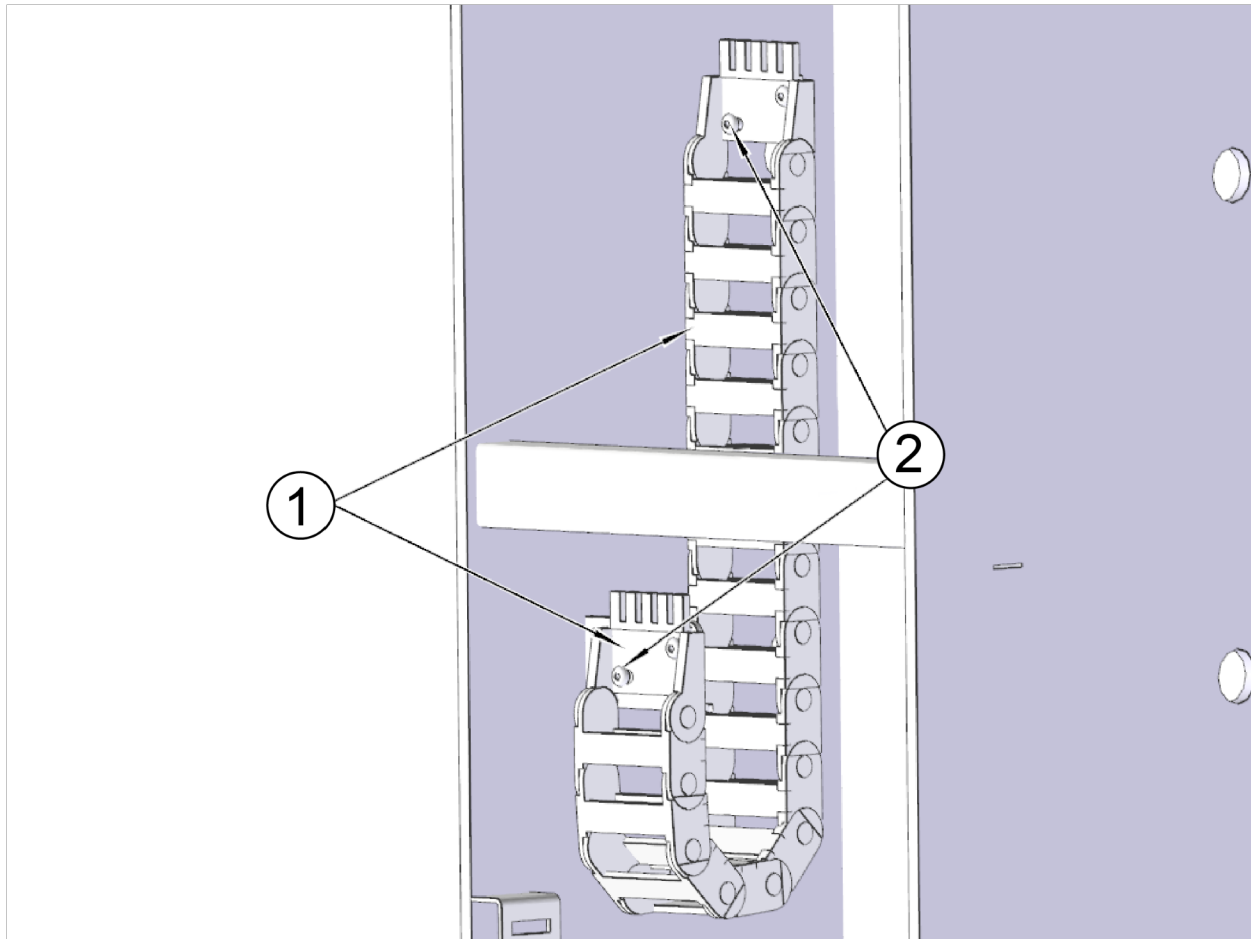

Z-Axis Ballscrew Assembly

Lower Section

ITEM	PART #	DESCRIPTION
1	514-4-17J	CONNECTOR, MALE - 1/8" OD TO 10-32
2	514-13-60B	BALLSCREW NUT, Z AXIS
3	514-13-60A	BALLSCREW, Z AXIS
4	514-14-56B	BUMPER, LOWER Z AXIS
5	MF-31	SOCKET HEAD CAP SCREW 3/8-16 X 1"
6	514-13-60J	FLANGED, SQUARE BEARING

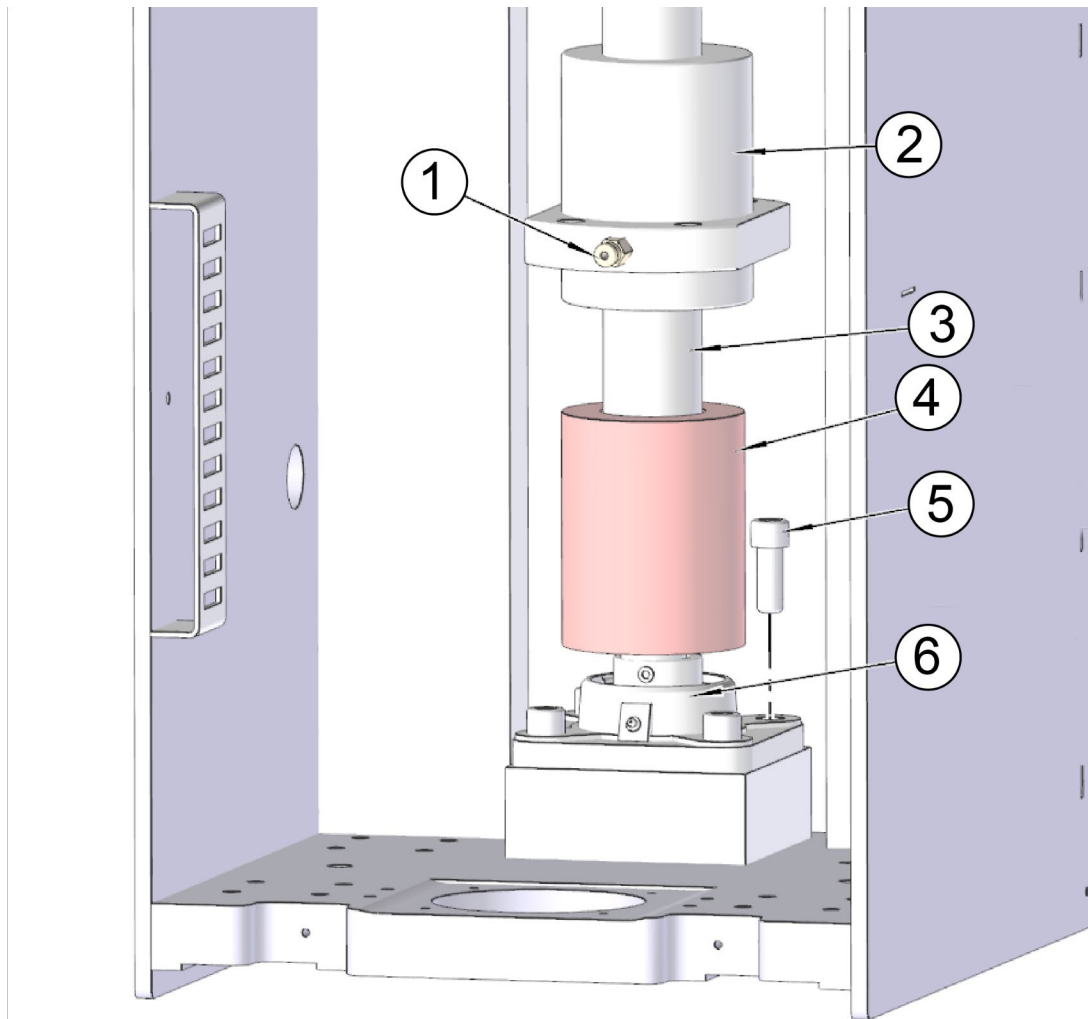

Upper Section

ITEM	PART #	DESCRIPTION
1	504-34-54	LOCKNUT BEARING
2		10-24 X 1 3/8 SOCKET HEAD CAP SCREW
3	514-14-85	BEARING, FACE MOUNT BALLSCREW
4	514-13-60P	BALLSCREW, Z AXIS
5	514-13-60K	Z AXIS LOWER BUMPER

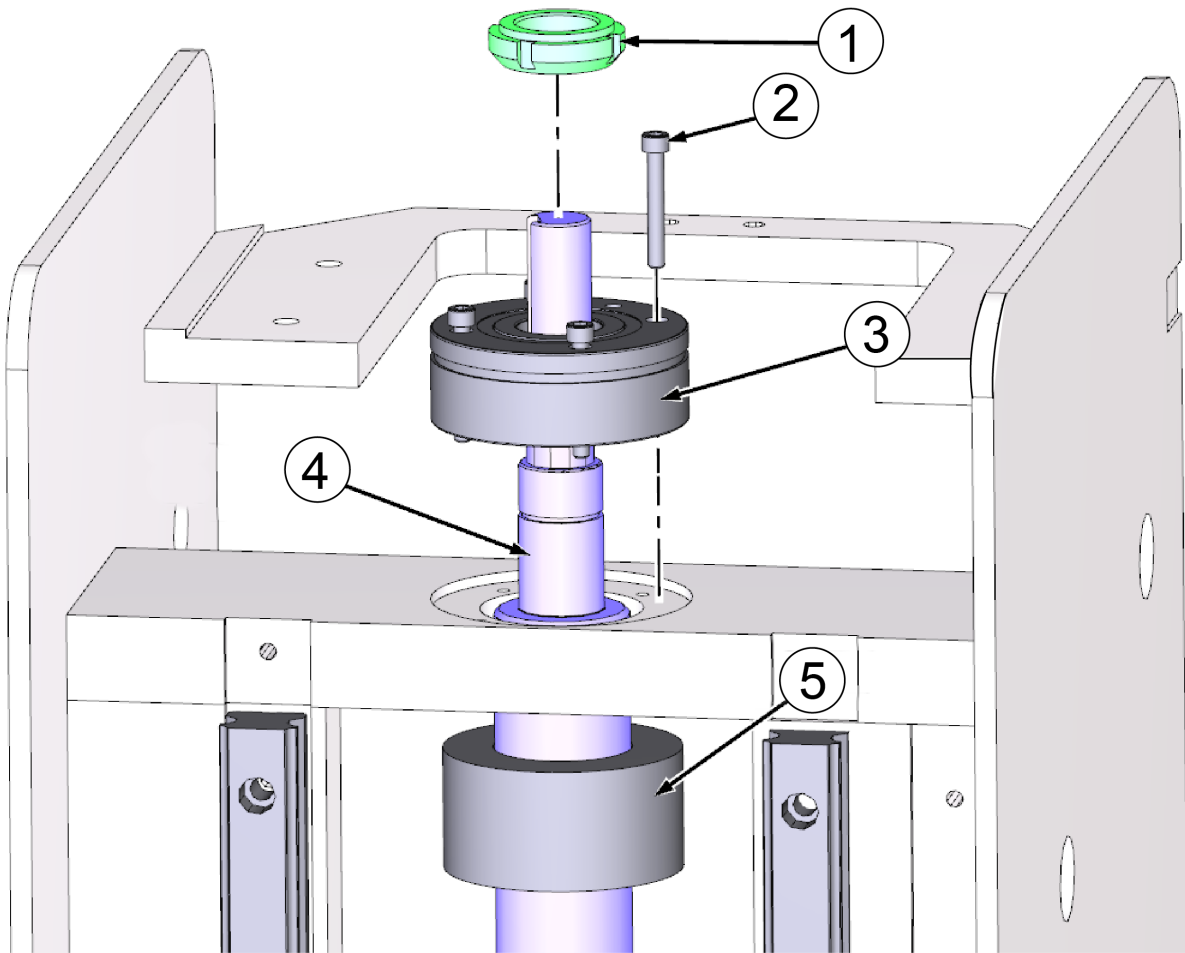

Outer Wire Track Assembly

Mounts

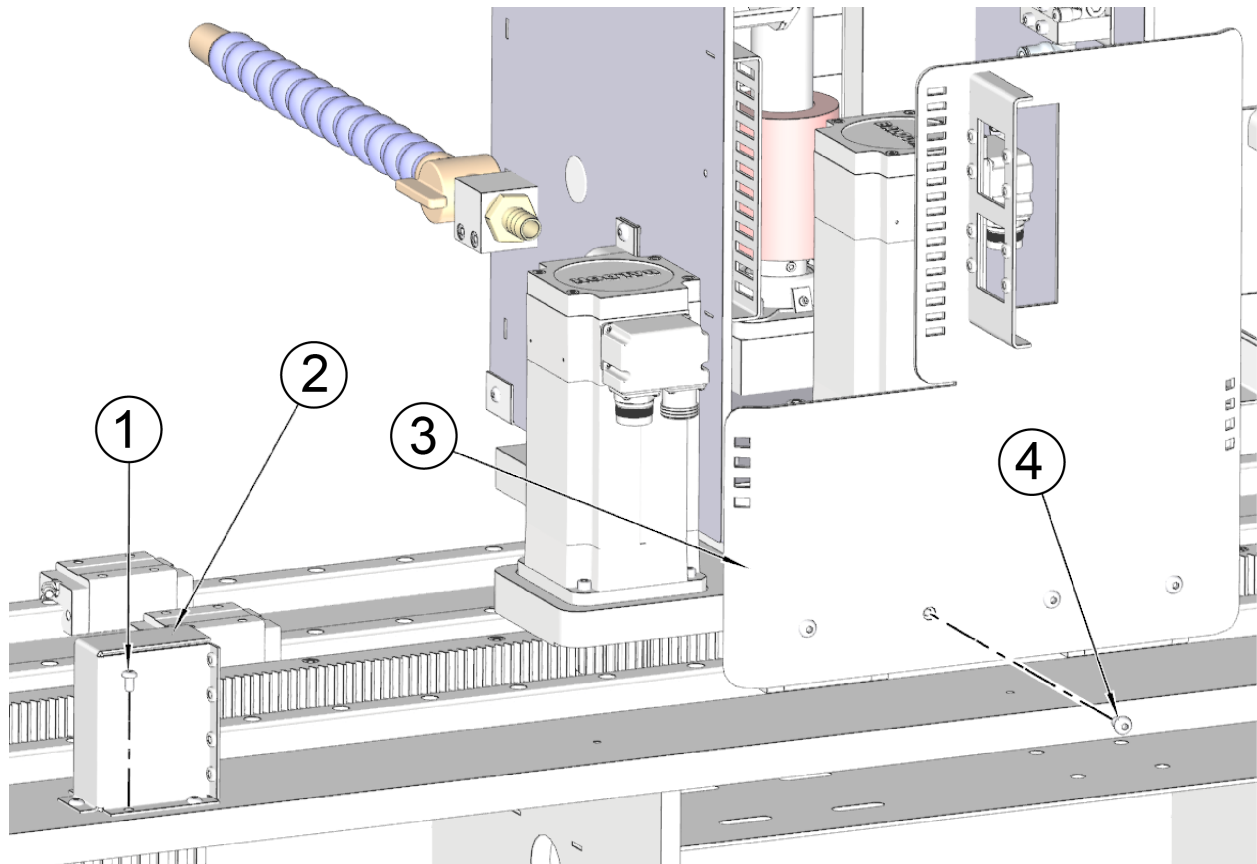

Wire Tracks

ITEM	PART #	DESCRIPTION
1	MF-88	SOCKET BUTTON HEAD SCREW 10-24 X 3/8"
2	514-14-48D	MOUNT, X AXIS CABLE CHAIN
3	514-14-40	MOUNT, CARRIAGE CABLE CHAIN
4	MF-11	SOCKET HEAD CAP SCREW 1/4-20 X 3/8"

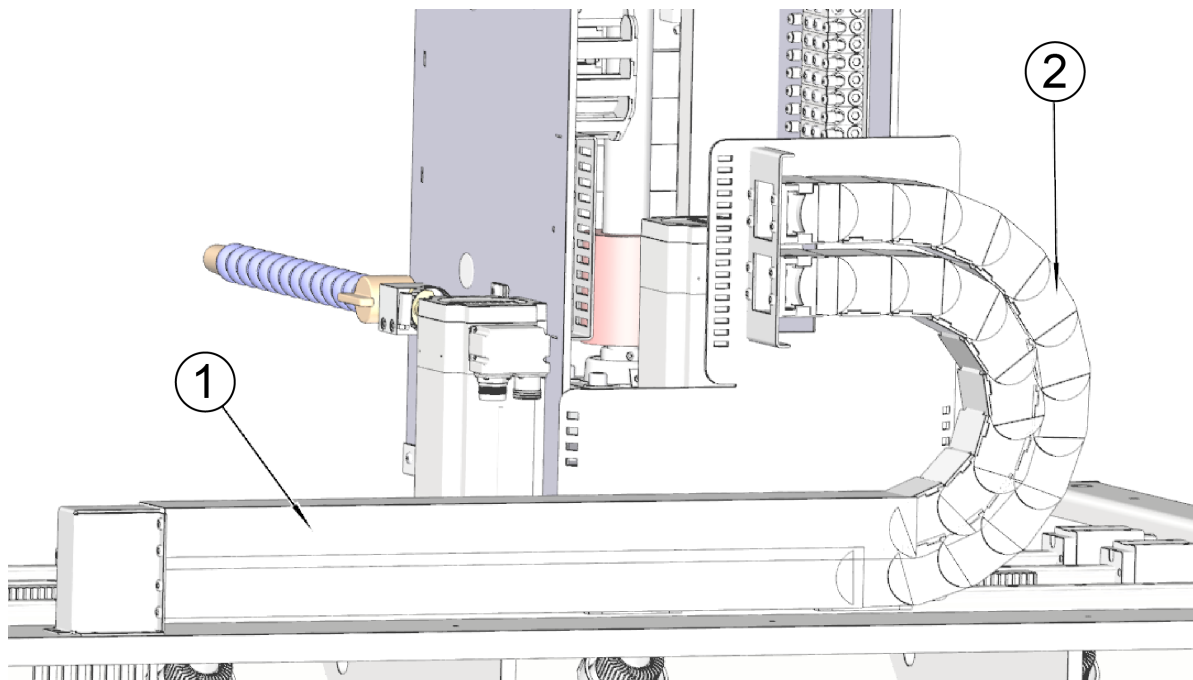

ITEM	PART #	DESCRIPTION
1	514-14-49A	CHAIN, X AXIS SHORT CABLE
2	514-14-49B	CHAIN, X AXIS LONG CABLE

Spindle Drive Assembly

Outer Components

ITEM	PART #	DESCRIPTION
1	514-13-82B	COUPLING
2	514-13-83A	PULLEY, SPINDLE HUB
3	514-4-17J	CONNECTOR, MALE - 1/8" OD TO 10-32
4	100-82-2	SCREW, SET-BRASS GIB - 3/16" LONG
5	514-14-37	HOUSING, SPINDLE
6	514-14-38	NUT, HONE HOUSING SPANNER
7	514-13-70	BEARING
8	514-13-62	SPINDLE HOUSING
9	11001C	BEARING NUT

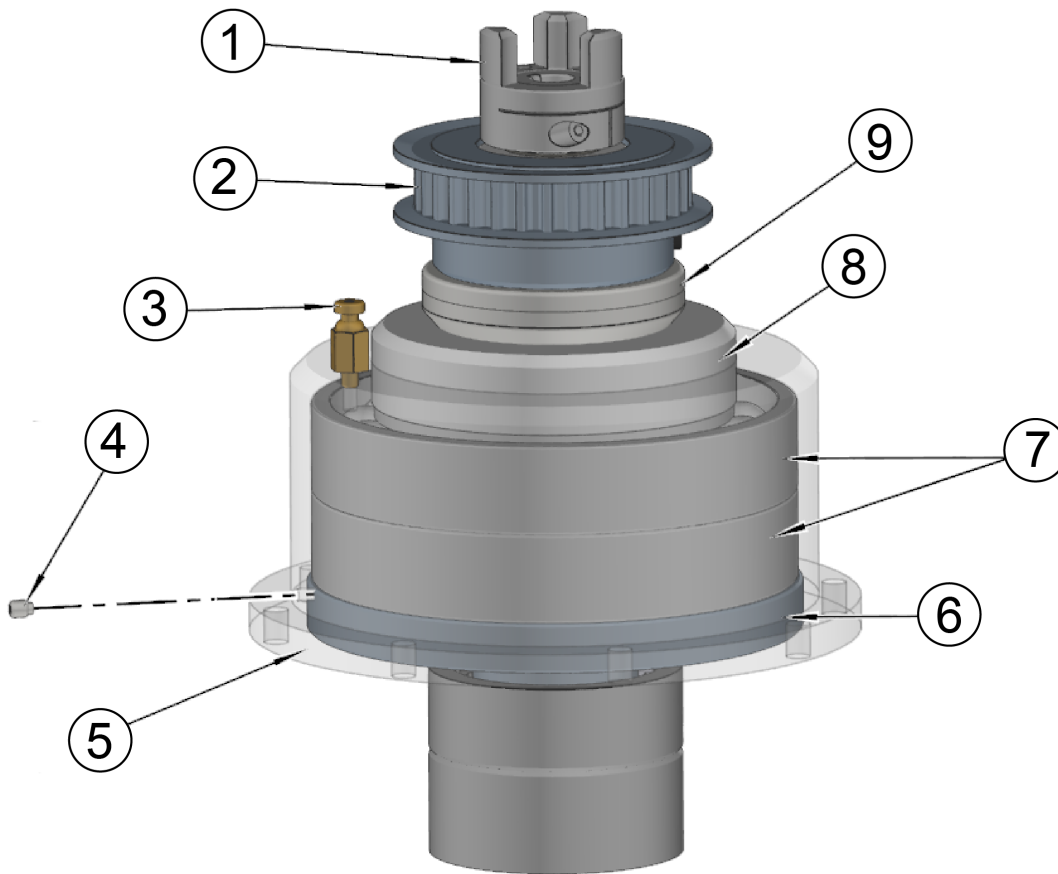

Inner Components

ITEM	PART #	DESCRIPTION
1	514-13-51	HUB, HONE DRIVE
2	514-13-50B	COUPLING, HONE
3	514-13-52	NOSE, SPINDLE
4	MF-248	SOCKET BUTTON HEAD SCREW 1/4-20 X 3/8"
5	514-13-64	SHAFT, FEED OUT
6	514-13-65	COUPLER, FEED OUT
7		5/32 X 1 ROLL PIN
8	514-13-57	NUT, KWIK SWITCH
9	514-13-53	WASHER, URETHANE SPINDLE
10	514-13-50C	BEARING, HONE HEAD
11	514-13-64A	SPACER, COUPLING

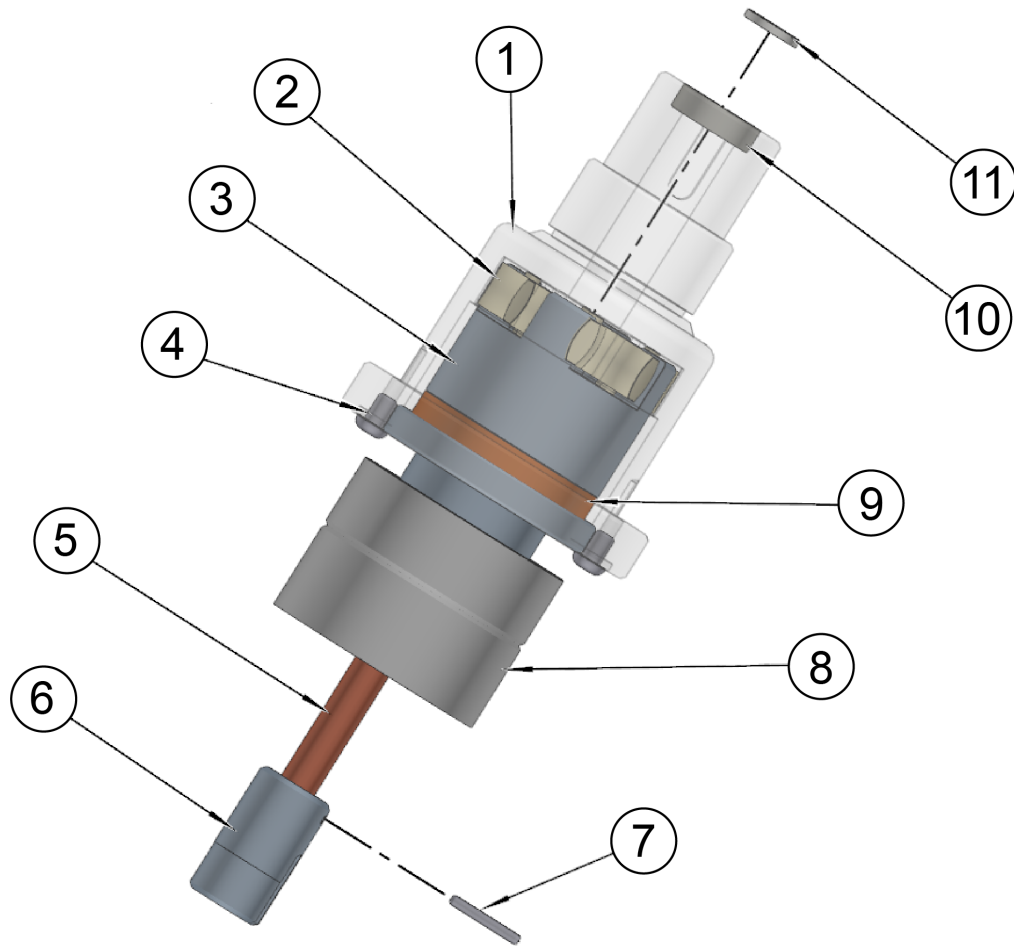

Spindle Drive Carriage Assembly

Oil Lines and Wire Track Attachments

ITEM	PART #	DESCRIPTION
1	502-12-12	CLAMP, OIL HOSE (1/8)
2	MF-86	SOCKET BUTTON HEAD SCREW 8-32 X 1/4"
3	514-14-57	CARRIAGE, SPINDLE
4	MF-248	SOCKET BUTTON HEAD SCREW 1/4-20 X 3/8"
5	514-14-48	MOUNT, Z AXIS CABLE CHAIN

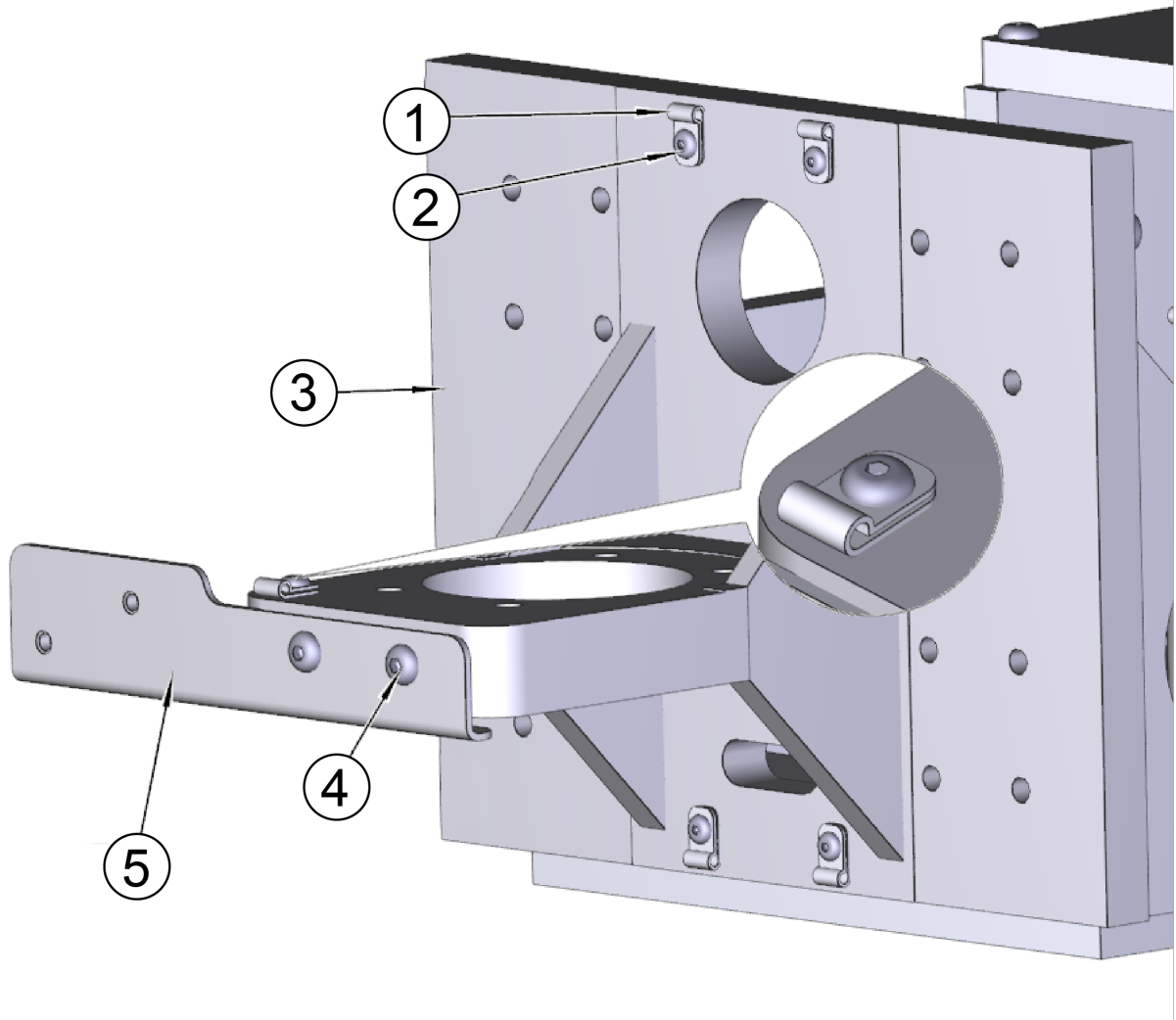

Feed Motor Assembly

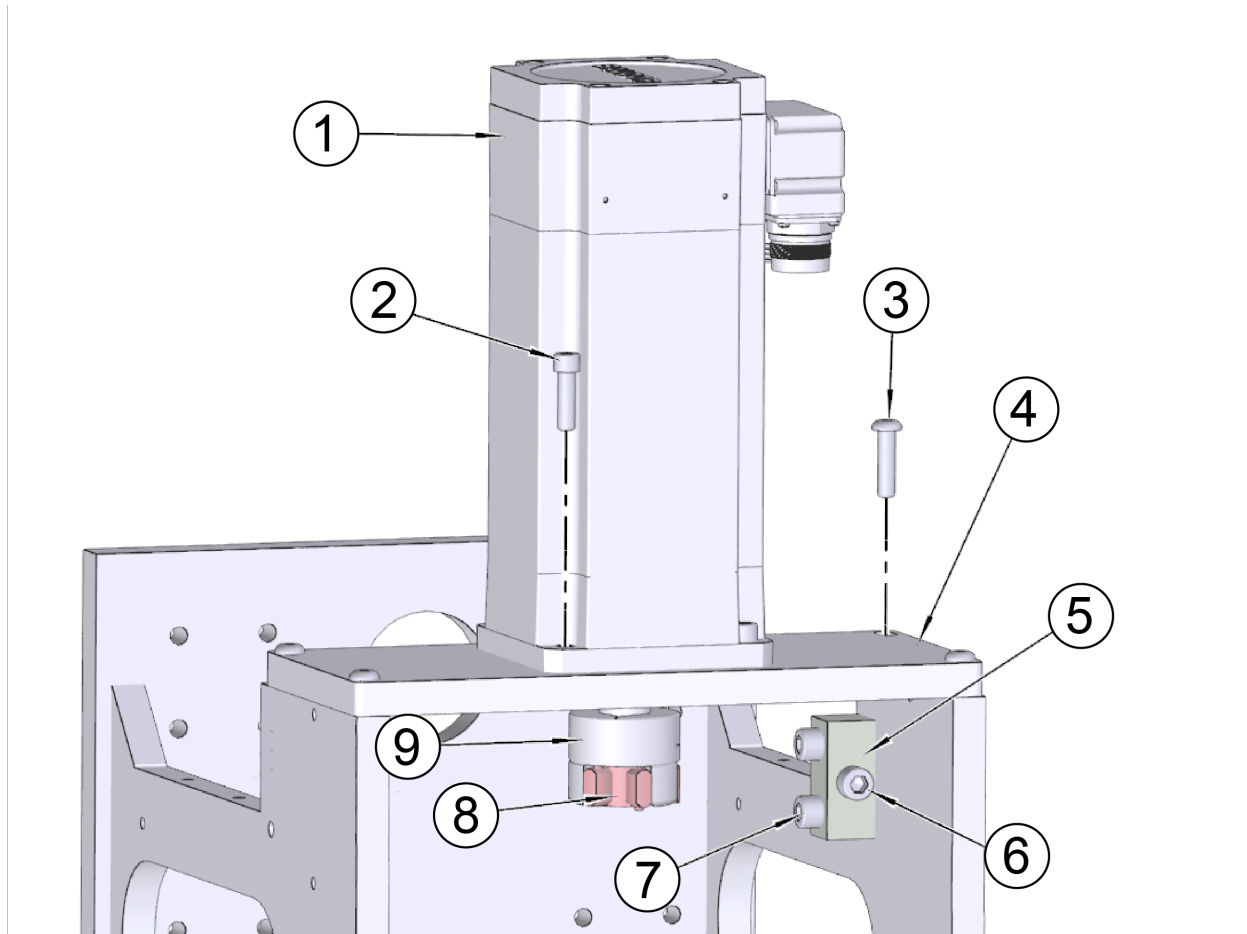

ITEM	PART #	DESCRIPTION
1	9020T	MOTOR, STONE FEED
2		1/4-20 X 7/8 SOCKET HEAD CAP SCREW
3		1/4-20 X 1 BUTTON HEAD CAP SCREW
4	514-13-11B	MOUNT, MOTOR FEED OUT
5	6451Q	BLOCK, ADJUSTING-BELT-SERVO MOTOR
6	MF-24	SOCKET HEAD CAP SCREW 5/16-18 X 1 1/4"
7	MF-23	SOCKET HEAD CAP SCREW 5/16-18 X 1"
8	514-13-82C	COUPLING, SPIDER
9	514-13-82A	COUPLING, MOTOR

Lower Section

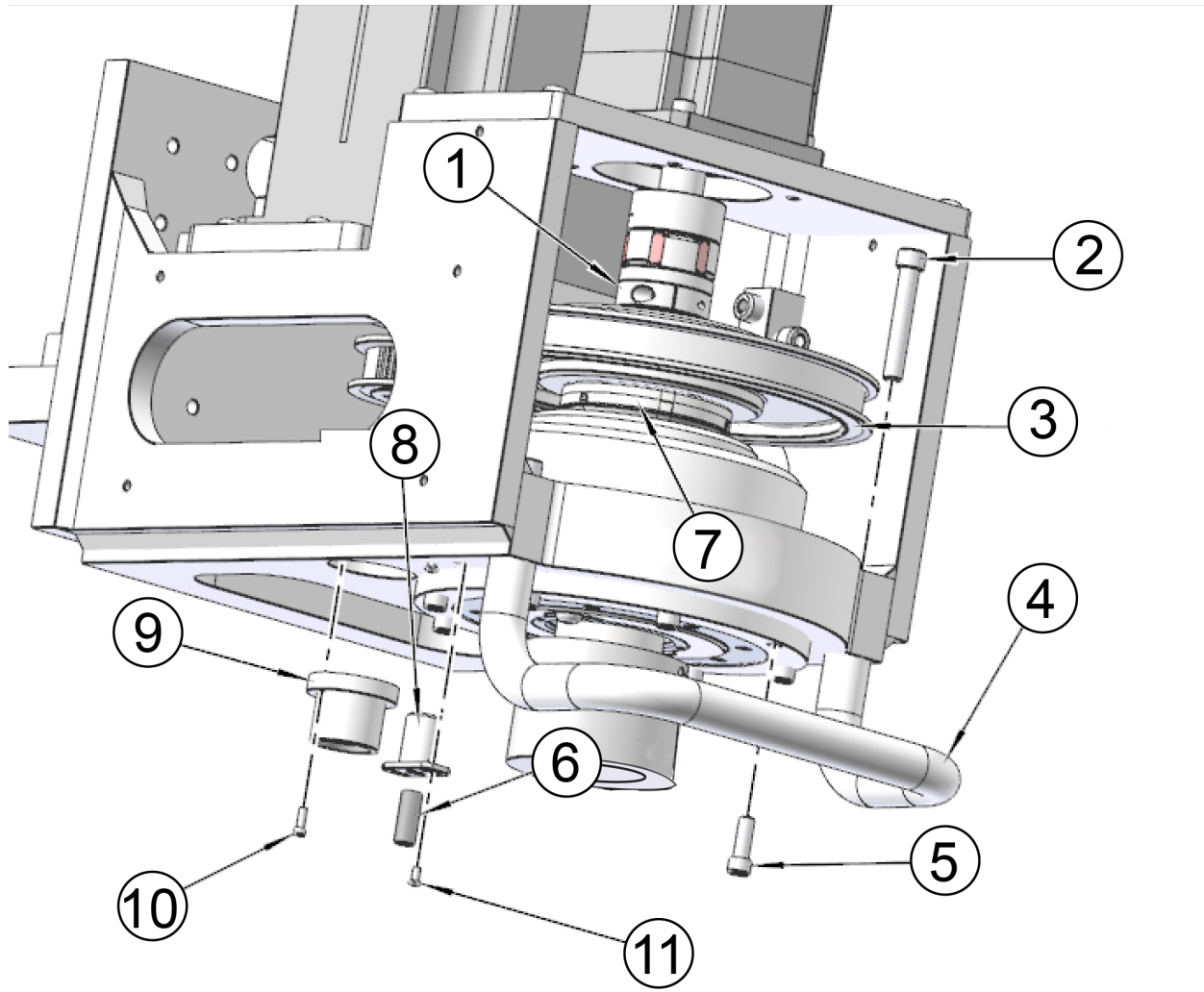

ITEM	PART #	DESCRIPTION
1	514-13-82B	COUPLING
2	MF-27	SOCKET HEAD CAP SCREW 5/16-18 X 2"
3	514-13-83P	PULLEY, SPINDLE
4	514-14-56D	HANDLE, CABINET
5	MF-14	SOCKET HEAD CAP SCREW 1/4-20 X 3/4"
6	514-14-37B	LASER, LINE
7	11001C	BEARING NUT
8	514-14-37A	HOUSING, LASER LINE
9	6457A	LIGHT, SPINDLE
10		4-40 X 3/8 SOCKET HEAD CAP SCREW
11		4-40 X 1/4 BUTTON HEAD CAP SCREW

Spindle Drive Motor Assembly

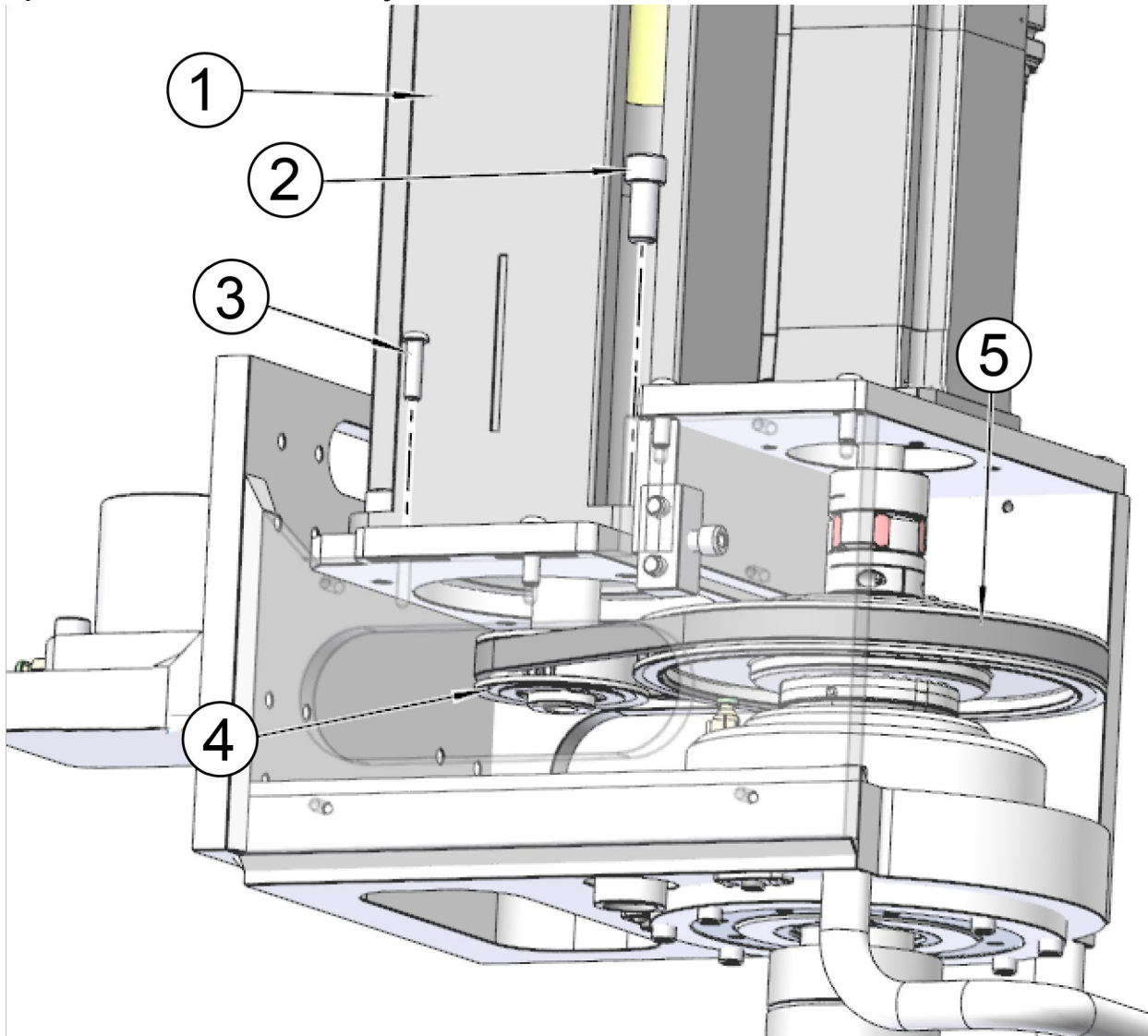

Spindle Drive Cover

ITEM	PART #	DESCRIPTION
1	514-14-33	MOTOR, SPINDLE
2	MF-39	SOCKET HEAD CAP SCREW 7/16-14 X 1"
3		1/4-20 X 1 BUTTON HEAD CAP SCREW
4	514-13-83Q	PULLEY, SPINDLE MOTOR
5	514-13-83S	BELT, SPINDLE DRIVE
ITEM	PART #	DESCRIPTION
1	514-14-46A	HOOD
2	MF-248	SOCKET BUTTON HEAD SCREW 1/4-20 X 3/8"



Electrical Enclosure

Door Assembly

Outside Parts

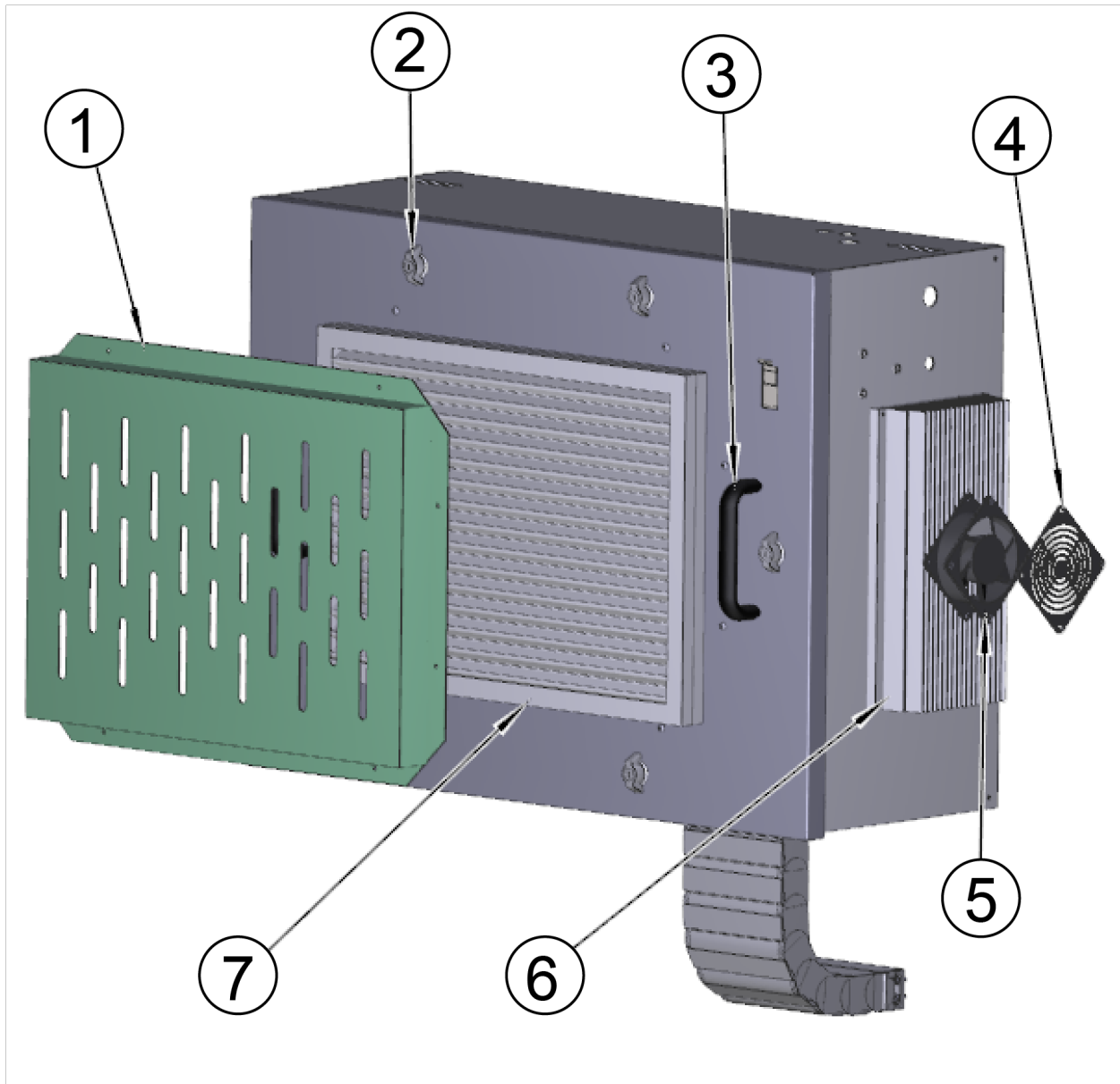

ITEM	PART #	DESCRIPTION
1	9030H	FILTER HOUSING
2	903E	DOOR LATCH
3	650-1-29G	HANDLE
4	7192B	GUARD, FAN
5	7192	FAN, ELECTRONIC ENCLOSURE
6	9023Z	SPINDLE AMP HEAT SINK
7	9030P	AIR FILTER

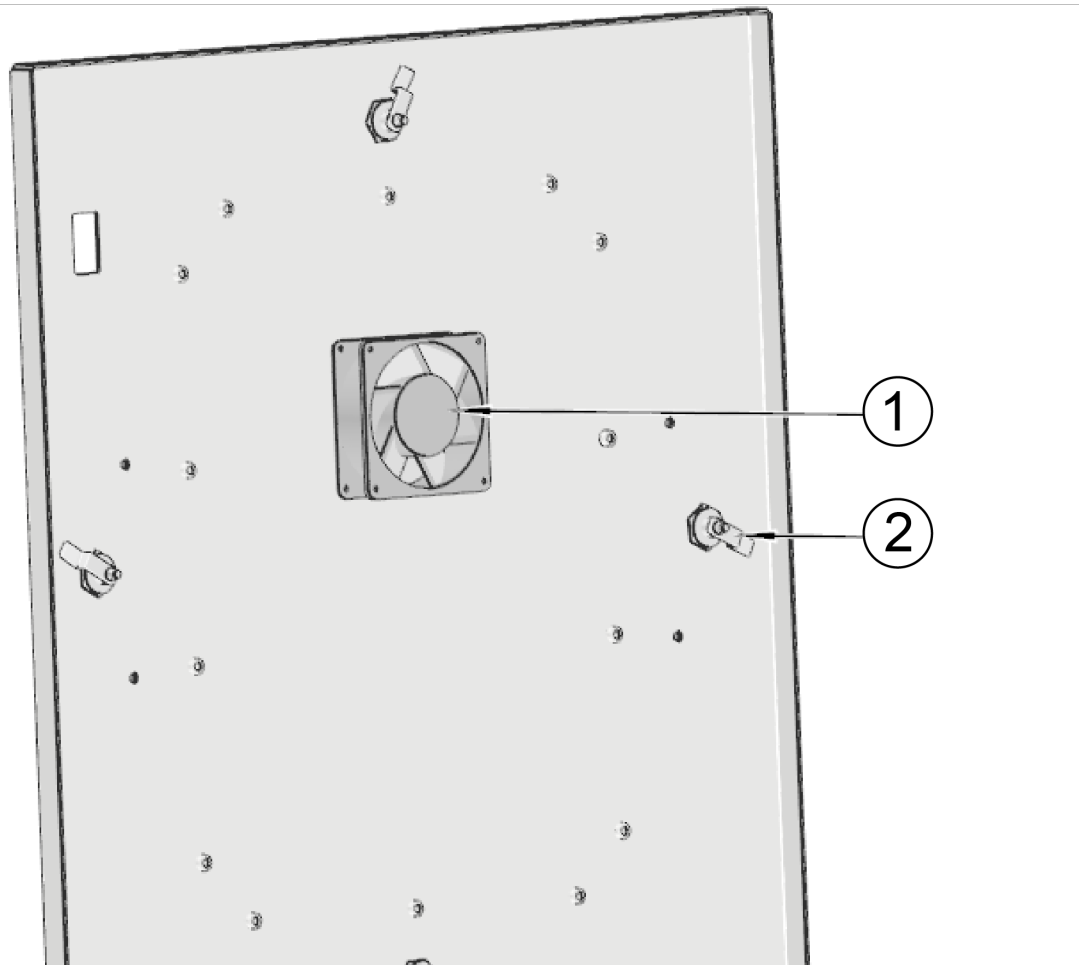
Inside Parts

ITEM	PART #	DESCRIPTION
1	7192	FAN, ELECTRONIC ENCLOSURE
2	903E	DOOR LATCH

Electrical Panel Assembly

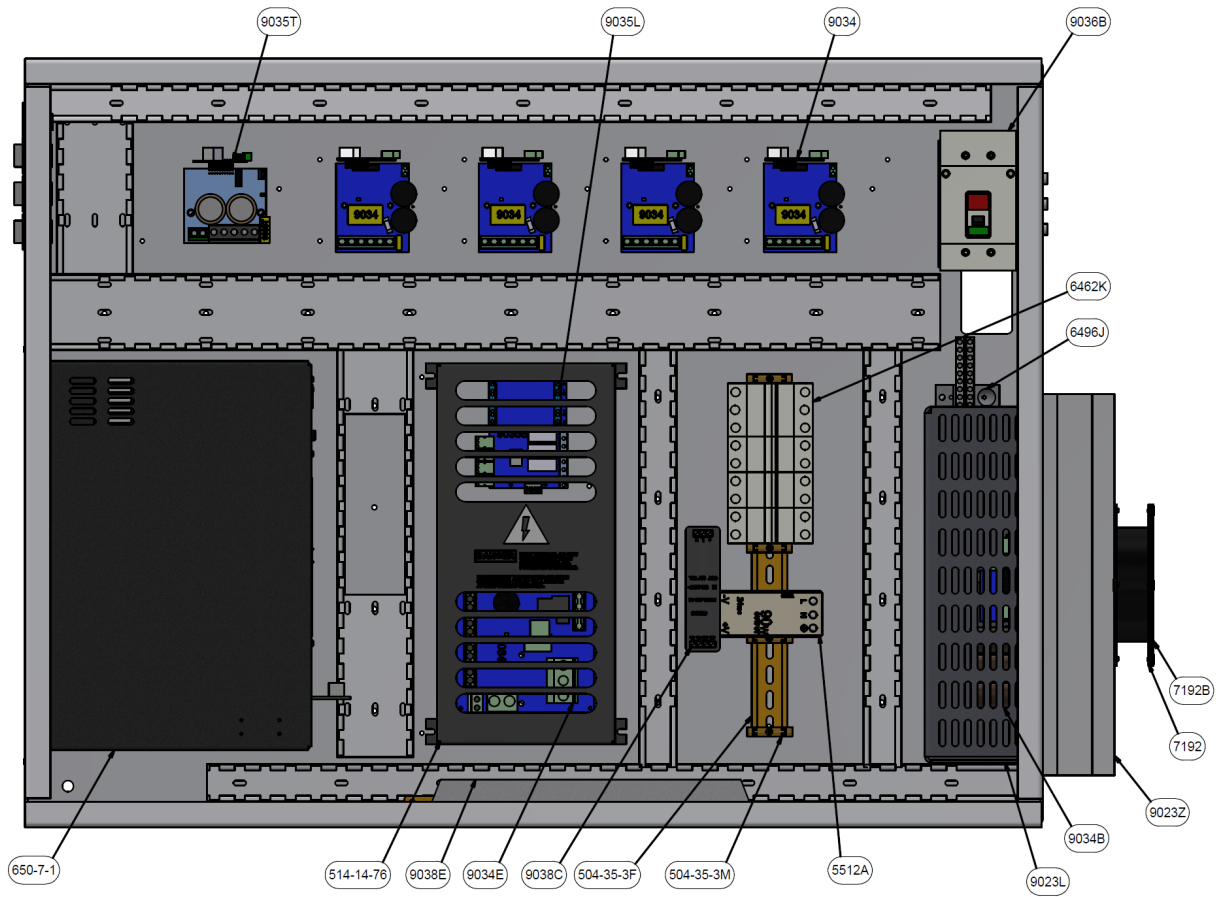

Control Pendant Assembly

Outer Components

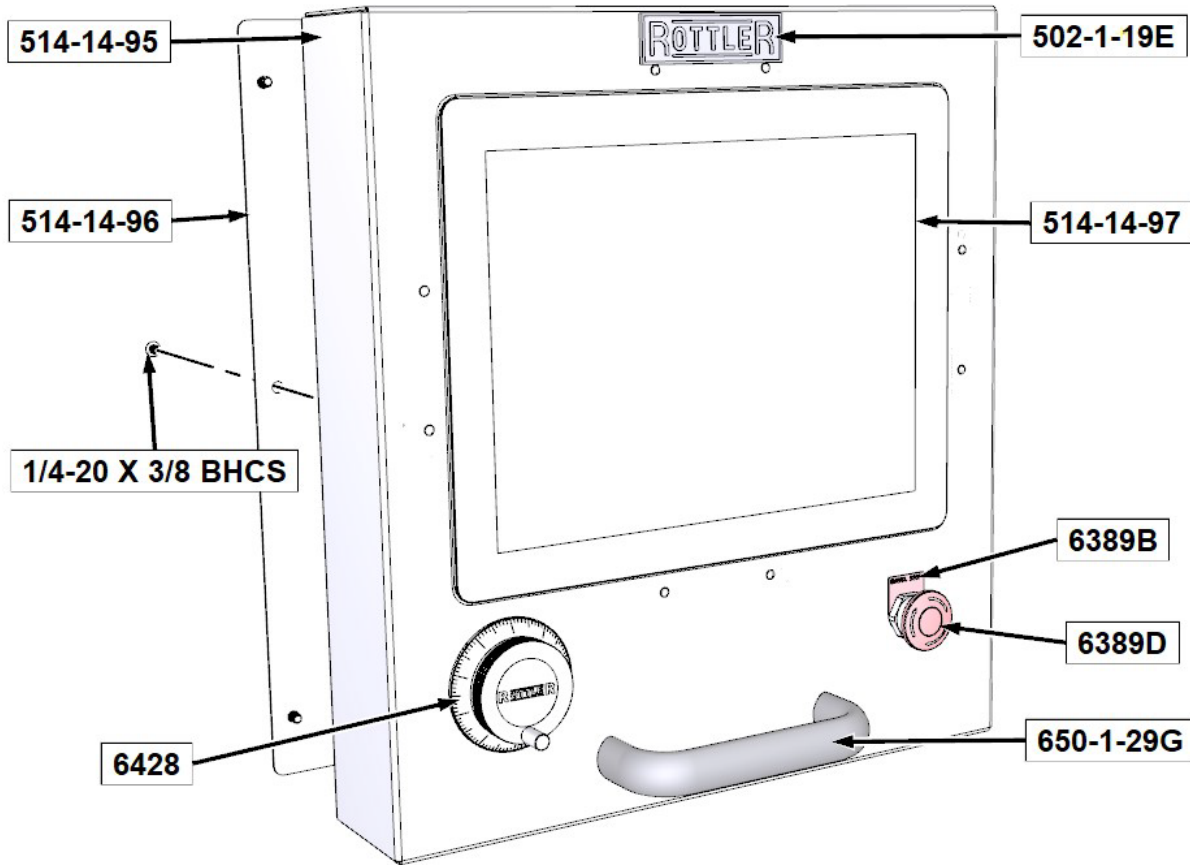

Pendant Mount

ITEM	PART #	DESCRIPTION
1	7322B	COVER, PENDANT SUPPORT
2	MF-86A	SOCKET BUTTON HEAD SCREW 8-32 X 3/8"
3	7322C	BEARING, SLEWING RING
4		8-32 X 5/8 SOCKET HEAD CAP SCREW
5	7322A	BRACKET, PENDANT SUPPORT
6	MF-86A	SOCKET BUTTON HEAD SCREW 8-32 X 3/8"
7	MF-92	SOCKET BUTTON HEAD SCREW 1/4-20 X 3/4"

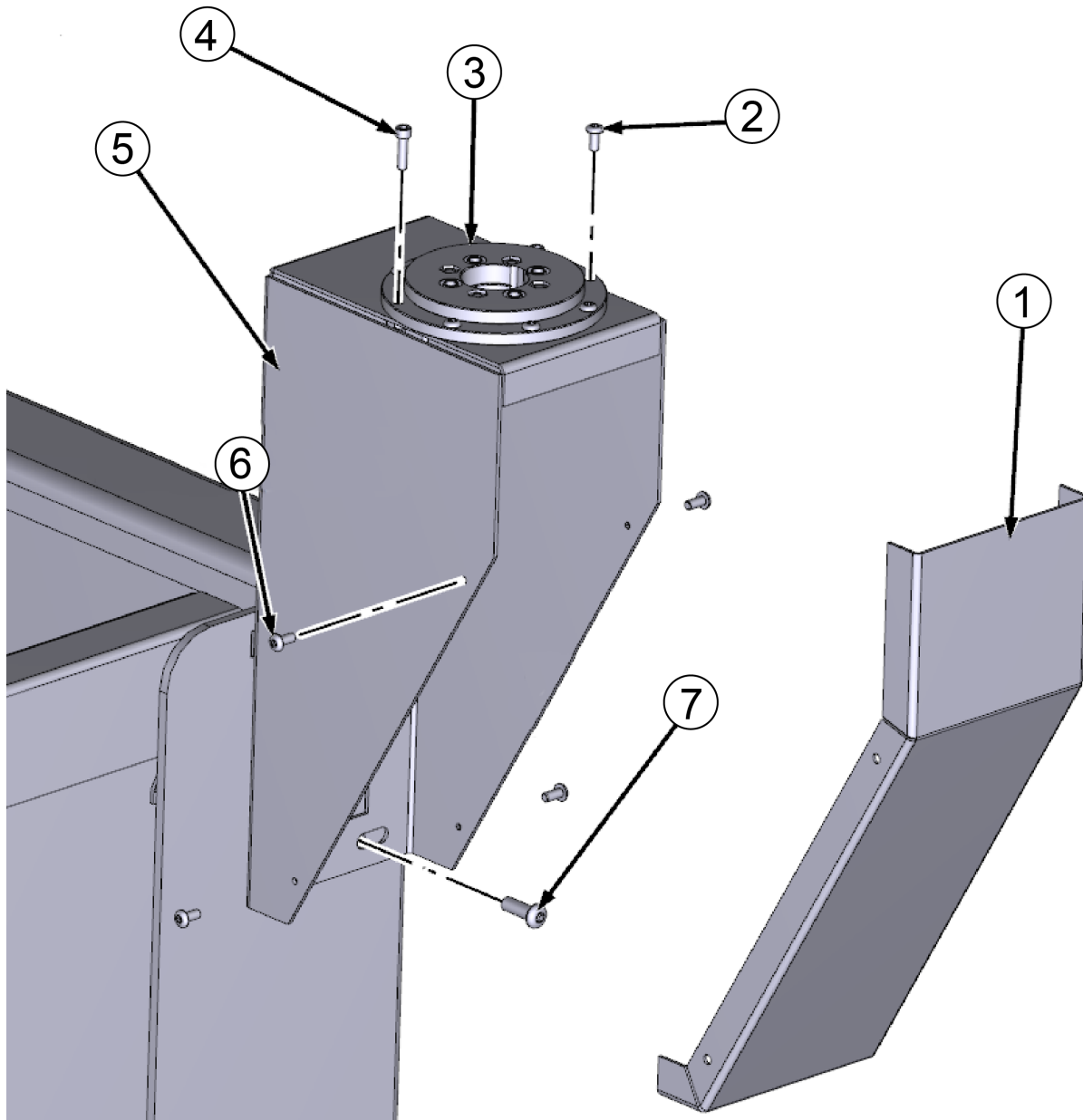

Coolant Sump Tank

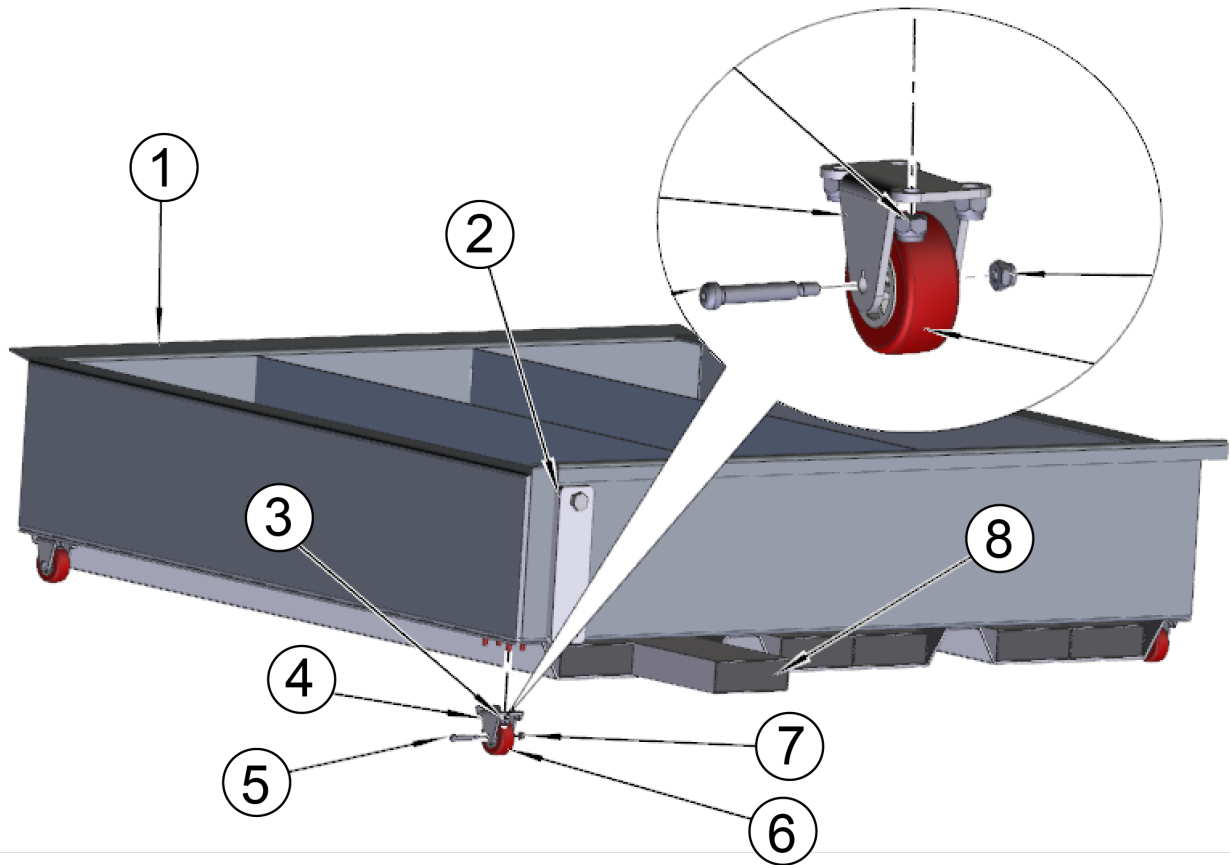

ITEM	PART #	DESCRIPTION
1	514-14-52A	TANK, COOLANT
2	514-14-52C	GLASS, SIGHT
3	MF-186A	NYLOCK NUTS 1/4-20
4	514-14-52F	CASTER, WHEEL & BRACKET
5	502-3-37A	BOLT, SOCKET HS SHOULDER 1/4" X 1 1/4"
6	514-14-52B	WHEEL, 2" CASTER
7	514-6-26H	LOCKNUT, 10-24 FIN. NYLON PLTD
8	514-7-65T	MAGNET

SDS

The Safety Data Sheets list shown in this section are the substances and materials that an operator is most likely to come in contact with while using this machine.

Other substances and materials are used in the manufacture, testing, and shipping of this machine. A complete list of the Safety Data Sheets of substances and materials used by Rottler Manufacturing during manufacturing, testing, and shipping is located on the Manual flash drive shipped with the machine. Safety Data Sheets are also located on the company web site: <http://www.rottlermfg.com/documentation.php>

1) Rottler Honing Coolant 514-4-71C (Yumate SC-870C)

2) Multi-Way Oil

1. IDENTIFICATION OF THE SUBSTANCE/PREPARATION
Product Identifier
Product Name YUMATE SC-870C

Other Means of Identification
Product Code YUMATE SC-870C

Synonyms None

Recommended Use of the Chemical and Restrictions on Use
Recommended Use Water soluble metalworking fluid

Uses advised against No information available

Details of the Supplier of the Safety Data Sheet
Manufacturer Address Yushiro Manufacturing America, Inc.
 783 West Mausoleum Road
 Shelbyville, IN 46176
 Telephone: 317-398-9862

Emergency Telephone Number
Emergency Telephone Chemtrec 1-800-424-9300

2. HAZARDS IDENTIFICATION
Classification
OSHA Regulatory Status

This chemical is considered hazardous by the 2012 OSHA Hazard Communication Standard (29 CFR 1910.1200)

Serious eye damage/eye irritation:	Category 1
Skin sensitization:	Category 1B
Reproductive toxicity:	Category 2
Specific target organ toxicity (repeated exposure):	Category 2

Label Elements

Danger Hazard Statements	Emergency Overview
Causes serious eye damage May cause an allergic skin reaction Suspected of damaging fertility or the unborn child May cause damage to organs through prolonged or repeated exposure Harmful to aquatic life with long lasting effects	

Appearance: No information available

Physical State: Liquid

Odor: Amines

Precautionary Statements – Prevention:

 Obtain special instruction before use
 Do not handle until all safety precautions have been read and understood
 Use personal protective equipment as required
 Contaminated work clothing should not be allowed out of the workplace
 Wear protective gloves
 Do not breath dust/fume/gas/mist/vapors/spray
 Avoid release into the environment

Precautionary Statements – Response:

 IF exposed or concerned: Get medical advice/treatment
 Specific treatment (see Section ??)
 IF IN EYES: Rinse cautiously with water for several minutes. Remove contact lenses, if present and easy to do. Continue rinsing.
 Immediately call a POISON CENTER or doctor/physician
 IF ON SKIN: Wash with plenty of soap and water. If skin irritation or rash occurs: Get medical advice/attention.
 Wash contaminated clothing before reuse.

Precautionary Statements – Storage:

Store locked up

Precautionary Statements – Disposal:

Dispose of contents/container to an approved waste disposal plant

Hazards Not Otherwise Classified (HNOC)**Other Information:**

May be harmful if swallowed: Unknow acute toxicity, 1.9% of the mixture consists of ingredient(s) of unknow toxicity

3. COMPOSITION/INFORMATION ON INGREDIENTS

Chemical Name	CAS No	weight-%	Trade Secret
Triethanolamine	102-71-6	10 - 30	*
Monoethanolamine	141-43-5	1 - 5	*
Boric acid	10043-35-3	1 - 5	*

Some specific chemical identities and the exact percentages of composition have been withheld as trade secrets.

4. FIRST AID MEASURES**Eye Contact:** Rinse thoroughly with plenty of water for at least 15 minutes, lifting lower and upper eyelids. Consult a physician.**Skin Contact:** Wash off immediately with soap and plenty of water. Wash contaminated clothing before reuse. If symptoms persist, call a physician.**Inhalation:** Remove to fresh air.**Ingestion:** Clean mouth with water and drink afterwards plenty of water.**Most important symptoms and effects, both acute and delayed:****Symptoms:** No information available**Indication of any immediate medical attention and special treatment needed****Note to Physicians:** Treat symptomatically**5. FIREFIGHTING MEASURES****Suitable Extinguishing Media:**

Dry chemical, foam, carbon dioxide, water spray, or fog is recommended.

Unsuitable Extinguishing Media:

CAUTION: Use of water spray when fighting fire may be inefficient.

Specific Hazards arising from the Chemical:

No information available

Hazardous combustion products:

Incomplete combustion and thermolysis may produce gasses of varying toxicity such as carbon monoxide, carbon dioxide, various hydrocarbons, aldehydes, and soot. These may be highly dangerous if inhaled in confined spaces or at high concentrations.

Explosion Data:**Sensitivity to Mechanical Impact:** None**Sensitivity to Static Discharge:** None**Protective equipment and precautions for firefighters:**

As in any fire, wear self-contained breathing apparatus pressure-demand, MSHA/NIOSH (approved or equivalent) and full protective gear.

6. ACCIDENTAL RELEASE MEASURES**Personal precautions, protective equipment, and emergency procedures:**

Avoid contact with eyes and skin. Use personal protective equipment as required. Ensure adequate ventilation, especially in confined areas.

Environmental Precautions:

Avoid release to the environment. Do not flush into surface water or sanitary sewer system. See Section 12 for additional ecological information. Dispose of contents/container to an approved waste disposal plant.

Methods for Containment:

Prevent further leakage or spillage if safe to do so.

Methods for Cleaning Up:

Soak up with inert absorbent material

7. HANDLING AND STORAGE

Precautions for Safe Handling:

Use personal protection equipment as required. Avoid contact with skin, eyes, or clothing. Ensure adequate ventilation, especially in confined areas

Conditions for Safe Storage, including any Incompatibilities:

Keep from freezing. Protect from extremes of temperature and direct sunlight. Keep container tightly closed in a dry and well-ventilated place.

Incompatible Materials:

Acids. Strong oxidizing agents. Nitrites and nitrosating agents.

8. EXPOSURE CONTROLS/PERSONAL PROTECTION

Exposure Guidelines

Chemical Name	ACGIH TLV	OSHA PEL	NIOSH IDLH
Triethanolamine	TWA: 5 mg/m ³	-	-
Monoethanolamine	STEL: 6 ppm TWA: 3 ppm	TWA: 3 ppm TWA: 6 mg/m ³ (vacated) TWA: 3 ppm (vacated) TWA: 8 mg/m ³ (vacated) STEL: 6 ppm (vacated) STEL: 15 mg/m ³	IDLH: 30 ppm TWA: 3 ppm TWA: 8 mg/m ³ STEL: 6 ppm STEL: 15 mg/m ³
Boric acid	STEL: 6 mg/m ³ inhalable fraction TWA: 2 mg/m ³ inhalable fraction	-	-

Engineering Controls:

Showers, Eyewash stations, Ventilation Systems

Individual Protection Measures, such as Personal Protective Equipment

Eye/Face Protection:

Wear safety glasses with side shields (or goggles). Avoid contact with eyes.

Skin and Body Protection:

Wear protective gloves and protective clothing. Avoid contact with skin and clothing. Selection of protective clothing depends on work conditions.

Respiratory Protection:

If exposure limits are exceeded or irritation is experienced, NIOSH/MSHA approved respiratory protection should be worn. Positive pressure supplied air respirators may be required for high airborne contaminant concentrations. Respiratory protection must be provided in accordance with current local regulations.

General Hygiene Considerations:

Handle in accordance with good industrial hygiene and safety practice.

9. PHYSICAL AND CHEMICAL PROPERTIES

Information on Basic Physical and Chemical Properties

Physical State	Liquid	Odor	Amines
Appearance	No information available	Odor Threshold	No information available
Color	Light yellow		
Property		Values	Remarks / Method
pH		8.85	
Melting Point/Freezing Point		No information available	
Boiling Point/Boiling Range		No information available	
Flash Point		No information available	
Evaporation Rate		No information available	
Flammability (solid, gas)		No information available	
Flammability Limit in Air			
Upper Flammability Limit		No information available	
Lower Flammability Limit		No information available	
Vapor Pressure		No information available	
Vapor Density		No information available	
Specific Gravity		1.059	@20°C
Water Solubility		Miscible in water	
Solubility in other Solvents		No information available	
Partition Coefficient		No information available	
Autoignition Temperature		No information available	
Decomposition Temperature		No information available	
Kinematic Viscosity		No information available	
Explosive Properties		No information available	
Oxidizing Properties		No information available	
Other Information			
Softening Point		No information available	
Molecular Weight		No information available	
VOC Content (%)		No information available	
Density		8.8 lbs/gal	
Bulk Density		No information available	

10. STABILITY AND REACTIVITY

Reactivity:

No data available

Chemical Stability:

Stable under recommended storage conditions

Possibility of Hazardous Reactions:

None under normal processing

Hazardous Polymerization:

Hazardous polymerization does not occur

Conditions to Avoid:

Extremes of temperature and direct sunlight

Incompatible Materials:

Acids, strong oxidizing agents, nitrites, and nitrosating agents

Hazardous Decomposition Products:

No hazardous decomposition products if stored and handled under normal conditions

11. TOXICOLOGICAL INFORMATION

Information on Likely Routes of Exposure

Product Information:	No data available
Inhalation:	Inhalation of vapors at high concentrations may cause mild irritation of respiratory system.
Eye Contact:	Contact with eyes may cause serious eye damage.
Skin Contact:	Repeated or prolonged skin contact may result in dermatitis. May cause sensitization by skin contact.
Ingestion:	May be harmful if swallowed

Chemical Name	Oral LD50	Dermal LD50	Inhalation LC50
Triethanolamine	=4190 mg/kg (Rat)	>20 mL/kg (Rabbit); >16 mL/kg (Rat)	-
Monoethanolamine	=1720 mg/kg (Rat)	=1 mL/kg (Rabbit); =1000 mg/kg (Rat)	-
Boric Acid	=2660 mg/kg (Rat)	>2000 mg/kg (Rabbit)	>0.16 mg/L (Rat) 4h

Information on Toxicological Effects

Symptoms No information available

Delayed and Immediate Effects, as well as Chronic Effects from Short- and Long-term Exposure

Skin Corrosion/Irritation:	Repeated exposure may cause skin dryness or cracking
Serious Eye Damage/Irritation:	Risk of serious damage to eyes
Sensitization:	May cause sensitization by skin contact
Germ Cell Mutagenicity:	No information available
Carcinogenicity:	This product does not contain any components at concentrations at or above 0.1% that are listed as carcinogens or potential carcinogens by OSHA, IARC or NTP.
Reproductive Toxicity:	Product contains boric acid. Animal ingestion studies in several species indicate that, at high doses, boric acid may cause reproductive and developmental effects. Human epidemiological studies have not shown a negative effect on human fertility.
STOT – Single Exposure:	No information available
STOT – Repeated Exposure:	May cause damage to kidneys and liver through prolonged or repeated exposure.
Aspiration Hazard:	No information available

Numerical Measures of Toxicity – Product Information

Unknown Acute Toxicity: 1.9% of the mixture consists of ingredient(s) of unknown toxicity

The following values are calculated based on chapter 3.1 of the GHS document

ATEmix (oral): >3,000 mg/kg

12. ECOLOGICAL INFORMATION

Ecotoxicity:	Harmful to aquatic life
Persistence and Degradability:	No information available
Bioaccumulation:	No information available
Other Adverse Effects:	No information available

13. DISPOSAL CONSIDERATIONS

Waste Treatment Methods

Disposal of Wastes: Disposal should be in accordance with applicable regional, national, and local laws and regulations.

Contaminated Packaging: Do not reuse container

Chemical Name	California Hazardous Waste Status
Boric Acid 10043-35-3	Toxic

14. TRANSPORT INFORMATION

DOT: Not regulated

15. REGULATORY INFORMATION

International Inventories

TSCA: Complies
DSL/NDSL: Complies

Legend

TSCA United States Toxic Substances Control Act Section 8(b) Inventory
DSL/NDSL Canadian Domestic Substances List/Non-Domestic Substances List

US Federal Regulations

SARA 313 Section 313 of Title III of the Superfund Amendments and Reauthorization Act of 1986 (SARA). This product does not contain any chemicals which are subject to the reporting requirements of the Act and Title 40 of the Code of Federal Regulations, Part 372.

SARA 311/312 Hazard Categories

Acute Health Hazard Yes
Chronic Health Hazard Yes
Fire Hazard No
Sudden Release of Pressure Hazard No
Reactive Hazard No

CWA (Clean Water Act) This product contains substances classified as oil under Section 311 of the Clean Water Act and the Oil Pollution Act of 1990. Discharge or spills which produce a visible sheen on surface water or waterways leading to surface water must be reported to the National Response Center at 800-424-8802.

CERCLA This material, as supplied, contains one or more substances regulated as a hazardous substance under the Comprehensive Environmental Response Compensation and Liability Act (CERCLA) (40 CFR 302)

US State Regulations

California Proposition 65 This product contains the following Proposition 65 chemicals (Trace impurities, <<0.1%)

Chemical Name	California Proposition 65 Classification
Diethanolamine – 111-42-2	Carcinogen
N, N-Diethanolamine – 111-42-2	Carcinogen
1, 2-Dichloroethane – 107-06-2	Carcinogen
1, 4-Dioxane – 123-91-1	Carcinogen
Ethylenimine – 151-56-4	Carcinogen
Ethylene Oxide – 75-21-8	Carcinogen Developmental Female Reproductive Male Reproductive
Propylene Oxide – 75-56-9	Carcinogen

US EPA Label Information

EPA Pesticide Registration Number: Not applicable

16. OTHER INFORMATION

Issue Date: 17-Dec-2015
Revision Date: 29-Apr-2016
Revision Note: No information available

Disclaimer

The information provided in this Safety Data Sheet is correct to the best of our knowledge, information, and belief at the date of its publication. The information given is designed only as a guidance for safe handling, use, processing, storage, transportation, disposal, and release and is not to be considered a warranty or quality specification. The information relates only to the specific material designated and may not be valid for such material used in combination with any other materials or in any process, unless specified in the text.

End of Safety Data Sheet

Safety Data Sheet

According to OSHA HCS 2012 (29 CFR 1910.1200)
Health Canada HPR (SOR/2015-17), and
Mexico NOM-018-STPS-2015

SECTION 1: Identification

Product Identifier:	Multi-Way Oil HD
Other means of identification:	Phillips 66 Multi-Way Oil HD 22 Phillips 66 Multi-Way Oil HD 32
Code:	LBPH81776
Relevant identified uses:	Way Oil
Uses advised against:	All others
24 Hour Emergency Phone Number:	CHEMTREC: 1-800-424-9300 CHEMTREC Mexico: 01-800-681-9531

Manufacturer/Supplier	SDS Information	Customer Service
Phillips 66 Lubricants	URL: www.phillips66.com/SDS	U.S.: 800-368-7128
P.O. Box 4428	Phone: 800-762-0942	International: 1-832-765-2500
Houston, TX 77210	Email: SDS@P66.com	Technical Information
		1-877-445-9198

SECTION 2: Hazard Identification

Classified Hazards	Hazards Not Otherwise Classified (HNOC)
No classified hazards	PHNOC: None known HHNOC: None known
Label Elements	
No classified hazards	

SECTION 3: Composition/Information on Ingredients

Chemical Name	CASRN	Concentration
Distillates, petroleum, hydrotreated heavy paraffinic	64742-54-7	>40%
Distillates, petroleum, solvent-dewaxed heavy paraffinic	64742-65-0	>40%
Residual oils, petroleum, solvent-dewaxed	64742-62-7	>10%

All concentrations are percent by weight unless ingredient is a gas. Gas concentrations are in percent by volume.

SECTION 4: First Aid Measures

Eye Contact: If irritation or redness develops from exposure, flush eyes with clean water. If symptoms persist, seek medical attention.

Skin Contact: Remove contaminated shoes and clothing and cleanse affected area(s) thoroughly by washing with mild soap and water or a waterless hand cleaner. If irritation or redness develops and persists, seek medical attention.

Inhalation: First aid is not normally required. If breathing difficulties develop, move victim away from source of exposure and into fresh air in a position comfortable for breathing. Seek immediate medical attention.

Ingestion: First aid is not normally required; however, if swallowed and symptoms develop, seek medical attention

Most important symptoms and effects, both acute and delayed: Inhalation of oil mists or vapors generated at elevated temperatures may cause respiratory irritation. Accidental ingestion can result in minor irritation of the digestive tract, nausea, and diarrhea. Prolonged or repeated contact may dry skin and cause irritation.

Notes to Physician: Acute aspirations of large amounts of oil-laden material may produce a serious aspiration pneumonia. Patients who aspirate these oils should be followed for the development of long-term sequelae. Inhalation exposure to oil mists below current workplace exposure limits is unlikely to cause pulmonary abnormalities.

SECTION 5: Firefighting Measures

NFPA 704: National Fire Protection Association		
Health: 0 Flammability: 1 Instability: 00=minimal hazard		1=Slight Hazard
		2=Moderate Hazard
		3=Severe Hazard
		4=Extreme Hazard

Extinguishing Media: Dry chemical, carbon dioxide, foam, or water spray is recommended. Water or foam may cause frothing of materials heated above 212°F/100°C. Carbon dioxide can displace oxygen. Use caution when applying carbon dioxide in confined spaces. Simultaneous use of foam and water on the same surface is to be avoided as water destroys the foam.

Specific Hazards arising from the chemical:

Unusual Fire & Explosion Hazards: This material may burn but will not ignite readily. If container is not properly cooled, it can rupture in the heat of a fire.

Hazardous Combustion Products: Combustion may yield smoke, carbon monoxide, and other products of incomplete combustion. Oxides of sulfur, nitrogen, or phosphorus may also be formed.

Special protective actions for firefighters: For fires beyond the initial stage, emergency responders in the immediate hazard area should wear protective clothing. When the potential chemical hazard is unknown, in enclosed or confined spaces, a self-contained breathing apparatus should be worn. In addition, wear other appropriate protective equipment as conditions warrant (see Section 8). Isolate the hazard area and deny entry to unnecessary and unprotected personnel. Stop spill/release if it can be done safely. Move undamaged containers from immediate hazard area if it can be done safely. Water spray may be useful in minimizing or dispersing vapors and to protect personnel. Cool equipment exposed to fire with water if it can be done safely. Avoid spreading burning liquid with water used for cooling purposes.

See Section 9 for Flammability Properties including flash point and flammable (explosive) limits.

SECTION 6: Accidental Release Measures

Personal precautions, protective equipment, and emergency procedures: This material may burn but will not ignite readily. Keep all sources of ignition away from spill/release. Stay upwind and away from spill/release. Avoid direct contact with material. For large spillages, notify persons downwind of the spill/release, isolate immediate hazard area, and keep unauthorized personnel out. Wear appropriate protective equipment, including respiratory protection, as conditions warrant (see Section 8). See Sections 2 and 7 for additional information on hazards and precautionary measures.

Environmental Precautions: Stop and contain spill/release if it can be done safely. Prevent spilled material from entering sewers, storm drains, other unauthorized drainage systems, and natural waterways. Use water sparingly to minimize environmental contamination and reduce disposal requirements. If spill occurs on water, notify appropriate authorities and advise shipping of any hazard. Spills into or upon navigable waters, the contiguous zone, or adjoining shorelines that cause a sheen or discoloration on the surface of the water may require notification of the National Response Center (Phone number: 800-424-8802).

Methods and material for containment and cleaning up: Notify relevant authorities in accordance with all applicable regulations. Immediate cleanup of any spill is recommended. Dike far ahead of spill for later recovery or disposal. Absorb spill with inert material such as sand or vermiculite and place in suitable container for disposal. If spilled on water, remove with appropriate methods (e.g. skimming, booms, or absorbents). In case of soil contamination, remove contaminated soil for remediation or disposal in accordance with local regulations.

Recommended measures are based on the most likely spillage scenarios for this material; however, local conditions and regulations may influence or limit the choice of appropriate actions to be taken. See Section 13 for information on appropriate disposal.

SECTION 7: Handling and Storage

Precautions for Safe Handling: Keep away from flames and hot surfaces. Wash thoroughly after handling. Use good personal hygiene practices and wear appropriate personal protective equipment (see Section 8). Spills will produce very slippery surfaces. Do not enter confined spaces such as tanks or pits without following proper entry procedures such as ASTM D-4276 and 29 CFR 1910.146. Do not wear contaminated clothing or shoes.

Conditions for Safe Storage: Keep container(s) tightly closed and properly labeled. Use and store this material in cool, dry, well-ventilated areas away from heat and all sources of ignition. Store only in approved containers. Keep away from any incompatible material (see Section 10). Protect container(s) against physical damage.

“Empty” containers retain residue and may be dangerous. Do not pressurize, cut, weld, braze, solder, drill, grind, or expose such containers to heat, flame, sparks, or other sources of ignition. They may explode and cause injury or death. “Empty” drums should be completely drained, properly bunged, and promptly shipped to the supplier or a drum reconditioner. All containers should be disposed of in an environmentally safe manner and in accordance with governmental regulations. Before working on or in tanks which contain or have contained this material, refer to OSHA regulations, ANSI Z49.1, and other references pertaining to cleaning, repairing, welding, or other contemplated operations.

SECTION 8: Exposure Controls/Personal Protection

Occupational exposure limits				
The following constituents are the only constituents of the product which have a PEL, TLV or other recommended exposure limit. At this time the other constituents have no known exposure limits.				
Chemical Name	ACGIH	OSHA	Mexico	Phillips 66
Distillates, petroleum, hydrotreated heavy paraffinic	TWA: 5mg/m ³ STEL: 10 mg/m ³ as Oil Mist, if Generated	---	---	---
Distillates, petroleum, solvent-dewaxed heavy paraffinic	TWA: 5mg/m ³ STEL: 10 mg/m ³ as Oil Mist, if Generated	---	---	---
Residual oils, petroleum, solvent-dewaxed	TWA: 5mg/m ³ STEL: 10 mg/m ³ as Oil Mist, if Generated	---	---	---

Note: State, Local, or other agencies or advisory groups may have established more stringent limits. Consult an industrial hygienist or similar professional, or you local agencies, for further information.

Biological Occupational Exposure Limits

Note: This product, as supplied, does not contain any hazardous materials with occupational exposure limits established by the region-specific regulatory bodies

Engineering Controls: If current ventilation practices are not adequate to maintain airborne concentrations below the established exposure limits, additional engineering controls may be required.

Eye/Face Protection: The use of eye/face protection is not normally required; however, good industrial hygiene practice suggests the use of eye protection that meets or exceeds ANSI Z.87.1 whenever working with chemicals.

Skin/Hand Protection: The use of skin protection is not normally required; however, good industrial hygiene practice suggests the use of gloves or other appropriate skin protection whenever working with chemicals. Suggested protective materials: Nitrile rubber.

Respiratory Protection: Where there is potential for airborne exposure above the exposure limit, a NIOSH certified air purifying respirator equipped with R or P95 filters may be used.

A respiratory protection program that meets or is equivalent to OSHA 29 CFR 1910.134 and ANSI Z88.2 should be followed whenever workplace conditions warrant a respirator's use. Air purifying respirators provide limited protection and cannot be used in atmospheres that exceed the maximum use concentration (as directed by regulation or the manufacturer's instructions), in oxygen deficient (less than 19.5% oxygen) situations, or under conditions that are immediately dangerous to life and health (IDLH).

Suggestions provided in this section for exposure control and specific types of protective equipment are based on readily available information. Users should consult with the specific manufacturer to confirm the performance of their protective equipment. Specific situations may require consultation with industrial hygiene, safety, or engineering professionals.

SECTION 9: Physical and Chemical Properties

Note: Unless otherwise stated, values are determined at 20°C (68°F) and 760 mmHg (1atm). Data represent typical values and are not intended to be specifications.

Appearance:	Amber, Transparent	Flash Point:	> 320°F (160°C)
Physical Form:	Liquid	Test Method:	Pensky-Martens Closed Cup (PMCC), ASTM D93, EPA 1010
Odor:	Petroleum	Initial Boiling Point/Range:	No Data
Odor Threshold:	No Data	Vapor Pressure:	< 1mmHg
pH:	Not applicable	Partition Coefficient (n-octanol/water)(Kow):	No Data
Vapor Density (1=air):	>1	Melting/Freezing Point:	< -5°F (-15°C)
Upper Explosive Limits (vol % in air):	No Data	Auto-ignition Temperature:	No Data
Lower Explosive Limits (vol % in air):	No Data	Decomposition Temperature:	No Data
Evaporation Rate (nBuAc=1):	No Data	Specific Gravity (water=1):	0.86-0.89 @ 60°F (15.6°C)
Particle Size:	Not applicable	Bulk Density:	7.2-7.4 lbs/gal
Percent Volatile:	No Data	Viscosity:	5-20 cSt @ 100°C; 29-235 cSt @ 40°C
Flammability (solid, gas):	Not applicable	Pour Point:	< -5°F (-15°C)
Solubility in Water:	Insoluble		

SECTION 10: Stability and Reactivity

Reactivity: Not chemically reactive.

Chemical Stability: Stable under normal ambient and anticipated conditions of use.

Possibility of Hazardous Reactions: Hazardous reactions not anticipated.

Conditions to Avoid: Extended exposure to high temperatures can cause decomposition. Avoid all possible sources of ignition.

Incompatible Materials: Avoid contact with strong oxidizing agents and strong reducing agents.

Hazardous Decomposition Products: Not anticipated under normal conditions of use.

SECTION 11: Toxicological Information

Information on Toxicological Effects

Acute Toxicity	Hazard	Additional Information	LC50/LD50 Data
Inhalation	Unlikely to be harmful		>5 mg/L (mist, estimated)
Dermal	Unlikely to be harmful		>2 g/kg (estimated)
Oral	Unlikely to be harmful		>5 g/kg (estimated)

Likely Routes of Exposure: Inhalation, eye contact, skin contact

Aspiration Hazard: Not expected to be an aspiration hazard

Skin Corrosion/Irritation: Not expected to be irritating. Repeated exposure may cause skin dryness or cracking

Serious Eye Damage/Irritation: Not expected to be irritating

Skin Sensitization: No information available on the mixture, however none of the components have been classified for skin sensitization (or are below the concentration threshold for classification)

Respiratory Sensitization: No information available

Specific Target Organ Toxicity (Single Exposure): Not expected to cause organ effects from single exposure

Specific Target Organ Toxicity (Repeated Exposure): Not expected to cause organ effects from repeated exposure

Carcinogenicity: No information available on the mixture, however none of the components have been classified for carcinogenicity (or are below the concentration threshold for classification)

Germ Cell Mutagenicity: No information available on the mixture, however none of the components have been classified for germ cell mutagenicity (or are below the concentration threshold for classification)

Reproductive Toxicity: No information available on the mixture, however none of the components have been classified for reproductive toxicity (or are below the concentration threshold for classification)

Information on Toxicological Effects of Components

Distillates, petroleum, hydrotreated heavy paraffinic

Carcinogenicity: This oil has been highly refined by a variety of process to reduce aromatics and improve performance characteristics. It meets the IP-346 criteria of less than 3 percent PAH's and is not considered a carcinogen by the International Agency for Research on Cancer.

SECTION 12: Ecological Information

GHS Classification: No classified hazards

Toxicity: All acute aquatic toxicity studies on samples of lubricant base oils show acute toxicity values greater than 100 mg/L for invertebrates, algae, and fish. These tests were carried out on water accommodated fractions and the results are consistent with the predicted aquatic toxicity of these substances based on their hydrocarbon compositions.

Persistence and Degradability: The hydrocarbons in this material are not readily biodegradable, but since they can be degraded by microorganisms, they are regarded as inherently biodegradable.

Bioaccumulative Potential: Log Kow values measured for the hydrocarbon components of this material are greater than 5.3, and therefore regarded as having the potential to bioaccumulate. In practice, metabolic processes may reduce bioconcentration.

Mobility in Soil: Volatilization to air is not expected to be a significant fate process due to the low vapor pressure of this material. In water, base oils will float and spread over the surface at a rate dependent on viscosity. There will be significant removal of hydrocarbons from the water by sediment absorption. In soil and sediment, hydrocarbon components will show low mobility with absorption to sediments being the predominant physical process. The main process is expected to be slow biodegradation of the hydrocarbon constituents in soil and sediment.

Other Adverse Effects: None anticipated.

SECTION 13: Disposal Considerations

The generator of a waste is always responsible for making proper hazardous waste determinations and needs to consider state and local requirements in addition to federal regulations. This material, if discarded as produced, would not be a federally regulated RCRA "listed" hazardous waste and is not believed to exhibit characteristics of hazardous waste. See Sections 7 and 8 for information on handling, storage and personal protection and Section 9 for physical/chemical properties. It is possible that the material as produced contains constituents which are not required to be listed in the SDS but could affect the hazardous waste determination. Additionally, use which results in chemical or physical change of this material could subject it to regulation as a hazardous waste. This material under most intended uses would become "Used Oil" due to contamination by physical or chemical impurities. Whenever possible, Recycle used oil in accordance with applicable federal and state or local regulations. Container contents should be completely used, and containers should be emptied prior to discard.

SECTION 14: Transport Information

U.S. Department of Transportation (DOT)

UN Number:	Not regulated
UN Proper Shipping Name:	None
Transport Hazard Class(es):	None
Packing Group:	None
Environmental Hazards:	This product does not meet the DOT/UN/IMDG/IMO criteria of a marine pollutant
Special Precautions for User:	If shipped by land in a packaging having capacity of 3,500 gallons or more, the provisions of 49 CFR, Part 130 apply (contains oil).

Transport in Bulk according to Annex II of MARPOL 73/78 and the IBC Code: Not applicable

SECTION 15: Regulatory Information

CERCLA/SARA – Section 302: Extremely Hazardous Substances and TPQs (in pounds)

This material does not contain any chemicals subject to the reporting requirements of SARA 302 and 40 CFR 372.

CERCLA/SARA – Section 311/312 (Title III Hazard Categories)

Should this product meet EPCRA 311/312 Tier reporting criteria at 40 CFR 370, refer to Section 2 of this SDS for appropriate classifications.

CERCLA/SARA – Section 313 and 40 CFR 372

This material does not contain any chemicals subject to the reporting requirements of SARA 313 and 40 CFR 372.

EPA (CERCLA) Reportable Quantity (in pounds)

This material does not contain any chemicals with CERCLA Reportable Quantities.

California Proposition 65

This material does not contain any chemicals which are know to the State of California to cause cancer, birth defects, or other reproductive harm at concentrations that trigger the warning requirements of California Proposition 65.

International Inventories

All components are either listed on the US TSCA inventory or are not regulated under TSCA.

All components are either on the DSL or are exempt from DSL listing requirements.

SECTION 16: Other Information

Issue Date:	Previous Issue Date:	SDS Number	Status:
16-Apr-2018	23-Jun-2016	LBPH81776	FINAL

Revised Sections or Basis for Revision:

Exposure limits (Section 8); Regulatory information (Section 15)

Legend (pursuant to NOM-018-STPS-2015):

The information within is considered correct but is not exhaustive and will be used for guidance only, which is based on the current knowledge of the substance or mixture and is applicable to the appropriate safety precautions for the product.

Guide to Abbreviations:

ACGIH = American Conference of Governmental Industrial Hygienists; CASRN = Chemical Abstracts Service Registry Number; CEILING = Ceiling Limit (15 minutes); CERCLA = The Comprehensive Environmental Response, Compensation, and Liability Act; EPA = Environmental Protection Agency; GHS = Globally Harmonized System; HPR = Hazardous Products Regulations; IARC = International Agency for Research on Cancer; INSHT = National Institute for Health and Safety at Work; IOPC = International Oil Pollution Compensation; LEL = Lower Explosive Limit; NE = Not Established; NFPA = National Fire Protection Association; NTP = National Toxicology Program; OSHA = Occupational Safety and Health Administration; PEL = Permissible Exposure Limit (OSHA); SARA = Superfund Amendments and Reauthorization Act; STEL = Short Term Exposure Limit (15 minutes); TLV = Threshold Limit Value (ACGIH); TWA = Time Weighted Average (8 hours); UEL = Upper Explosive Limit; WHMIS = Worker Hazardous Materials Information System (Canada)

Disclaimer of Expressed and implied Warranties:

The information presented in this Safety Data Sheet is based on data believed to be accurate as of the date this Safety Data Sheet was prepared. HOWEVER, NO WARRANTY OF MERCHANTABILITY, FITNESS FOR ANY PARTICULAR PURPOSE, OR ANY OTHER WARRANTY IS EXPRESSED OR IS TO BE IMPLIED REGARDING THE ACCURACY OR COMPLETENESS OF THE INFORMATION PROVIDED ABOVE, THE RESULTS TO BE OBTAINED FROM THE USE OF THIS INFORMATION OR THE PRODUCT, THE SAFETY OF THIS PRODUCT, OR THE HAZARDS RELATED TO ITS USE. No responsibility is assumed for any damage or injury resulting from abnormal use or from any failure to adhere to recommended practices. The information provided above, and the product, are furnished on the condition that the person receiving them shall make their own determination as to the suitability of the product for their particular purpose and on the condition that they assume the risk of their use. In addition, no authorization is given nor implied to practice any patented invention without a license.