

ROTTLER

EM45 CNC MACHINING CENTER MACHINE OPERATIONS MANUAL



MANUAL SECTIONS

INTRODUCTION

SAFETY

CONTROL DEFINITIONS

OPERATING INSTRUCTIONS

ORDERING PROCEDURE

Contact your regional Rottler sales rep for assistance in ordering optional equipment, replacement parts, or tooling.

If you are unable to contact your regional Rottler sales rep, call the factory at (253)-872-7050 and ask to speak to the parts sales specialist.

Have the following information on hand to expedite the ordering process:

1. Your name, business name, and contact number
2. Customer number, or your billing address if you do not have a customer number
3. Shipping address if different from the billing address
4. Machine model and serial number
5. Part number and description of the item(s) to order
6. Preferred method of shipment

You may also contact us via e-mail with the above information. For customers within the U.S., send emails to parts@rottermfg.com, for customers outside of the U.S., use intlparts@rottermfg.com

In some cases you may be requested to send a photo of the part you are ordering if it is a replacement part or does not appear in our database.

If you are unsure which part you need to order, contact our service department, and ask to speak to one of our service consultants. They will assist you in determining which part(s) you require.

THERE IS A MINIMUM ORDER OF \$25.00

INTRODUCTION

Contents

Introduction	1-2
Description	1-3
Disclaimer	1-3
Limited Warranty	1-4
Online Documentation Access	1-5

Introduction

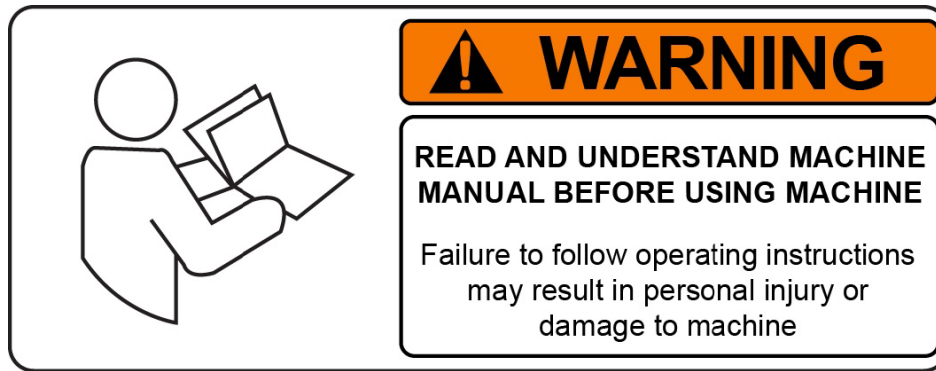

READ THE SAFETY SECTION OF THE OPERATIONS MANUAL BEFORE INSTALLING THE MACHINE. THOROUGHLY UNDERSTAND ALL SAFETY ISSUES BEFORE OPERATING MACHINE.

ATTENTION OWNER/BUSINESS MANAGER

To validate the warranty on your new Rottler machine, please be sure to sign and complete the “Installation Report” located in this manual.

We suggest that the new user(s) of the EM45 read the “Control Definitions” section of the Operations Manual to understand how the machine operates.

The “Operating Instructions” section of the Operations Manual should be read in order to familiarize the user with the actual button pushing sequences required to carry out a job. These sections in the manual should be considered an introduction. As the operator(s) of the EM45 series machine gain experience with using the different functions of the machine, complicated setups and programs will make more sense.

The Maintenance and Parts Manual contains information on part number references and routine machine maintenance. The operator(s) should read and become familiar with these areas as well.

Description

The model EM45 machine is a precision, single point boring, and high-speed surfacing unit. It can be equipped with tooling and accessories for surfacing and re-boring most small to medium gas and diesel engine blocks, both in-line and V-type.

EM45 machines can be easily tooled to machine a wide range of engines, including European and Asian engines. It can also be easily adapted to perform other boring and surfacing operations.

The machine is designed to maintain alignment of cylinder bores, cylinder heads, and deck surfaces to the pan rails and main bearing bore locations, as was done in the original factory machining. This overcomes the many inaccuracies and out-of-alignment problems associated with clamping portable boring bars to the cylinder head surface of blocks.

Convenient controls, fast block clamping, and precise 3-axis CNC positioning means considerable savings in floor-to-floor time and operator involvement.

Change over or resetting time required to set up V-type or In-line engines is minimized, making this machine highly suited to shops where engines cannot be run through in model lots.

All feeds and rapid travels are power operated and controlled from the control panel.

Disclaimer

The EM45 Manual (henceforth to be referred to as the "Manual") is proprietary to Rottler Manufacturing LLC. ("Rottler Manufacturing") and no ownership rights are hereby transferred. No part of the Manual shall be used, reproduced, translated, converted, adapted, stored in a retrieval system, communicated or transmitted by any means, for any commercial purpose, including without limitation, sale, resale, license, rental or lease, without the prior express written consent of Rottler Manufacturing.

Rottler Manufacturing does not make any representations, warranties, or guarantees, express or implied, as to the accuracy or completeness of the Manual. Users must be aware that updates and amendments will be made from time to time to the Manual. It is the user's responsibility to determine whether there have been any such updates or amendments. Neither Rottler Manufacturing nor any of its directors, officers, employees, or agents shall not be liable in any manner whatsoever to any person for any loss, damage, injury, liability, cost, or expense of any nature, including without limitation incidental, special, direct or consequential damages arising out of or in connection with the use of the Manual.

Rottler Manufacturing and its employees or representatives are not responsible for any information regarding final specifications of any workpiece that is created as a final product when using Rottler equipment. It is the responsibility of the end user of Rottler equipment to determine the final dimensions and finishes of the workpiece that they are working on. Any information regarding final dimensions and finishes that appears in any Rottler literature or that is expressed by anyone representing Rottler is to be regarded as general information to help with the demonstration of or for operator training of Rottler equipment.

Limited Warranty

Rottler Manufacturing Company Model EM45 parts and equipment is warranted as to materials and workmanship. This limited warranty remains in effect for one year from the date of installation or two years from the date of the original shipment from Rottler or whichever date occurs first. This only applies if the machine is owned and operated by the original purchaser and is operated and maintained as per the instructions in the manual. A machine is warranted only if the Installation Report has been properly executed by a certified installation person and received by Rottler at the time of actual installation.

The products are warranted upon delivery to conform to their published specifications and to be free from defects in material and workmanship under normal use for a period of one year from shipment. Should a product not be as warranted, Rottler's sole obligation shall be, at its option, to repair, correct or replace the product or to refund the amounts paid for the Product upon its return to a location designated by Rottler. No warranty shall extend to rapid wear Products (including tooling) or to Products which have been subject to misuse (including any use contrary to Rottler instructions), neglect, accident (including during shipment), improper handling or installation, or subject to any modification, repair or service not certified by Rottler. Rottler shall not be liable for any consequential, direct or indirect damages or for any other injury or loss. Buyer waives any right, beyond the foregoing warranty, to make a claim against Rottler. No warranty is provided for any Products not paid in full.

Merchandise cannot be returned to Rottler without prior approval. Customer must contact the Parts Department to get approval and to be issued a Return Goods Authorization number (**RGR#**). Merchandise authorized for return must be returned prepaid. If merchandise is returned with shipping charges collect, the actual amount of these charges may be deducted from any credit which may be due the customer. The **RGR #** assigned by the Parts Department should be written on the shipping label and must appear on a copy of the invoice(s) covering the original shipment. This invoice copy must be included in the box with the parts. Shipment must contain **ONLY** those items on the **RGR** as approved for return. Merchandise must be received within 10 days of the date of **RGR** or the **RGR** will be canceled. All returned merchandise may be subject to a 20% restocking fee on under \$1,000.00 amount or 10% on any items over \$1,000.00. Parts or tooling over 30 days old are considered as customer property and can only be returned with prior approval from Rottler Corporation Management.

The issuance of a **RGR DOES NOT** guarantee credit - it is only authorization for the return of the goods. Credit for return merchandise is at the sole discretion of Rottler. Credit will be issued only after inspection of returned goods.

Tools proven to be defective within the warranty period will be repaired or replaced at the factory's option.

We accept no responsibility for defects caused by external damage, wear, abuse, or misuse, nor do we accept any obligation to provide compensation for direct or indirect costs in connection with cases covered by the warranty.

Online Documentation Access

Online documentation for machines and optional equipment, including manuals and catalogs, can be accessed at the Rottler website. To access documentation, open your browser and navigate to <https://www.rottlermfg.com>

Scroll to the bottom of the page and under the “Owner Resources” title, click the type of documentation you want to access.

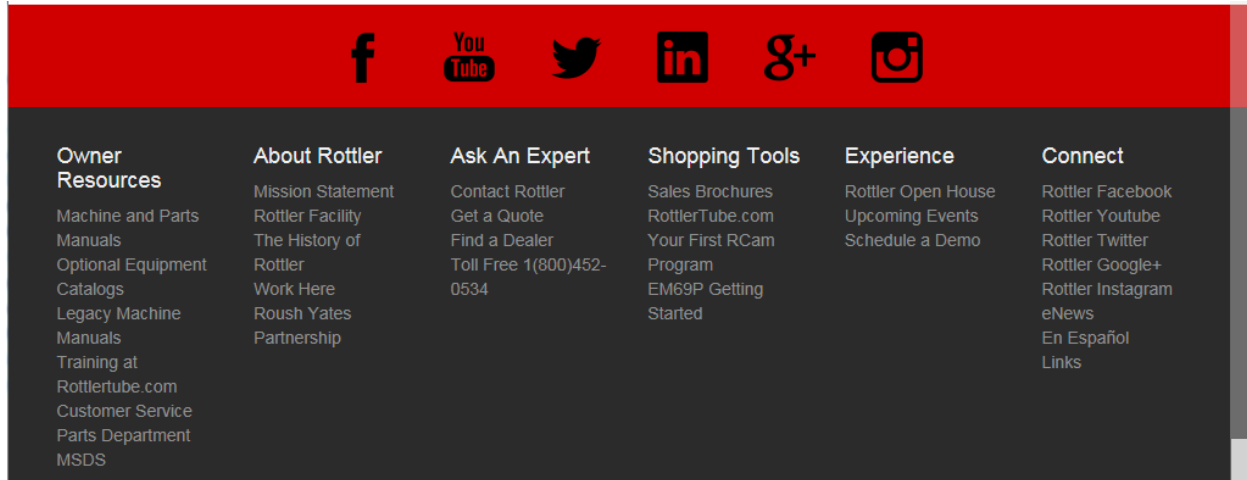

If a log-in window pops up asking for a username and password, fill in the blanks as shown:

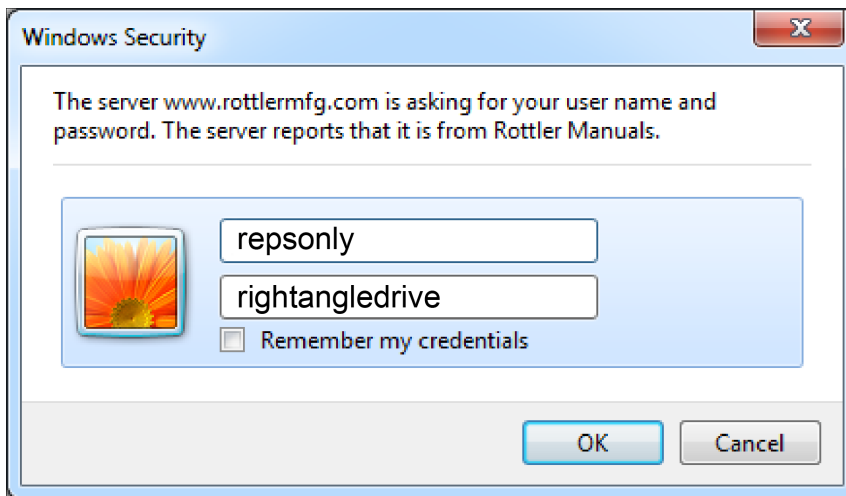

SAFETY

Contents

Safety Information	2-2
Safety Instructions for Machine Use.....	2-2
Electrical Power	2-4
Machine Operator	2-6
Emergency Procedure.....	2-7
Computer and Controller System Safety	2-7
Electrical Safety Features of Rottler DM Controlled Machines	2-8

Safety Information

For your own safety, read this Instruction Manual before operating this Machine.

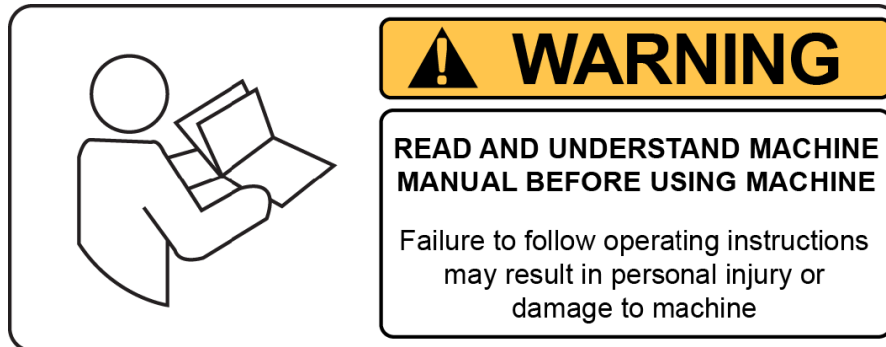

This is the safety alert symbol. It is used to alert you to potential personal injury hazards. Obey all safety messages that follow this symbol to avoid possible injury or death.



DANGER

DANGER indicates an imminently hazardous situation which, if not avoided, will result in death or serious injury.



WARNING

WARNING indicates a potentially hazardous situation which, if not avoided, could result in serious injury.



CAUTION

CAUTION indicates a potentially hazardous situation which, if not avoided, may result in minor or moderate injury.

CAUTION

CAUTION used without the safety alert symbol indicates a potentially hazardous situation which, if not avoided, may result in property damage.

Safety Instructions for Machine Use



WARNING

This machine is capable of causing severe bodily injury

ONLY A QUALIFIED, EXPERIENCED OPERATOR SHOULD OPERATE THIS MACHINE. NEVER ALLOW UNSUPERVISED OR UNTRAINED PERSONNEL TO OPERATE THE MACHINE. Make sure any instructions you give in regards to machine operation are approved, correct, safe, and clearly understood. Untrained personnel present a hazard to themselves and the machine. Improper operation will void the warranty.

KEEP GUARDS IN PLACE and in proper working order. If equipped with doors, they must be in the closed position when the machine is in operation.



KEEP WORK AREA CLEAN. Cluttered areas and benches invite accidents.

KEEP CHILDREN AND VISITORS AWAY. All children and visitors should be kept a safe distance from work area.

WEAR THE PROPER APPAREL. DO NOT wear loose clothing, gloves, rings, bracelets, or other jewelry which may get caught in moving parts. Non-Slip footwear is recommended. Wear protective hair covering to contain long hair.

ALWAYS USE SAFETY GLASSES. Also use face or dust mask if cutting operation is dusty. Everyday eyeglasses only have impact resistant lenses, they are NOT safety glasses.



DO NOT OVER-REACH. Keep proper footing and balance at all times.

USE THE RECOMMENDED ACCESSORIES. Consult the manual for recommended accessories. The use of improper accessories may cause risk of injury.

CHECK DAMAGED PARTS. Before further use of the machine, a guard or other part that is damaged should be checked to determine that it will operate properly and perform its intended function. Check for alignment of moving parts, breakage of parts, mounting, and other conditions that may affect its operation. A guard or other part that is damaged should be properly repaired or replaced.

NEVER OPERATE A MACHINE WHEN TIRED, OR UNDER THE INFLUENCE OF DRUGS OR ALCOHOL. Full mental alertness is required at all times when running a machine.

IF AT ANY TIME YOU ARE EXPERIENCING DIFFICULTIES performing the intended operation, stop using the machine! Then contact our service department or ask a qualified expert how the operation should be performed.

DO NOT MODIFY OR ALTER THIS EQUIPMENT in any way. If modifications are deemed necessary, all such requests must be approved and/or handled by Rottler Manufacturing. Unauthorized modifications could cause injury and/or damage to machine and will void the warranty.

SAFETY DECALS SHOULD NEVER BE REMOVED. They are there to convey important safety information and warn of potential hazards.

ALL LOCAL SAFETY CODES AND REGULATIONS should be followed when installing this machine.

ONLY QUALIFIED PERSONAL should perform service on the electrical and control systems

When boring, the machine is capable of throwing metal chips over 10- feet from the cutting area. Always use the guards. Eye protection must be worn at all times by the operator and all other personnel around the machine.



CAUTION No list of safety guidelines can be complete. Every piece of shop equipment is different. Always consider safety first as it applies to your individual working conditions. Use this and other machinery with caution and respect. Failure to follow guidelines could result in serious personal injury, damage to equipment, or poor work results.

Electrical Power

THIS MACHINE IS AUTOMATICALLY CONTROLLED AND MAY START AT ANY TIME.

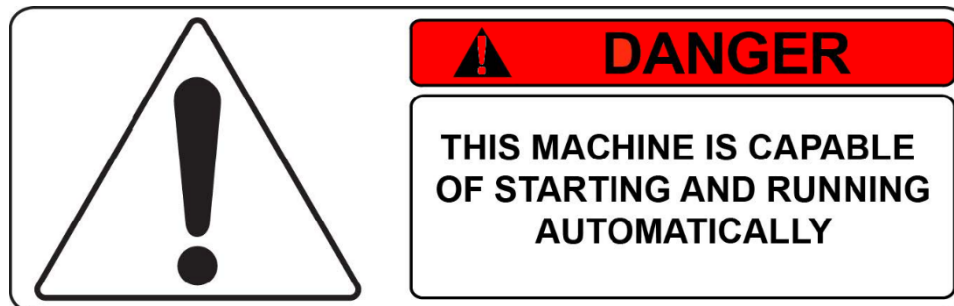

All electrical power should be removed from the machine before opening the rear electrical enclosure.

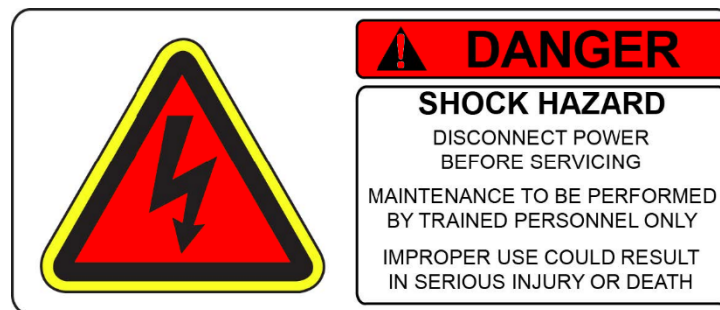

In the event of an electrical short, grounding reduces the risk of electric shock by providing a path of least resistance to disperse electric current.

Electrocution or a fire can result if the machine is not grounded correctly. Make sure the ground is connected in accordance with this manual. **DO NOT** operate the machine if it is not grounded.

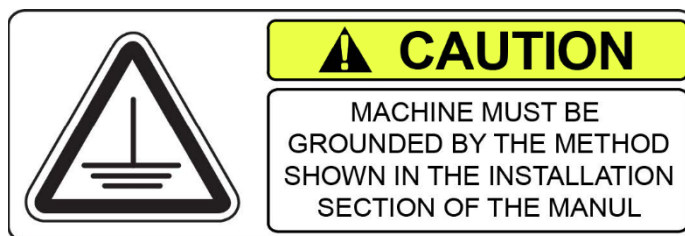

CAUTION No single list of electrical guidelines can be comprehensive for all shop environments. Operating this machinery may require additional electrical upgrades specific to your shop environment. It is your responsibility to make sure your electrical system complies with all local codes and ordinances.

WARNING This machine operates under computerized control and, like all computerized equipment, is susceptible to extraneous electrical impulses internally or externally produced. The machine may make moves out of the operator's control at any time. The operator should work in and around the machine with caution at all times.

The operator and nearby personnel should be familiar with the location and operation of the Emergency Stop Button.

Make sure all electrical equipment has the proper overload protection. ***This machine should have a fully isolated power supply*** to prevent damage and uncontrolled movement of the machine. If this machine is on the same power lines that are running to other electrical equipment (grinders, welders, and other AC motors) electrical noise can be induced into this machine's electrical system. Electrical noise can cause the controller to see false signals to move. Not supplying a fully isolated supply to the machine may void factory warranty. Refer to the Power Supply section located in the Installation section for voltage and amperage requirements of this machine.

Machine Operator

The operator of this machine should be a skilled machinist craftsman who is well versed in the caution, care, and knowledge required to safely operate metal cutting tools.

If the operator is not a skilled machinist, he/she must pay strict attention to the Operating Instructions outlined in this manual and get instruction from a qualified machinist in both production and operation of this machine.

This machine has the following areas of exposed moving parts that you must train yourself to respect and stay away from when they are in motion:

Cutting Tool Area – Any operation involving hands in the cutter head area, such as inspection or alignment of the cutter head or tools, tool insertion and removal, cutter head changes, and size checking, etc. requires the spindle to be completely stopped.



Machining – Eye protection must be worn during all operations of the machine. Hands must be kept completely away from the cutter head. All chip guards must be in position during machine operations.



CAUTION Work Loading and Unloading – Carefully develop handling methods of loading and unloading work pieces so that no injury can result if hoist equipment or lift connection should fail. Periodically check lift components for damage that may cause failure.

CAUTION **Machine Maintenance** – Any machine adjustment, maintenance or parts replacement absolutely requires a complete power disconnection from the machine.

Emergency Procedure

Assuming one of the following has occurred: tool bit set completely off size, work piece not clamped, spindle is not properly centered, and these mistakes will become obvious the minute the cut starts **PRESS THE EMERGENCY STOP BUTTON IMMEDIATELY!** (on the front control panel)

Find out what the problem is, return the spindle to its up position without causing more damage. To restart the machine, turn the Emergency Stop Button CW until the button pops out

Be alert to quickly stop the machine in the event of a serious disruption of the boring process either at the top or bottom of the bores.

REMEMBER, metal cutting tools have the speed and torque to severely injure any part of the human body exposed to them.

Computer and Controller System Safety

The computer and controller are located in the main rear electrical enclosure. This unit is a full computer, running Windows 10 operating system. Contact the factory if more information on the computer system is required.

IMPORTANT

The computer in this machine has the ability to connect to the Internet via Ethernet or Wireless using a USB wireless (Wi-Fi) adapter. Updating the Rottler software should **ONLY** be done when directed to do so by a Rottler service technician. Updating Rottler Software when not directed by Rottler personnel will result in a non-operational machine.

The machine should be hooked up to the Internet anytime it is on. The software on the machine will automatically connect to our server to send back useful information on machine status.

Any IT personnel should **ALWAYS** get approval from Rottler before doing ANYTHING on the computer.



DANGER

This machine is capable of causing severe injury or death. Doing any of the following without Rottler's direct consent may cause severe injury or death.



WARNING

Do not attempt to install any USB devices in the PCI ports (the group of 16 USB ports located on the computer case). These ports have high voltage and any attempt to connect a USB device in these ports will result in destruction of that device. There is also the possibility of damage to the computer system of the machine.

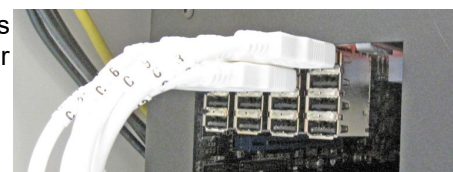

IMPORTANT

Downloading any program or changing any Rottler or Computer settings may cause the machine and/or software to become unstable. **DO NOT** install ANY screen saver, Anti-Virus, Spyware or any type of Security software on the computer. This could create a hazardous environment for the operator and personnel around the machine. Performing any of the above will also result in the machine warranty being NULL and VOID.

IMPORTANT

DO NOT connect any type of external hardware to the computer via USB or any other means. Do not install any type of Device Driver. This could create a hazardous environment for the operator and personnel around the machine. Performing any of the above will also result in the machine warranty being NULL and VOID.

Electrical Safety Features Of Rottler DM Controlled Machines

All Rottler machines that use the DM operational control system are designed to comply with all applicable safety standards. This includes but is not limited to the following systems:

1. Current sensors in all motor control panels.
2. Thermal sensors in all motors and motor controls.
3. Electrical breakers to prevent voltage surges and spikes from reaching electrical system.
4. Electrical lockout on main electrical enclosure.
5. E-Stop that shuts down all operational systems in an event of an emergency.

All thermal and current limits for motors and motor controls are preset at the factory. In the event that any of those parameters are exceeded during operation of the machine, the machine control system will shut down the machine and a warning of the specific fault will appear on the control screen.

CONTROL DEFINITIONS

Contents

Control Definitions.....	3-4
Computer and Controller System Safety for DM Controlled Machines	3-4
Master Power On/Off Switch.....	3-4
Initialization Screen.....	3-5
General Information	3-5
Home	3-5
Change Tool.....	3-5
Program Select.....	3-5
New	3-6
Options	3-6
Delete	3-6
Mode Select	3-7
New	3-7
Std (Standard) Setup	3-8
Options	3-8
Delete	3-8
Basic Machine Controls	3-8
Cylinder Bore, General Bore, 3-Axis (no Tool Changer).....	3-10
Set Zero Tab.....	3-10
Actual Position.....	3-10
Velocity Override	3-10
Zero Buttons	3-10
Handwheel Buttons.....	3-10
Spindle Start	3-10
CW and CCW Creep.....	3-11
Jog Buttons.....	3-11
Move To.....	3-11
Move To Zeros.....	3-11
CW and CCW Index.....	3-11
Using SSV (Spindle Speed Variance).....	3-12
Setting Spindle Index	3-12
Probe Auto Center	3-12

Vertical Stops Tab	3-13
Horizontal Offset for Honing.....	3-13
Left and Right Locations Tab	3-14
Cylinder Bore – Bore Locations.....	3-14
Blueprint	3-14
Move Buttons.....	3-14
Bore Buttons	3-15
Indicated	3-15
Set Buttons	3-15
Copy Values	3-15
Difference	3-15
Bore Left and Right.....	3-15
Probing	3-16
Probe Buttons	3-16
Probe Left or Right.....	3-16
Probe Diameter.....	3-16
Probing for the Mill Cycle	3-19
Table of Tools for Milling.....	3-21
Assigning Tools	3-21
Left Deck Probe.....	3-21
Right Deck Probe.....	3-21
Auto Probing.....	3-22
Lifter Bore	3-21
Cylinder Bore, 4th Axis	3-21
Set Zero Tab.....	3-21
Jog Controls	3-21
4 th Axis Degree and Move.....	3-21
4 th Axis Brake.....	3-21
Light Clamp	3-22
Full Clamp	3-22
Retract.....	3-22
Table of Tools	3-23
Table of Tools General Information.....	3-23
Accessing Table of Tools	3-23
Add Tool	3-24
Remove Tool	3-24

Set Active Tool.....3-25

Setting Tool Offsets3-26

Z Location from Zero.....3-27

Z Touch-off Height3-27

Add Tool Radius?3-27

Applying Table of Tools to Rottler Programs3-27

Fixture Select.....3-27

Control Definitions

The purpose of this chapter is to define the function of the buttons throughout the various screens. Certain button functions may not make sense right away in this chapter. As the operator reads through the Operating Instructions chapter of this manual, the function of these buttons will become clear.

Computer and Controller System Safety for DM Controlled Machines

The computer and controller are located in the main rear electrical enclosure. This unit is a full computer, running Windows operating system. Contact the factory if more information on the computer system is required.

IMPORTANT: The computer in this machine has the ability to connect to the Internet via Ethernet or Wireless using a USB wireless (Wi-Fi) adapter. Updating the Rottler software should **ONLY** be done when directed to do so by a Rottler service technician. Updating Rottler Software when not directed by Rottler personnel could result in a non-operational machine.

It is recommended that the machine be hooked up to the Internet anytime it is on. The software on the machine will automatically connect to our server to send back useful information on machine status. It will also record performance parameters that will be used to evaluate any occurrence of a malfunction.

The Auto Update for the Windows Firewall (Security) and Windows Defender (Anti-Virus) is turned on. The computer will automatically download the updates and then install them when the computer is shut down every Friday night.

Any IT personnel should **ALWAYS** get approval from Rottler before doing **ANYTHING** on the computer.

 **WARNING** Downloading ANY program from the Internet or by other means when not directed by Rottler is prohibited and will result in the machine warranty being NULL and VOID.

 **WARNING** Downloading any program or changing any Rottler or Computer settings may cause the machine and/or software to become unstable. **DO NOT** install ANY screen saver, Anti-Virus, Spyware or any type of Security software on the computer. This could create a hazardous environment for the operator and personnel around the machine. Performing any of the above will also result in the machine warranty being NULL and VOID.

Master Power On/Off Switch

This switch is located on the main electrical control enclosure on the right-hand side of the machine.

When first applying power to the machine the computer will need to boot up. Be patient, it will take several minutes to complete booting. The Rottler program will not automatically start. Double tap the Rottler_WPF icon on the screen to start Rottler.

When turning the main power to the machine off there is a specific procedure to follow so as not to damage the computer. The computer must shut down its internal systems before main power is removed from it.

Press the “Start” button in the left-hand side of the Start Bar. This will bring up the “Start Menu”. Press the “Shutdown” line at the bottom of the Start Menu. This will bring up a Pop-Up menu, make sure that “shut down computer” is selected and press “OK”.

This will shut down the computer. It is now OK to turn Main Power off to the machine.

Initialization Screen

When the EM45 is powered up, the Rottler program will not automatically start. It may take several minutes for the computer to power. Start the Rottler program by double tapping the Rottler_WPF icon on the desktop. Once the program is started, the Rottler Program Select will appear.

NOTE: Do not push any buttons or icons on the screen before the Rottler program starts or an error may be caused on the computer.

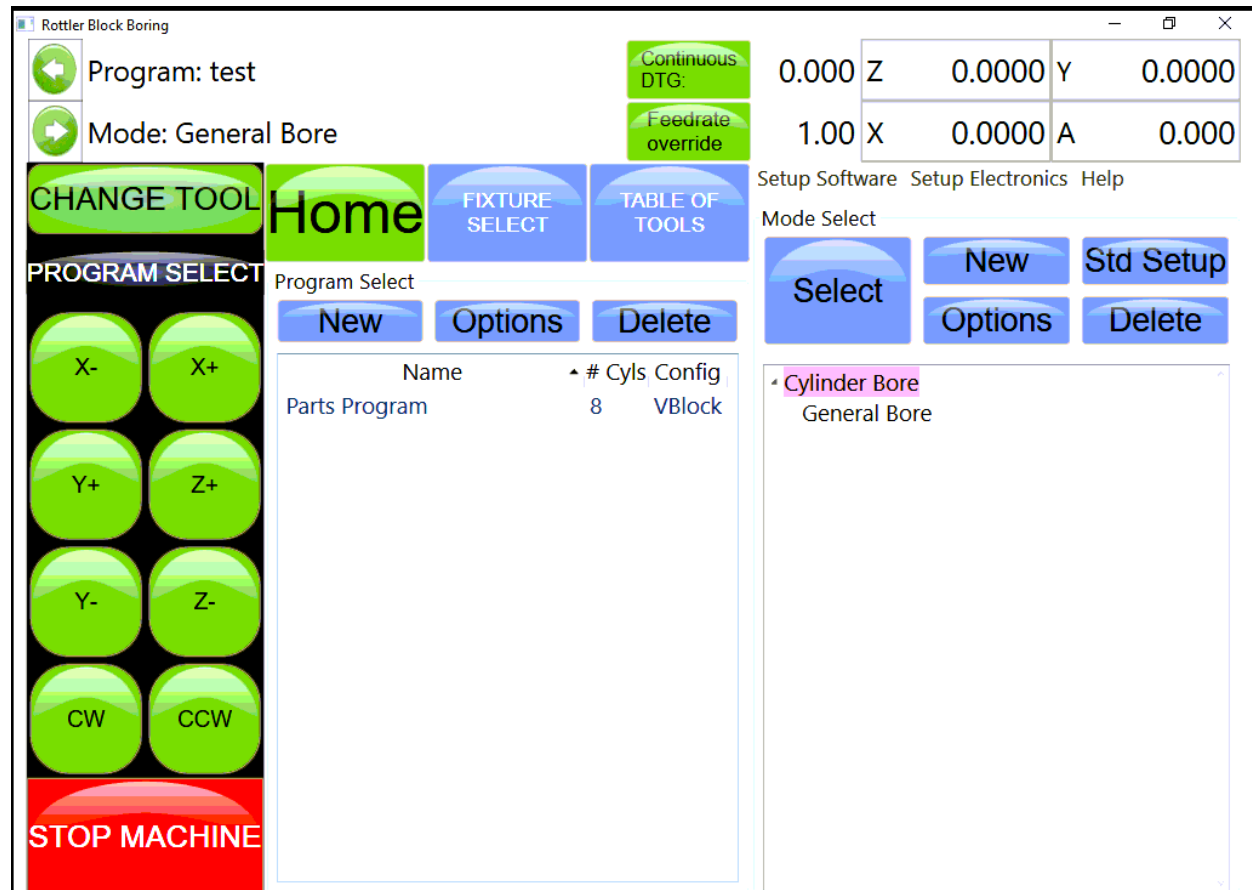

General Information

The Rottler software operates on a Block Model format. You select or create the block you are working with. Then select or create an operation to be performed on that block.

Home

Pressing this button will cause the machine to run a self-check on the electronics. The machine MUST be homed after it is turned on.

Program Select

This is the left section of the screen. This is where you create and select blocks you will be working with.

Change Tool

Pressing the CHANGE TOOL button near the upper left will cause the tool to release from the machine, it will ask you if you really want to change it before it actually releases the tool.

WARNING *If there is a tool in the spindle do not press Yes unless holding the tool, or the tool will drop!*

New

Pressing this in the Upper level will cause a dialog box to appear. Here is where you name and configure the block, the number of cylinders and Inline or V Block.

New Block Options Window

Block Name:

Number of Cylinders:

of intake valves per cylinder

of exhaust valves per cylinder

VBlock

Share Vertical Zero in Group

Share All Values in Groups

Pressing OK will result in the Block Model being inserted into the left hand side of the screen.

Rottler Block Boring

Program: Test

Mode: General Bore

Continuous DTG: 0.000 Z 0.000 Y 0.000

Feedrate override: 1.00 X 0.000 A 0.000

Setup Software Setup Electronics Help

Mode Select

Change TOOL Home FIXTURE SELECT TABLE OF TOOLS

PROGRAM SELECT

Program Select

New Options Delete

Name	# Cyls	Config
Chev 350	8	VBlock

Select New Std Setup

Options Delete

E-STOP IN

Options

This will bring up the same dialog box as described above if any of the information needs to be changed.

Delete

This will delete whatever block program is selected. A dialog box will appear to ask you if you want that program deleted.

Mode Select

This is the right-hand section of the screen. Here you create or select operations to be performed on the selected block. This area will be blank when you first create a block.

You can create only certain modes for use on a block, or use a standard set up that inserts all modes available. You can also create a new mode and rename it for a specific use.

New

Pressing this button will bring up a dialog box with Rottler standard operations.

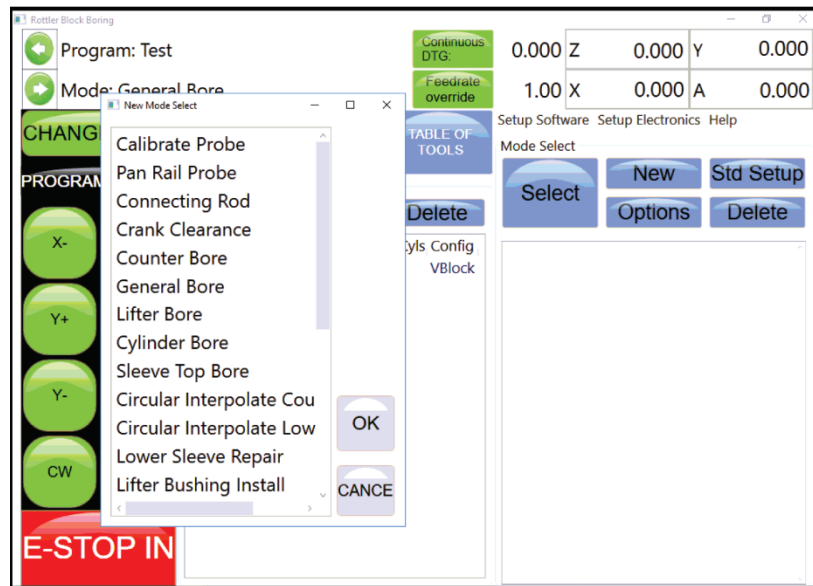

Select the operation you want to create and press “OK”. This will place a general bore operation under the cylinder bore mode in the right-hand section.



To enter General Bore mode, highlight it and press “Select”. This will take you to the operation screens that will be described later.

Std (Standard) Setup

Pressing this button will insert all the Rottler operations into the right-hand section automatically.

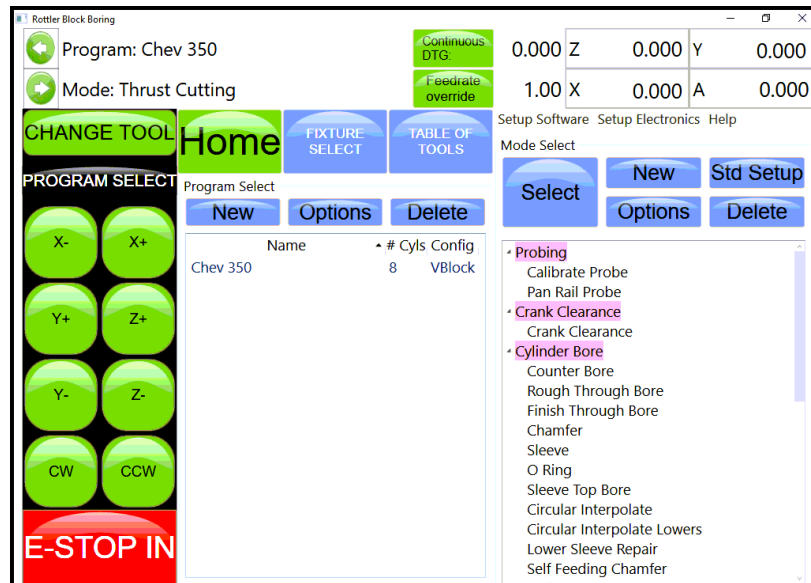

Use the slide bar on the right-hand side to scroll through all the operations.

Options

Press this button to bring up a dialog box to allow positive numbers to be entered in the horizontal stops. Most all programs are from left to right, the farther right you go the larger the negative number. However, if a different zero point is used a positive number may be needed. For example, if you zero on the first cylinder on the left bank of a block and then "roll it over" the first cylinder is farther to the right than the zero position. Which would be a positive number.

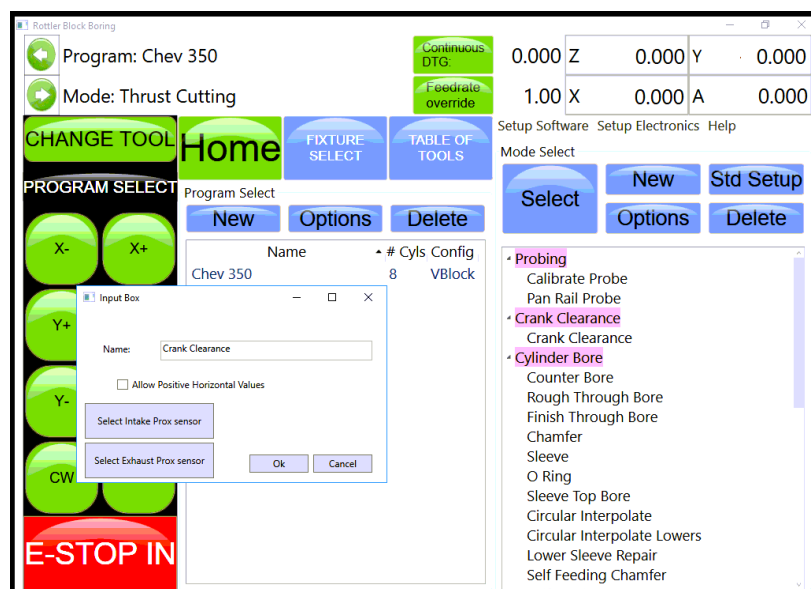

Delete

This will delete the selected Mode. It will ask you if you want this mode deleted before deleting it.

NOTE: Once the control definition for a particular button has been discussed it will not be repeated in the different modes of operation. Only new buttons or buttons with a different function will be discussed in different modes.

For these descriptions, the Tool# and Probe # are not being used. They will be described later in this chapter.

Basic Machine Controls

The image shows a screenshot of a machine control interface with several annotated buttons and displays. On the left, a yellow 'Fixture' button is above a display showing 'Actual Position' with '0.0000' for X, Y, and Z axes. A red box highlights these values with the text 'Shows the linear position of the axis'. Below this is a 'SPINDLE' button and a display showing '36.04' with the text 'Shows the Position of the spindle in 0-360°'. A green arrow points to the SPINDLE button with the text 'Double click to zero the axis'. On the right, a 'Handwheel' section has three buttons for '0.010', '0.001', and '0.0001', with a blue arrow pointing to them and the text 'Click to move handwheel'. Next to them is a green 'Move To' button with a purple arrow pointing to it and the text 'Click to move to a position, a box that lets you enter the position will pop up'. Below this is a 'Notes' section with a 'Tool #:0' button (red arrow, 'Click to select the correct tool') and a 'Set Active' button (black arrow, 'Used for ATC and setting proper tool offsets').

Cylinder Bore, General Bore, 3 Axis (No Tool Changer)

Each buttons function will be described in this section. In the different MODES, the same buttons will not be described again.

Set Zero Tab

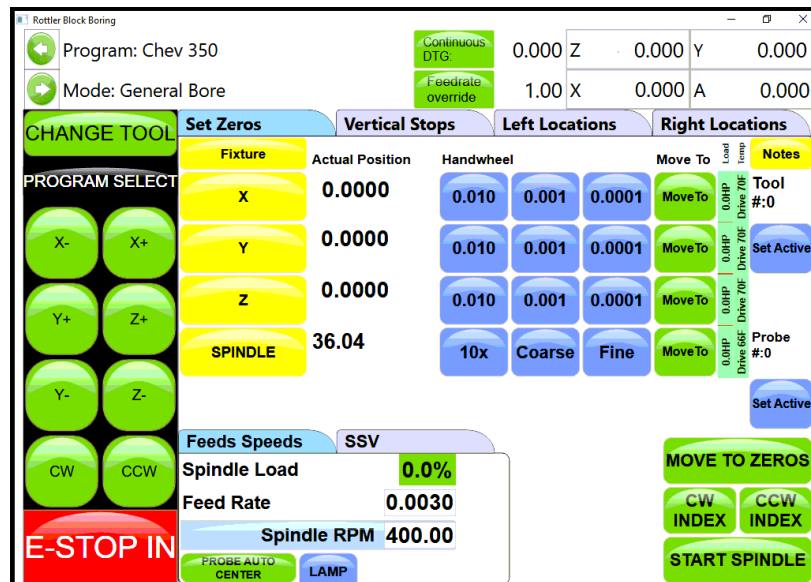

Actual Position

These are a numerical display showing the actual distance the axes are away from where they have been zeroed.

Velocity Override

The Velocity override is displayed in the upper left of the Actual Position display. The default is 100% of the programmed Feed Rate. When operating... turning the handwheel Counterclockwise will override the axis rapid travel and feed rate 100 and 0% when in an automatic cycle.

Zero Buttons

These buttons will erase the actual position display of their associated axis and reset the displayed value to zero.

Handwheel Buttons

These buttons will activate their associated axis for use with the handwheel. The left button of each axis will move the machine in .010" per detent, the middle button .010" per detent and the right .0001" per detent of the handwheel. Pressing any of the axis Jog buttons will disengage the handwheel.

Spindle Start

This button will start the spindle at the RPM that is specified on the Auto Bore Cycle tab. Once the button has been pressed and the spindle is running the button will turn red and read Spindle Stop. Pressing the button again will stop the spindle and cause the button to go back to green.

CW and CCW Creep

These buttons will cause the spindle to rotate slowly CW or CCW direction. The spindle will continue to rotate as long as the button is pressed. The speed at which the spindle will rotate is set in the Machine Parameters and should not be changed unless instructed to do so by the factory.

Jog Buttons

These buttons control the rapid travel of the Vertical, Horizontal and In/Out axis. Pressing these buttons will allow you to move the machine through all ranges of its travel unobstructed. If the spindle is turned on these buttons become feed buttons and the machine will feed in whatever direction you have pressed. The rate at which the machine will feed is determined by the value set in the Auto Bore Cycle tab. When in rapid travel, these buttons are momentary contact and you will have to keep them pressed to keep the machine moving. When the spindle is on, they are latching buttons and once they are pressed the travel will continue until they are pressed again.

Move to

Pressing these buttons will bring up a dialog box for the associated axis. Enter a value that you want the axis to move to and press ENTER. That axis will then move to that position. You can do multiple "Move To" at the same time. One after another.

Move To Zeros

Pressing this button will cause the vertical to move the zero position first. The in/out and horizontal will move after the vertical has moved to zeros.

CW and CCW Index

Pressing either of these buttons will cause the spindle to rotate to the index position. Index position is with the tool to the right as you are facing the machine.

Using SSV (Spindle Speed Variance)

Spindle Speed Variation (SSV) allows you to modify the spindle speed within a range causing it to continuously change. This changes the harmonic frequency of the machining, which can help in the appearance of chatter. Various issues can cause chatter: spindle speed, incorrect feeds, depth of cut, part rigidity, the type of part being machined, thin walls, or diameter-length ratio.



Checking enable SSV- will engage it for the machining process you are doing

Time per Cycle- each cycle is measured as a second.

RPM Variation- How much the rpm can vary up and down from what you set in the program

(NOTE: setting this too extreme can cause Spindle errors and spindle crashes.)

IMPORTANT

Setting Spindle Index

Any time the machine has been turned off the spindle index position must be set. Turn the spindle to the index position (tool holder facing to the right at 90 degrees from the operator). Then press the Zero button next to the spindle position read out. This will put a zero value in the display box.

This screen also shows the Spindle Load, programmed Feed Rate and Spindle RPM.

Probe Auto Center

The Probe is an option on the EM45 machine. When this button is pressed a single Probing routine will be run in the position the machine is currently at.

Vertical Stops Tab

This screen is used to set the Vertical stops the machine will use to bore a cylinder. There are four Vertical stops used on this screen plus two optional Lower Clearance stops.

If the machine is equipped with a probe there are two (2) additional stops, Probe Clearance and Probe Height.

The function of the Vertical stops will be defined in the Operating Instructions chapter in this manual. To enter any of the Vertical Stops press the Data box next to the Vertical stop you want to enter. A pop-up menu will appear. Press the desired numerical value and then press ENTER. The numerical data will then appear in the data box. You can also move the Vertical physically to the location you want the stop to be at and press the "SET" button next to the Data Box. This will take the current position from the Digital read out and insert it into the associated Data Box.

The screenshot shows the 'Vertical Stops' tab in the Rottler Block Boring software. The interface includes a top status bar with program and mode information, a left sidebar with tool and program selection buttons, and a main control area with various input fields and buttons.

Parameter	Value	Action
Block Clearance	1.2000	SET
Centering Height	0.7500	SET
Start Boring Height	0.1000	SET
Bottom of Bore	-6.5000	SET
Probe Clearance	0.0000	SET
Probing Height	0.0000	SET
Largest Probe Diameter	0.0000	
Start Offset Height	0.0000	SET
Horizontal Offset	0.0000	

Additional controls include checkboxes for 'X Offset for Honing', 'Washout Cycle', 'Coolant', and 'Stop and Index Spindle After Cycle'. A 'HANDWHEEL' section at the bottom allows for manual adjustments to the Z-axis with values of .010, .001, and .0001.

Horizontal Offset for Honing

There is often the need to machine out the "webbing" at the bottom of a cylinder to get the correct honing clearance. Checking the box next to "Horizontal Offset for Honing" will bring up an additional screen section on the lower right.

This is where you will set the amount, direction and speed the offset will cut.

This screenshot shows the 'Horizontal Offset for Honing' section of the software interface. It features a sub-section titled 'AFTER HORIZONTAL OFFSET' with a 'Horizontal Offset' field set to 0.0000 and a 'Change Speeds At Horizontal Offset' checkbox. Below this, there are 'Left Bank' and 'Right Bank' dropdown menus, both currently set to 'No Offset'.

Parameter	Value	Action
Block Clearance	1.2000	SET
Centering Height	0.7500	SET
Start Boring Height	0.1000	SET
Bottom of Bore	-6.5000	SET
Probe Clearance	0.0000	SET
Probing Height	0.0000	SET
Largest Probe Diameter	0.0000	
Start Offset Height	0.0000	SET
Horizontal Offset	0.0000	

The 'AFTER HORIZONTAL OFFSET' section includes a 'Horizontal Offset' field set to 0.0000 and a 'Change Speeds At Horizontal Offset' checkbox. Below this, there are 'Left Bank' and 'Right Bank' dropdown menus, both currently set to 'No Offset'.

Left and Right Locations Tab

This screen is used to set the Horizontal and In/Out stops the machine will use to bore a block. The number of In/Out and horizontal stop on this page will change with the block configuration i.e V6, V8 or inline.

The function of the Horizontal and In/Out stops will be defined in the Operating Instructions chapter of this manual.

To enter any of the Horizontal and In/Out stops press the Data box next to the Horizontal or In/Out stop you want to enter. A pop-up menu will appear. Press the desired numerical value and then press OK. The numerical data will then appear in the data box

Cylinder Bore – Bore Locations

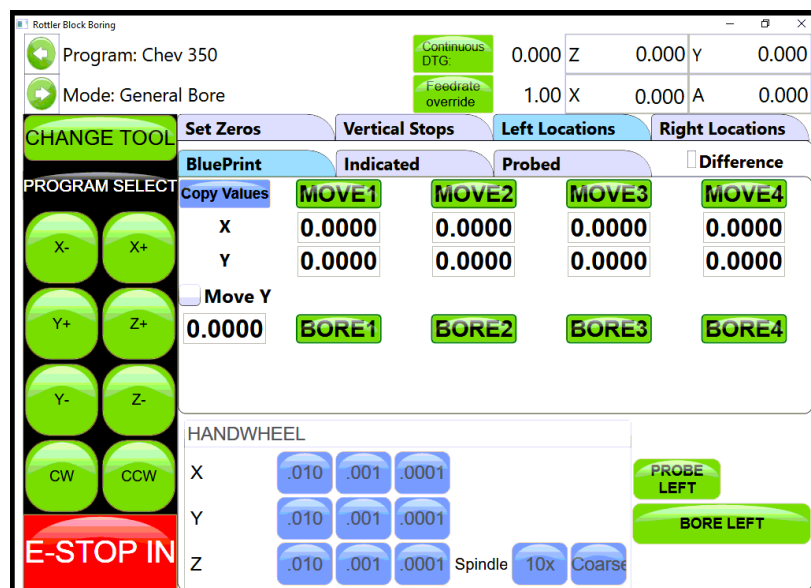

There are three (3) different modes you can operate the machine in on these screens, Blueprint, Indicated and Probing.

Blueprint

This mode of operation allows you to enter specific values for the bore locations from a blueprint type document.

It is helpful to have the blueprint numbers entered on this screen even if you are not going to bore to the blueprint locations on a particular block. They help to set the general area of the bore if you are manually centering (indicating) or probing the block.

Move Buttons

When pressed, these buttons will move the machine, under power, to the Horizontal and In/Out positions shown in the data boxes below the Move button. The Vertical will move to the Clearance height before it makes the Horizontal or In/Out moves. After it has moved to the Horizontal and In/Out positions the Vertical will move to the Centering Height. After this, all motion stops.

Bore Buttons

Pressing this button once will cause it to turn yellow. This indicates when the “Bore Left” button is pressed this cylinder will not be bored.

Touching this button again (with a pause in between touches) will turn the button back to green. All green bores will be bored if the “Bore Left” button is pressed. The control will ask you if you sure you want to bore the selected bores.

Double Clicking a Bore button will keep it green and turn all other bore buttons yellow.

Indicated

This screen is designed to manually indicate each cylinder in for it’s specific location.

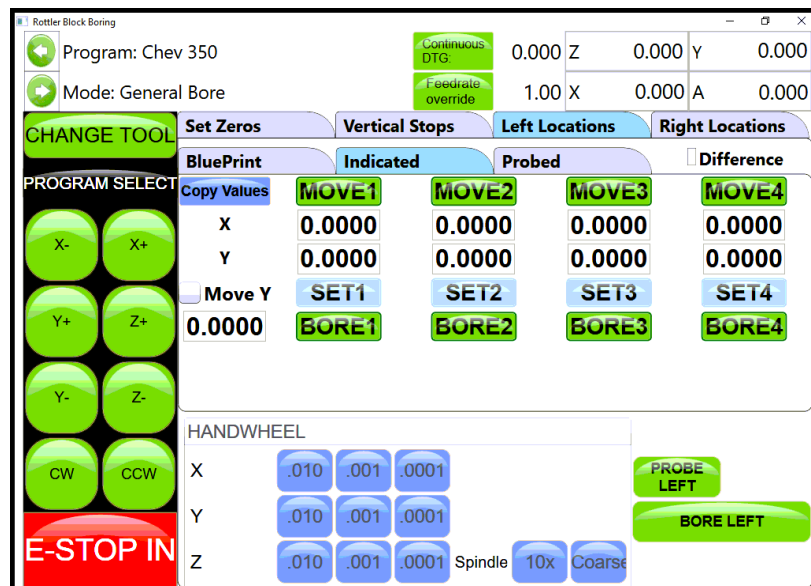

Set Buttons

Once a cylinder has been indicate, pressing the associated Set Button will take the current machine position and place the values in the Data Box associated with that cylinder.

Copy Values

Pressing this button will bring up another window where you can select to copy the In/Out and Horizontal values from Blueprint, Indicated or Probed screen.

Difference

Checking this Box will cause a green check mark to be placed in the box. The Data Boxes will then display the difference in values from the blueprint screen to the indicated screen. This is helpful to know how far the cylinders actual location is from blueprint values.

Bore Left and Right

Pressing this button will cause the entire Left or Right bank to be bored automatically. The Bore buttons that are yellow will not be bored though.

Probing

This screen is designed to automatically probe one or all of the cylinders.

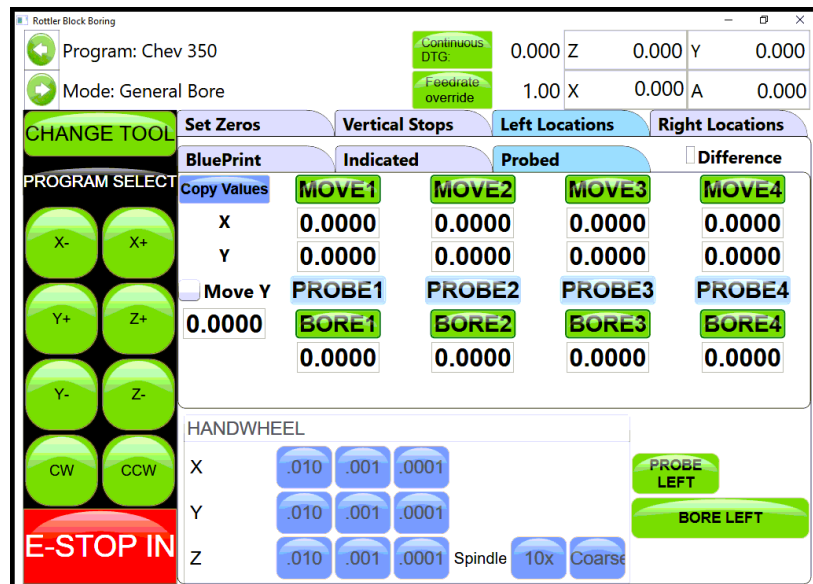

Probe Buttons

Pressing this button will cause a probing routine to be run on the associated cylinder.

Probe Left or Right

Pressing this button will cause the entire Left or Right banks to be probed automatically.

Probed Diameter

This Data Box will display the diameter of the cylinders as they are probed.

Probing For The Mill Cycle

The Rottler Milling program is set up to Automatically Probe the Deck height of a block and then Mill it to a set Deck Height. This can be done on a 3 or 4 axis machine. This will also cover Setting Tool Offsets.

Table of Tools for Milling

You **MUST** use the Table of Tools if you want to Automatically Probe the deck height and cut it to a set height. Once done the Table of Tools Should look similar to the below picture. The 100mm Probe is Tool 1. The 10" Fly Cutter is Tool 2.

Go to Program Select, and then select the block you are working with.

Install the Probe physically into the spindle. If you have a 4th axis rotate it to Zero degrees. Indicate the Middle flat on the head stock to be sure it is zero all the way across. There should be a number stamped into the headstock.

This is the distance from the Flat to the center of the Crank. Bring the probe down until it just touches the middle flat.

Open the Table of Tools and double click on Tool1 100 mm Probe. Enter the Measured diameter of your probe. This is not used in the Milling Program but *needs* to be entered accurately for Probing in the Bore mode.

On the open window select Get Length. This will open another Window. There will be a value, that you cannot edit, in the "Z Location from Zero" this is the distance the Vertical Axis is from home when the Probe touches the Middle flat.

In the Data box for "Z Touch off Height" enter the number that is stamped on the Head Stock. This is the distance from the flat to the center line of the Crank.

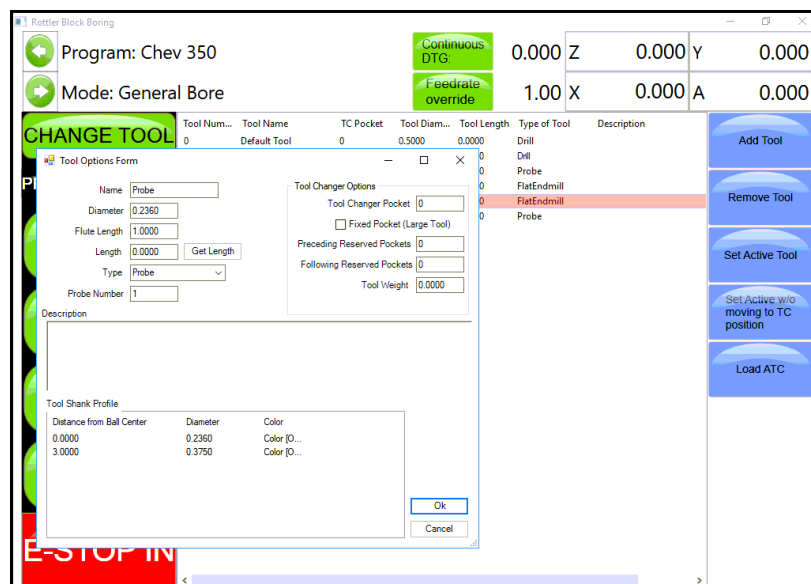

Select "OK" on both windows. This will put the Total tool length into the Table of Tools. The Vertical Digital Read Out will now consider the center of the Crank bore to be the Vertical Zero position. When the Probe tip or Cutting insert touches the Deck the Vertical DRO will be reading out the distance from the center of the Crank bore (Actual Deck Height).

Assigning Tools

From the Set Zero Tab, select Probe#. This will open the Tools Select Form. Select Tool 1, 50 mm Probe and click "OK".

Select the Tool#. This will open The Tool Select Form. Select Tool 2, 10-inch Fly Cutter and click "OK".

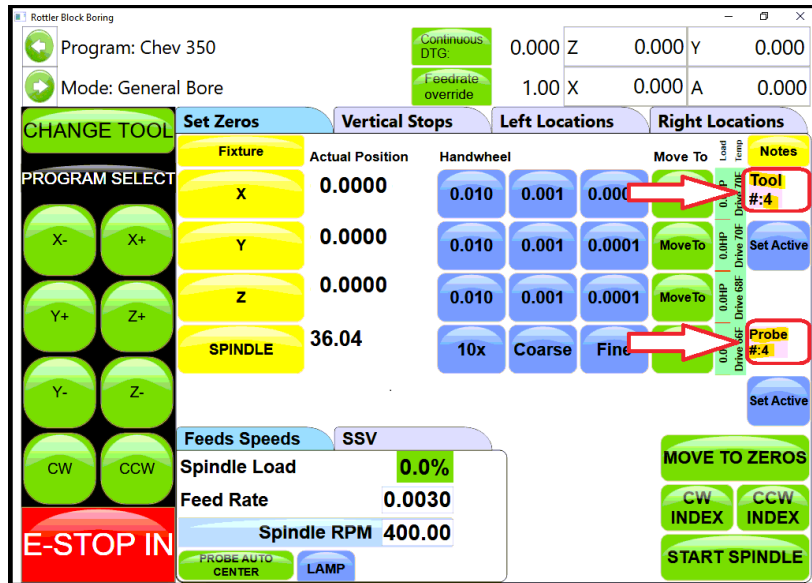

The tools to be used have now been assigned to the program.

Left Deck Probe

Enter the positions you want the Probe to probe here. You can physically move the probe to the locations on the bank you want to probe and hit the set button also.

Right Deck Probe

Roll the block over to the Right Bank. Enter the positions you want the Probe to probe here. You can Physically move the probe to the locations on the bank you want to probe and hit the set button also.

Auto Probing

Press the Start Probing button. The machine will first probe each programmed location on the left bank and record the height. The spindle will move to Vertical Clearance height and the block will roll over to the right bank and probe the programmed locations and record them. If you have a 4th axis The block will then roll back over to the Left bank and the spindle will move to the first Left location and stop.

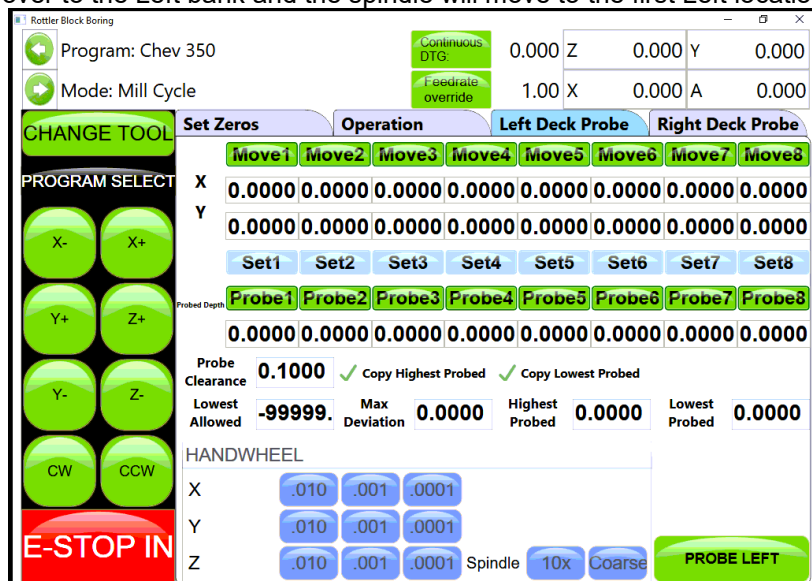

Lifter Bore

The Lifter Bore Mode and its buttons operate identical to the Bore Mode with a couple of exceptions.

On the Program Vertical Stops screen, lower Clearance Offset is not an option.

After a bore is complete the spindle will not offset .020" for tool clearance unless the "Horizontal Offset after Cycle" box is checked. This is used when a single point boring tool is used for lifter boring.

Cylinder Bore 4 Axis

Most of the Control Definition in the 4th axis is the same as the 3 axis version of software. Only the differences or new features will be discussed in this section.

Set Zero Tab

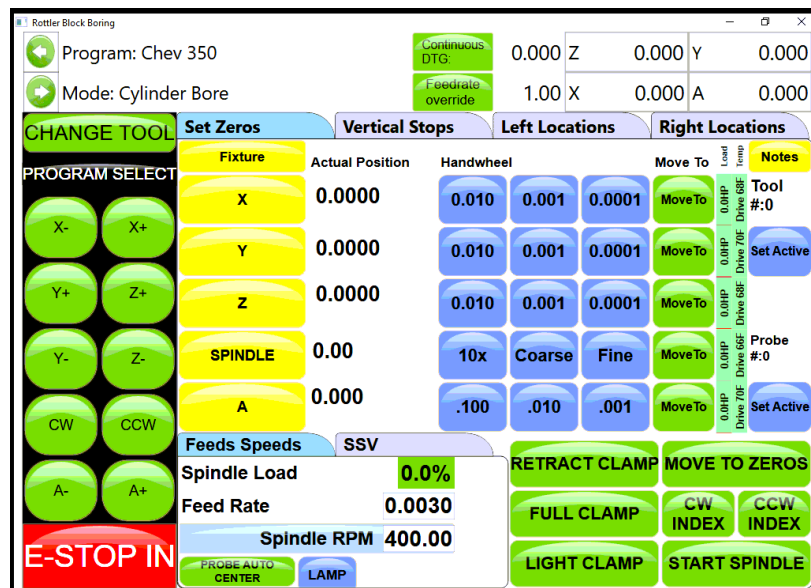

Jog Controls

4Th-

Pressing this button will cause the 4th axis to rotate in a negative direction while held.

4Th+

Pressing this button will cause the 4th axis to rotate in a positive direction while held.

4th Axis Degree and Move

Touching the 4th Axis Degree Data Box will bring up a Pop-Up Menu so a degree can be entered. Once a value is entered (even zero), pressing the Move button will move the 4th axis to that position.

4th axis Brake

This shows the status of the 4th axis brake as well as manually turning the brake on and off. When the 4th axis is rotated using the jog controls the fixture will automatically switch the brake On and Off.

Light Clamp

Pressing this button will cause light pressure to be exerted from the Tail Stock towards the Head stock. When the 4th axis is rotated using the jog controls the fixture will automatically switch from Full to Light clamp and back.

Full Clamp

Pressing this button will cause full pressure to be exerted from the Tail Stock towards the Head stock.

Retract

Pressing this button will cause the tail stock to fully retract. A dialog box will appear when this button is pressed to assure you want to retract the tail stock. This is to prevent an accidental retraction when a block is in the fixture.

Table Of Tools

The Table Of Tools is a very powerful feature in this software. Most of the Rottler programs are designed to be used without interacting with the Table Of Tools.

Only the program specific uses will be described here.

Table Of Tools General Information

The Table Of Tools is used to set different tool lengths so multiple tools can be used in one program and reference the same vertical zero position.

For Example, if you were to use two boring bars in one program. One boring bar is 8" long and the other is 4" long. There is then a 4" difference in where the cutter of each bar will come into contact with the part to be machined. Using the Table of Tools, you can set the 4" difference for one of the boring bars so that both of the cutting tools will come into contact with the material at the same vertical position.

Accessing Table Of Tools

Select TABLE OF TOOLS from any screen in the upper left-hand corner. This will open up the Table Of Tools.

On this screen you will be able to Add, Remove or Set that tool Active (installed in spindle and being used).

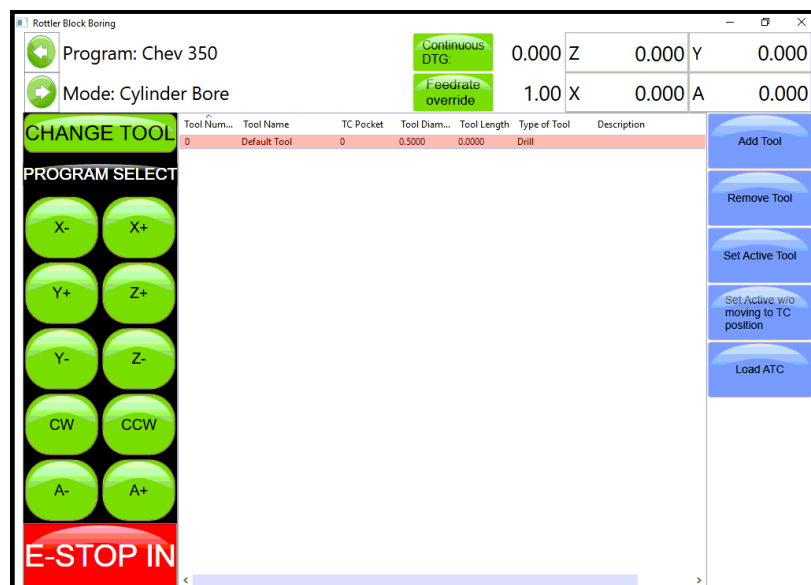

The Table of Tools comes with Tool 0 installed with no offset amount. Tool 0 will remain tool 0 with no offset always. Tool 0 will be set active when you are using programs that do not require tool offsets.

Add Tool

To add a tool to the Table of Tools press Add Tool. This will open another window. Here you will name the Tool you are adding. Such as 2.9 production Stub. It is important to give an accurate name to the tool. You want the tool easily identifiable by its name. The only other data box the Rottler software uses is the Length Data Box. This will be discussed later. Press OK.

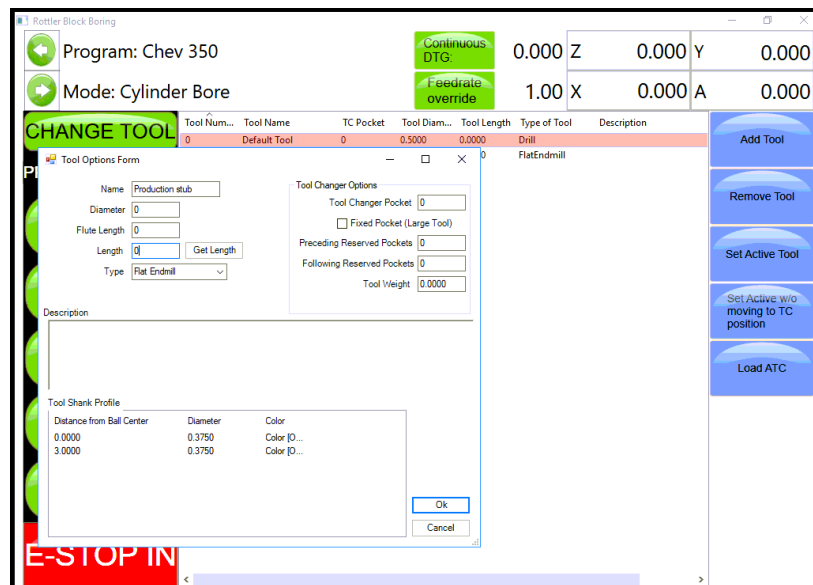

The Added tool will now show in the Table of Tools.

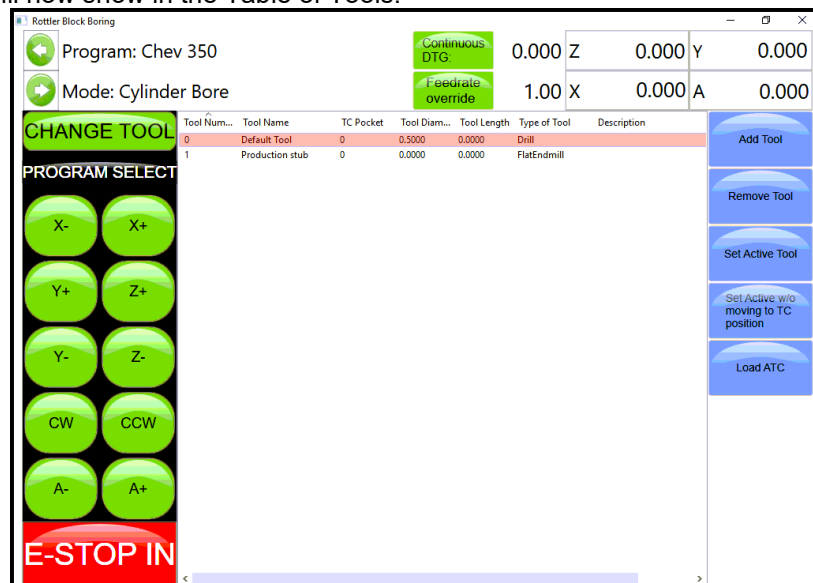

Remove Tool

Pressing this button will remove the highlighted tool from the Table of Tools.

Set Active Tool

Pressing this button will set the highlighted tool to an Active Status (tool installed and will be used) Any Vertical offset associated with that tool will be used when a program is run. You can tell which tool is active because it is highlighted in Red. When no offset is required in a program Tool 0, Default Tool should be active.

When setting a tool active another window will open. This is the Tool Change Form. It is basically there to verify the tool information before it is set to an active status. Verify the information and press OK.

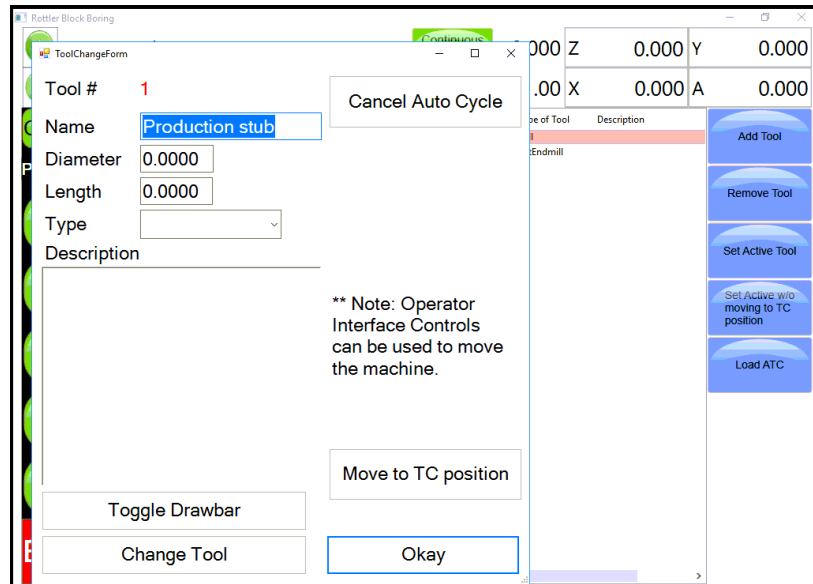

This window will open when the machine does an automatic tool change. This will be discussed in Chapter 5 Operating Instructions. After you press OK another window will open. This is a Warning Dialog box to inform the operator of the possibility of the spindle start if the tool change is done in an automatic program. Press OK.



Setting Tool Offsets

Add all the tools that will need offsets into the table of tools. Leave the Length value at 00.00 when you first enter them.

For this example, we will be setting offsets for a 2.9 Production Stub, 100mm Probe and a 10 inch Fly cutter. Add these tools to the table of Tools.

NOTE: Only the Probe will use the Tool Diameter. The Probe will use the Tool Diameter when probing a cylinder, it will not use the Tool Diameter when touching off a surface such as a block deck. Changing this setting will be discussed later in this Chapter.

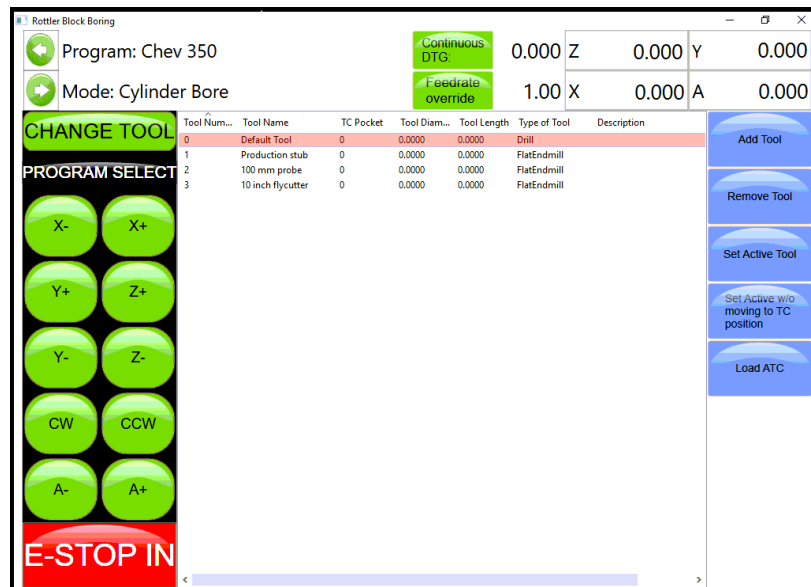

To set Tool Offsets you will need a fixed vertical reference point on the machine that does not change such as the head stock of the 4th axis or Performance Fixture.

Install the first tool such as the 2.9 Production Stub with Cutting insert installed. Bring the cutting insert down until it just touches the flat on the head stock of the 4th axis fixture. Go to the TABLE OF TOOLS and double click the 2.9 Production Stub tool. Select Get Length from that window. This will bring up the Tool Length window.

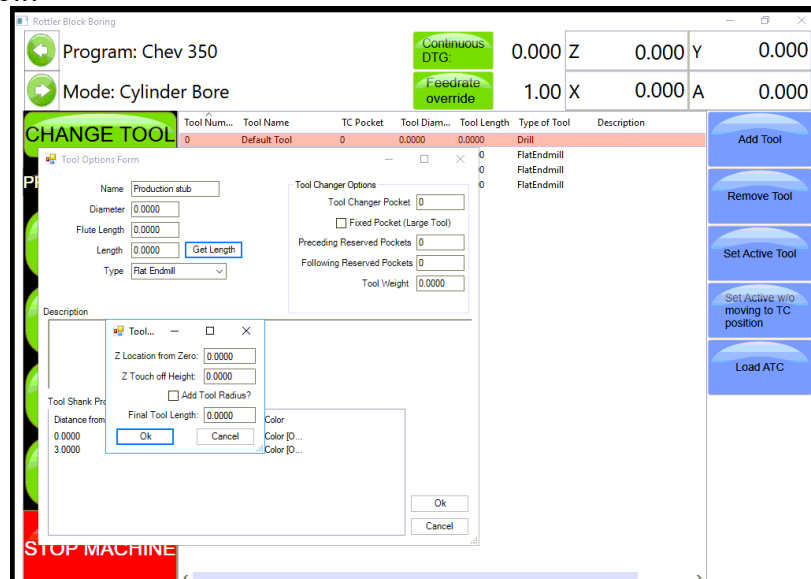

Z Location from Zero

This is the distance the Vertical Axis is from the home position. NOT where the operator has set the Vertical Zero in the program. This value is set by the computer automatically. In this example the tool just touched the flat at 8.0000.

Z Touch Off Height

This value is an additional value you want added to the Z location from zero. For example, if you wanted to use the center of the Crankshaft as the vertical reference point, but you are touching the tool off of the flat of that head stock, you would enter the distance from where you are touching off to the center of the Crank (this value is stamped into the headstock by Rottler). The values from Z Location from Zero and Z Touch off Height are added together by the computer to get the Final tool Length value. If you are not referencing another vertical position, then this value will remain 00.000.

Add Tool Radius?

Checking this box will add the Tool Radius to the Final Tool Length. This is not used in the Rottler programs and should remain unchecked for all tools.

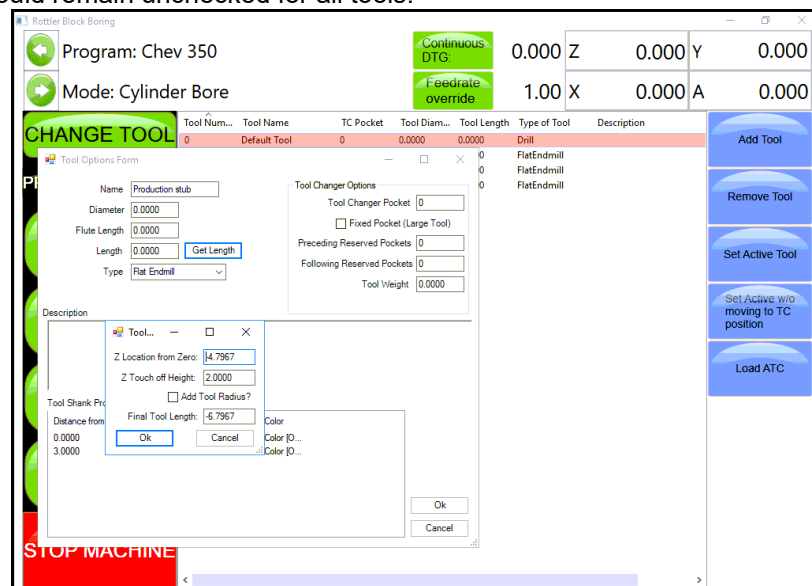

Repeat this procedure for each tool. Touch ALL of them off from the same point. When running a Rottler program the cutting insert for each tool will reference the Vertical Zero the operator set in the program and come into contact with the surface to be machined at the same vertical value.

Applying Table of Tools to Rottler Programs

The use of the Table of Tools to specific Rottler programs such as Bore and Mill will be defined in Chapter 5 Operating Instructions.

Fixture Select

This is also a very powerful tool. It is not generally used in the Rottler Programs. It's basic function is to offset a program and table of tools a set distance on each axis (if desired) and run the program without resetting axis zero points.

For example, if you have two fixtures that are identical but are set at a different location on the table you can set the difference values in the table of fixtures and run the program. It is recommended this is not used unless you are a very experienced operator.

Tool Changer On An EM45

This will cover setting EM tool changer operation. Using the ATC, the machine will be making automatic moves, be aware of pinch points. This requires knowledge of machine setup, program setup and access to the software setup. Incorrect setup of an ATC can cause damage to tools or to the tool holder pockets and sheet metal of the ATC.

1. It is important to give an accurate name to the tool. You want the tool easily identifiable by its name.
2. There is a box that you can check on labeled Fixed Pocket (Large Tool). This is for cutters that have a greater diameter than 3.0”(75mm). As an example, a typical flycutters used for surfacing decks is 10.0”(255mm) diameter. In this case you would want to select the Fixed Pocket box and leave the two pockets before and after the large diameter.

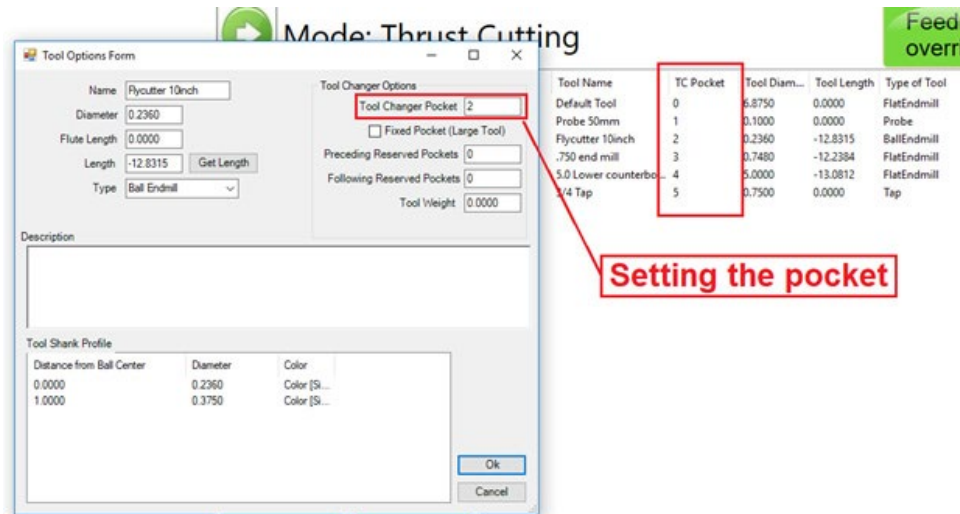

Pressing the Set Active button will set the highlighted tool to an Active Status which triggers the tool changer to perform a tool change to that specific tool.

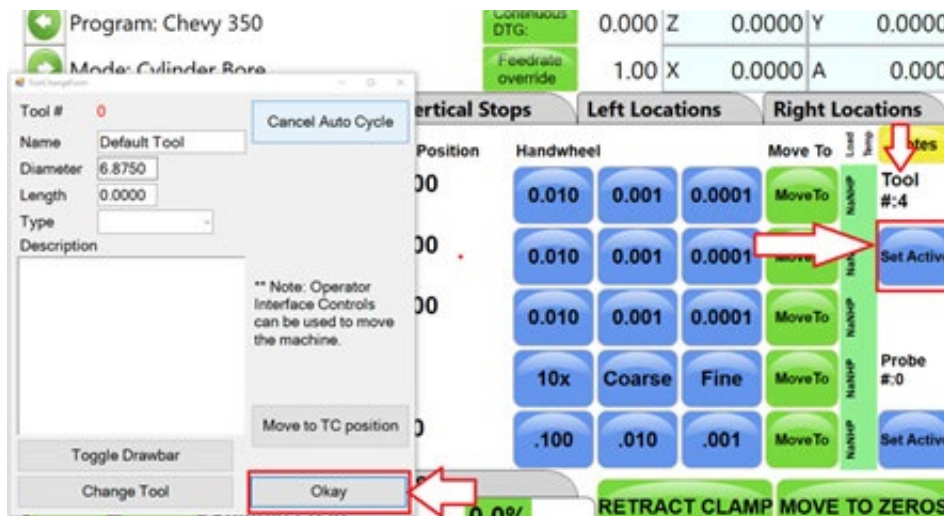

OPERATING INSTRUCTIONS

Contents

Operating Instructions	4-7
Loading Blocks	4-7
Small Gas and Diesel Blocks	4-7
Manual V6/V8 Combination Fixture 502-1-72H	4-7
Boring Application.....	4-7
V-Blocks	4-7
Y-Blocks	4-7
Normal Operating Procedure.....	4-9
Surfacing Application	4-10
V-Blocks	4-10
Y-Blocks	4-10
Normal Operating Procedure.....	4-12
Retrofitting 502-1-15C Parallels to V6/V8 Combination Fixture.....	4-13
Diesel Blocks	4-15
6725 Diesel Fixture	4-15
Small Diesel V-Blocks	4-15
Triangle Clamping, V-Blocks.....	4-16
Block Clamp Arm	4-16
Small Diesel In-Line Blocks	4-18
Triangle Clamping, In-Line Blocks.....	4-19
7119V Dual Axis Table Assembly	4-21
Instructions for Small In-Line Blocks	4-22
Mounting Block to Table	4-22
Blocks with Main Caps Removed or Raised Main Bearings	4-22
Blocks with Main Caps Installed.....	4-23
Typical Head Set-up Procedure	4-24
Setting Up Rottler Flycutters With Two Inserts	4-26
General Machine Information	4-27
Homing	4-28
Building Programs	4-28
Create a Block Program	4-28

Options	4-28
Std (Standard) Setup	4-28
Select	4-28
Probing For Automatic Cycle	4-29
Setup of tools for Probing to Bore	4-29
Cylinder Bore Mode, 3-Axis	4-31
Setting Zeros	4-31
X- and Y-Axis Zeros	4-32
Z-Axis Zero	4-32
Blueprinting Method.....	4-32
Programming Vertical Stops	4-33
Block Clearance.....	4-33
Centering Height.....	4-33
Start Boring Height	4-34
Bottom of the Bore.....	4-34
X Offset for Honing	4-35
Start Offset Height	4-35
Horizontal Offset	4-35
Change Speeds at Horizontal Offset.....	4-35
Washout Cycle.....	4-36
Stop and Index Spindle after Cycle.....	4-36
Bore Locations.....	4-36
Left Locations	4-37
Right Locations	4-37
Boring a Block.....	4-37
Indicator Method.....	4-38
Block Clearance.....	4-38
Centering Height.....	4-38
Start Boring Height	4-39
Bottom of the Bore.....	4-39
Bore Locations.....	4-40
Boring a Block.....	4-41
Probing Method	4-42
Vertical Zero	4-42
Programming Vertical Stops	4-42
Block Clearance.....	4-42
Centering Height.....	4-42

Start Boring Height	4-42
Bottom of the Bore	4-42
Probe Height.....	4-43
Bore Locations.....	4-43
Probe Auto Center	4-43
Automatic Probing Procedure	4-44
Boring a Block.....	4-44
Cylinder Bore Mode, 4th Axis	4-45
Setting Zeros	4-45
4 th Axis (Rotational) Zero	4-45
Finding the Y-Axis Zero with 4 th Axis.....	4-45
Building Programs with 4 th Axis.....	4-45
Setting Vertical Clearance with 4 th Axis.....	4-45
Table of Tools for 3 and 4 Axis Bore Mode	4-45
Building a Program with Table of Tools.....	4-45
Assigning Tools	4-46
Mill Mode, 3-Axis.....	4-47
Mill Cycle.....	4-47
Setting Zeros	4-47
X-Axis (Horizontal) Zero.....	4-47
Y-Axis (In/Out) Zero.....	4-47
Z-Axis (Vertical) Zero	4-47
Feeds and Speeds (IPR/RPM).....	4-47
Manual Procedure for Setting Z- and X-Axis Zeros	4-48
Operation	4-48
Horizontal End	4-48
Amount Per Pass.....	4-48
Vertical Start	4-48
Vertical End	4-48
Copy Lowset/Highset.....	4-48
Rough Settings	4-48
Rough Feed Rate	4-48
Rough Spindle RPM	4-48
Finish Cut Settings.....	4-49
Finish Amount.....	4-49
Finish Feed Rate	4-49
Finish RPM	4-49

A-Axis	4-49
Overlap Mill Settings	4-49
Start Auto Cycle	4-49
Mill Mode, 4-Axis	4-50
Program Additions to 3-Axis Operation	4-50
4th Axis Angles	4-50
Left Bank Angle	4-50
Right Bank Angle	4-50
Rollover Vertical Clearance	4-50
Cut Left and Cut Right	4-50
Start Auto Cycle	4-50
Milling Using Automatic Deck Probing	4-51
Table of Tools for Milling	4-51
Building a Program Using the Probe and Table of Tools	4-52
Probe Auto Center	4-52
Probe Depth	4-52
Probe Inside Diameter	4-52
Probe Outside Diameter	4-52
Probing Engine Block Surfaces	4-52
Left Deck Probe	4-53
Right Deck Probe	4-53
Probe Clearance	4-53
Lowest Allowed	4-53
Auto Probing	4-53
Auto Milling	4-54
Vertical Start	4-54
Vertical End	4-54
Start Auto Cycle	4-54
Lifter Bore Mode, 3-Axis	4-55
Y-Axis Zero	4-55
Start Boring Height	4-55
Lifter Bore Angle	4-55
Lifter Bore Mode, 4-Axis	4-56
Start Boring Height	4-56
Lifter Bore Angle	4-56
Calculate Y-Axis Zero	4-56
Line Bore Mode	4-57

Mounting and Aligning Right Angle Drives	4-57
Setting Zeros	4-58
X-Axis Zero	4-58
Y-Axis Zero	4-58
Programming Vertical Stops	4-59
Bore Centerline	4-59
Block Clearance.....	4-59
Programming Horizontal Stops	4-59
Programming Bore Length	4-59
Running the Auto Cycle	4-59
Thrust Cutting.....	4-60
Setting Zeros	4-60
X-Axis Zero	4-60
Y-Axis Zero	4-61
Dimensions & Auto Cycle.....	4-62
Thrust Dimensions.....	4-62
Outside.....	4-62
Inside	4-62
Cutter	4-62
Clearances	4-62
Z-Axis (Vertical)	4-62
X-Axis (Horizontal).....	4-62
Bore Dimensions	4-62
Main Width	4-62
Insert Width.....	4-62
Left Depth of Cut	4-62
Right Depth of Cut.....	4-62
Cut Left Side.....	4-62
Cut Right Side	4-62
Cut Both Sides	4-62
Description and Running of the Auto Cycle.....	4-63
Start Auto Cycle	4-63
Cam End Tunnel Boring.....	4-63
Cam Tunnel Boring.....	4-64
Zeroing the Micrometer.....	4-65
Setting the Cutting Size.....	4-65
Setting Vertical Stops	4-66

Setting Horizontal Stops	4-66
Auto Cycle	4-66
Manual Bore	4-67
Recommended Boring Procedure.....	4-67
Connecting Rod Boring	4-67
Main Screen	4-67
Setting Zeros	4-67
Setting Vertical Zero	4-68
Program Options	4-68
Auto Cycle	4-69
Fixture Control Panel.....	4-70
Setup Procedure for Conrod Fixture.....	4-70
Air Pressure Settings	4-71
Backing Up and Restoring Block Profiles	4-72

Operating Instructions

The purpose of this chapter is to explain and guide the operator from loading a block through running an automatic cycle.

All modes of operation will be discussed in this chapter.

Note: *We recommend, particularly for operators unfamiliar with this machine, to practice on a junk block in order to become familiar with the controls and procedures of the machine.*

Loading Blocks

Small Gas and Diesel Blocks

Manual V6/V8 Combination Fixture 502-1-72H

 **WARNING** Handle the block and fixture with EXTREME care and guidance. A block hoist is REQUIRED. Mishandling of a heavy engine block and fixture may result in the dropping of parts and personal injury.

The Model 502-1-72H manual V6/V8 combination fixture is a fast, simple and universal system to properly and accurately hold most 60-degree V-type engine blocks for either cylinder boring or deck surfacing.

See illustration on the following page.

Boring Application

NOTE: *The block must have the main bearing caps in place and torqued.*

Care must be taken to assure the contact edges of the locator bar are near the cap split line. A pair of 3/8" and 1/2" spacers are provided for blocks with large main bearing bores, to enable the bar to locate near the main bearing split line. (See figure 2)

V-blocks: (blocks with main bearing center lines no more than 1/2" higher than the pan rail plane) are mounted with the 502-3-8B V-block frame in place. Select the 90-degree option placement of the frame to suit block length, or main bearing caps will interfere with frame. Rotate frame 90 degrees by moving its shoulder screws to alternate set of holes.

Y-Blocks: (blocks with main bearing center lines 2-3/8" to 3-1/2" higher than the pan rail plane) are mounted directly on the fixture. Some Y-blocks (GM 60 degree) have too narrow pan rails and some have too low main bearing location which will require the use of the 502-1-15C precision 1-1/4" x 3" parallel set to raise and or support the block. Use the shoulder screw from the V-block frame and hook the parallels over the back of the V-fixture.

This fixture may be easily repositioned on the support parallels (without a block in place) to shift from the 60-degree support surface to the 90-degree support surface or vice versa.

WARNING Extreme care must be taken by the operator whenever handling large blocks. Large blocks may cause fixture to tip when floated too far outward. We recommend leaving the hoist attached when moving these blocks. Large blocks should be lifted from the block bank surface.

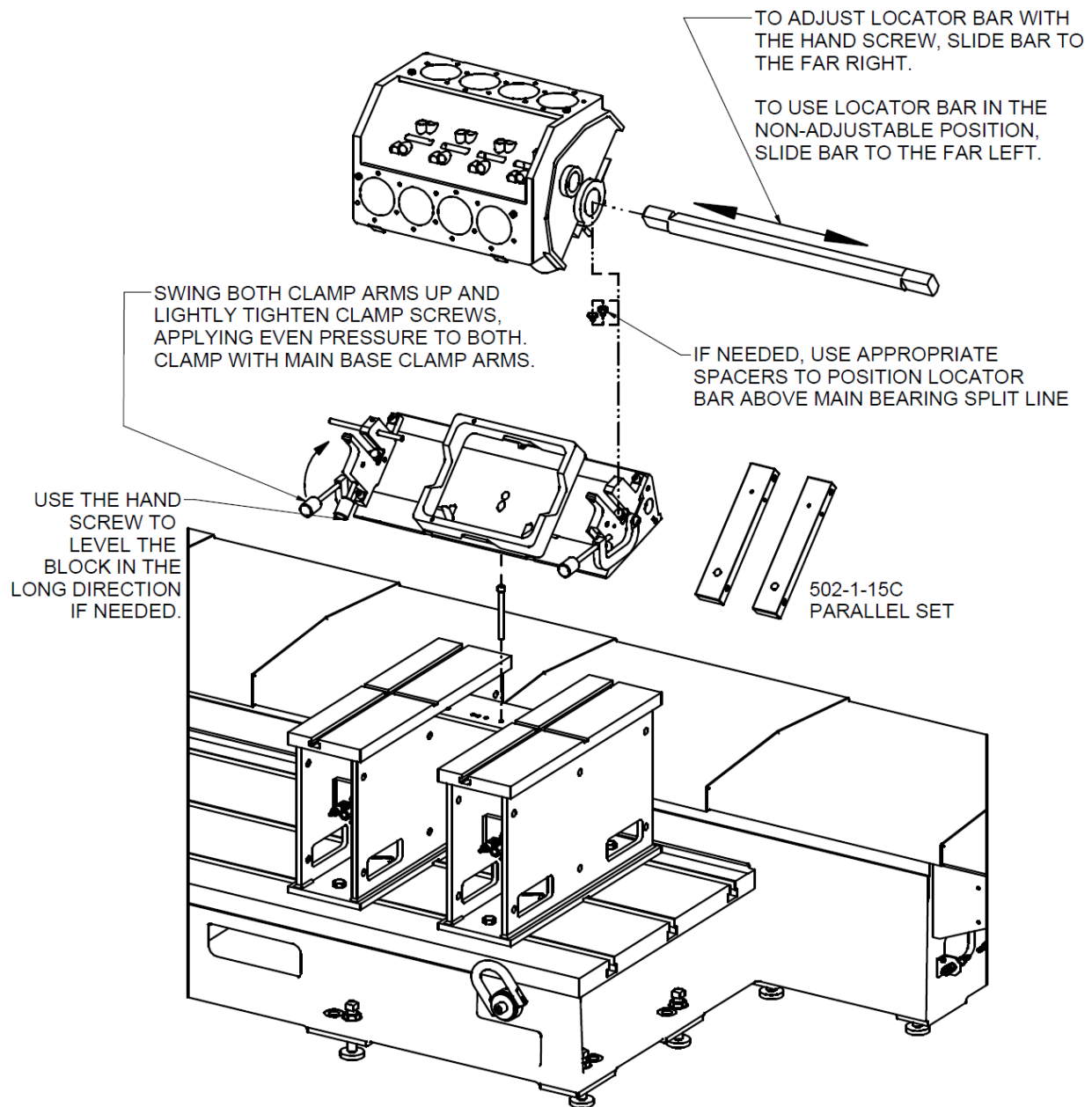

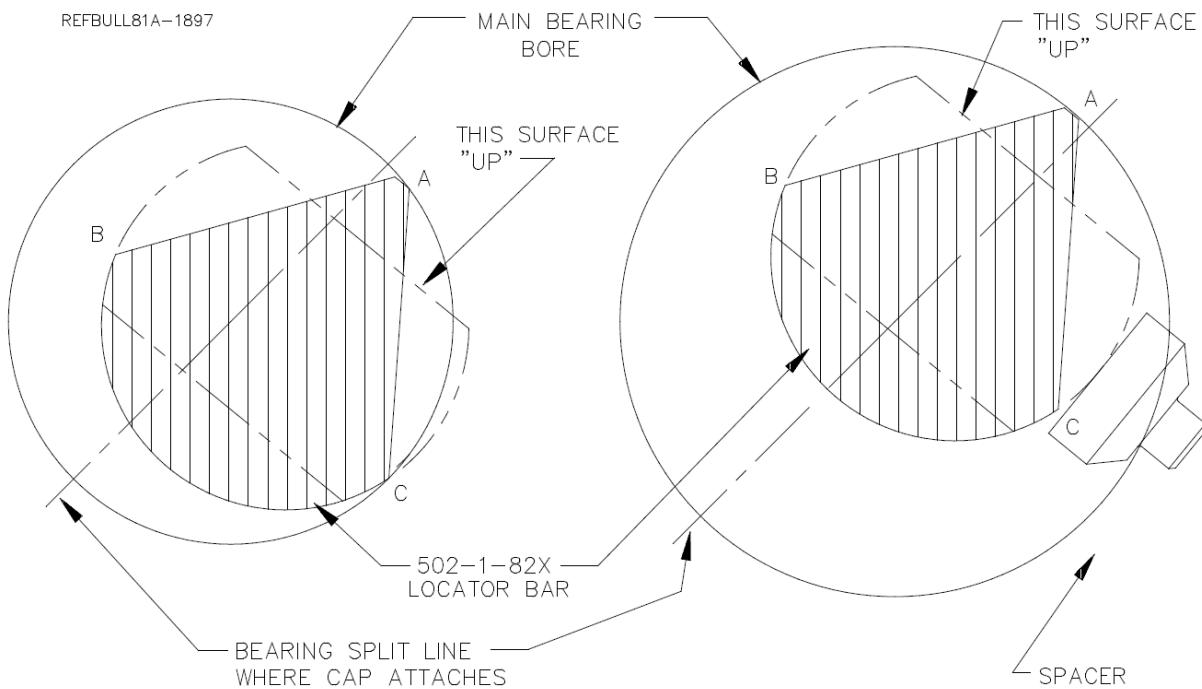

FIGURE 1

FIGURE 2

Normal Operating Procedure

Place the 502-1-82X locator bar through the main bearings and hoist the block into the fixture. Pulling the block towards you, with the locator against the positioners, will prevent jamming in the slot of the guides during the loading and unloading operations. The locator bar is positioned with the word 'UP' that is on the end of the bar facing up and away from the operator. (see figure 1) After the locator bar is engaged in the positioners, pivot the block outwards as you lower it. Slide the block to the far left (this is the nonadjustable position).

Make sure the block is firmly seated in place and not resting on the pan-rail, burrs or other interference points. Accurate seating can also be a problem with extremely warped or distorted blocks. Another cause of problems is failure to remove main bearing inserts. The locator bar has a relief for blocks with a small main bearing or seal. Rotate locator bar clamps into position & lightly tighten the hand screws, applying even pressure to both. Clamp the block securely with the main base clamp arms.

Warped or distorted blocks may require leveling of the deck surface in the long direction. This is possible with the hand-screw assembly in the left-hand bar positioner. Loosen both clamp hand-screws and slide the locator bar to the far-right position. Retighten both clamp hand-screws. Raise or lower the adjusting hand-screw as required. For the non-adjustable position slide locator bar to the far left.

Push the fixture back into bore position. There is a guide block (502-1-105) attached to the bottom of the fixture to aid in guiding the fixture along the support ways.

Operate the block clamp arms, bore, and pull fixture back to the load position.

Loosen locator bar hand screws and rotate clamps out of the way. Lift the block, either from the deck surface or with the optional 502-1-95 block handler. Turn the block 180 degrees & reload to duplicate the operation on the other bank.

After turning the engine block 180 degrees the locator bar must be twisted 180 degrees also. Again the word 'UP' must enter the positioners facing up and away from the operator. (See figure 1).

Figure 1

502-1-82X main bearing locator bar indexes at point A. When bank is reversed and the bar is twisted 180 degrees, point A still indexes the main bearing.

Point C holds the block down. When bank is reversed and the bar is twisted 180 degrees, point B holds the block down.

Figure 2

502-1-82X main bearing locator bar indexes near bearing split line. Point C does not contact the bearing cap but rests on matched spacers that are provided to fit in the bar positioners slot. If there is a means of holding the block down such as block clamp towers, this method may be used in large bores in order to properly index near the bearing split line. If extreme care is used this method may be used to index blocks without bearing caps attached. (Optional clamp down must be provided).

Surfacing Application

NOTE: The block must have the main bearing caps in place and torqued.

Care must be taken to assure the contact edges of the locator bar are near the cap split line. A pair of 3/8" and 1/2" spacers are provided for blocks with large main bearing bores, to enable the bar to locate near the main bearing split line. (See figure 2)

V-blocks:

(blocks with main bearing center lines no more than 1/2" higher than the pan rail plane) are mounted with the 502-3-8B V-block frame in place. Select the 90-degree option placement of the frame to suit block length, or main bearing caps will interfere with frame. Rotate frame 90 degrees by moving its shoulder screws to alternate set of holes.

Y-Blocks:

(blocks with main bearing center lines 2-3/8" to 3-1/2" higher than the pan rail plane) are mounted directly on the fixture. Some Y-blocks (GM 60 degree) have too narrow pan rails and some have too low main bearing location which will require the use of the 502-1-15C precision 1-1/4" x 3" parallel set to raise and or support the block. Use the shoulder screw from the V-block frame and hook the parallels over the back of the V-fixture.

This fixture may be easily repositioned on the support parallels (without a block in place) to shift from the 60-degree support surface to the 90 degree support surface or vice versa.

WARNING Extreme care must be taken by operator whenever handling large blocks. Large blocks may cause fixture to tip when floated too far outward. We recommend leaving hoist attached when moving these blocks. Large blocks should be lifted from the block bank surface.

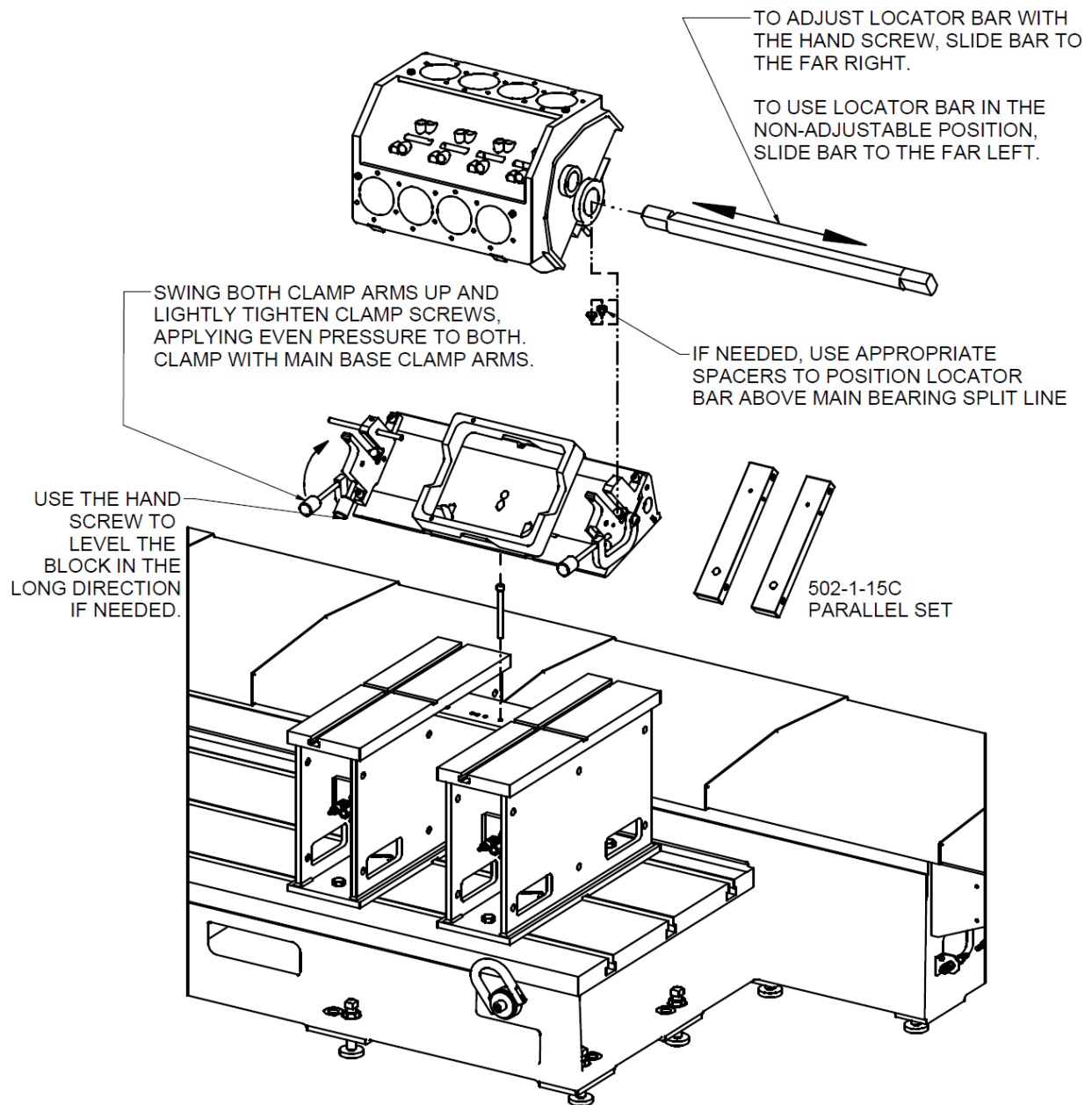

Normal Operating Procedure

Place the 502-1-82X locator bar through the main bearings and hoist the block into the fixture. Pulling the block towards you, with the locator against the positioners, will prevent jamming in the slot of the guides during the loading and unloading operations. The locator bar is positioned with the word 'UP' that is on the end of the bar facing up and away from the operator. (see figure 1) After the locator bar is engaged in the positioners, pivot block outwards as you lower it. Slide block to the far left (this is the nonadjustable position).

Make sure the block is firmly seated in place and not resting on the pan-rails, burrs, or other interference points. Accurate seating can also be a problem with extremely warped or distorted blocks. Another cause of problems is failure to remove main bearing inserts. The locator bar has a relief for blocks with a small main bearing or seal. Rotate locator bar clamps into position & lightly tighten the hand screws, applying even pressure to both. Clamp the block securely with the main base clamp arms.

Warped or distorted blocks may require leveling of the deck surface in the long direction. This is possible with the hand-screw assembly in the left-hand bar positioner. Loosen both clamp hand-screws and slide the locator bar to the far-right position. Re-tighten both clamp hand-screws. Raise or lower the adjusting hand-screw as required. For the non-adjustable position, slide locator bar to the far left.

The shim stock is put in place to raise the back side of the block, you can then use the Jacking Screw to raise and lower the front of the block. There is a guide block (502-1-105) attached to the bottom of the fixture to aid in guiding the fixture along the support ways.

Operate the block clamp arms, surface, and pull fixture back to the load position.

Loosen locator bar hand screws and rotate clamps out of the way. Lift the block, either from the deck surface. Turn the block 180 degrees & reload to duplicate the operation on the other bank.

After turning the engine block 180 degrees the locator bar must be twisted 180 degrees also. Again, the word 'UP' must enter into the positioners facing up and away from the operator. (See figure 1).

Figure 1

502-1-82X main bearing locator bar indexes at point A. When the bank is reversed and the bar is twisted 180 degrees, point A still indexes the main bearing.

Point C holds the block down. When the bank is reversed and the bar is twisted 180 degrees, point B holds the block down.

Figure 2

502-1-82X main bearing locator bar indexes near the bearing split line. Point C does not contact the bearing cap but rests on matched spacers that are provided to fit in the bar positioners slot. If there is a means of holding the block down such as block clamp towers, this method may be used in large bores in order to properly index near the bearing split line. If extreme care is used this method may be used to index blocks without bearing caps attached. (Optional clamp down must be provided).

Retrofitting 502-1-15C Parallels to V6/V8 Combination Fixture (Special Applications)

Some engine blocks with large main bores (3-1/8" and larger) cause the locator bar to bottom out in the bar positioners and/or the V-shaped relief's of the 502-3-8B V-block frame before clamping the block properly. Mounting the 502-1-15C parallel set as shown below in place of the V-block frame will provide proper clearance for clamping. Older style fixtures and parallels can be modified to this configuration using illustrations below.

V-6 blocks with one-piece 'caged' main bearing caps (all caps are connected) can interfere with 502-3-8B V-block frame. The parallel arrangement shown below will allow proper support and clamping of these blocks.

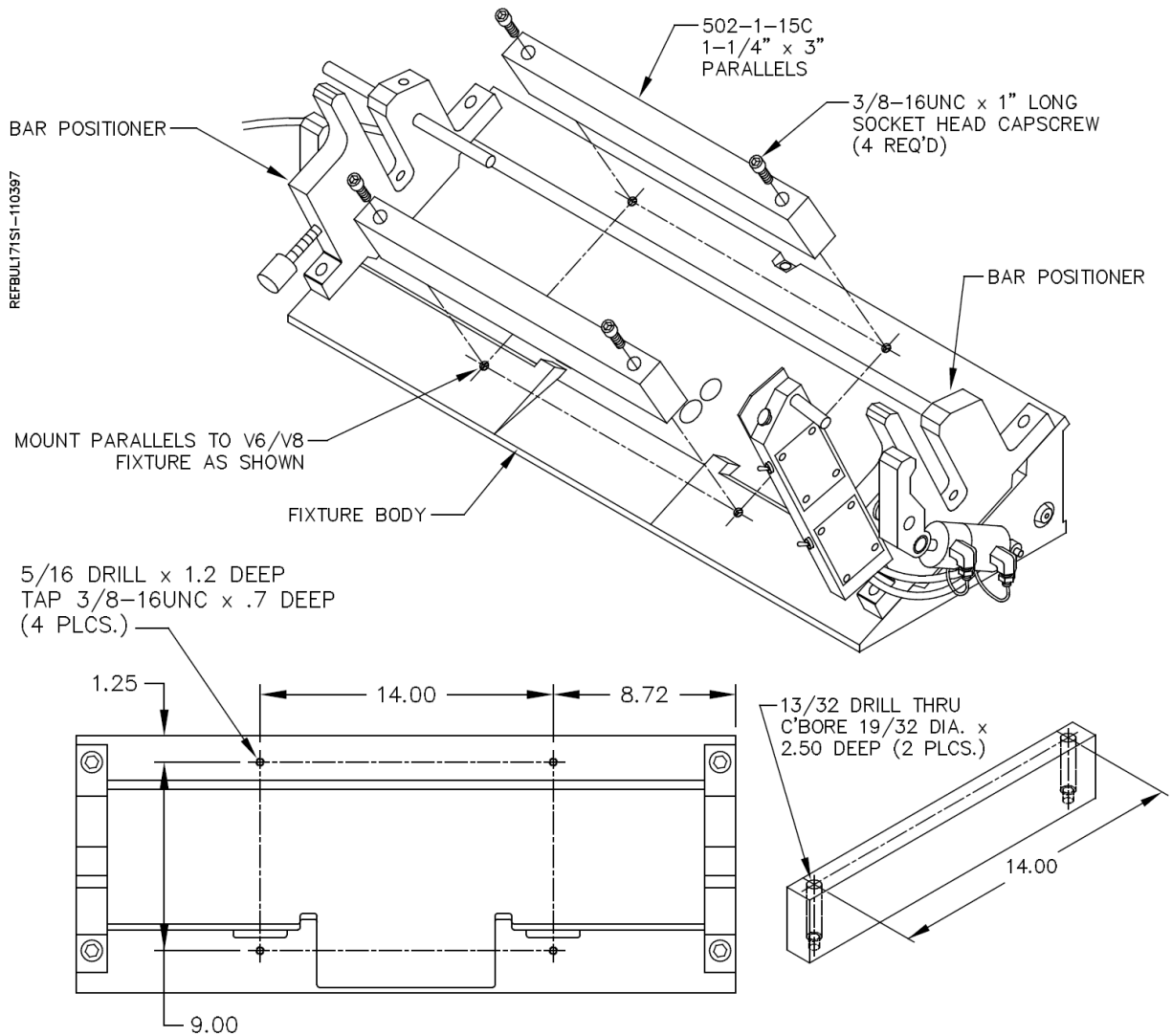

Some V-6 engine blocks (for example Buick V-6) have main bearing bores that are too low in respect to the pan rails. This causes the locator bar to bottom out in the bar positioners before the block is properly clamped. Positioning the 502-1-15C parallel set as shown below will raise the block enough to provide proper clamping.

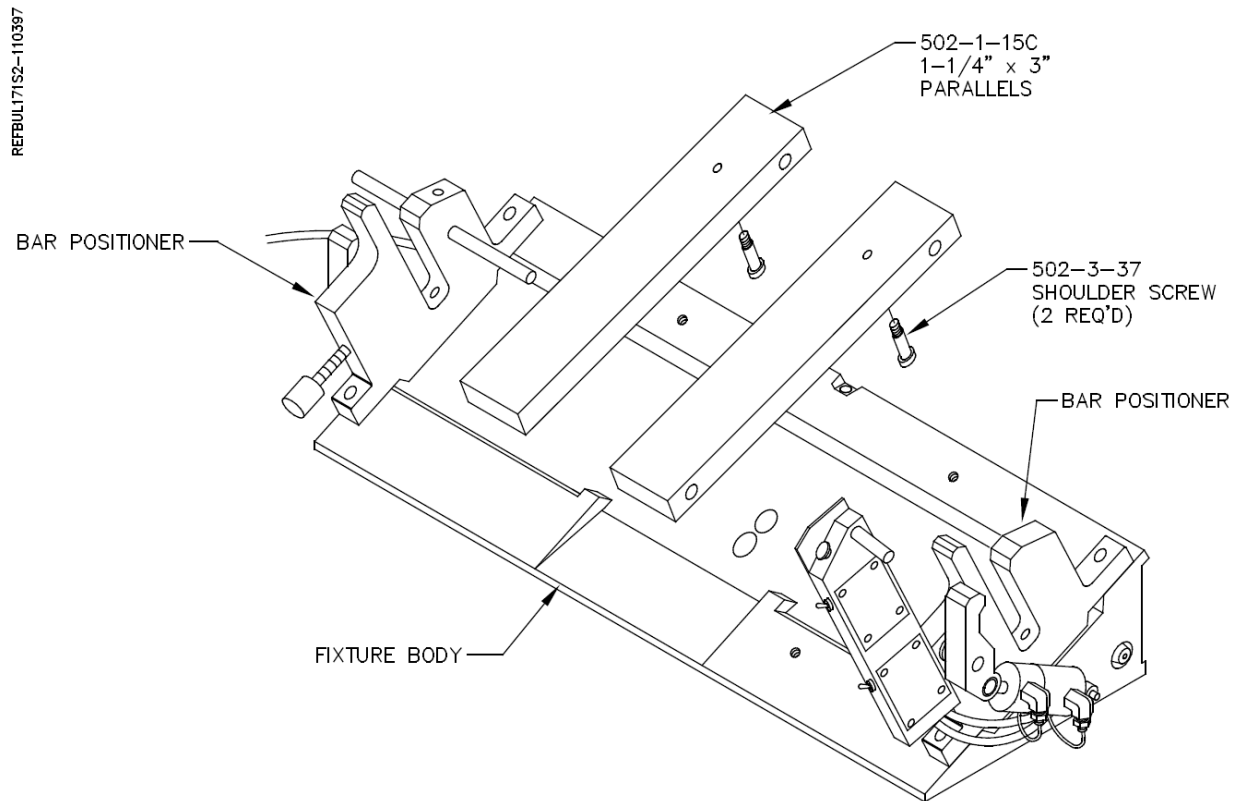

Diesel Blocks

6725 Diesel Fixture

Small Diesel V Blocks

On these blocks it will be necessary to install the 6370Z, 10" parallels or 6404E, 8" parallels onto the bed of the machine. These parallels are keyed, place them onto the deck surface and then push them toward the rear of the machine. This will locate them evenly on the middle keyway of the machine bed. Place the two 6553F main bearing supports onto the parallels, these are also keyed and fit into the machined slots on the parallels. This will put the two main bearing supports in line with each other. Tighten all bolts to lock the parallels and main bearing support into place. Select the correct size main bearing locators and install them into the mains of the block.

Note: Make sure there are no burrs or debris in the main bearing bores where they will contact the main bearing locators. This can cause the block not to clamp properly and may cause tipping or rocking of the block.



WARNING

Handle these large blocks with extreme care and guidance. A block hoist is required when handling these blocks. These blocks should be lifted from the block bank surface.

Install the main bearing locators into the mains of the engine block. Lower the block so that the locators go into the main bearing support.



DANGER

The hoist must remain attached to the block until it is firmly clamped into position. The blocks will have a tendency to tip forward until they are properly supported and clamp. When not properly supported and attached to a hoist these blocks will roll forward and out of the fixture. This will cause severe injury or death to operator.

Select the correct jacking screw to reach the block. Place the jacking screws into the jack bodies and place on the parallels in a location they will support the block from rolling forward.

Position the block clamps so the front of the shoe will clamp the block in the middle on both ends. The following illustration shows the correct triangle clamping system that should be used.

You can raise and lower the ends of the block by rotating the Hex nut located on the ends of the main bearing locators.

Triangle Clamping, V-Blocks

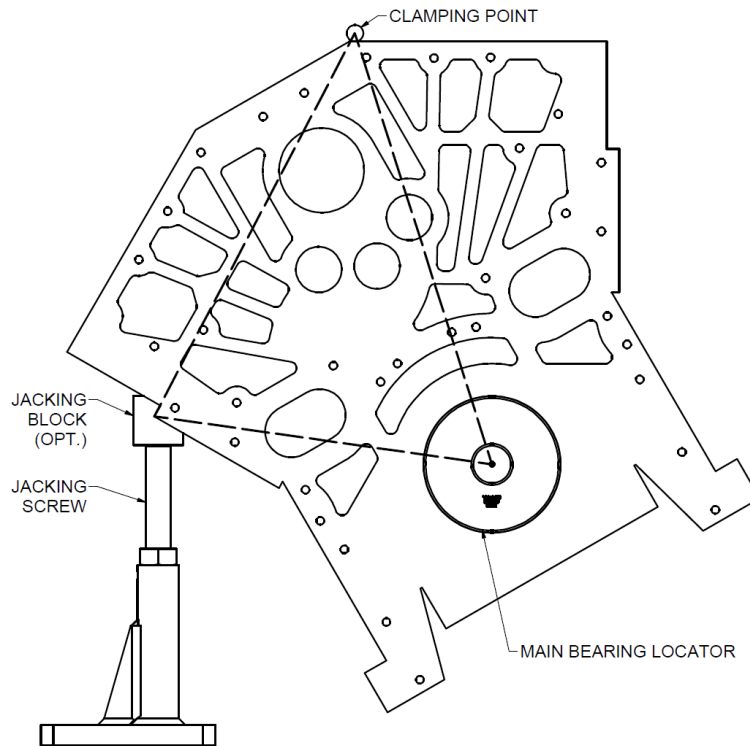

Adjust the height so the shoes rest on the clamp points. Tighten the clamp leg handles. Actuate the clamp shoes by turning their knobs. Apply pressure to the two clamps as evenly as possible to avoid tipping the block up on one side.

Block Clamp Arm

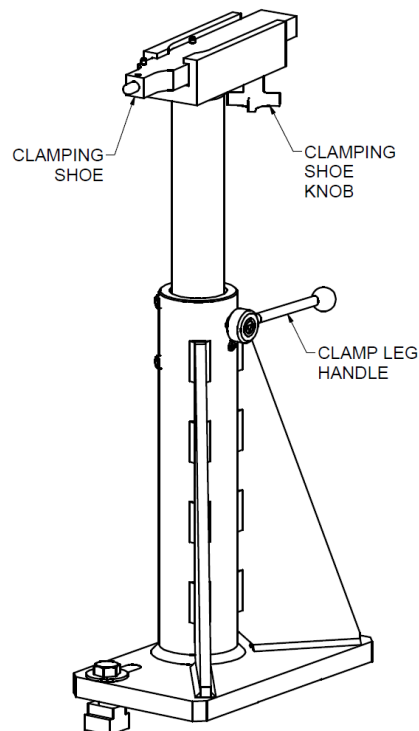

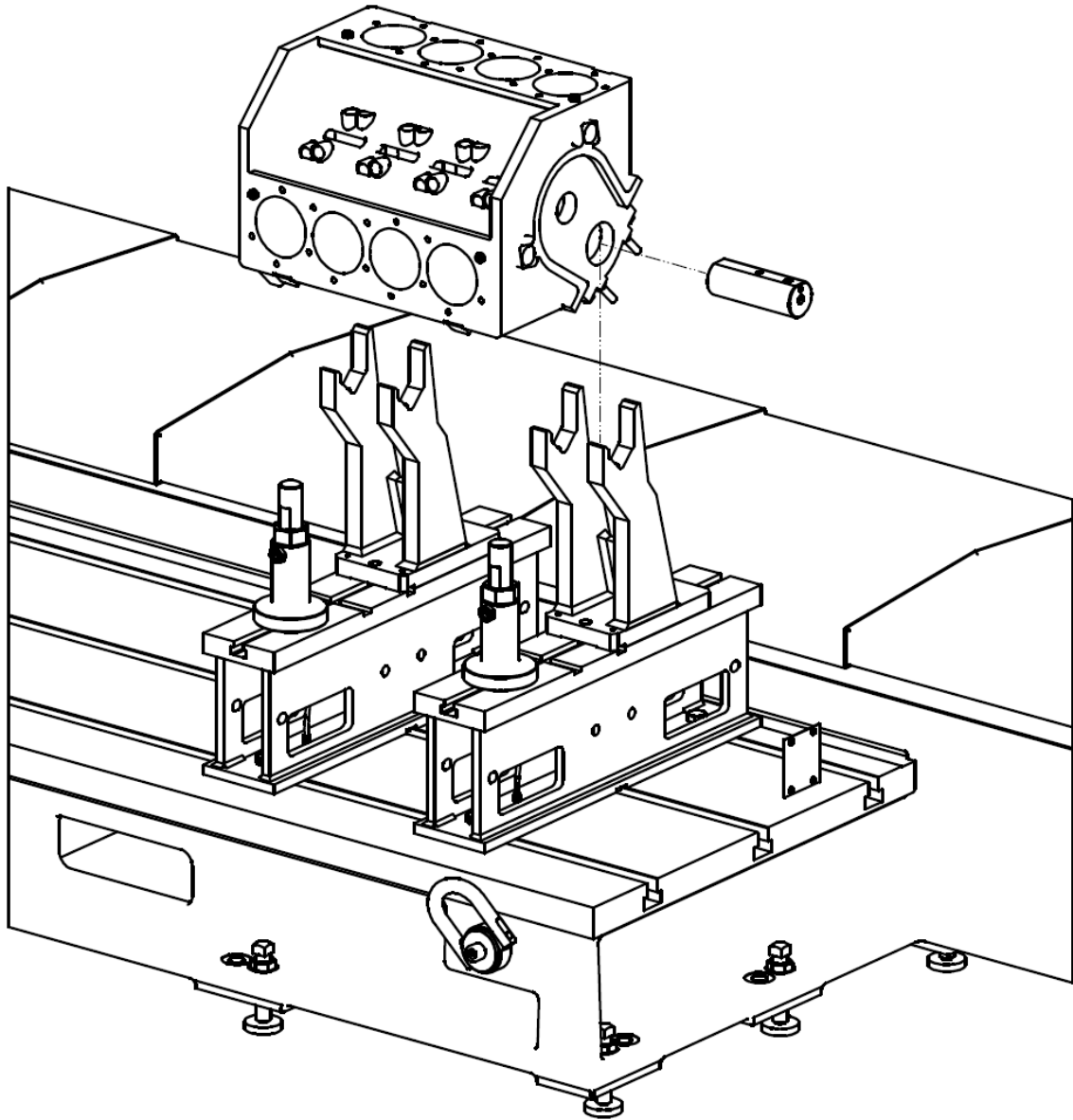

Small Diesel In Line Blocks

On these blocks it will be necessary to install the 6370Z, 10" parallels onto the bed of the machine. These parallels are keyed, place them onto the deck surface and then push them toward the rear of the machine. This will locate them evenly on the middle keyway of the machine bed. Place the two 6553F main bearing supports onto the parallels, these are also keyed and fit into the machined slots on the parallels. Use the forward machined slots. This will put the two main bearing supports in line with each other, and on centerline of the machine bed.

Position the fixtures at a distance apart equal to the outboard main journals. Tighten all bolts to lock the parallels and main bearing support into place. Select the correct size main bearing locators, and install them into the mains of the block. Notice the locators have a flat area. Installing with the flat side up will allow end to end height adjustment of the block by rotating the locator. Installing with the round side up will position the block so all machining operations are parallel and perpendicular to the main bore centerline. This simply requires leveling the block in the front to rear direction.

Note: Make sure there are no burrs or debris in the main bearing bores where they will contact the main bearing locators. This can cause the block not to clamp properly and may cause tipping or rocking of the block.



Handle these large blocks with extreme care and guidance. A block hoist is required when handling these blocks. These blocks should be lifted from the block bank surface.

Lower the block so that the locators go into the main bearing support. A clevis pin is provided to keep the locator in position on the main bearing support.

For in-line blocks, load the block with the heavier side towards the front.



The hoist must remain attached to the block until it is firmly clamped into position. The blocks will have a tendency to tip until they are properly supported and clamp. When not properly supported and attached to a hoist these blocks will roll forward or backwards and out of the fixture. This will cause severe injury or death to operator.

Select the correct jacking screws to reach the block. Place the jacking screws into the jack bodies and place on the machine bed in a location they will support the block from rolling forwards. Rough level the block using a spirit level.

The following illustration shows the correct triangle clamping system that should be used.

Triangle Clamping, In-Line Blocks

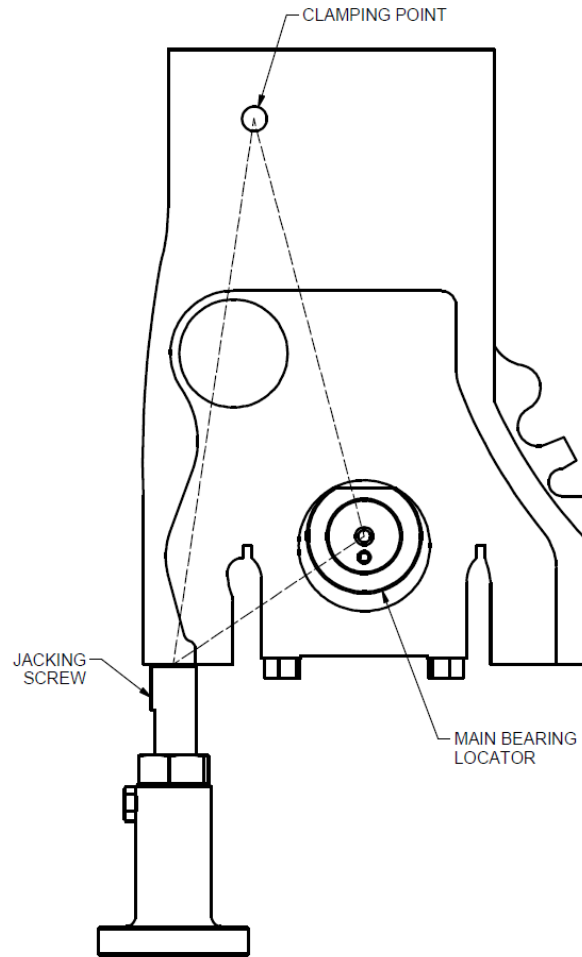

Adjust the height so the shoes rest on the clamp points. Tighten the clamp leg handles. Actuate the clamp shoes by turning their knobs. Apply pressure to the two clamps as evenly as possible to avoid tipping the block up on one side.

Be sure the clamp is below the deck surface if you to resurface the block.



Do not release the hoist or lifting device from the block until the clamping is secure.

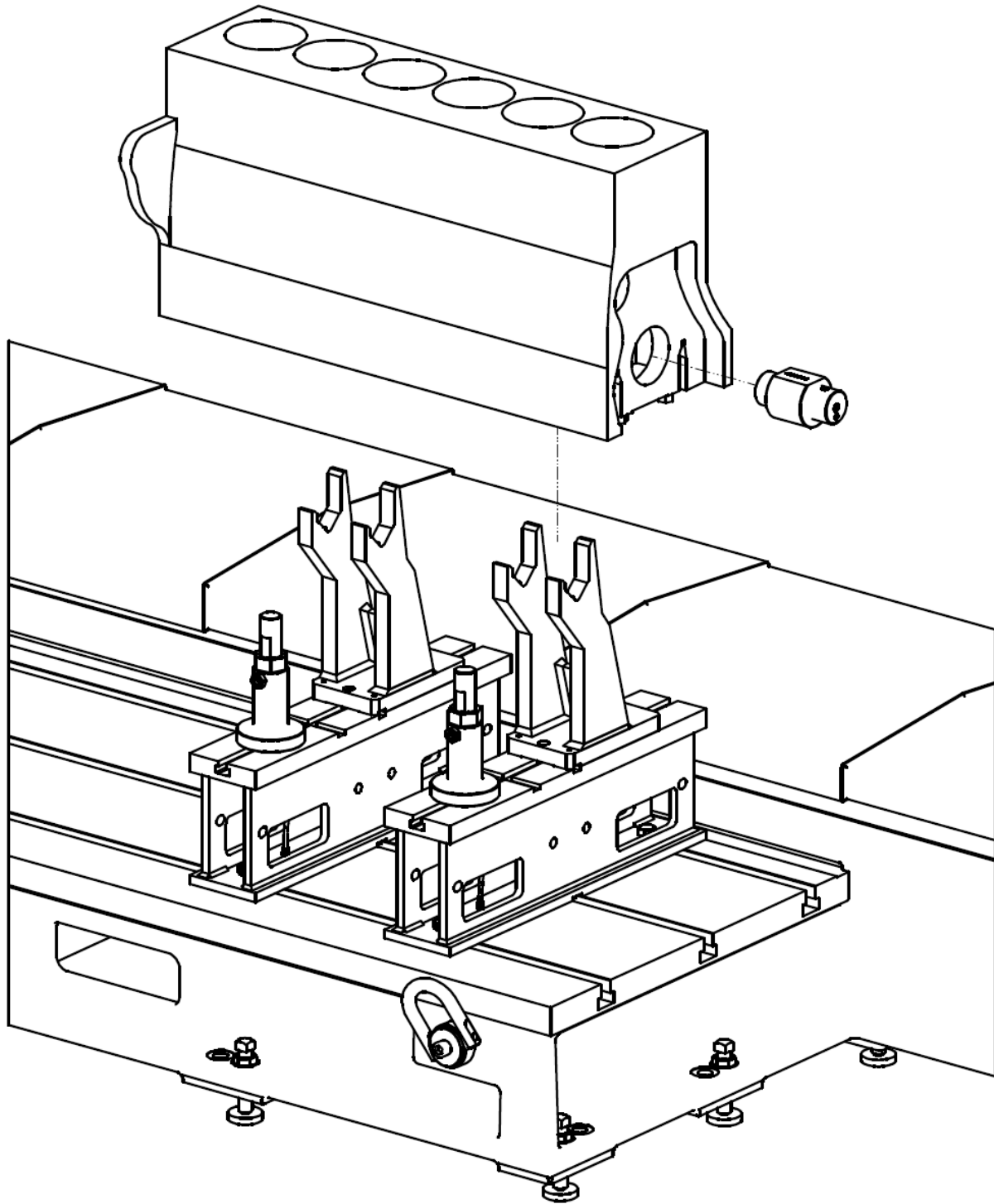

7119V Dual Axis Table Assembly

REFBUJ90-120197

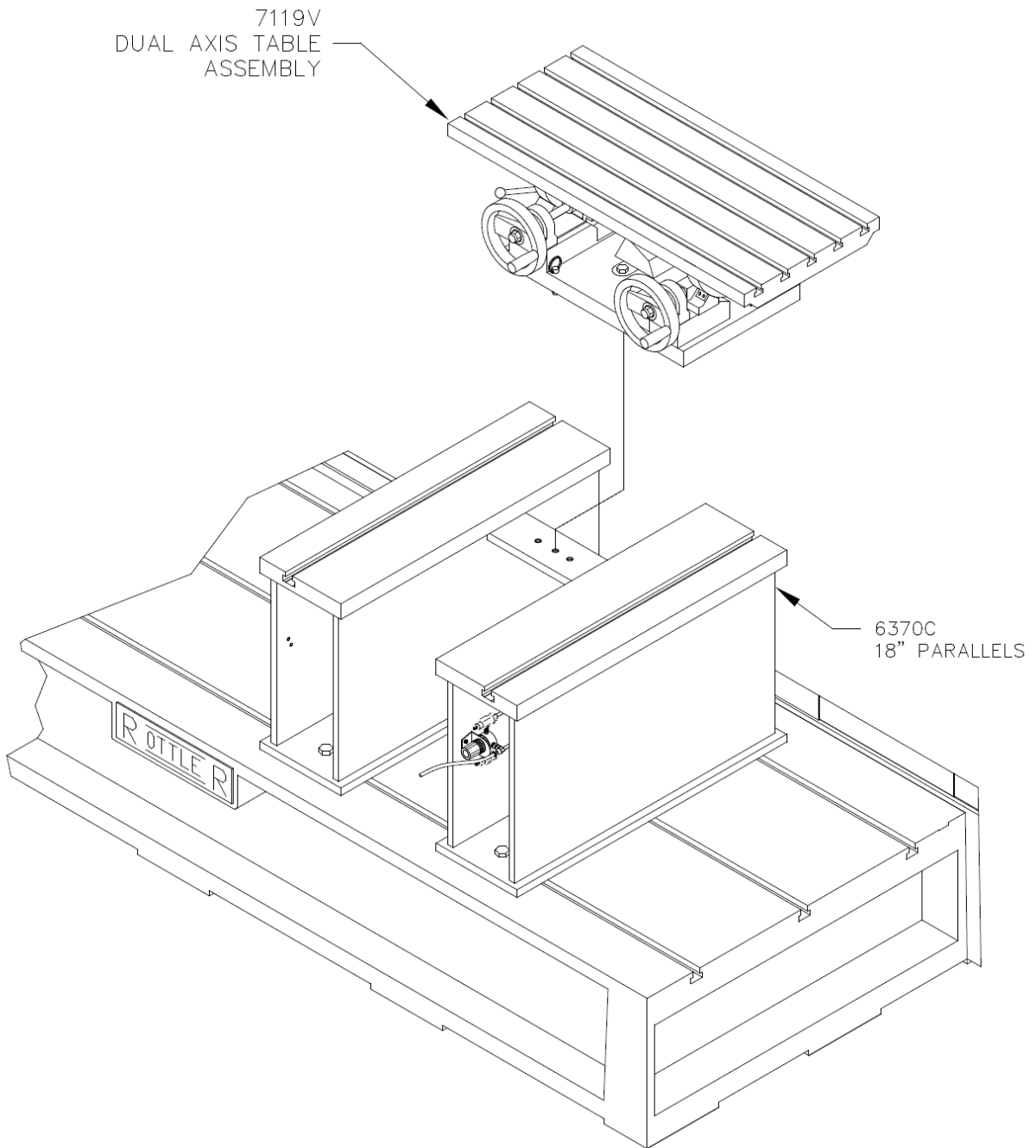

Instructions for Small In-Line Blocks

The Dual Axis Table has the capability of holding small (less than 13 1/2" from pan rail to head surface) in-line cylinder blocks for resurfacing. This will require the use of parts from the 7119P Universal Head Fixturing package.

Mounting Block to Table

There are two (2) methods for mounting blocks to the Table. Blocks with the main caps removed or with the raised main bearings can be mounted directly to the table surface. Block with the main bearing caps installed which are lower than the pan rail surface must be mounted using support blocks from the Universal Fixturing package.

Blocks with Main Caps Removed or Raised Main Bearings

Remove any burrs from pan rails of block.

Locate cone washers on table to approximately center block in path of cutter-head and 'hook' the edge of the pan rail in the rear. Clamp the block using clamp handle assembly. We suggest you install the stop rod assembly on the left-hand end of the block. This is an added safety precaution.

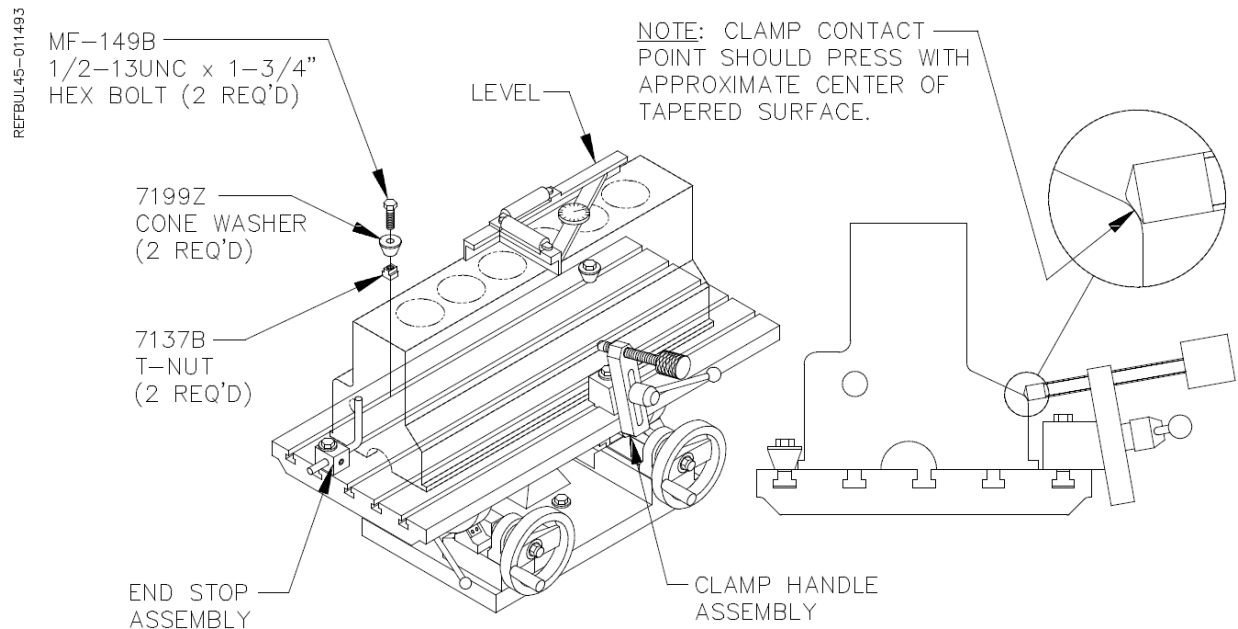

Check that all bolts and hold downs are tight. Loosen table clamp and level head surface of block in both directions. Lock table clamp and recheck block for level.

Blocks with Main Caps Installed

Remove any burrs from pan rails of block.

Position rear supports and front supports to hold block approximately centered in path of cutter-head. Generally, place the front supports closer together than the rear supports.

Place the block on the supports. Reposition the supports if necessary to clear main caps. Etc. Elevate the cones to hook the pan rail in the rear. Tighten set screws to lock cones in place. Tighten the hex bolts on the supports. Adjust the support block jack to eliminate any rocking. Lightly apply the clamp handle assembly.

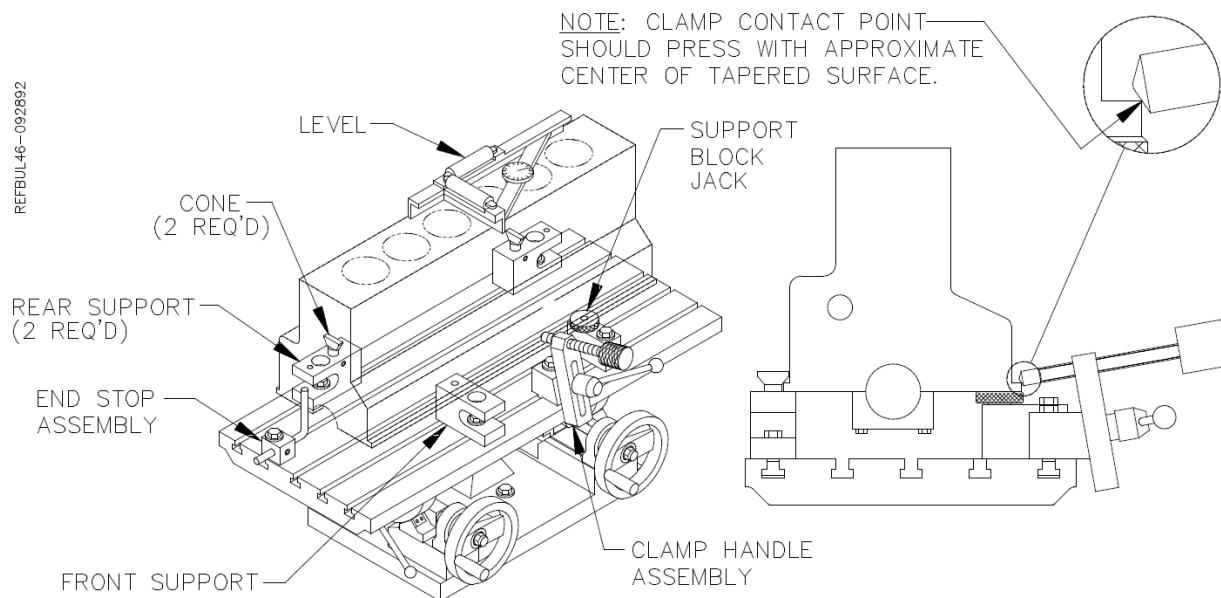

Loosen table clamp and level head surface of block in both directions. Lock table clamp. With the level still on the block tighten clamp handle assembly with appropriate clamp nose on the lower portion of a port or indent near the middle of the block. Tighten the clamp 1/8 to 1/4 turn after contacting the block. Do not over-tighten. Watch the level as you tighten to check for movement or warping. If the block moves or warps, repositioning the front supports inward will generally solve the problem. Check to see that the block cannot be moved in the fixture. We suggest that you install the stop rod assembly on the left hand end of the block. This is an added safety precaution.

Typical Head Set Up Procedure

Find the desired ports or bosses, in the head, to position cones (long or short) on rear support blocks. Measure the distance between the centerlines of these ports (bosses) within 1/16" (1mm – 5mm). Measure the distance from rear support points to front support points on the head.

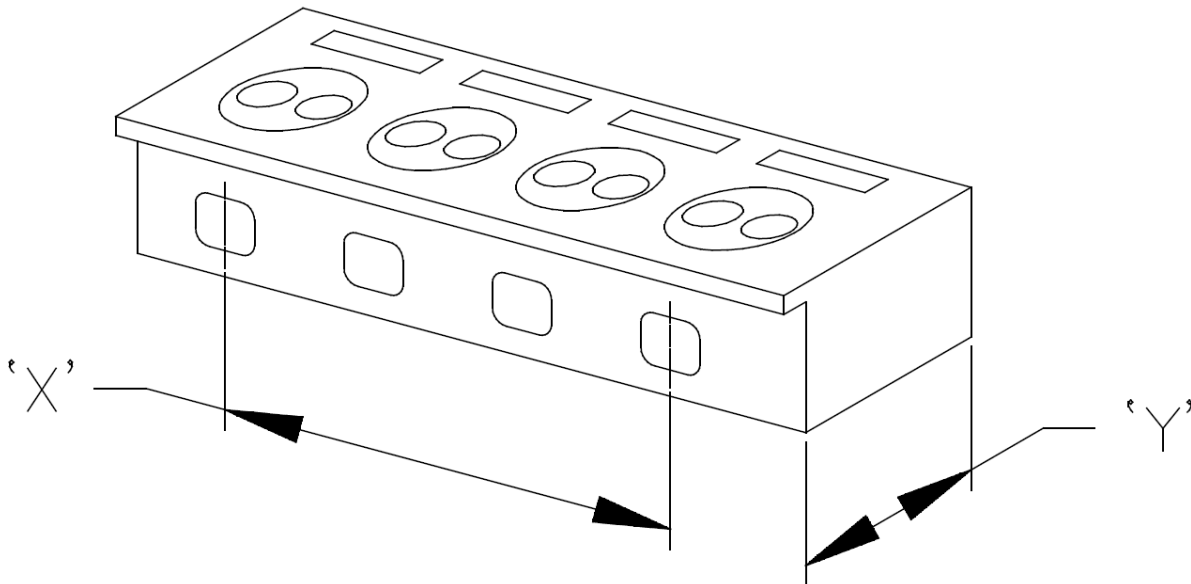

Position rear support blocks and front support blocks to hold the head approximately centered on the tabletop and spaced apart per dimensions measured in step '1' above. Generally, place the front blocks closer together than the rear blocks. If necessary, use either 2 or 4 spacers to raise the head for clearing studs or to angle the head so the cutterhead clears the head clamp handle assembly.

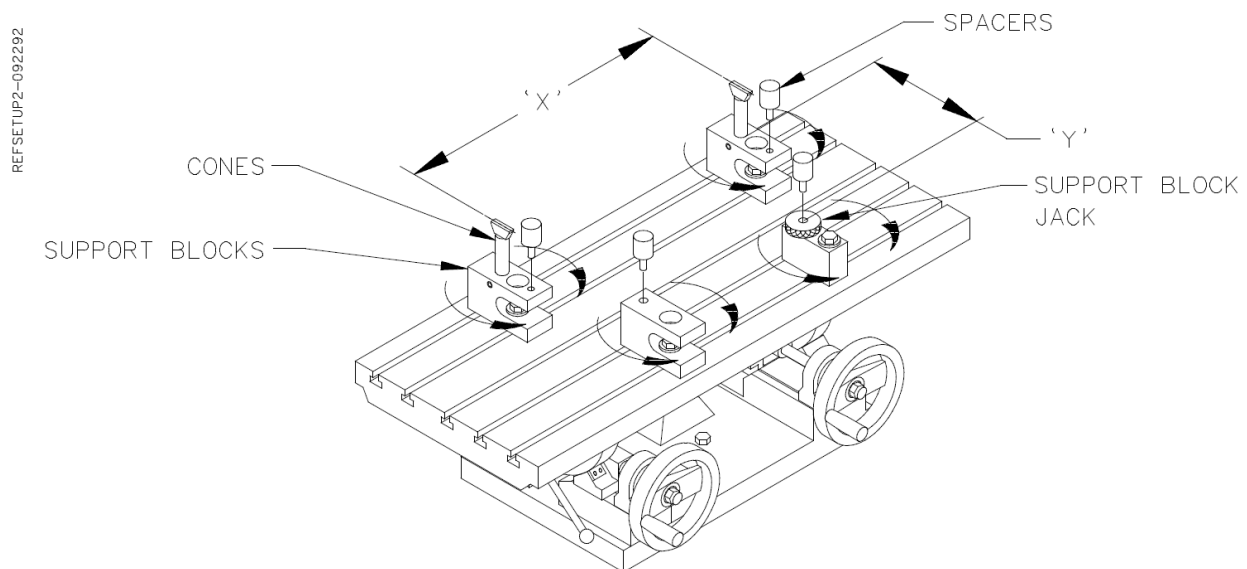

Place the head on the support blocks. Elevate the cones to 'hook' the two ports (bosses) on the head and tighten their setscrews. Adjust the position of the front support blocks if necessary. Tighten the hex bolts on the support blocks. Push the head back firmly into the cones. Adjust the support block jack to eliminate any rocking of the head. Do not tighten the head clamp handle assembly yet.

Unlock the table. Using the two hand-wheels, level the head surface to be cut. Lock the table in this position.

REFSETUP3-092292

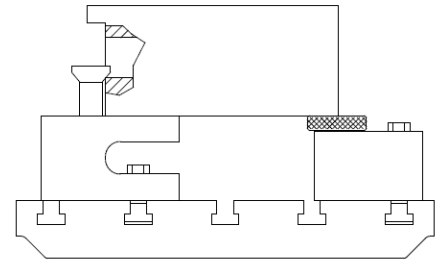
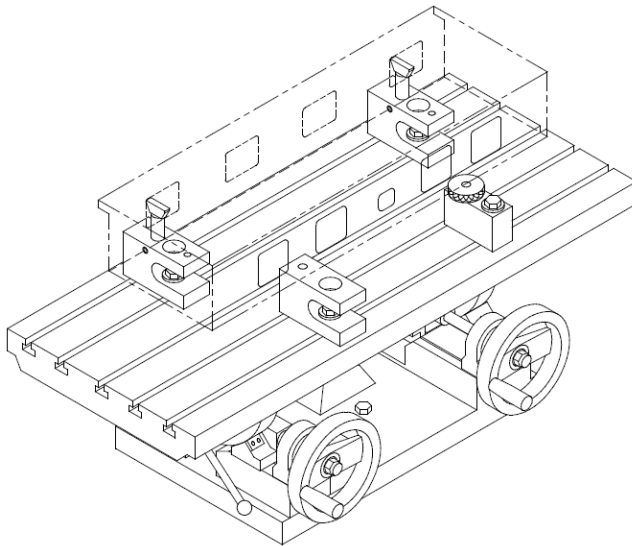

The head clamp handle assembly has a replaceable nose that pushes on the head. With the level still on the head surface, tighten the head clamp handle assembly on the lower edge of a port or indent near the middle of the head. Tighten the clamp 1/8 to 1/4 turn after contacting the head. Do not over tighten. Watch the level as you tighten to check for movement or warping. Some heads are very sensitive to support block placement, and the front support blocks may have to be moved slightly inward to prevent this warping. Check to see that the head cannot be moved in the fixture.

Slide the end stop block up against the left end of the head towards the rear. If possible, rotate the stop rod to contact a machined area on the end of the head. This will aid in loading a run of similar heads.

REFSETUP4-123192

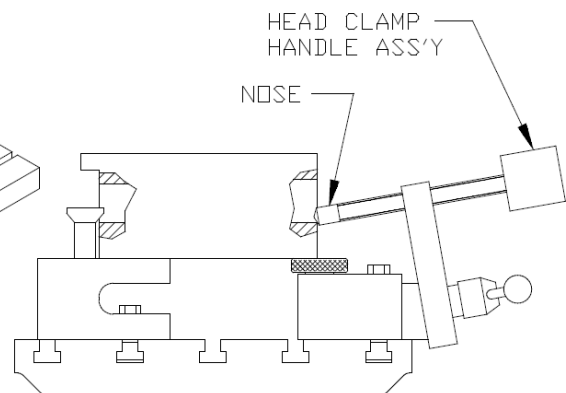
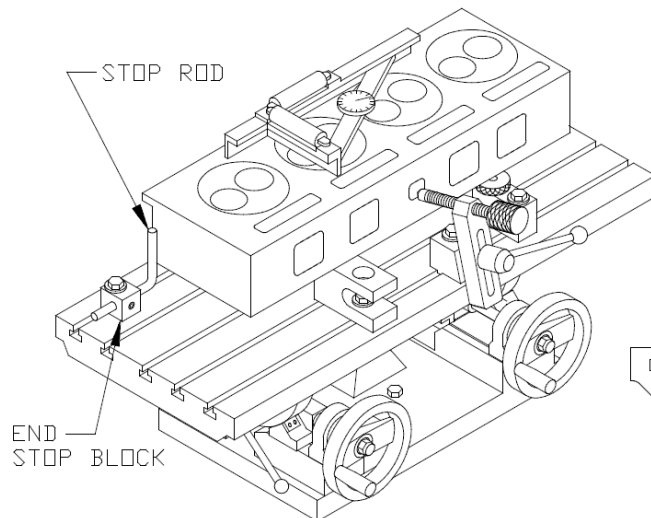
END
STOP BLOCKHEAD CLAMP
HANDLE ASS'Y

NOSE

Visually check for clearance between the cutterhead and head fixture tooling pieces, especially the head clamp handle, assembly. The head should be approximately centered in the path of the cutterhead.

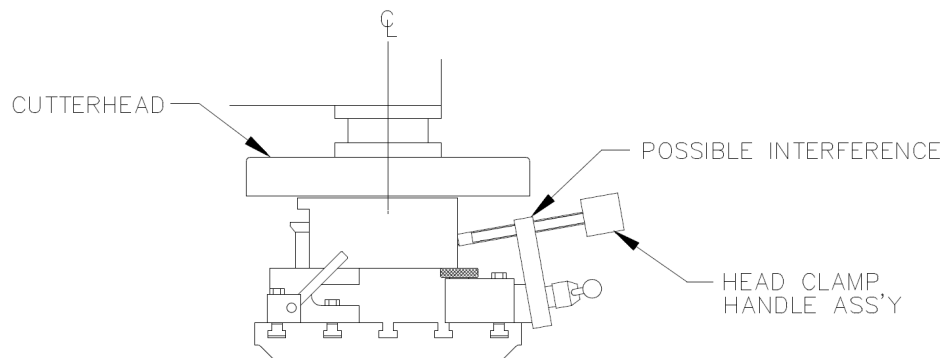

Setting Up Rottler Flycutters With Two Inserts

- Travel the spindle to the center of the machine bed.
- Go to the Rottler home screen on the machine before proceeding.
- Remove the cutter head shroud from the fly cutter. Attach a dial runout indicator to a cylinder head or engine block, etc.
- Rotate cutter head and check to see that both inserts are the same distance from the center of the spindle, within .004.
- If adjustment is necessary loosen the tool holder clamp wedge, and the height adjustment screw. Move tool in or out the required distance. Tighten the clamp wedge. Snug up the height adjustment screw. There is a set screw located at the bottom of the tool holder; it locks a dowel pin in place.
- When the in-out adjustment is set, loosen the set screw, the pin will pop out and hit the back of the slot. Tighten the set screw. This way, when a tool holder is removed and then replaced, it will be located very nearly where it was.
- Insert height will still need to be adjusted.
- Rotate cutter head and check to see that both inserts are the same height within .0015-.0003. The closer you get it the more accurate your surface will be.
- If adjustment is necessary loosen the tool holder clamp wedge, then alternately loosen and tighten the height adjusting screw and the retaining screw, until both inserts are set as desired.
- Retighten the tool holder clamp wedge and recheck both inserts.

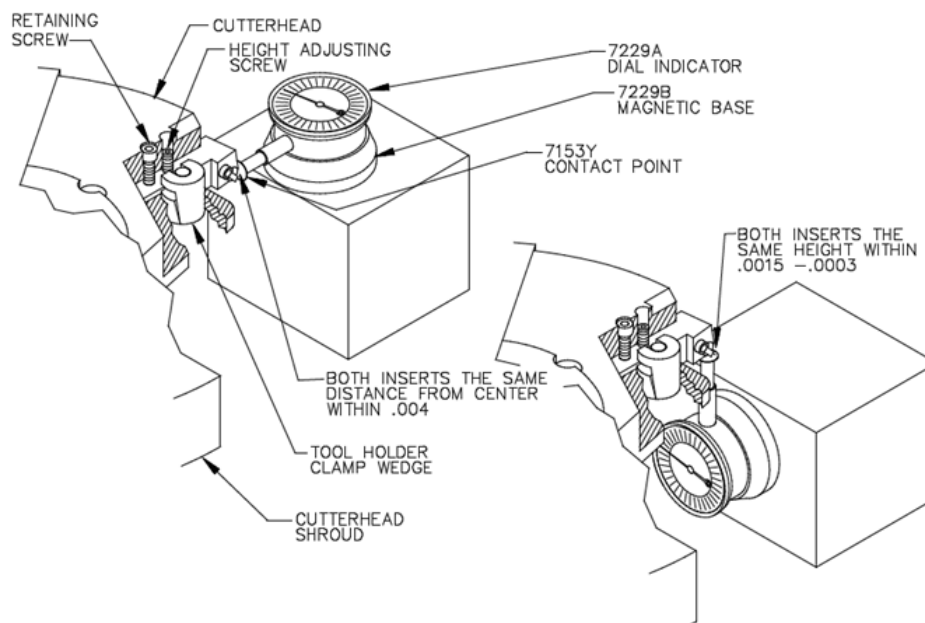

General Machine Information

The Rottler EM45 utilizes Computerized Numeric Control (CNC). From within any of the Rottler software packages the CNC control interface can be used to move the machines axis in any of the labeled directions. Below are images of the main user interfaces found in the RPATH/4C software and the Rottler Block Software program packages.

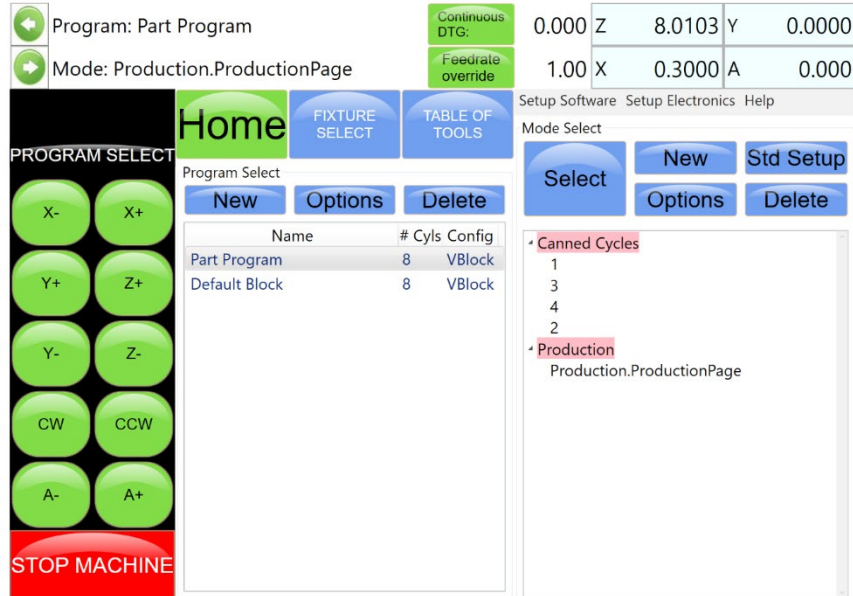

Rottler Block Software User Interface

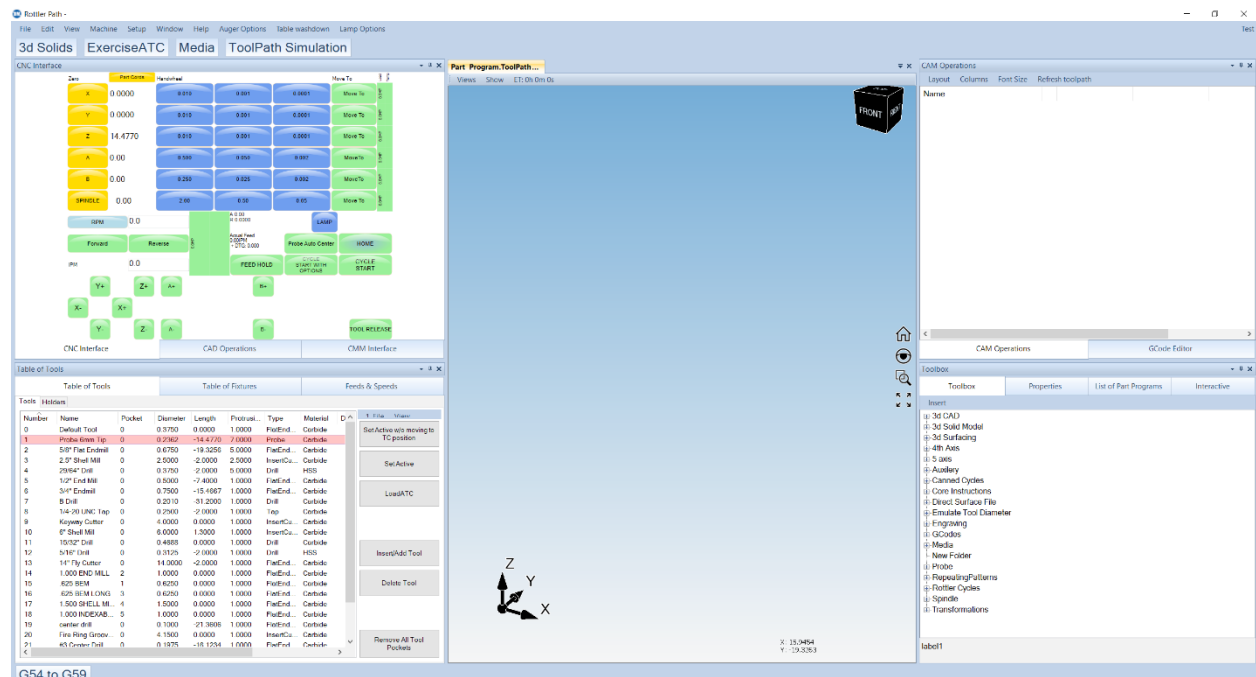

Rottler RPATH/4C User Interface

Homing

The EM45 **MUST** be homed anytime it is restarted after it has been shut down. The machine will automatically prompt the user to home the machine before being able to program and run any cycles. Homing is required so that the axes reference their current locations so that parts can be machined correctly in their respective coordinate locations.

Building Programs

NOTE: The instructions within this operator manual will cover the creation and use of block machining programs in the Rottler Block Software. For information regarding the creation and use of Rottler's Rpath/4C software packages consult the Rottler Introduction to Rpath/4C training manual that is supplied with the purchase of that software package

Create a Block Program

Within the Block Software's main screen under the program select tab, select the "NEW" button to create a new engine block file. Enter the engine block information for name, number of cylinders and block configuration and press OK when finished. On the Right side of the screen under the mode select tab, press new and select the type of operation you wish to perform to create the operation program within the engine block file. For this example, we will create a cylinder bore program.

Options

If you need to change the block configuration or name of a block that has already been created, use the Options button. This will bring up the same window as when the block was created. Resetting the Options button with a Mode highlighted will open a window where you can change the mode name. There is also a check box to allow positive number to be entered into the program where they are normally forced to a negative value.

Std (Standard) Setup

Pressing Std Setup will cause all of the available Modes to be inserted into the Modes area on the right-hand side.

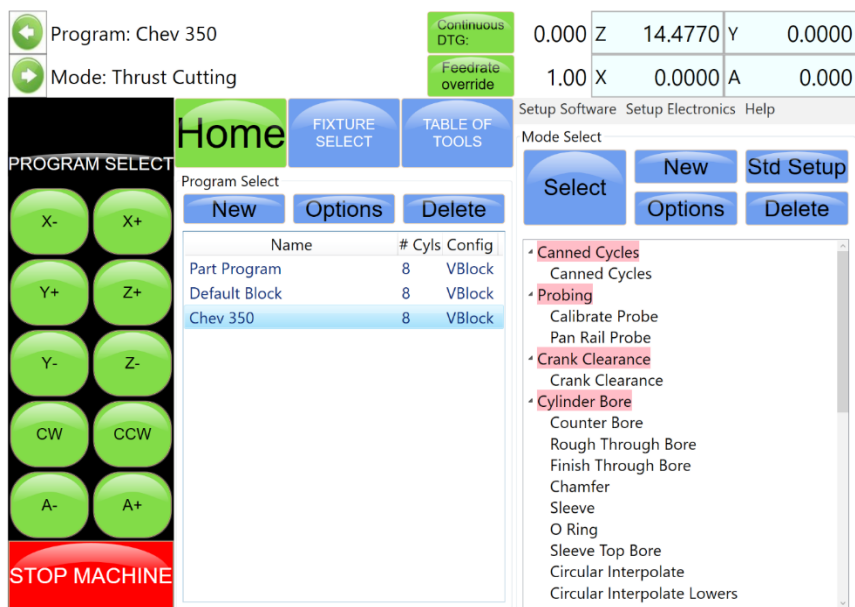

Select

Pressing Select with a Mode highlighted will open the operations screens for using the program.

Probing For Automatic Cycle

The Rottler programs can be set up to Automatically Probe a block and then set either Locations or Deck Height. This can be done on a 3 or 4 axis machine. This will also cover Setting Tool Offsets.

Setup of tools for Probing to Bore

You MUST use the Table of Tools if you want to Automatically Probe and cut it to a set size. Once done the Table of Tools Should look like the below picture.

The 100mm Probe is Tool 1

The boring bar is Tool 2.

Program: Ford 6.2L
Mode: Cylinder Bore

Continuous DTG: 0.000 Z 0.0000 Y 0.0000
Feedrate override 1.00 X 0.0000 A 0.000

Number	Name	Pocket	Diameter	Length	Protrus...	Type	Material	Description	Weight
0	Default Tool	0	0.3150	0.0000	1.0010	Retinal	Carbide		0
1	Probe 100MM	0	0.2265	0.0000	1.0010	Probe	Carbide		0
2	Boring head	0	3.5000	0.0000	1.5000	InsertCu...	Carbide		0

Buttons: CHANGE TOOL, PROGRAM SELECT, X-, X+, Y+, Z+, Y-, Z-, CW, CCW, A-, A+, STOP MACHINE, Add Tool, Remove Tool, Set Active Tool, Set Active w/o moving to TC position, Load ATC

Open the Table of Tools and double click on **Tool 1-100 mm Probe**.

Enter the Measured diameter of your probe tip various tip sizes are available as well as large offsets.

(NOTE: Setup of probe covered in the Maintenance section of this machine manual)

Exit by clicking Program Select.

Select a Boring program

Program: Ford 6.2L
Mode: Cylinder Bore

Continuous DTG: 0.000 Z 0.0000 Y 0.0000
Feedrate override 1.00 X 0.0000 A 0.000

Buttons: CHANGE TOOL, PROGRAM SELECT, X-, X+, Y+, Z+, Y-, Z-, CW, CCW, STOP MACHINE, PROBE AUTO CENTER, LAMP

Set Zeros

Fixture	Actual Position	Handwheel
X	0.0000	0.010 0.001 0.0001
Y	0.0000	0.010 0.001 0.0001
Z	0.0000	0.010 0.001 0.0001
SPINDLE	0.00	10x Coarse Fine

Feeds Speeds SSV

Spindle Load 0.0%

Feed Rate 0.0030

Spindle RPM 400.00

Buttons: MOVE TO ZEROS, CW INDEX, CCW INDEX, START SPINDLE

Notes: Tool #:2, Set Active, 1 Probe #:1, 2 Set Active

Select the Correct probe tool (1) by clicking the probe # it will bring a popup menu of the tools you have, select the probe for probing. This will ensure that your bore sizes will display correctly and will also clue you in to any problems with a oversized bore.

Select the vertical stops tab

Enter in the Probe clearance needed for the probe to clear the top of the block, then set the height needed to probe.

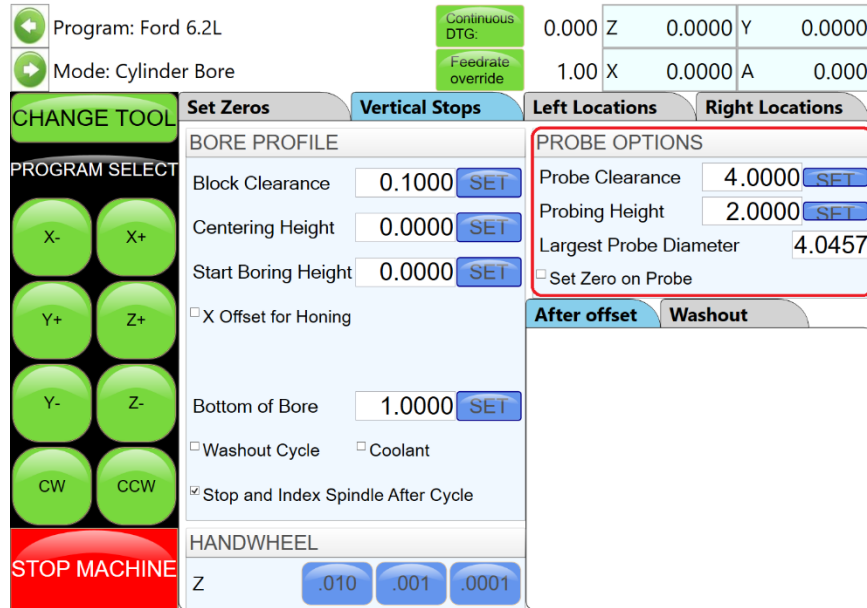

Select the Right/Left Locations tab and enter the correct blueprint values for the block.

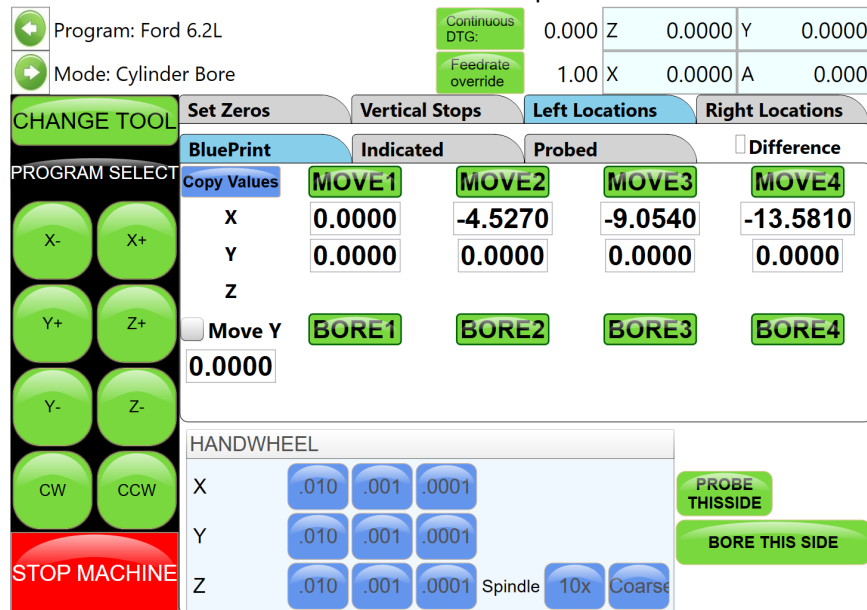

You can now then select Probe ThisSide.

This will automatically probe the side of the block you selected left/right.

You can also select Difference this will compare the results on the indicated tab or probed tab results against the blueprint tab entry.

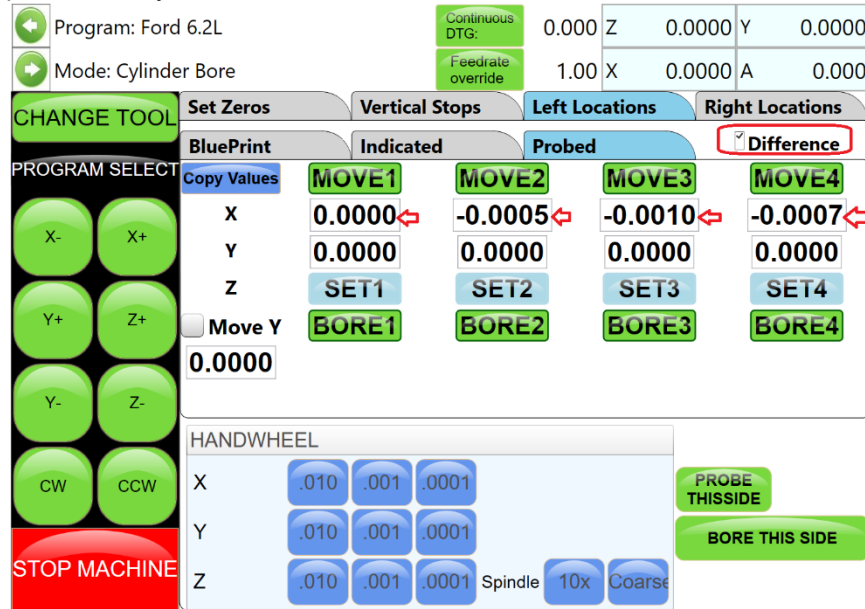

Cylinder Bore Mode 3 Axis

Select Cylinder Bore and then Rough Through Bore on the screen. This will bring up the boring program with the Set Zeros tab shown.



Setting Zeros

The purpose of setting zero points is to give the operator a specific point to build programs from. The machine also uses these zero points to run the operation. The zero points can be set at any point in the machines' travel. Every program will save it's individual zero positions, once the zero positions are set for an individual program then the operator need only to position the block in to be worked on in the same position each time to successfully run the operations.

X and Y Axis Zero's

For this example, the Engine Block Dowel Pin will be our zero point for the **X-Axis** (Horizontal) and **Y-Axis** (In/Out) axis. Using either the touch trigger probe or a test indicator, find the center of the dowel pin. Without moving the machine, **double tap** on the **X and Y buttons** directly beneath the **Fixture button** on the **Set Zeros** screen. A window will pop up asking if you want to set the selected axis, **press "yes" to zero the axis.**

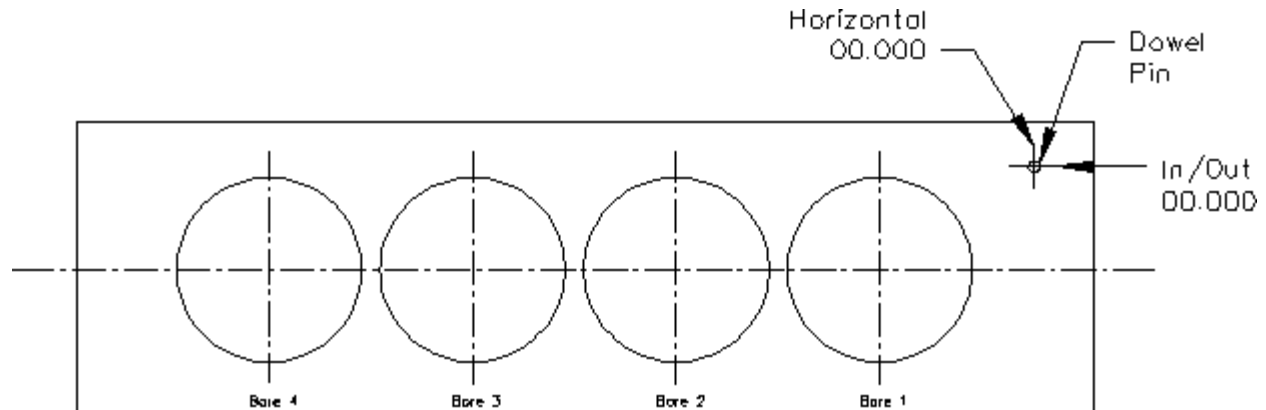

Z-Axis Zero

There are two different methods for setting the Z-axis zero for block machining

For this example, we will be using the block deck to zero our Z-axis (vertical axis). Insert a tool holder into the cutterhead you will be using to bore the block. Center the cutterhead over a cylinder. Using the Vertical Handwheel, bring the cutterhead down until the tool just touches the deck and press the Vertical Zero button. The display next to this button will go to zero. The Vertical zero has now been set.

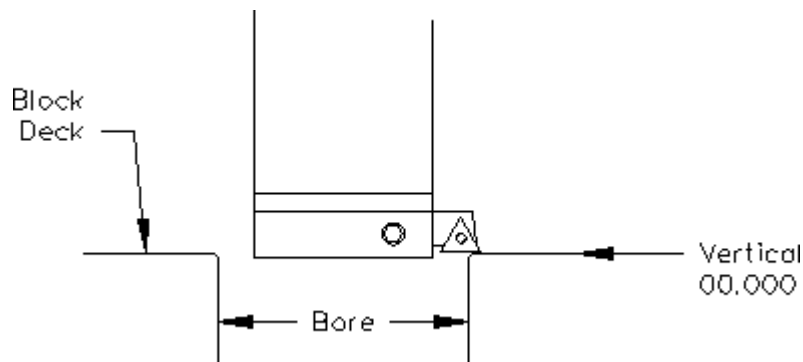

The zeros points for all axis have now been set. All the numbers entered from this point on will reference these zero positions. You are finished with the Set Zeros screen, select the next Tab to the Right, Vertical Stops.

Blueprinting Method

Even if you are not going to be boring a block to the blue print specifications it is recommended to have the Blueprint values entered. It will speed up the process of indicating and probing a block by giving the operator a close estimate of bore location.

Programming Vertical Stops

To build a program you must set the Vertical Stops for the program. This is done by filling out the boxes in the Vertical Stops Tab.

Program: Chev 350	Continuous DTG: 0.000	Z	0.0000	Y	0.0000
Mode: Cylinder Bore	Feedrate override: 1.00	X	0.0000	A	0.000

PROGRAM SELECT	Set Zeros	Vertical Stops	Left Locations	Right Locations
X- X+ Y+ Z+ Y- Z- CW CCW A- A+ STOP MACHINE	BORE PROFILE		PROBE OPTIONS	
	Block Clearance	0.0000 SET	Probe Clearance	0.0000 SET
	Centering Height	0.0000 SET	Probing Height	0.0000 SET
	Start Boring Height	0.0000 SET	Largest Probe Diameter	0.0000
	<input type="checkbox"/> X Offset for Honing		<input type="checkbox"/> Set Zero on Probe	
	Bottom of Bore	1.0000 SET	After offset Washout	
	<input type="checkbox"/> Washout Cycle	<input type="checkbox"/> Coolant		
	<input checked="" type="checkbox"/> Stop and Index Spindle After Cycle			
	HANDWHEEL			
	Z	.010 .001 .0001		

Block Clearance

This is the distance above the zero position or block deck allowing the cutterhead to move to the next bore unobstructed. If you are Blueprinting a block the number will be just enough to allow the cutterhead to clear the block deck. We recommend a .100" to .500" range for this value.

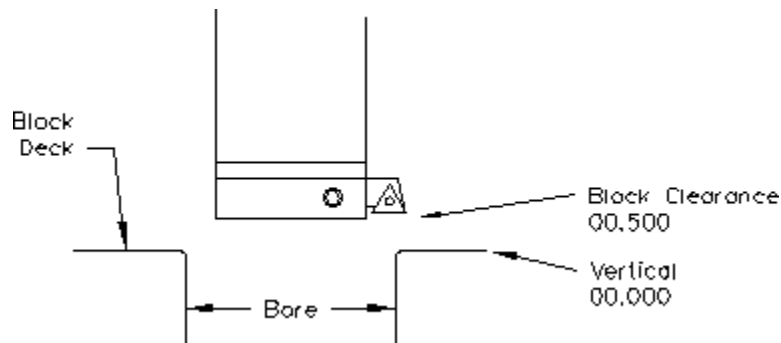

Centering Height

When Blueprinting this stop is not needed. It should be the same as the block Clearance Height.

Start Boring Height

This is the distance above zero or the block deck where you want the cutterhead to start rotating and the downward feed to start. Generally, this is just a short distance above the block deck to minimize the amount of time the machine bores through air. We recommend .030" to .200" range for this value.

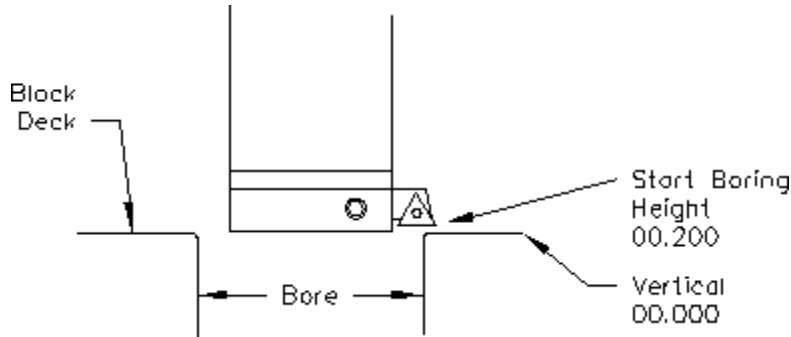

Bottom of the Bore

This is the distance below zero or the Block deck where you want the machine to stop boring and retract out of the cylinder. When the spindle retracts it will then go back to the Block Clearance position. For blue printing you can use an OEM bore length specification.

Program: Chev 350	Continuous DTG: 0.000	Z	0.0000	Y	0.0000
Mode: Cylinder Bore	Feedrate override: 1.00	X	0.0000	A	0.000

	Set Zeros	Vertical Stops	Left Locations	Right Locations
PROGRAM SELECT X- X+ Y+ Z+ Y- Z- CW CCW A- A+ STOP MACHINE	BORE PROFILE		PROBE OPTIONS	
	Block Clearance	0.5000 SET	Probe Clearance	0.0000 SET
	Centering Height	0.2000 SET	Probing Height	0.0000 SET
	Start Boring Height	0.2000 SET	Largest Probe Diameter	0.0000
	<input type="checkbox"/> X Offset for Honing		<input type="checkbox"/> Set Zero on Probe	
	Bottom of Bore	-5.4000 SET	After offset Washout	
	<input type="checkbox"/> Washout Cycle	<input type="checkbox"/> Coolant		
	<input checked="" type="checkbox"/> Stop and Index Spindle After Cycle			
	HANDWHEEL			
	Z	.010 .001 .0001		

X Offset for Honing

This feature is designed to offset the cutter at a certain height in the lower bore to cut out block web intrusions to make room for the honing process. Checking this box will add the offset parameters options to the Vertical Stops Tab.

Program: Chev 350	Continuous DTG: 0.000	Z	0.0000	Y	0.0000
Mode: Cylinder Bore	Feedrate override: 1.00	X	0.0000	A	0.000

PROGRAM SELECT	Set Zeros	Vertical Stops	Left Locations	Right Locations
X- X+ Y+ Z+ Y- Z- CW CCW A- A+ STOP MACHINE	BORE PROFILE		PROBE OPTIONS	
	Block Clearance	0.5000 SET	Probe Clearance	0.0000 SET
	Centering Height	0.2000 SET	Probing Height	0.0000 SET
	Start Boring Height	0.2000 SET	Largest Probe Diameter	0.0000
	<input checked="" type="checkbox"/> X Offset for Honing		<input type="checkbox"/> Set Zero on Probe	
	Start Offset Height	-5.2000 SET	After offset Washout AFTER HORIZONTAL OFFSET	
	Bottom of Bore	-5.4000 SET	Horizontal Offset	0.0200
	<input type="checkbox"/> Washout Cycle <input type="checkbox"/> Coolant		<input checked="" type="checkbox"/> Change Speeds At Horizontal Offset	
	<input checked="" type="checkbox"/> Stop and Index Spindle After Cycle		Feed Rate	0.0020
	HANDWHEEL		Spindle RPM	300.00
Z	.010 .001 .0001	Left Bank	Right Bank	
		Right Offset	No Offset	

Start Offset Height

This is the vertical depth at which the cutter will shift to the side to start cutting.

Horizontal Offset

This is the distance the cutter will offset from the bore center.

Change Speeds at Horizontal Offset

Often the clearance cut is much larger than the cut for the rest of the bore. For this you can check this box and enter a different RPM and Feed Rate. If a different speed and feed are not needed do not check this box and the same feed and speed will be used that was used to bore the cylinder.

For each bank (of a V Block) you can select the direction required for the offset routine.

Washout Cycle

Checking this box will open another window on the right-hand side of the screen. Here you can enter the RPM and number of revolutions that will be performed when the cutter reaches the Bottom of Bore position. This is used when a certain type of finish is required on a counter bore or the bottom of a sleeve cut. Typically, the RPM is reduced during a washout cycle.



Stop and Index Spindle after Cycle

Checking this box will cause the spindle to be indexed to the three O'clock position after the cylinder has been bored but before it retracts. It will also offset to the left before the tool is retracted. This is the default setting. You would not want this check in an operation such as Lifter Boring.

Bore Locations

To build a program you must set the X and Y axis locations for the individual cylinder bores. Since we previously set the program zero at the dowel pin location, we may now use the block blueprint dimensions to program the X and Y locations for the cylinders in reference to the dowel pin location.

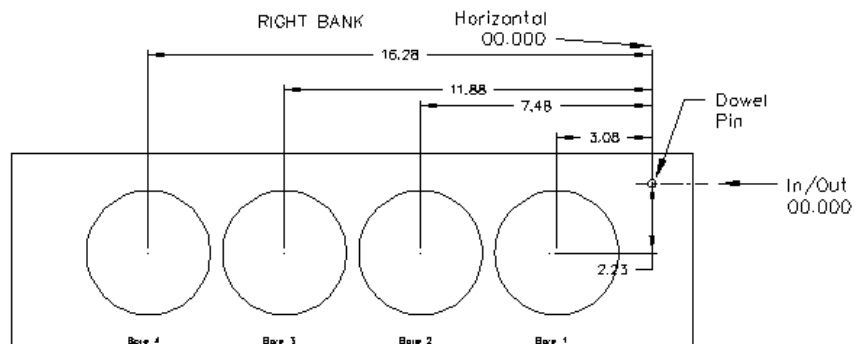
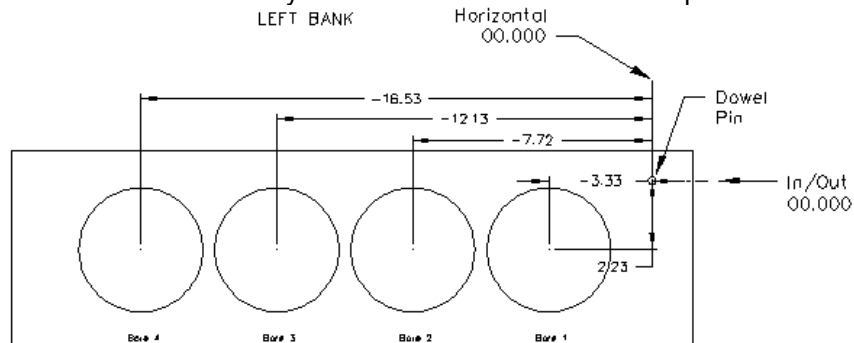

Left Locations

Program: Chev 350
Mode: Cylinder Bore

Continuous DTG: 0.000 Z 0.0000 Y 0.0000
Feedrate override: 1.00 X 0.0000 A 0.000

Set Zeros Vertical Stops **Left Locations** Right Locations

PROGRAM SELECT BluePrint Indicated Probed Difference

Copy Values MOVE1 MOVE2 MOVE3 MOVE4

X	-3.3300	-7.7200	-12.1300	-16.5300
Y	-2.2300	-2.2300	-2.2300	-2.2300
Z				

Move Y BORE1 BORE2 BORE3 BORE4
0.0000

HANDWHEEL Angle 45.000

X	.010	.001	.0001			
Y	.010	.001	.0001	A	.010	.001
Z	.010	.001	.0001	Spindle	10x	Coarse

PROBE LEFT START PROBING
BORE LEFT
START AUTO CYCLE

STOP MACHINE

Right Locations

Program: Chev 350
Mode: Cylinder Bore

Continuous DTG: 0.000 Z 0.0000 Y 0.0000
Feedrate override: 1.00 X 0.0000 A 0.000

Set Zeros Vertical Stops Left Locations **Right Locations**

PROGRAM SELECT BluePrint Indicated Probed Difference

Copy Values MOVE1 MOVE2 MOVE3 MOVE4

X	-3.0800	-7.4800	-11.8800	-16.2800
Y	-2.2300	-2.2300	-2.2300	-2.2300
Z				

Move Y BORE1 BORE2 BORE3 BORE4
0.0000

HANDWHEEL Angle -45.000

X	.010	.001	.0001			
Y	.010	.001	.0001	A	.010	.001
Z	.010	.001	.0001	Spindle	10x	Coarse

PROBE RIGHT START PROBING
BORE RIGHT
START AUTO CYCLE

STOP MACHINE

Boring a Block

Once the Vertical Stops and Left/Right location stops have all been entered the Spindle RPM and Feed Rate need to be entered. This is done on the Set Zeros screen. Once this is done you can go to the Left and/ or Right Bore location screens and bore the cylinders.

Pressing the Bore Left for Bore Right buttons Will Bore all the cylinders that have Green bore button below them.

Pressing a Bore button once will turn that button Yellow. Any Yellow button will not be bored when the Bore Left or Right button is pressed.

Double clicking any Bore button will turn all the Bore button yellow EXCEPT the one that was double click.

If your machine is equipped with a 4th axis fixture, then the Start auto cycle button will bore both the left and right banks automatically and roll the 4th axis over in between the two banks.

Indicator Method

Sometimes it is necessary to use a dial indicator to find the bore locations of an engine block when creating the program. When this is required the programming is identical to the blueprinting method, with the only exception being that we will now take advantage of the centering height option. When using this method we want to program the machine so that it goes to the rough location of the bore, where we then can use a dial indicator to find the true center of the bore to be machined before saving the X,Y location.

Block Clearance

This is the distance above the zero position or block deck allowing the cutterhead to move to the next bore unobstructed. When you are indicating the cylinders in you must have this stop set so the indicator will clear the block surface when traveling to the next cylinder.

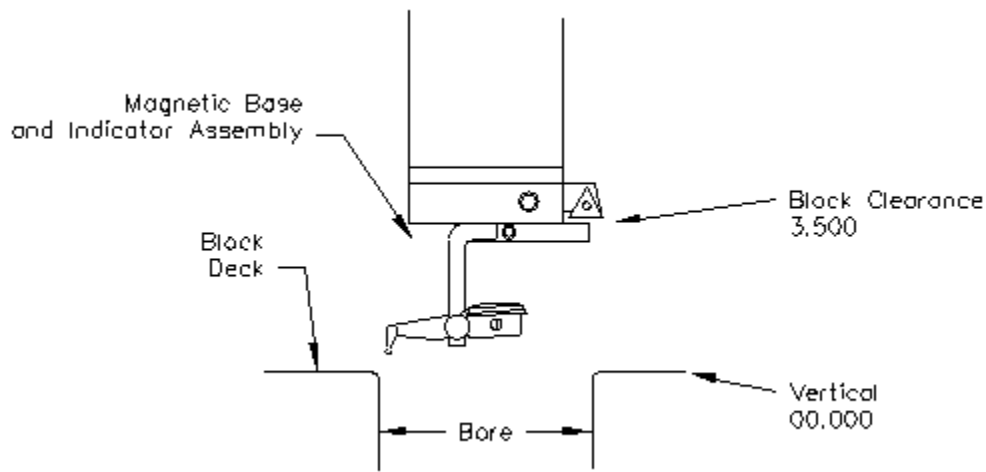

Centering Height

This is a distance above the vertical zero where you will be manually centering the block. The drawing below is a typical set up for manual centering or indicating a cylinder.

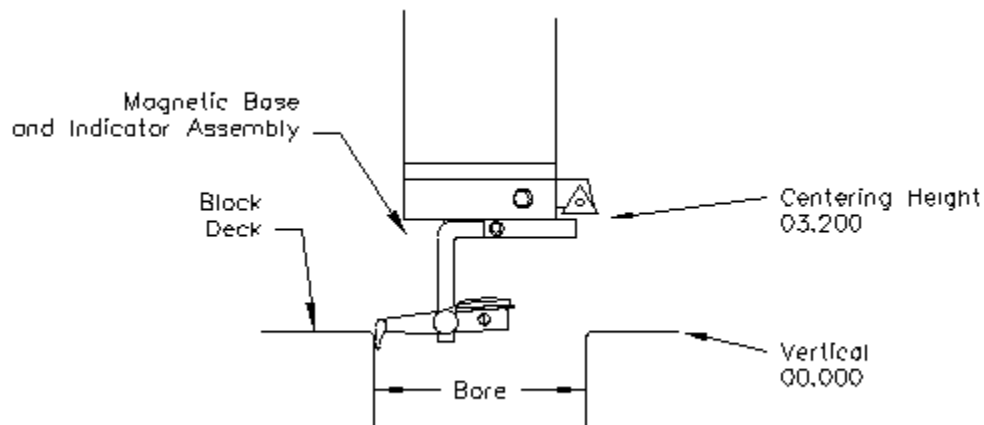

Start Boring Height

This is the distance above zero or the block deck where you want the cutterhead to start rotating and the downward feed to start. Generally, this is just a short distance above the block deck to minimize the amount of time the machine bores through air.

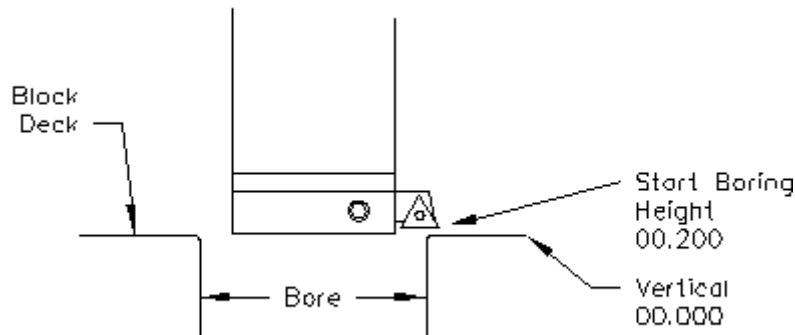

Bottom of the Bore

This is the distance below zero or the Block deck where you want the machine to stop boring and retract out of the cylinder. When the spindle retracts it will then go to the block Clearance position.

Program: Chev 350	Continuous DTG: 0.000	Z	0.0000	Y	0.0000
Mode: Cylinder Bore	Feedrate override: 1.00	X	0.0000	A	0.000

PROGRAM SELECT	Set Zeros	Vertical Stops	Left Locations	Right Locations
X- X+ Y+ Z+ Y- Z- CW CCW A- A+ STOP MACHINE	BORE PROFILE			
	Block Clearance	3.5000 SET	Probe Clearance	0.0000 SET
	Centering Height	3.2000 SET	Probing Height	0.0000 SET
	Start Boring Height	0.1000 SET	Largest Probe Diameter	0.0000
	<input type="checkbox"/> X Offset for Honing		<input type="checkbox"/> Set Zero on Probe	
	Bottom of Bore	-5.4000 SET	<input checked="" type="checkbox"/> After offset <input checked="" type="checkbox"/> Washout	
	<input checked="" type="checkbox"/> Washout Cycle <input type="checkbox"/> Coolant		WASHOUT OPTIONS	
	<input checked="" type="checkbox"/> Stop and Index Spindle After Cycle		Finish RPMS	60.00
	HANDWHEEL			
	Z	.010 .001 .0001	Finish Revolutions	2.00

The Vertical stops have now been set. You are finished with the Vertical Stops screen, select Left and/or Right Locations.

Bore Locations

To build a program you must set the X and Y axis locations for the individual cylinder bores. Since we previous set the program zero at the dowel pin location, we may now use the block blueprint dimensions to program the rough X and Y locations for the cylinders in reference to the dowel pin location.

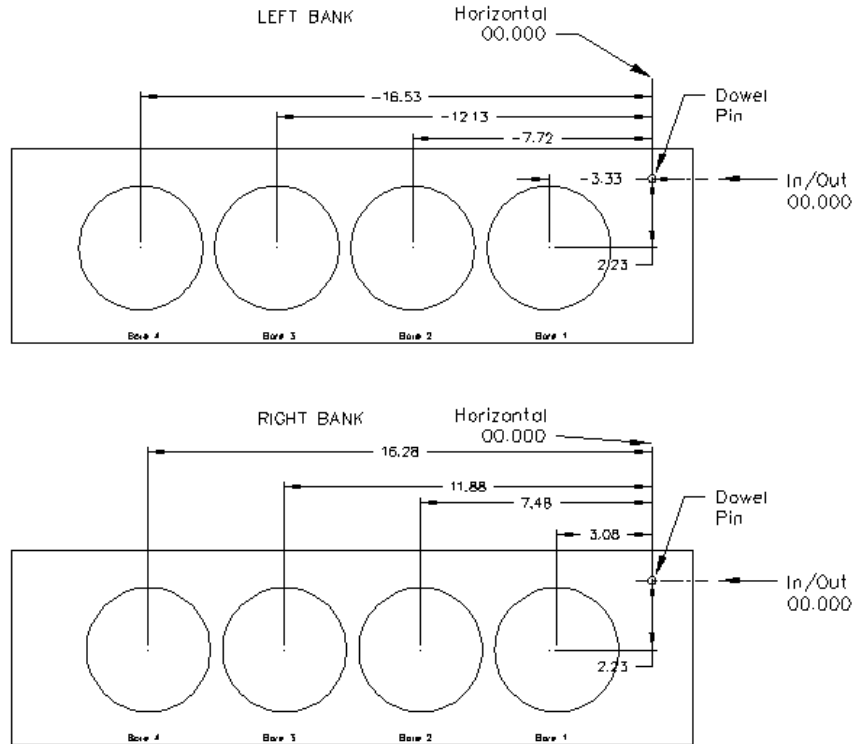

Select the left locations tab and then navigate to the indicated. If you have programmed the blueprint locations into this program, then press copy values and then blueprint. This will cause the values from the Blueprint page to be copied into the indicated page. This give you a starting point to indicate the individual cylinder from.

The screenshot shows the CNC control interface with the following elements:

- Program:** Chev 350
- Mode:** Cylinder Bore
- Continuous DTG:** 0.000
- Feedrate override:** 1.00
- Coordinates:** Z 0.0000, Y 0.0000, X 0.0000, A 0.000
- Navigation Tabs:** Set Zeros, Vertical Stops, Left Locations (selected), Right Locations
- Sub-Tabs:** BluePrint, Indicated (selected), Probed, Difference
- Coordinate Values:**

MOVE	MOVE1	MOVE2	MOVE3	MOVE4
X	-3.3300	-7.7200	-12.1300	-16.5300
Y	-2.2300	-2.2300	-2.2300	-2.2300
- Buttons:** SET1, SET2, SET3, SET4, BORE1, BORE2, BORE3, BORE4
- Handwheel:** X, Y, Z axes with resolution buttons (.010, .001, .0001) and Spindle speed (10x, Coarse).
- Angle:** 45.000
- Control Buttons:** PROBE LEFT, START PROBING, BORE LEFT, START AUTO CYCLE, STOP MACHINE

Press the Move 1 button. The machine will move to the first cylinder and stop at the centering position. Manually indicate the cylinder in using the X and Y axis handwheel options. Once the cylinder is centered press the Set 1 button. This will transfer the current position of the machine into the first set of Data Boxes. Repeat this process for all the cylinders that need to be indicated. Once the Left Locations have been indicated the same steps can be used to set the right locations.

Boring a Block

Once the Vertical Stops and Left/Right location stops have all been entered the Spindle RPM and Feed Rate need to be entered. This is done on the Set Zeros screen. Once this is done you can go to the Left and/ or Right Bore location screens and bore the cylinders.

Pressing the Bore Left for Bore Right buttons Will Bore all the cylinders that have Green bore button below them.

Pressing a Bore button once will turn that button Yellow. Any Yellow button will not be bored when the Bore Left or Right button is pressed.

Double clicking any Bore button will turn all the Bore button yellow EXCEPT the one that was double click.

If your machine is equipped with a 4th axis fixture, then the Start auto cycle button will bore both the left and right banks automatically and roll the 4th axis over in between the two banks.

Probing Method

If your machine is equipped with a Renishaw touch trigger probe, then we can use the machines probing routines to locate the block deck, cylinder locations, and set zero's automatically. When using this method we want to program the machine so that it goes to the rough location of the bore, where we then call the probing routine to probe the bore and record the calculated X,Y locations of the bore automatically.

Vertical Zero

If you have setup the table of tools and recorded tool length compensations values, then instead you can use the Probe Auto Center command and select the depth routine from within the pop up window to probe he block deck. This will feed the z-axis with down with the probe in the spindle until the probe finds the deck surfaces. After the cycle is complete the probe tip will be just touching the surface and you can double click the z axis button to set the vertical zero.



If you have not setup the table of tools, then use the blueprinting methods strategy for setting you vertical zero by touching the cutter off of the top of the block deck surface.

Programming Vertical Stops



Block Clearance

This is the distance above the zero position or block deck allowing the probe to move to the next bore unobstructed.

Centering Height

This stop is not used when you are using the probing feature. It is recommended that it be set to the same value as the Block Clearance.

Start Boring Height

This is the distance above zero or the block deck where you want the cutterhead to start rotating and the downward feed to start. Generally, this is just a short distance above the block deck to minimize the amount of time the machine bores through air.

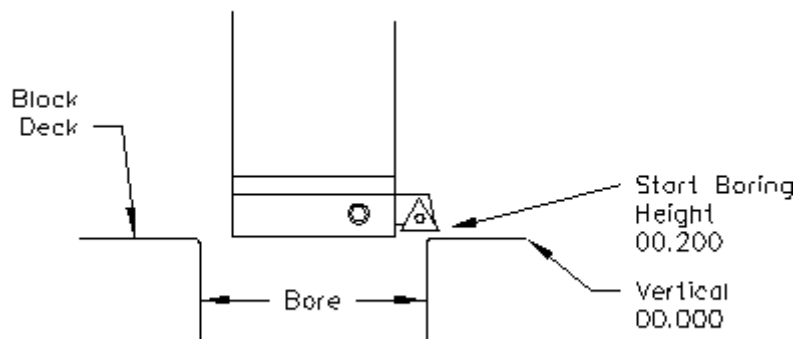

Bottom of the Bore

This is the distance below zero or the Block deck where you want the machine to stop boring and retract out of the cylinder. When the spindle retracts it will then go to the block Clearance position.

Probe Height

Using the handwheel bring the Probe down to the location in the cylinder you will be probing. Press the SET button next to Probe height. This will set the probing height position.

Using the handwheel move the probe up until it can safely move horizontal to the next cylinder. Press the SET button next to Probe Clearance. This will set the clearance height.

The Vertical stops have now been set. You are finished with the Vertical Stops screen, select Left and/or Right Locations.

Program: Chev 350	Continuous DTG: 0.000	Z	0.2000	Y	0.0000
Mode: Cylinder Bore	Feedrate override: 1.00	X	0.0000	A	0.000

PROGRAM SELECT	Set Zeros	Vertical Stops	Left Locations	Right Locations	
X- X+ Y+ Z+ Y- Z- CW CCW A- A+ STOP MACHINE	BORE PROFILE				
	Block Clearance	0.2000	SET	Probe Clearance	0.2000 SET
	Centering Height	0.1000	SET	Probing Height	-0.4667 SET
	Start Boring Height	0.1000	SET	Largest Probe Diameter	0.0000
	<input type="checkbox"/> X Offset for Honing			<input type="checkbox"/> Set Zero on Probe	
	Bottom of Bore	-5.4000	SET	<input checked="" type="checkbox"/> After offset <input type="checkbox"/> Washout	
	<input checked="" type="checkbox"/> Washout Cycle	<input type="checkbox"/> Coolant			
	<input checked="" type="checkbox"/> Stop and Index Spindle After Cycle				
	HANDWHEEL				
	Z	.010	.001	.0001	

Bore Locations

To build a program you must set the rough X,Y locations for the individual cylinder bores.

Select Left Locations and the Blueprint. Program the blueprint values (or close approximation) into the Horizontal and In/Out stops. Do the same for the Right Locations.

Select the Left Locations tab and then the probed tab. You can probe each cylinder individual by pressing the associated Probe button or you can probe the entire bank by pressing the Probe Left Button.

Probe Auto Center

This feature is located on the Set Zero page. This allows easily find the center of a hole or cylinder. Roughly place the probe in the center of a cylinder. Press Probe Auto Center. The cylinder will be probed in 4 places, when finished the probe will move to the center of the probed cylinder. Pressing Horizontal and In/Out zero will then establish the center of that hole.

Automatic Probing Procedure

The probe will move to the center of the cylinder to be probed. It will then move to the right at a slow rate until the side of the cylinder is touched, it will then back off slightly and touch the same spot again to confirm position. The probe will then touch off the cylinder in three more spots and retract from cylinder.

As each cylinder is probed the Probed Diameter, Horizontal and In/Out positions will be placed into the Data Boxes for the corresponding cylinder.

Press the Right Locations tab and repeat the above procedure for the cylinders to be probed on the right bank.

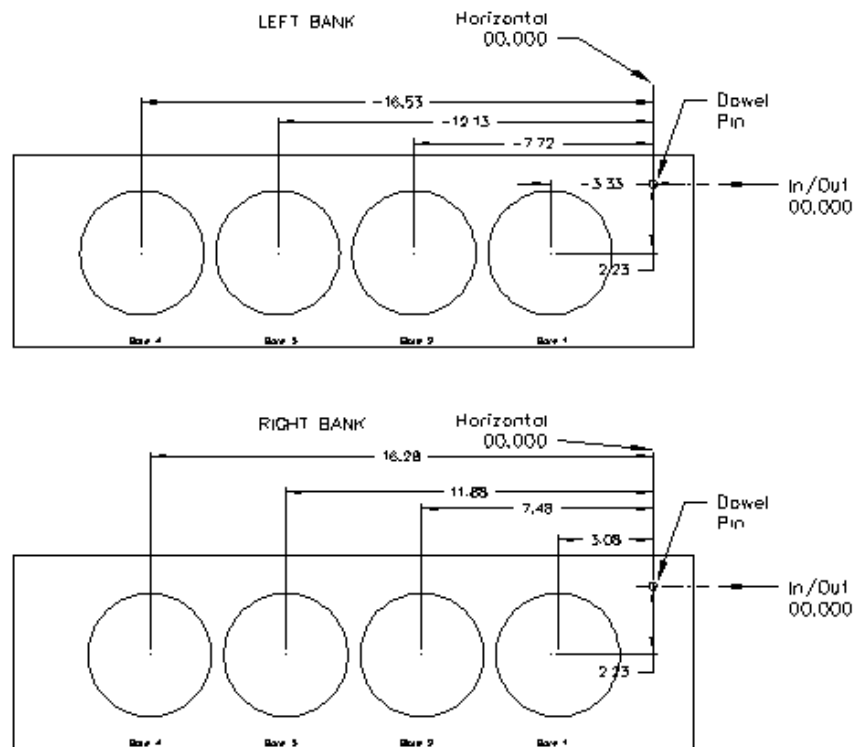

Boring a Block

Once the Vertical, Horizontal, and In/Out stops have all been entered the Spindle RPM and Feed Rate need to be entered. This is done on the Set Zeros screen. Once this is done you can go to the Left and/or Right Bore location screens and bore the cylinders.

Pressing the Bore Left for Bore Right buttons Will Bore all the cylinders that have Green bore button below them.

Pressing a Bore button once will turn that button Yellow. Any Yellow button will not be bored when the Bore Left or Right button is pressed.

Double clicking any Bore button will turn all the Bore button yellow EXCEPT the one that was double click.

Cylinder Bore Mode 4th Axis

NOTE: The program with the 4th axis installed works basically the same as the 3-axis mode. ONLY the differences in operation and screens will be discussed here. Carefully read through the 3 Axis mode and then the 4th axis mode for operation and building programs.

Select Cylinder Bore and then Through Bore on the control panel. This will bring up the boring program with the Set Zeros tab shown.

Setting Zeros

The purpose of setting zero points is to give the operator a specific point to build programs from. The machine also uses these zero points to run the program from. The zero points can be set at any point in the machines' travel. Each axis (except the Spindle rotation) will need to have a zero-point set for the machine to operate from.

4th Axis (Rotational) Zero

The Zero position for the 4th (Rotational) Axis should be preset from the factory. If the zero needs to be reset use the following procedure.

There are three (3) flats cut onto the Head Stock Plate. Use the middle flat to set the rotational zero. Using an indicator off of the spindle indicate the middle flat to Zero all the way along it. Use the 4th Axis hand wheel to do this. When the middle flat is indicated in press the 4th Axis Zero button. Your 4th (Rotational) Zero is set.

Finding the In/Out (Y) Axis Zero with 4th Axis

The Head Stock Plate has a hole in it next to the Middle Flat. This hole is centered on the center of the Main and Cam locator shafts.

Building Programs with the 4th Axis

Program are built the same as in the 3 Axis mode with the exception of setting the Angle for each Bank. The Left and the Right Locations page each have an Angle Data Box. Here you enter the angle of each bank from the 4th Axis (Rotational) zero position. The zero position is with the Cam and Crank Locators lined up vertically.

Example: On a Chevy 350 the Left bank would be positive 45 Degrees and the Right Bank would be a negative -45 Degrees.

Setting Vertical Clearance with 4th Axis

It is very important when setting your Vertical and Probe Clearance height that you be sure to account for the Roll Over of the block from bank to bank. When in an automatic program the block will roll from the left Bank to the Right bank at the Left Bank Bore1 position. It will also rotate from the Bore1 position then going from Right Bank to Left.

Table of Tools for 3 and 4th Axis Bore Mode

NOTE: The Table of Tools is not needed to run the Rottler automatic programs. It is recommended that it not be used except by the advanced operator.

Building a Program with Table of Tools

Build the program as described above for 3 and 4 Axis programs using the same vertical zero locations.

Put the tools to be used into the Table of Tools as described in Chapter 2. In Bore mode you are not referencing another vertical location such as the Crank centerline so the Z Touch off Location will remain at zero.

Assigning Tools

Tools to be used in the boring operations are set on the Set Zeros page. To select a Tool, double click on Tool # on the right side of the screen. This will bring up the Table of Tools window. Highlight the tool you will be using, such as 2.9 Production Stub and select OK.

Do the Same to select the Probe you will be using, such as 100mm Probe.

NOTE: The Tool highlighted in red is the currently Active tool.

The screenshot displays the CNC control interface with the following elements:

- Program Information:** Program: Chev 350, Mode: Cylinder Bore.
- DTG and Feedrate:** Continuous DTG: 0.000, Feedrate override: 1.00.
- Coordinates:** Z: 0.2000, Y: 0.0000, X: 0.0000, A: 0.0000.
- Set Zeros Page:** Includes buttons for X-, X+, Y+, Z+, Y-, Z-, CW, CCW, A-, A+, and a red STOP MACHINE button.
- Table of Tools Window:** A table listing various tools with columns for Number, Name, Picket, Diameter, Length, Program, Type, Material, and Dia. Tool 21 (2.9 Prod Stub) is highlighted in red.
- Handwheel:** Buttons for 0.010, 0.001, 0.0001, 10x, Coarse, Fine, and .100.
- Right Locations:** Move To buttons for Tool #0 and Probe #0.
- Feeds Speeds:** Spindle Load: 0.0%, Feed Rate: 0.0030, Spindle RPM: 400.00.
- Control Buttons:** MOVE TO ZEROS, CW INDEX, CCW INDEX, START SPINDLE, COOLANT, AUGER, LAMP, and PROBE AUTO CENTER.

Mill Mode, 3-Axis

Mill Cycle

The mill cycle can be used for programming straight line toolpaths such as what is required for creating a surfacing/decking routine. From the mode select are in the main screen, select new and then select the mill cycle operation from the pop-up window. Once created, enter the mill cycle operations by selecting it in the mode select box.

PROGRAM SELECT	Set Zeros	Operation	Left Deck Probe	Right Deck Probe	Notes	
X-	X	Actual Position	Handwheel	Move To	Tool #:0	
X+	X	0.0000	0.010	0.001	0.0001	Set Active
Y+	Y	0.0000	0.010	0.001	0.0001	Set Active
Z+	Z	14.6770	0.010	0.001	0.0001	Probe #:0
Y-	SPINDLE	25.92	10x	Coarse	Fine	Set Active
Z-	A	0.000	.100	.010	.001	Set Active
CW	B	0.000	.100	.010	.001	
CCW						
A-	Feeds Speeds	SSV				
A+	Spindle Load	0.0%				
	Feed Rate	0.0030				
	Spindle RPM	250.00				
STOP MACHINE	PROBE AUTO CENTER	COOLANT	AUGER	LAMP		

Setting Zeros

The purpose of setting zero points is to give the operator a specific point to build programs from. The machine also uses these zero points to run the program from. The zero points can be set at any point in the machines' travel. Each axis will need to have a zero-point set for the machine to operate from.

Horizontal Zero (X-axis)

For this example, we are going to set the Horizontal Zero (X-axis) at the point where the selected fly cutter is approximately $\frac{1}{4}$ " passed the right-hand side of the block to be machined.

In/Out Zero (Y-axis)

For this example, we are going to set the In/Out Zero at the center line of the work piece.

Vertical Zero (Z-axis)

For this example, the Vertical Zero will be at the deck height of the work piece.

Feeds and Speeds (IPR/RPM)

The spindle RPM and Feed rate in IPR can be set in the lower left corner of the Set Zeros tab under the Feeds Speeds box. The RPM should be set based on the recommend SFM range for the insert being used, based on the material of the block being machined. Feed rate should be set based on the insert geometry, and surface finish requirements of the block to be machined.

Manual Procedure for Setting Vertical and Horizontal Zero's (Z-axis/X-axis)

Start the spindle. Select the .001" increment for the Z-axis handwheel and move the spindle down until you can hear or see the cutter just touching the block. Double tap the Z button to zero the Z-axis here. Feed the cutter in the +X direction. When the cutter has cleared the block by approximately 1/4" double tap the X button to zero the X axis.

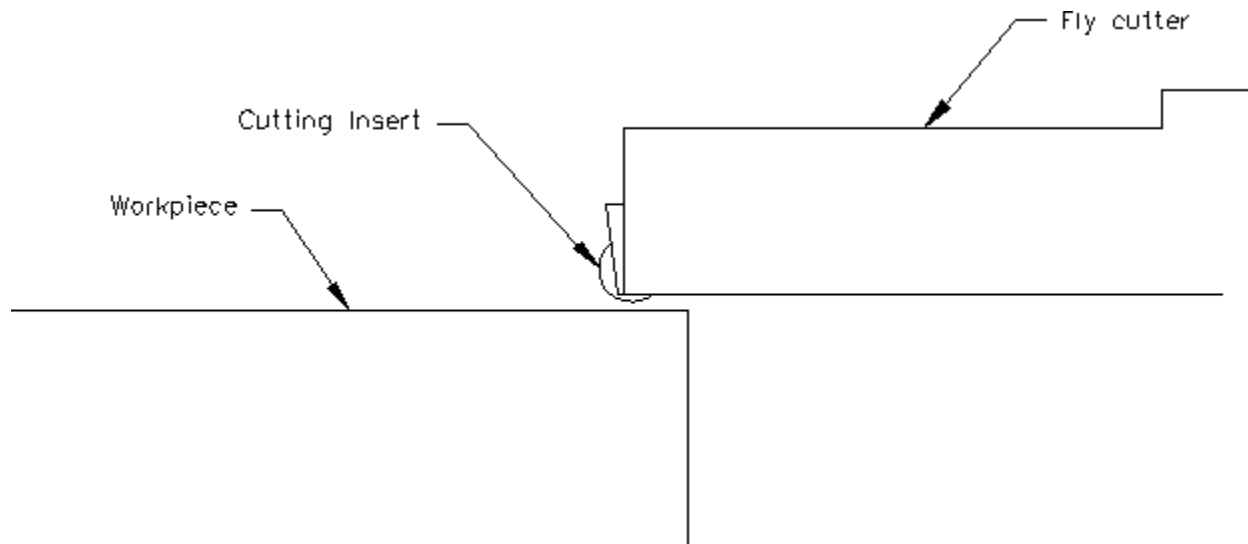

Operation

Horizontal End

This is the programs ending location in the X axis. Since we are setting up on the right-hand side of the machine this number will be negative. To set this value the operator can either jog the machine to the left end of the block so the cutter to be used is passed the end of the block and then press SET to save the current location. Or if the length of the block is known then the operator can click the box next to the SET button and type in the length of the block plus the radius of the cutter to be used for the end location.

Amount Per Pass

This is the maximum depth of cut to be performed each time the cutter makes a pass across the block surface. This is used to set the depth for any roughing cuts that will be performed.

Vertical Start

This is the Vertical Position the machine will start cutting at. This value is usually Zero which is usually the starting Deck Height.

Vertical End

This is the Vertical Position the machine will stop cutting at. It is the Total amount of material you want to remove in the Milling process.

Copy Lowest/Copy Highest

These buttons are used in conjunction with the probe with mill for probing.

Rough Settings

These values are used when taking multiple passes are necessary to remove material before finishing the block surface. Typically, the rough settings will use more aggressive cutting parameters to remove material efficiently.

Rough Feed Rate

The desired roughing feed rate in IPR

Rough Spindle RPM

The desired roughing spindle speed in RPM

Finish Cut Settings

These are the cut parameters that the machine will automatically switch to when performing the final pass

Finish Amount

The amount to be removed on the last pass.

Finish Feed Rate

The desired Finish Feed Rate in IPR.

Finish RPM

The desired Finish Spindle RPM.

A-Axis

This controls the 4th axis if machining a V-block.

Overlap Mill Settings

This is used if the cutter to be used cannot machine the entire width of the block in one pass.

NOTE: You do not need to have evenly divisible numbers in these sections. The computer will do the math to remove the maximum allowable material each pass while still using the specified finish cut settings.

Program: Chev 350	Continuous DTG: 0.000	Z	0.0000	Y	0.0000
Mode: Mill Cycle	Spindle override: 1.00	X	0.0000	A	0.000

PROGRAM SELECT	Set Zeros	Operation	Left Deck Probe	Right Deck Probe
X- X+ Y+ Z+ Y- Z- CW CCW A- A+ STOP MACHINE	End		Rough Settings	
	Horizontal End	-10.0000 <input type="button" value="SET"/>	Rough Feed Rate	0.0030
	Amount per Pass	-0.0050	Rough Spindle RPM	400.00
	Vertical Start	0.0000 <input type="button" value="Copy Highest"/>	Overlap Mill Settings	
	Vertical End	-0.0100 <input type="button" value="Copy Lowest"/>	Max Workpiece Width	0.0000
	Additional Depth	0.0000	Cutter Diameter	0.3750
	<input checked="" type="checkbox"/> Coolant		Finish Cut Settings	
	A Axis		Finish Amount	0.0020
	Left Bank Angle	45.000	Finish Feed Rate	0.0030
	Right Bank Angle	-45.000	Finish Spindle RPM	400.00
Rollover Vertical Clearance	0.0000			
Y Offset	0.0000			
		<input type="button" value="CUT LEFT"/>	<input type="button" value="CUT RIGHT"/>	<input type="button" value="START AUTO CYCLE"/>

Start Auto Cycle

Pressing this button will start the machines automatic cycle. The cycle to be run is determined by the setting on this page. If you only require one pass to be made, do not enter any values into the Rough Setting, only the Finish Cut Settings.

Mill Mode. 4-Axis

Program Additions to 3-axis Operation

The Program setup for a 4th Axis operation is largely the same as the programming for a 3-axis operation. The only difference is the addition of the A-Axis settings. When surfacing a V-block we first setup the surfacing operation on one deck and then fill out the A-axis settings to have the program repeat on the second deck.

Continuous DTG:	0.000	Z	0.0000	Y	0.0000
Spindle override	1.00	X	0.0000	A	0.000
Set Zeros					
End					
Horizontal End	-10.0000	SET			
Amount per Pass	-0.0050				
Vertical Start	0.0000	Copy Highest			
Vertical End	-0.0100	Copy Lowest			
Additional Depth	0.0000				
<input type="checkbox"/> Coolant					
A Axis					
Left Bank Angle	45.000				
Right Bank Angle	-45.000				
Rollover Vertical Clearance	0.0000				
Y Offset	0.0000				
Left Deck Probe					
Rough Settings					
Rough Feed Rate		0.0030			
Rough Spindle RPM		400.00			
Right Deck Probe					
Overlap Mill Settings					
Max Workpiece Width		0.0000			
Cutter Diameter		0.3750			
Finish Cut Settings					
Finish Amount		0.0020			
Finish Feed Rate		0.0030			
Finish Spindle RPM		400.00			

4h Axis Angles

Left Bank Angle

Enter the angle of the Left Deck. This is the angle of the block in reference to the Cam and Crank bore being lined up Vertically.

Right Bank Angle

Enter the angle of the Right Deck. This is the angle of the block in reference to the Cam and Crank bore being lined up Vertically.

Rollover Vertical Clearance

Enter the value the Fly Cutter will have to move up vertically to clear the block when it rolls over from bank to bank. Make sure the block can completely rollover when in this position for safety.

Cut Left and Cut Right

Pressing these buttons will cause the machine to run an automatic cycle (per the parameter defined in the Operations page) on the associated bank.

Start Auto Cycle

Pressing this button will start the machines automatic cycle. The cycle to be run is determined by the setting on this page. If you only require one pass to be made, do not enter any values into the Rough Setting, only the Finish Cut Settings.

Milling Using Automatic Deck Probing

The Rottler Milling program is set up to Automatically Probe the Deck height of a block and then Mill it to a set Deck Height. This can be done with both 3 and 4 axis operations.

Table of Tools for Milling

You MUST use the Table of Tools if you want to Automatically Probe the deck height and cut it to a set height. If you are unsure about how to setup the table of tools and set tool length compensation, then consult the Table of Tools section of the operator's manual before proceeding further in this section.

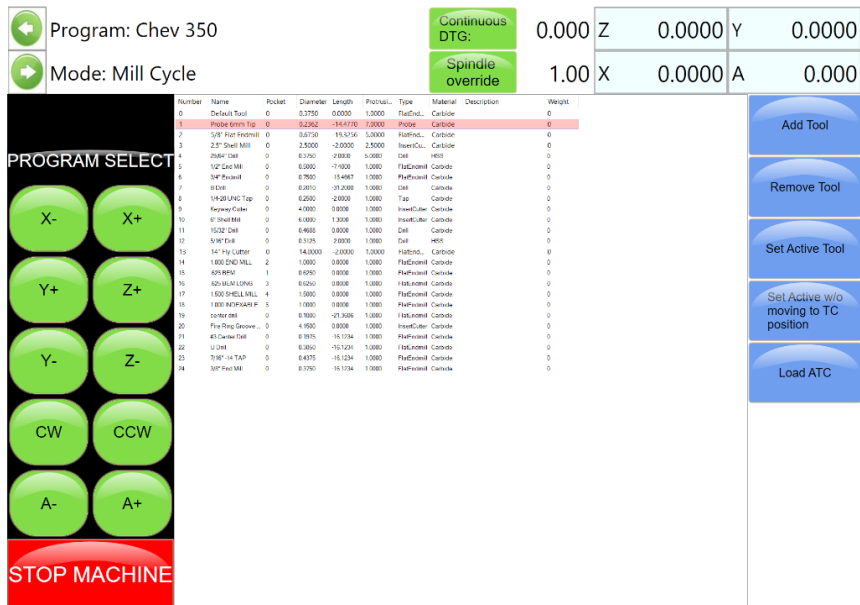

Building a Program Using the Probe and Table of Tools

Using the probe allows the programmer to setup different blocks that may require different tooling using only the probe to find locations and set zeros. Using the probe speeds up the setup time while also increasing the accuracy and precision of the blocks being processed. When surfacing we can use the probe to automatically find the lowest relative point of the surface and then use that gathered data to let the machine figure out how much material to remove.

Probe Auto Center

The probe auto center button can be found in the feeds and speeds tab within the set zeros page. Clicking this button will open the probe auto center form where the various probing routines can be called upon while jogging the machine. The Depth, Inside Diameter, and Outside diameter routines are the most used routines for performing engine work.

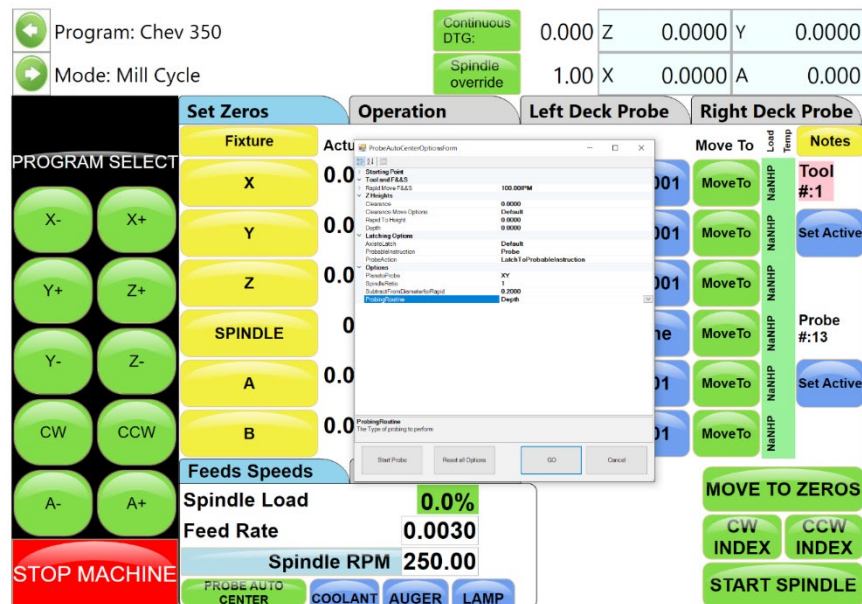

Probe Depth

Probes a surface in one point by moving down in the z-axis and stopping with the probe tip just touching the surface. When setting up a probing routine, you must run this operation and zero the z-axis while the probe tip is touching the surface to give the probe a starting reference.

Probe Inside Diameter

Probes 4 points 90 degrees offset from each other to find the center line of a circle in one plane.

Probe Outside Diameter

Probes 4 points 90 degrees offset from each other on the circumference of a circle to find the centerline in one plane.

Probing Engine Block Surfaces

To probe the engine block deck surfaces, we can use the left deck probe and right deck probe tabs from within the block software to define locations for the probe to move to and then run the depth probing routine.

Left Deck Probe

Enter the positions you want the Probe to probe here. You can physically move the probe to the locations on the bank you want to probe and hit the set button also.

Right Deck Probe

Roll the block over to the Right Bank. Enter the positions you want the Probe to probe here. You can physically move the probe to the locations on the bank you want to probe and hit the set button also.

Probe Clearance

Position in the z-axis that the probe will return to when moving between points.

Lowest Allowed

Lowest Z-axis position that the machine will lower the probe to before stopping if it doesn't contact a surface.

Auto Probing

Press the Start Probing button. The machine will first probe each programmed location on the left bank and record the height. The spindle will move to Vertical Clearance height and the block will roll over to the right bank and probe the programmed locations and record them. The block will then roll back over to the Left bank and the spindle will move to the first Left location and stop.

Auto Milling

After the points have been probed the values gathered from the probe can be copied into the depth to cut within the operation tab.

Vertical Start

Press Copy Highest next to Vertical Start. This will copy the Highest Probed point of either bank. This is the Height at which the Start Auto Cycle would start the first cutting pass.

Vertical End

Press copy lowest to copy the lowest point from the probed data into this box. This can be used to perform a minimum cleanup on the block, as the finish cut will end at the lowest probed points height. If more material is to be removed, then the amount below the lowest point that the operator would like to cut can be entered manually in the box as done in previous methods.

Program: Chev 350	Continuous DTG: 0.000	Z	0.0000	Y	0.0000
Mode: Mill Cycle	Spindle override: 1.00	X	0.0000	A	0.000

PROGRAM SELECT	Set Zeros	Operation	Left Deck Probe	Right Deck Probe
X- X+ Y+ Z+ Y- Z- CW CCW A- A+ STOP MACHINE	End		Rough Settings	
	Horizontal End	-10.0000 <input type="button" value="SET"/>	Rough Feed Rate 0.0030	
	Amount per Pass	-0.0050	Rough Spindle RPM 400.00	
	Vertical Start	0.0000 <input type="button" value="Copy Highest"/>		
	Vertical End	0.0000 <input type="button" value="Copy Lowest"/>		
	Additional Depth	0.0000	Overlap Mill Settings	
	<input type="checkbox"/> Coolant		Max Workpiece Width 0.0000	
	A Axis		Cutter Diameter 0.2362	
	Left Bank Angle	45.000	Finish Cut Settings	
	Right Bank Angle	-45.000	Finish Amount 0.0020	
Rollover Vertical Clearance	0.0000	Finish Feed Rate 0.0030		
Y Offset	0.0000	Finish Spindle RPM 400.00		
		<input type="button" value="CUT LEFT"/>	<input type="button" value="CUT RIGHT"/>	<input type="button" value="START AUTO CYCLE"/>

Start Auto Cycle

Pressing this button will start the Auto Cycle for Both Banks. First the Left bank will be cut to the set parameters. The spindle will go to the Clearance Height and Roll over to the Right bank and cut it to the set parameters. The Spindle will again go to the Clearance Height and roll over to the Left bank. The machine will go idle at this point.

Lifter Bore Mode 3 Axis

Lifter Bore programs are built the same as described in the Bore Mode 3 Axis. The differences in locating the bores and tooling will be discussed in this section.

Y-axis Zero (In/Out)

The Y-axis zero position for lifters is the center line of the Cam Bore. An easy way to find the center of the cam line is to use the electronic probe. The following is an example of this procedure. Install the probe into the holder and the holder into the spindle. Bring the probe down until it is in the approximate center of the cam Bar Vertically. Press the Vertical Zero button now (this is only a temporary Vertical Zero position). Jog the Y-axis with the handwheel to bring the probe up to the Cam Bar until it lights. Press the Y-axis zero button here. Move the spindle up enough to clear the Cam Bar, move the probe to the other side of the Cam Bar. Bring the vertical down to the zero position. Hand wheel the probe into the Cam Bar until the light comes on. Note the Y-axis position reading. Divide this reading by two. Bring the spindle up until it can clear the Cam Bar. Use the Y-axis handwheel and move the Y-axis position until it matches the divided number. This is the center line of the Cam Bar. Press the Y-axis Zero button now. The Y-axis zero position has been set. The following illustration visual shows the above description.

Start Boring Height

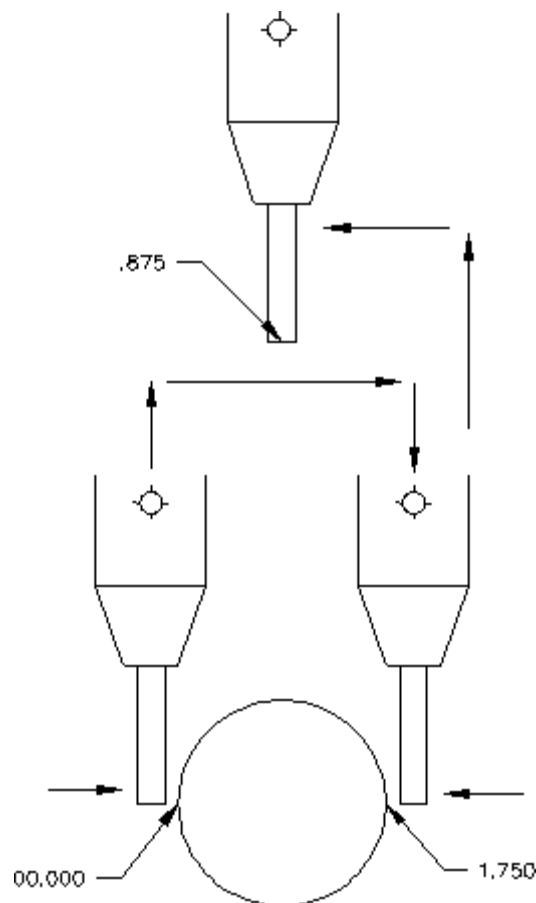

Pay attention when setting this height, there are often protrusions in the casting that will not allow the end mill to travel unobstructed all the way to the start of the lifter bore. It is safest to set the Start Boring Height above the Deck.

Lifter Bore Angle

Rottler has specific Lifter Bore spacers that are installed on the Cam bar to set the correct angle for lifter boring when using the Performance Fixture.

Lifter Bore 4th Axis

Lifter Bore programs are built the same as described in the Bore Mode 4th Axis. Only the differences will be discussed in this section.

Start Boring Height

Pay particular attention when setting this height, there are often protrusions in the casting that will not allow the End Mill to travel unobstructed all the way to the start of the lifter bore. It is safest to set the Start Boring Height above the Deck.

Lifter Bore Angle

The angle for each bank is located on the associated Locations page. Press the angle numerical value and a pop-up will open so you can type in the Lifter Bore angle.

Calculate Y-axis zero

This button is located next to the Y-axis locations for each Bank. You must first have the correct angle entered in the angle data box. Then press the calculate In/Out button. A window will open where you enter the center to center distance of the Cam to Crank bores. The In/Out locations will automatically be filled in.



Line Bore Mode

Create a Line Bore Operation in the mode select box from the main screen.

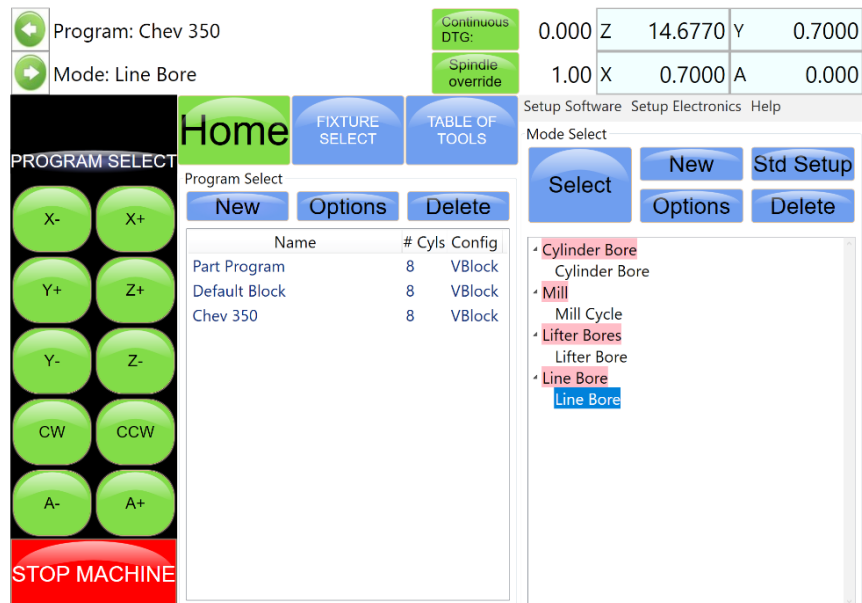

Mounting and Aligning the 90 Degree Head

Mount the 90-degree head onto the spindle and just snug mounting bolts. Use the following instructions to align the head. Mount a test indicator to the machine table or block. Align the indicator needle as shown in the figure below on the tool mounting surface.

Using the Y-axis handwheel increment move the indicator from one side to the other noting the amount of difference. Adjust the 90-degree drive until the variance across the face is less than $.0005''$. Tighten the mounting bolts for the head and check the surface again to be sure it did not shift when tightening the head.

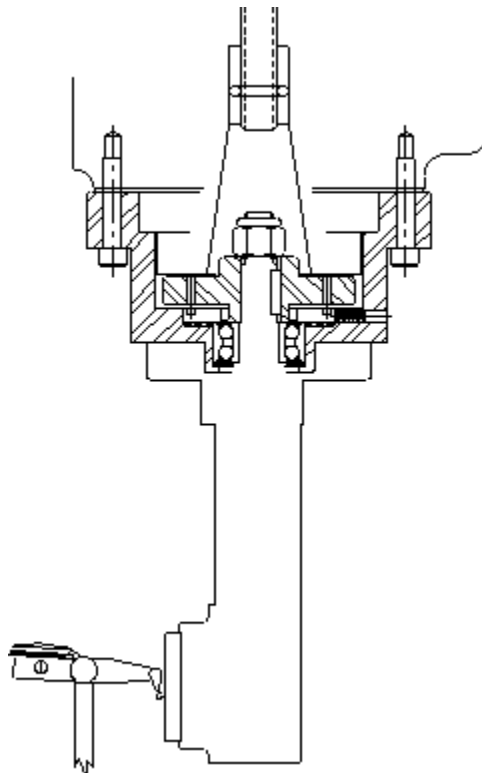

Setting Zeros

The purpose of setting zero points is to give the operator a specific point to build programs from. The machine also uses these zero points to run the program from. The zero points can be set at any point in the machines' travel. Each axis (except the Spindle rotation) will need to have a zero-point set for the machine to operate from.

X-axis (Horizontal Zero)

The Horizontal should be set about .050" offset from the front of the first main to be bored, making sure that, that position will allow the head to travel up without interference. Bring the head down and roughly center it in front of the first main. It does not need to be perfectly centered to set the horizontal zero. Double tap the X button from the set zeros tab to set the horizontal zero.

Y-axis (In/Out Zero)

Locate the supplied indicator and small magnetic base. Mount on cutterhead as shown below.

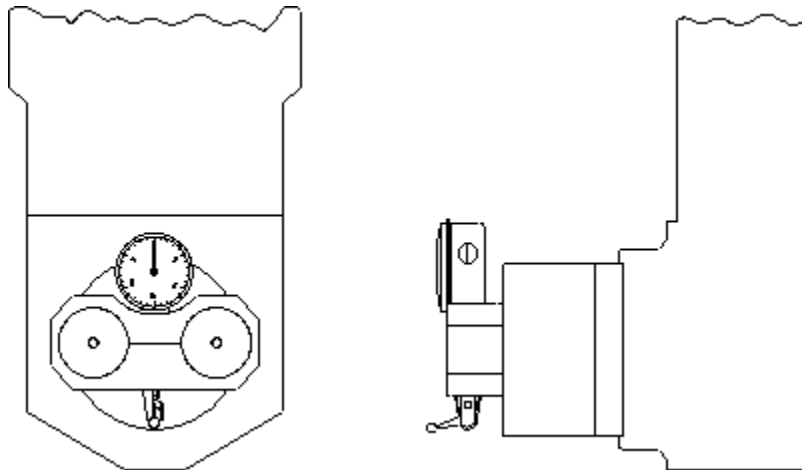

Using the X-axis handwheel increment option move the indicator inside the main bore, making sure the indicator is not touching the main bore at this point. You will be indicating both sides and the bottom of the saddle, generally the cap is not used while indicating the bore.

Physically move the indicator and mag base on the cutterhead until there is about .010" pressure on it. Start rotating the spindle CW and CCW watching the indicator. Move the machine in the Y-axis (In/Out) with the handwheel increment until the indicator readings are the same on both the sides and the saddle locations of the main. Once equal double tap the Y and Z buttons on the set zeros tab to set the zero locations for the program

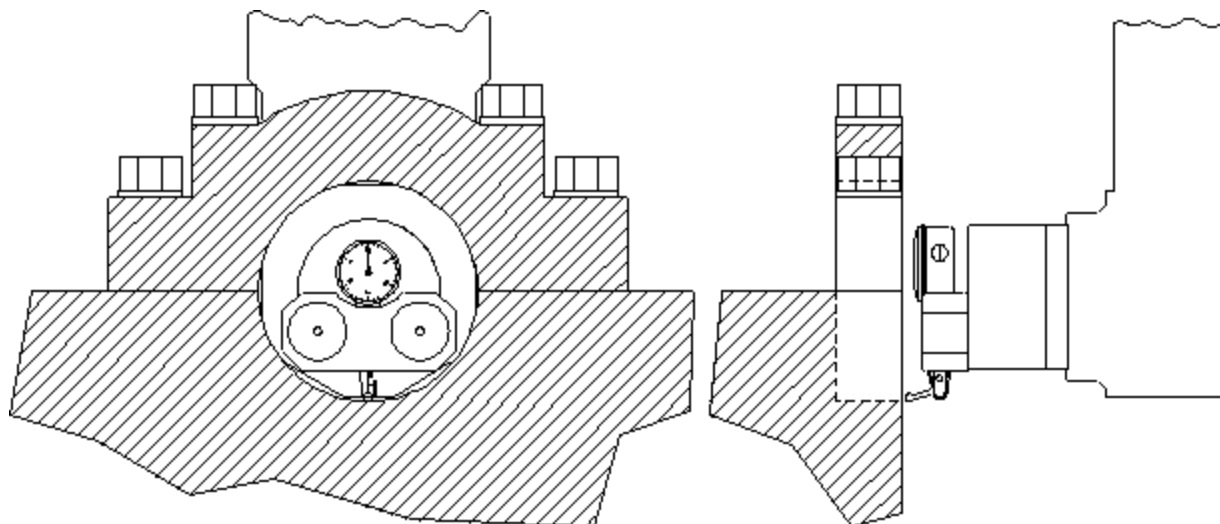

Programming Vertical Stops

There are two (2) vertical stops used in the Line bore mode. These are Bore Centerline and Block Clearance.

Bore Centerline

The first vertical stop is on the main bore centerline. This is the same as the vertical zero that is set when indicating the block main in the previous section

Block Clearance

The block clearance height is the height that the spindle will retract up to before moving to the next main bore location. This height should be set somewhere above the block where the 90-degree head will not interfere with the block during horizontal movements.

Programming Horizontal Stops

The Horizontal Zero was set .050" before the first Main Bore. The first Horizontal stop will be 00.000. Measure the distance between each main and enter it into the corresponding stop number.

Programming Bore Length

Measure the length of each Main Bore and enter that value into the corresponding length box.

Running the Auto Cycle

You will need to set a Feed Rate and Spindle RPM on this screen to run an auto cycle. After this is done press the "Move to Zeros" button. The spindle will move up the Vertical Block Clearance distance if it is not already there. It will then move to the Horizontal and In/Out axis to the zero position. The vertical will then move down to the zero position and stop.

CAUTION: If you press the MOVE buttons or the Cycle Start button the machine will not move the In/Out axis to the zero position. You need to move the In/Out axis to the zero position manually before you press Cycle Start the machine will go idle at this time. Pressing the "Start Auto Cycle" button will cause the entire cycle to run. After a program has been completed the machine will move the spindle over to the first Main Bore at the Clearance Distance.

Thrust Cutting

Refer to Line Bore in this section for mounting the block and aligning the 90-degree head.

Note: It is important to read through the entire Thrust Bearing Cutting section before entering any values or starting the Auto Cycle. You will better understand how the program operates and how the values effect the operation of the Auto Cycle.

The Thrust Cutting program can cut a single or double thrust face using circular interpolation.

Select the Thrust Bearing Cutting button from the Main Menu. This will bring up the Thrust Bearing Cutting Bore Mode with the Set Zeros tab shown.

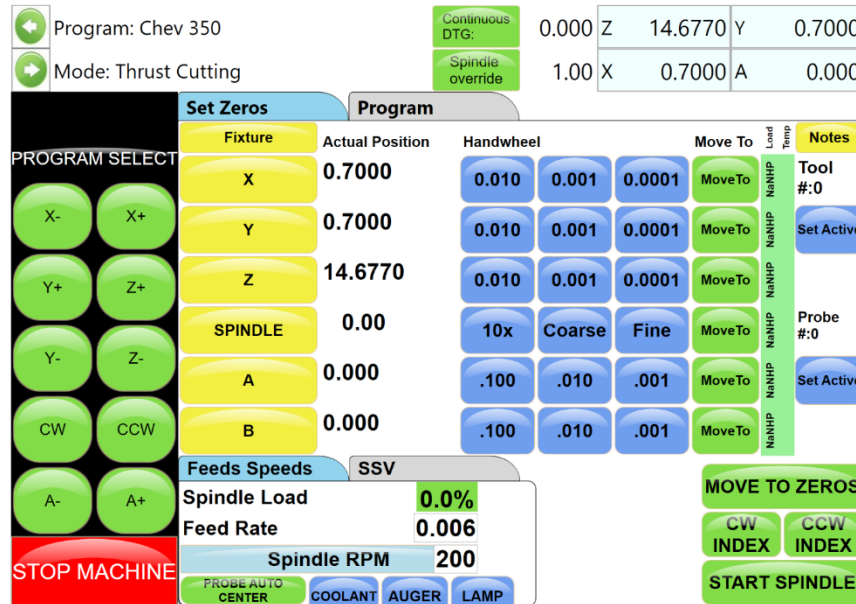

Setting Zeros

The purpose of setting zero points is to give the operator a specific point to build programs from. The machine also uses these zero points to run the program from. The zero points can be set at any point in the machines' travel. Each axis (except the Spindle rotation) will need to have a zero-point set for the machine to operate from.

X-Axis (Horizontal Zero)

The Horizontal should be set with the cutter to be used just touching the thrust face. Use the handwheel increment buttons to jog the cutter into this location and then double tap the X button to set the program zero.

Y-axis (In/Out Zero)

Locate the supplied indicator and small magnetic base. Mount on cutterhead as shown below.

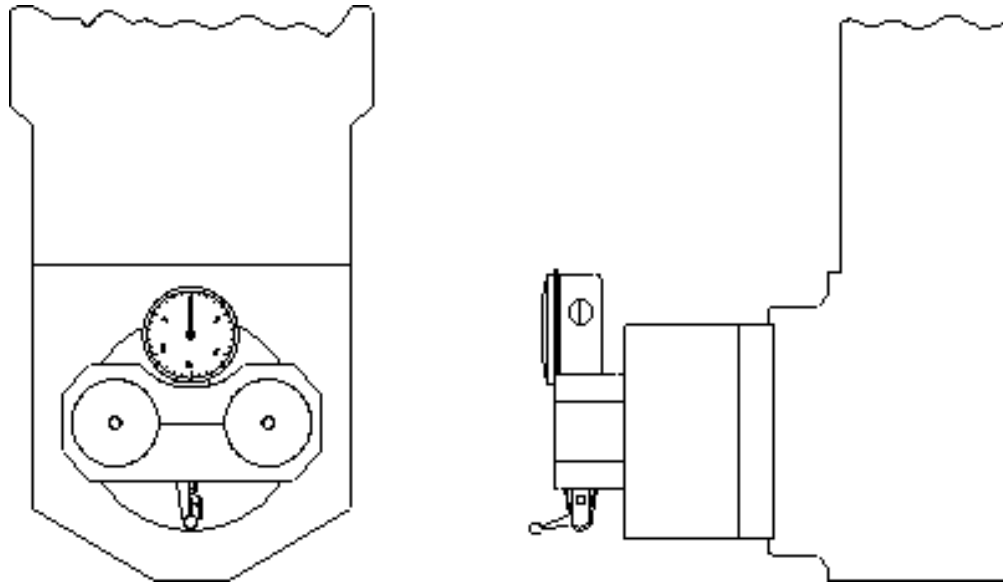

Using the X-axis handwheel increment option move the indicator inside the main bore, making sure the indicator is not touching the main bore at this point. You will be indicating both sides and the bottom of the saddle, generally the cap is not used while indicating the bore.

Physically move the indicator and mag base on the cutterhead until there is about .010" pressure on it. Start rotating the spindle CW and CCW watching the indicator. Move the machine in the Y-axis (In/Out) with the handwheel increment until the indicator readings are the same on both the sides and the saddle locations of the main. Once equal double tap the Y and Z buttons on the set zeros tab to set the zero locations for the program.

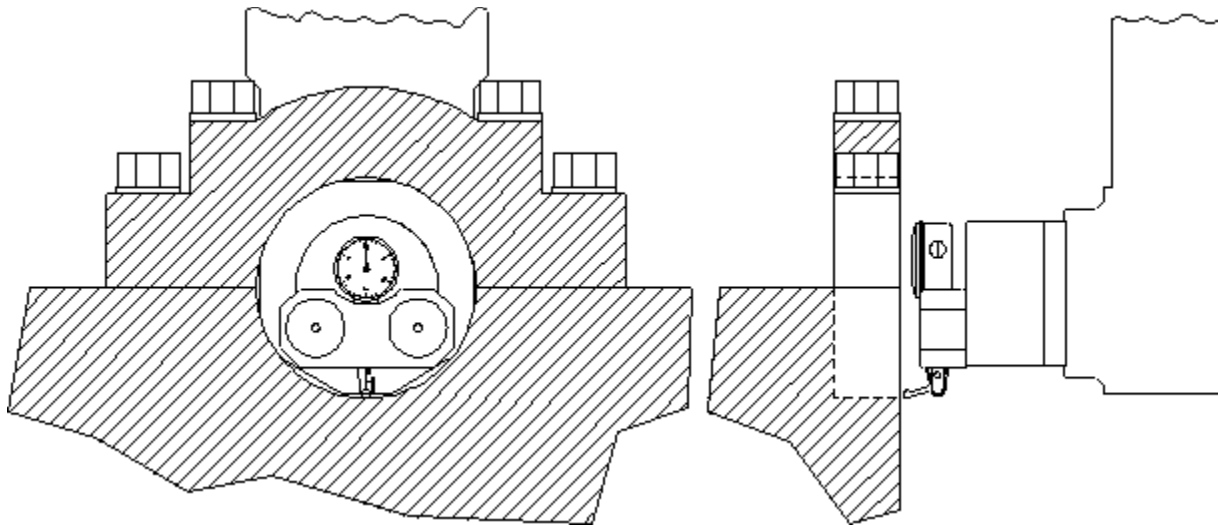

Dimensions & Auto Cycle

The program tab is where the critical dimensions are set for the thrust cutting process. Switch to this tab to enter the cutting dimensions and parameters.

The screenshot shows the CNC control interface with the following elements:

- Program:** Chev 350
- Mode:** Thrust Cutting
- Continuous DTG:** 0.000
- Spindle override:** 1.00
- Coordinates:** Z 14.6770, Y 0.7000, X 0.7000, A 0.000
- PROGRAM SELECT:** A grid of buttons for X-, X+, Y+, Z+, Y-, Z-, CW, CCW, A-, A+, and a red STOP MACHINE button.
- Set Zeros:** A tab for setting zero points.
- Program:** The active tab, containing:
 - Thrust Diameters:** Outside (3.0000), Inside (2.8000), Cutter (0.3750)
 - Clearances:** Z (5.0000 SET), X (0.1000 SET), Feed Through Rate (10.0000)
 - Dimensions:** Main Width (1.0000), Insert Width (0.2500), Left Depth of Cut (0.0010), Right Depth of Cut (0.0010)
 - Buttons:** CUT LEFT SIDE, CUT RIGHT SIDE, CUT BOTH SIDES

Thrust Dimensions

Outside

This is the outside diameter of the thrust face to be machined.

Inside

This is the Inside diameter of the thrust face to be machined.

Cutter

This is the diameter of the cutting tool to be used.

Clearances

Z (Vertical)

This is the distance, from zero, the 90-degree head will have to travel up to clear the main caps on the block.

X (Horizontal)

This is the distance, from zero, the 90-degree head will have to travel to clear the main for the next vertical move.

Bore Dimensions

Main Width

Width of the thrust face to be cut, this is the outside diameter minus the inside diameter.

Insert Width

This is the width of the cutting surface of the insert being used. This is used to calculate the step over required for interpolation.

Left Depth of Cut

This is the Inside diameter of the thrust face to be machined.

Right Depth of Cut

This is the diameter of the cutting tool to be used.

Cut Left Side

Cuts the left side thrust faces

Cut Right Side

Cuts the right side thrust faces

Cut Both Sides

Cuts both thrust faces.

Description and Running of the Auto Cycle

You will need to enter the Feed Rate and Spindle RPM the program will run at. There are no Move to buttons in this program. You **MUST** be at the zero positions when the Auto Cycle is started.

Start Auto Cycle

When you are at the corresponding zero positions press the Auto Cycle. The vertical feed will start at the programmed rate in an upward direction until the correct Outside diameter is reached. The circular interpolation will start at this point and go 360 degrees. It will then continue the circular interpolation back towards the center of the Main to clear the cutting tool from the thrust face. When the cutterhead is back at the center point (zero positions) of the Main, all motion will stop. The cutterhead will then rapid travel to the left taking the main width and the cutter diameter into account to reach the correct depth on the second thrust face. The same circular interpolation process will then be repeated for the second face. The cutterhead will then retract horizontally to the clearance distance then vertically to the block clearance distance.

When the program is running the “Start Auto Cycle” button will change to “Press to Pause”. If this button is pressed the machine will pause the program right where it is. At this point the screens are locked out from changing anything. The button will change to “Press to Resume”. If you want to resume press the button and the program will continue from that point on. If you do not wish to continue press the “Stop” button. This will put the machine back in idle mode and changes can be made to the program.

Cam End Tunnel Boring

To bore the end tunnels on a Block, refer to Block End Truing Fixture 650-3-30 when used with Cam Boring for setting up the block. Select a Cam bushing that will fit the existing Cam bore and place it in the Cam Spacer. Place the distributor end of the block facing up. You will need to be in the Bore Mode on the control panel. The Cam spacer placed in the center T-Slot should put the Cam tunnel in line with the Main bore.

Center the spindle over the Main bore using the electronic probe or magnetic base with indicator. Zero the X and Y axes.

Move the table the specified blue-print distance toward the Cam Tunnel. This distance should in the blue printing specifications for the block you are working with.

Check that you are on center of the cam bore with the electronic probe or indicator.

 **CAUTION** *Be very careful when correcting the existing Cam bore on the y-axis. This could cause the distributor gears to be damaged.*

Install the 650-2-3F cutterhead into the spindle.

Refer to the Bore Mode, programming Vertical Stops section earlier in this guide for guidance on setting up the vertical stops for this operation.

Note: It is important to bore the Cam End bores the full length of the cutterhead on both ends. If you do not you may have trouble getting the Cam Bar to bore the full length between Cam End Bores. Run the operation before proceeding.

Hint: It is helpful and more efficient to have three (3) tool holders set up for this procedure, two (2) of them for large material removal and one for a finish pass of .020” to .030”.

Note: To bore the oil groove in the Cam Bore, refer to the Cam Bore Oil Groove section in this chapter. This is a CNC operation.

Remove the block from the fixture, select a Cam bushing that will fit the bore that was made on the distributor end of the block.

Rotate the block so that the distributor end is now facing down. Tighten the block into the fixture. The Cam spacer will put the end bores in line.

Press the move to zeros button.

Repeat the above process on this end of the block to finish boring the Cam End Bores.

Cam Tunnel Boring

To bore the center of the Cam tunnel, refer to Cam Tunnel Boring in the Block Mounting section of this chapter. Mount the block as shown.

The following illustration shows the cutting tool and holder and how they are set inside the Cam Boring Bar.

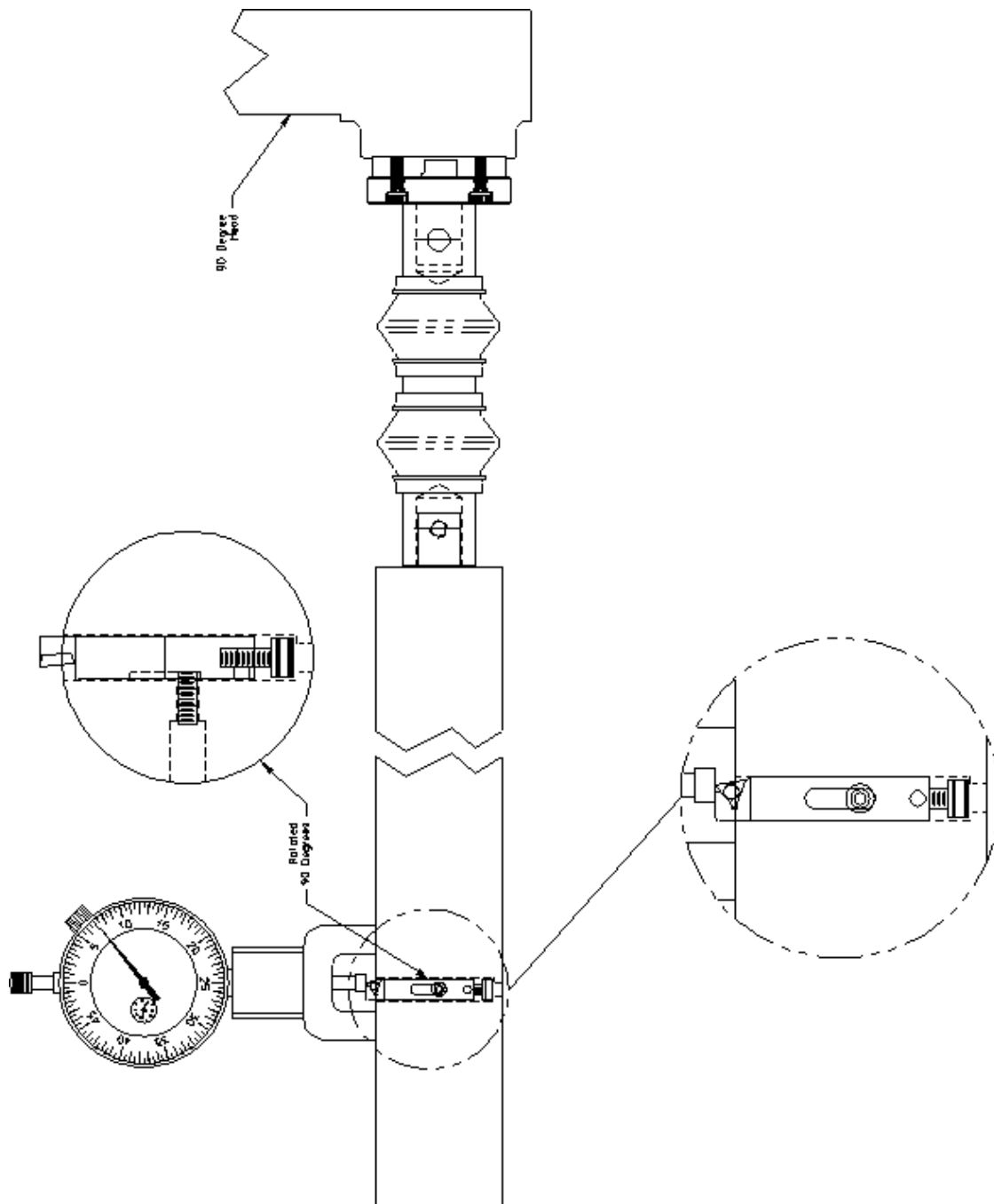

Zeroing the Micrometer

Remove the magnet keepers from the bottom of the indicators magnetic base. These should be put back on when the magnet is not in use to keep the magnet strong.

Place the magnet on the smooth portion of the bar next to the tool holder hole. Set the zero on the indicators dial, noting the number of revolutions the dial has made.

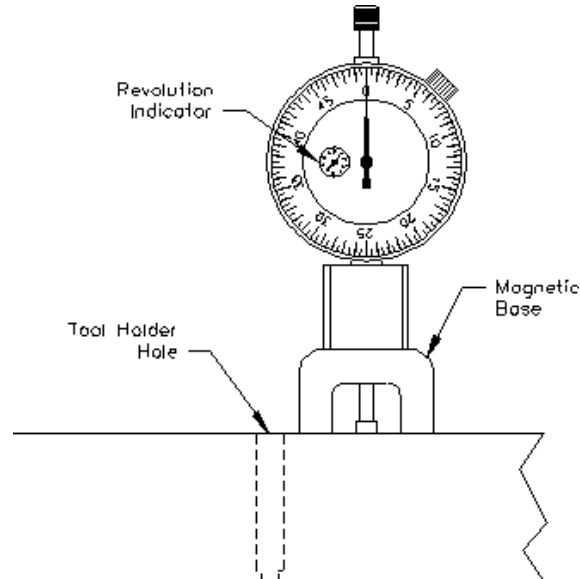

Setting Cutting Size

The diameter of the Cam Bar 650-2-32D is 1.7500". The 8-32 X 1/2" socket head cap screw on the back of tool holder is used to adjust size. When the tool holder is inserted into the Cam Bar the cap screw goes against a ledge inside the Cam Bar. When the cap screw is turned in the size will get smaller. When the cap screw is turned out the size will get bigger.

CAUTION *When adjusting the size on the tool holder, you must remember that the amount that will be taken off the diameter will be twice the reading on the dial indicator.*

When the dial indicator reads zero the bar will cut 1.7500". Double the amount past zero on the dial indicator and add that to 1.7500" to determine the cut diameter.

Once the size has been set, lock the set screw in the Cam Bar to secure the tool.

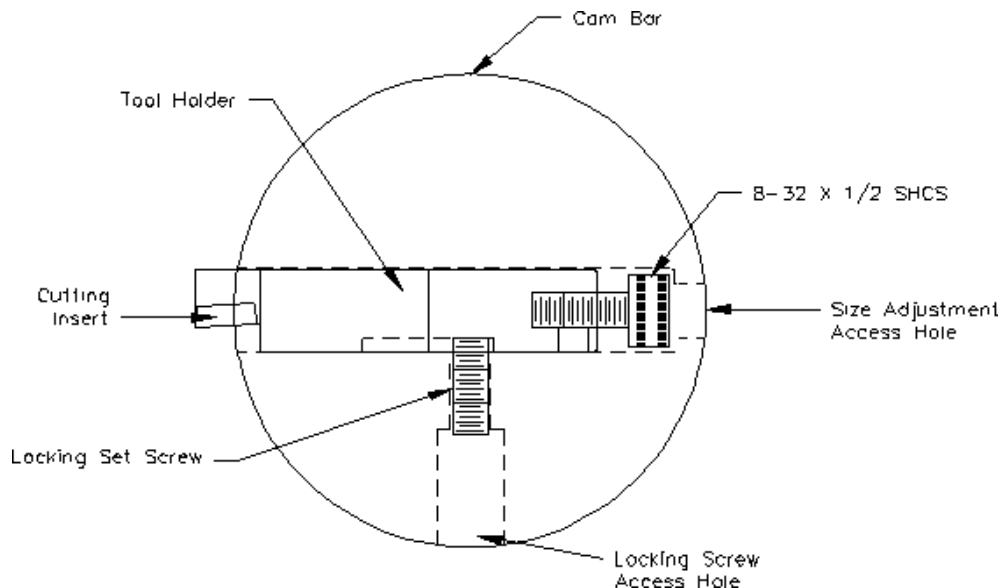

Refer to the Line boring section of this chapter for mounting and alignment of the 90-degree head.

Select Line Bore Mode of operation.

Mount the dual flex coupling to the 90-degree head with the two (2) supplied socket head cap screws. Install one Cam Bearing Locator into the left side of the block.

Slide the Cam Bar into the Cam Tunnel and then into the right-side locator. Keep the end of the Cam Bar with the adapter on it to the right.

Slide the second locator onto the Cam Bar, then the locator into the Cam Bore. The cutting tool needs to be between the two (2) locators.

Bring the 90-degree head down and line up the end of the dual flex coupling with the adapter on the Cam Bar. This does not have to be a precise line up, the dual flex coupling will take care of any alignment variance. Tighten the socket head cap screw on the dual flex coupling on to the adapter on the Cam Bar.

Press the Vertical, Horizontal, and In/Out zero buttons.

Final set up should look like the drawing on the following page. The mounting components are not shown on this drawing. Refer to the block mounting section of this chapter.

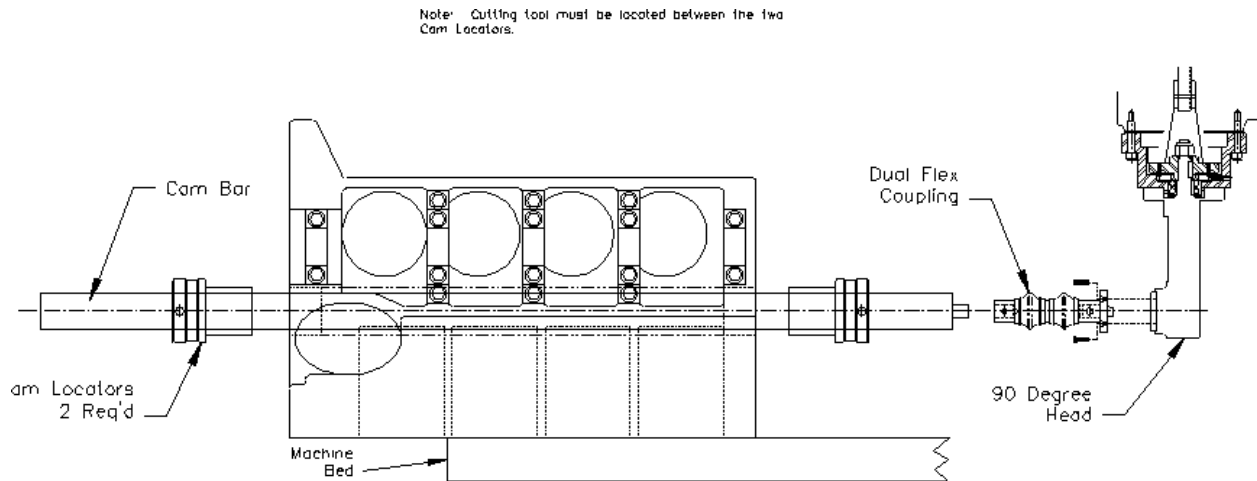

Setting Vertical Stops

Make sure the machine is at the zero positions as described previously.

When using the Line Bore Mode to do the Cam Tunnel boring the vertical stops described here will never change. They must be used to run the cycle without damaging parts.

Block Clearance: -.001

Block Center Line: 00.000

Setting Horizontal Stops

All of the Horizontal stops are to remain at 00.000 when using the Line Bore Mode to do Cam Tunnel boring. The only setting that gets changed on this screen is the Bore Length for Horizontal stop 1. This will be the distance between the two (2) end Cam bores that needs to be bored out.

Auto Cycle

You **DO NOT USE** the Auto Cycle when Cam Tunnel boring. The only items that get used on this screen are the Feed Rate and Spindle RPM.

Recommended feeds and speeds will be discussed later in this chapter.

Manual Bore

This screen is used to bore the Cam Tunnel. With the Horizontal and the In/Out axis at the zero position and the Vertical at or above the Block Clearance Height, Press the BORE1 button.

The spindle will do a rapid move down to the Block Center Line position (this is only .001 so will not notice the move). The spindle and Horizontal feed will start at the programmed speed. The machine will continue boring horizontally until the horizontal position set in the Bore Length is reached. The Vertical will retract .001 and the horizontal will retract back to the zero position.

Recommended Boring Procedure

The three (3) tool holders included in this package should be used as dedicated holders. Two of them set for roughing passes and the third set for a final finish pass.

It is recommended to set the first two tool holders for a .100" pass each, then set the third tool for the finish size.

Size is not critical on the first two passes, these tools can be set and not adjusted for each use. The third tool should be checked with the dial indicator for final size each time you use it.

Recommended Feed Rate: .001 - .003

Recommended Spindle RPM: 300 – 500

IMPORTANT: You should put a light coating of light weight oil on the Cam Bar to prevent it from seizing up as it goes through the Cam Locators. At higher spindle speeds the bar heats up more.

Connecting Rod Boring

Main Screen

Select the Connecting Rod operation from within the mode select tab. This will add the operation and you may then open the connecting rod operation to bring up the standard set zeros page.

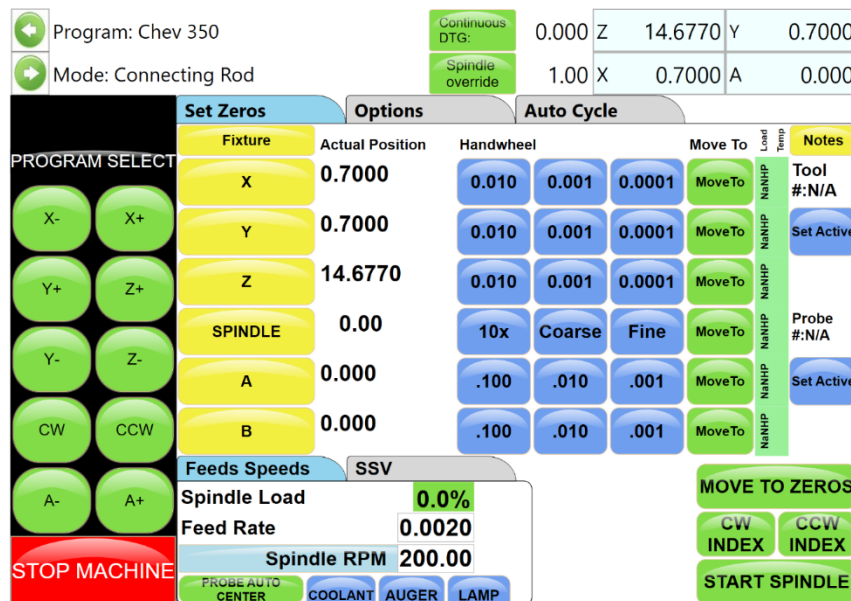

Setting Zeros

Using a dial indicator or the touch probe, find the center of the connecting rod large bore, typically this is done only on the connecting rod body side and not the cap side. Double tap the X and Y buttons to set the program zeros once the center is found.

Setting Vertical Zero

Using the electronic probe with the depth probing routine or the tool to be used. Touch off the top surface of the large bore on the connecting rod. Double tap the Z button to set the program vertical zero.

Program Options

This screen is used to input all the parameters for boring both the big and small end of the rod plus setting positions for centering and measuring.

Program: Chev 350	Continuous DTG: 0.000	Z	14.6770	Y	0.7000
Mode: Connecting Rod	Spindle override: 1.00	X	0.7000	A	0.000

	Set Zeros	Options	Auto Cycle
PROGRAM SELECT X- X+ Y+ Z+ Y- Z- CW CCW A- A+ STOP MACHINE	Left Bore		Right Bore
	Vert Clearance	0.0000 SET	Vert Clearance 0.0000 SET
	Vert Centering	0.0000 SET	Vert Centering 0.0000 SET
	Vert Probe Height	0.0000 SET	Vert Probe Height 0.0000 SET
	Vert Start Bore	0.0000 SET	Vert Start Bore 0.0000 SET
	Bore Depth	0.0000 SET	Bore Depth 0.0000 SET
	Feed	0.0020	Feed 0.0020
	RPM	200.00	RPM 200.00
	Tool #:	N/A Set Active	Tool #: N/A Set Active

Vert Clearance: This is the vertical height of the cutterhead with reference to vertical zero to where the cutterhead will move before any horizontal movements take place.

Vert Centering: This is the vertical height of the cutterhead with reference to vertical zero to where the cutterhead will move to allow the operator to center the machine with a dial indicator.

Vert Probe Height: This is the vertical height that the machine will move to before probing the bore to re-center the machine using the three-point probe routine.

Vert Start Bore: This is the vertical height of the cutterhead with reference to vertical zero to where the cutterhead will move to start boring the conrod. This is set about .040" (1mm) above the side of the connecting rod bore

Bore Depth: This is the vertical height of the cutterhead with reference to vertical zero to where the cutterhead will stop boring, index the boring tool and retract back to the clearance position after it's finished cutting.

Tool #: Click the Tool word to bring up the tool select form and define the tool to be used for the individual bores.

Auto Cycle

This screen is used to the connecting rod program. From the Auto Cycle tab the operator can use the Blueprint, Indicated or Probed tabs to machine using the respective methods as described in the 3 Axis Block Boring section.

Program: Chev 350	Continuous DTG: 0.000	Z	14.6770	Y	0.7000
Mode: Connecting Rod	Spindle override: 1.00	X	0.7000	A	0.000

PROGRAM SELECT	Set Zeros	Options	Auto Cycle	
	Blue Print	Indicated	Probed	
X- X+ Y+ Z+ Y- Z- CW CCW A- A+ STOP MACHINE	Left Bore		Right Bore	
	X Center	0.0000	X Center	0.0000
	Y Center	0.0000	Y Center	0.0000
	Centers			
	Center to Center Distance		0.0000	
	Center to Center Angle		0.00	
	COPY VALUE	BORE LEFT	COPY VALUE	BORE RIGHT
	BORE BOTH SIDES			

Bore Both: If special cutterheads with big and small end tooling in one are being used, the block can be checked so that the machine will bore both big and small end in one cycle. Normally the big and small ends are bored with different cutterheads and this block will be unchecked.

Note: Do not stop an automatic cycle in mid cycle and then try to start it again. The CNC code running behind the Rottler screens use offsets in the controller. If the machine is stopped during an automatic cycle the machine must be shut down and restarted to clear the offsets. Otherwise the displayed position and actual position of the machine will not be correct.

Fixture Control Panel

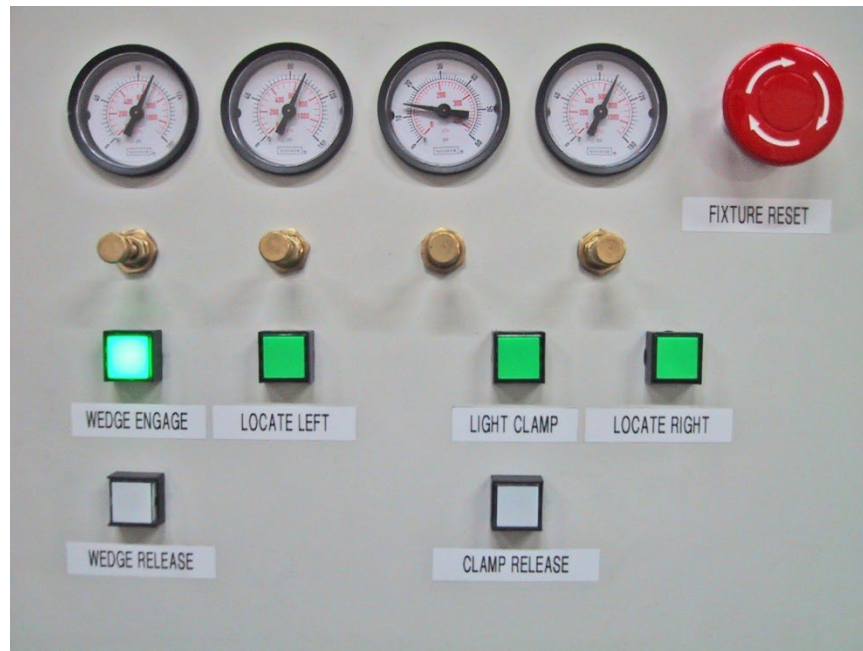

Set Up Procedure For Conrod Fixture

Select the widest big and small end ball locators that will fit inside the conrod big and small end bores.

Press Locate Right and the right-hand ball locator will move up and stop against its end stop, then remove the air pressure supply to the conrod fixture so that the ball locator pivot arms may be moved manually.

Fit the selected ball locators to the right- and left-hand mounting positions. Be sure there are no chips and that the locators fit exactly in their mounting positions. Connect the air pressure to the fixture.

Press Locate Right Button, the right-hand ball locator will move up and stop against its end stop. Select the correct conrod support and place across the conrod fixture.

Place the conrod to be bored into the fixture so that the big end bore touches both the balls of the right-hand ball locators.

Adjust the conrod rest so that the rod lies approximately horizontal.

Adjust the 3 big end support pads so that each support pad locates on the side of the big end and does not protrude into the big end bore. This will require removing and refitting the conrod to be sure the 3 support pads are correctly located and their hold down cap screws are tight.

Readjust the conrod support to allow the conrod to lie horizontal with no rock or tilt of the conrod on the 3 big end support pads.

Remove the conrod from the fixture.

Press locate left and the left-hand small end ball locating device will lift up.

When the left-hand ball locating device is at its end of travel, place the conrod back in the fixture and adjust the left-hand slide assembly so that both the left-hand locating balls contact the bore inside the conrod small end.

Remove the conrod from the fixture.

Slide the left-hand locating assembly approximately 1/2" (12.7mm) to the right and lock both hold down handles securely, this will ensure that the small end ball locators contact the small end with some preload. Place the conrod in the fixture.

Position the clamp arms so that their feet are approximately 1/8" (3mm) above the side of the big end, be sure that they do not protrude into the big end bore to be machined and adjust their travel limit stops and lock the lock nuts.

Press the Light Clamp button, this will place light clamping pressure on the clamp arms and lightly hold the conrod down against the 3 support pads under the big end of the conrod.

Press the Locate Left button, the small end ball locator will move up and contact the bore of the small end of the conrod and firmly press it against the big end and straighten the conrod along the center of the fixture.

Select a set of wedges that will allow the outside of the small end of the conrod to be supported during boring so that there is no chatter or vibration during boring.

Press Wedge Engage button, the wedges will be pressed against the outside of the small end.

The conrod is now ready to be bored.

Air Pressure Settings

- | | | |
|--------------------------------|--------------|-----------------|
| • Right Hand Side Air Gage: | Locate Right | 100psi (6.5Bar) |
| • Second from Right Hand Side: | Light Clamp | 15psi (1.0Bar) |
| • Second from Left Hand Side: | Locate Left | 30psi (2.0Bar) |
| • Left Hand Side Air Gage: | Wedge Engage | 30psi (2.0Bar) |

Backing Up and Restoring Block Profiles

Backing Up Profiles

This section will explain how to back up and restore the operator created block profiles for DM controlled machines for archival purposes or to transfer to a different machine.

First step is to open your file browser and locate the RottlerWPF file on the C disk drive.

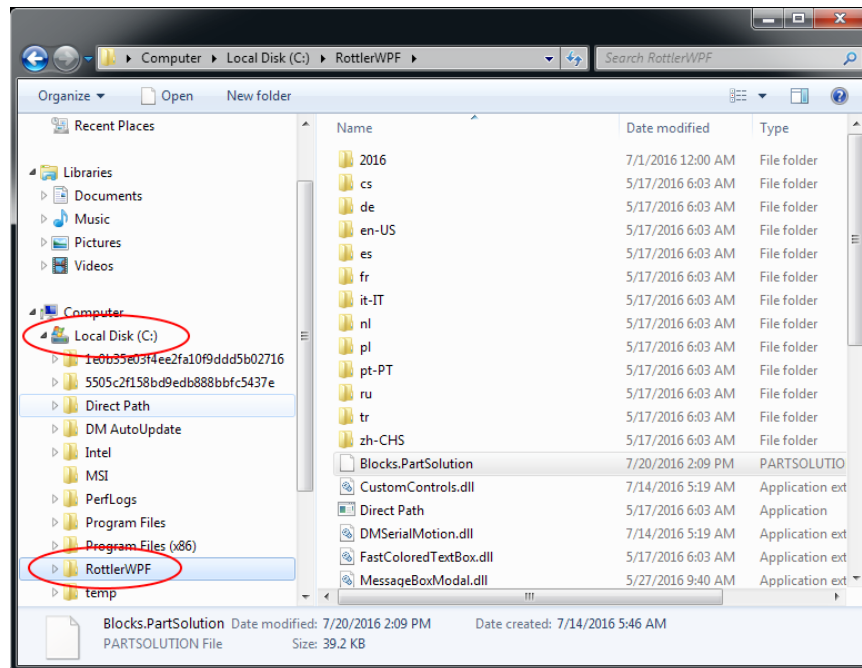

The next step is to plug in a flash drive to an open USB port.



The following pop up box will appear on your screen.

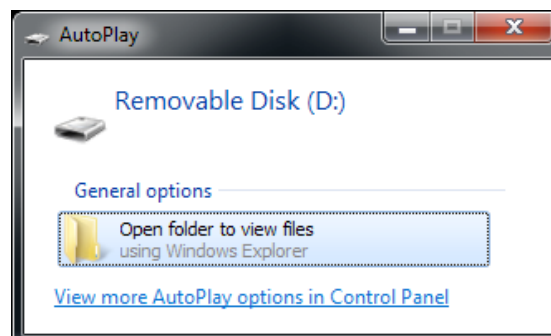

Click on the “Open folder to view files” option and the following screen will appear. This is the contents of the flash drive you just plugged in.

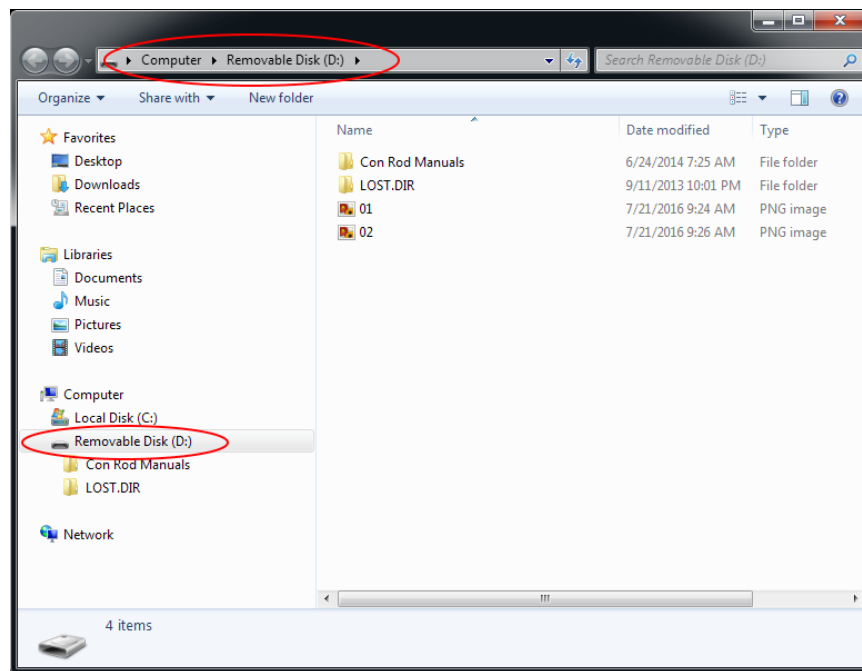

Next resize and arrange both file browsers so that they are side by side.

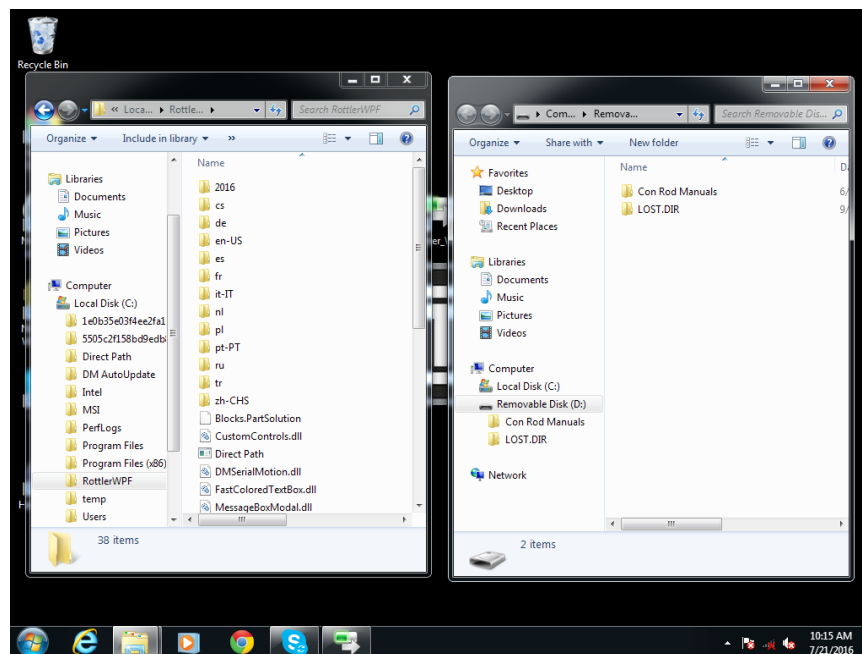

Block profiles are backed up each time the machine is run with the current profiles being shown in the RottlerWPF folder. All that needs to be done to back up the current profile is to simply drag it from the RottlerWPF folder to the flash drive folder. A copy of the file will be placed on the flash drive.

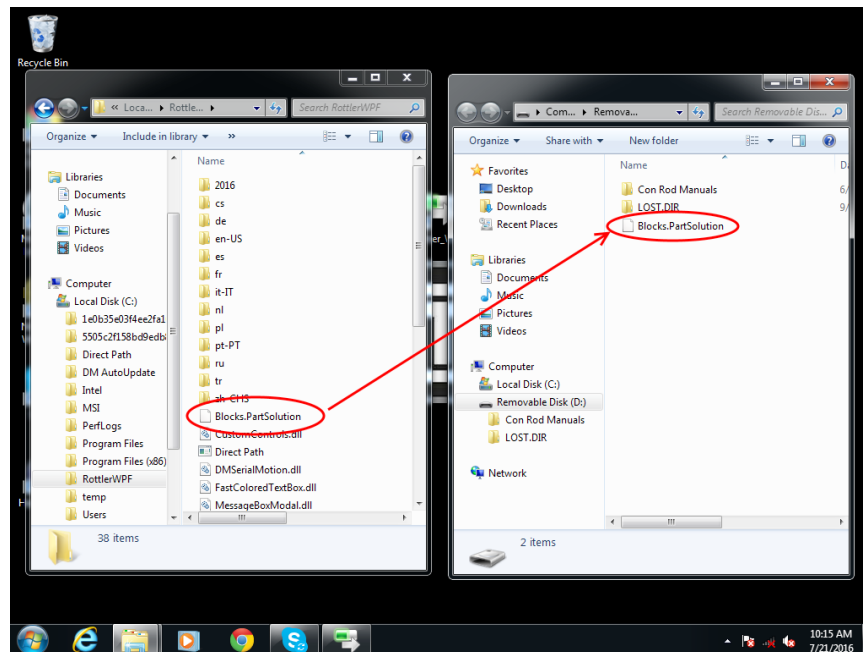

Backup is now complete. Close both file browser windows and remove the flash drive.

Restoring Block Profiles

To restore or add block profiles go through the first 5 steps explained previously.

Highlight the block profiles file in the flash drive and drag it into the RottlerWPF folder on the local hard drive.

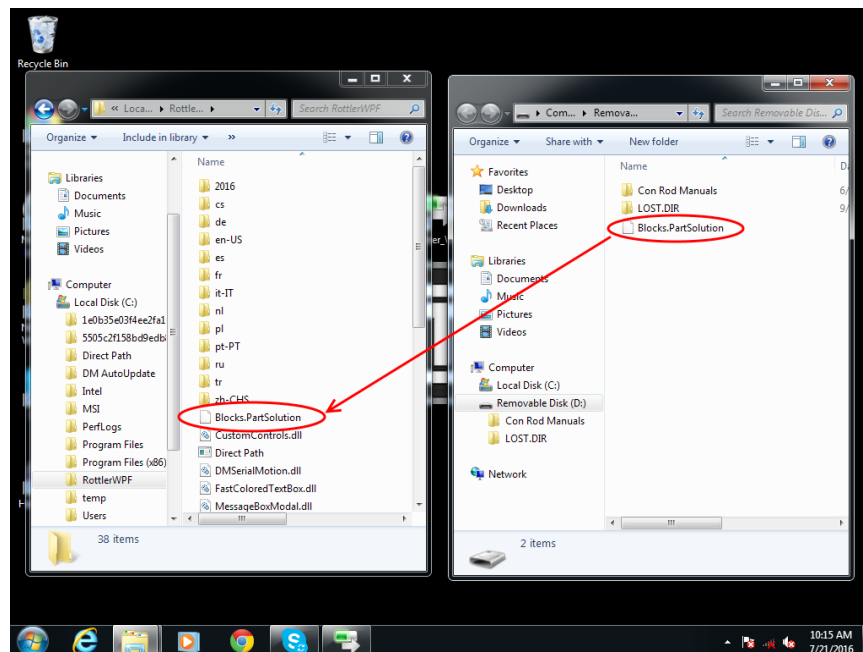

You will get a pop-up window about there being a file of the same name in the destination folder. Click on the Copy and Replace option.

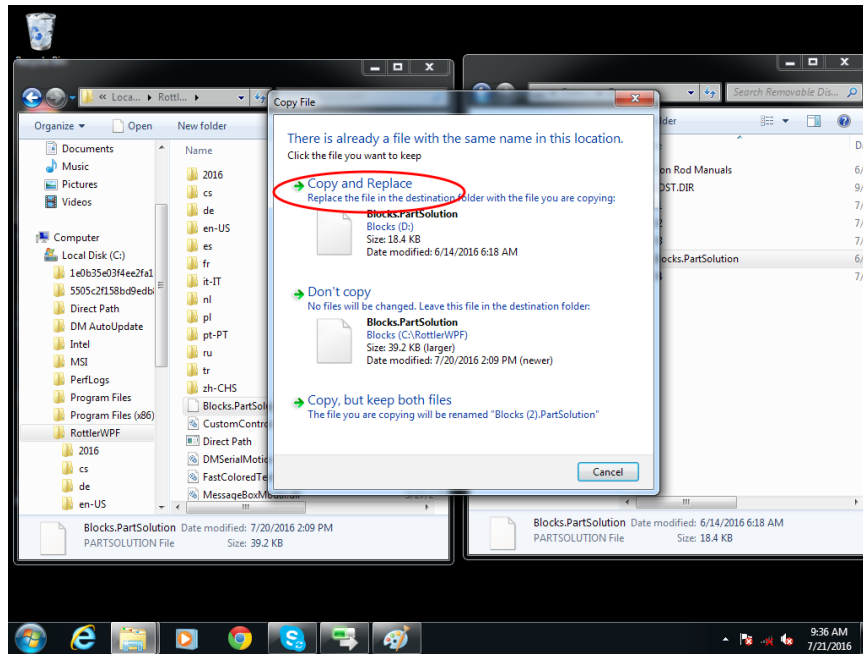

The archived block profiles will now be installed.

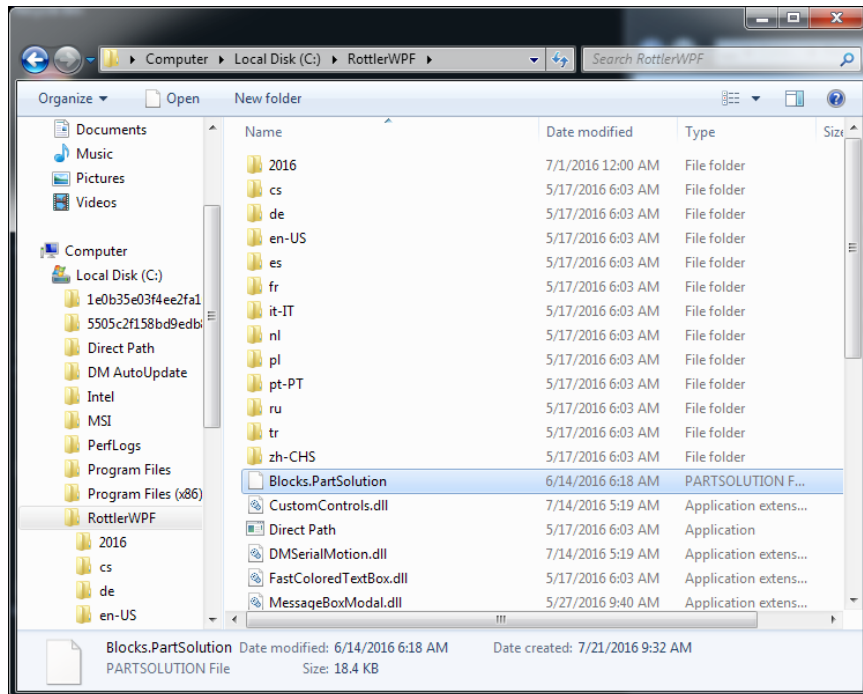

Close both browser windows and remove the flash drive. The restore process is now complete.