

ROTTLER

EM103/4/5H SERIES CNC MACHINING CENTER MAINTENANCE AND PARTS MANUAL

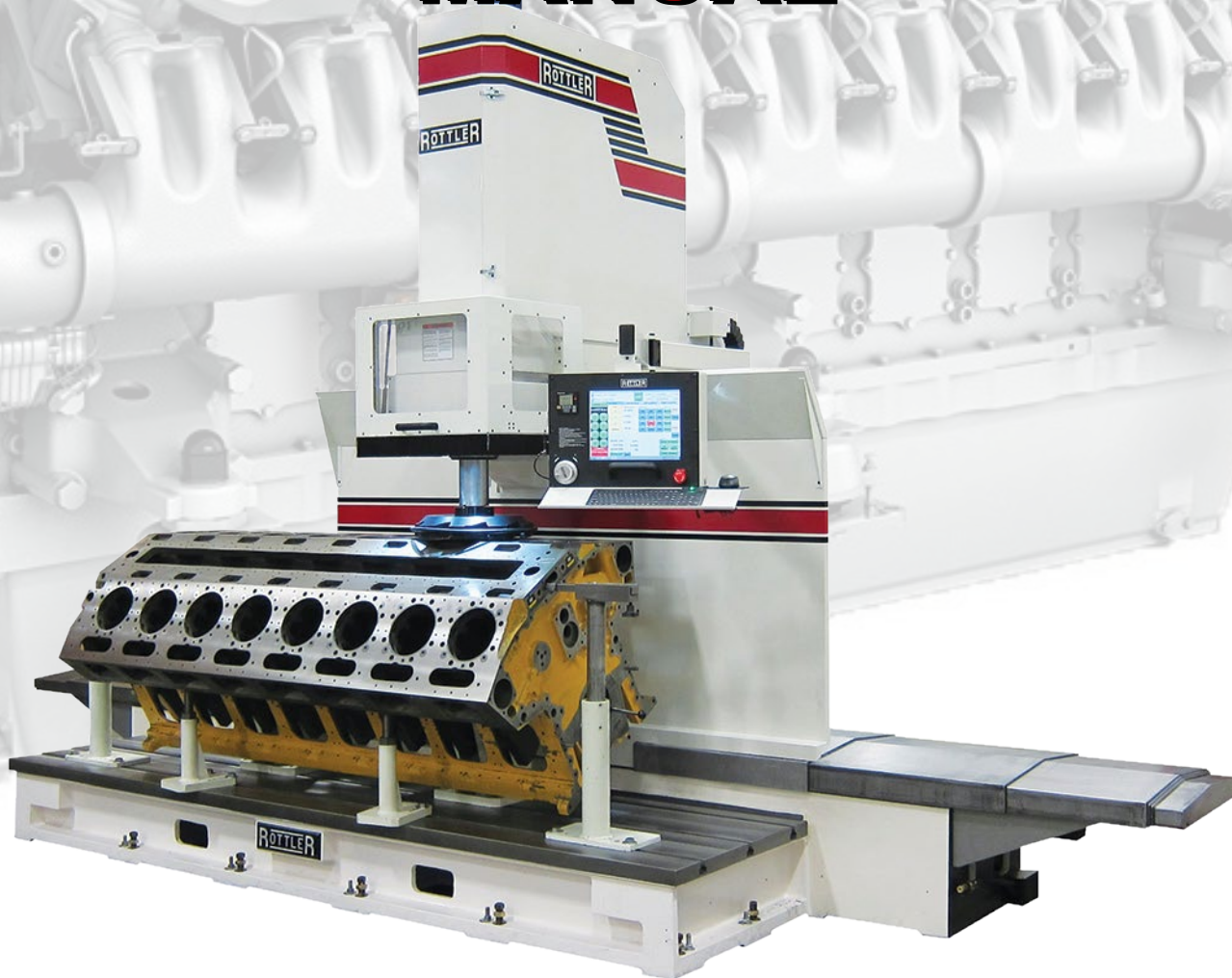

PARTS ORDERING

For optional equipment catalogs, please visit <https://www.rottlermfg.com/documentation.php>

For fastest service ordering parts or equipment, contact us via e-mail with the information below. For customers within the U.S., send emails to parts@rottlermfg.com, for customers outside of the U.S., use intlparts@rottlermfg.com

Have the following information on hand to expedite the ordering process:

1. Your name, business name, and contact number
2. Customer number, or your billing address if you do not have a customer number
3. Shipping address if different from the billing address
4. Machine model and serial number
5. Part number and description of the item(s) to order
6. Preferred method of shipment

For customers outside of the U.S. requiring faster service, contact your local distributor.

In some cases, you may be requested to send a photo of the part you are ordering if it is a replacement part or does not appear in our database.

If you are unsure which part you need to order, contact our service department, and ask to speak to one of our service consultants. They will assist you in determining which part(s) you require.

THERE IS A MINIMUM ORDER OF \$25.00

MANUAL SECTIONS

INTRODUCTION

MAINTENANCE

TROUBLESHOOTING

MACHINE PARTS

SDS

INTRODUCTION

Contents

Introduction	1-1
Description	1-2
Disclaimer	1-2
Limited Warranty	1-3
Online Documentation Access	1-4

Introduction

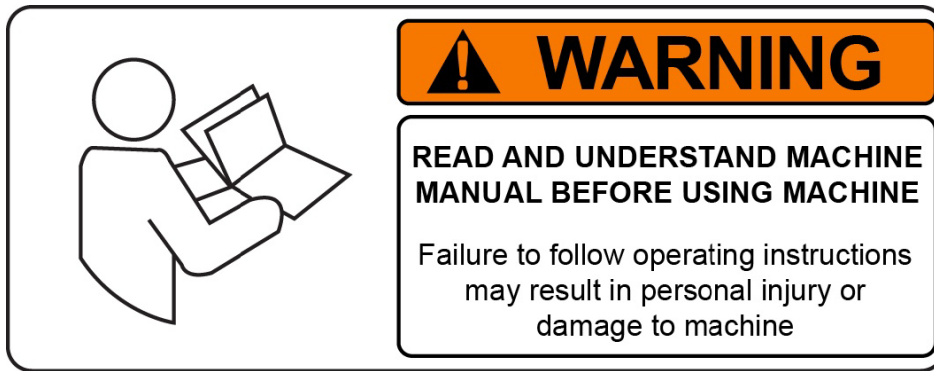

READ THE SAFETY SECTION OF THE OPERATIONS MANUAL BEFORE INSTALLING THE MACHINE. THOROUGHLY UNDERSTAND ALL SAFETY ISSUES BEFORE OPERATING MACHINE.

ATTENTION OWNER/BUSINESS MANAGER

To validate the warranty on your new Rottler machine, please be sure to sign and complete the “Installation Report” located in this manual.

We suggest that the new user(s) of the EM103/4/5H read the “Control Definitions” section of the Operations Manual to understand how the machine operates.

The “Operating Instructions” section of the Operations Manual should be read in order to familiarize the user with the actual button pushing sequences required to carry out a job. These sections in the manual should be considered an introduction. As the operator(s) of the EM103/4/5H series machine gain experience with using the different functions of the machine, complicated setups and programs will make more sense.

The Maintenance and Parts Manual contains information on part number references and routine machine maintenance. The operator(s) should read and become familiar with these areas as well.

Description

The model EM103/4/5H machine is a precision, single point boring, and high-speed surfacing unit. It can be equipped with tooling and accessories for surfacing and re-boring most medium to large gas and diesel engine blocks, both in-line and V-type.

EM103/4/5H machines can be easily tooled to machine a wide range of engines, including European and Asian engines. It can also be easily adapted to perform other boring and surfacing operations.

The machine is designed to maintain alignment of cylinder bores, cylinder heads, and deck surfaces to the pan rails and main bearing bore locations, as was done in the original factory machining. This overcomes the many inaccuracies and out-of-alignment problems associated with clamping portable boring bars to the cylinder head surface of blocks.

Convenient controls, fast block clamping, and precise 3-axis CNC positioning means considerable savings in floor-to-floor time and operator involvement.

Change over or resetting time required to set up V-type or In-line engines is minimized, making this machine highly suited to shops where engines cannot be run through in model lots.

All feeds and rapid travels are power operated and controlled from the control panel.

Disclaimer

The EM103/4/5H Manual (henceforth to be referred to as the "Manual") is proprietary to Rottler Manufacturing LLC. ("Rottler Manufacturing") and no ownership rights are hereby transferred. No part of the Manual shall be used, reproduced, translated, converted, adapted, stored in a retrieval system, communicated or transmitted by any means, for any commercial purpose, including without limitation, sale, resale, license, rental or lease, without the prior express written consent of Rottler Manufacturing.

Rottler Manufacturing does not make any representations, warranties or guarantees, express or implied, as to the accuracy or completeness of the Manual. Users must be aware that updates and amendments will be made from time to time to the Manual. It is the user's responsibility to determine whether there have been any such updates or amendments. Neither Rottler Manufacturing nor any of its directors, officers, employees, or agents shall not be liable in any manner whatsoever to any person for any loss, damage, injury, liability, cost, or expense of any nature, including without limitation incidental, special, direct or consequential damages arising out of or in connection with the use of the Manual.

Rottler Manufacturing and its employees or representatives are not responsible for any information regarding final specifications of any workpiece that is created as a final product when using Rottler equipment. It is the responsibility of the end user of Rottler equipment to determine the final dimensions and finishes of the workpiece that they are working on. Any information regarding final dimensions and finishes that appears in any Rottler literature or that is expressed by anyone representing Rottler is to be regarded as general information to help with the demonstration of or for operator training of Rottler equipment.

Limited Warranty

Rottler Manufacturing Company Model EM103/4/5H parts and equipment is warranted as to materials and workmanship. This limited warranty remains in effect for one year from the date of installation or two years from the date of the original shipment from Rottler or whichever date occurs first. This only applies if the machine is owned and operated by the original purchaser and is operated and maintained as per the instructions in the manual. A machine is warranted only if the Installation Report has been properly executed by a certified installation person and received by Rottler at the time of actual installation.

The products are warranted upon delivery to conform to their published specifications and to be free from defects in material and workmanship under normal use for a period of one year from shipment. Should a product not be as warranted, Rottler sole obligation shall be, at its option, to repair, correct or replace the product or to refund the amounts paid for the Product upon its return to a location designated by Rottler. No warranty shall extend to rapid wear Products (including tooling) or to Products which have been subject to misuse (including any use contrary to Rottler instructions), neglect, accident (including during shipment), improper handling or installation, or subject to any modification, repair or service not certified by Rottler. Rottler shall not be liable for any consequential, direct or indirect damages or for any other injury or loss. Buyer waives any right, beyond the foregoing warranty, to make a claim against Rottler. No warranty is provided for any Products not paid in full.

Merchandise cannot be returned to Rottler without prior approval. Customer must contact the Parts Department to get approval and to be issued a Return Goods Authorization number (**RGR#**). Merchandise authorized for return must be returned prepaid. If merchandise is returned with shipping charges collect, the actual amount of these charges may be deducted from any credit which may be due the customer. The **RGR #** assigned by the Parts Department should be written on the shipping label and must appear on a copy of the invoice(s) covering the original shipment. This invoice copy must be included in the box with the parts. Shipment must contain **ONLY** those items on the **RGR** as approved for return. Merchandise must be received within 10 days of the date of **RGR** or the **RGR** will be canceled. All returned merchandise may be subject to a 20% restocking fee on under \$1,000.00 amount or 10% on any items over \$1,000.00. Parts or tooling over 30 days old are considered as customer property and can only be returned with prior approval from Rottler Corporation Management.

The issuance of an **RGR DOES NOT** guarantee credit - it is only authorization for the return of the goods. Credit for return merchandise is at the sole discretion of Rottler. Credit will be issued only after inspection of returned goods.

Tools proven to be defective within the warranty period will be repaired or replaced at the factory's option.

We accept no responsibility for defects caused by external damage, wear, abuse, or misuse, nor do we accept any obligation to provide compensation for direct or indirect costs in connection with cases covered by the warranty.

Online Documentation Access

Online documentation for machines and optional equipment, including manuals and catalogs, can be accessed at the Rottler website. To access documentation, open your browser and navigate to <https://www.rottlermfg.com>

Scroll to the bottom of the page and under the “Owner Resources” title, click the type of documentation you want to access.

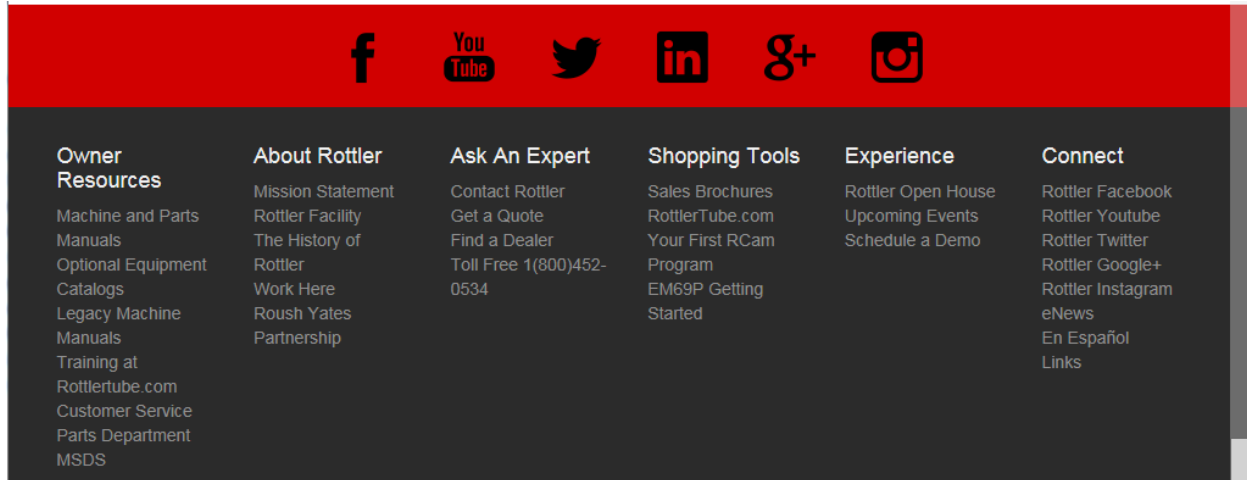

If a log-in window pops up asking for a user name and password, fill in the blanks as shown:

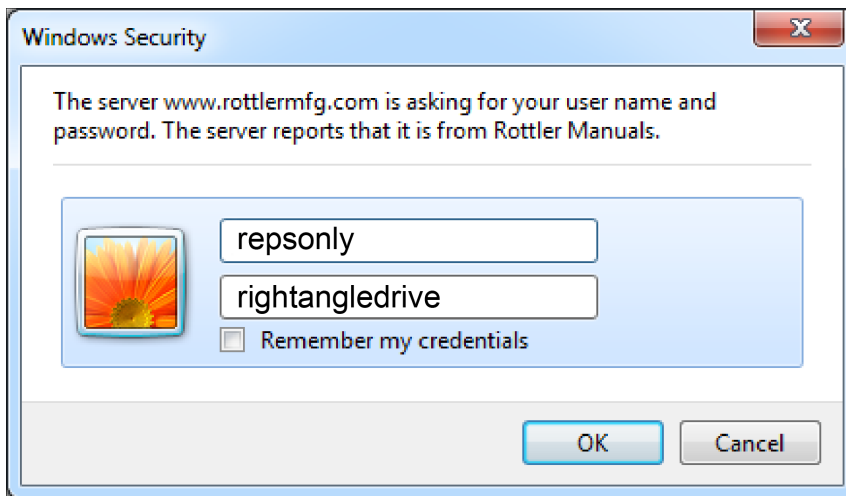

MAINTENANCE

Contents

Quick Reference Lubrication Chart	2-3
Quick Reference Preventative Maintenance Chart.....	2-3
Maintenance	2-4
Lubrication.....	2-4
Outer Spindle	2-4
Oil Reservoir System	2-5
Inner Spindle Bearings.....	2-5
Z-Axis Ballscrew Bearings	2-5
X-Axis Linear Bearings	2-5
Priming Spindle Base Oil Lines.....	2-6
Lubrication Locations	2-7
Right Angle Drive Lubrication	2-9
Tool Changer Setup	2-10
Magnescale Indicator Setup	2-12
Spindle Maintenance.....	2-13
Spindle Drive Belt Replacement	2-13
Outer Spindle Bushing Adjustment.....	2-18
Inner Spindle Adjustment.....	2-21
Upper Housing Disassembly.....	2-25
Inner Spindle Removal.....	2-27
Inner Spindle Bearing Replacement	2-27
Spindle Sweep Process	2-29
Spindle Wear Inspection	2-30
Setting up Rottler Flycutter with Two Inserts.....	2-31
X-Axis Bearing Adjustment	2-32
Y-Axis Gib Adjustment.....	2-33
Software Backlash Settings.....	2-34
Spindle Drive Belt Replacement / Adjustment	2-41
Mill Mode Tilt Adjustment	2-41
Replacing the Counterbalance Cylinder	2-43
Digital Micrometer Setting Instructions	2-47

Probe “On-Center” Adjustment	2-51
Replacing Motherboard Battery	2-55
Ballscrew Assembly References	2-58
Alignment Definitions for Angular Bearings and Belleville Washers	2-58
Z-Axis Lower Bearing and Belleville Stack Arrangement.....	2-59
Z-Axis Upper Belleville Stack Arrangement	2-61
X-Axis Drive-Side Bearing Arrangement	2-62
X-Axis Idle-Side Bearing Arrangement	2-63
Y-Axis Bearing Arrangement.....	2-64
Inner Spindle Upper Belleville Arrangement	2-65
Inner Spindle Lower Bearing Arrangement	2-66
Wiring, Air, and Oil Diagrams.....	2-68

Quick Reference Lubrication Chart

Refer to the maintenance section in the manual for lubrication location points and instruction.

Assembly	Frequency	Lubrication Operation	Recommended Lubricant	Date Service
Outer Spindle	8 Hours	Wipe with oil	ISO VG 68 Way Oil	
	1000 Hours	Soak felt wiper with oil		
Oil Reservoir System	8 Hours	Check upper oil lines are full	ISO VG 68 Way Oil	
	175 Hours	Fill Reservoir if needed		
Upper Z-Axis Ballscrew Pillow Block	175 Hours	Grease	NLGI #2 White Lithium Grease	
Lower Z-Axis Ballscrew Bearings	175 Hours	Grease	NLGI #2 White Lithium Grease	
X-Axis Linear Bearings	175 Hours	Grease	Showa Shell Alvania S2 or Equivalent	
X-Axis Ballscrew Bearing Housings	175 Hours	Grease	NLGI #2 White Lithium Grease	
Pendant Swingarm Hinge	1000 Hours	Grease	NLGI #2 White Lithium Grease	

Quick Reference Preventative Maintenance Chart

Refer to the procedures in the maintenance section of the manual to make or check these adjustments. Not all items listed in the table below have adjustment. The information should be recorded, and the amount of wear tracked so the part can be replaced before down time on the machine occurs.

Procedure	Frequency	Date Serviced/Comments
Spindle Sweep Adjustment	150 Hours	
Outer Spindle Bushing Adjustment	500 Hours	
Spindle Tilt Measurement	500 Hours	
X, Y, Z Auto Mode Backlash Adjustment	1000 Hours	
X, Y, Z Handwheel Backlash Adjustment	1000 Hours	
Electrical Enclosure Air Filter Replacement	1000 Hours	
Machine Level Adjustment	1000 Hours	
Spindle Drive Belt Adjustment	1000 Hours	
Inner Spindle Bearing Adjustment	1000 Hours	
X-Axis Ballscrew Inspection	2000 Hours	
Spindle Wear Measurement	2000 Hours	

Maintenance

Lubrication

Refer to images following these written instructions:

Below are the directions that explain how and where to add oil to the different systems.

 **CAUTION** Do not overfill any of the lubrication points, serious electrical damage may result.

Outer Spindle

The Outer Spindle is hard chromed and is supported in tapered, cast iron spindle bushings. The Outer Spindle supports the Inner Spindle, bearings, seals etc. and maintains the boring rigidity.

Every 8 hours:

The Outer Spindle needs to be moved down to the lower limit, wiped clean, and then lightly coated with a ISO VG 68 Way Oil. This is very important, if the spindle is allowed to operate dirty the cast iron dust will act as an abrasive on the spindle chrome. This will cause the spindle to wear prematurely.

Every 1000 Hours:

Open the sheet metal cover from the front of the spindle unit. Remove the 4 flat head bolts holding the felt wiper retainers (1) in place. Lift or drop the retainer to access the felt wiper.(2) Soak the felt wipers (2) with ISO VG 68 Way Oil. Reinstall the felt wiper retainers.(1)

Note: Do not adjust the nut below the felt wiper (see the mechanical section for correct adjustment of this nut).

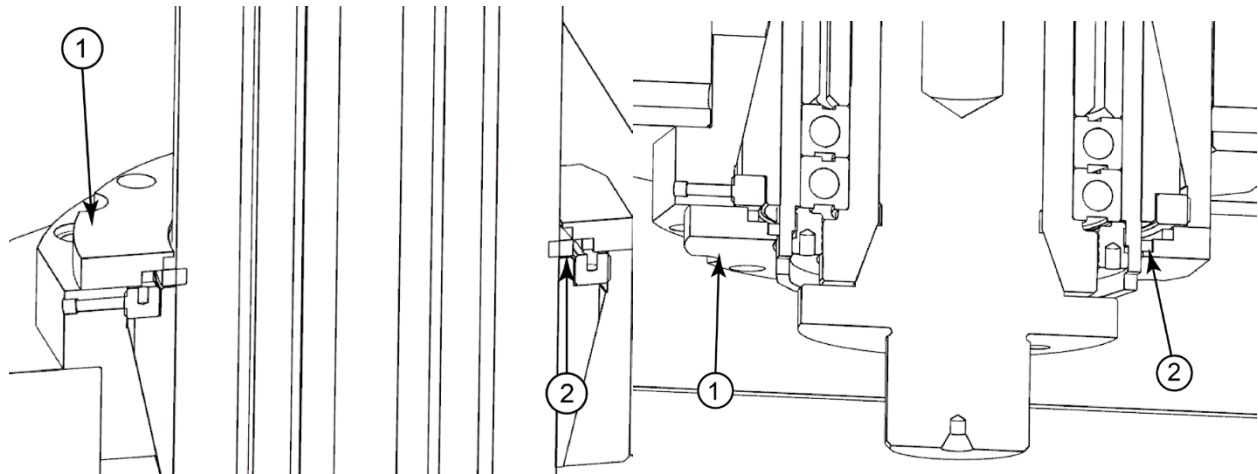

Oil Reservoir System

Every 8 hours check the oil supply lines to the upper spindle to be sure they are full of oil.

IMPORTANT

The oil reservoir system is located on the lower portion of the column. This system lubricates the following:

- Linear Bearings
- Y-Axis Ways
- Y-Axis Ballscrew
- Inner Spindle Bearings (Upper and Lower)
- Horizontal Ballscrew
- Outer Spindle
- Z-Axis Ballscrew

Every 175 Hours:

The oil level of the reservoir should be checked and filled with **ISO VG 68 WAY OIL**.

When the oil reservoir is low or empty on the EM103/4/5H machine, the control panel will show “LOW OIL” and will not run until the reservoir has been filled.

The oil system is set for automatic oiling after 1,000 inches of travel. The setting can be changed by clicking the Setup Software tab, then the Distance Traveled Pulse in the drop-down box. A pop-up box will appear where you can change the amount of travel before and for how long the oiler activates.

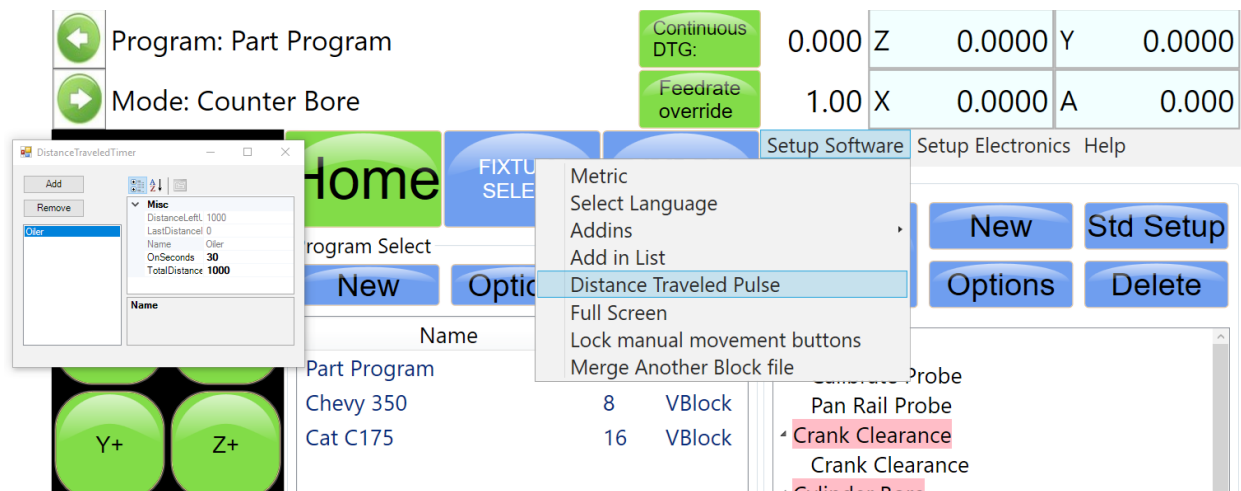

Inner Spindle Bearings

The Inner Spindle Bearings are lubricated from the oil reservoir system. It is normal for a small amount of this oil to seep through the spindle bearings and onto the cutterhead.

Z-Axis Ballscrew Bearings

The Upper Pillow Block bearing is located on the top plate just below the driven sprocket. The lower bearing set is located at the bottom of the ballscrew in the spindle base.

Every 175 Hours:

These bearings should be greased with NLGI 2 White Lithium Grease.

X-Axis Linear Bearings

Every 1000 Hours:

Grease all 4 linear rail trucks with 4-6 pumps of grease, then move the column 3 feet in the positive and negative directions and give it 4-6 more pumps of grease. These bearings should be greased with Showa Shell Alvania S2 grease or equivalent.

Priming Spindle Base Oil Lines

1. After the spindle base has been placed on the column the oil lines must be purged of air.
2. Remove the oil lines located on the spindle base guide rails.

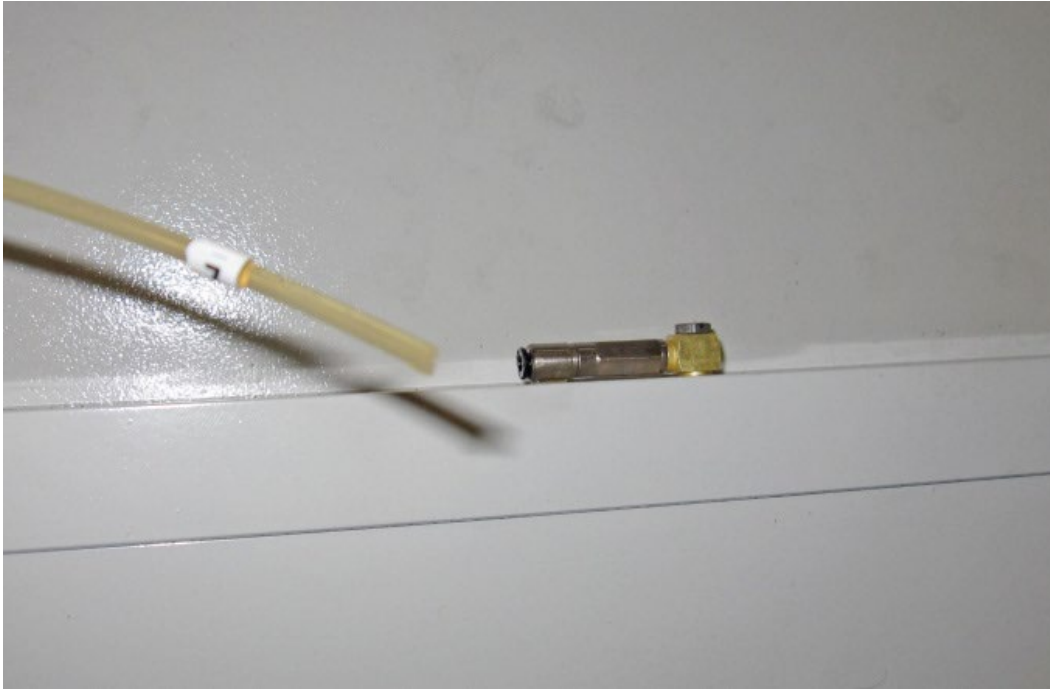

3. Energize the IO bit for the oiler on the computer and wait for oil to flow out of the line.
4. Reattach oil lines.

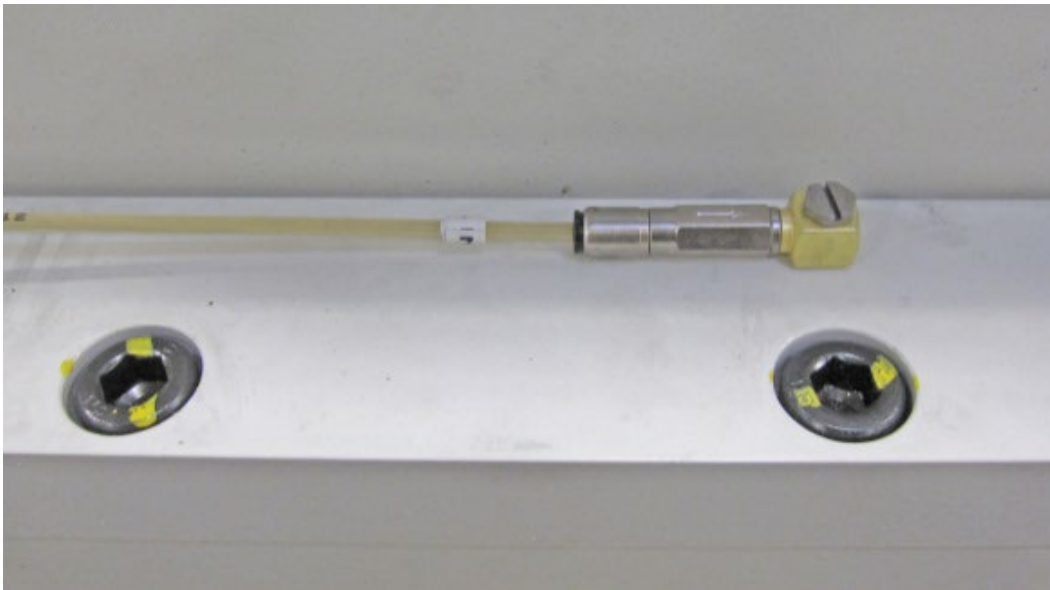

Lubrication Locations

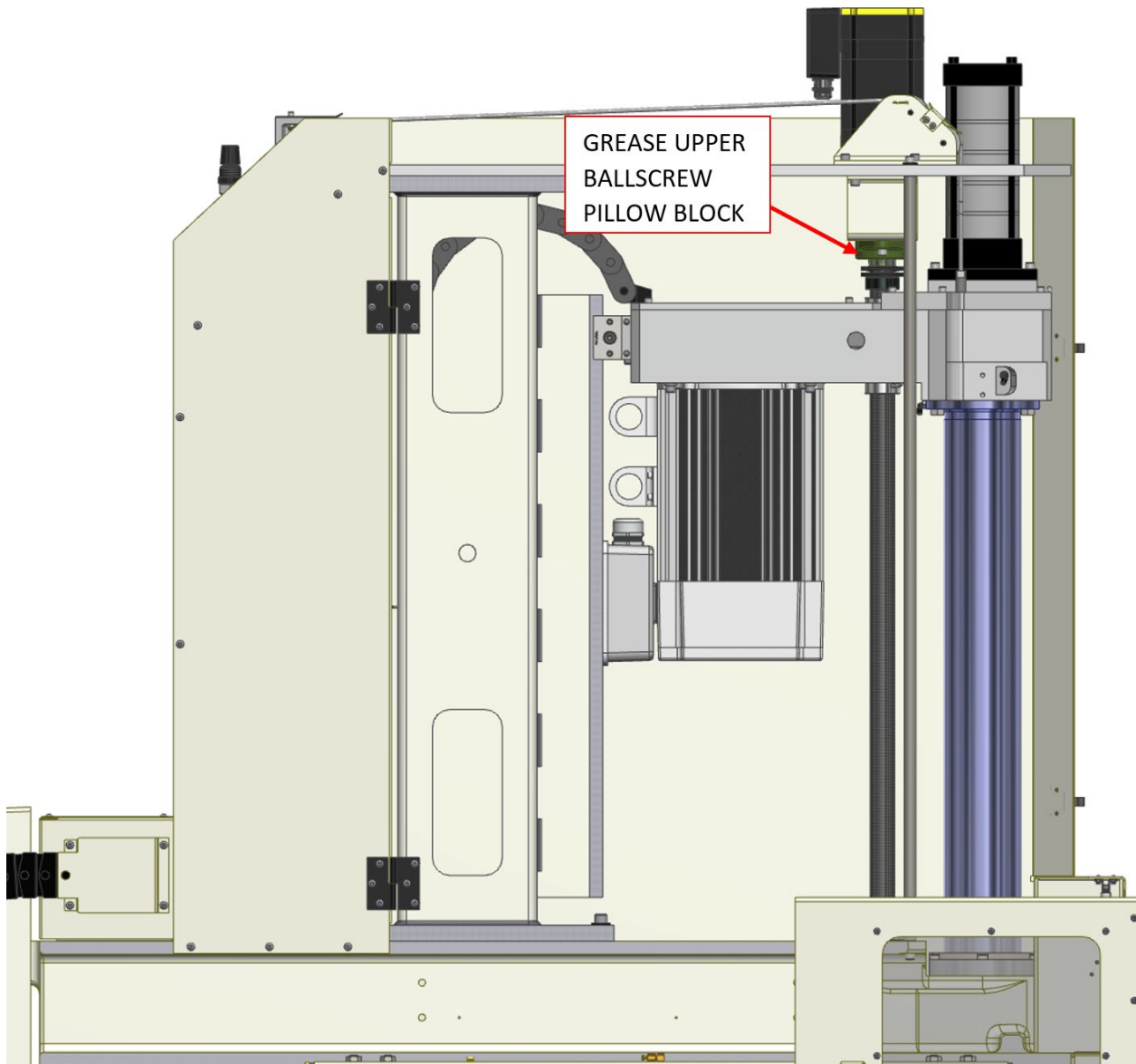

Lubrication Locations (cont.):

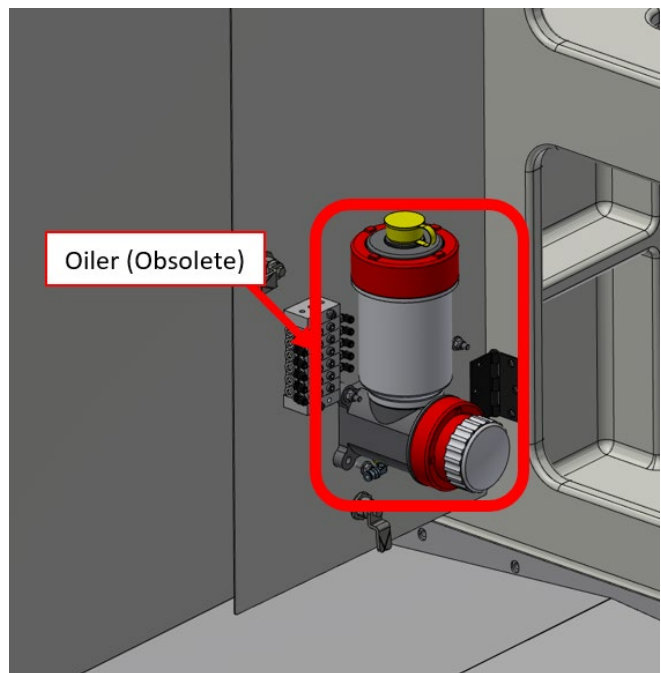
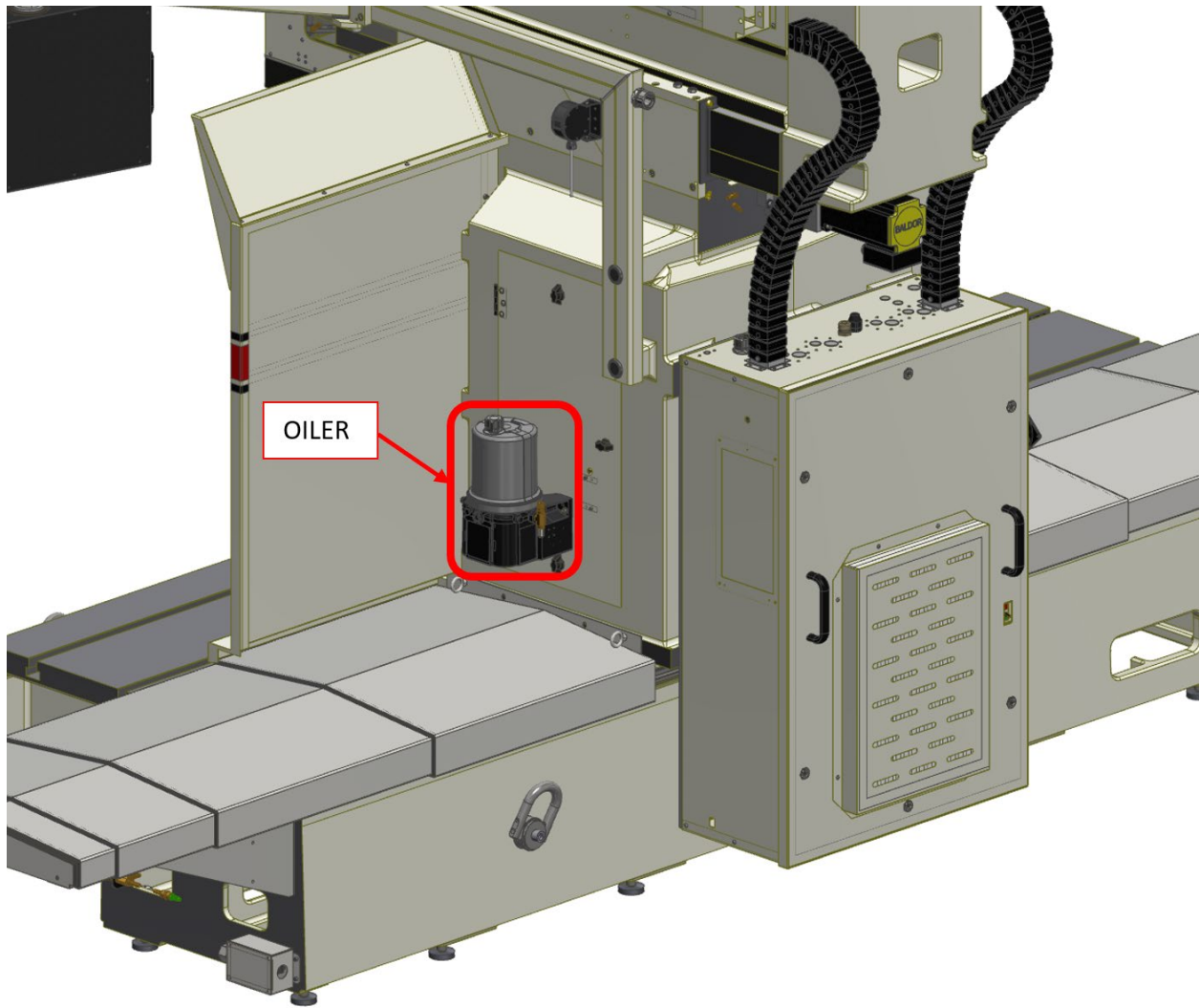

Right Angle Drive Lubrication

All right-angle drives require lubrication at the point where the pinion drive intersects with the drive gear. This is generally in the area where the cutterhead is attached, except for the units that have belt drive. There will be a small pipe plug that is removed to check oil level and add oil if needed. See illustration below for general locations.

With the drive mounted on the machine spindle, the oil level should be even with the bottom of the pipe plug threads.

All Rottler Right Angle Drives are filled with Union 76 Turbine Oil 68 prior to shipment. Use this or an equivalent ISO VG68 oil if the need to add or change oil arises.

When adding oil, fill until oil starts to run out of fill hole. Allow excess oil to drain, then coat pipe plug threads with anti-seize compound and replace it.

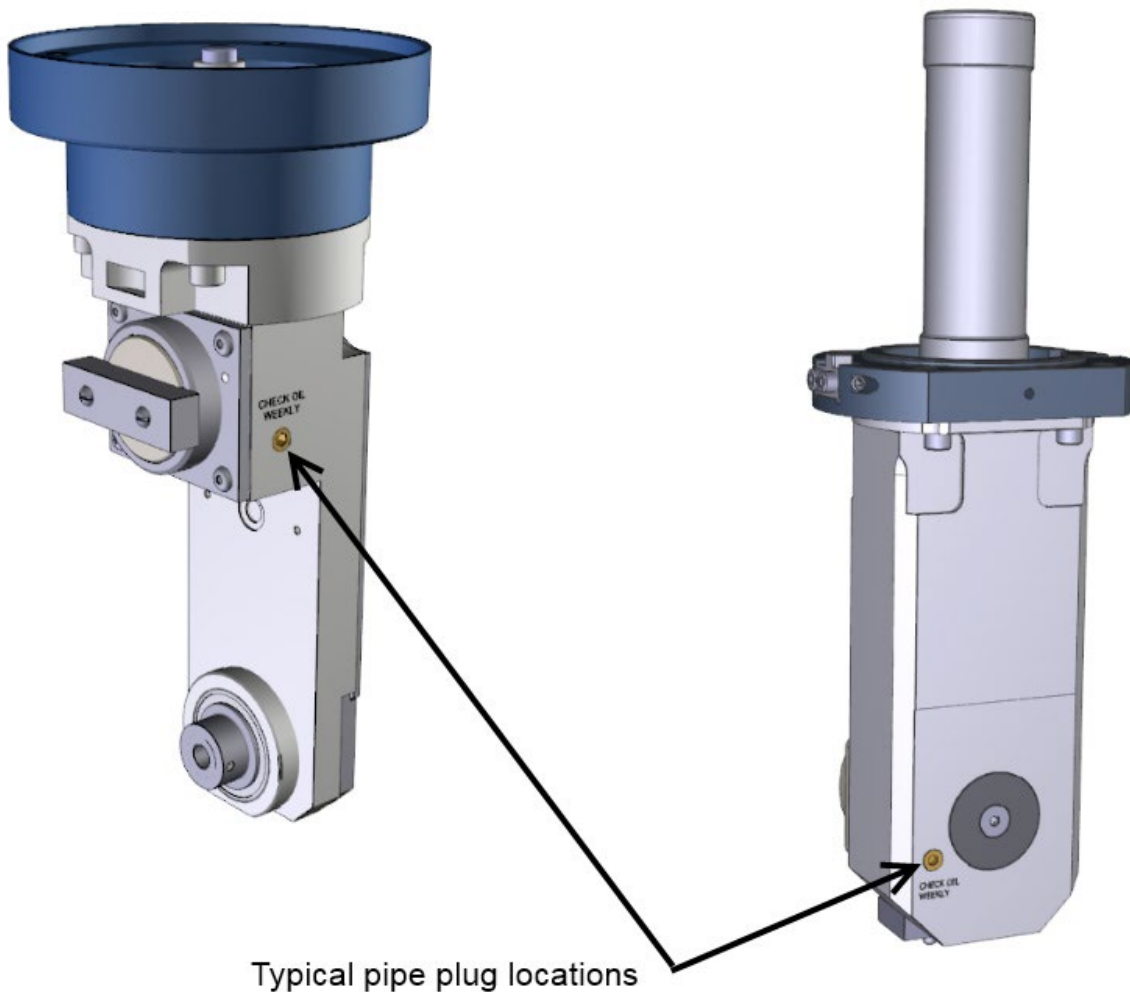

Tool Changer Setup

This will cover tool changer set up. This procedure should be done only by skilled personnel. In this procedure the machine will be making automatic moves, this requires knowledge of other item setup and access to the software setup. Improper setup can cause damage to the tool holders or sheet metal of the ATC.

1. Add the Umbrella ATC into the software through the addin list.
2. Reboot the software for it to take effect
3. Home the machine
4. Create a new Block program, we will refer to ours are "TC1"
5. Add a general bore program to the block program
6. Bring up the "Control" options screen under setup electronics
7. Access the x-y-z-s axis's and under status tab use the GOTO button and move them all to "dro" 0
8. Go into general bore Mode
9. Zero the axis in the general bore mode on the actual dro soft limit Axis zeros. See Bulletin 318 (may help you when setting up the tool changer)
10. Move the changer with the control options screen to the 1st tool spot. (Make sure you protect against falling tools with plywood/rags)
11. Access the addins Umbrella ATC setup set the numbers as shown, for a starting point.

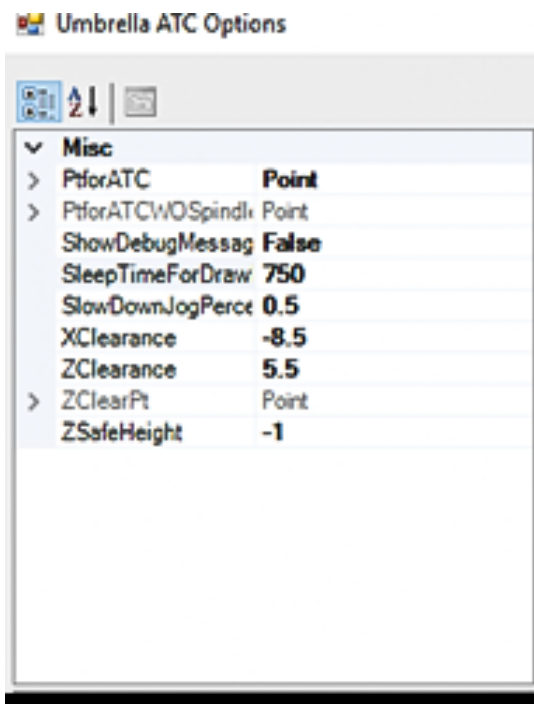

12. Install a tool in the spindle.
13. Use the hand wheel and move the tool into the fingers, make sure the tool pick up/drop off is correct. (Make sure the spindle is oriented correctly May need to change in the PtforATC in options.)
14. Use the Set TC position button to set the spot. (Verify that the settings changed in the PtforATC tab)
15. Release the tool and move the spindle up to verify the distance needed to clear the retention knob but keep the access door open, if there is a chip door. Verify your Z-clearance, standard is about 5.5
16. Move the machine z-axis back down onto the tool. Verify your settings for the tool pickup are correct.
17. While gripping the tool move the machine away from the ATC until the chip door closes. Verify your X-clearance, standard is about -8.5 (- mounted on the right-hand side + for the left-hand side)

18. Set the Z Safe height. This is height that it knows it can go to before it resumes a program before or after a tool change. (Suggest using 0 until you are comfortable with the changer.)
19. SlowDownJogPercent 0.5 is 50% speed 1 is 100% speed 1.5 is 150% speed
20. Sleptimefordrawbar in milliseconds 1000 is one second standard is 750ms of dwell time.
21. Enter in 2-3 tools in table of tools, click add a tool.

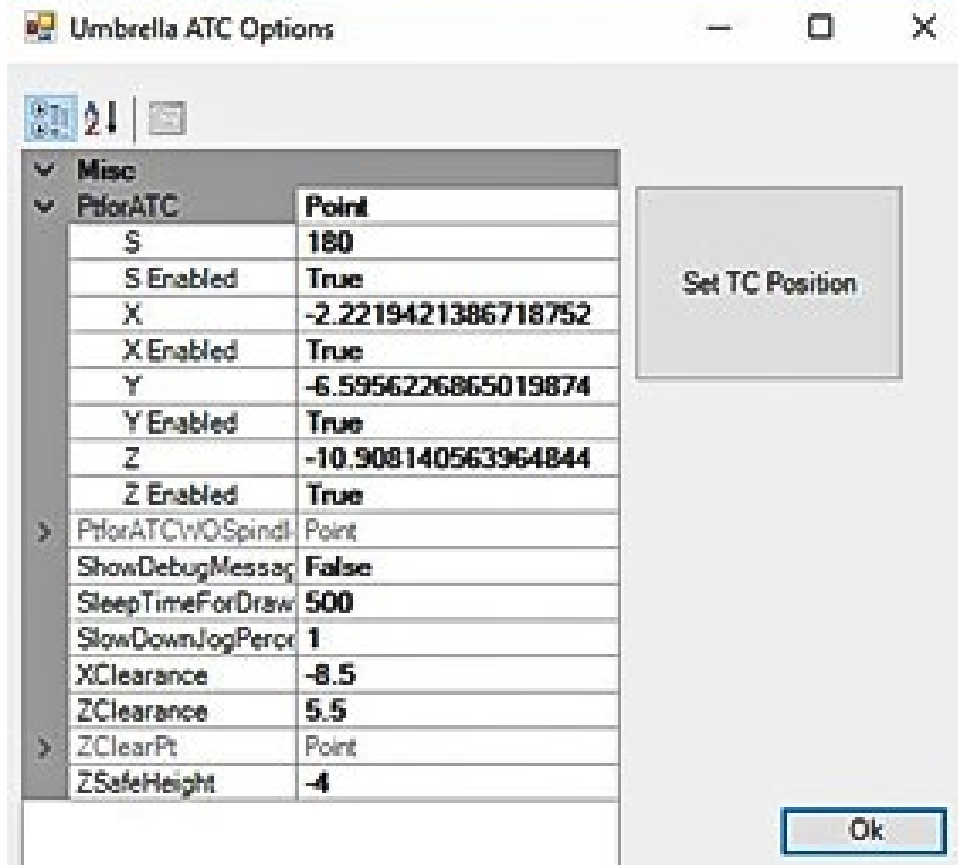
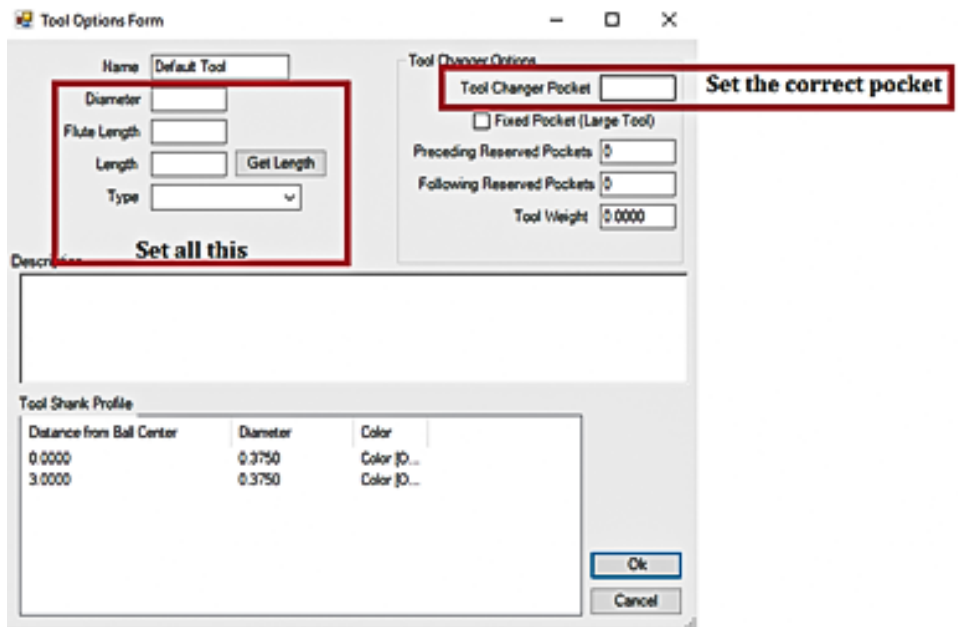

22. Try a tool change with a light tool.

Magnescale Indicator Set Up

- Turn off power to Magnescale by unplugging the connector on the back of the unit. Or having someone else shut off the power while you stay in front of the unit.
- Plug it back in while you are holding down the reset button. You will see either “mm” or “in”
- While the still holding the reset button down, press the mode button and both the “mm” or “in” will start blinking, you are now in edit mode.
- You can now release the reset button, use the up arrow to switch between “mm” and “in” hit the set button to lock in the selection

Setting Up Sensor Stroke Depth.

Press and hold set and mode until options menu starts blinking. Push mode once to switch to rSLP and then press up arrow to set +.0005.



- Push set once, and then mode ONE time, then rSL should be blinking
- Press and hold set and mode until options menu starts blinking. Push mode once to switch to rSL and then press up arrow to set +.0002.



- Push set once, and then mode button.



- Should be set to rEF > OFF
- Push mode button once.

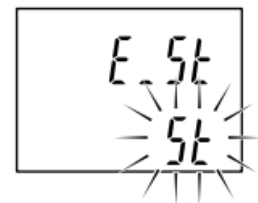

- Should be set to E_St > St
- Push mode button once. You should be back to the main readout screen
- Depress the plunger it should go from zero to max of .2000-2500

Spindle Maintenance

Drawbar Maintenance

Preventative Maintenance

Every Week:

- Check the packing ring in the clamp unit (visual check)
- Check the gripper for damage or dirt
- Check that the gripper

Every 6 months, or 200,000 tool changes:

- In Tool Release position, check dimension E.M. according to the diagram on the below
- Test the Drawbar force (Rottler recommends using the Power Check tester)
 - Nominal drawbar force is 28 kN (6300 lb)
 - If the drawbar force is small than 19.5 kN (4400 lb), follow these steps:
 - Regrease the drawbar and re-test
 - Check the belleville stack for broken washers, replace as needed and re-test
 - Replace the gripper and re-test
 - Replace the drawbar assembly

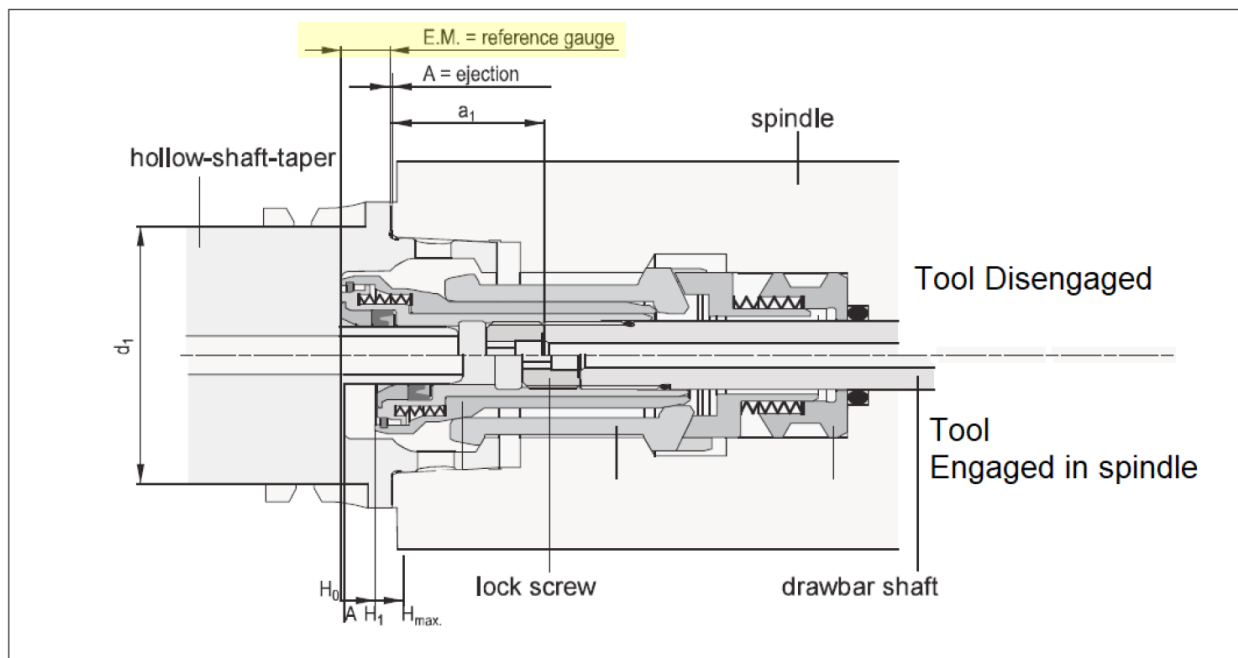

d₁ (Taper)	A80
A	0.5mm (0.019in)
E.M.	13mm (0.5118in)
H_{max}	11mm (0.433in)
H₁	8.3mm (0.326in)
a₁	31.5mm (1.2401in)

Spindle Drive Belt Replacement

CAUTION Turn off power to machine before proceeding with this procedure.

The spindle drive belt is located in the upper spindle housing.

To adjust the belt tension, it is only necessary to loosen the Motor Mount bolts, the 1in hole in the housing allows for a belt tension gauge to be used.

Open or remove the Spindle Door.

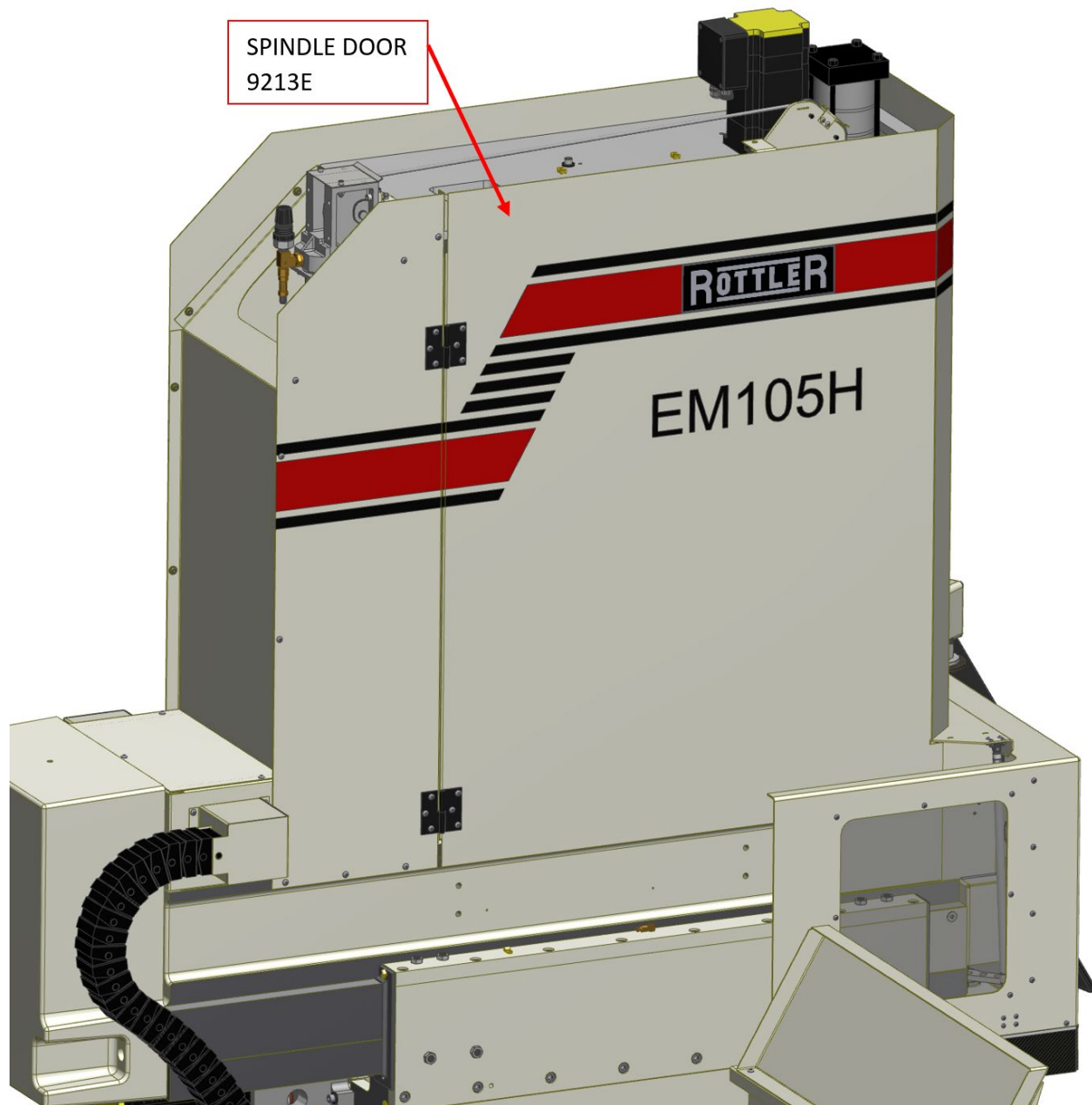

Lower spindle down onto a piece of wood to prevent the motor from falling.

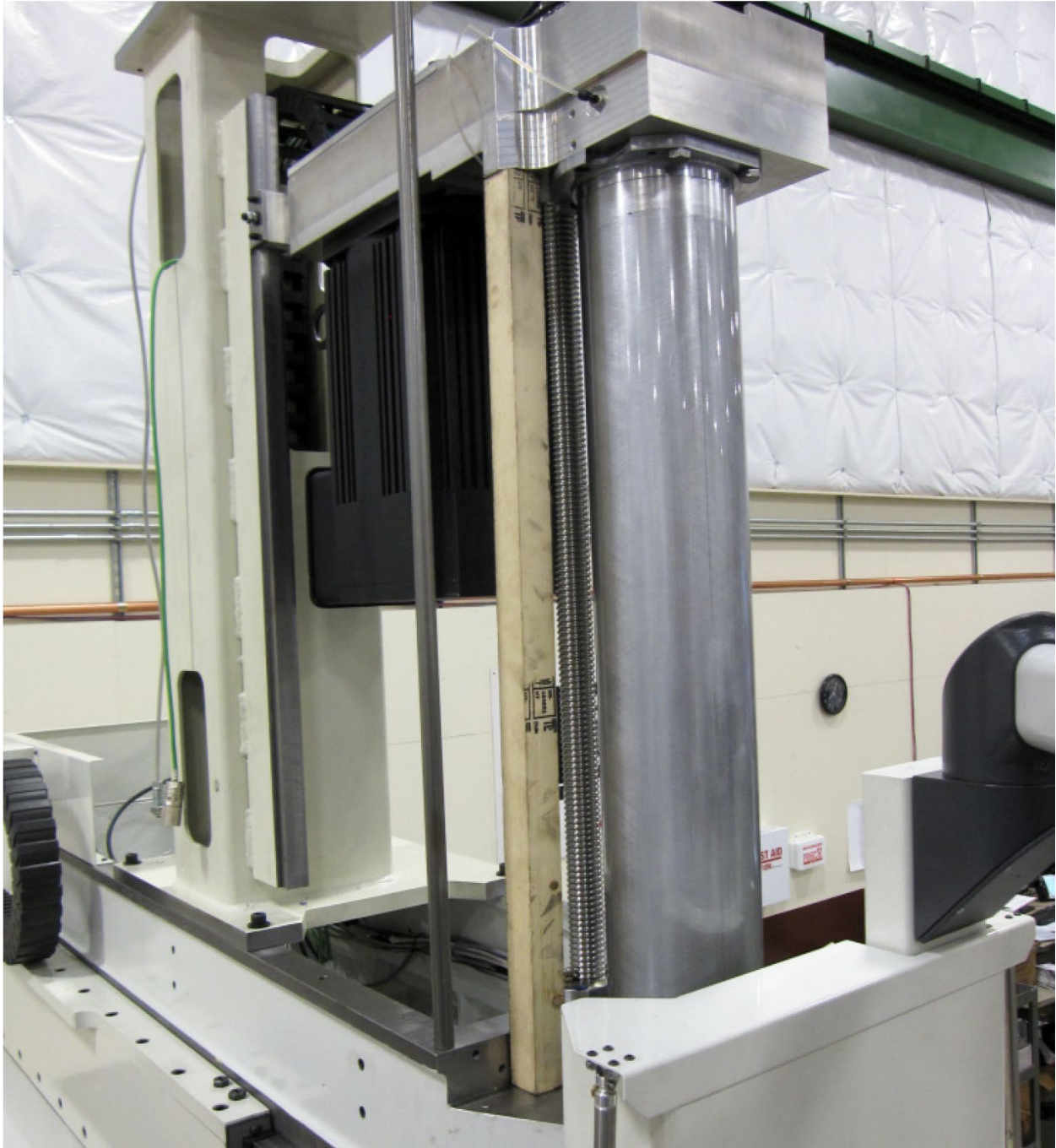

Carefully remove the air pressure from the counterbalance cylinder.
Remove the counterweight cable end from the upper housing.

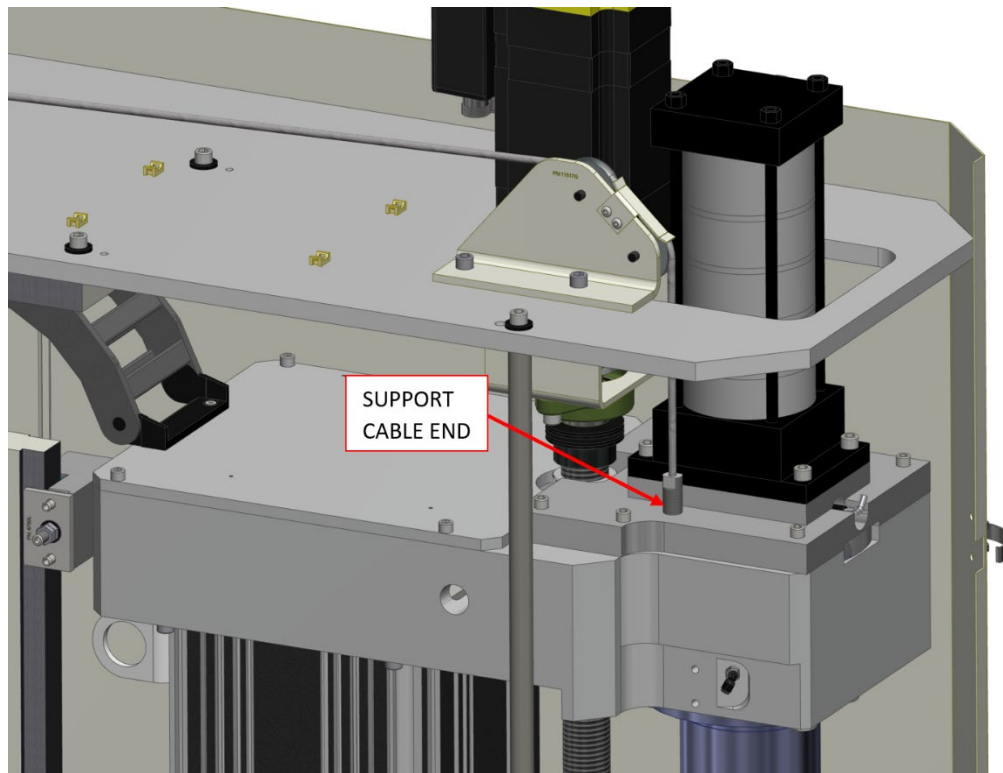

Remove Z-Axis motor and Ballscrew bracket.

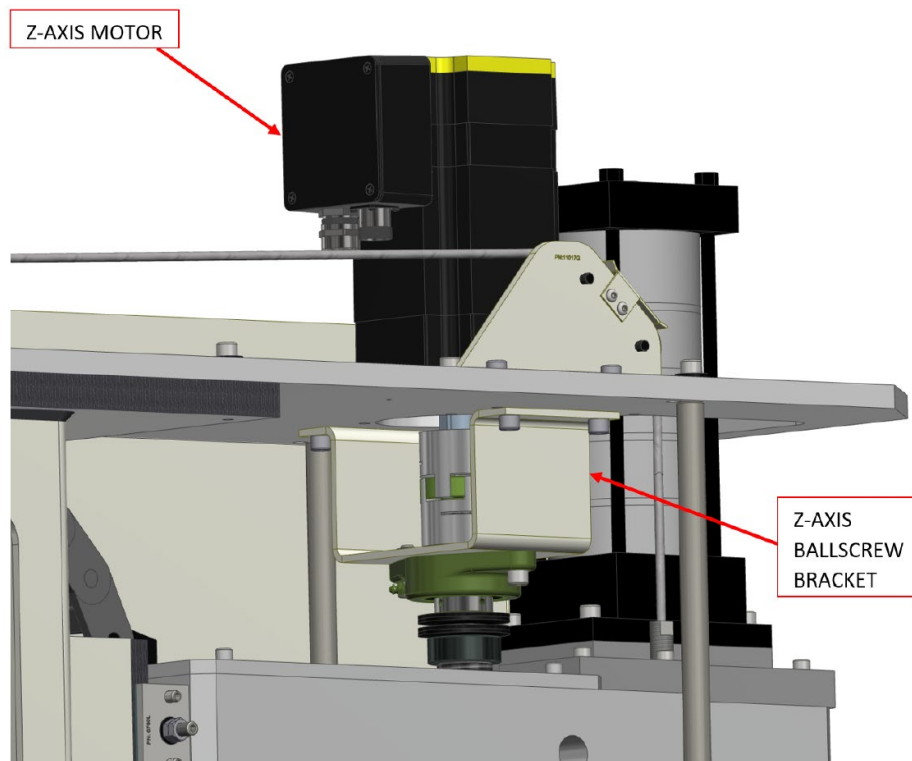

Disconnect the Drawbar cylinder and remove the Front and Rear Housing cover plates.

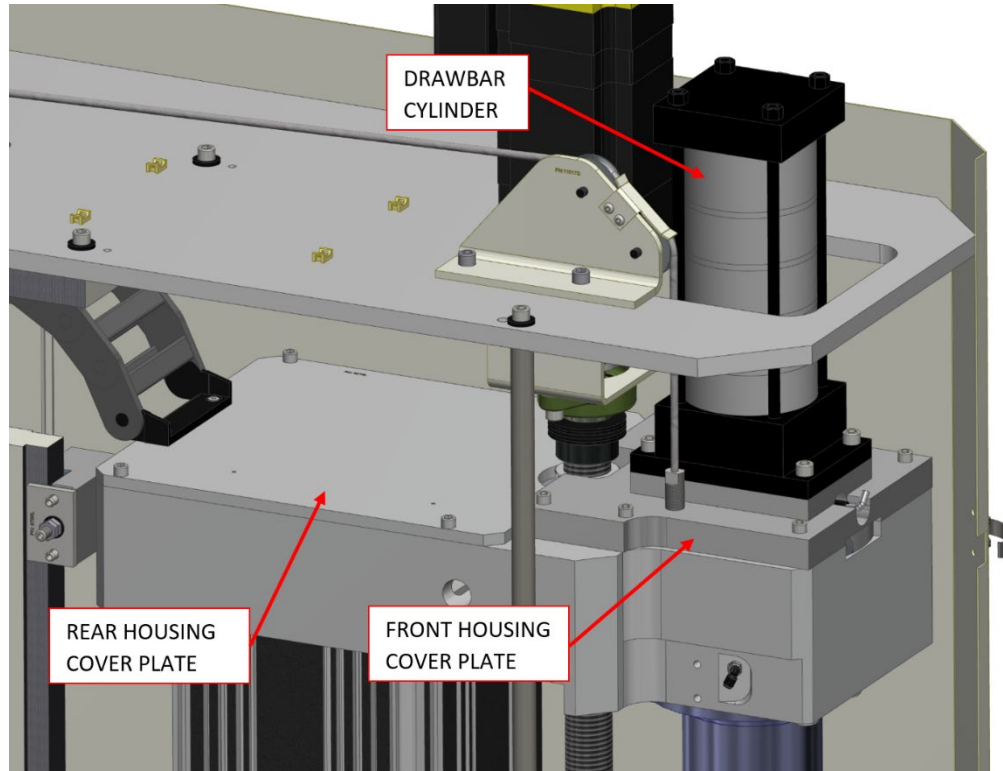

Loosen motor mount bolts and belt tension adjusting bolt.

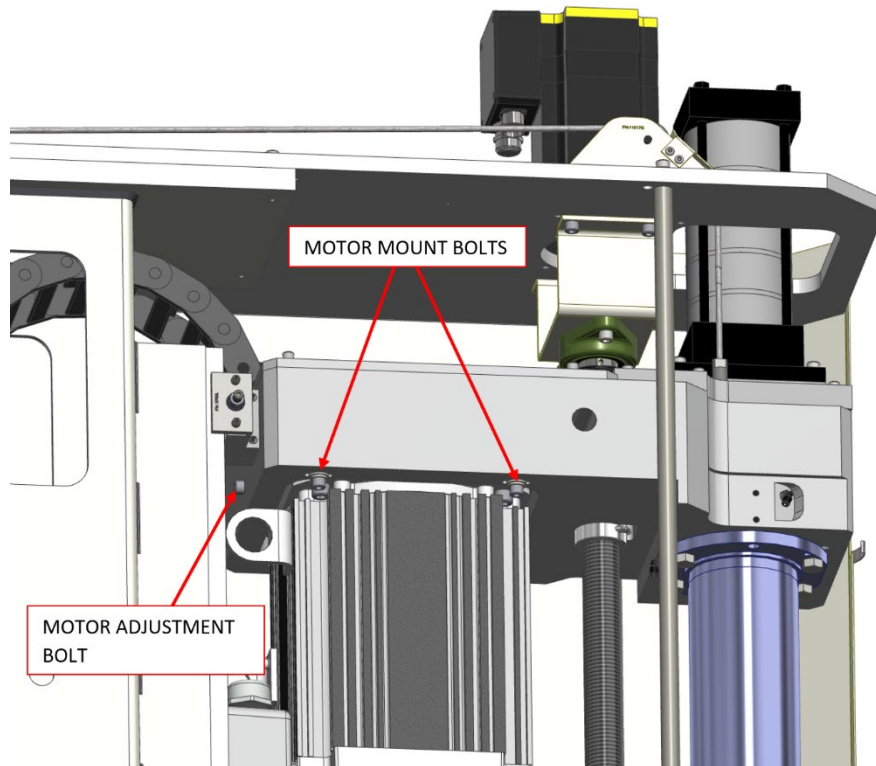

Remove and replace belt.

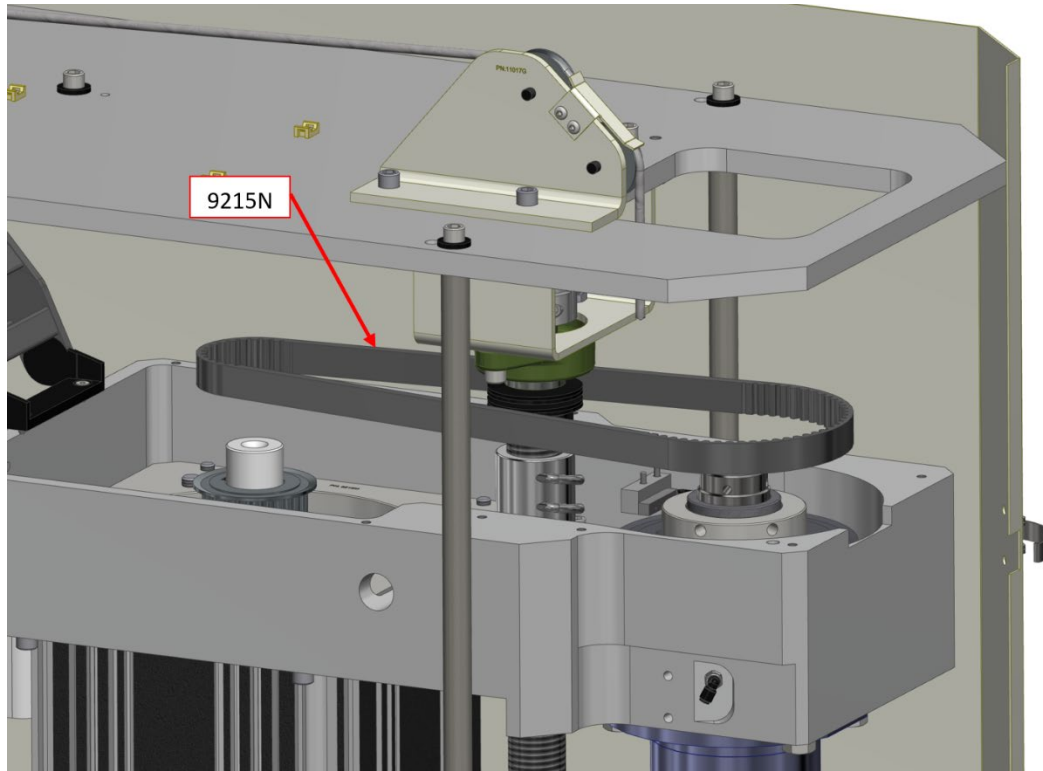

When the new belt is in place use the adjusting bolt to set the belt tension. Proper tension is when there is 0.22in (5.6mm) of deflection when 8.7-9.3 lbs. of force is applied between the 2 pulleys.

Outer Spindle Bushing Adjustment

NOTE* Do the spindle sweep procedure before tightening the outer spindle bushings. Refer to spindle sweep for details.

1. Start the Rottler software.
2. Pull up the graph by selecting Setup Electronics (1), then select Control (2), which will bring up the Control Options box.
3. In the Control Options box select Z (3) which will bring up the Z Status box.
4. Select Current Graph (4).

The screenshot displays the Rottler software interface with several windows open to illustrate the steps for accessing the Z Status box and the Current Graph.

Top Panel: Shows "Program: Part Program" and "Mode: Calibrate Probe". A "Continuous DTG" value of 0.000 and a "Feedrate override" of 1.00 are visible. The coordinate readout shows Z: 0.0000, Y: 0.0000, X: 0.0000, and A: 0.0000.

Main Panel: Features buttons for "CHANGE TOOL", "Home", "FIXTURE SELECT", and "TABLE OF TOOLS". A "Setup Software" menu is open, with "Setup Electronics" selected. A sub-menu is also open, showing "Control" selected.

Control Options Window: A table lists various links and their status:

Name	Link #	Bad Packets	Bad DV	BadPac...	LinkSer...
X	0	0	0	NaN	0
Y	1	0	0	NaN	0
Z	2	0	0	NaN	0
S	3	0	0	NaN	0
C	9	0	0	NaN	0
Umbrella	8	0	0	NaN	0
Outputs	6	0	0	NaN	0
Inputs	5	0	0	NaN	0
Power	11	0	0	NaN	0
IO 9	9	0	0	NaN	0
Encoder Read...	10	0	0	NaN	0

Z Status Window: Shows various settings and status for the Z-axis. The "Current Graph" button is highlighted with a red box.

Current Graph Window: Displays a graph titled "Show Smoothing" with a y-axis ranging from 0.0 to 1.2 and an x-axis ranging from -5 to 0. The graph shows a flat line at 0.0.

5. Before adjusting be sure that the spindle is well lubricated.
6. Move the spindle to middle of its travel in the Z-axis.

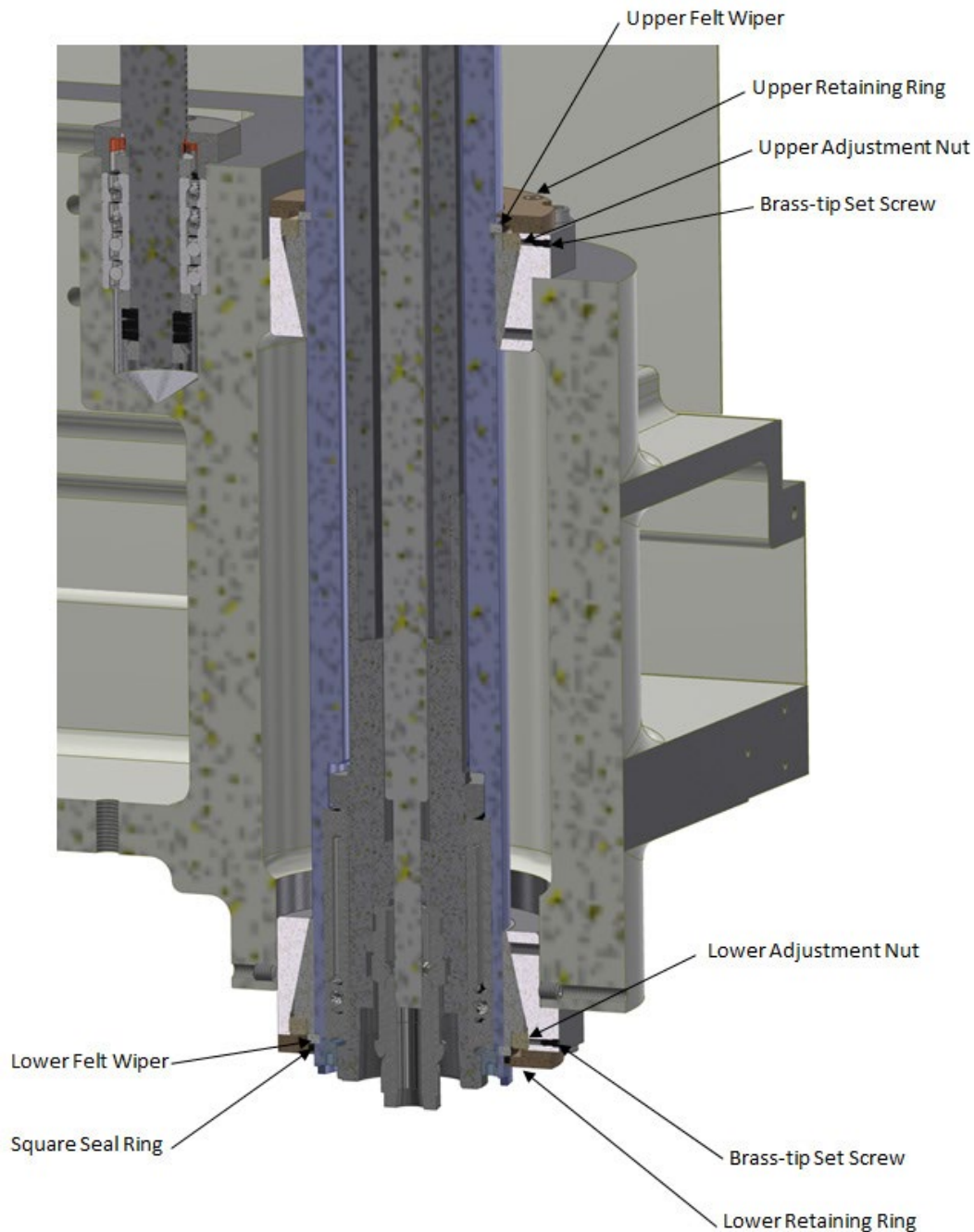

7. Unscrew the (4) 10-24 X 5/8 FHCS in the upper retaining ring, and move the ring/felt aside
8. Unscrew the (4) 10-24 X 5/8 FHCS in the lower retaining ring, and remove the retaining ring, Square ring, felt.
9. Loosen the brass-tip set screws in both the upper and lower bearing retainers
10. Loosen both upper adjustment nut and lower adjustment nut $\frac{1}{4}$ turn, move up and down 5" 5 times.
Note the loosened amperage _____ (.5-1.5)
11. Move the spindle to middle of its travel in the Z-axis
12. Move the spindle up 5", then using a 3/16 pin punch and a 24oz metal hammer, tighten the lower adjustment nut (6223) until an increase of .25amps on the graph is noted.
13. Move the spindle to middle of its travel in the Z-axis

14. Move the spindle down 5", then using a 3/16 pin punch and a 24oz metal hammer, tighten the upper adjustment nut (6223) until another increase of .25amps on the graph is noted.
15. With both adjustment nuts tightened a total of .5 amp over the noted amperage above should show on the graph
16. Tighten the (2) brass-tip set screws in the upper and lower bearing retainers
17. Reinstall the upper felt and the upper retaining ring (4) 10-24 X 5/8 FHCS
18. Reinstall the lower felt, and square ring then upper retaining ring (4) 10-24 X 5/8 FHCS. Replace felt or square ring if worn out.

Inner Spindle Adjustment

 **WARNING** FOLLOW ALL SAFETY PROCEDURES LISTED IN THE SAFETY SECTION OF THIS MANUAL BEFORE STARTING THIS PROCEDURE

Open the spindle base door.

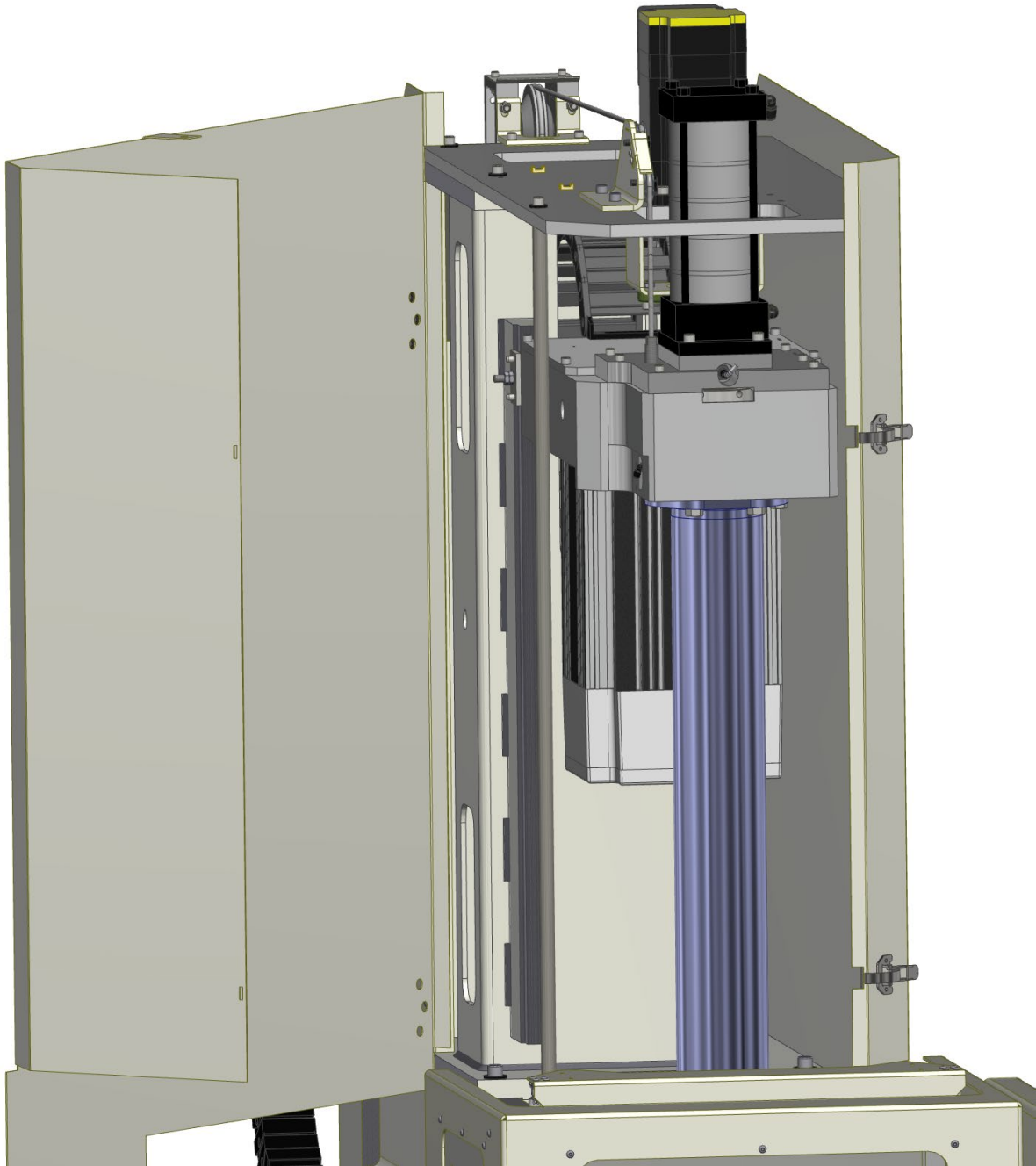

Install a fly-cutter or boring cutter-head with long tool holder into spindle.

Locate opening in the belt housing.

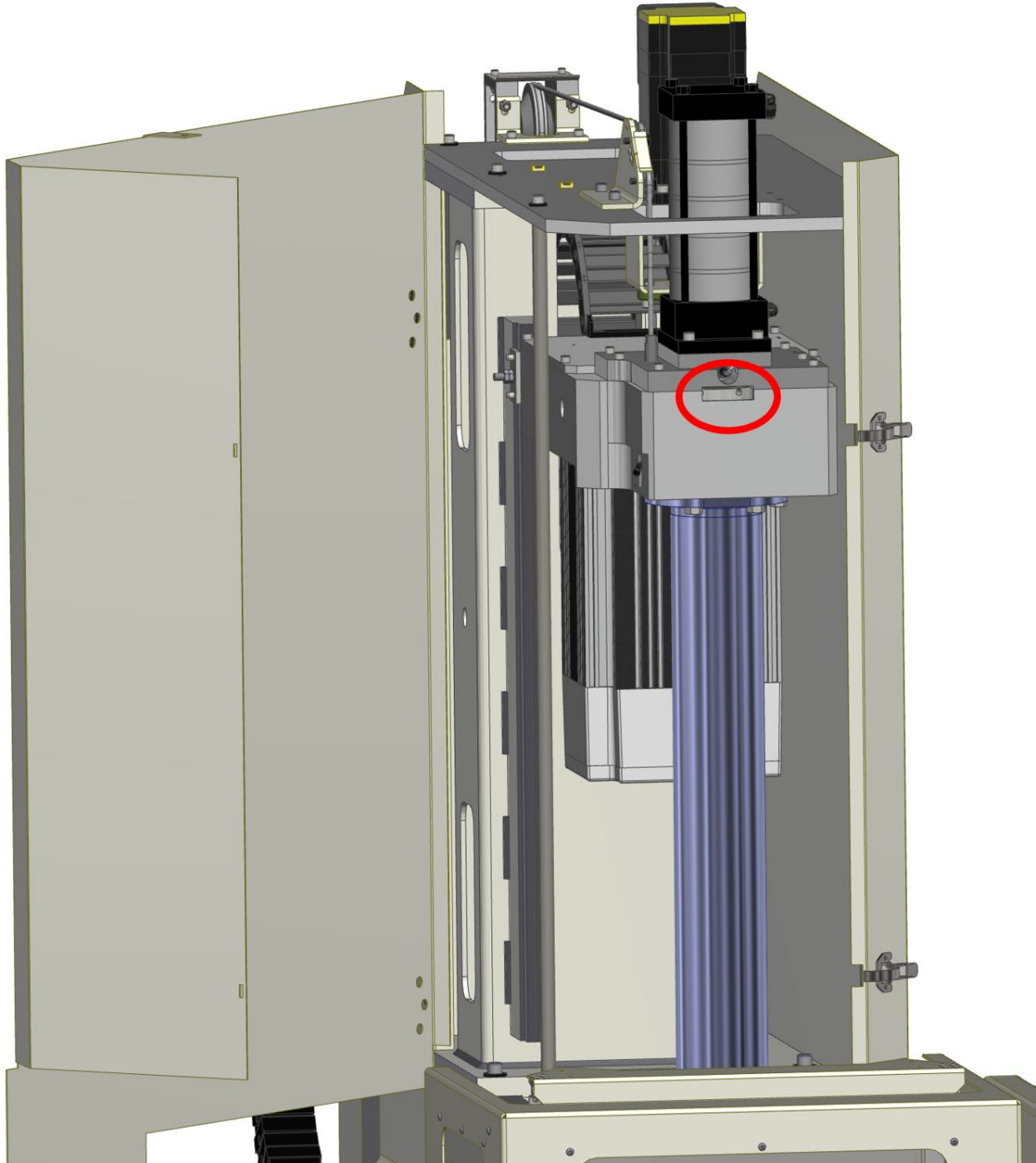

Insert a rod into one of the drilled holes of the adjustment nut. This is used to lock the adjustment nut in place so that the nut will not turn while the inner spindle is turned.

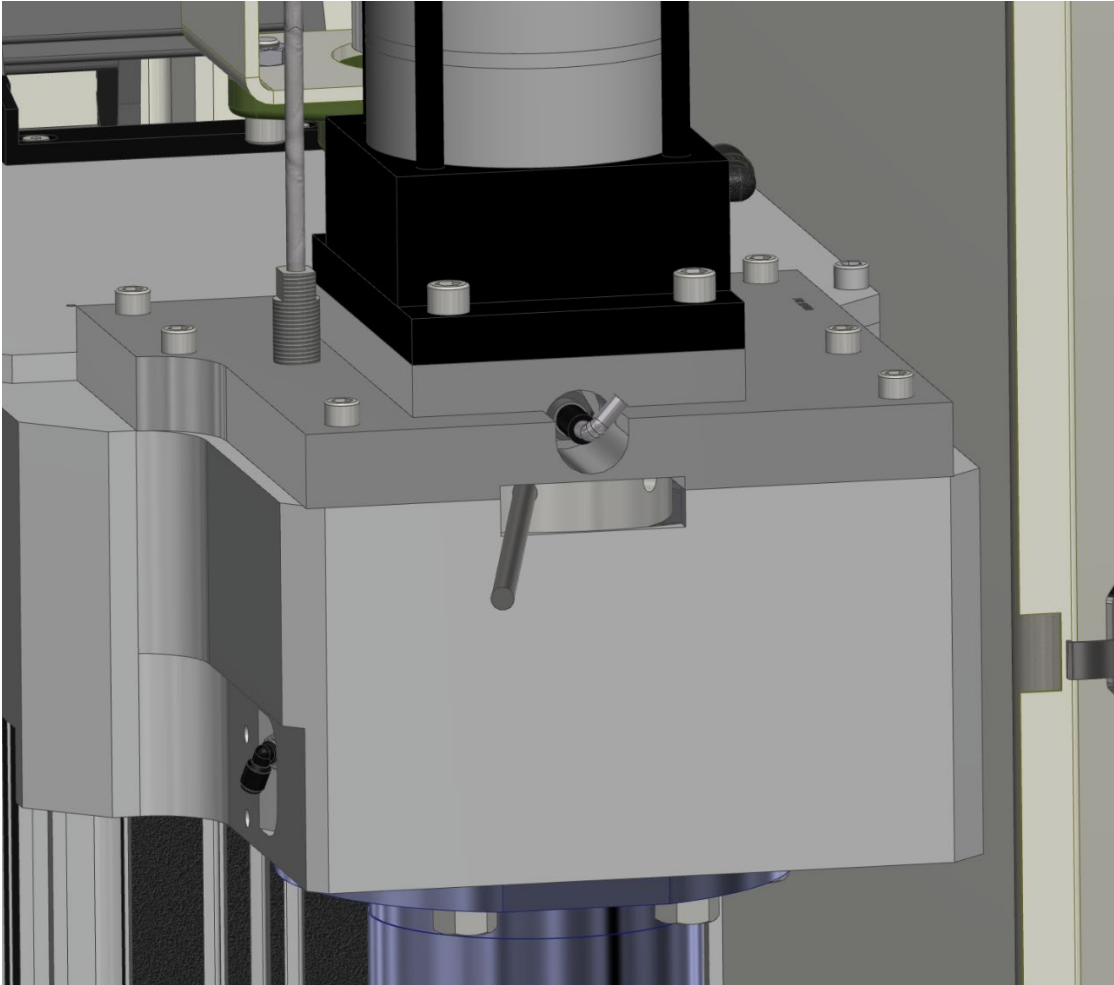

Hold the cutterhead and turn it one turn clockwise to loosen the inner spindle adjustment.

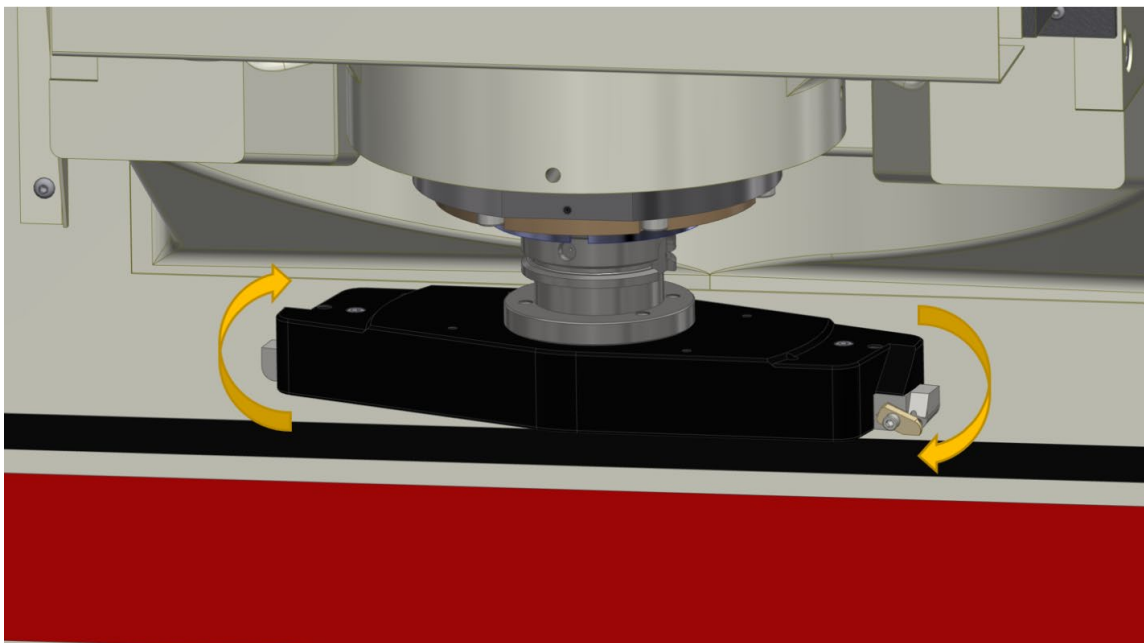

Now turn the cutterhead counterclockwise. You will feel an increase of resistance as the spring load of the inner spindle increases. Continue to tighten until there is a sudden increase in effort to turn the cutterhead. At this point the inner spindle washers are fully compressed.

CAUTION *IMPORTANT: DO NOT OVER TIGHTEN, SEVERE BEARING DAMAGE WILL OCCUR AND REPLACEMENT WILL BE NECESSARY*

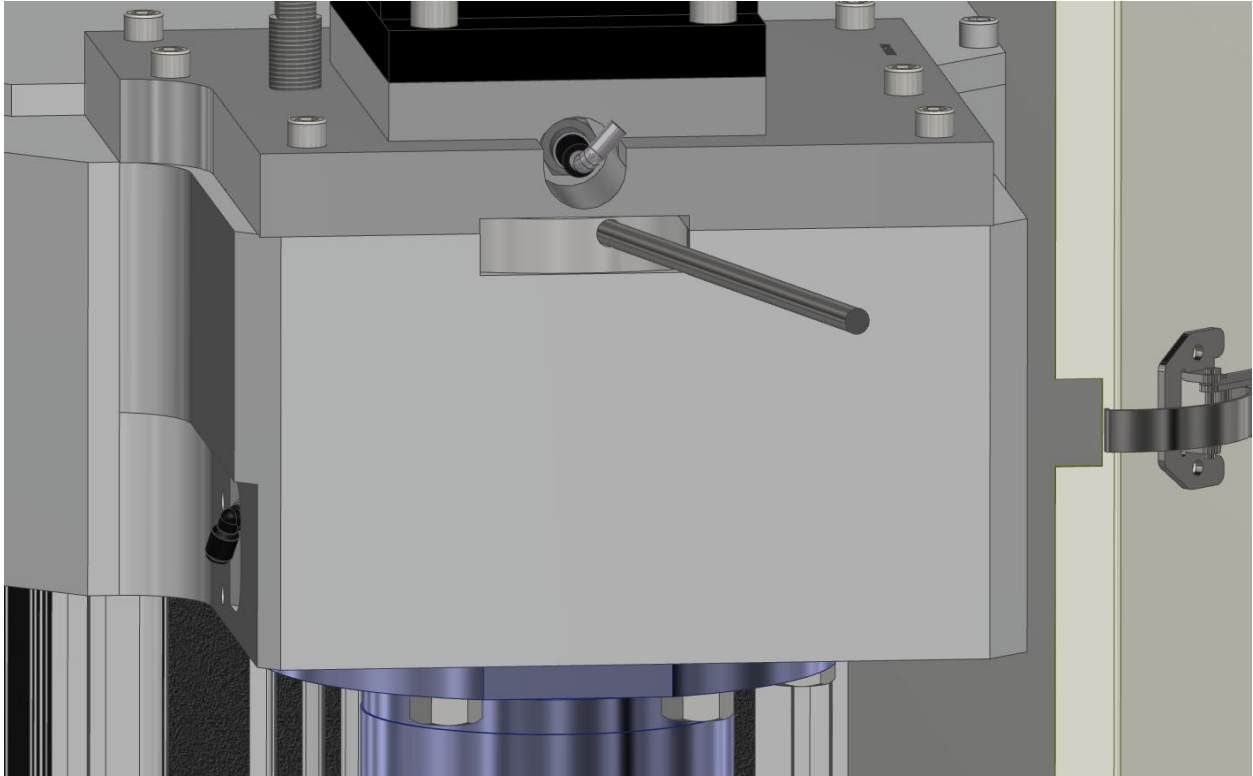

Now turn the cutterhead clockwise until you feel the detent ball on the adjusting nut lock into place.

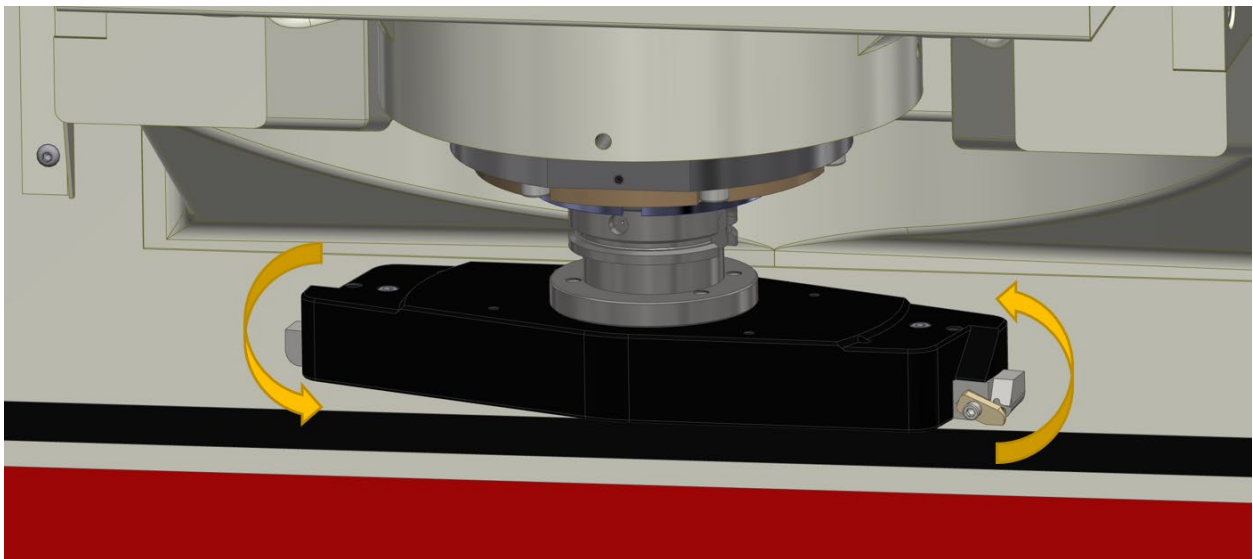

The inner spindle is now adjusted.
Remove the rod from the adjustment nut and close the spindle cover door.

Upper Housing Disassembly

Remove the spindle base door and right-side cover.



Disconnect all power and air to the machine before continuing, severe bodily injury may occur.

Remove the (4) bolts holding the Rear belt cover on and the cover.

Pull on the Counterbalance cable to verify that it is not under tension

IMPORTANT!: Do not proceed unless or until the counterbalance cable is loose.

Remove the counterbalance cable from the Drawbar Cylinder Mount Plate.

Note: When reassembling, be sure not to thread the cable in too far as it may come into contact with the driven pulley.

Disconnect the air to the Drawbar Cylinder and remove the (6) bolts holding the Cylinder Mount plate. Remove and set aside the Drawbar Cylinder and mount plate.

Loosen the (4) bolts of the Motor Adjustment Plate and the belt tensioning bolt at the back of the housing. Push the motor toward the spindle to loosen the drive belt

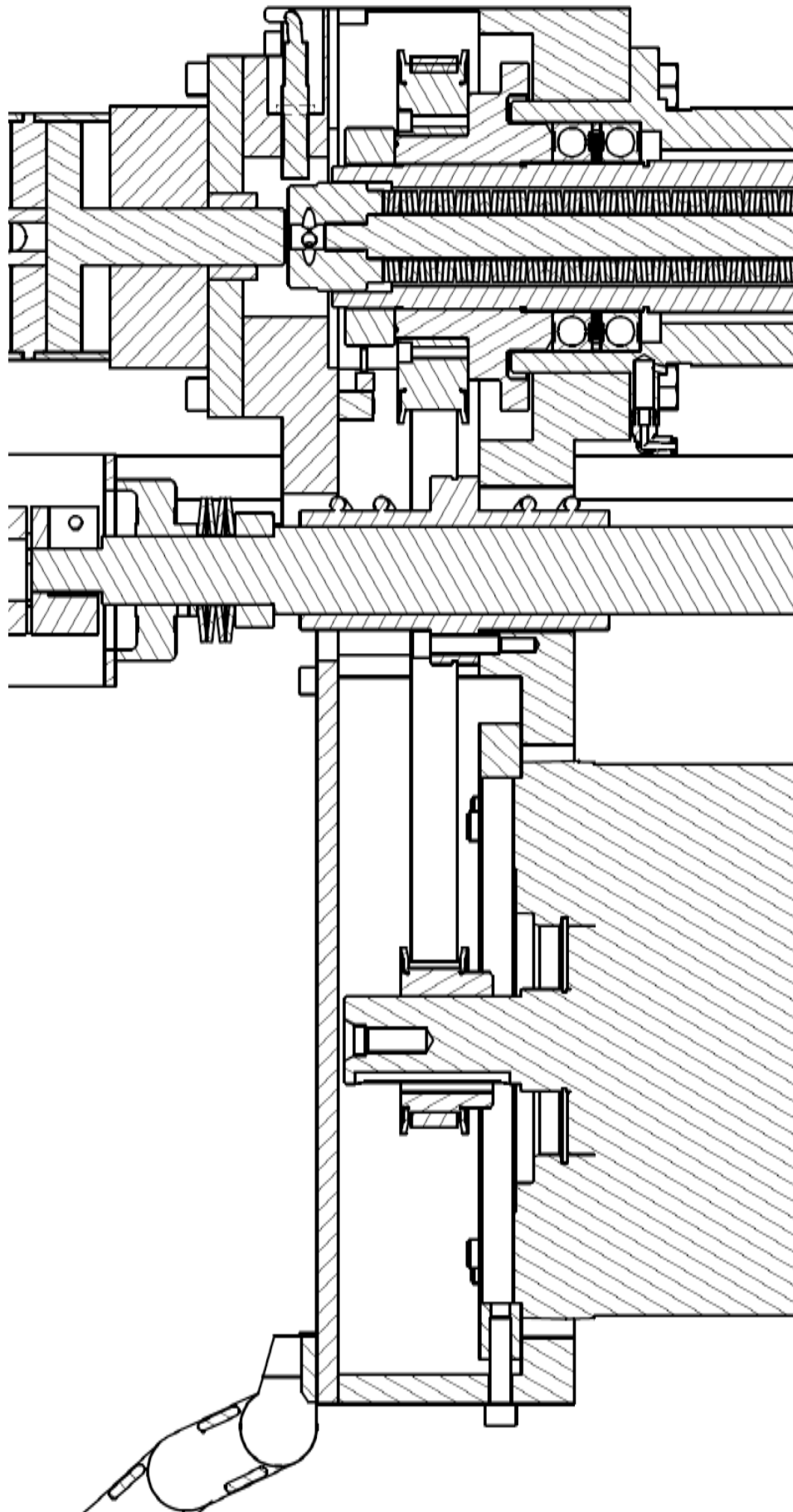

Inner Spindle Removal

Prior to following these instructions, perform the steps in Upper Housing Disassembly.

IMPORTANT: When removing bearings, bellevilles and spacers, note the direction they come off for correct reassembly. The driven pulley and inner spindle adjustment nut must be in place before continuing. Remove the LEFT-HAND THREAD throwback ring (6305D) from the bottom of the outer spindle.

Note: If the driven pulley and inner spindle adjustment nut are not in place the inner spindle will be able to fall out of the outer spindle.

While supporting the inner spindle from the bottom, remove the inner spindle adjustment nut and driven pulley from the top. The inner spindle is now free to be removed from the bottom. This spindle is precision fit into the outer spindle, it may be necessary to tap the top of the inner spindle with a soft face mallet to get the spindle to drop out.

Note: Be sure of the thrust direction of the bearings on reassembly.

Reassemble in the reverse order.

Inner Spindle Bearing Replacement

Prior to following these instructions, perform the steps in Upper Housing Disassembly and Inner Spindle Removal.

Loosen the three (3) Allen head set screws on the shoelock nut (6116F).
Loosen the shoelock nut and slide off of the top of the spindle.

Note: Be very careful not to damage the threads when sliding nuts, bearings and sleeves off the top of the inner spindle. These are very fine threads used for the inner spindle adjustment nut.

Remove the top bearing by tapping lightly and evenly on both sides of the bearing. After the bearing is moved slightly off of the spacer set (6172E) tap the inner race.

Note: Tapping on the outer race can cause it to roll off of the bearings. Generally after removing the bearings from the inner spindle they are not suitable for re-use.

Remove the spacer set.

Remove the two lower bearings (6116E) set of three (3) the same way as the top bearing.

Stand the spindle on end so that the bearing pack is nearest the floor.

Make sure inner spindle is free of all dirt and debris.

Lightly coat the lower bearing pack area with a light weight #10 oil.
If you have a bearing heater available to you, it is the preferred method of bearing installation. If not, follow the instructions below.

Slide the two (2) lower bearings onto the inner spindle with the correct bearing thrust direction until they stop. Use a small brass punch to lightly tap each side of the bearing on the inner race until both bearings are seated at the bottom of the spindle.

Install the spacer set.

Install the top bearing using the same procedure as the lower bearings until it is seated against the spacer set.

Indicate the bearing set to within .0005" all the way around. Adjust the spacer set by tapping the high side lightly with a brass drift.

Install the shoelock nut and tighten with a spanner wrench until the inner races of the bearings and spacer set are fully seated together.

Tighten the three (3) set screws on the shoelock nut.

Place the inner spindle in a vise near the bearing pack and lock the vise.

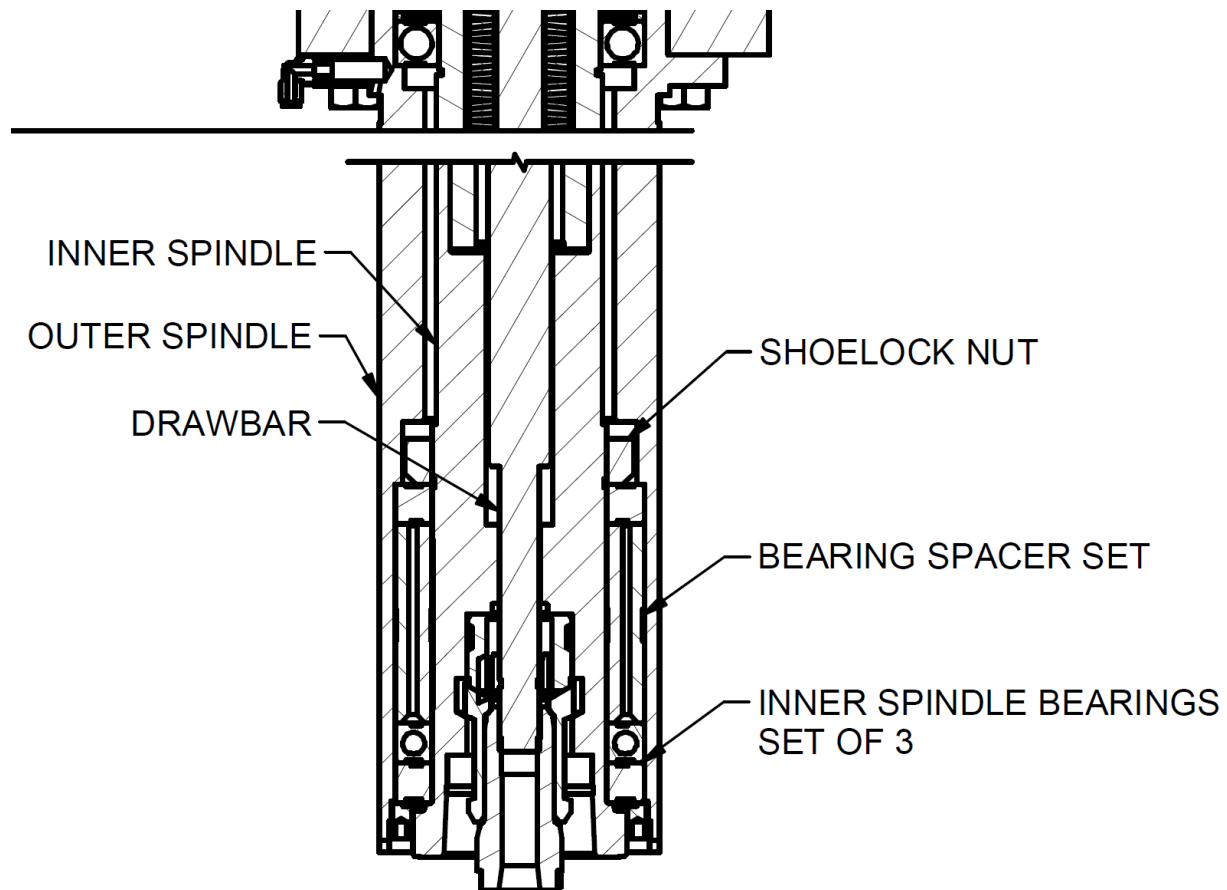

Spindle Sweep Process

The outer spindle must be swept into the main bed of the machine to achieve accurate bores.

Remove all fixturing from the machine bed, clean and stone if needed.

Install a boring cutterhead into the machine.

Install the sweep are into the cutterhead.

Bring the machine down until you have about .005" pressure on the indicator.

CAUTION Disconnect all power and air to the machine before continuing, severe bodily injury may occur.

Turn the sweep arm to the 9 O'clock position. Zero the indicator here.

Loosen the 6 socket head cap screws on the lower spindle hub. You do not want them all the way loose, just snug.

Use the four (4) set screws in the spindle base to move the spindle until the indicator reads within .0005" with a full 360-degree sweep of the indicator.

Note: You do not want the right-hand side of the spindle to be more positive than the left, it will interfere with the automatic tilt of the machine when in Mill mode.

Once the spindle is swept in tighten the six (6) socket head cap screws and double check that the sweep did not move.

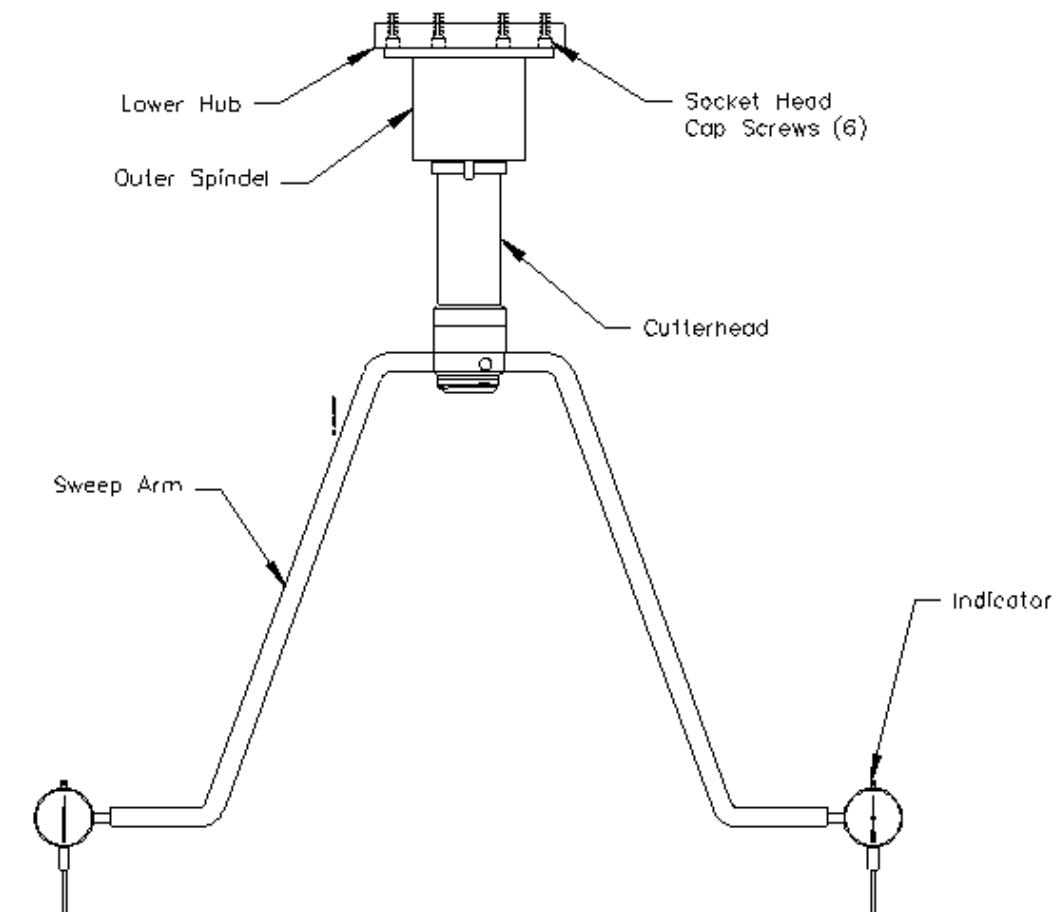

Spindle Wear Inspection

This inspection process can determine if the outer spindle or its bushings may need replaced.

For reference, the nominal diameter of the outer spindle when new is 4.436"

Required tools: 4.5in (115mm) Micrometer, A camera (smart phones work well). It is important that the camera images are capable of showing the cross-hatching on the spindle clearly.

Follow these steps to determine what, if any, action is required:

- Move the Z-Axis to the lowest end of its travel
- Measure the outer spindle diameter at 1 inch, 1 foot, and 2 feet from the bottom of the spindle and record these measurements
- Take a picture showing only the bottom 1 foot of the spindle
- Take a picture showing the entire length of the exposed spindle
- Take a picture showing a section of the spindle with the least visible cross-hatching
- Compare the three measurements, if there is more than a 0.001" difference in the recorded diameter, the spindle will need replaced
- Compare the images, if the cross-hatching is not visible then the chrome is worn out and the spindle will need replaced
- If the measurements are even, but undersized, and the chrome is not worn out then the spindle bushings may need replaced

When requesting replacements, it is necessary to send the images to Rottler for verification.

Setting Up Rottler Flycutter With Two Inserts

1. Travel the spindle to the center of the machine bed.
2. Go to the Rottler home screen on the machine before proceeding.
3. Remove the cutter head shroud from the fly cutter. Attach a dial runout indicator to a cylinder head or engine block, etc.
4. Rotate cutter head and check to see that both inserts are the same distance from the center of the spindle, within .004.
5. If adjustment is necessary loosen the tool holder clamp wedge, and the height adjustment screw. Move tool in or out the required distance. Tighten the clamp wedge. Snug up the height adjustment screw. There is a set screw located at the bottom of the tool holder; it locks a dowel pin in place.
6. When the in-out adjustment is set, loosen the set screw, the pin will pop out and hit the back of the slot. Tighten the set screw. This way, when a tool holder is removed and then replaced, it will be located very nearly where it was.
7. Insert height will still need to be adjusted.
8. Rotate cutter head and check to see that both inserts are the same height within .0015-.0003. If adjustment is necessary loosen the tool holder clamp wedge, then alternately loosen and tighten the height adjusting screw and the retaining screw, until both inserts are set as desired.
9. Retighten the tool holder clamp wedge and recheck both inserts.

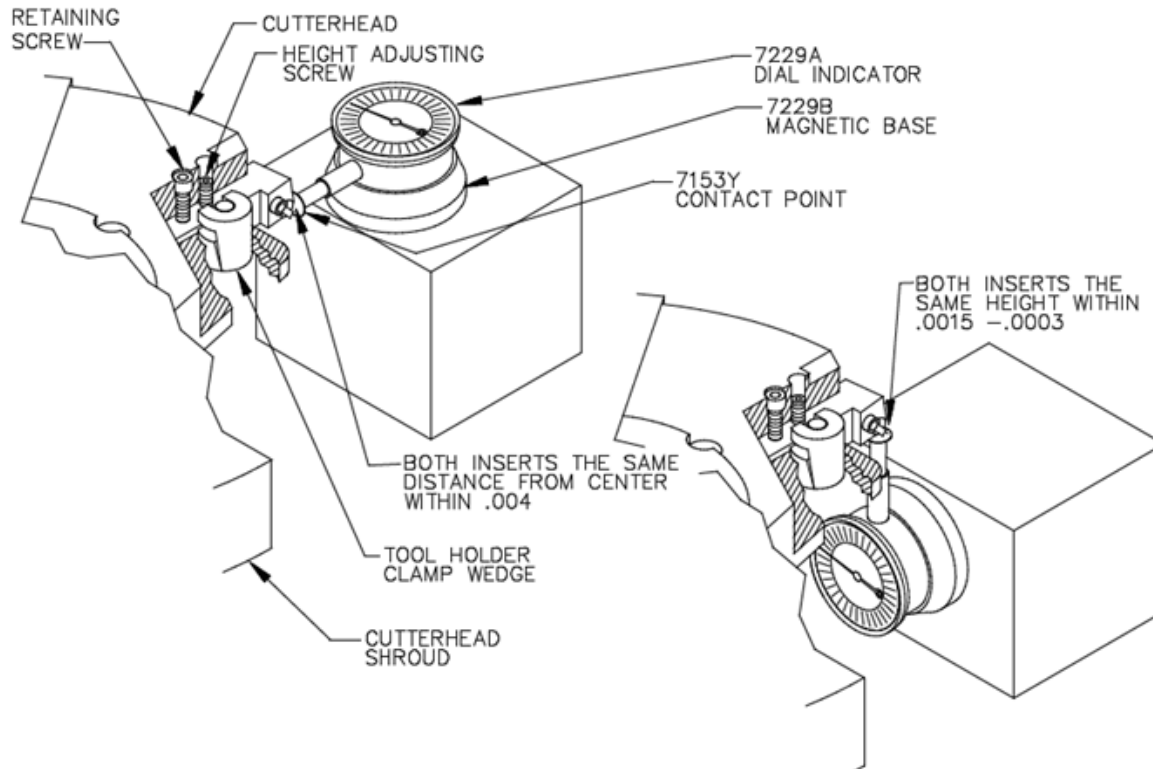

X-Axis Bearing Adjustment

The X-axis bearings are located under the main column, at the front and back. These bearings align the column to the bed and ensure that the Y-Axis moves perpendicular to the X-Axis. This alignment is critical for many machining operations that require accurate positioning of both axes.

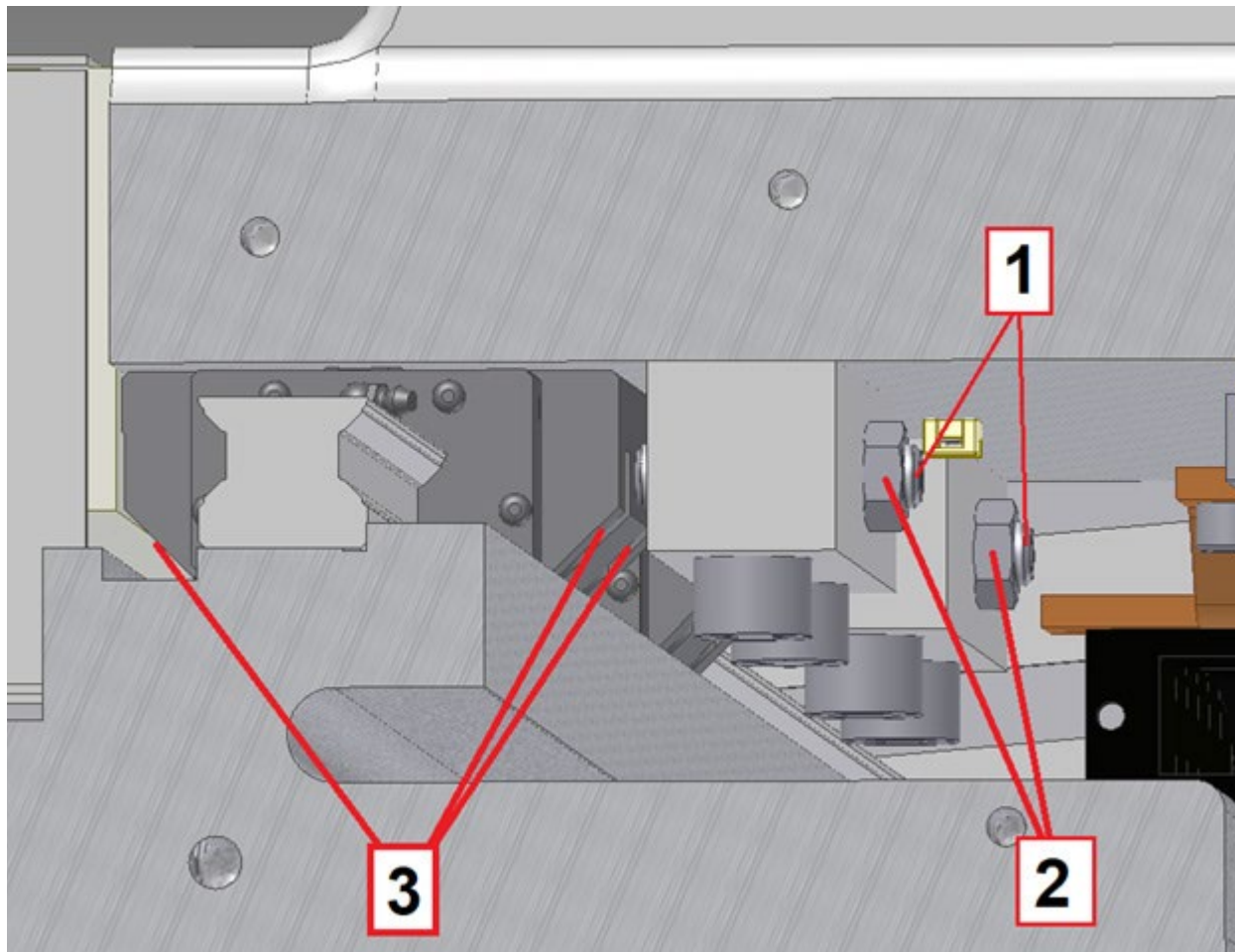

To adjust:

- Remove the front metal chip cover.
- Loosen the linear bearing bolt (3) (four per truck)
- Loosen the Lock Nut (2) on the set screw.
- Tighten the set screw (1) to 35 ft. lbs. using a correct size Allen; this will pull the Front Way bearing up against the front way while pressing the gib up against the Front Way.
- Loosen the Set Screw.(1)
- Tighten the set screw (1) to 10 ft. lbs. (120 in. lbs.)
- Lock the Lock nuts. To 35Ft. Lbs. (2)
- Tighten the linear rail truck bolt (3) (four per truck)

Y-Axis Gib Adjustment

The Y-Axis adjusting gibs are located at the top of the machine column that the spindle base is mounted on. There are gibs located on the top and side rails on the left side of the column. Two are located on the top rail and two are located on the side rail.

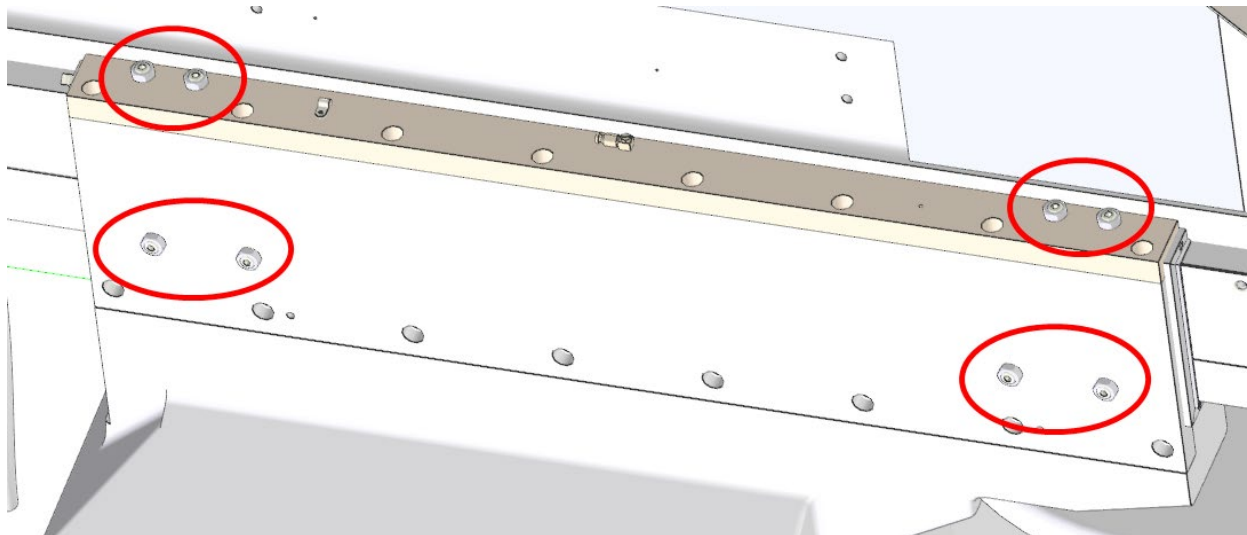

On the right side of the column there are gibs located on the top rail.

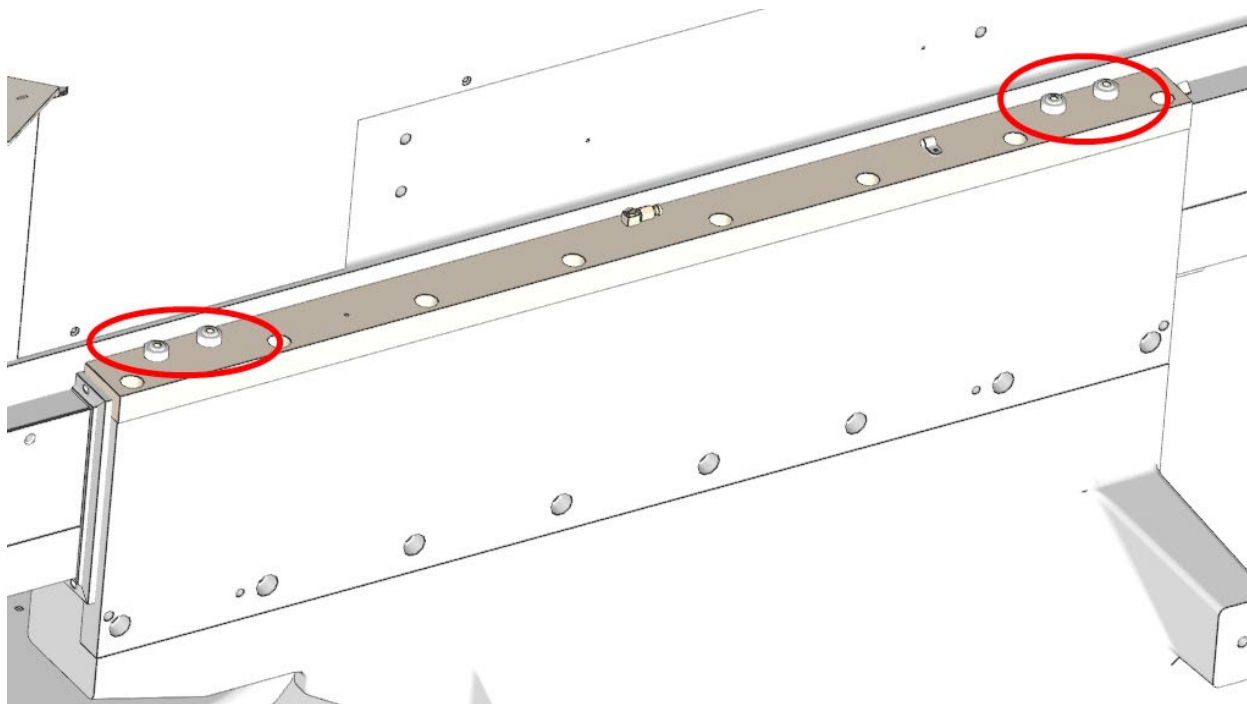

Adjustment Procedure

1. On the left side rail loosen the jam nuts.
2. Tighten the set screws until they bottom out and can't be turned further.
3. Loosen each set screw $1/8$ turn.
4. Tighten jam nuts.
5. On both top rails loosen jam nuts.
6. Tighten the set screws until they bottom out and can't be turned further.
7. Loosen each set screw $5/8$ turn.
8. Tighten jam nuts.

Software Backlash Settings

The Screens depicted below are for setting Backlash compensation values only. DO NOT use any other information on these screens to change information on the machine.

Turn off “Overshoot Backlash Setup”

Go to Setup Software>Addins>Overshoot Backlash Setup

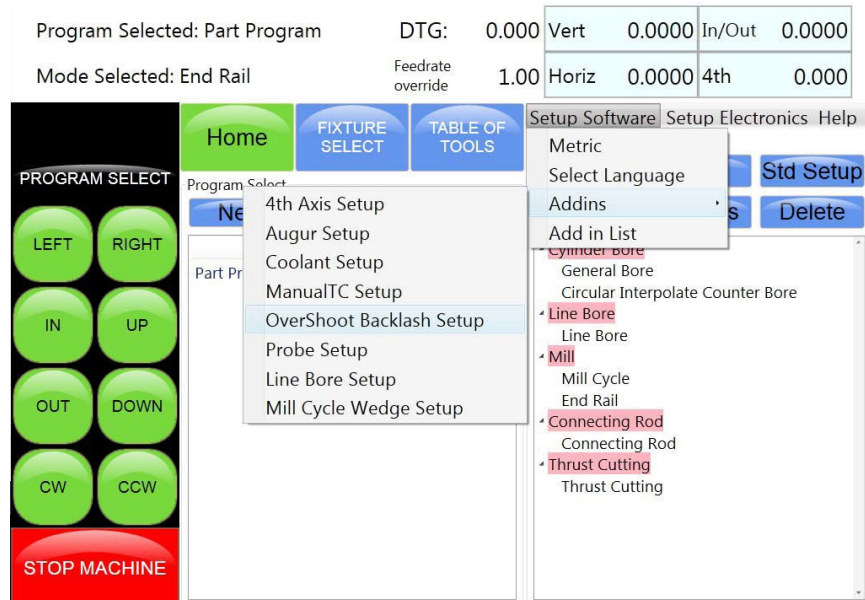

The Following screen will appear.

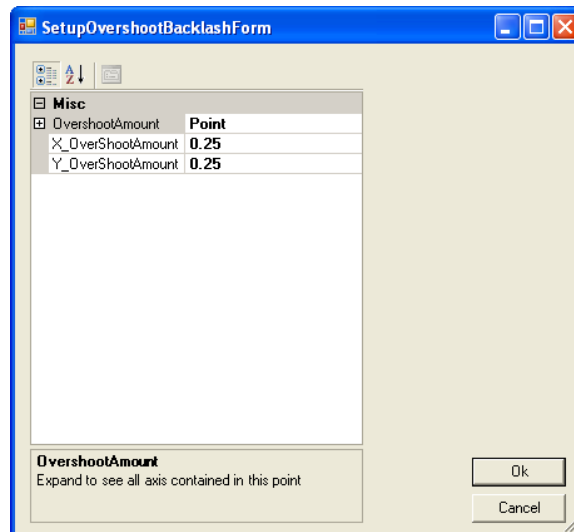

1. Record the existing X and Y “Overshoot Amount”. Generally, .250
2. Use the “On Screen Keyboard”, or plug in the full-size keyboard, and change the amounts to 0.00, and click on OK. Close the “Setup” screen.

3. Go to Setup Electronics>Control

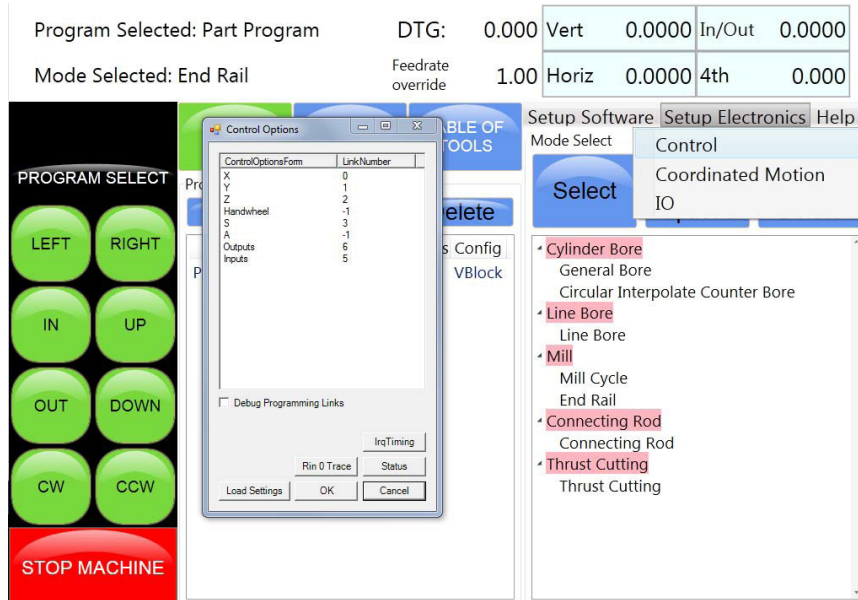

4. On the "Control Options" screen, double click the X to bring up the "X Options" screen.

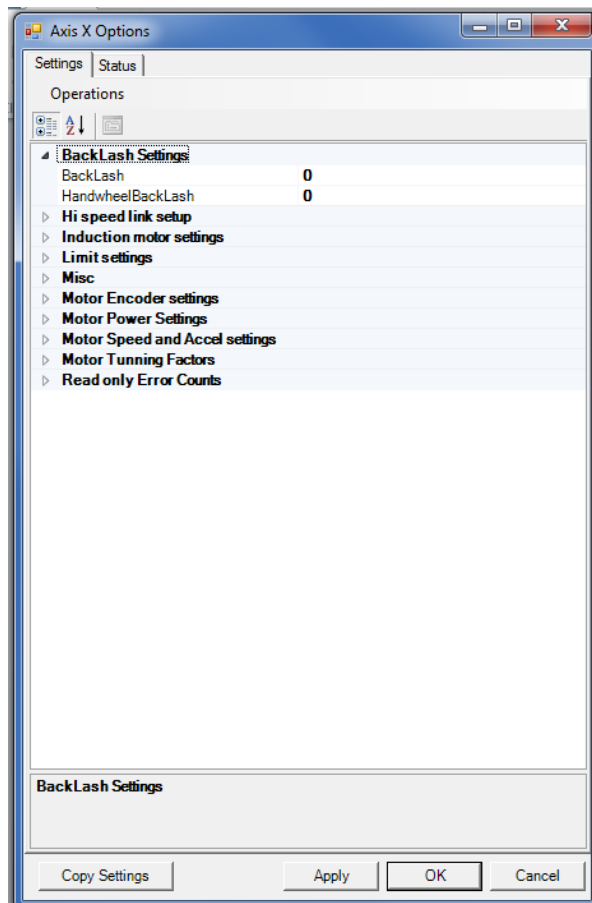

Minimize the screen

- Repeat step 5 for the Y and Z axis.
- Close the "Control Options" screen.

7. Select a program (block), then select any cylinder bore mode.

Program Selected: test	DTG: 0.000	Vert 0.0000	In/Out 0.0000
Mode Selected: General Bore	Feedrate override 1.00	Horiz 0.0000	4th 0.000

Set Zeros		Vertical Stops	Locations			
PROGRAM SELECT LEFT RIGHT IN UP OUT DOWN CW CCW STOP MACHINE	Zeros	Actual Position	Handwheel			Move To
	VERTICAL	0.0000	.010	.001	.0001	MoveTo Tool #: -1
	HORIZONTAL	0.0000	.010	.001	.0001	MoveTo Set Active
	IN/OUT	0.0000	.010	.001	.0001	MoveTo
	SPINDLE	0.00	10x	Coarse	Fine	MoveTo Probe #: -1
Spindle Load 0.0%		Feed Rate 0.0020	MOVE TO ZEROS			Set Active
Spindle RPM 400		PROBE AUTO CENTER	CW INDEX			CCW INDEX
			START SPINDLE			

Notes:

***The photos shown are demonstrating the X axis (horizontal) backlash adjustment. The Y and Z axes are adjusted following the same steps.

***The direction of machine travel to put the initial load on the dial indicator, are as follows: X (horizontal), from the right toward the left. Y (in/out), from back toward the front. Z (vertical) from top toward the bottom.

A Dial Indicator with 1.0" to 1.5" of travel should be used for several reasons.



If the axis is overshooting or coming to position slowly you will be able to see it with a dial indicator. With the digital indicator you will only see the end position. The Magnascale indicator should be used to dial or tram in. The automatic moves of the machine can "Shock" the sensitive plunger of the Magnascale.

- Attach the magnetic base and dial indicator to a stationary stand, parallel, or engine block fixed to the machine bed.

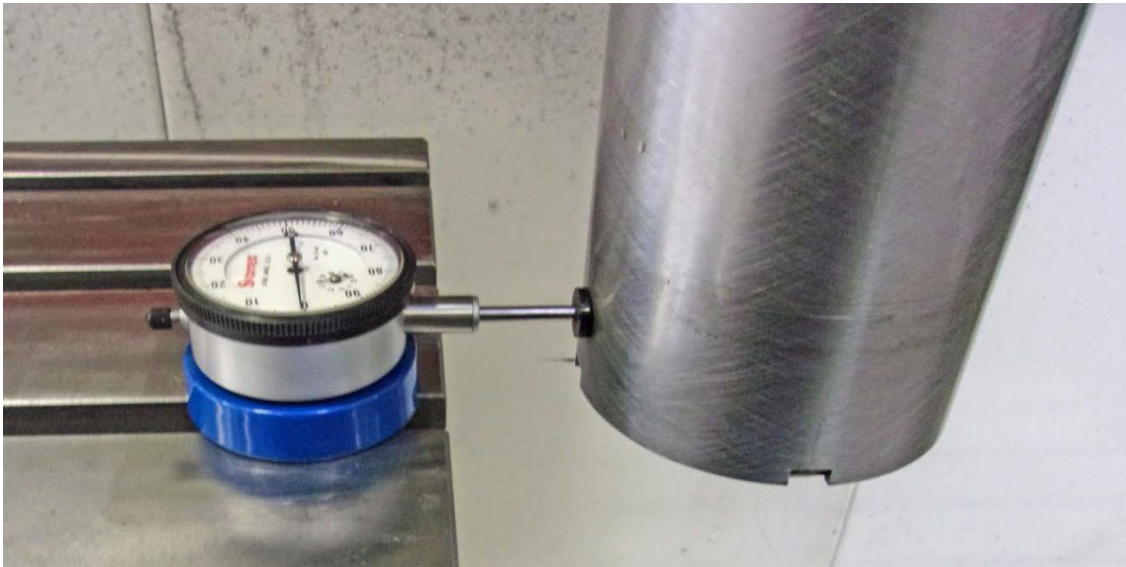

- Bring the spindle of the machine in position to put a slight load on the Plunger, about .020".
- Set "Vertical, Horizontal, In/Out" zero.

Program Selected: test 0.000 Vert 0.0000 In/Out 0.0000

Mode Selected: General Bore 1.00 Horiz 0.0000 4th 0.000

Set Zeros		Vertical Stops	Locations		
Zero	Actual Position	Handwheel		Move To	
VERTICAL	0.0000	.010	.001	.0001	MoveTo
HORIZONTAL	0.0000	.010	.001	.0001	MoveTo
IN/OUT	0.0000	.010	.001	.0001	MoveTo
SPINDLE	0.00	10x	Coarse	Fine	MoveTo

Tool #: -1
Set Active

Probe #: -1
Set Active

Spindle Load 0.0%

Feed Rate 0.0020

Spindle RPM 400

STOP MACHINE

PROBE AUTO CENTER

MOVE TO ZEROS

CW INDEX CCW INDEX

START SPINDLE

11. Set all vertical stops to “zero”

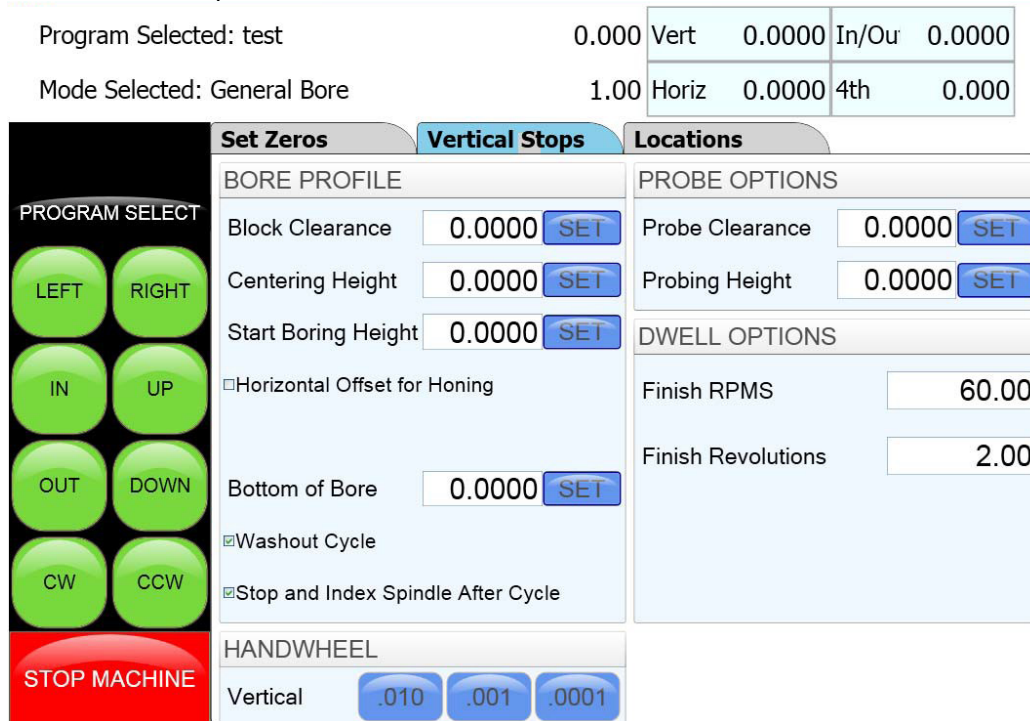

12. Move the machine spindle away from the Plunger a few inches and press “Move to”. Enter 0 for the value and press “Enter” for the axis being measured

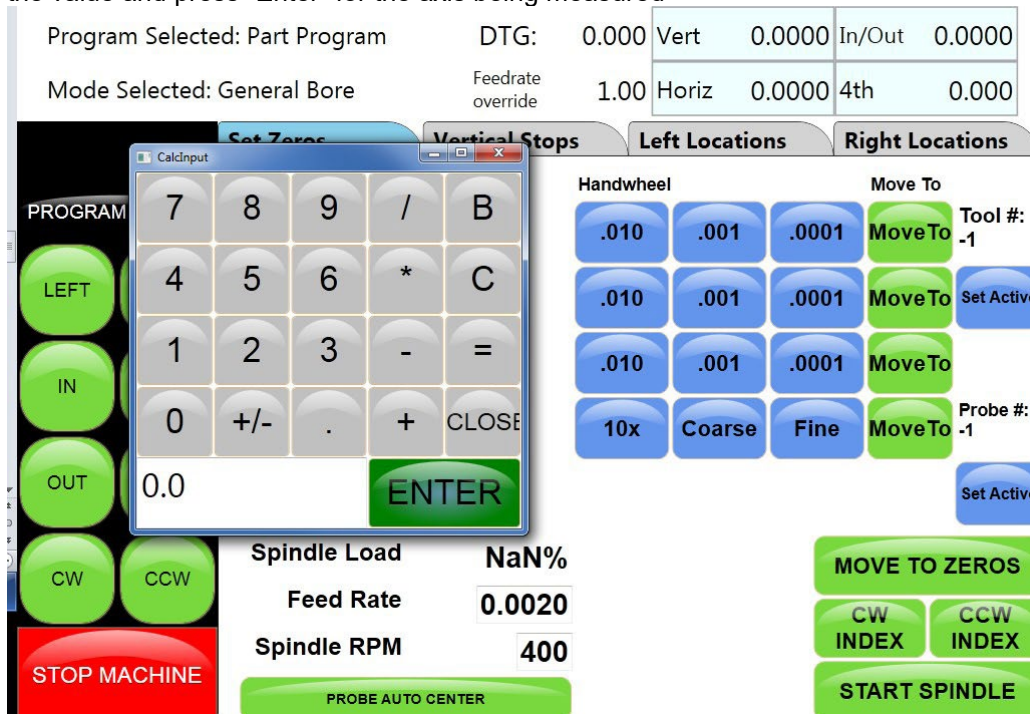

- 13. Repeat the movement to verify the machine will repeatedly position itself at zero.
- 14. Now use the “Move To” button and enter -0.200 to move the spindle in the opposite direction
- 15. Press “Move To” and enter 0 for the axis being measured

If the machine did not position itself to bring the digital readout to zero, a backlash compensation adjustment is needed.

16. To adjust the backlash compensation, maximize the “Axis X Options” screen. Go to “Backlash Settings” > “Backlash”

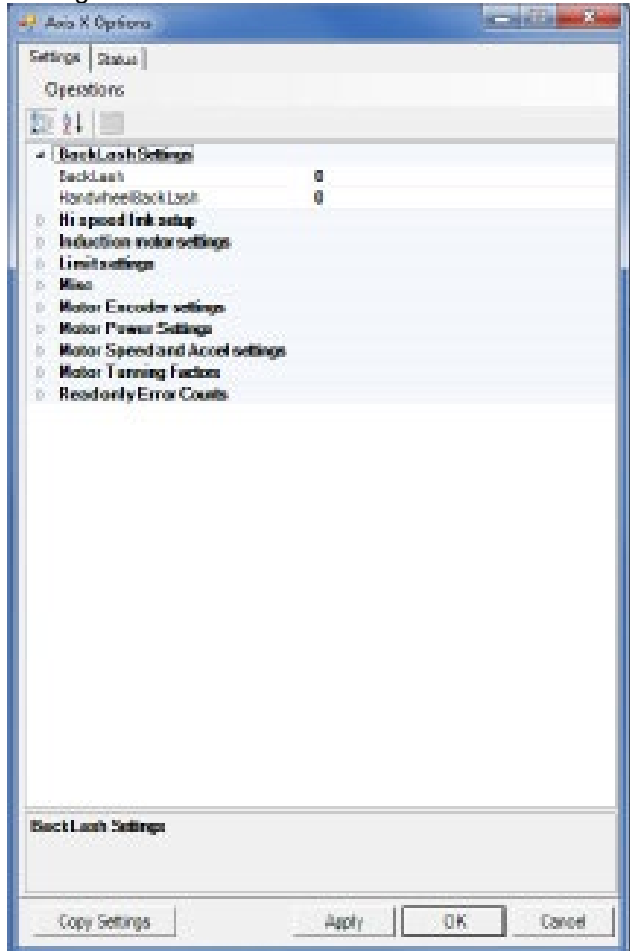

17. Use the on-screen keyboard, or plug in a keyboard, to enter the amount of correction in the Backlash area. Press “Apply” when you are done.
18. Repeat steps 13 through 17 and adjust as needed until the machine positions itself to zero on the digital read out from both directions

Handwheel Backlash is measured in a similar way to backlash but the axes are moved using the Handwheel, NOT the “Move To” buttons.

19. Set up the dial indicator as described in steps 8 and 9
20. Touch the .001” handwheel button and move the axis away. Turn the handwheel at a **constant speed** and move the axis back until the control panel displays zero. If the axis travels past zero, start again. Check that the dial indicator reads zero. If it does not, move away and back again until both the indicator and the control panel reads zero.
21. Now move the axis in the opposite direction and stop about 0.020” less than the total plunger travel before compressing the plunger all the way. Now move the axis back by turning the handwheel at a **constant speed** until the control panel reads zero. Check the reading on the dial indicator.

22. Use the on-screen keyboard or plug in a keyboard to enter the amount of correction in the Handwheel Backlash field. Press “Apply” when you are done.

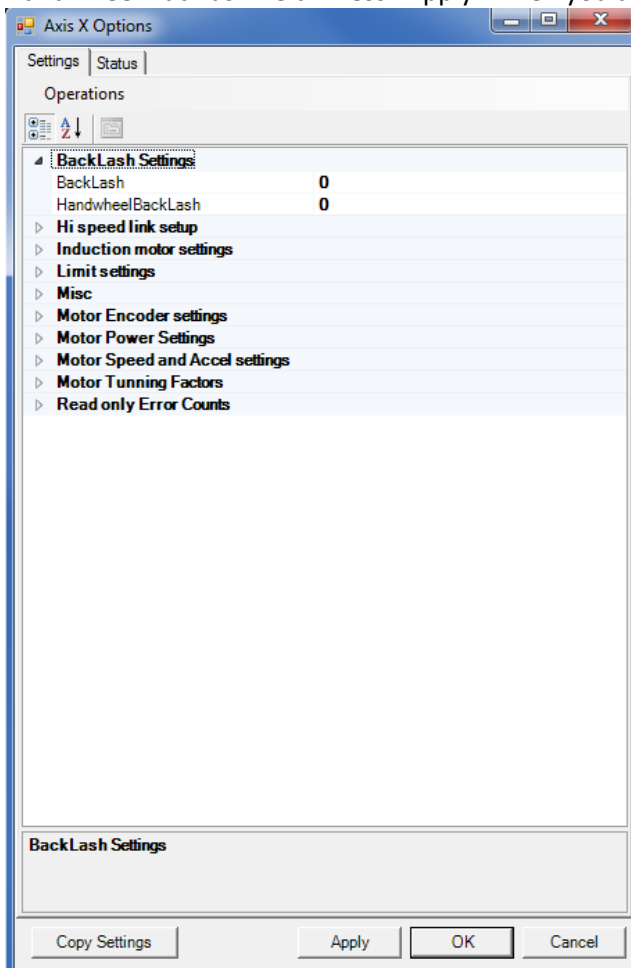

23. Follow steps 9 through 22 for the Y- and Z-Axis adjustments
24. When finished, re-enter the “Overshoot Backlash Amounts” as recorded in step 2 and click “OK” to close the window.

Mill Mode Tilt Adjustment

1. Position the Y-Axis in the middle of its travel. Using a 5/32" hex key, loosen the locking set screw through the access hole in the right-hand side guide rail



2. Put the machine in "Mill Cycle" mode, with the wedge turned off. Attach an indicator as shown in the following photo, and set it to zero



3. Using a 3/16" hex key, turn the adjustment screw CCW to increase or CW decrease the amount of mill tilt. After each adjustment, press the "Wedge On" button to check the amount. Set the lift amount to between 0.002 and 0.004" (0.05-0.10mm). Turn the wedge off to readjust.
4. When finished, tighten the locking set screw as shown in step 1

5. Repeat the procedure for the rear wedge.



6. After adjusting the rear wedge, re-check the front to make sure it did not change.

Replacing the Counterbalance Cylinder

1. Move the spindle to its full up position. Cut a piece of wood and place it under the spindle housing as shown below to prevent the spindle housing from dropping when air is removed from machine.

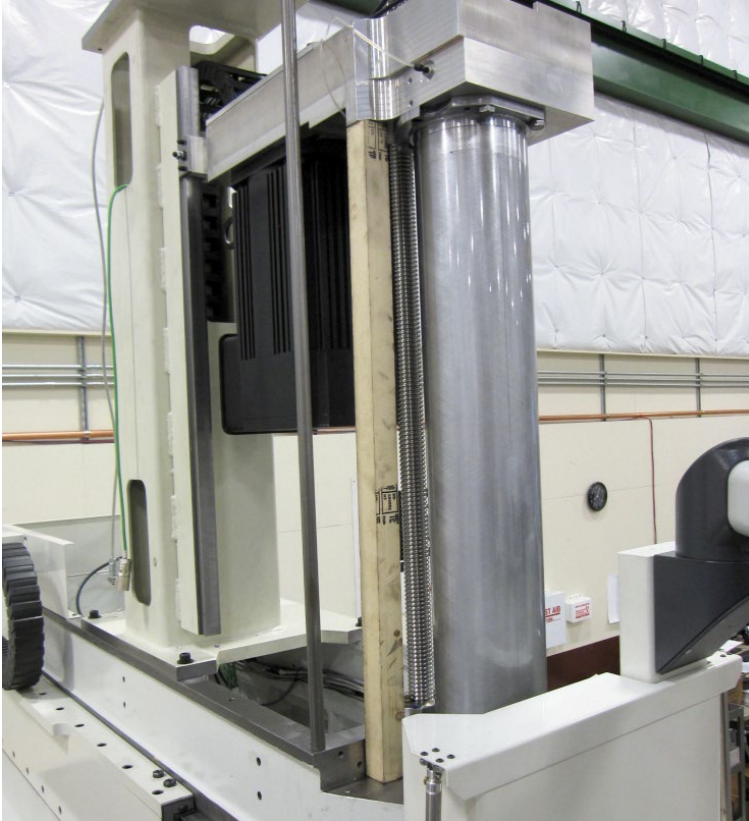

2. Shut down the machine at the electrical panel and lock out in accordance with safety regulations and or shop safety policy.
3. Unplug air from machine and remove the pop off valve to bleed air from the counterbalance cylinder.
4. Remove air line from fitting and cut off any zip ties that hold the line to the cylinder.
5. Remove pop off valve assembly for reuse on new cylinder.

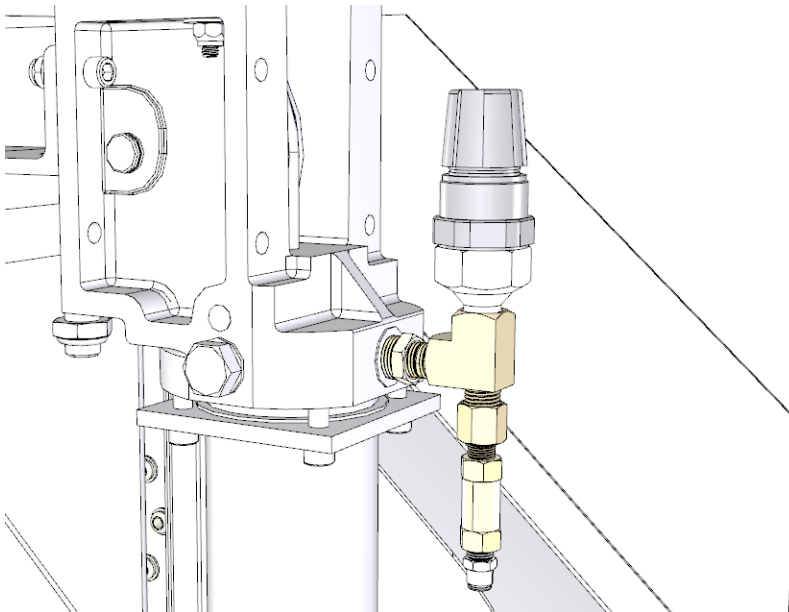

6. Remove the cable end from the top plate.

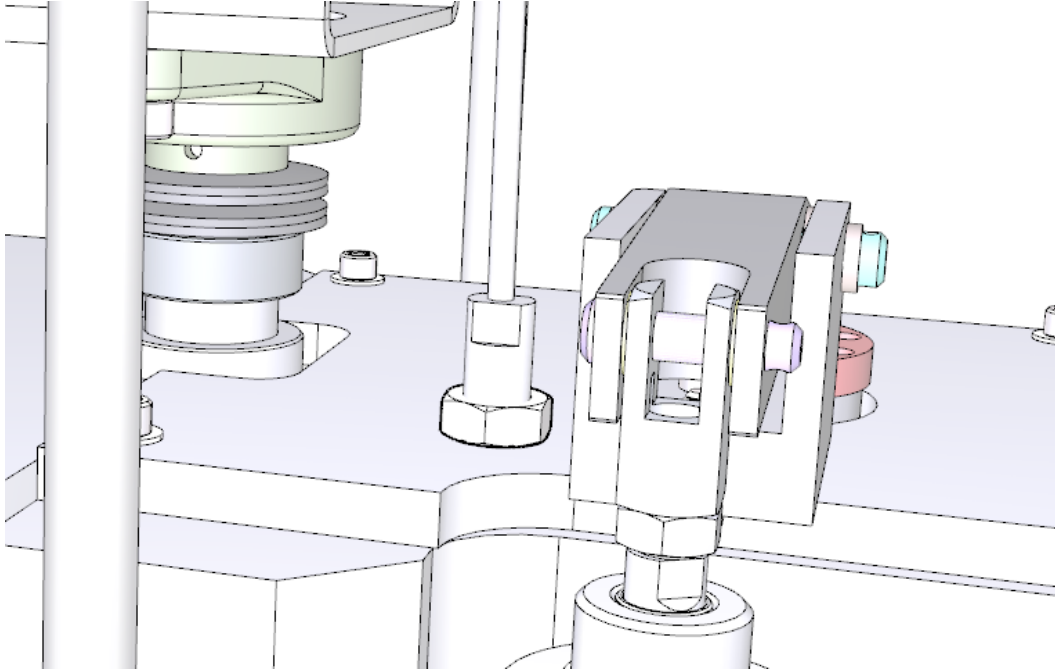

7. Remove the cable guide from the double pulley assembly.

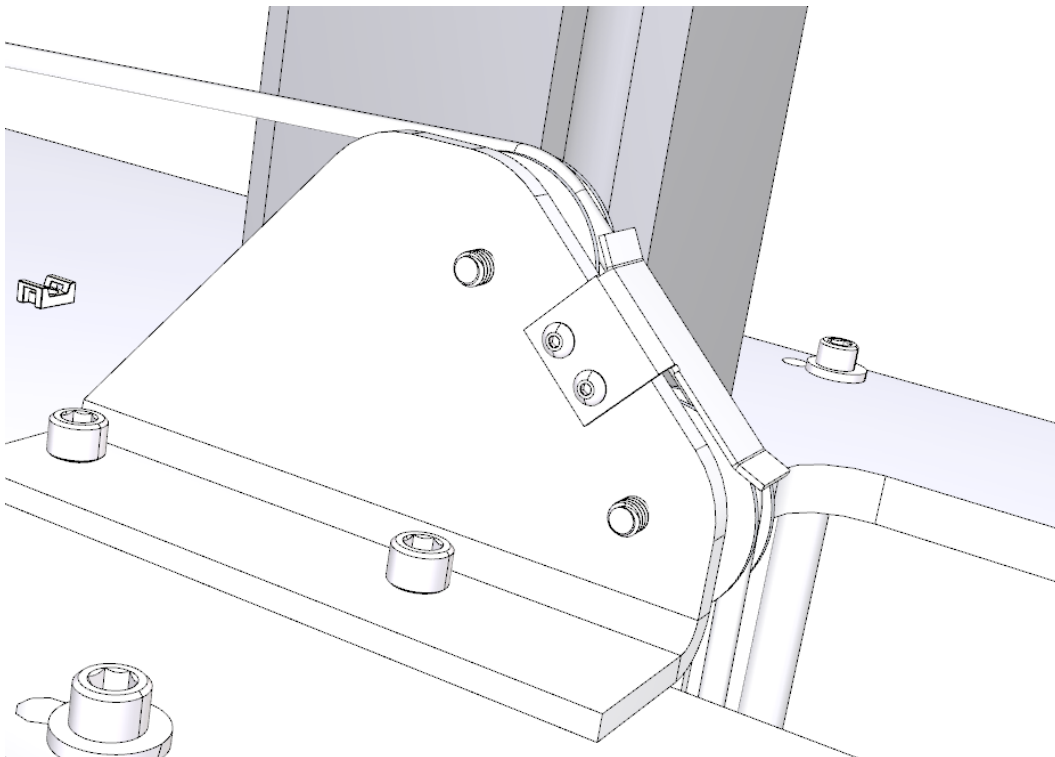

8. Remove the top cover from the cylinder and set aside
9. Unbolt the top of the cylinder from the bracket holding it to the top plate

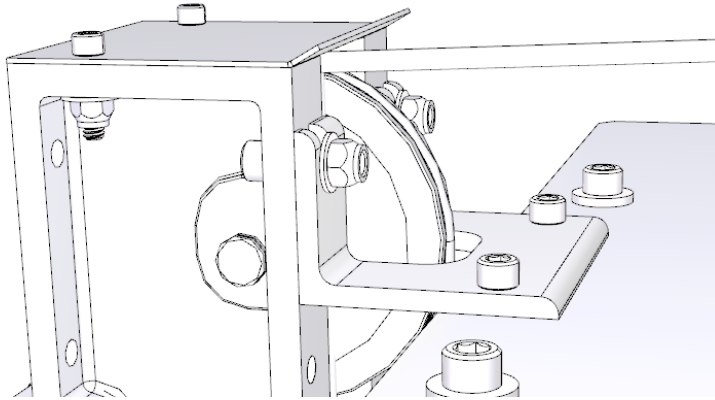

10. Remove the sheet metal covers at the back to access the counterbalance cylinder.

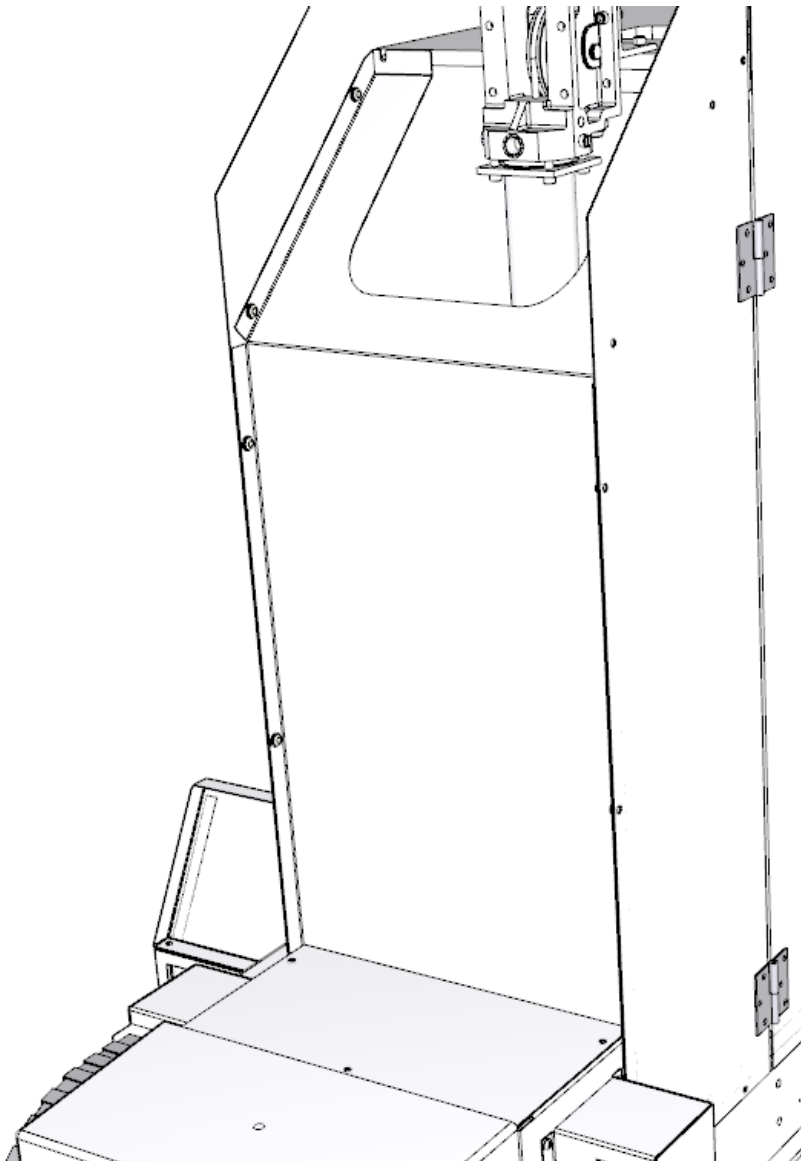

11. Unbolt the cylinder assembly from the tower base plate and install the new cylinder



12. Bolt top of cylinder to top plate bracket and reinstall top cover.
13. Install pop off valve assembly to the top of the cylinder and attach air line.
14. Replace the sheet metal covers.
15. Run the cable over the double pulley assembly and screw the end into the top plate.
16. Replace the cable guide on the double pulley assembly.
17. Reattach air to the machine.
18. Turn the power back on, run the spindle up, and remove piece of wood that supported the spindle housing.

Digital Micrometer Setting Instructions

Turn the thimble until the '0' line on the thimble lines up with the vertical line nearest the spindle lock ring.



Determine which cutter head bore range the micrometer is going to be used on. (example; 2.9 – 6.0)
We want to initially set the micrometer to the minimum bore diameter of this cutterhead.

NOTE: MICROMETER CAN NOT BE PROGRAMMED IF THE LETTERS INC APPEAR IN THE DISPLAY. To get rid of INC, quickly press the in/mm/ABS button.



To set or edit micrometer



Press and hold the set/on button and the + or – button at the same time. “Set” will flash in the display. This places the micrometer in edit mode. (CAUTION: use a pencil tip or something similar to gently push the small round buttons - they are quite small and a bit delicate.)

Press and hold the + or – buttons to change the display number to the minimum bore diameter determined earlier (example; 2.9). Caution: Pushing the + or – buttons and holding in place will cause the numbers to scroll automatically. The numbers will count slowly at first and once 0.010” has been counted off the scrolling speed will pick dramatically.

After you have reached the desired number in the display, press the set/on button twice quickly to exit the edit mode. “Set” should no longer be flashing in the display. The micrometer is now ready for use.

CAUTION: AFTER MICROMETER SET-UP IS COMPLETE, DO NOT PUSH SET/ON BUTTON AGAIN. PUSHING THE SET/ON BUTTON DURING USE WILL RETURN THE DISPLAY TO THE ORIGINAL MINIMUM BORE DIAMETER. THE ONLY TIME YOU SHOULD USE THE SET/ON BUTTON AGAIN IS TO- A. To shut micrometer off at which time you push and hold the button or B. to turn micrometer display back on at which time you push button one time. The display will then show the last reading before micrometer was shut off.

CAUTION: DO NOT BACK THE THIMBLE ALL THE WAY OUT TO THE END OF IT’S TRAVEL. ONCE THE THIMBLE IS BACKED ALL THE WAY OUT, IT WILL NO LONGER ROTATE PROPERLY AND THE DIGITAL HEAD WILL NEED TO BE REPLACED.

Micrometer is calibrated in inch mode. If metric is desired, press and hold in/mm/ABS button until mode changes to metric (approximately 3-4 seconds). A quick press of the in/mm/ABS button will put micrometer in ABS mode: 0.000, with another quick press returning it to initial setting.

Set up the cutter head and bore a set up hole. Measure the bore accurately. Set the digital display to this bore dimension and then -

Loosen the set screw holding the large diameter anvil. Slide the anvil back out of the way.



Place the tool holder used to bore the hole into the micrometer frame. Slide the location nub on the back of the tool holder gently up against the end of the digital micrometer shaft.



Slide the large diameter anvil up until it touches the end of the cutting tip of the tool holder. Tighten the set screw.



Back the digital micrometer shaft off, then bring it up to touch the tool holder and recheck that the numbers in the display are the same as the numbers previously shown.



The micrometer is now set up for use with this cutter head.

Note: this procedure must be repeated to set the micrometer to a different cutter head. The micrometer can only be set to one cutter head at a time.

To shut off micrometer press and hold set/on button until screen goes blank or let micrometer set until display disappears.

With initial setting of micrometer it is recommended that you use the procedure detailed below in the event you think you have size problems.



Procedure:

The short vertical lines that cross the horizontal scale on the micrometer sleeve are reference marks. Set the zero on the micrometer thimble even with the first vertical line and note the size shown in the digital display. Record this size for future reference. Now follow the same procedure for each line and record the sizes. At any time you feel your micrometer is reading incorrectly, you can quickly refer to the recorded size of the line closest to the range you are using and check that the micrometer is still accurate.

Probe “On-Center” Adjustment

This covers setup and calibration of the probe, so it will accurately position your machine.

- Verify that the four adjusting screws and two locking screws are installed in the probe tool holder.
- Assemble probe on either CAT 40 Shank or Rottler Taper
- With the machine breaker that supplies power to the probe receiver turned off.
- Install batteries in the probe WITH stylus deflected.

Probe LED check will run.

- Release stylus after battery check this will put you in edit mode.
- First will be Switch off method, you want this at **purple, purple, yellow** (Radio On). If it is not, deflect and release stylus quickly to change the mode.
- Hold the stylus deflected until the colors change to move to the next setting.
- You should be at Switch Off method; it should be **red, red, yellow** (134 seconds). If it is not, deflect and release stylus quickly to change the mode.
- Hold the stylus deflected until the colors change to move to the next setting.
- You should be at Enhanced trigger filter; it should be **green, green, green** (on). If it is not, deflect and release stylus quickly to change the mode.
- Hold the stylus deflected until the colors change again to move to the next setting.
- You should be at Acquisition mode, **light blue, light blue, light blue**.
- Turn on machine and quickly deflect and release the stylus. This must be done within 10 seconds of turning on the power breaker to the probe. If you are watching the RMI-Q (located ON the machine) you will see the right light turn **red, yellow, red, yellow, red, yellow** is shows the partnership has been acquired.
- Go into the software and do a probe auto center and hit start probe to verify that it works correctly.

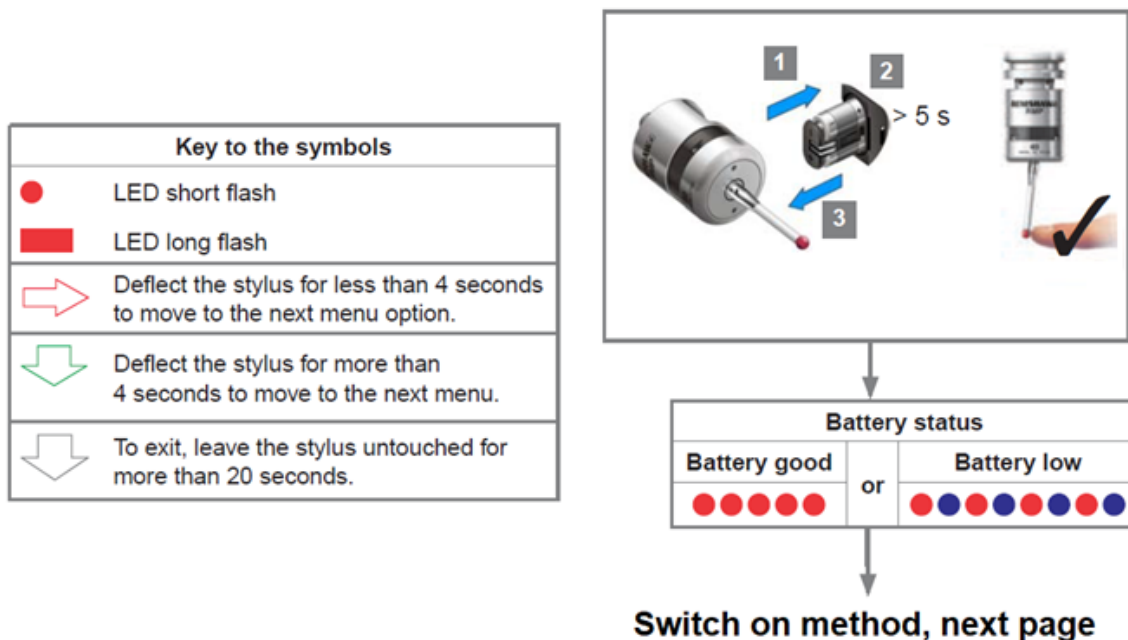

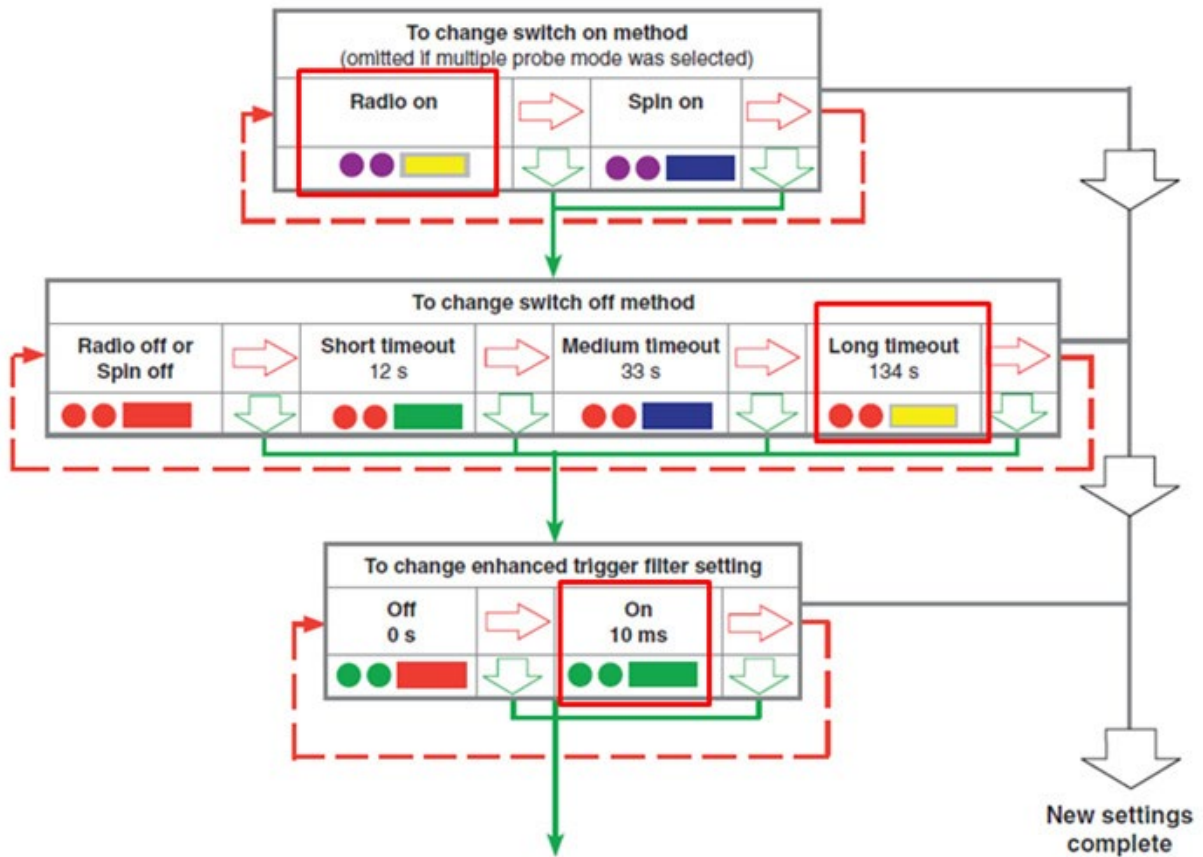

Changing the probe settings (continued)

Note: After the RMI has been acquired, the RMP40 will only show Acquisition mode off.

See RMP40 - RMI partnership.

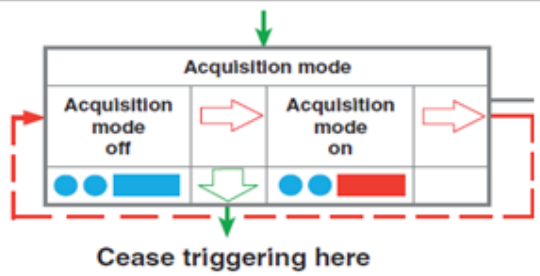

If the Probe does not turn off after 137 seconds you will need to make sure that the RMI-Q switches are shown in the following positions:

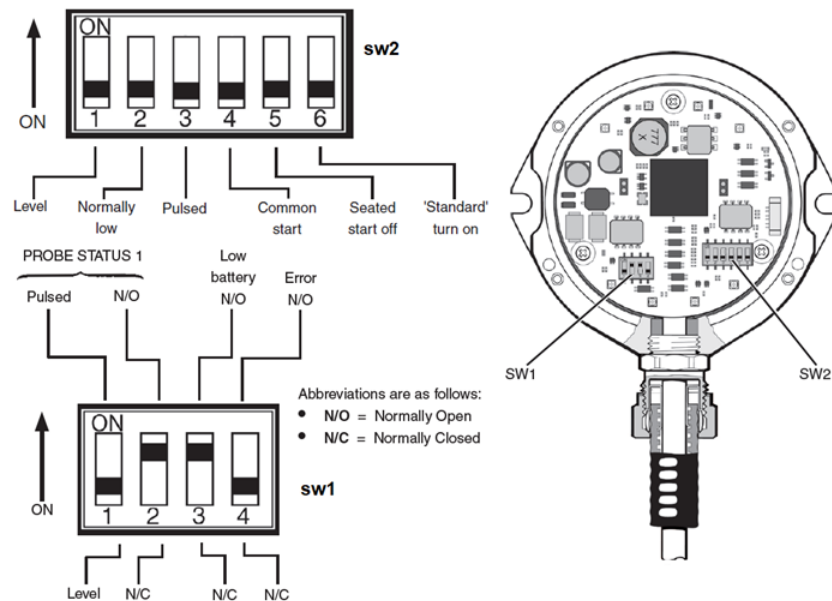

During normal use, the difference between the touch position and the reported position does not change, but it is important that the probe is calibrated in the following circumstances:

- when a probe system is to be used for the first time
- when a new stylus is fitted to the probe
- when it is suspected that the stylus has become distorted or that the probe has crashed
- at regular intervals to compensate for mechanical changes of your machine tool
- if repeatability of relocation of the probe shank is poor. In this case, the probe may need to be recalibrated each time it is selected.

It is good practice to set the tip of the stylus on center, because this reduces the effect of any variation in spindle and tool orientation. A small amount of run-out is acceptable, and can be compensated for as part of the normal calibration process.

- calibrating either in a bored hole of know size, a ring gauge, or on a datum sphere.

Mounting the probe on a shank

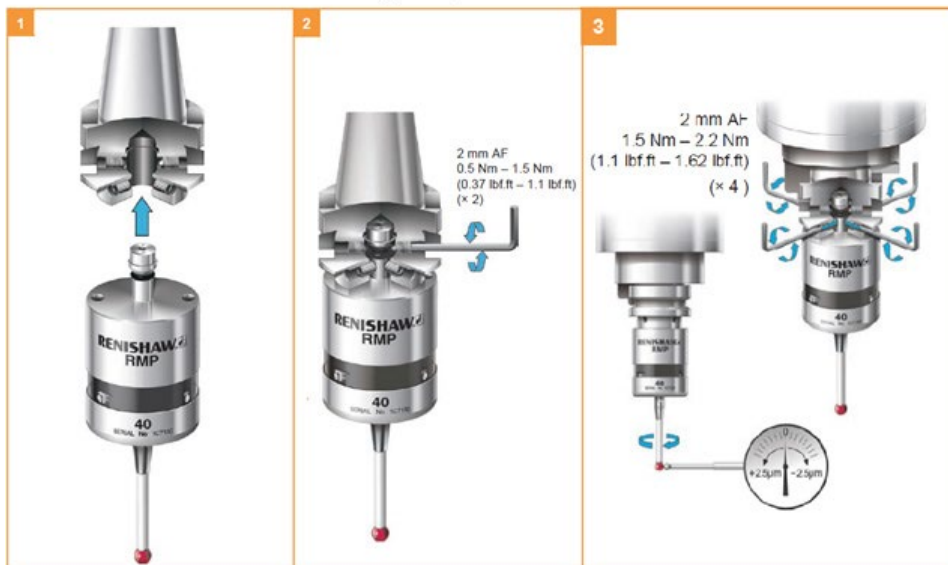

- Dial the probe stylus into center using a .0001" indicator to within .0005" the tighter tolerance you hold the more accurate the machine will be. You must use an indicator that takes very little pressure to get a reading. Excessive pressure on the stylus will deflect the probe and you will not be able to dial it in correctly.
- Go to the Main/Block Model screen and select the Table of Tools. You may only have a Default Tool #0 listed.
- Press Add Tool. This will bring up a dialog box. Change the name from default tool to probe style that you are installing i.e. 50mm stylus, 100mm stylus. Set the diameter to .2360" this is default probe tip on a 50mm, 100mm, and 17.5mm.
- Install a block, or parallels onto the machine and secure it solidly to the machine table.
- Place the Ring Gauge onto the top of the block, use Probe Auto Center to find center zero your X and Y axis here. Make sure you use a ring gauge or a hole of a known diameter. This will set the correct probe timing.
- Adjust the probed diameter by going to the IO under Setup Electronics and changing the Probe MS. You will need to increase or decrease the MS of the probe to achieve correct Probe Diameter.
- Repeat until the correct diameter is displayed.
- Probe Auto Center the ring gauge, without moving X or Y, remove the probe up in Z and Install the cutter head. Put a magnet base with the Last Word indicator on the cutter head and sweep the cylinder/ring gauge.
- The variation in X and Y Should be less than .0005.
- If not add compensation to ProbeOffset under > Setup Eletronics-Addins-ProbeSetup

Replacing the Motherboard Battery

If computer fails to boot up and you get a CMOS error message on the screen, then the battery on the computer motherboard has failed and needs to be replaced.

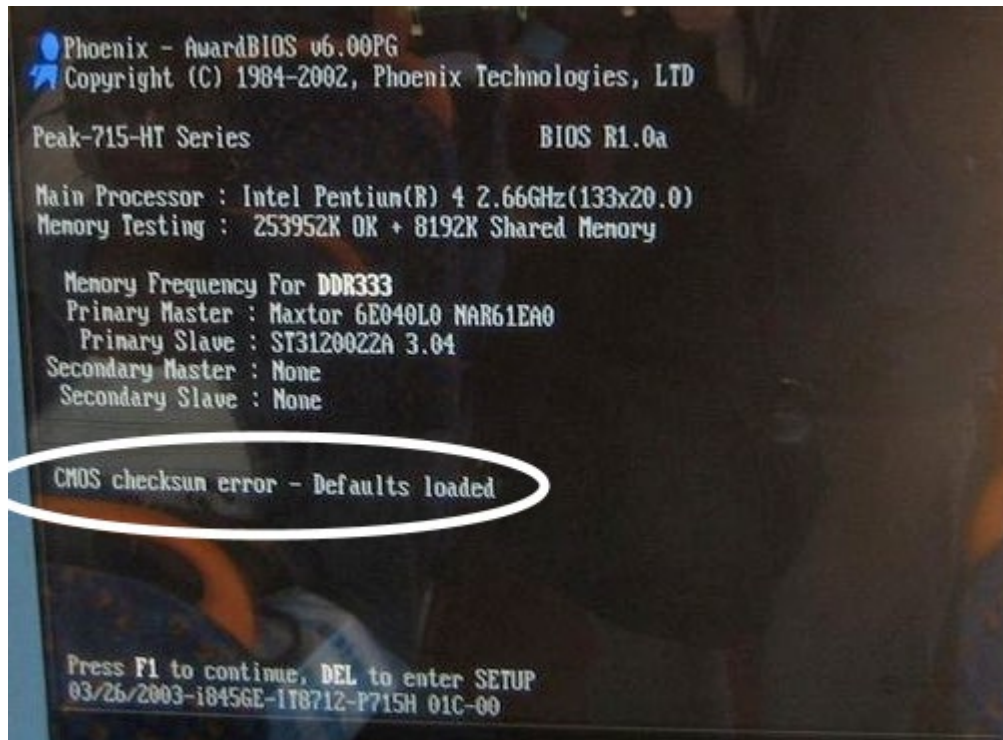

The following is the procedure for replacing the motherboard battery.

Turn off the power on the electrical enclosure and remove the enclosure cover.



Locate the computer and check to see that the power light is not on. If it is on turn off the power switch.

Note: On some machines it may be necessary to unbolt the computer from the enclosure in order to gain access to the cover screws.

Remove the 6 screws indicated by the arrows from the cover.

Remove the cover.



Locate the battery on the motherboard.



Push the battery retention clip away from the battery. When the clip is released the battery will pop up.



Remove the battery and place new battery in the battery holder.

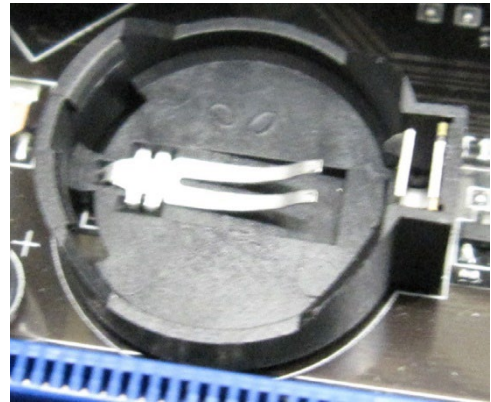

Using your fingertip, push down on the battery until the retention clip is in its lock position.



Replace computer cover and make sure that power switch on the computer is on.
Replace the enclosure cover and switch power back on.

Ballscrew Assembly References

Alignment Definitions for Angular Bearings and Belleville Washers

Bearing Alignment



VIEW OPEN END UP



VIEW CLOSED END UP

Belleville Washer Alignment

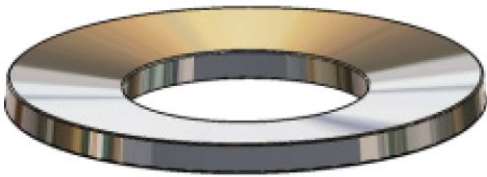

VIEW CUP UP



VIEW CUP DOWN

Z-Axis Lower Bearing and Belleville Washer Stack Arrangement

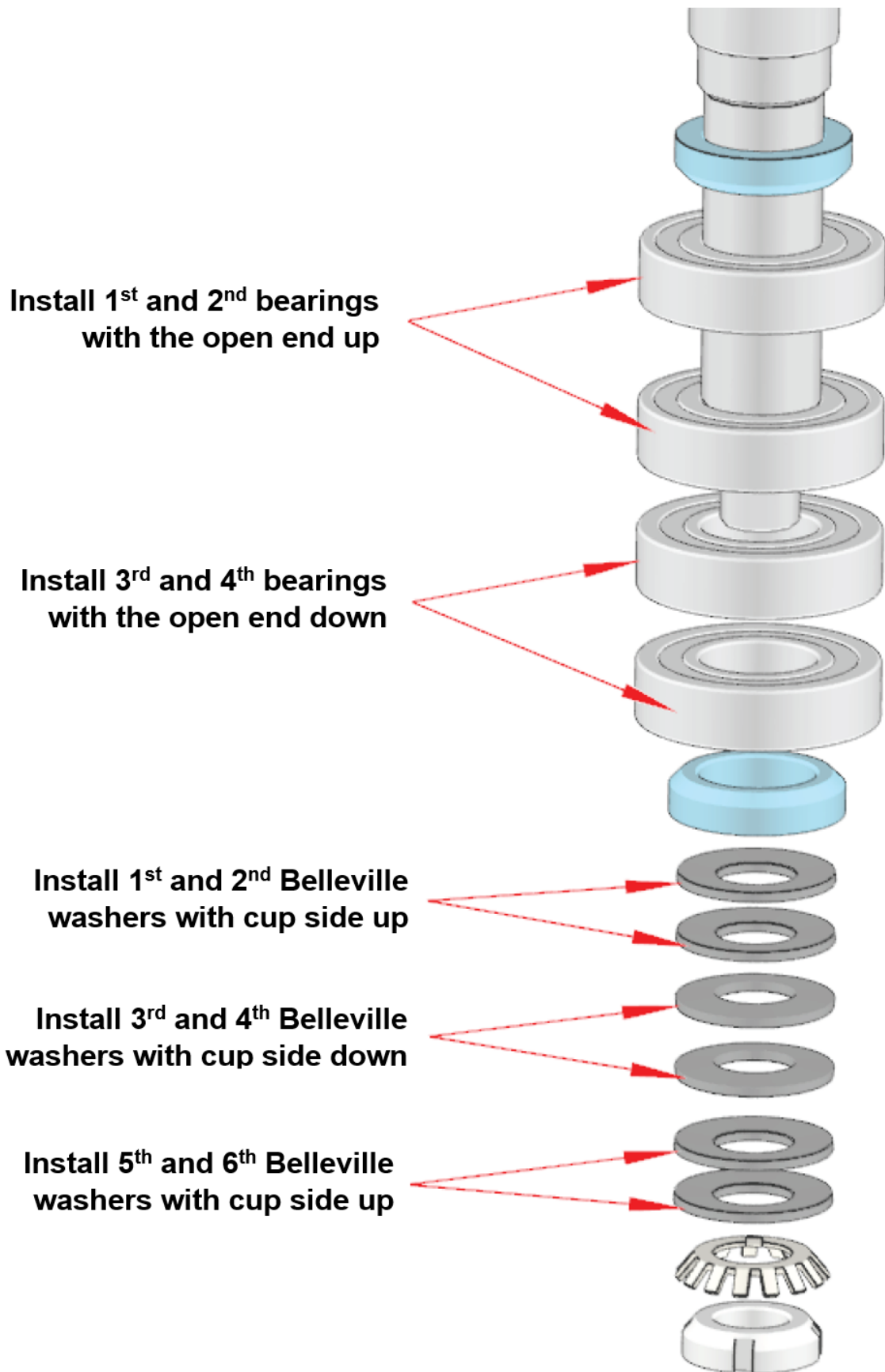

Z-Axis Lower Bearing and Belleville Washer Section View

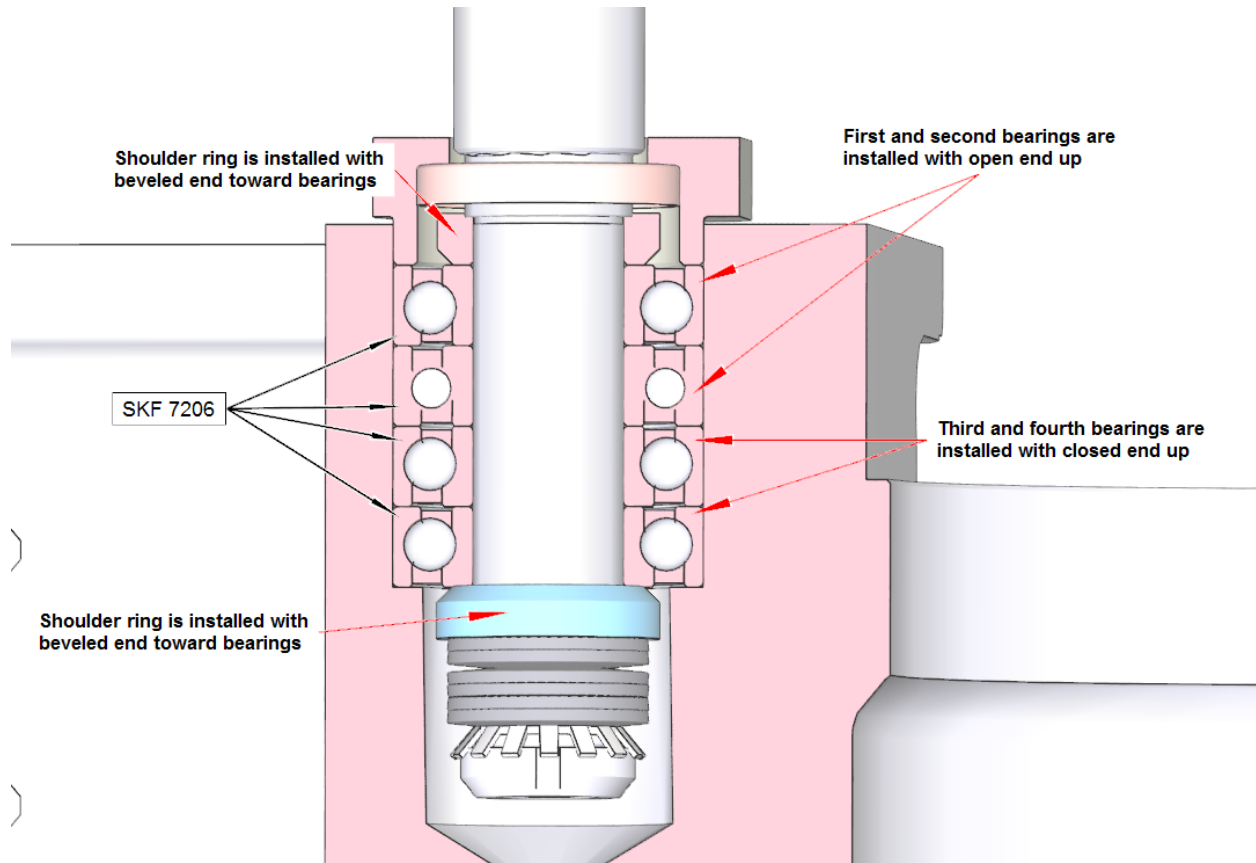

Z-Axis Upper Belleville Washer Stack Arrangement

Install 1st washer with cup side facing up, then alternate next 3 washers.

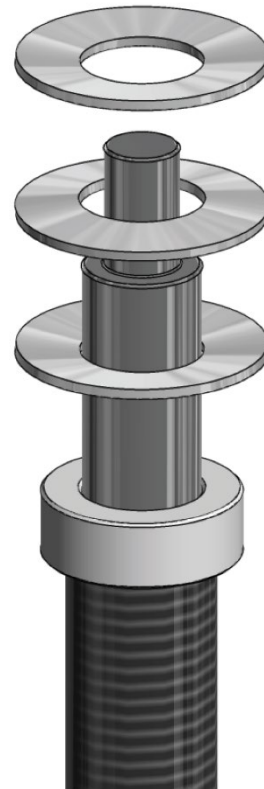

Z-Axis Upper Belleville Washer Section View

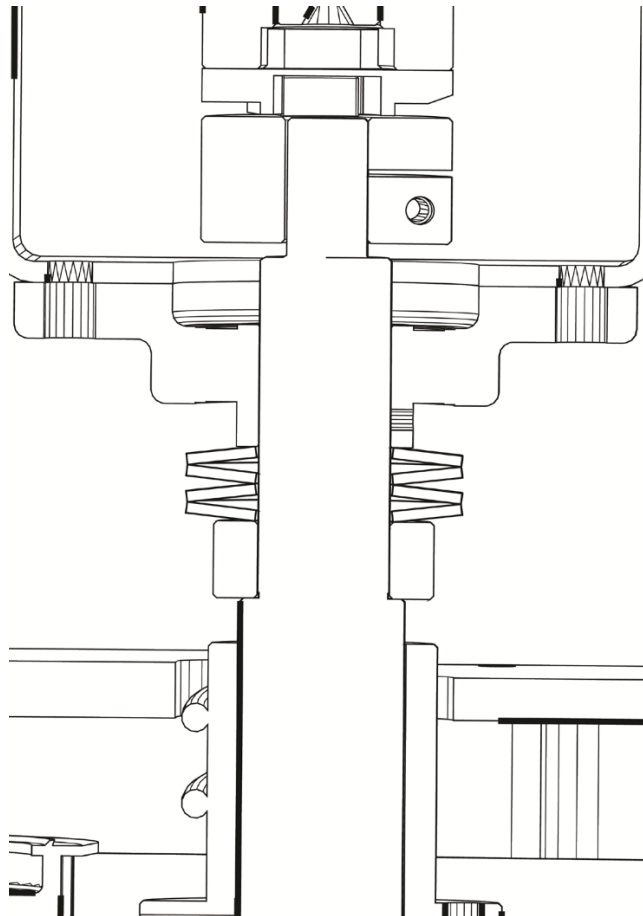

X-Axis Drive Side Bearing Arrangement

Install 1st and 2nd bearings with open side facing in. Install 3rd and 4th bearings with open end facing out.

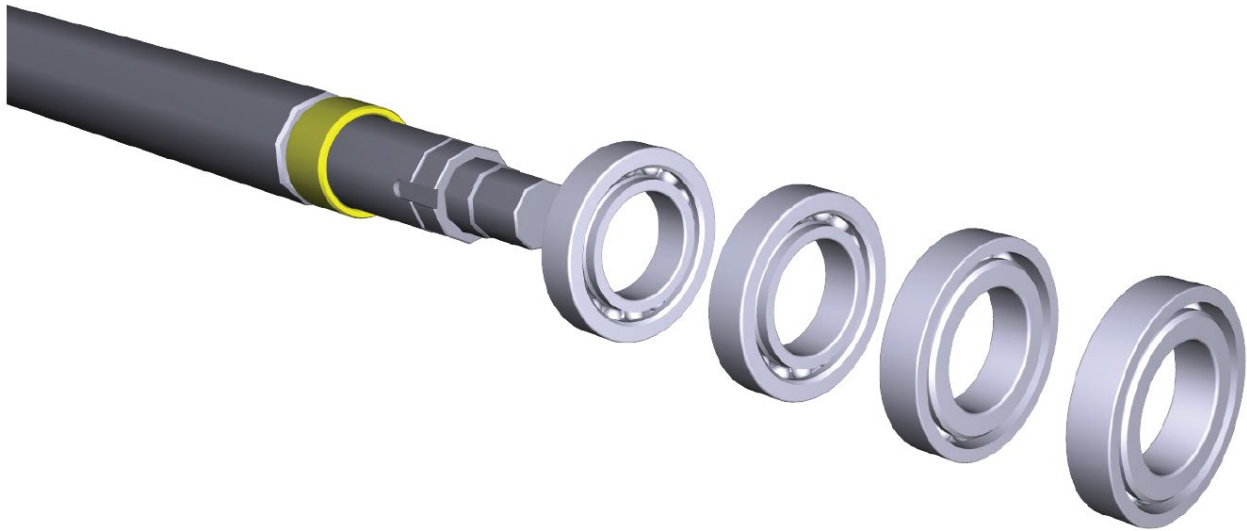
**X-Axis Drive Side Bearing Section View**

3rd and 4th bearings
are installed with the
open end facing out

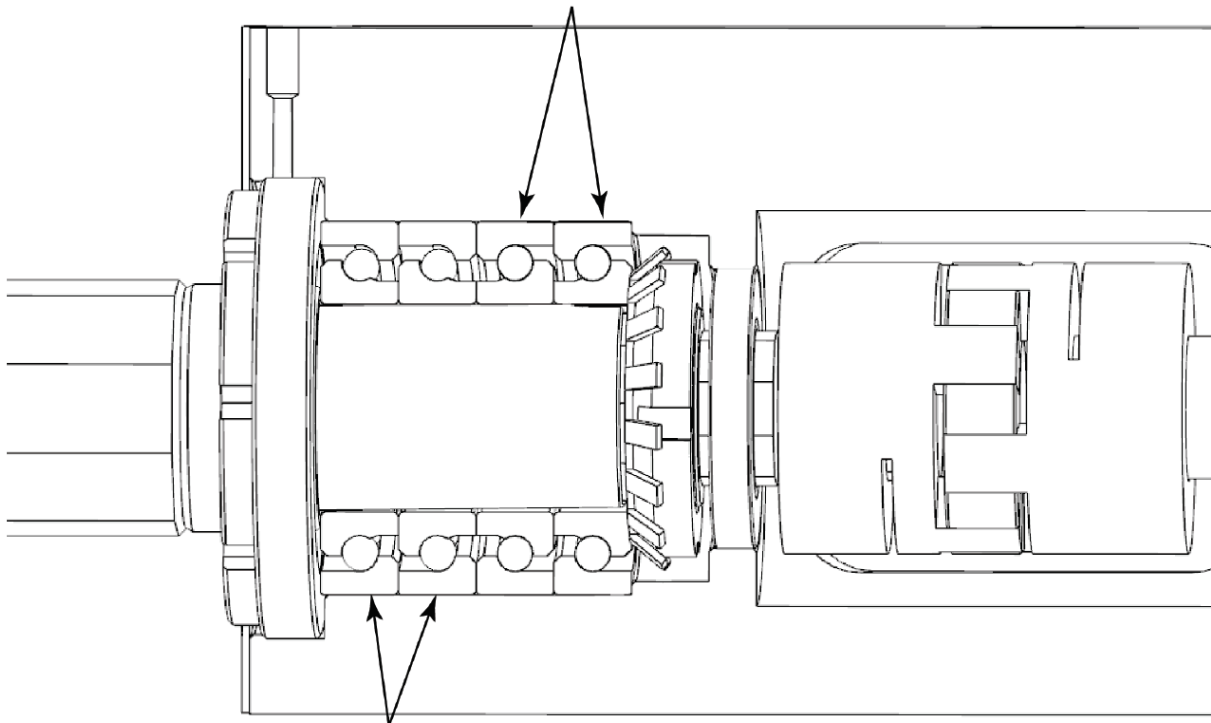

1st and 2nd bearings
are install with the open
end facing in

X-Axis Idle Side Bearing Arrangement

Install both bearings with open side facing out.

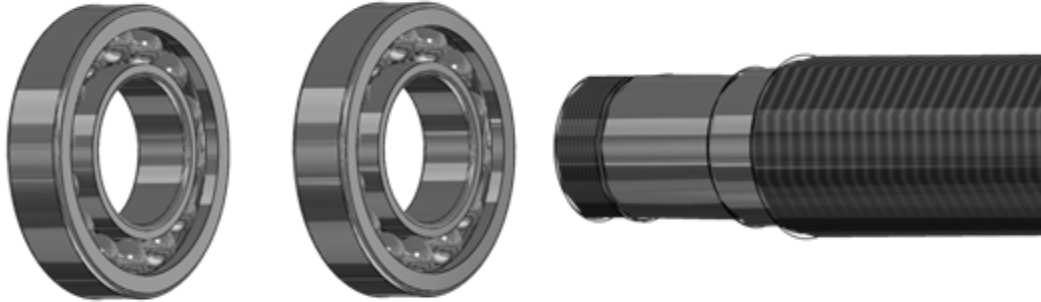

X-Axis Idle Side Bearing Section View

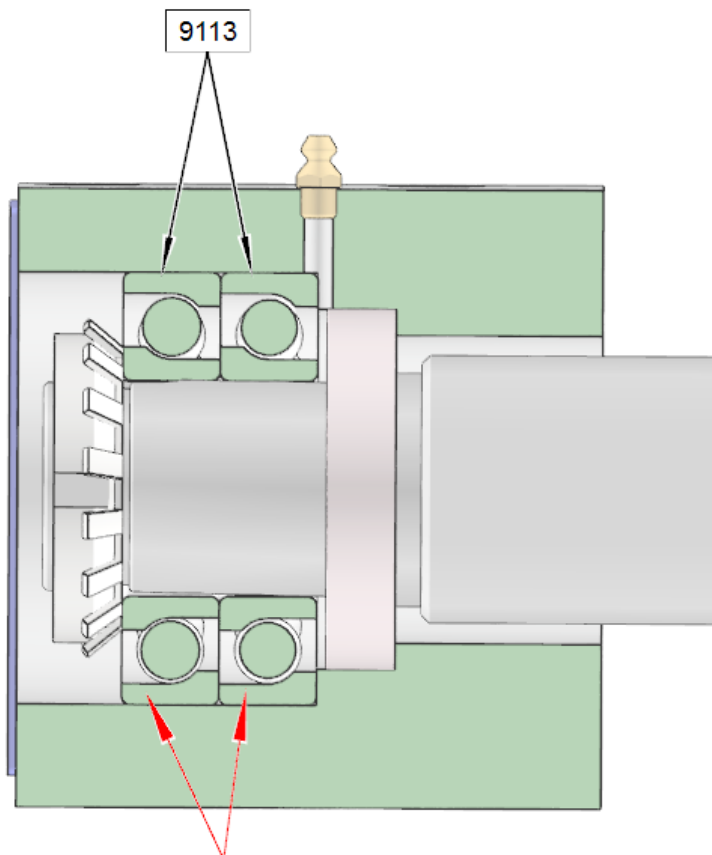

**Both bearings are installed
with open end facing out**

Y-Axis Bearing Arrangement

Install 1st bearing with open end toward ballscrew shoulder. Install 2nd and 3rd bearings with closed end toward 1st bearing.

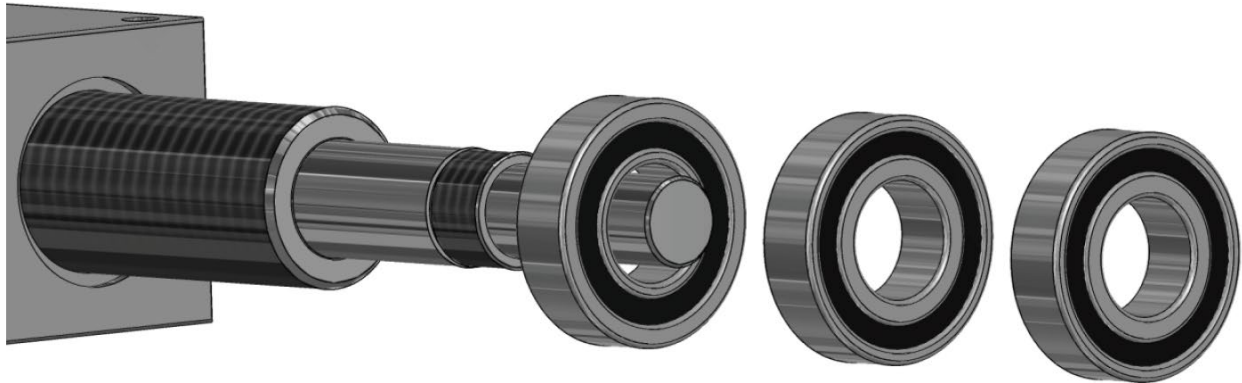

Y-Axis Bearing Section View

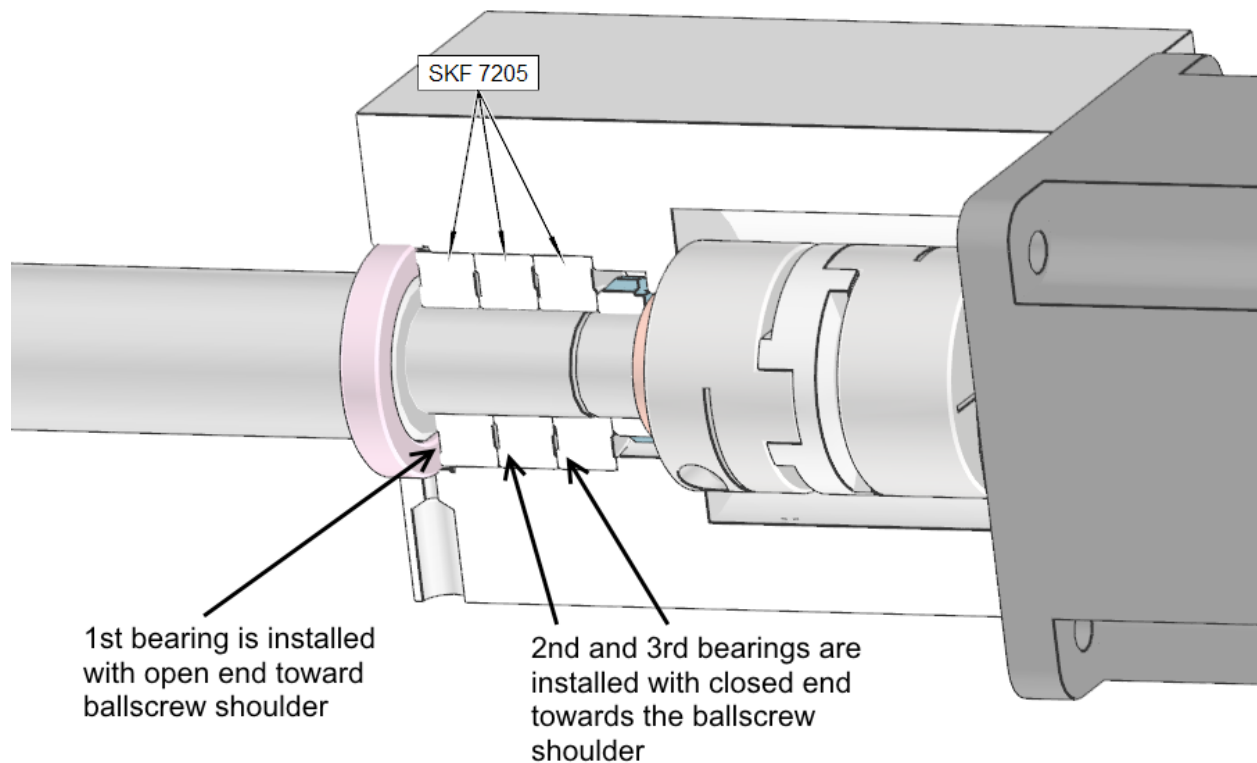

Inner Spindle Upper Belleville Arrangement

6113 Belleville washers are stacked in an alternating pattern with the bottom washer installed cup face up. (see illustration on right side)

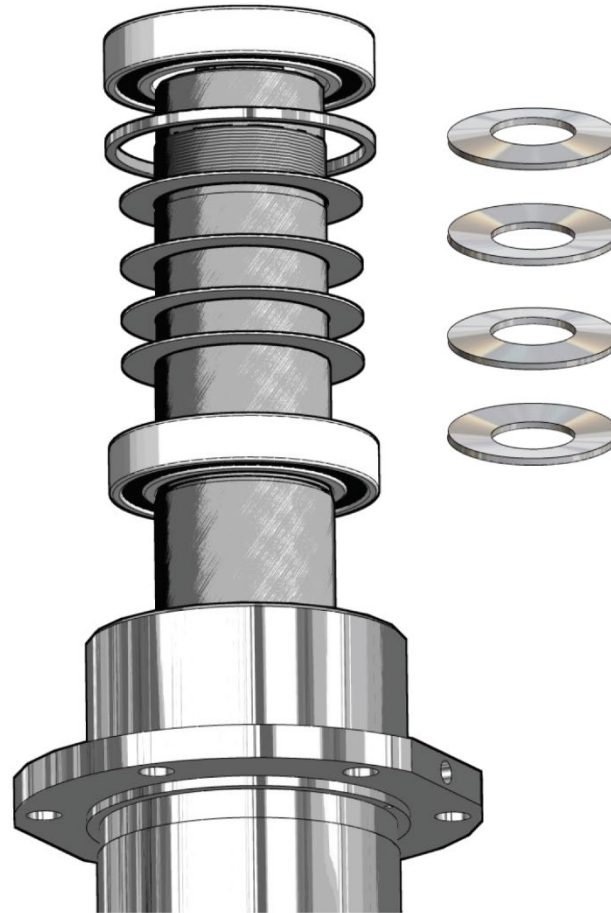

Inner Spindle Upper Section Belleville Washer Section View

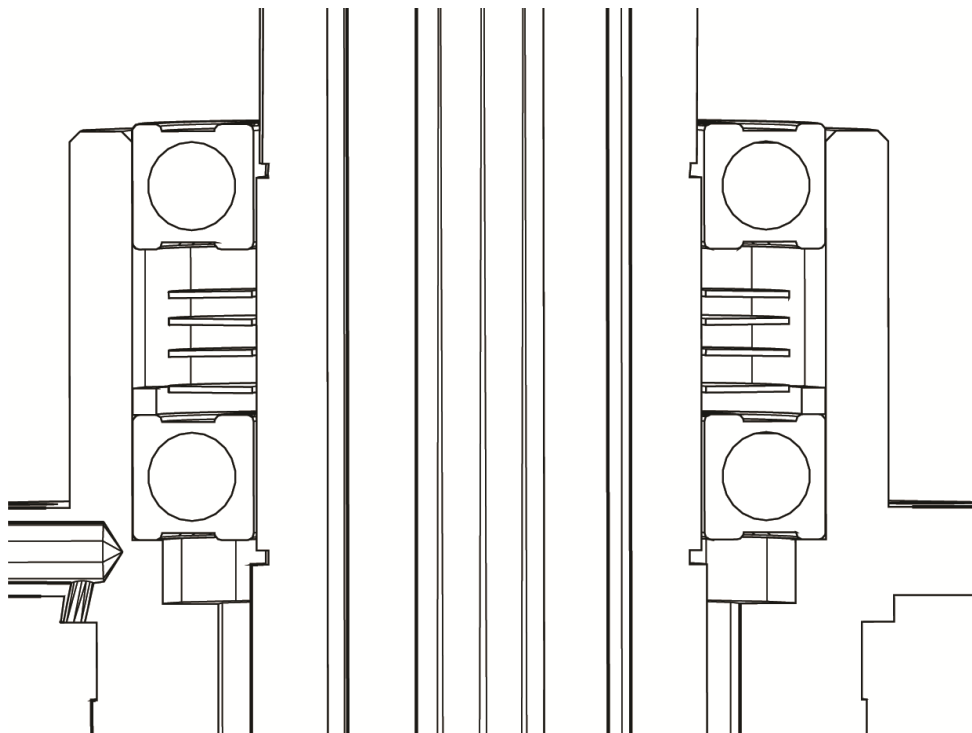

Inner Spindle Lower Section Bearing Arrangement

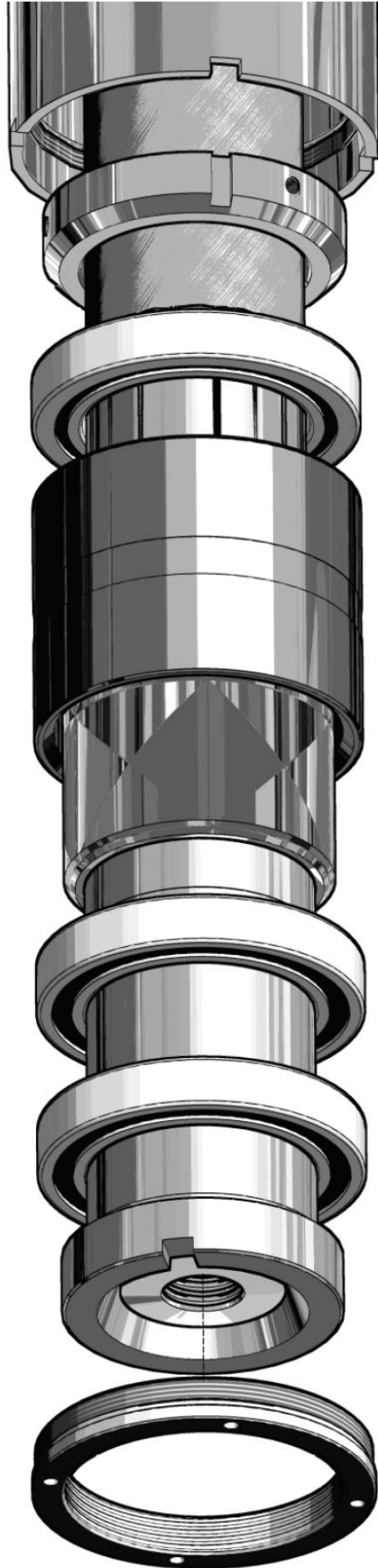

Install 3rd bearing with the closed side down.

Install inner and outer spacer assembly with beveled end facing up.

Install 2nd bearing with the open side down.

Install 1st bearing with the open side down.

Inner Spindle Lower Section Bearing Section View

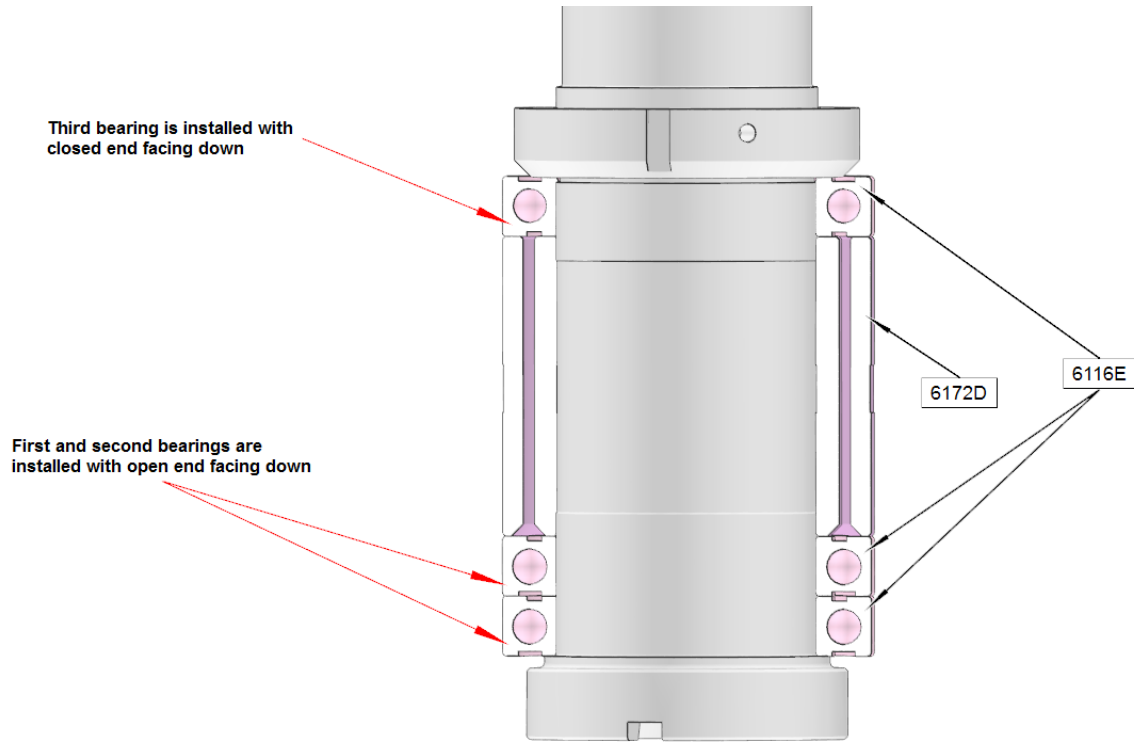

Wiring, Air and Oil Line Diagrams

Wiring Diagrams, Air Line Diagrams, Oil Line Diagrams

Please visit the service tab of our web page www.rottlermfg.com and Send a Service Request. Or contact the Rottler Factory Service at service@rottlermfg.com for assistance.

You may also call Rottler at 1-800-452-0534 or 1-253-872-7050

Please ensure you have the Machine Model and Serial Number available when contacting Rottler for Service

TROUBLESHOOTING

This is a list of common issues with EM103/4/5H machines. If the problem you are having is not listed, or if the suggested procedures do not correct it, please contact Rottler Service for further assistance.

Symptom	Possible Causes	Solution
<i>Mechanical:</i>		
Bore not vertical	Spindle not aligned	Spindle adjustment/Sweep
Excessive Oil Dripping	Oiler set too high	Adjust Oiler settings
Excessive Heat at Spindle	Not enough oil; Spindle Bearing Failure	Adjust Oiler settings; Replace bearings
Chatter during boring	Dull Insert	Replace Insert
	Dirt/Oil in the Cutterhead	Disassemble and clean the cutterhead
	Spindle out of adjustment	Check inner and outer spindle adjustments
	Counterbalance out of adjustment	Verify that the counterbalance is working and that the cable is not broken
Machine will not move in .001 or .0001 increments	Backlash out of adjustment	Check backlash bulletin 317
	Damage to components from machine crash	Inspect axis components for damage and replace if needed
Machine moves in jumps when using .001 or .0001 increment	Excessive backlash, unable to compensate	Check backlash, bulletin 317
	Tuning parameters incorrect	Contact Rottler Service
	Damage to components from machine crash	Inspect axis components for damage and replace if needed
Mill Mode Tilt: No lift	Low air pressure	Increase main machine regulator PSI
		Increase air source PSI
	Incorrect Control setting; Dwell time too short	Set dwell time for lift to 1500
	Incorrect Control setting; IO mismatch	Check that the IO number in the control is set according to the schematic
	Lift cylinder bolts loose	Check and tighten bolts
	Lift bolts set incorrectly	Set lift bolt jam nuts to 0.010-0.015"
	Top gibs set too tight	Loosen top gib set screws by one full turn
Incorrectly plumbed air lines	Verify plumbing connections with the schematic	
Mill Mode Tilt: Wedges not engaging correctly	Low air pressure	Set solenoid pressure to 30-40 PSI

	Incorrect Control setting; Dwell time too short	Set dwell time for lift to 1500
	Incorrect Control setting; IO mismatch	Check that the IO number in the control is set according to the schematic
	Wedges set incorrectly	Set wedge height to 0.002-0.004"
	Debris interfering with wedge operation	Lift spindle base and examine wedges for debris or damage

<i>Control System:</i>		
Following Error	<i>Mechanical:</i>	
	Binding due to wear; Loose Components due to wear	Check axis drive and wear components and replace if needed
	Damage due to a machine crash	Check components for damage and replace if needed
	<i>Electronic:</i>	
	Control system malfunction	Cycle E-Stop; Reboot system
	Bad Cable – Encoder	Test with a spare cable
	Bad Cable – USB	Test with a spare cable
	Bad Cable – Power	Test cable continuity with meter
	Bad Motor	Test amp with another motor
	Bad Amp	Test amp as described on page 3-#
	Bad Power Board	Test with a spare board
Touchscreen not responding where touched	Touchscreen not calibrated properly	Follow touchscreen alignment procedure.
Backlash over 0.015"	Ballscrew Wear	Inspect Ballscrew and nut for damage/wear; Excessive wear may require a replacement ballscrew

Touchscreen Alignment Procedure

1. Get to the Alignment screen.
 - a. If an Elo icon is available in the tool tray at the lower right side of the desktop, click it, then click Align.
 - b. Otherwise, go to the Windows Start Menu and find the Elo icon in the list of available programs, select it, then click Align
2. Touch and release the upper left target; the target should jump to the lower right.
3. Touch and release the lower right target; the target should jump to the upper right.
4. Touch and release the upper right target; a check screen should appear.
5. Touch and release the green check mark; the check screen should disappear.
6. The cursor should now jump to the point of touch.
7. If the Elo Control Panel is open, close it and the Windows Control Panel.

MACHINE PARTS

Contents

Machine Base Assembly	4-2
Machine Base Parts.....	4-7
Incoming Power Box Parts	4-7
Incoming Air Supply Parts.....	4-8
X-Axis Drive Parts	2-10
Rail Cover Parts.....	4-10
Column Assembly.....	4-11
Column Assembly Parts	4-11
Air Door Parts	4-20
Oiler Door Parts.....	4-21
Y-Axis Drive Parts	4-22
Mill Mode Tilt Wedge Parts	4-23
Mill Mode Lift Cylinder Parts.....	4-24
Gib Assembly Parts.....	4-25
Pendant Assembly Parts.....	4-27
Spindle Base Assembly.....	4-28
Spindle Base Parts	4-28
Z-Axis Drive Parts.....	4-39
Chip Shield Parts.....	4-40
Electrical Enclosure Parts	4-41
Spindle Housing Assembly Parts.....	4-44
Manual Tool Rack Assembly.....	4-46

Machine Base Assembly Parts

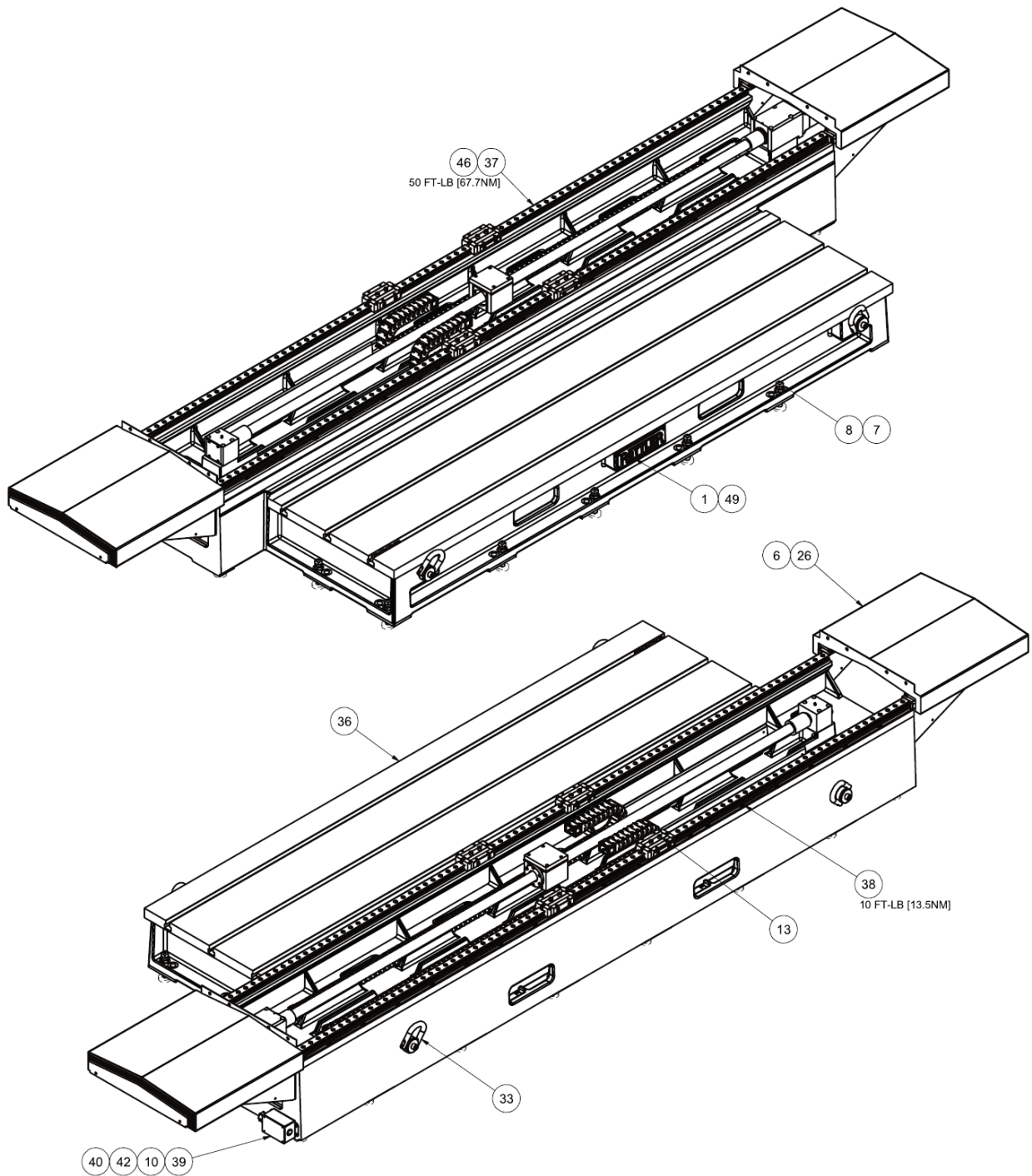

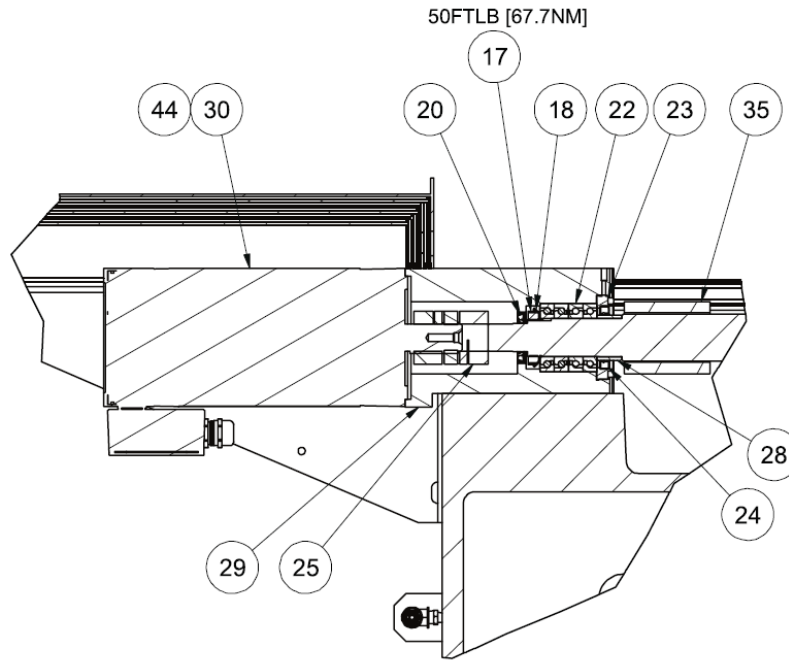

DETAIL B

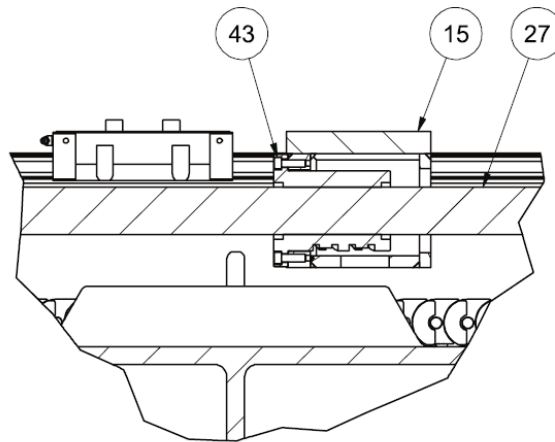

DETAIL C

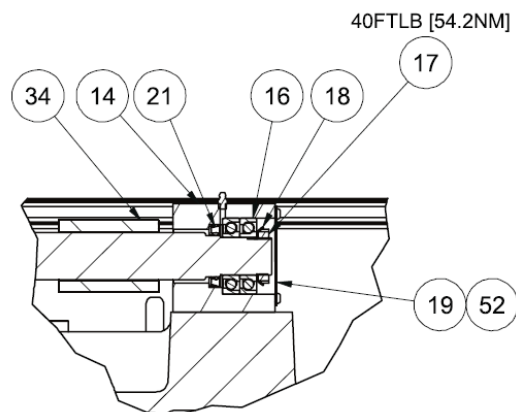

DETAIL D

Parts List			
ITEM	QTY	PART NUMBER	DESCRIPTION
1	1	502-1-19	NAMEPLATE, ROTTLER
2	1	502-11-16X	CONNECTOR, MALE THREAD 1/4 NPTF V6/V8 FIXTURE
3	1	502-11-16Z	CONNECTOR, MALE THREAD AIR FITTING
4	1	502-11-17B	TEE, 1/4 X 1/4"
5	1	502-11-17E	COUPLING 1/4 NPT
6	8	650-3-61S	SCREW, SOCKET BUTTON HEAD 1/2-13 X 5/8"
7	24	6150C	NUT, JACKING SCREW--1-12 UNF-F100
8	24	6150E	JACKING SCREW--1-12 UNF X 5" LONG-FLAT TIP--F100
9	4	6160	NUT, "T"-HARDENED
10	1	6334	STRAIN RELIEF -1" ELECTRONIC ENCLOSURE
11	3	6345	FITTING, MALE BARBED INSERT (AIR HOSE)
12	1	6345B	BRACKET, F80 AIR
13	8	7664N	CAPSCREW, SOCKET HEAD M12x1.75 X 20MM
14	1	9112F	BALLSCREW SUPPORT-X-AXIS -F103,F104,F105
15	1	9112H	X-AXIS BALLSCREW MOUNT (MACHINING) -F103,F104,F105 COLUMN
16	2	9113	BEARING, ANGULAR CONTACT-F103,F104,F105
17	2	9113A	LOCK NUT-F103,F104,F105
18	2	9113B	LOCK WASHER-F103,F104,F105
19	2	9113D	COVER, SUPPORT HOUSING-F103,F104,F105
20	1	9113F	SEAL-F103,F104,F105
21	1	9113G	SEAL-F103,F104,F105
22	4	9113H	BEARING, X-AXIS BALLSCREW
23	1	9113J	NUT, BEARING RETAINING
24	1	9113K	CRS1/CRS11/CRW1/HMS4-Radial shaft seals
25	1	9113M	COUPLING ASSEMBLY-F103,F104,F105
26	2	9114	WAY COVER ASSEMBLY, F-103/104/105
27	1	9201H	X AXIS BALLSCREW - F100
28	1	9201J	SPACER, SEAL X-AXIS BALLSCREW - F100
29	1	9212C	HOUSING, BALLSCREW DRIVE - X-AXIS F107/9 (QUAD BEARING)
30	1	9215F	X-AXIS MOTOR , F103,F104,F105
31	2	9219	CABLE CARRIER, COLUMN TRAVEL-F105
32	2	9219D	TRACK, CABLE CARRIER - F107/9
33	4	9227C	RING, HOIST OR LIFTING EYE - F100
34	1	9232	BALLSCREW OVER TRAVEL SPRING - F103/4/5 - LEFT 4.13" LONG
35	1	9232A	BALLSCREW OVER TRAVEL SPRING - F103/4/5 - RIGHT 3.56" LONG
36	1	9238B	MACHINE BED - F-105AL (MACHINING)
37	1	9241	RAIL, LINEAR (X-AXIS) - F105AL
38	36	10043A	CLAMP, LINEAR RAIL - F106
39	1	10075	BOX, ELECTRICAL JUNCTION - EM100
40	1	10075A	CONNECTOR, BLOCK - EM79 - 109
41	4	MF-8	S.H.C.S.10 - 24 UNC - 2 1/4
42	6	MF-12	SOCKET HEAD CAPSCREW 1/4-20 X 1/2"
43	6	MF-23	SOCKET HEAD CAPSCREW 5/16-18 X 1"
44	4	MF-40	SOCKET HEAD CAPSCREW 7/16-14 X 1 3/4"
45	4	MF-41A	SOCKET HEAD CAPSCREW 1/2-13 X 3 1/2"
46	164	MF-44	S.H.C.S.1/2 - 13 UNC - 1 1/2
47	4	MF-44A	S.H.C.S.1/2 - 13 UNC - 1 3/4
48	4	MF-90	Socket Button Head1/4 - 20 x 1/2
49	4	Mf-92	Socket Button Head1/4 - 20 x 3/4
51	2	MF-191A	Grease Fitting 5/16-18
52	8	MF-248	Socket Button Head1/4 - 20 x 3/8

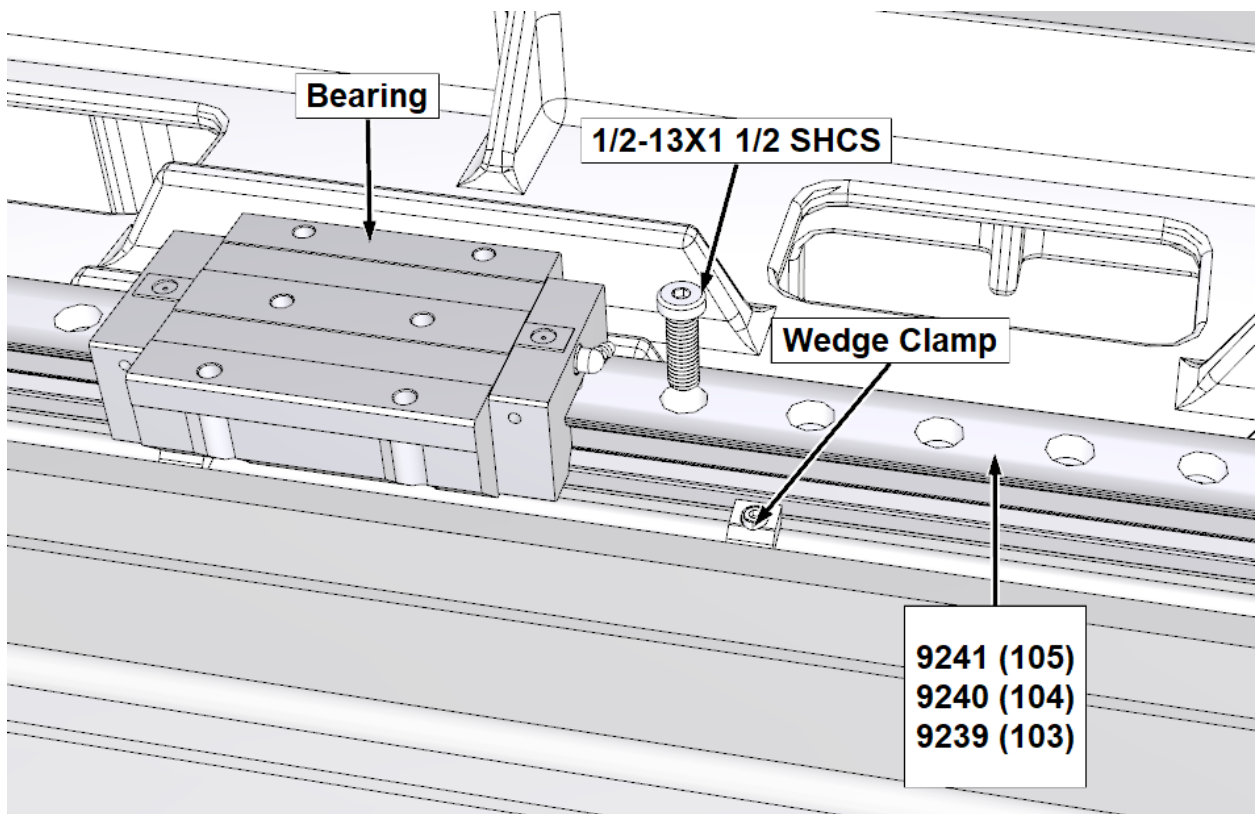
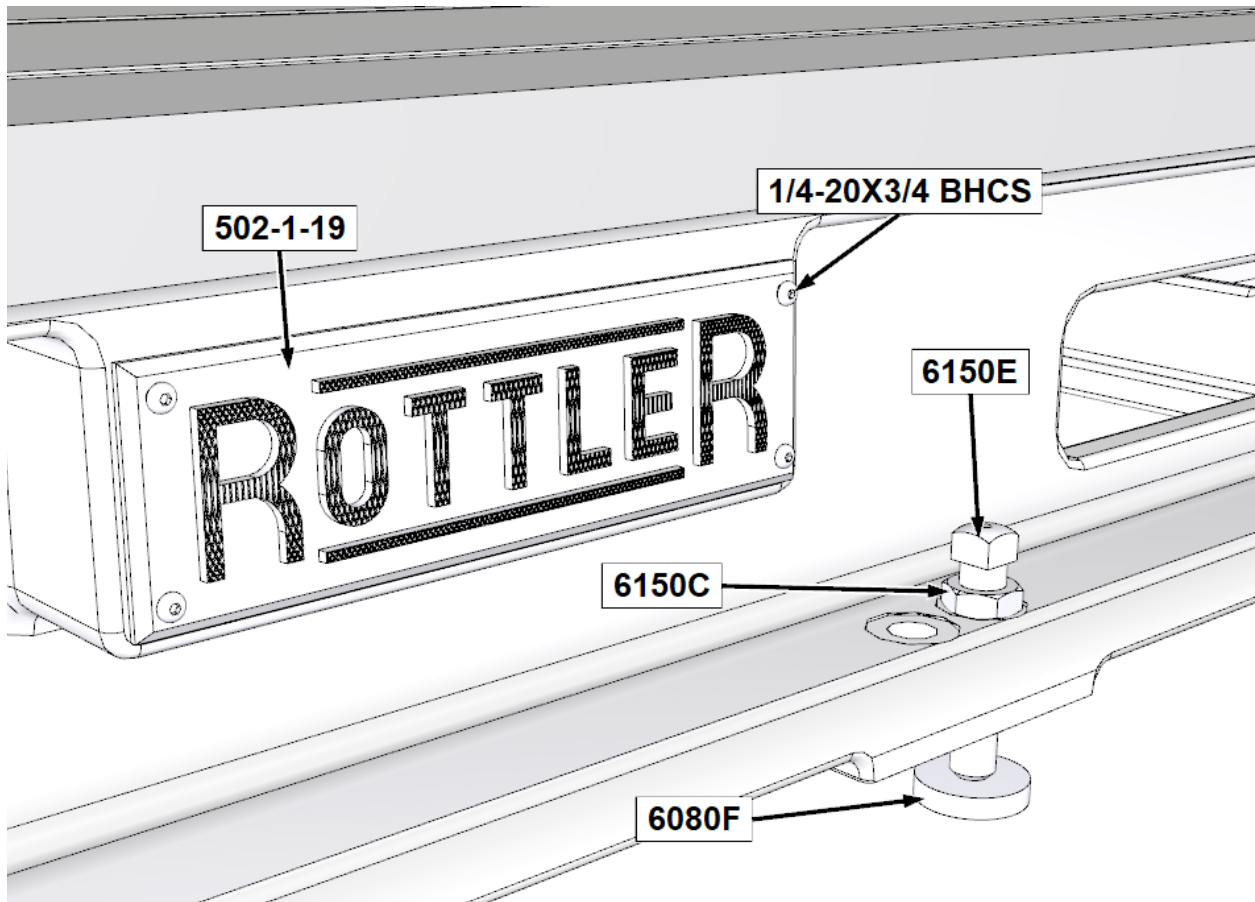

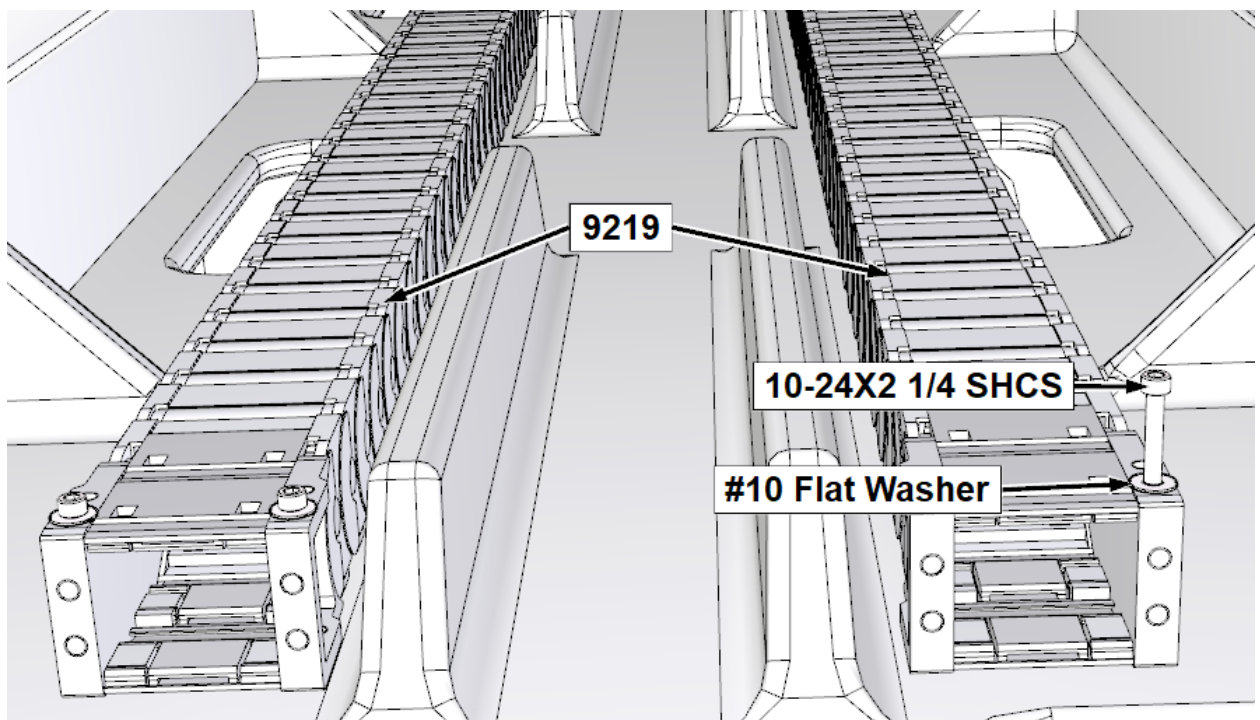
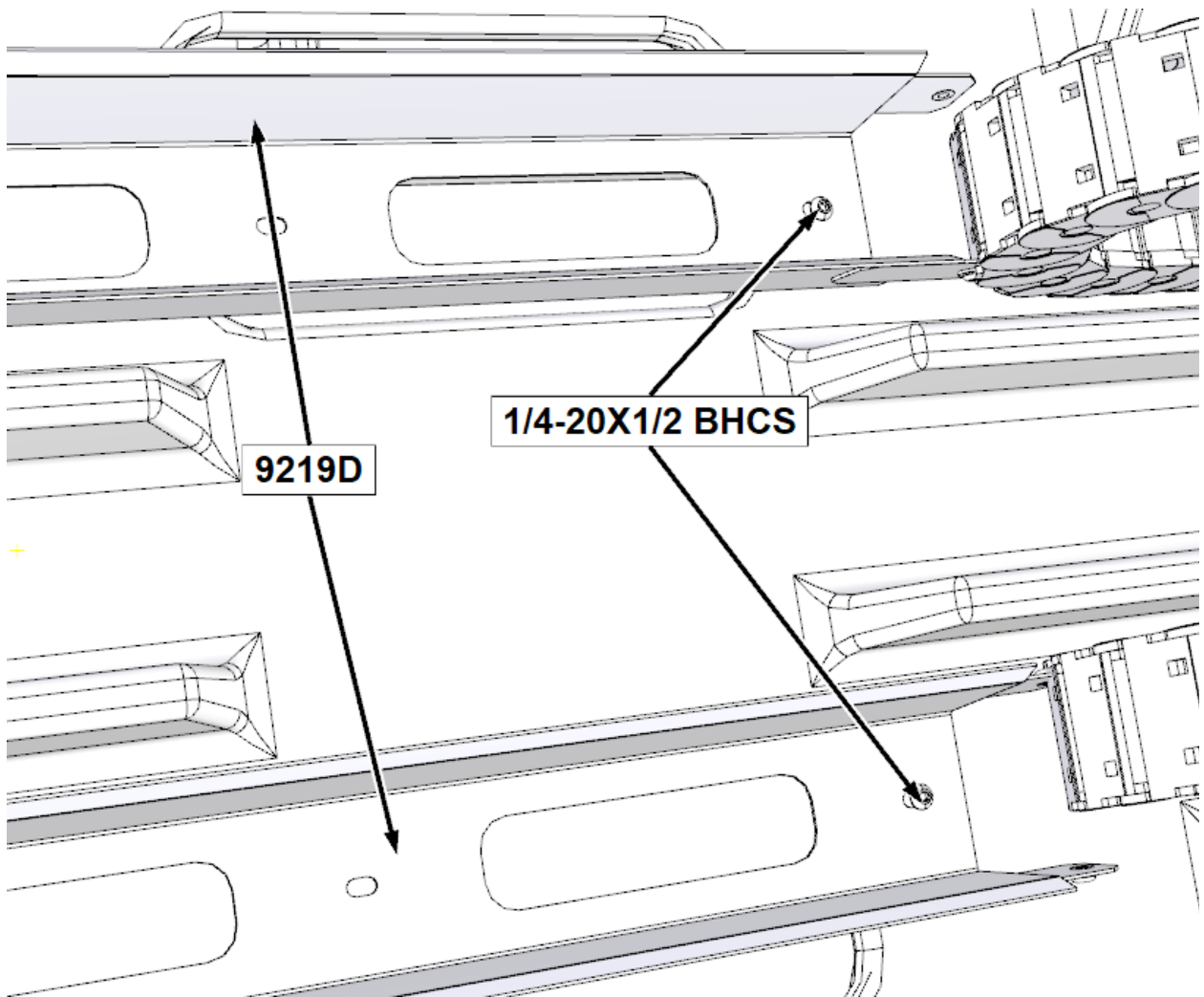

Incoming Power Box Parts

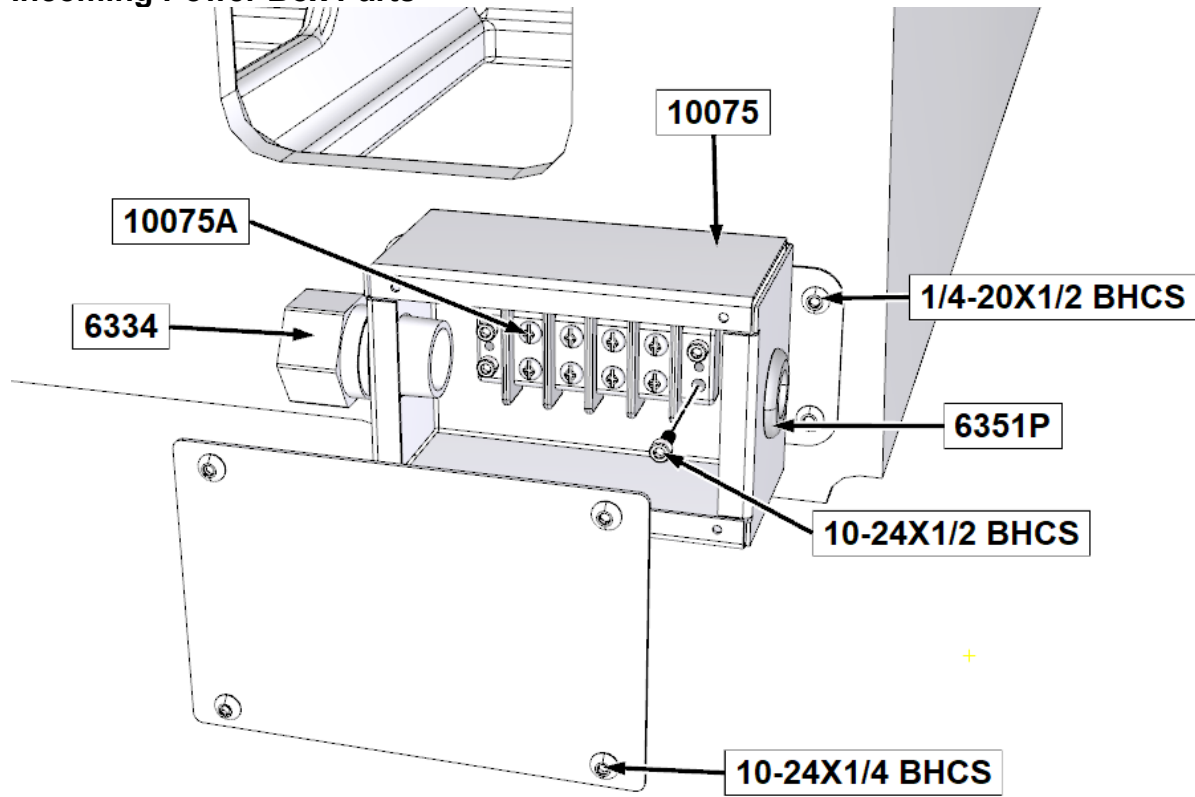

Incoming Air Supply Parts

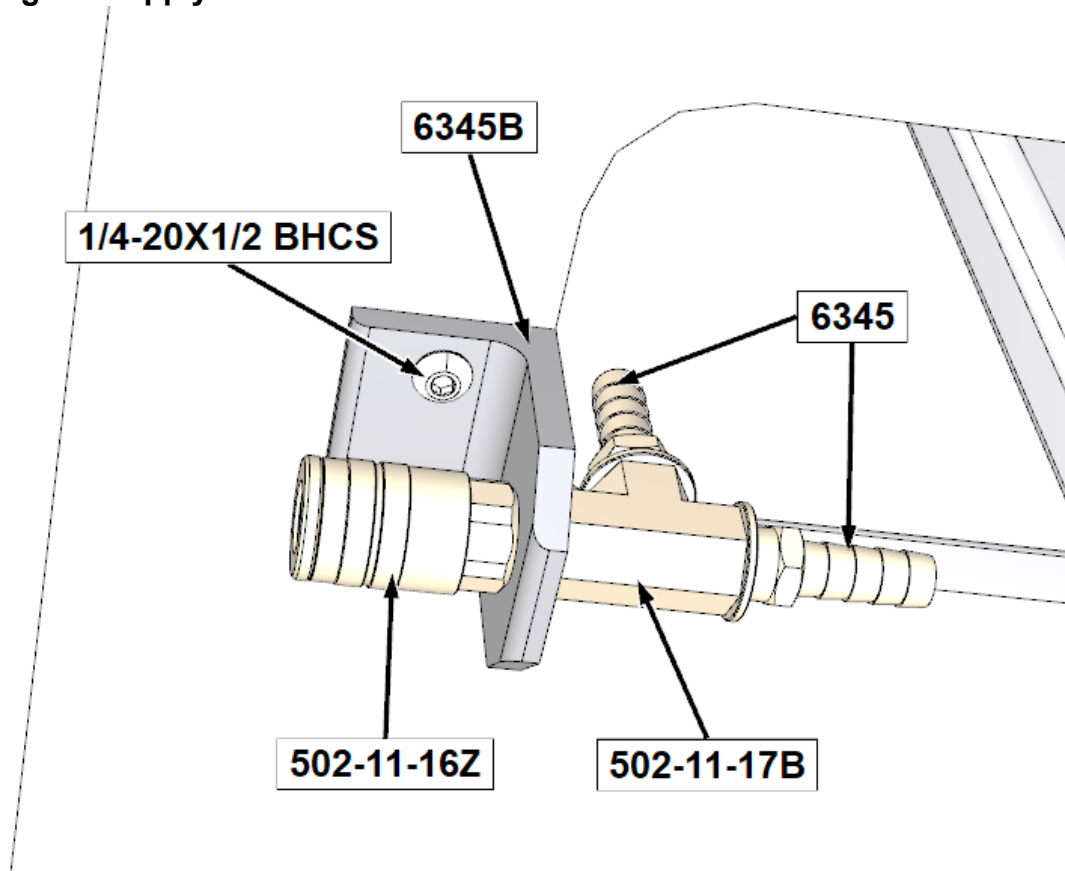

X-Axis Drive Assembly Parts

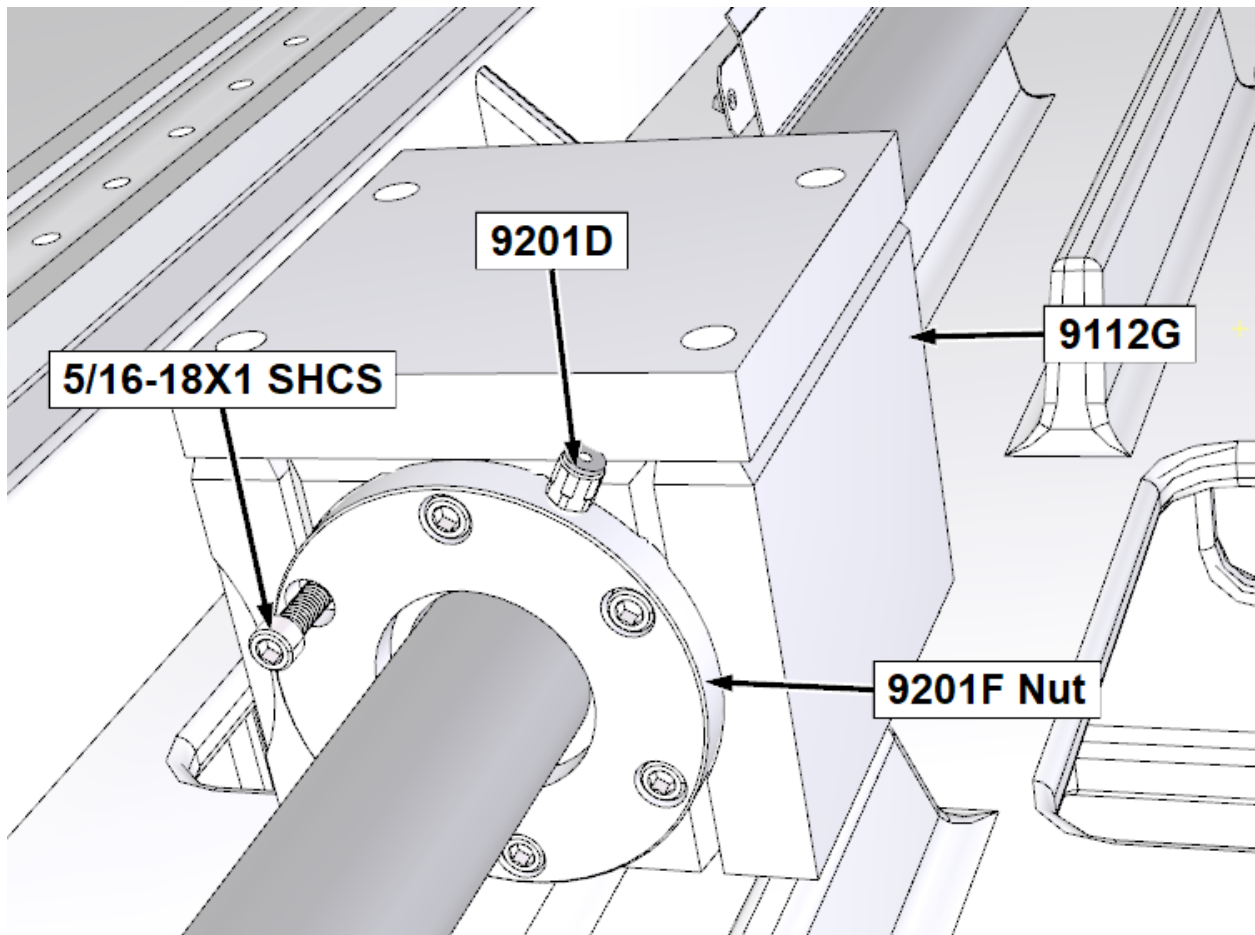
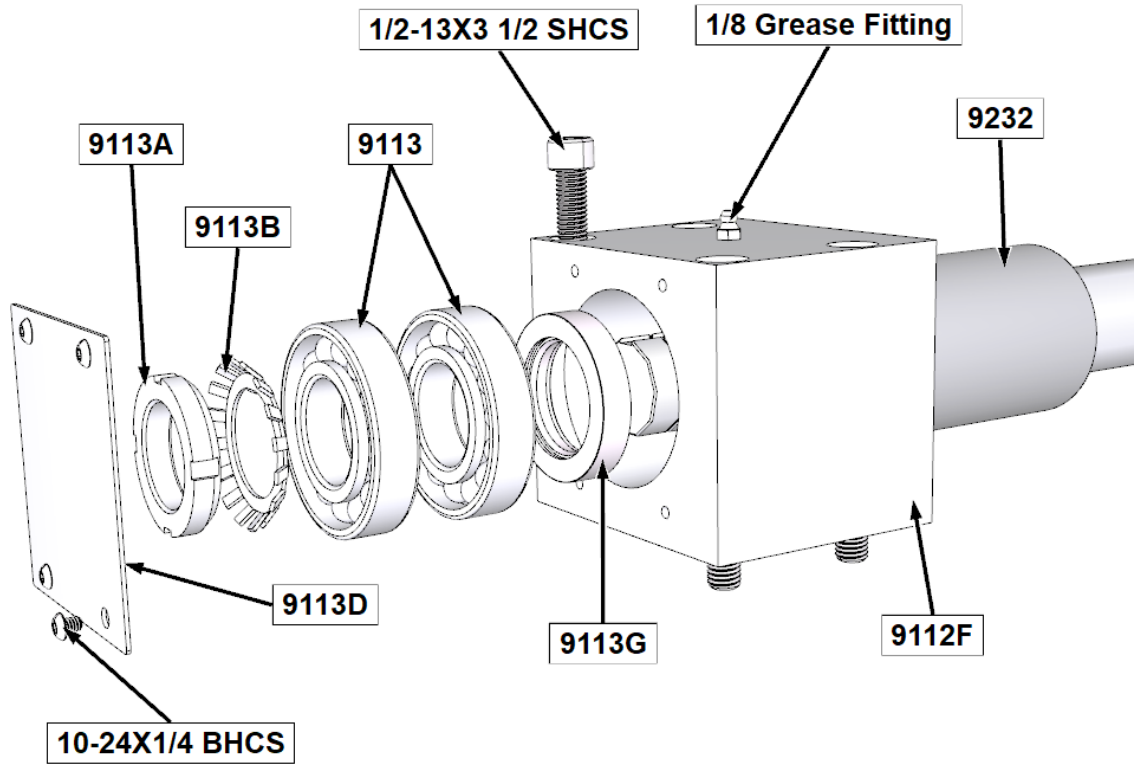

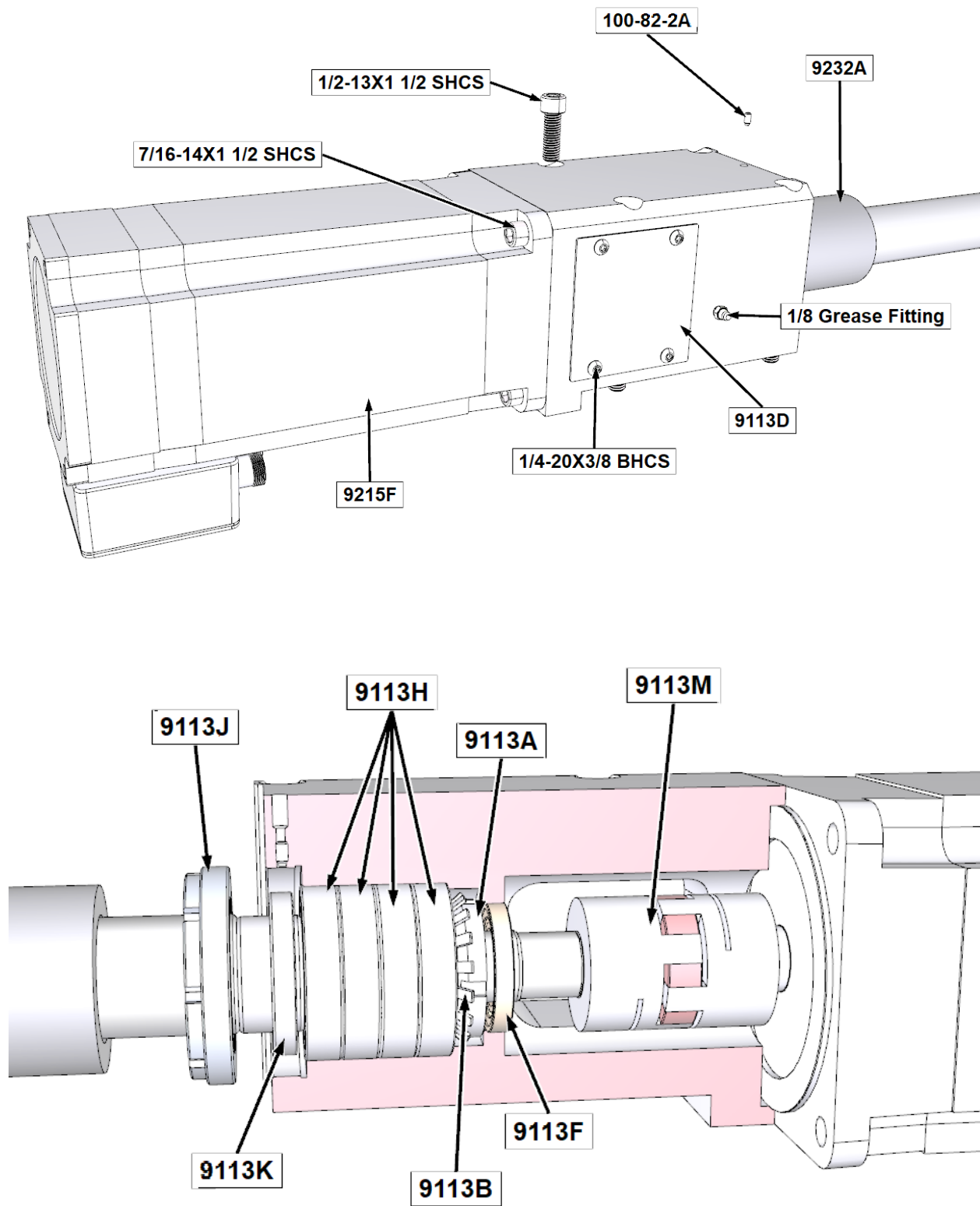

Rail Cover Parts

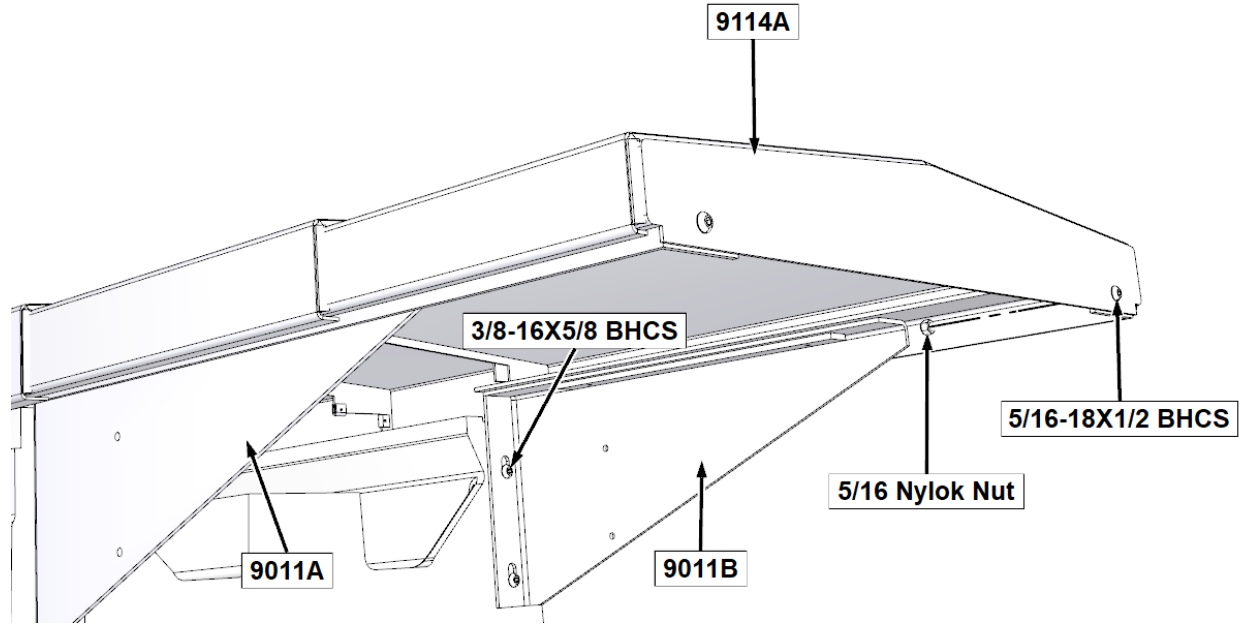

Column Assembly Parts

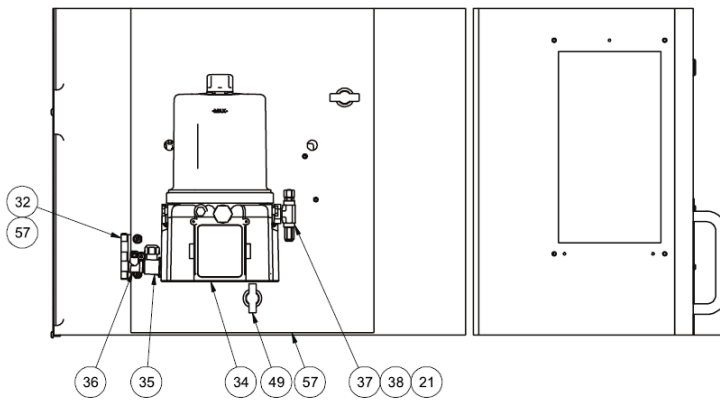
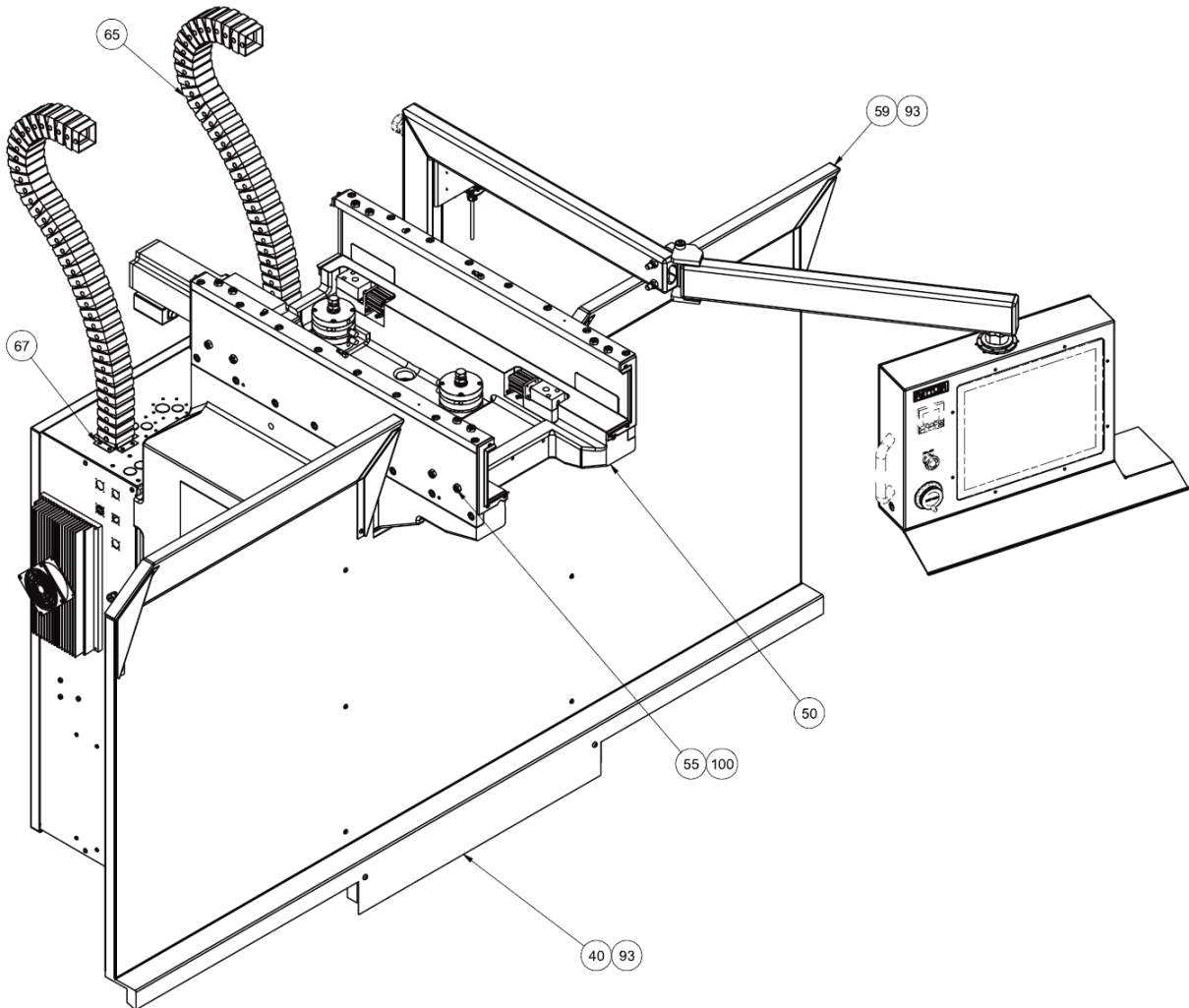

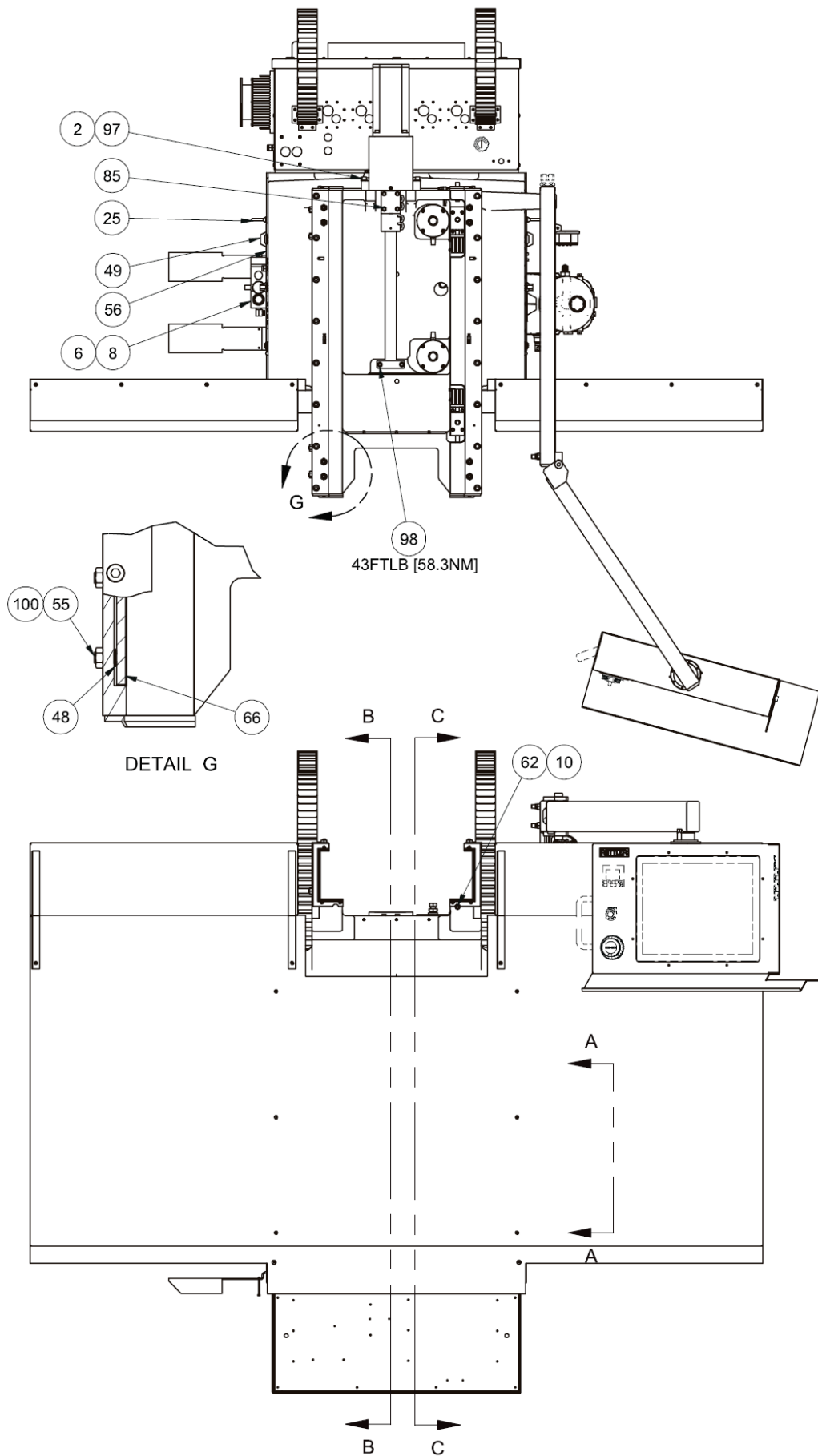

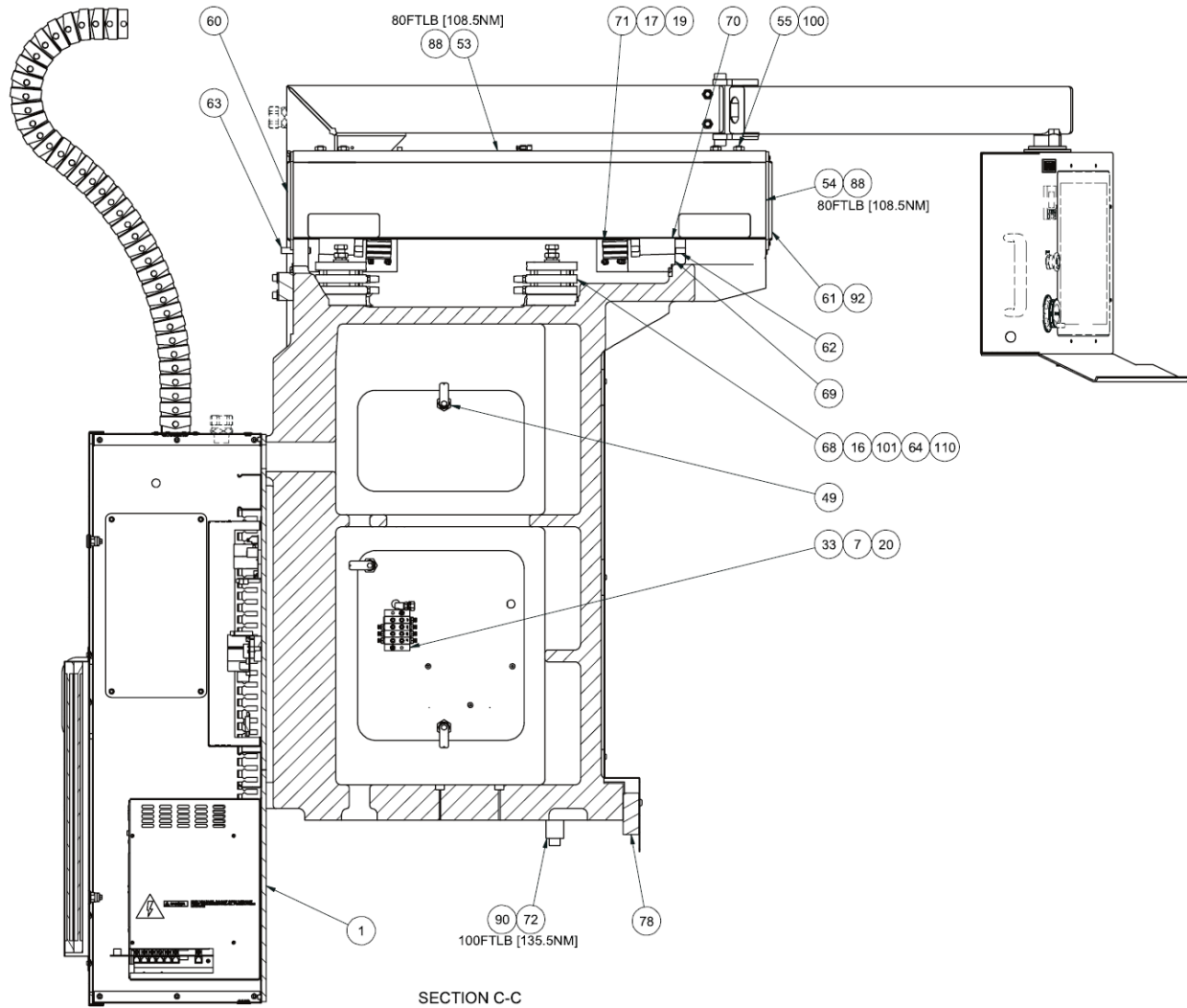

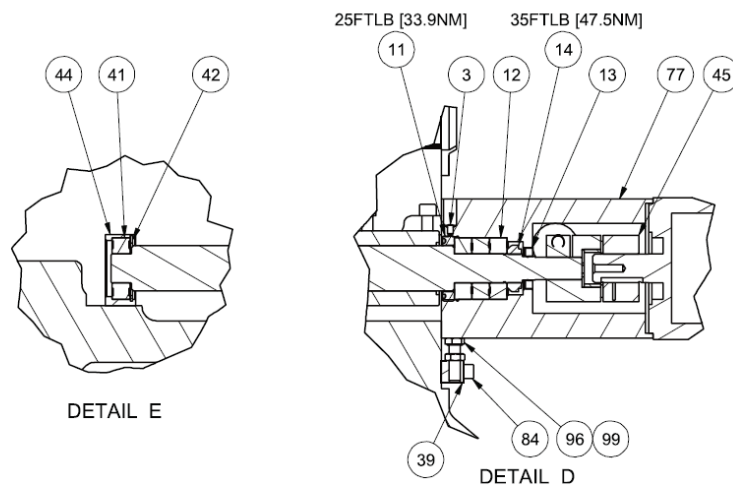
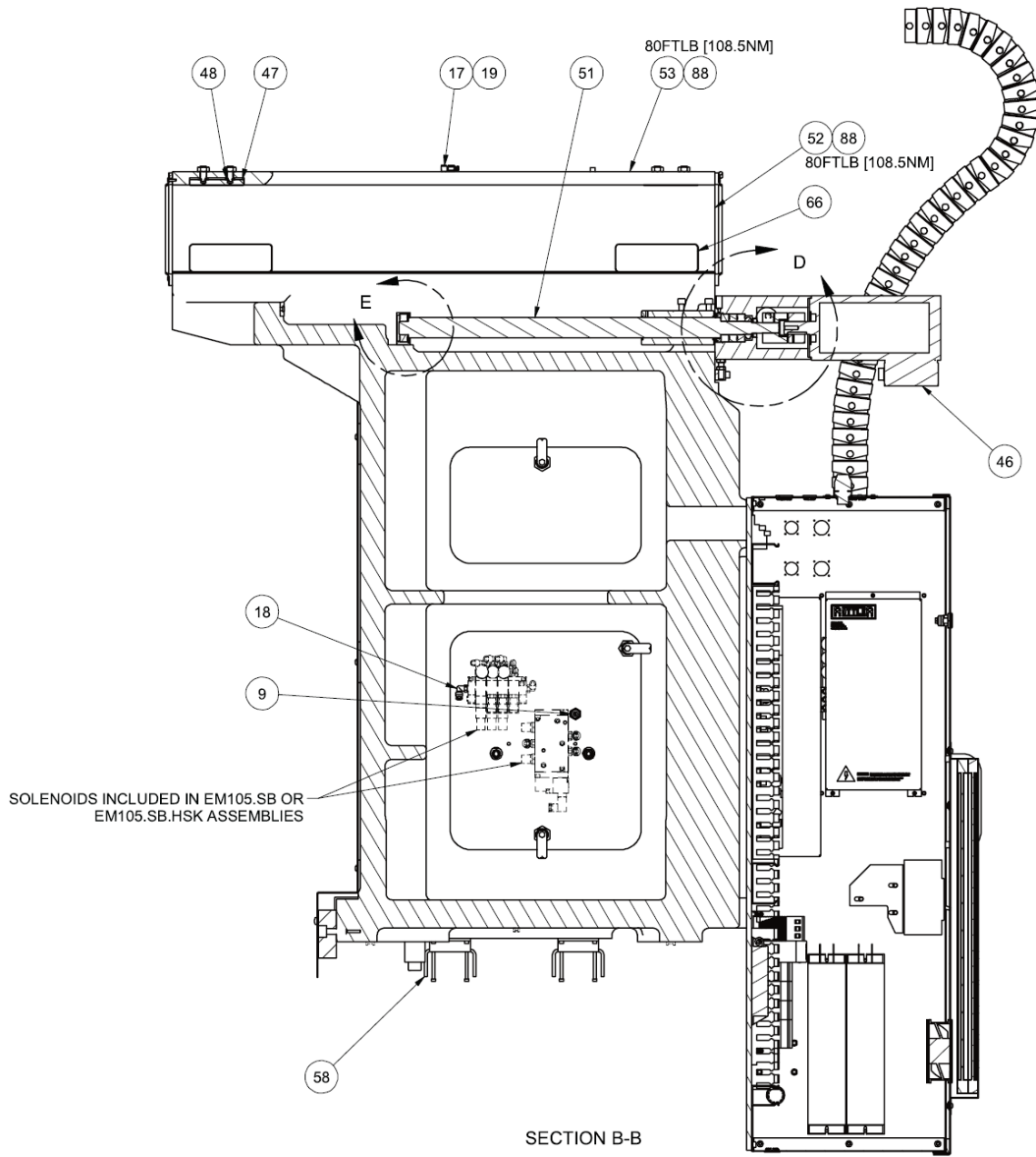

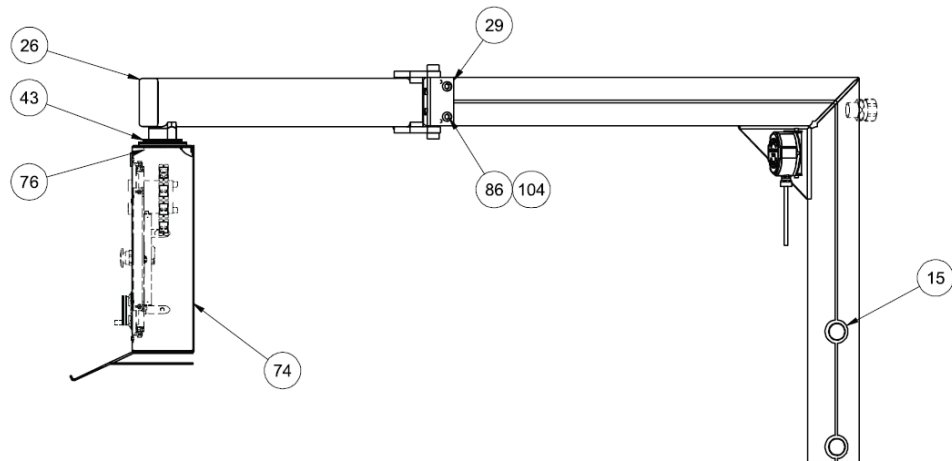
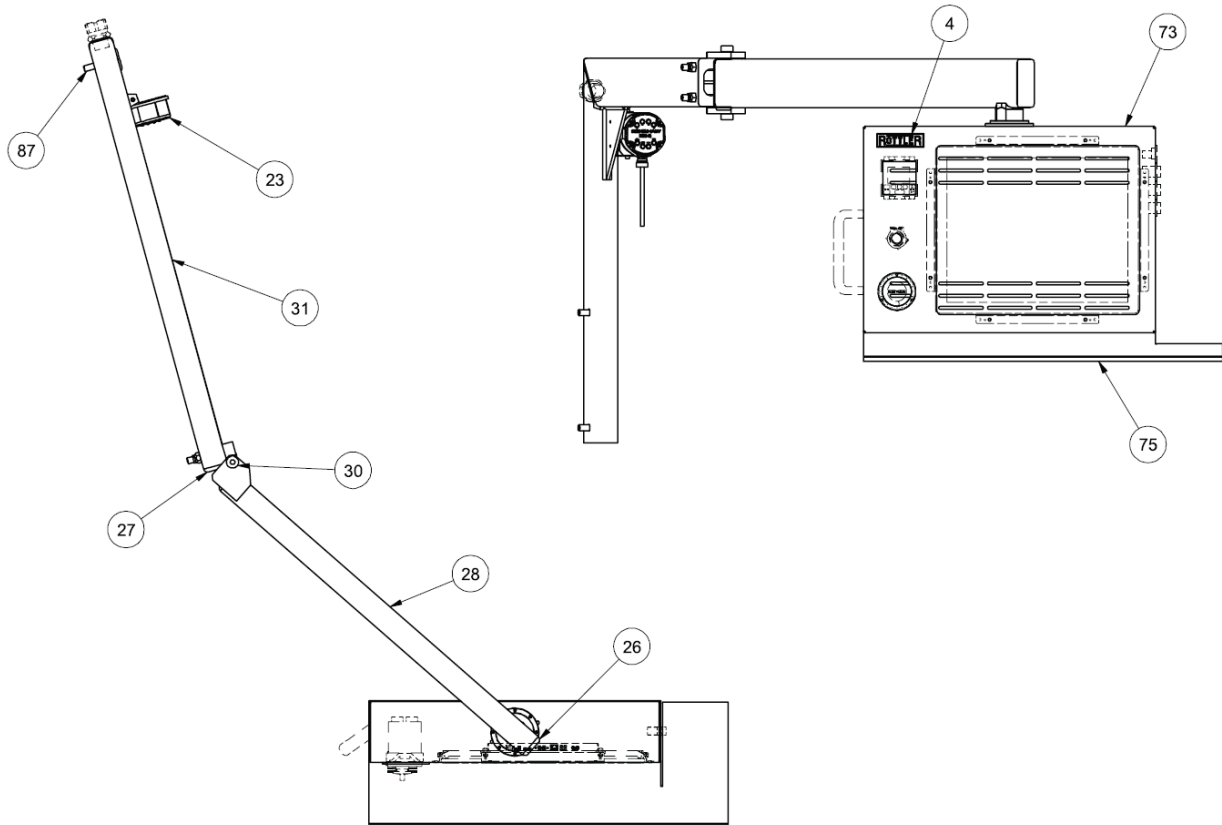

Parts List			
ITEM	QTY	PART NUMBER	DESCRIPTION
1	1	EM100.ELE	ELECTRICAL (FOR EM103/104/105)
2	4	100-28-18	WASHER, FLAT - CLAMP ARM & WEAR PADS
3	1	100-82-2A	SCREW, SET-BRASS GIB - 3/8" LONG
4	2	502-1-19E	BOLT ON NAME PLATE
5	2	502-3-17	WASHER, HOLD DOWN & CLAMP HANDLE
6	1	502-11-17H	BUSHING, PIPE, 1/4NPT x 1/8NPT
7	1	502-11-17R	ELBOW, ST, 1/8 FPT X 1/8 MPT
8	1	502-37-71H	FILTER REGULATOR ASSEMBLY F80e/F79A/F109
9	1	502-37-71N	STRAIN RELIEF F80E SERIES
10	2	504-29-36	BRASS TIPPED SET SCREW 5/16-18UNC x 5/16" LG.
11	1	504-34-15A	NUT, THRUST BEARING SPINDLE FEED F5 SERIES
12	3	504-34-52	BEARING, ANGULAR CONTACT BALL (25 MM) F5 SERIES
13	1	504-34-53	OIL SEAL (.781 ID) F5 SERIES
14	1	504-34-54	LOCKNUT BEARING (BH-05) F5 SERIES
15	2	506-6-8	PLUG, RUBBER 39MM
16	4	514-3-99	MUFFLER, AIR EXHAUST (1/4")
17	8	514-4-16A	FITTING, ADJUSTABLE "L"
18	1	514-4-17E	ELBOW, 90 DEGREE MALE - 1/4" POLY X 1/8" NPT
19	10	514-4-17J	CONNECTOR, MALE - 1/8" OD TO 10-32
20	1	514-4-18J	FITTING 1/8 NPT X 3/8 TUBE-STRAIGHT HYDRAULIC RESEVOIR
21	1	514-4-18K	FITTING 1/4 NPT X 3/8 TUBE STRAIGHT COOLER BRACKET AND BALL VALVE
22	4	514-7-58	VALVE, CHECK (SHORT STROKE)
23	1	650-3-59U	RMP 40 RADIO PROBE HARDWARE KIT
24	6	6147Y	CLAMP, NYLON--3/16"-F90 SERIES
25	4	6190P	EYE BOLT(MACHINING)-3/8" X 1 1/4" -F79A
26	1	6200J	PLUG-TUBING- PENDANT SWING ARM F80 SERIES
27	2	6200L	PLUG-TUBING- PENDANT SWING ARM F80 SERIES (REWORK OF 6200J)
28	1	6200P	ARM, SWING - PENDANT HOUSING - EM79 & EM103/4/5
29	1	6201H	HINGE BLOCK, PENDANT F80 SERIES
30	2	6201J	BOLT, PIVOT-PENDANT F80 SERIES
31	1	6201V	SWING ARM SUPPORT F70/100 (MACHINING)
32	4	6340P	HINGE, AIR ACCESS DOOR F80E
33	1	6349K	FEEDER, FLO-OILER - EM79/103/104/105
34	1	6363	PUMP, OIL DISTRIBUTION - EM70/100
35	1	6363A	CONNECTOR, OILER POWER - EM70/100
36	1	6363B	CONNECTOR, LOW LEVEL OILER - EM70/100
37	1	6363C	ADAPTER, OILER OUTPUT - EM70/100
38	1	6363D	VALVE, OILER RELIEF - EM70/100
39	1	6451Q	BLOCK, ADJUSTING-BELT-SERVO MOTOR
40	1	6584K	PANEL, SHIELD F99Y
41	1	6778D	BEARING, MIDDLE-VERTICAL SHAFT HEAVY DUTY LINE BORE HEAD F88
42	1	7245E	RETAINING RING-SF
43	1	7322C	BEARING, SLEWING RING
44	1	9001A	BALLSCREW SUPPORT-Y AXIS (F90 SERIES)
45	1	9001Q	COUPLING ASSEMBLY - EM79/100 FOR Z & Y AXIS
46	1	9020H	MOTOR WITH BISS ENCODER-XYZ AXIS-F60/P60 AND Y AXIS ON F103,F104,F105,F109
47	4	9024A	GIB ASSEMBLY-SPRING-F90 COLUMN WITH SOLID Y-AXIS WAYS
48	24	9024E	SPRING,BELLEVILLE-GIB F90 SERIES
49	6	9030E	DOOR LATCH ,COLUMN AND AIR ACCESS-F100
50	1	9200F	COLUMN, (TURCITE ASSEMBLY) - F103/104/105AL
51	1	9201A	BALL SCREW ASSY, Y-AXIS -DIRECT DRIVE (IN-OUT TRAVEL) -F103/104/105
52	1	9202A	GIB BAR, - COLUMN -F103,F104,F105
53	2	9202B	GIB BAR, -TOP- COLUMN -F103,F104,F105
54	1	9202C	BAR ASSEMBLY, FIXED GIB- COLUMN -F103,F104,F105
55	12	9202D	SCREW,GIB ADJUSTING-SPINDLE BASE
56	1	9205	SIDE COVER, AIR CONTROL -COLUMN -F103,F104,F105
57	1	9205A	SIDE COVER, OILER CONTROL -COLUMN -F103,F104,F105
58	2	9219C	BRACE, CABLE TRACK - F103/4/5
59	2	9223A	CHIP DEFLECTOR, F103,F104,F105
60	2	9224	WAY WIPER,LEFT SIDE-SPINDLE BASE-F103/F104/F105
61	2	9224A	WAY WIPER,RIGHT SIDE-SPINDLE BASE-F103/F104/F105
62	1	9225	ADJUSTING SCREW, SPINDLE BASE TILT-F103/F104/F105
63	1	9225A	HEXAGON SOCKET SET SCREW-FLAT POINT, SPINDLE BASE TILT-F103/F104/F105
64	2	9228A	BOLT,TILT LIFT CYLINDER-F103,F104,F105
65	2	9231C	WIRING TRACK-SPINDLE F103/104/105
66	2	10003L	GIB ASSEMBLY, SPRING F-100 SPINDLE BASE
67	2	10015F	CABLE CARRIER BRACKET(SET OF 2 EACH),SPINDLE BASE-F100
68	2	10018E	CYLINDER TILT/LIFT-F100 SERIES
69	2	10018G	BASE WEDGE, SPINDLE BASE TILT -F70/F109/F105/F104/F103
70	2	10018H	TILT WEDGE, SPINDLE BASE-F70/F109/F105/F104/F103
71	2	10018J	CYLINDER -SPINDLE BASE TILT-F100 SERIES
72	2	10043C	PUSH BLOCK, LINEAR RAIL CARRIAGE - F106
73	1	10410	ENCLOSURE, PENDANT - F60/F70/F100
74	1	10411	COVER, PENDANT ENCLOSURE REAR - F60/F70/F100

Parts List			
ITEM	QTY	PART NUMBER	DESCRIPTION
75	1	10412	TRAY, PENDANT ENCLOSURE KEYBOARD - F60/F70/F100
76	1	10413	SPIN STOP, PENDANT - EM79/103/104/105
77	1	11008A	DIRECT DRIVE HOUSING BALLSCREW SUPPORT-X AND Y AXIS-F70
78	2	11010G	STOP, FRONT BEARING - EM79
79	4	MF-5A	S.H.C.S.10 - 24 UNC - 1/2
80	2	MF-7	S.H.C.S.10 - 24 UNC - 1 3/4
81	8	MF-7A	S.H.C.S.10 - 24 UNC - 2
82	4	MF-8	S.H.C.S.10 - 24 UNC - 2 1/4
83	8	MF-16	S.H.C.S.1/4 - 20 UNC - 1 1/4
84	2	MF-25	SOCKET HEAD CAPSCREW 5/16-18 X 1 1/2"
85	4	MF-31	S.H.C.S.3/8 - 16 UNC - 1
86	2	MF-41A	SOCKET HEAD CAPSCREW 1/2-13 X 3 1/2"
87	2	MF-44	S.H.C.S.1/2 - 13 UNC - 1 1/2
88	32	MF-44	SOCKET HEAD CAPSCREW 1/2-13 X 1 1/2"
89	6	MF-46A	S.H.C.S.5/8 - 11 UNC - 1 1/2
90	4	MF-46G	SOCKET HEAD CAPSCREW 5/8-11 X 2 1/2"
91	3	MF-76	Socket Flat Head 8-32 UNC x 0.375
92	6	MF-88A	Socket Button Head10 - 24 x 1/2
93	21	MF-90	Socket Button Head1/4 - 20 x 1/2
94	2	MF-93A	Socket Button Head 5/16 - 18 x 1/2
95	4	MF-143	HEX BOLT 3/8-16 X 1"
96	1	MF-143A	HEX BOLT 3/8-16 X 1 1/4"
97	4	MF-144	HEX BOLT 3/8-16 X 1 1/2"
98	2	MF-147	HEX BOLT 3/8-16 X 2 1/4"
99	1	MF-164	HEX NUTS 3/8-16 NC
100	12	MF-172	HEX JAM NUTS 1/2-20 NF
101	2	MF-173	JAM NUT5/8 - 11
102	3	MF-179	FLAT WASHERS 1/4"
103	2	MF-180	FLAT WASHERS 1/2"
104	2	MF-186	NYLOCK NUTS 1/2-13 NC
105	15	MF-186A	NYLOCK NUT 1/4-20
106	2	MF-186B	NYLOCK NUTS 10-24
107	1	MF-191A	5/16-32 STRAIGHT LUBE GREASE FITTINGS
108	2	MF-204	DOWEL PINS 1/4 X 1"
109	3	-	SOCKET BUTTON HEAD 1/4-20 X 1 1/4"
110	8	-	S.H.C.S.1/4 - 20 UNC - 4 1/4

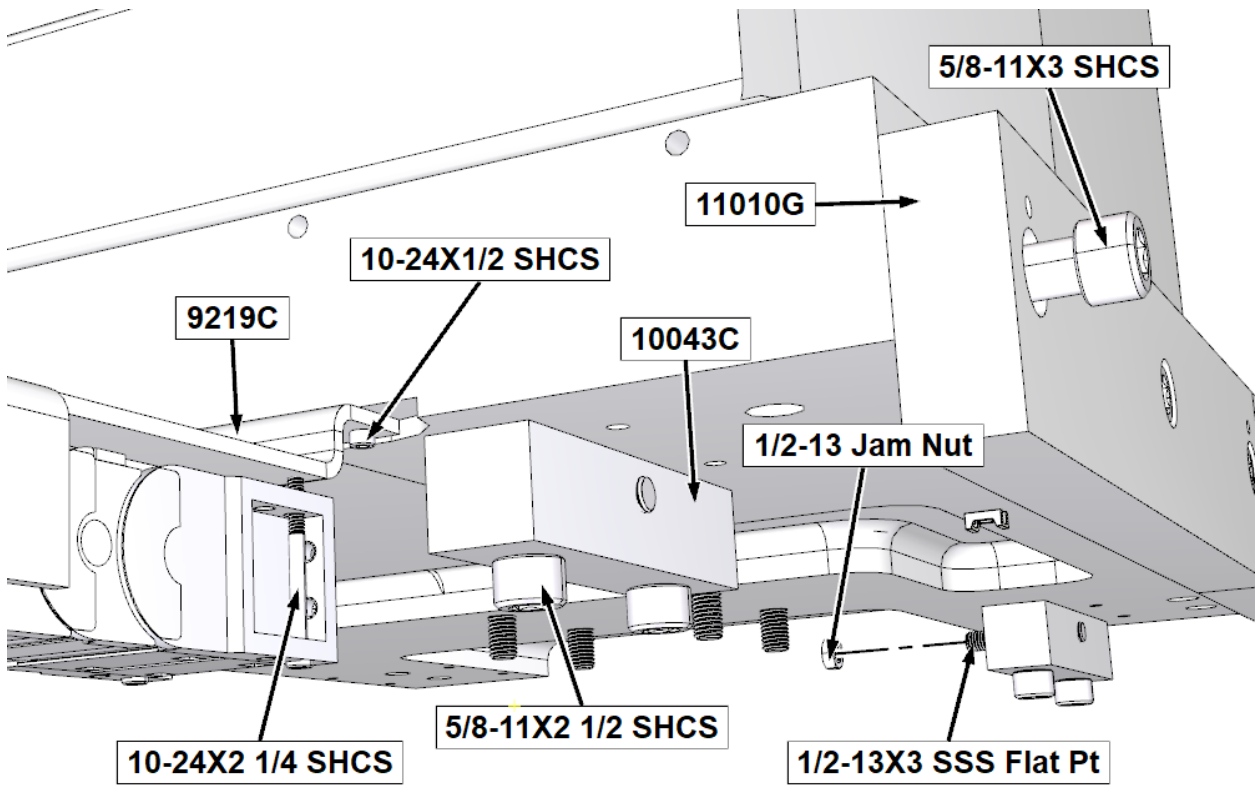
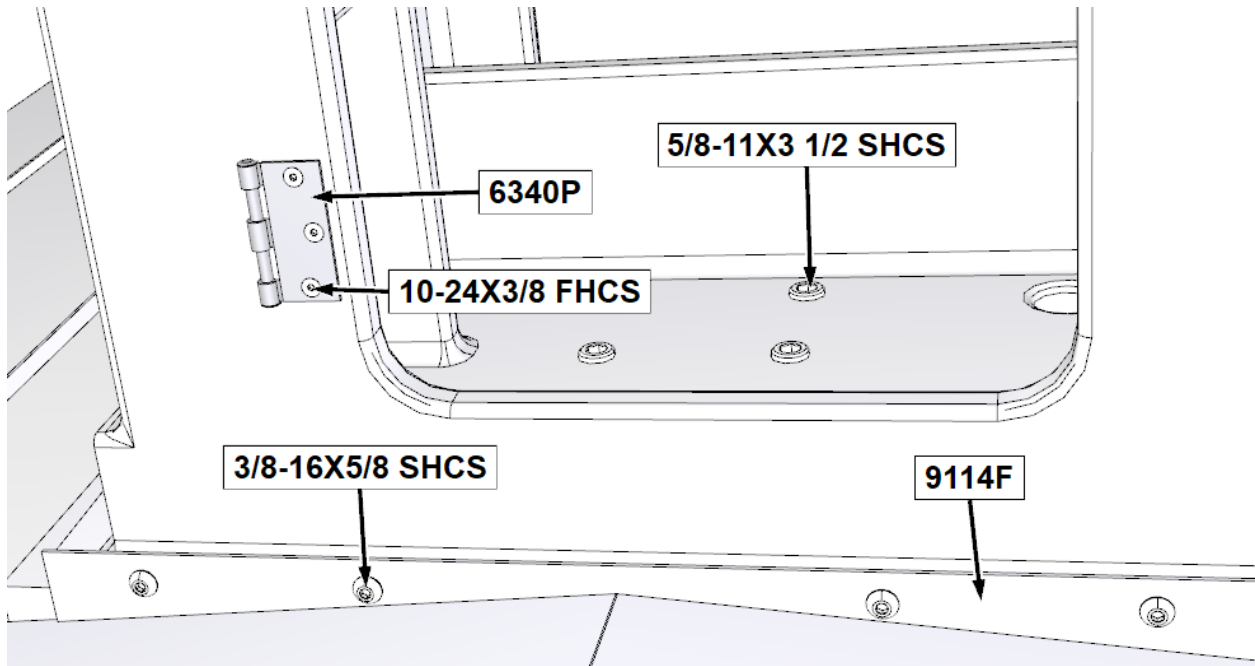

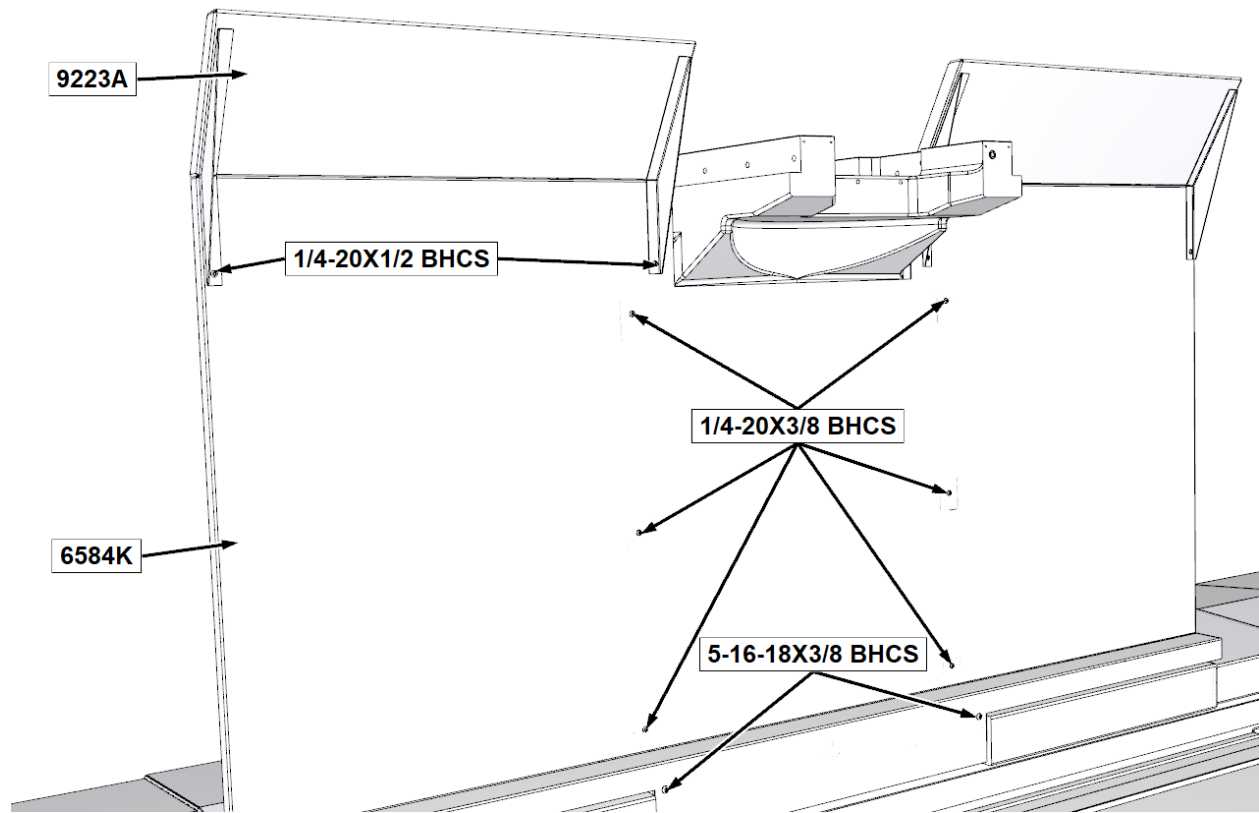

Air Door Parts

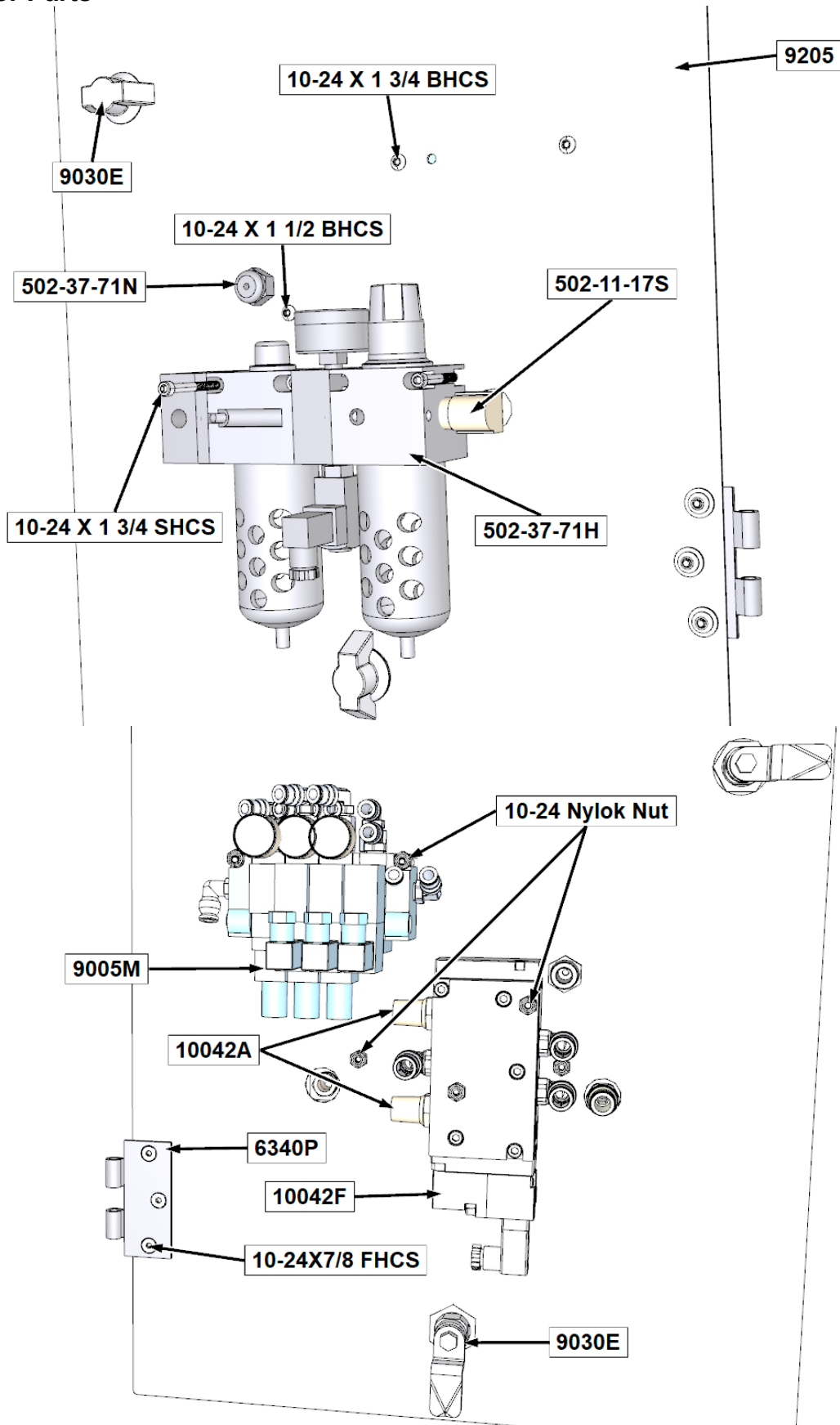

Oiler Door Parts

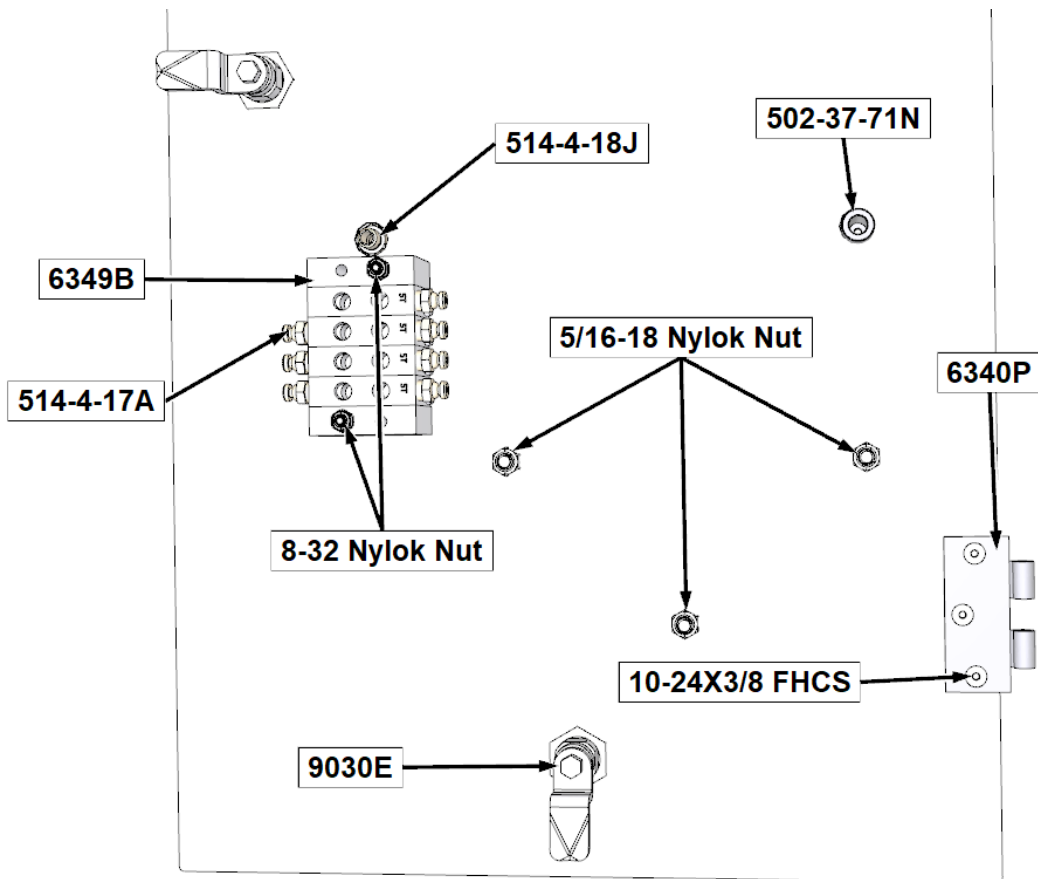
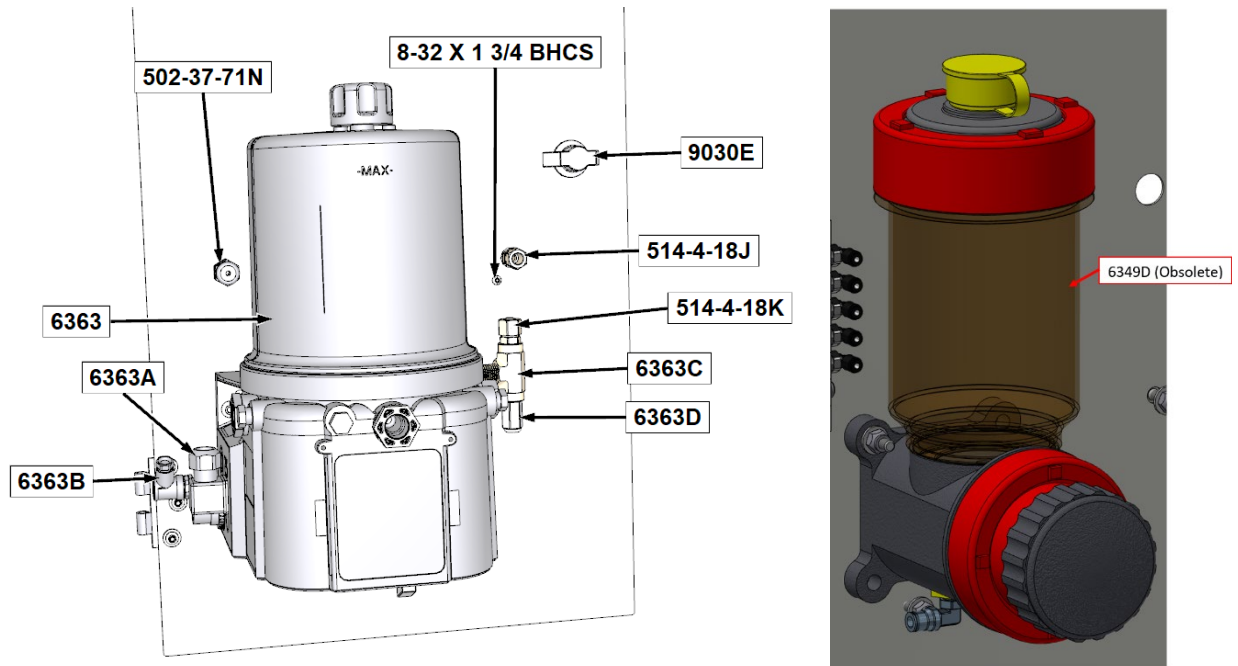

Y-Axis Drive Assembly Parts

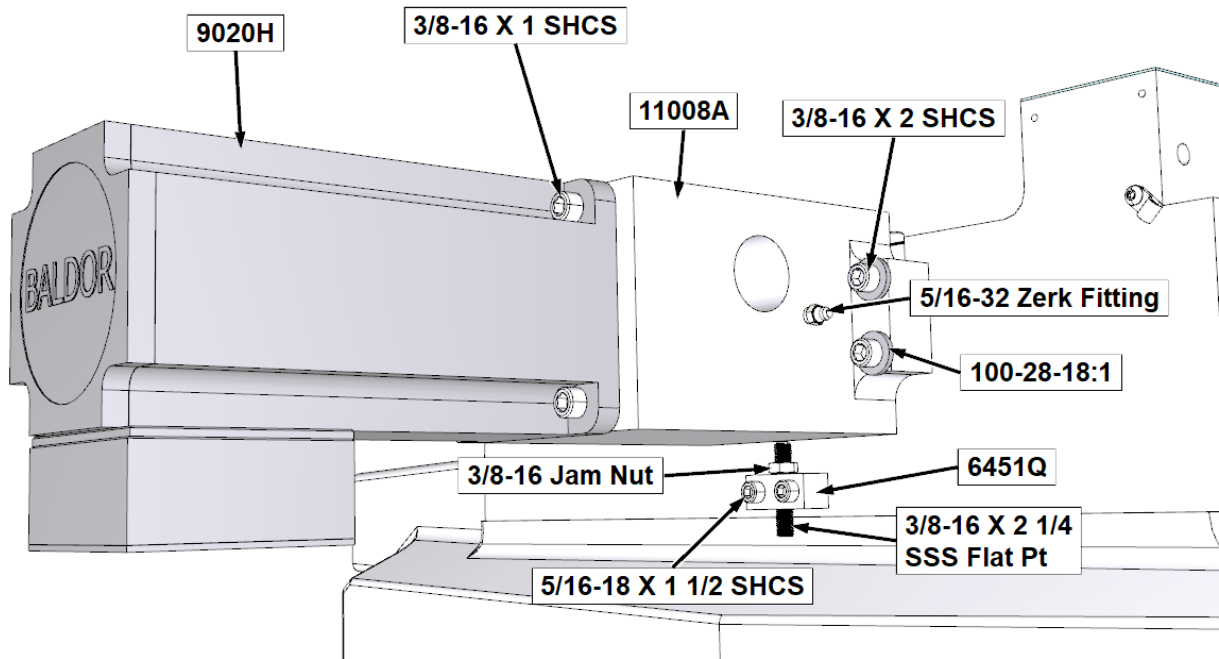
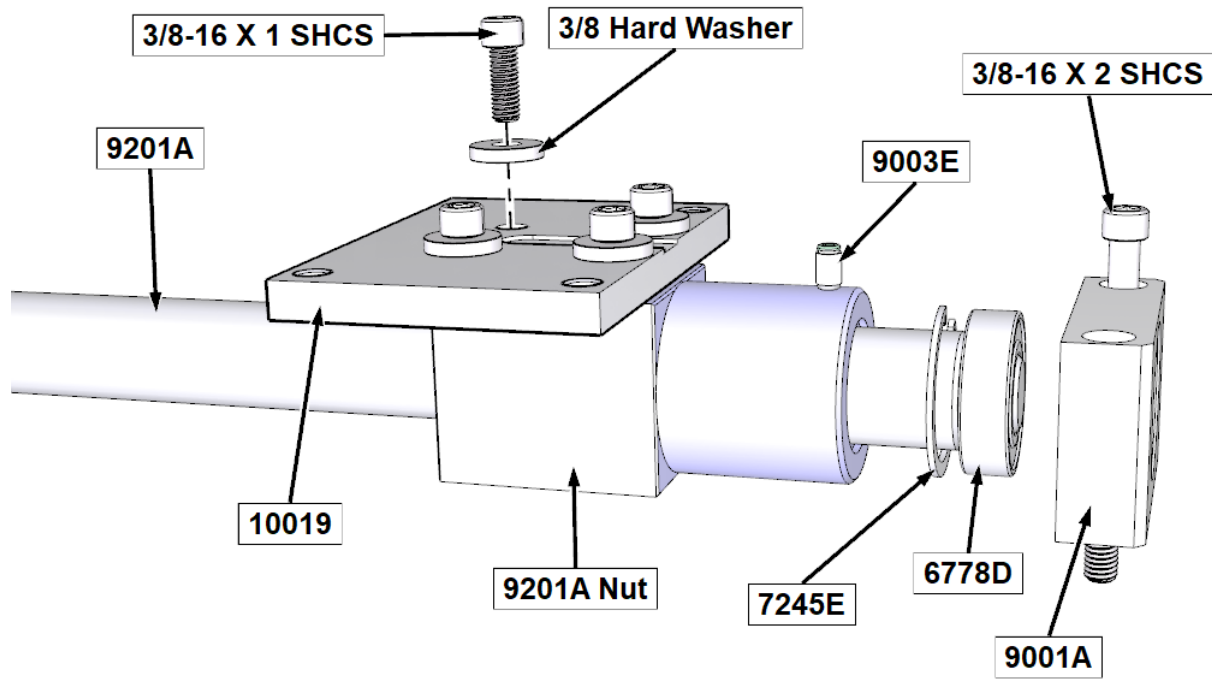

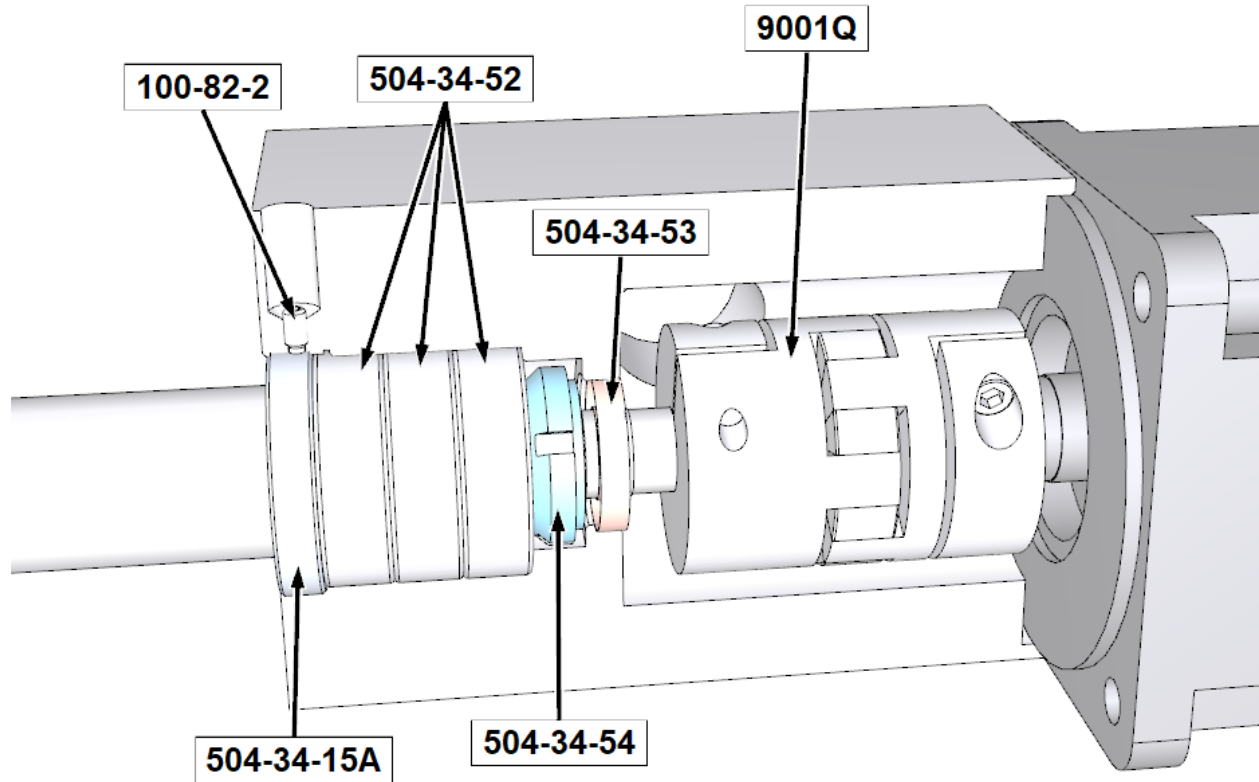

Mill Mode Tilt Wedge Assembly Parts

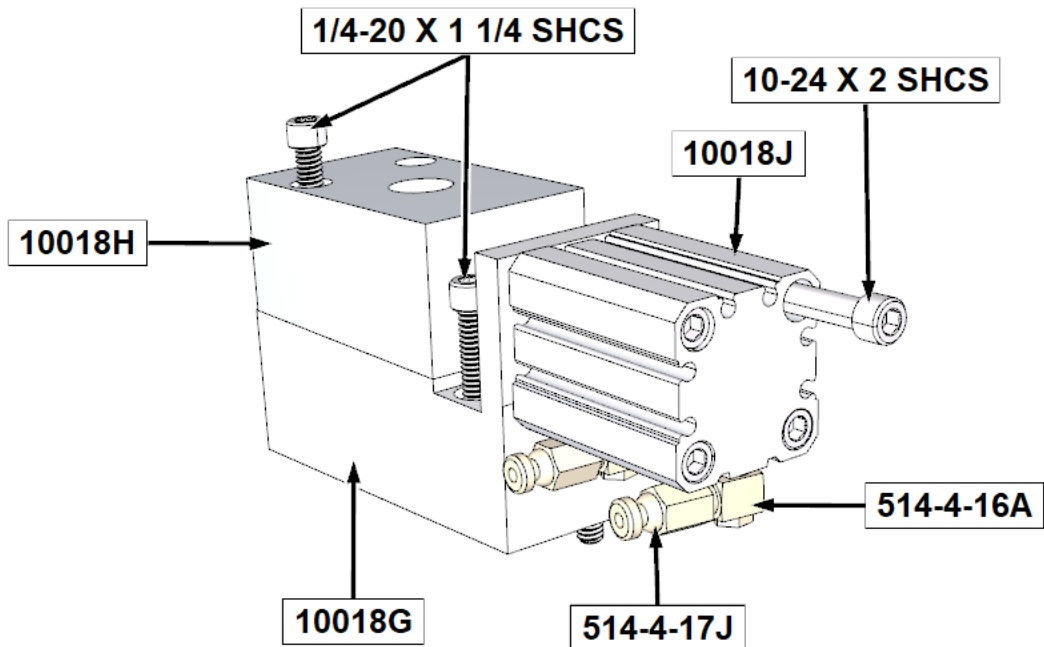

Mill Mode Lift Cylinder Assembly Parts

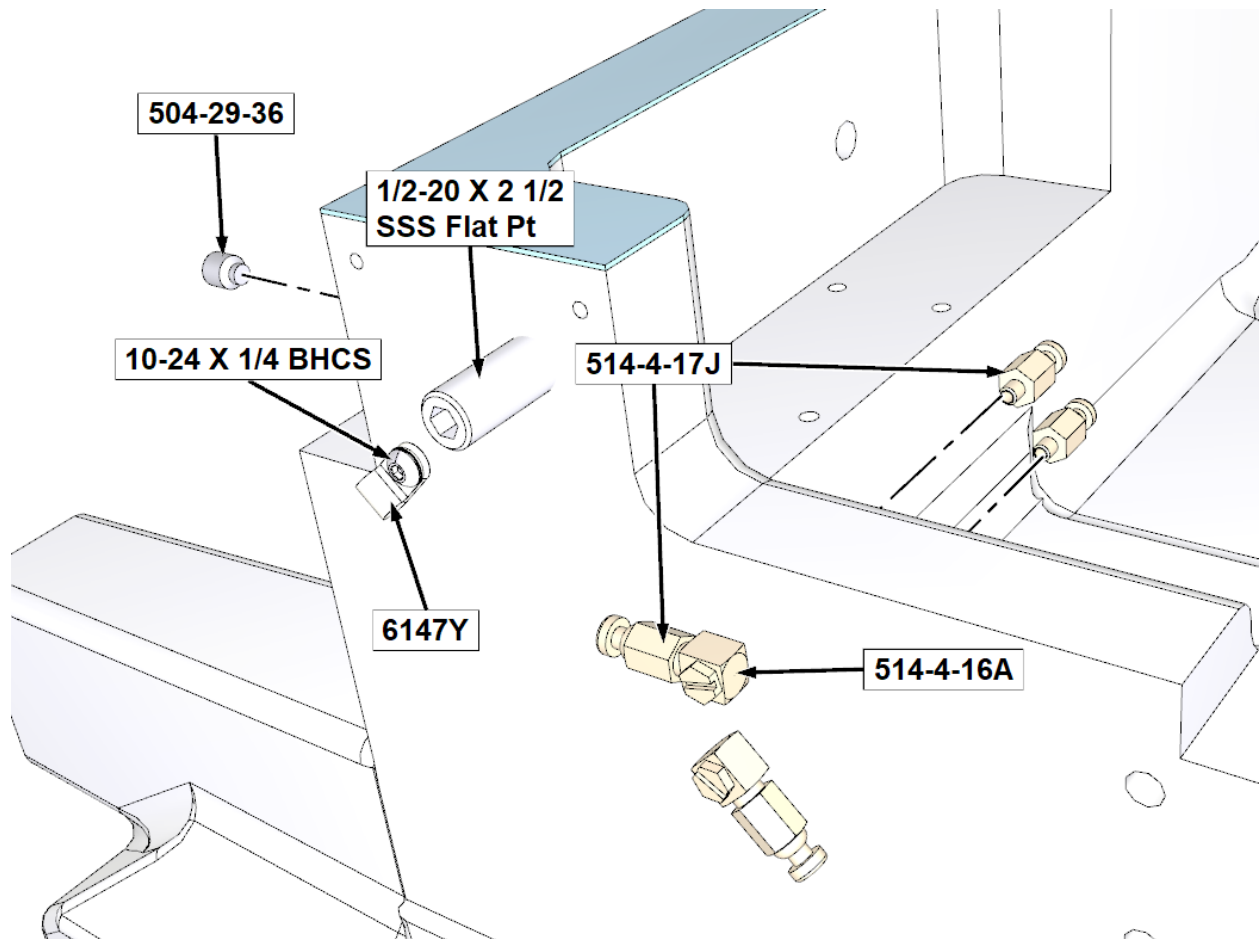
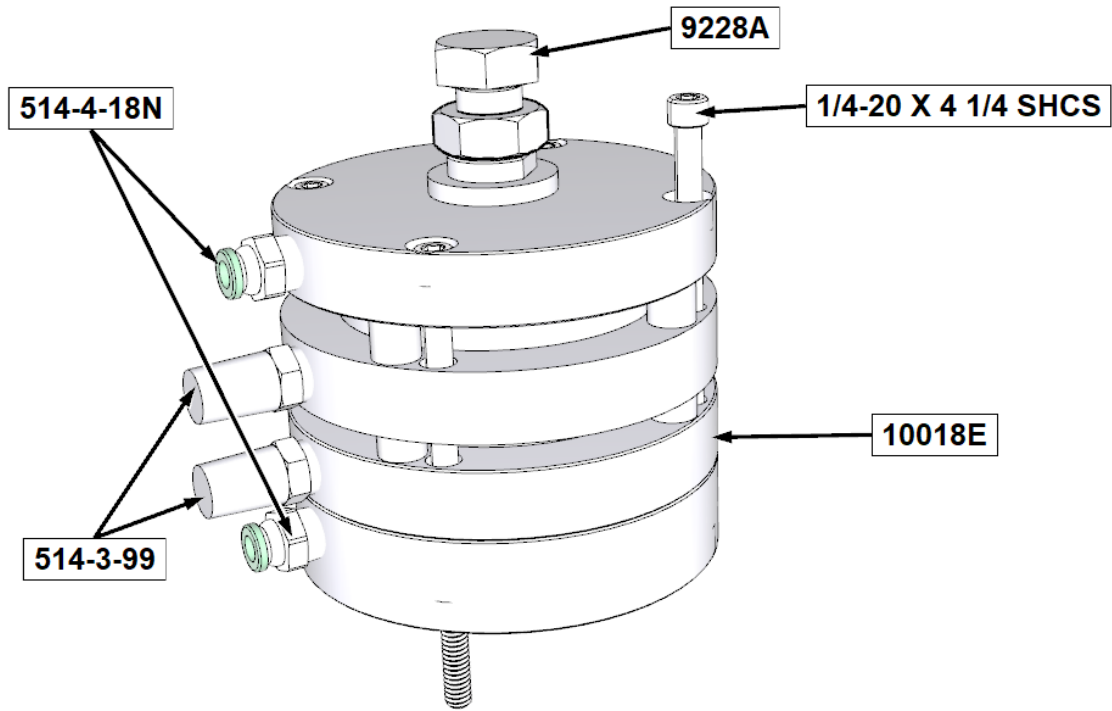

Gib Assembly Parts

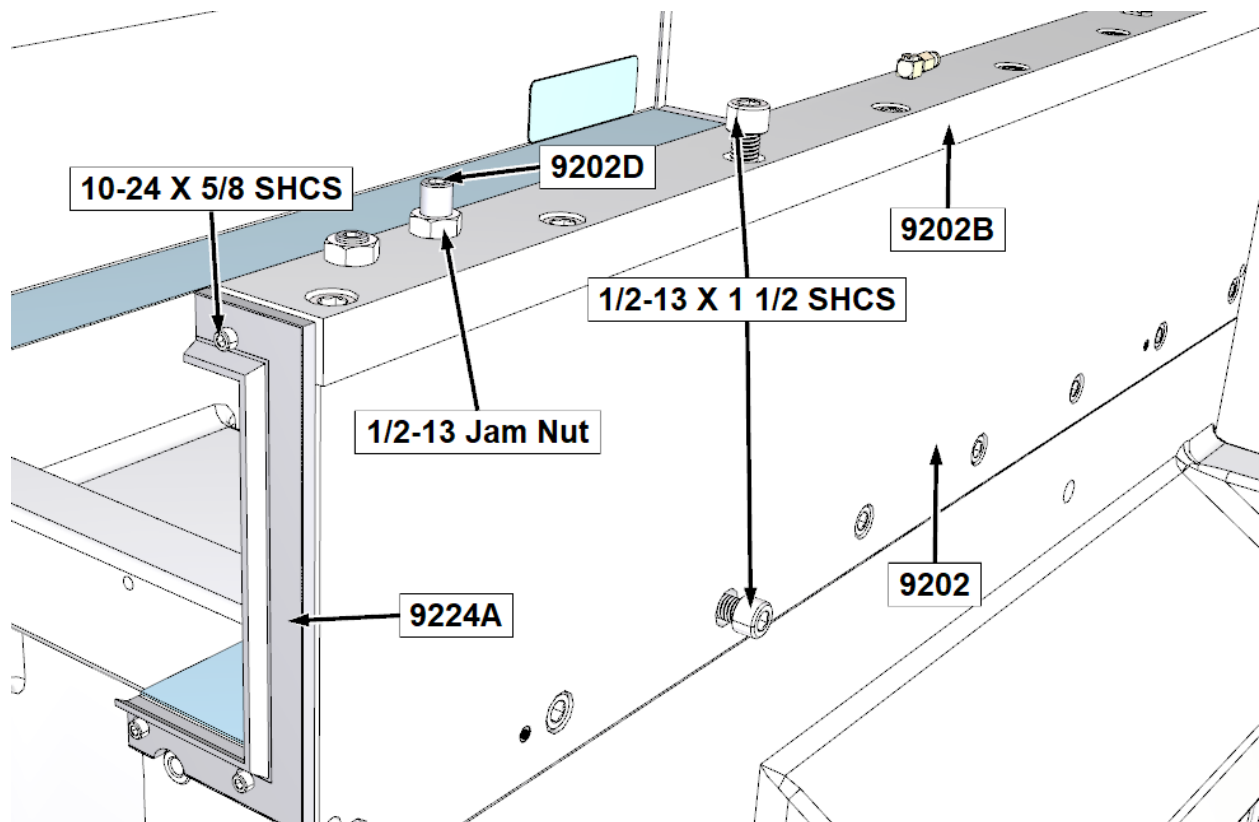
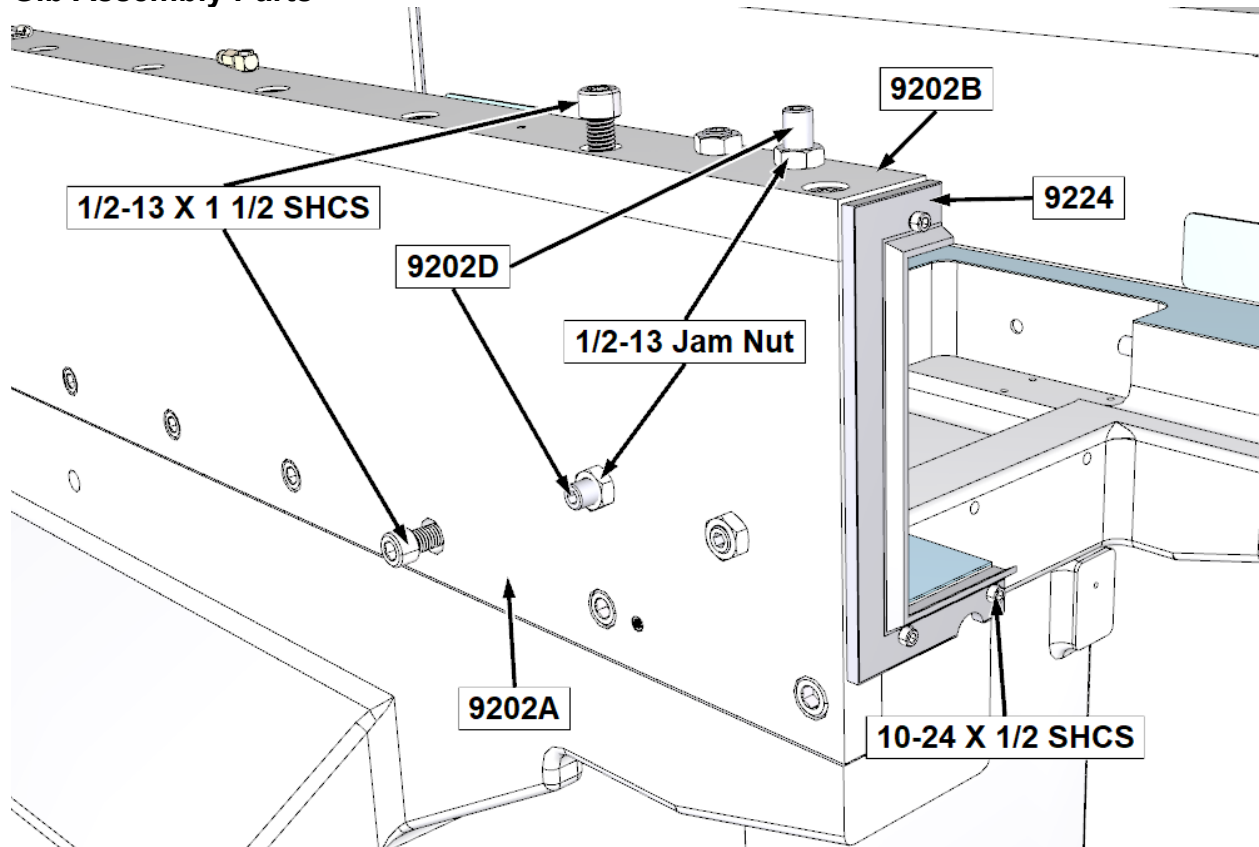

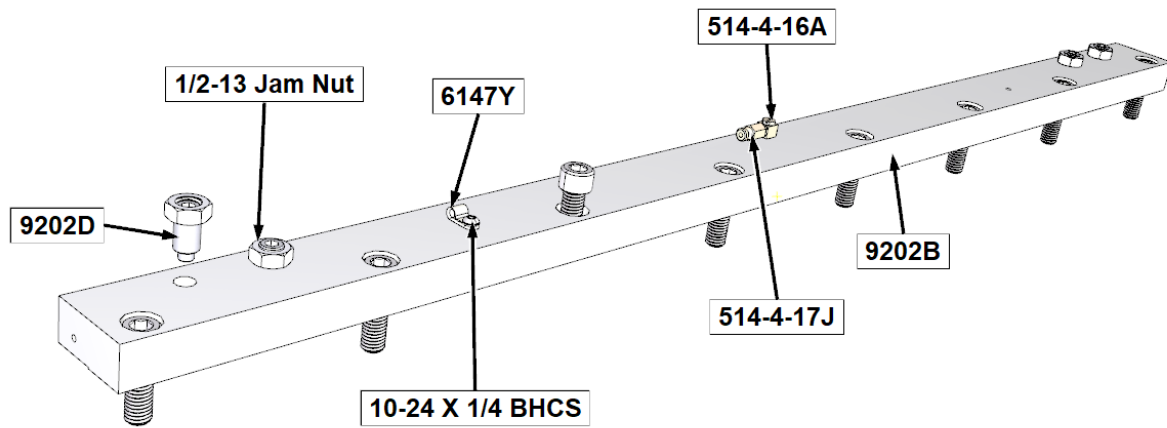
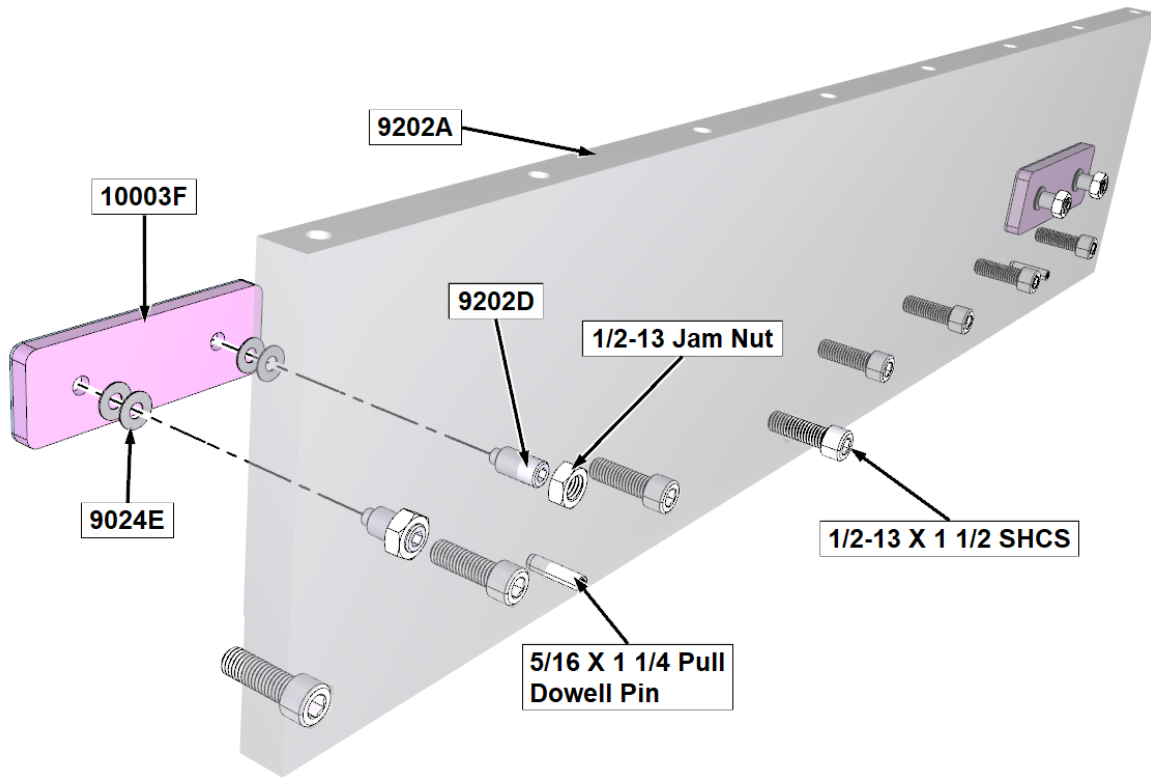

Pendant Assembly Parts

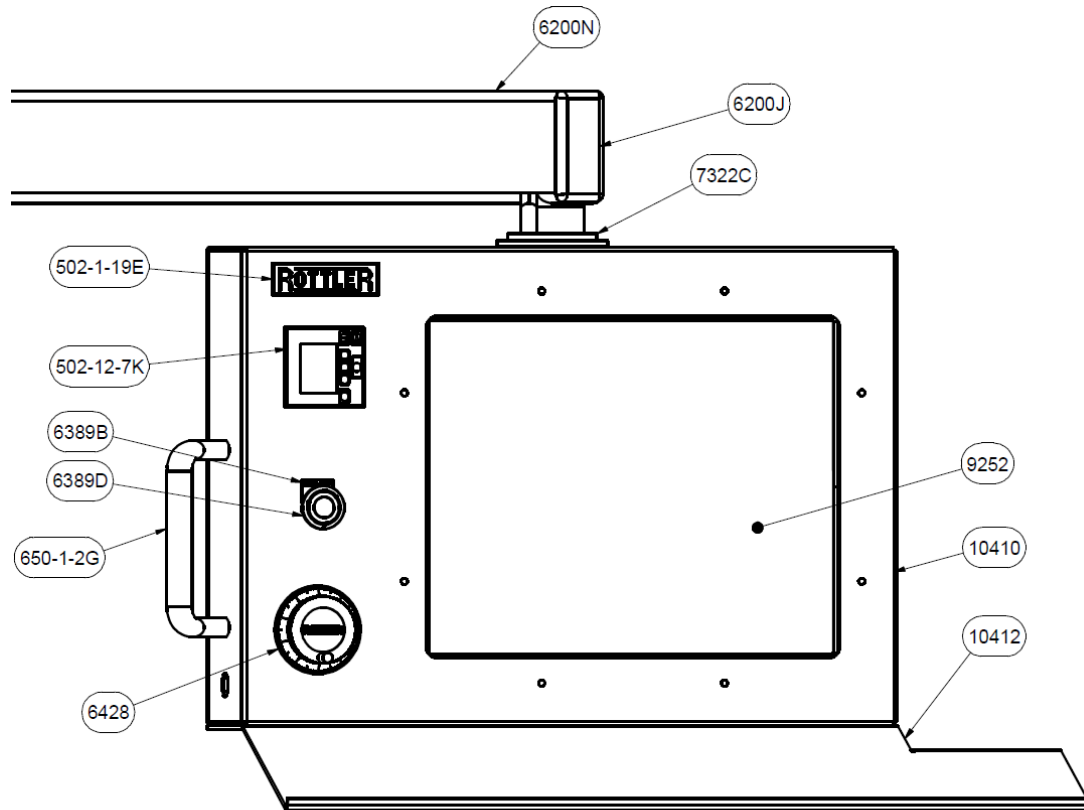
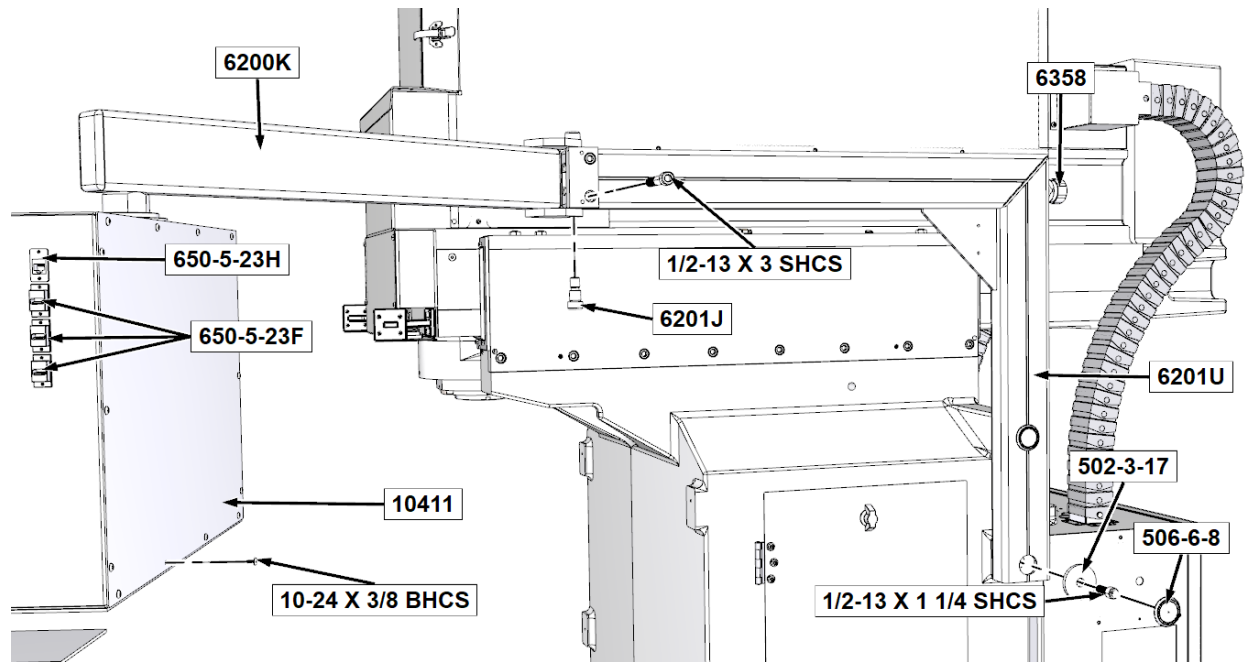

Spindle Base Assembly Parts

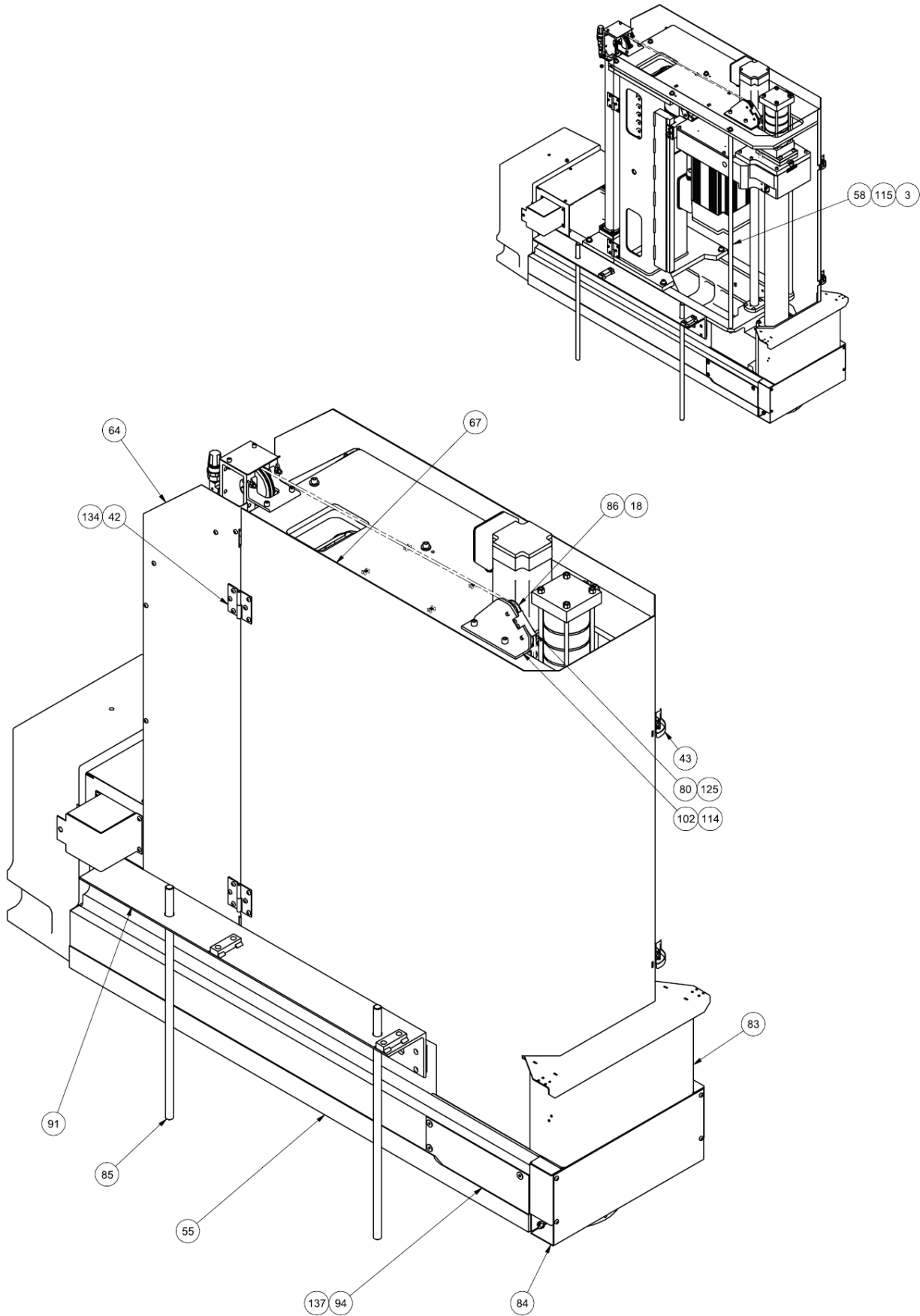

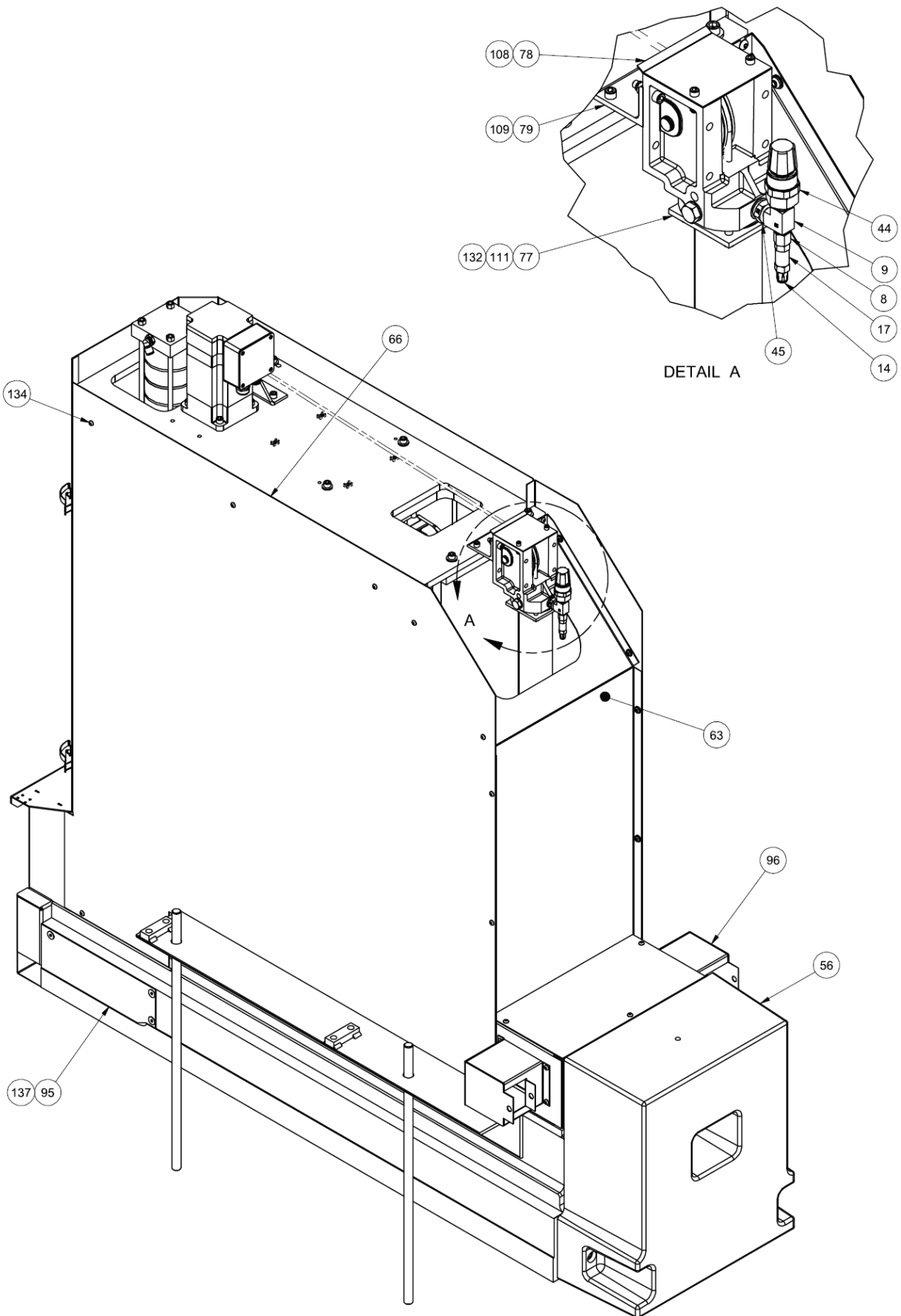

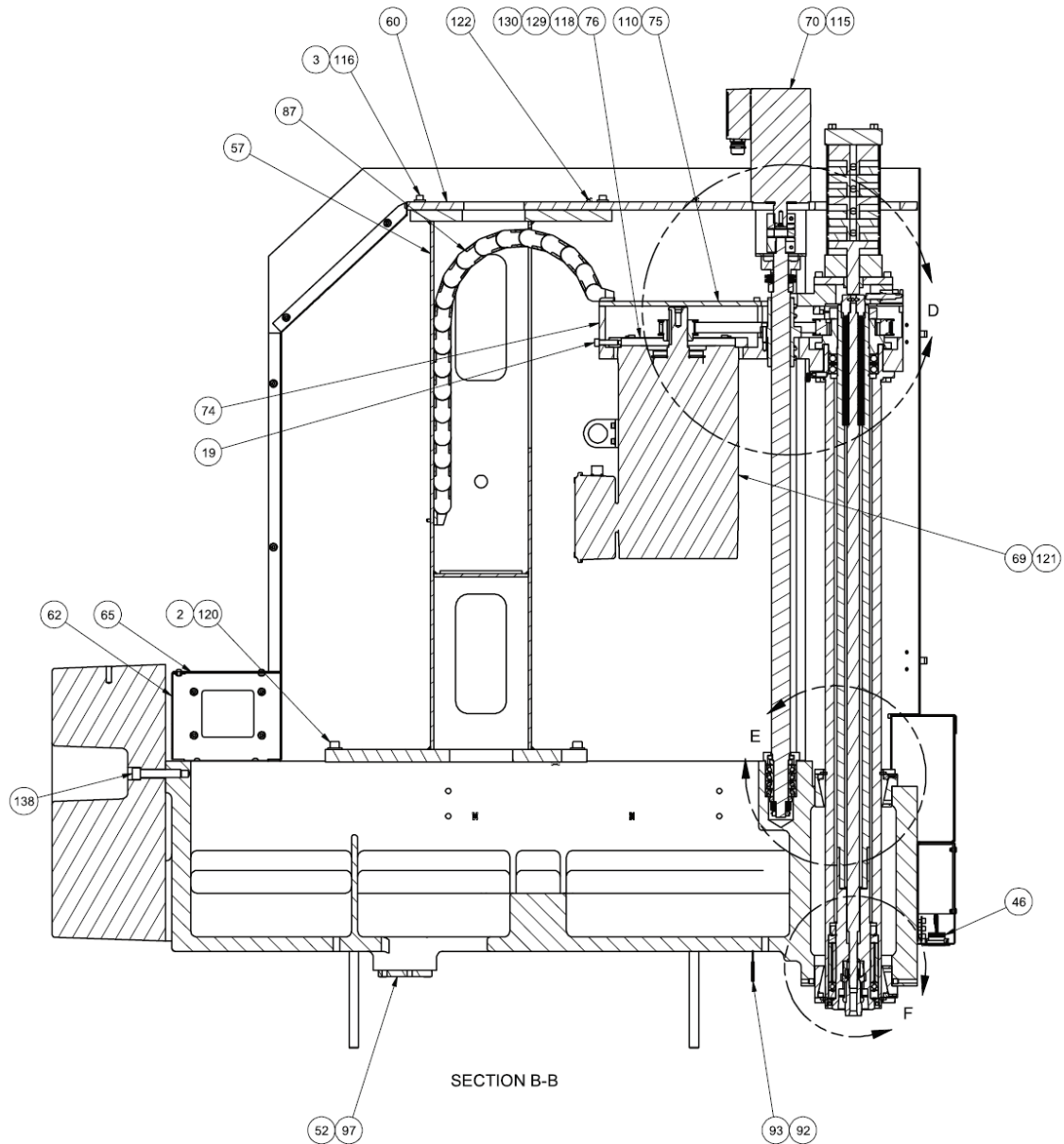
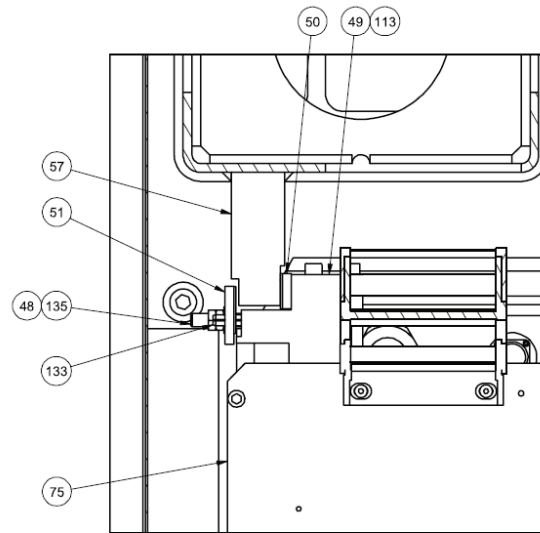

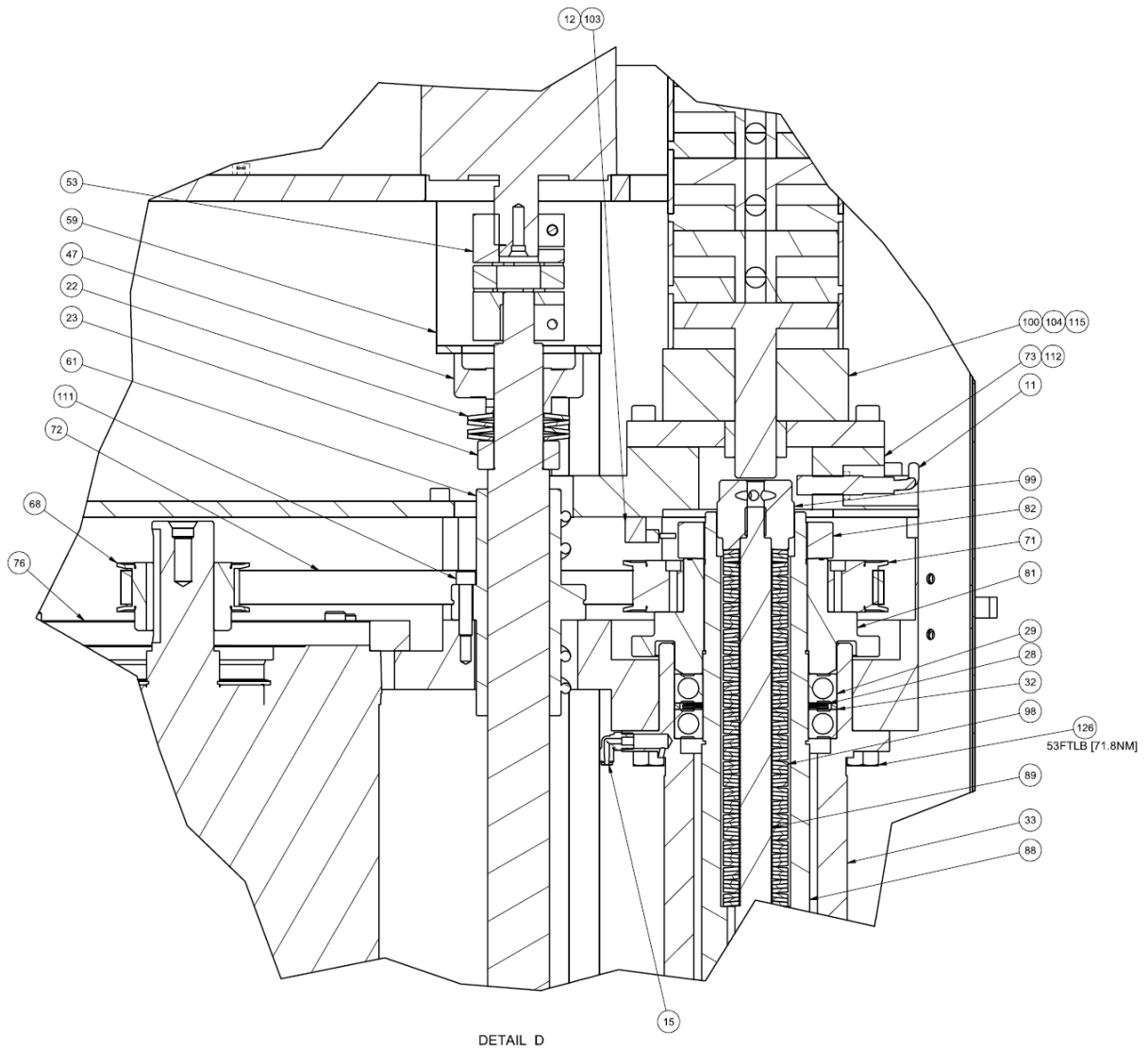

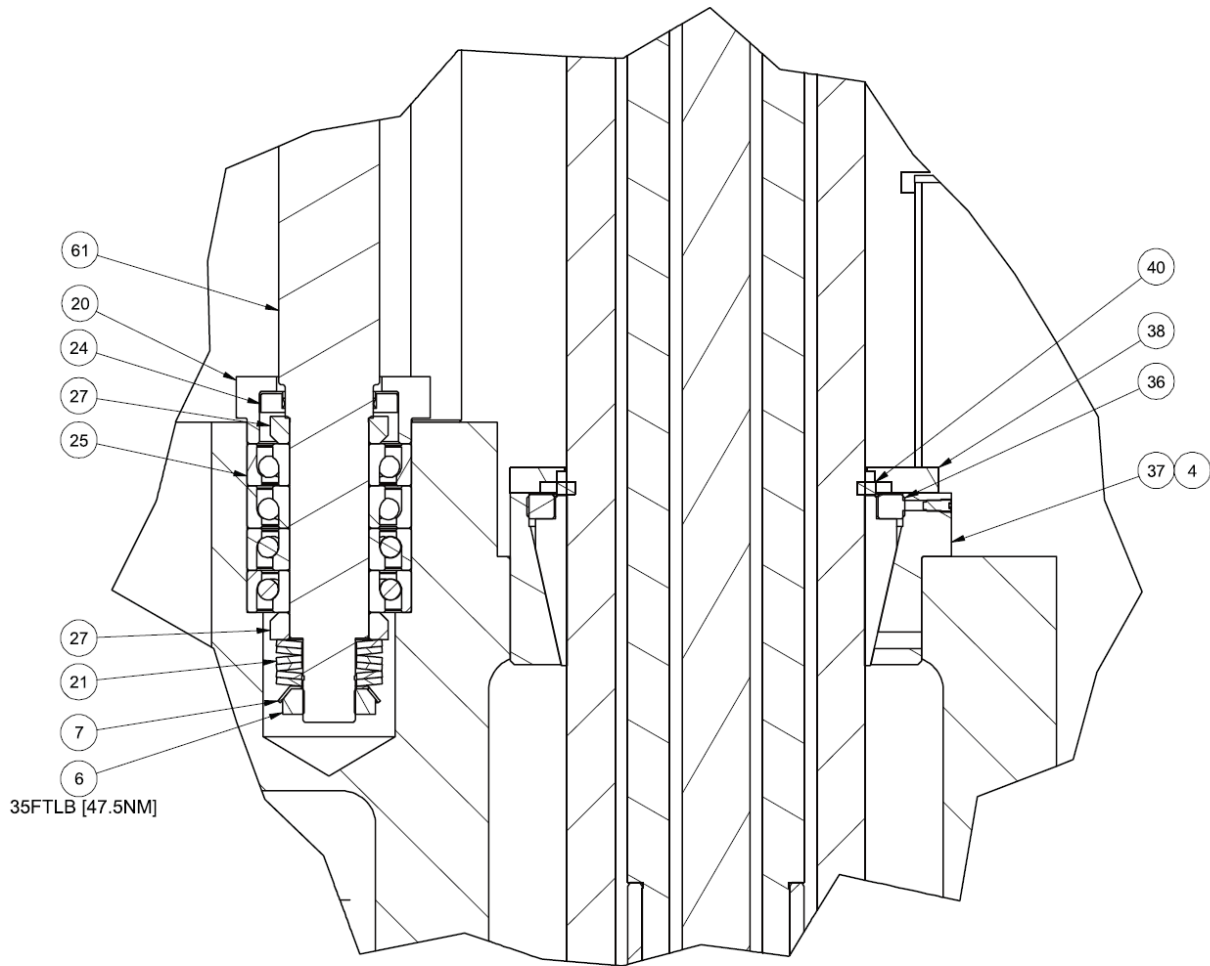

DETAIL E

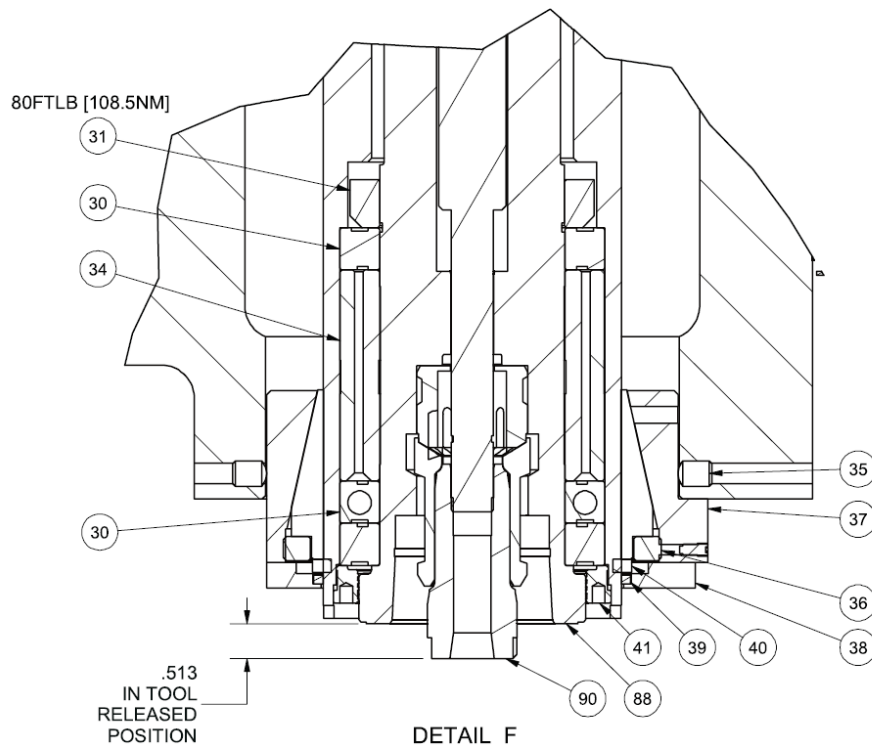

DETAIL F

Parts List			
ITEM	QTY	PART NUMBER	DESCRIPTION
1	1	100-19	WASHER, THRUST
2	4	100-19A	WASHER, HARDENED 17/32" ID
3	7	100-28-18	WASHER, FLAT - CLAMP ARM & WEAR PADS
4	2	100-82-2B	SCREW, SET-BRASS TIPPED (8-32 X 3/8")
5	1	501-27	CAP, OIL TUBE FITTING
6	1	502-10-17	NUT, LOCK
7	1	502-10-18	WASHER, LOCK
8	1	502-11-17L	ADAPTER, #120-B 1/4 TO 1/8" MALE PIPE FITTING
9	1	502-11-17W	TEE, 1/4 FPT X 1/4 MPT
10	1	502-11-59A	TEE, 1/4" NPT X 3/8" TUBE - HSK MACHINES
11	1	502-37-81	SENSOR, PROXIMITY
12	1	514-2-65C	PROXIMITY SWITCH ASSEMBLY- LOWER LIMIT
13	1	514-4-17E	ELBOW, 90 DEGREE MALE - 1/4" POLY X 1/8" NPT
14	1	514-4-17W	FITTING 1/8NPT x 1/4" POLY STRAIGHT
15	2	514-4-18	ELBOW-90 DEGREE 1/8 POLY TO 1/8NPT
16	1	514-4-18A	ELBOW 3/8" TUBE X 1/4" NPT INJECTION OILER
17	1	514-7-58	VALVE, CHECK (SHORT STROKE)
18	2	650-3-66R	SHOULDER SCREW CONROD CAP FIXTURE ASSEMBLY F88S
19	1	650-3-92Y	SCREW, SOCKET HEAD CAP-(3/8-24 X 1 1/2")
20	1	6032E	RETAINER, THRUST BEARING- SPINDLE FEED
21	6	6037A	SPRING, FEED SHAFT & COLUMN BUMPER
22	4	6037C	SPRING, BELLEVILLE VERTICAL BALLSCREW STOP
23	1	6037D	COLLAR, SPACER-VERTICAL BALL SCREW STOP
24	1	6052	SEAL, OIL-UPPER BALLSCREW
25	4	6063	BEARING, ANGULAR CONTACT BALL
26	1	6090B	KEY, SQUARE SPINDLE DRIVE
27	2	6107	RING, SHOULDER-SPINDLE FEED
28	4	6113	SPRING, BELLEVILLE-UPPER BEARING-INNER SPINDLE TAKEUP
29	2	6115A	BEARING, UPPER SPINDLE (BELT DRIVEN F80)
30	1	6116E	BEARING, PRECISION- SPINDLE (SET OF 3)
31	1	6116F	NUT, BEARING-LOWER INNER SPINDLE (SHOELOK)
32	1	6123F	SPACER, OUTER SPINDLE-UPPER HOUSING F80
33	1	6166N	SPINDLE, OUTER-PRECISION BEARING STYLE F88E WITH BELT DRIVE - F100 SERIES
34	1	6172E	SPACER(SET)-PRECISION BEARING SPINDLE
35	4	6219M	SCREW, ADJUSTING-SPINDLE BEARING RETAINER
36	2	6223	NUT, SPINDLE-OUTER
37	2	6225A	CARRIER, LOWER BEARING
38	2	6247A	RETAINER, WIPER-SPINDLE
39	1	6248	WIPER (SQUARE CROSS SECTION "O" RING)
40	2	6249	OILER, FELT-LOWER
41	1	6305D	NUT, THROW BACK RING-PRECISION BEARING SPINDLE
42	2	6320J	HINGE, SPINDLE COVER
43	2	6320M	CLAMP, SPINDLE COVER
44	1	6449	VALVE, RELIEF-COUNTERWEIGHT
45	1	6449A	ADAPTER, BRASS - F106/7/9
46	2	6457N	LED light and Housing
47	1	6759F	BLOCK, FLANGE-SERVO MOTOR
48	2	6760F	SPRING, BELLEVILLE-LINEAR BEARING
49	1	6760J	BRACKET, MOUNTING-LINEAR BEARING
50	1	6760K	BEARING, INNER-LINEAR GUIDE
51	1	6760L	BEARING, OUTER-LINEAR GUIDE
52	4	7242J	THREAD INSERT, CLAMP SHOE
53	1	9001Q	COUPLING ASSEMBLY - EM79/100 FOR Z & Y AXIS
54	1	9005T	VALVE, TOOL RELEASE - F100 HSK MACHINES
55	1	9206B	BASE, SPINDLE (MACHINING) F103, F104, F105
56	1	9206D	COUNTERWEIGHT(MACHINING), SPINDLE BASE , F103, F104, F105
57	1	9207A	TOWER(MACHINING) F103, F104, F105
58	2	9208B	SUPPORT BAR, TOP PLATE - F103, F104, F105
59	1	9208C	VERTICAL BEARING SUPPORT BRACKET - F103/104/105
60	1	9208E	PLATE, TOWER TOP HSK (MACHINING) - F100 SERIES
61	1	9209	BALL SCREW ASSY, Z-AXIS -DIRECT DRIVE (VERTICAL) -F103/104/105
62	1	9213	COVER, BOX-SPINDLE BASE -F103, F104, F105
63	1	9213A	REAR COVER, TOWER -F103, F104, F105
64	1	9213B	COVER, LEFT SIDE REAR -TOWER -F103, F104, F105
65	1	9213C	COVER, LOWER REAR SPINDLE BASE -F103, F104, F105
66	1	9213D	COVER, RIGHT SIDE- TOWER -F103, F104, F105
67	1	9213F	COVER, DOOR-TOWER -F103, F104, F105
68	1	9215B	SPROCKET, DRIVE SPINDLE DRIVE -F103, F104, F105
69	1	9215G	MOTOR, SPINDLE - BISS ENCODER - F100 SERIES
70	1	9215J	Z-AXIS OR EVAC MOTOR (WITH BRAKE) - EM100 & EM69
71	1	9215M	SPROCKET, DRIVEN 60 TOOTH SPINDLE DRIVE (MACHINING) - F103 TO F109
72	1	9215N	BELT, SPINDLE DRIVE - F103 - F109
73	1	9216H	COVER, FRONT UPPER HOUSING (MACHINING) - F100 SERIES WITH HSK SPINDLE
74	1	9216J	HOUSING, UPPER SPINDLE (MACHINING) - EM100
75	1	9216L	COVER, REAR - UPPER HOUSING (MACHINING) EM100
76	1	9216M	PLATE, SPINDLE DRIVE MOTOR MOUNT (MACHINING) - EM100
77	1	9217	COUNTER BALANCE CYLINDER -F103, F104, F105

Parts List			
ITEM	QTY	PART NUMBER	DESCRIPTION
78	1	9217A	GUIDE/COVER, COUNTERBALANCE CYLINDER -F103.F104.F105
79	1	9217B	SUPPORT BRACKET, UPPER CABLE CYLINDER -F103.F104.F105
80	1	9217C	CABLE GUIDE, COUNTERWEIGHT CABLE-F70/F103/F104/F105
81	1	9218	INDEX BUSHING-DRIVEN SPROCKET F103,F104,F105
82	1	9218A	NUT, SPINDLE ADJUSTMENT ,F103.F104.F105
83	1	9222B	FRONT PLATE, SPINDLE BASE -F103.F104.F105
84	1	9222C	LIGHT MOUNT-COVER, SPINDLE BASE -F103.F104.F105
85	4	9227A	HOLD DOWN ROD, SPINDLE BASE - SHIPPING F103/4/5
86	2	9230	PULLEY, CABLE CYLINDER-F103,F104,F105
87	1	9231B	CARRIER,CABLE ASSEMBLY (VERTICAL) -F103/F104/F105
88	1	9233	SPINDLE ASSEMBLY, INNER - F103/4/5 HSK SPINDLE
89	1	9233C	SHAFT, DRAWBAR - F103/4/5 HSK SPINDLE
90	1	10001T	GRIPPER, HSK SPINDLE ASSEMBLY - F107/F109
91	2	10003J	ANGLE PLATE, SPINDLE BASE-F90/F100
92	2	10013C	WIPER PLATE, Y-AXIS-F100 SPINDLE BASE
93	1	10013D	RUBBER WIPER, Y-AXIS-F100 SPINDLE BASE
94	1	10013E	LEFT SIDE COVER, LOWER-SPINDLE BASE-F100
95	1	10013F	RIGHT SIDE COVER, LOWER-SPINDLE BASE-F100
96	2	10015G	BOX ASSEMBLY, CABLE CARRIER MOUNT-F100
97	1	10019	BALLSCREW NUT MOUNT-F100
98	81	10041	BELLEVILLE SPRING, DRAWBAR - HSK SPINDLE
99	1	10041B	NUT, HSK DRAWBAR TOP - F100
100	1	10042B	CYLINDER, DRAWBAR RELEASE - HSK SPINDLE 5 STAGE
101	1	10042F	PACK, VALVE - F106/7/9 HSK
102	1	11017G	BRACKET, DUAL PULLEY COUNTER BALANCE - F79
103	1	11019	BRACKET,SENSOR MOUNT-TOWER-F70
104	2	11042G	CYLINDER, DRAWBAR RELEASE - F100 HSK
105	2	MF-2A	SOCKET HEAD CAPSCRW 8-32 X 3/4"
106	1	MF-11	SOCKET HEAD CAPSCREW 1/4-20 X 3/8"
107	6	MF-12	SOCKET HEAD CAPSCREW 1/4-20 X 1/2"
108	2	MF-15A	S.H.C.S.1/4 - 20 UNC - 7/8
109	2	MF-21	S.H.C.S.5/16 - 18 UNC - 5/8
110	4	MF-22	SOCKET HEAD CAPSCREW 5/16-18 X 3/4"
111	5	MF-24	S.H.C.S.5/16 - 18 UNC - 1 1/4
112	6	MF-25	S.H.C.S.5/16 - 18 UNC - 1 1/2
113	4	MF-28E	SOCKET HEAD CAPSCREW 5/16-18 X 3"
114	6	MF-29	S.H.C.S. 3/8 - 16 UNC - 1/2
115	12	MF-31	S.H.C.S.3/8 - 16 UNC - 1
116	6	MF-32	S.H.C.S.3/8 - 16 UNC - 1 1/4
117	12	MF-33	SOCKET HEAD CAPSCREW 3/8-16 X 1 1/2"
118	4	MF-34	SOCKET HEAD CAPSCREW 3/8-16 X 2"
119	1	MF-39C	SOCKET HEAD CAPSCREW 7/16-14 X 1 1/4"
120	4	MF-44	S.H.C.S.1/2 - 13 UNC - 1 1/2
121	4	MF-44A	SOCKET HEAD CAPSCREW 1/2-13 X 1 3/4"
122	10	MF-76	Socket Flat Head 8-32 UNC x 0.375
123	4	MF-79	SOCKET FLAT HEAD SCREW 10-24 X 1/2"
124	8	MF-79A	SOCKET FLAT HEAD SCREW 10-24 X 5/8"
125	2	MF-87	Socket Button Head10 - 24 x 1/4
126	5	MF-149	HEX BOLT 1/2-13 X 1 1/4"
127	4	MF-164	HEX JAM NUTS 3/8-16
128	6	MF-179	FLAT WASHERS 1/4"
129	4	MF-179A	FLAT WASHERS 3/8"
130	4	MF-184A	LOCK WASHERS 3/8"
131	2	MF-186A	NYLOCK NUTS 1/4-20
132	2	MF-187	NYLOCK NUTS 5/16-18 NC
133	2	MF-228	ROLL PINS 5/16 X 1 1/2"
134	52	MF-248	Socket Button Head1/4 - 20 x 3/8
135	1	MF-1000	SOCKET SET SCREW CUP POINT 3/8-16 X 2"
136	2	-	SOCKET FLAT HEAD SCREW 5/16-18 X 3/4"
137	6	-	SOCKET FLAT HEAD SCREW 3/8-16 X 5/8"
138	3	-	S.H.C.S.5/8 - 11 UNC - 3 1/4

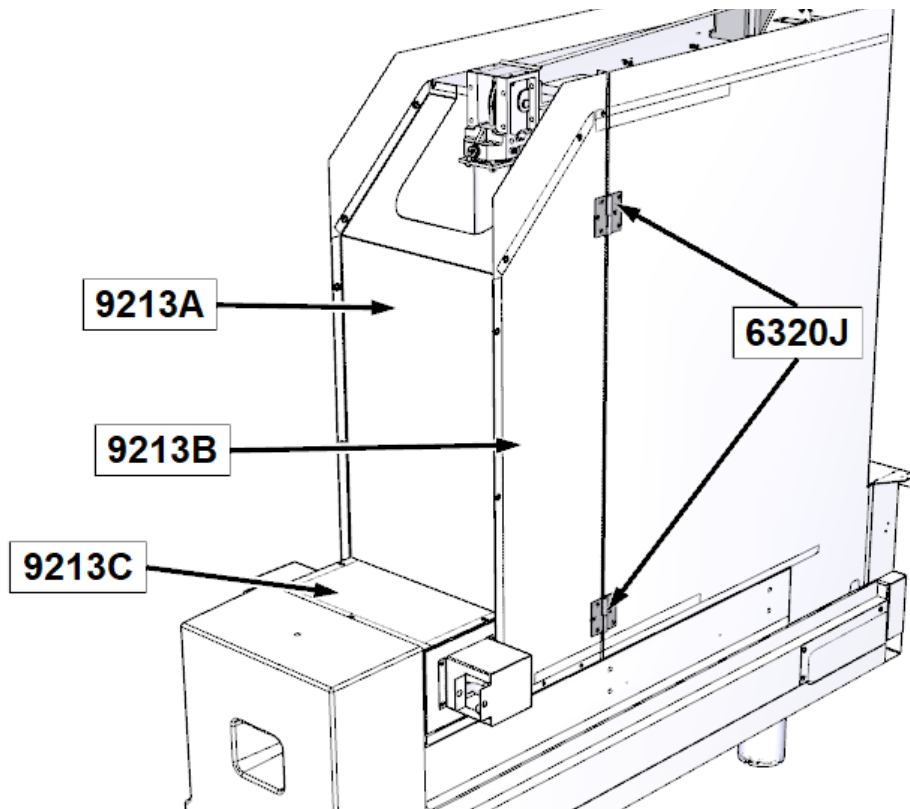
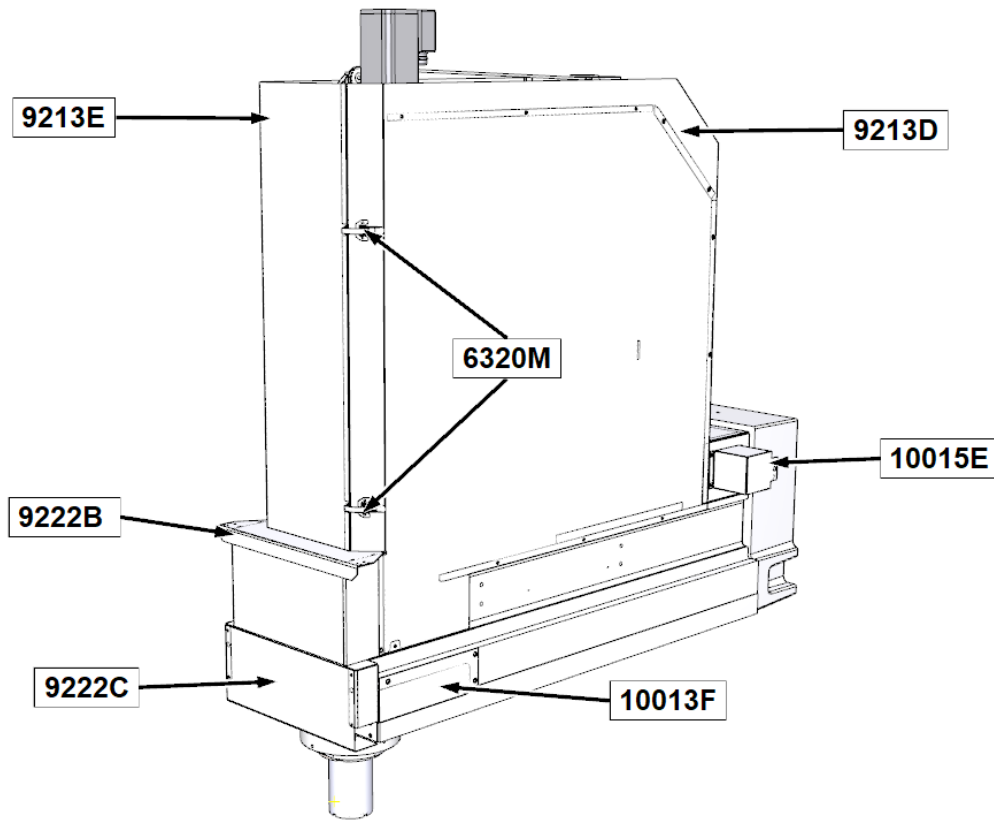

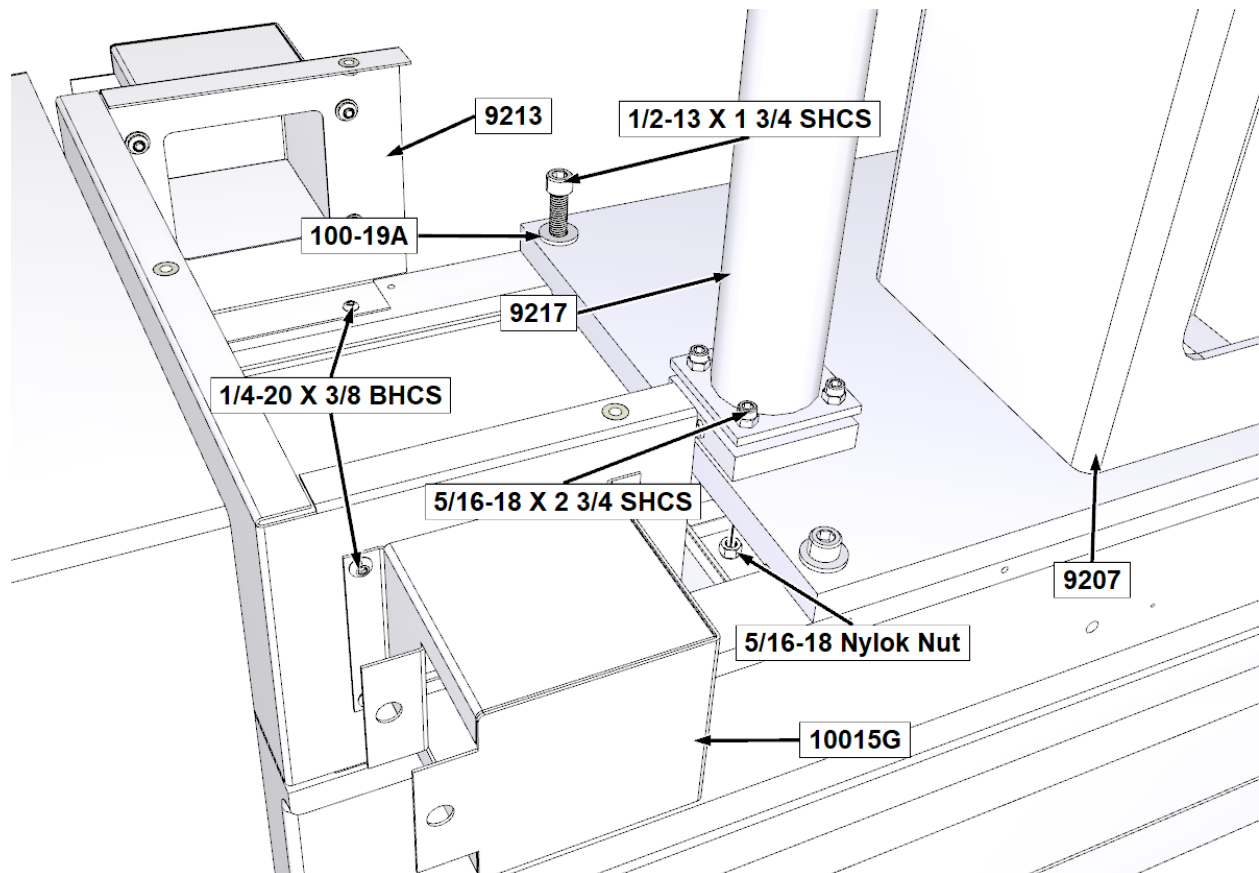
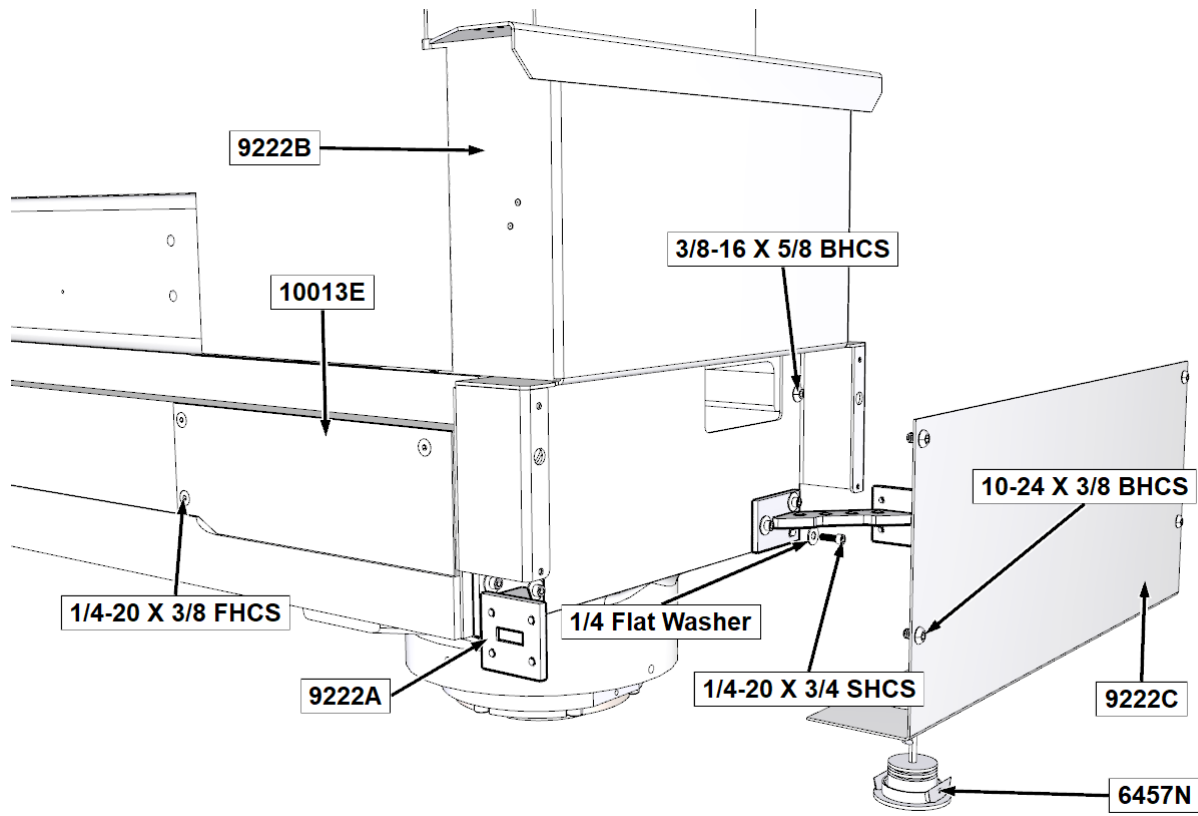

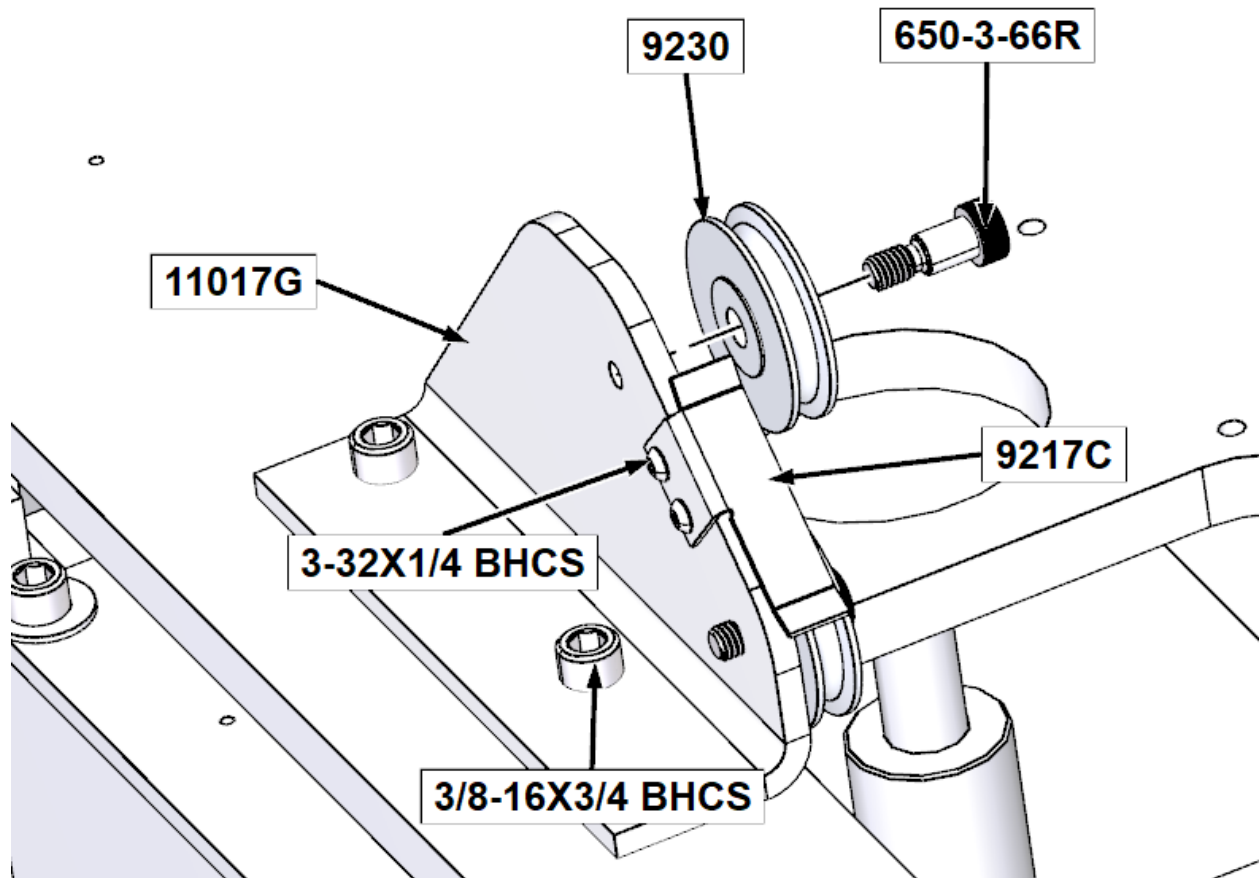
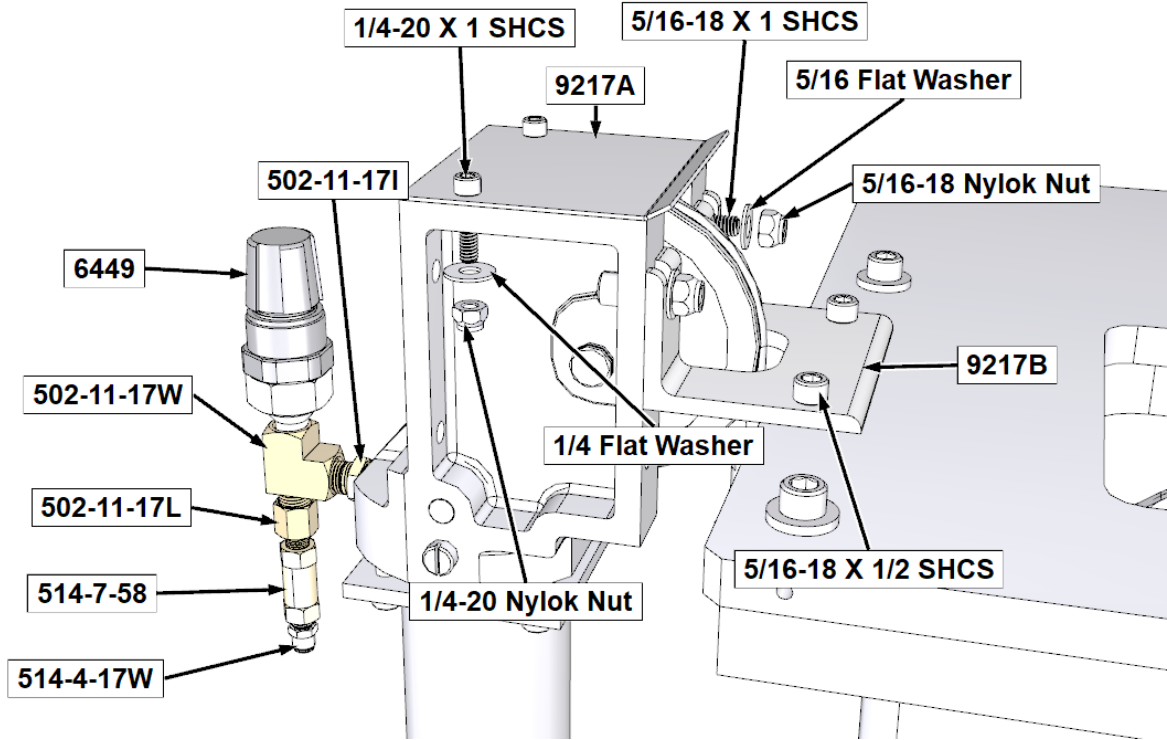

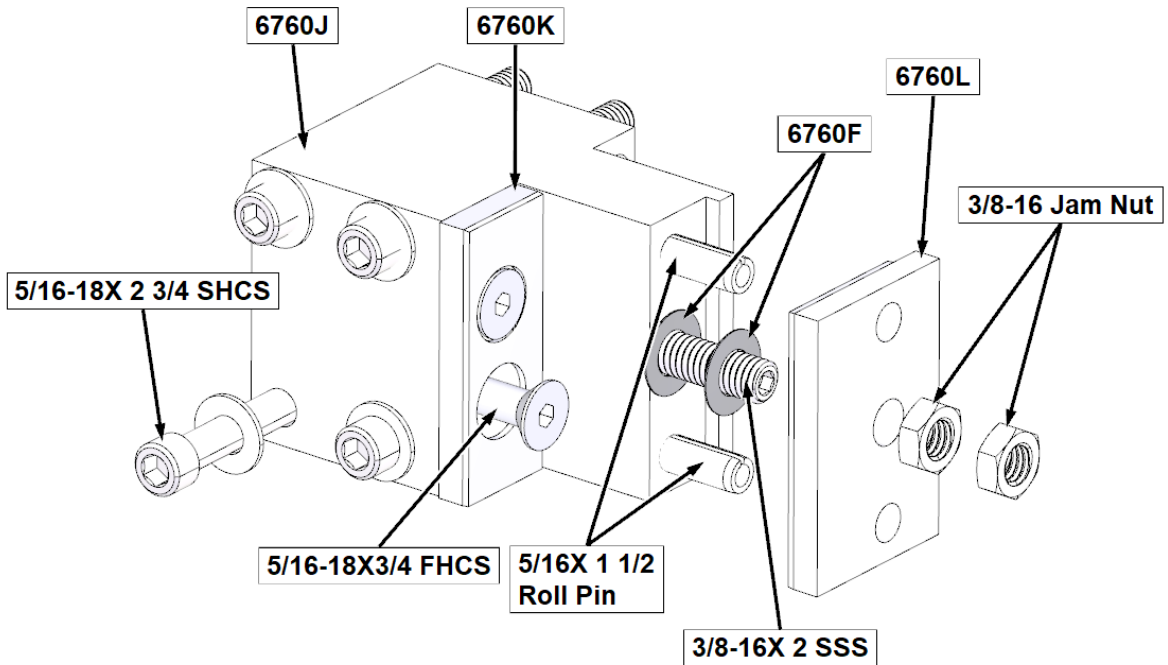
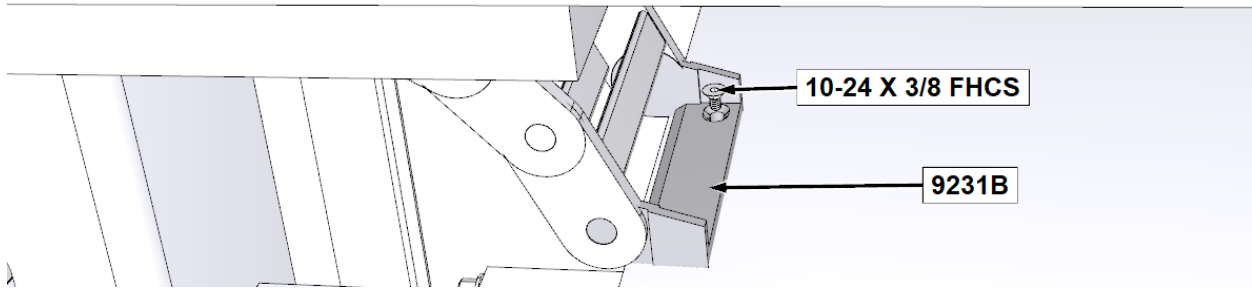
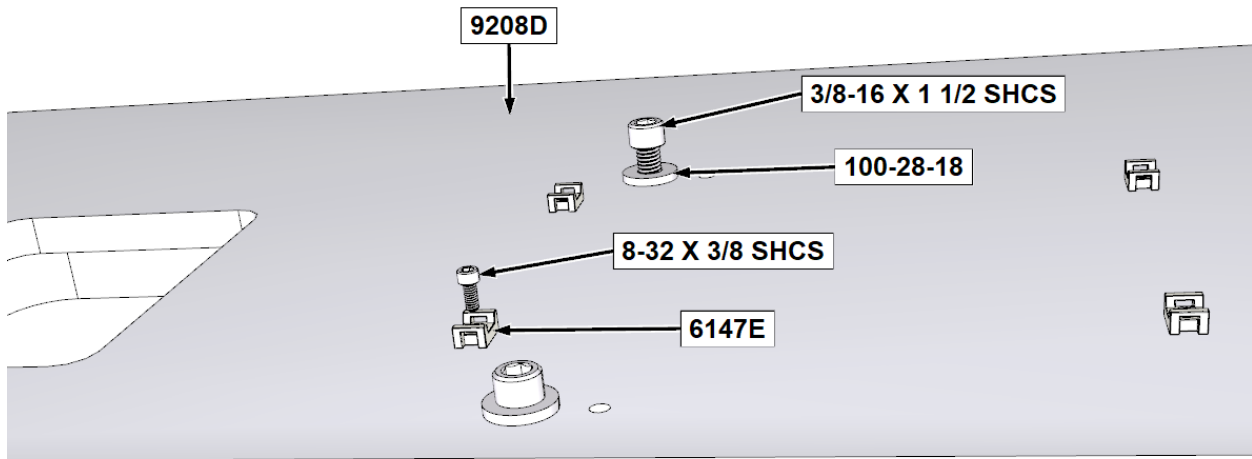

Z-Axis Drive Assembly Parts

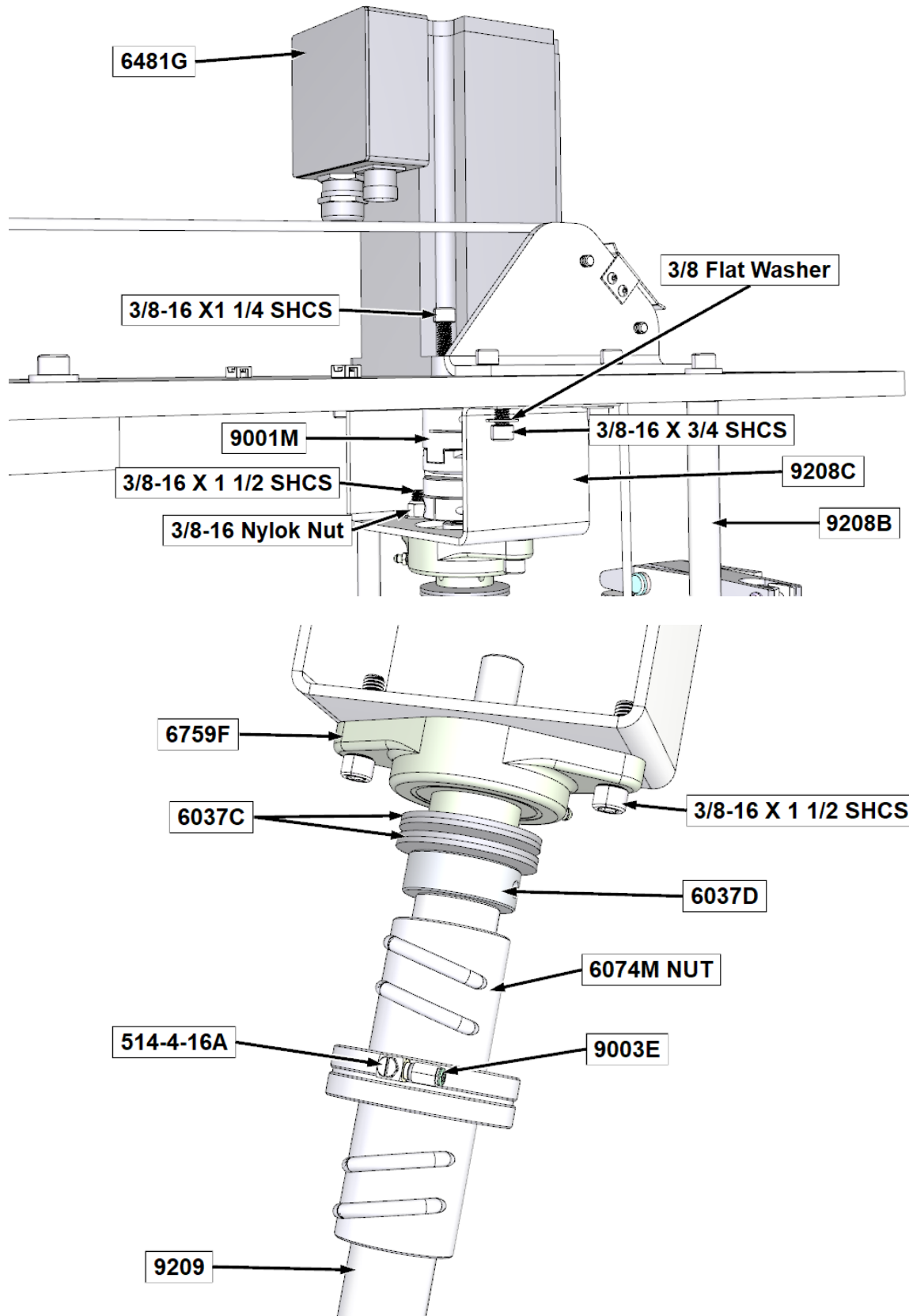

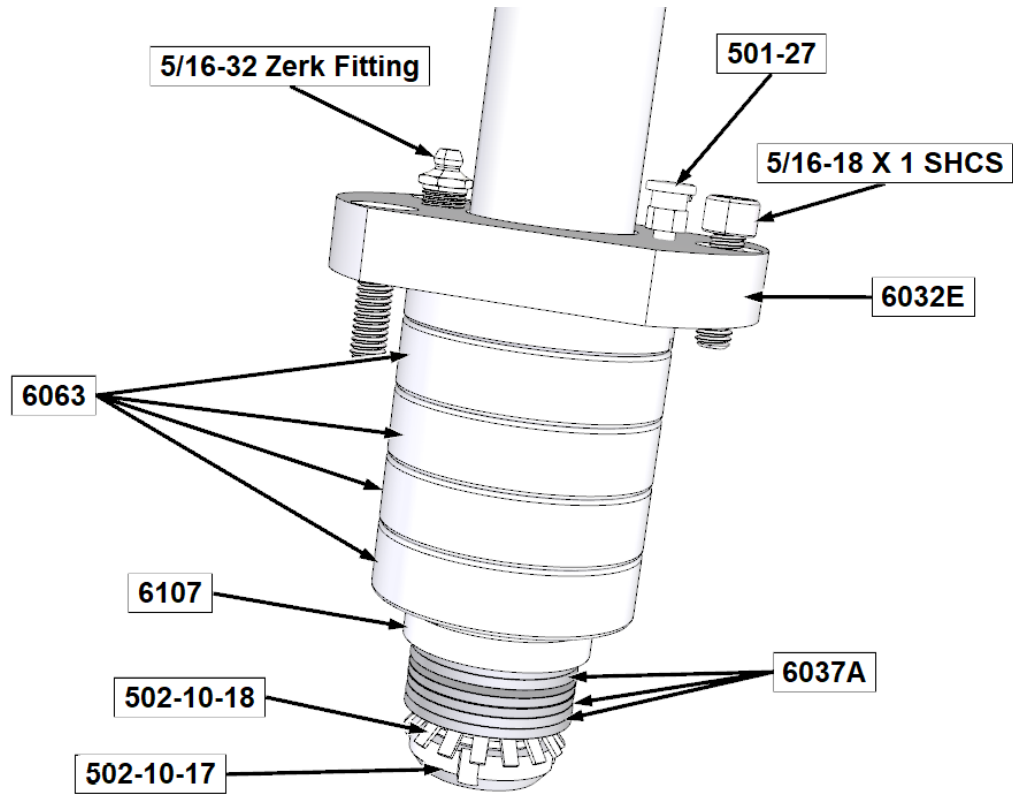

Chip Shield Parts

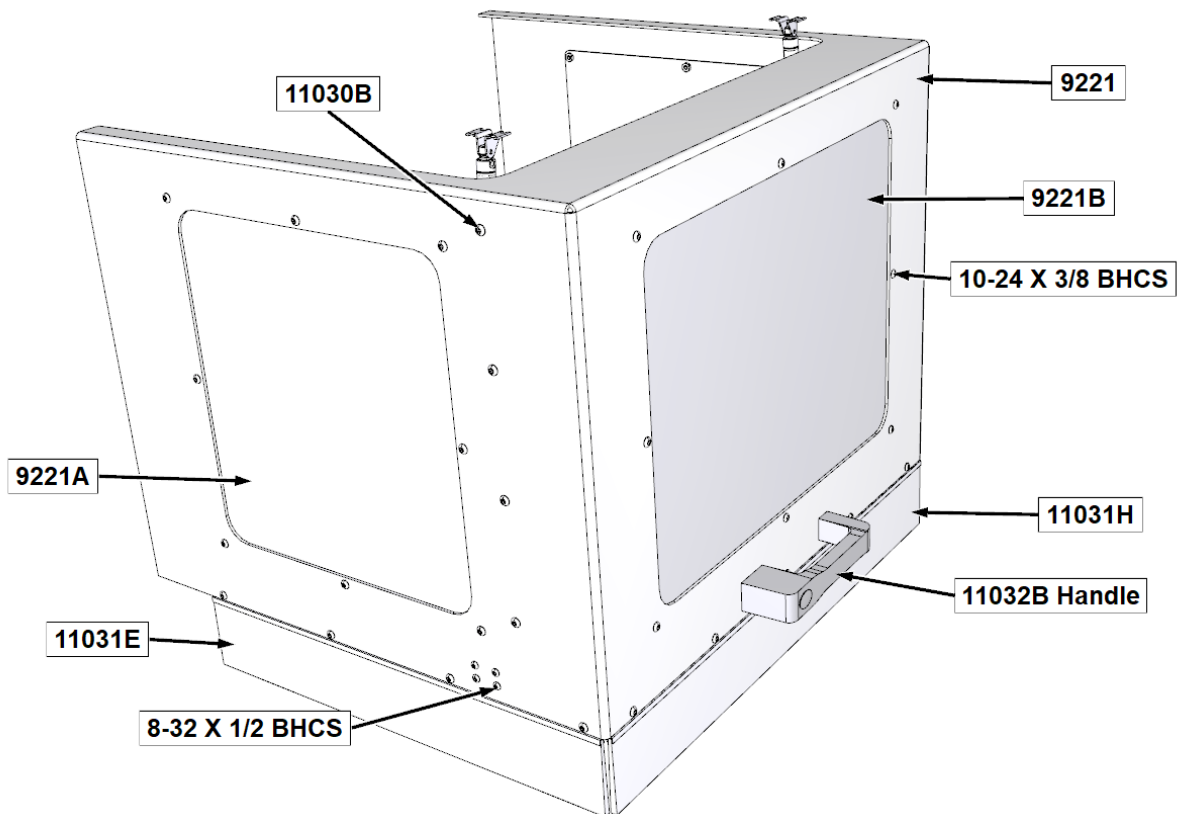

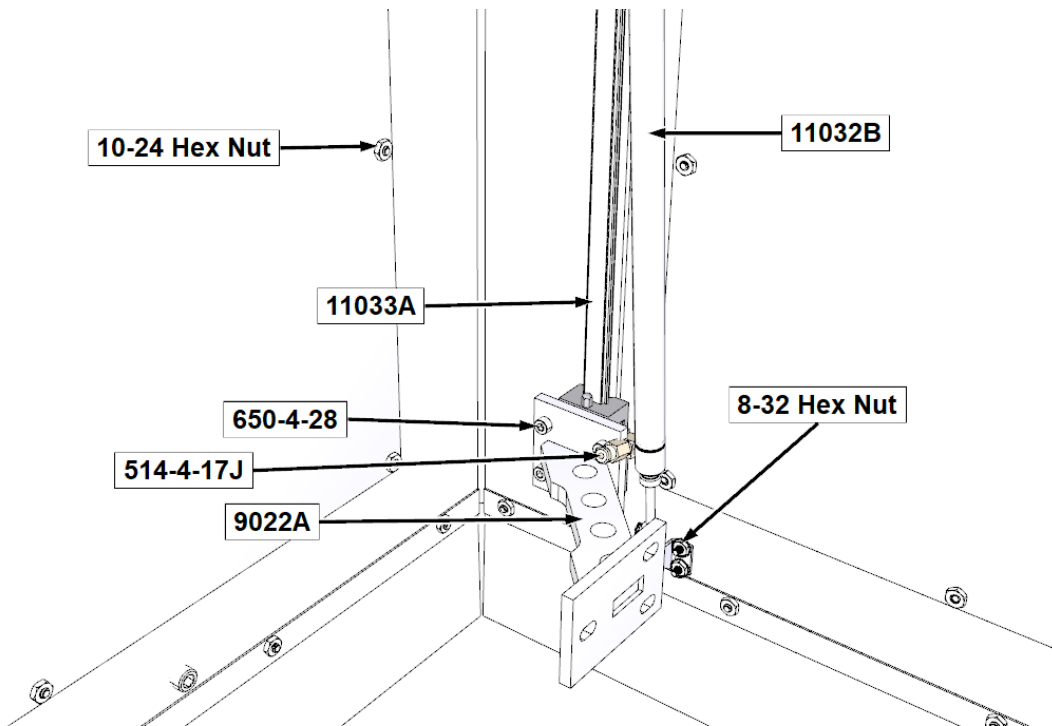

Electrical Enclosure Parts

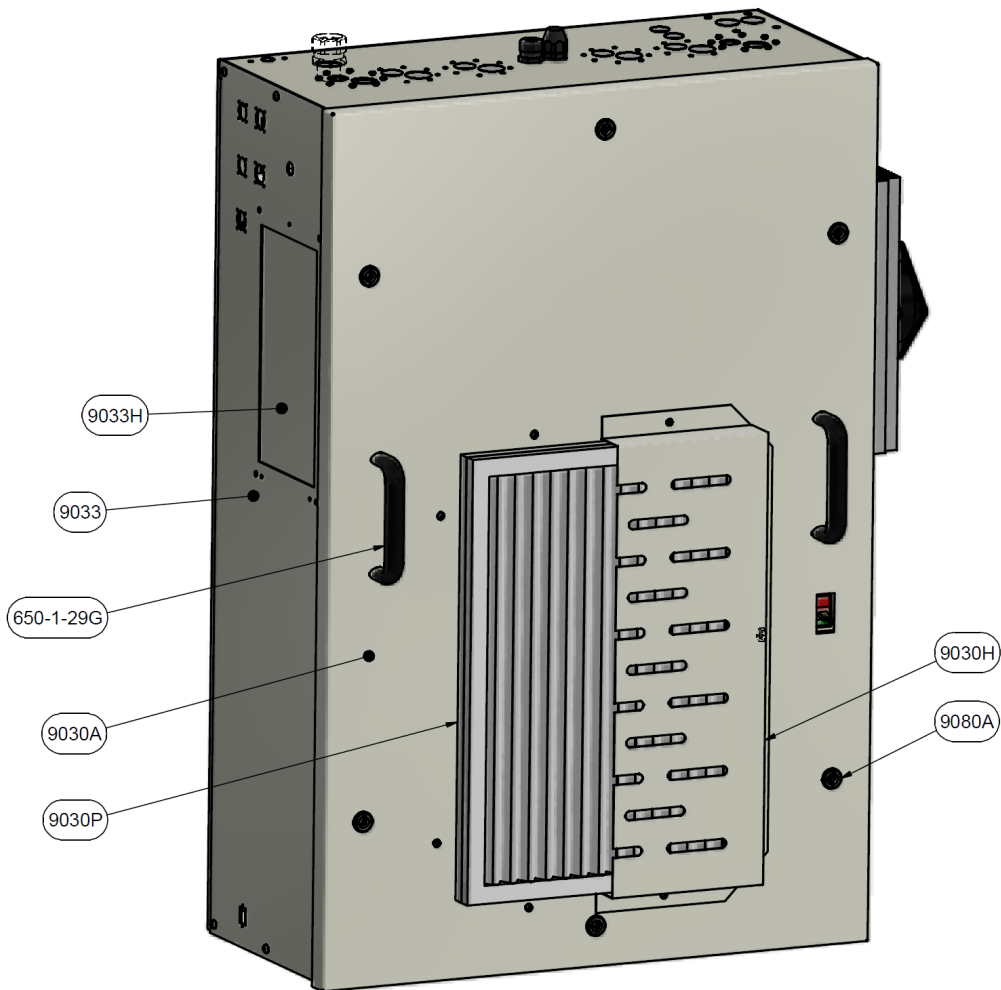

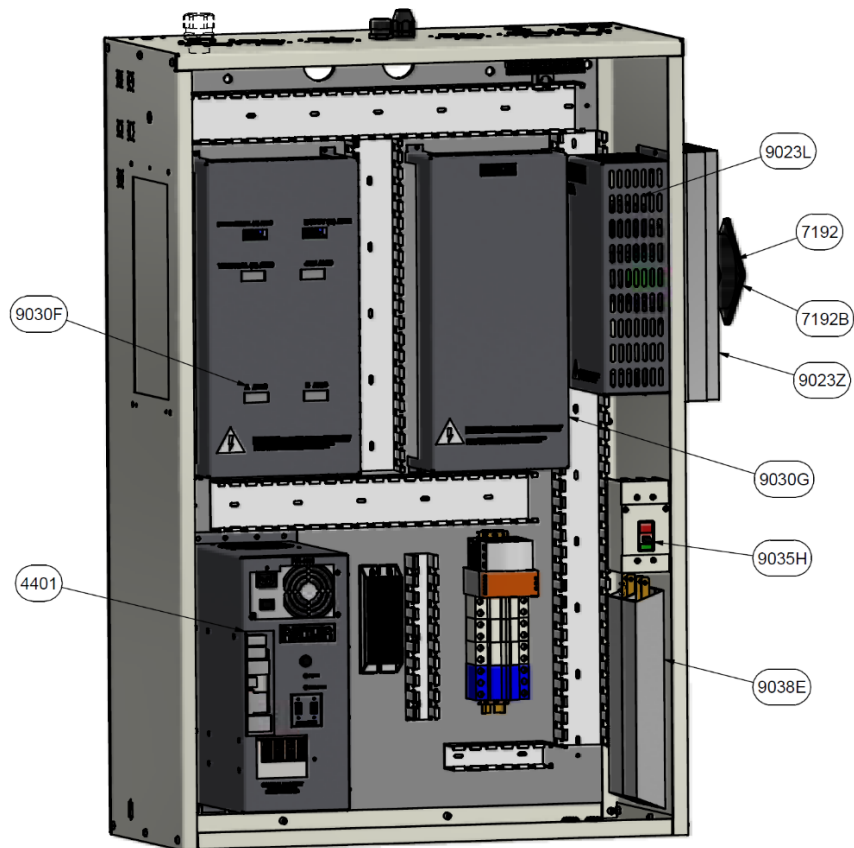
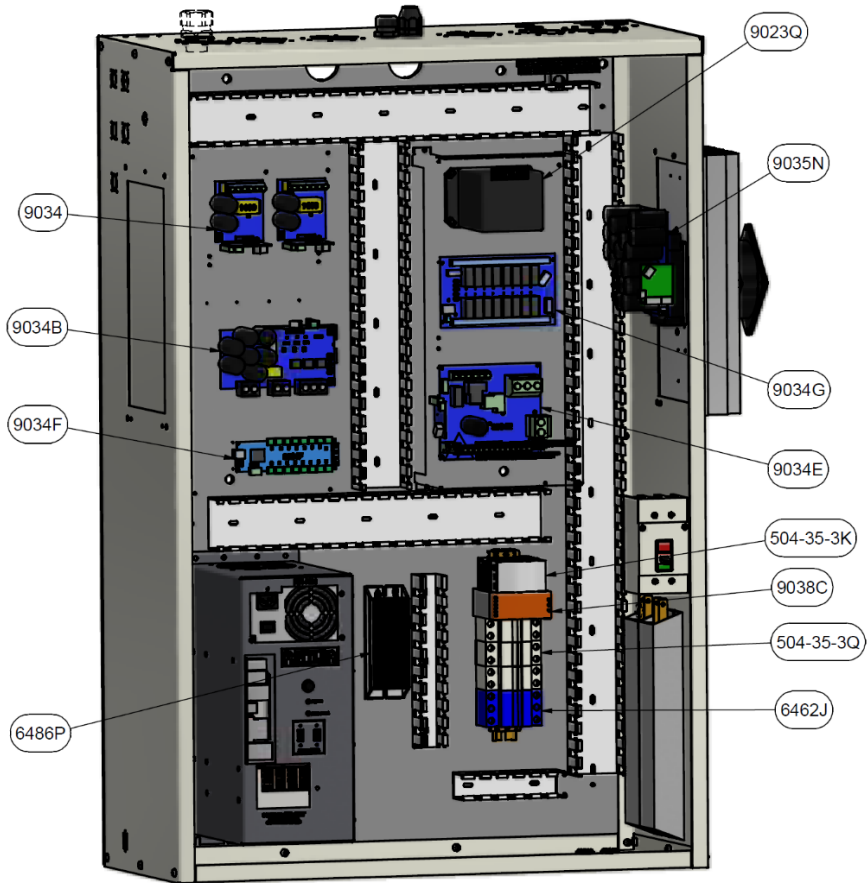

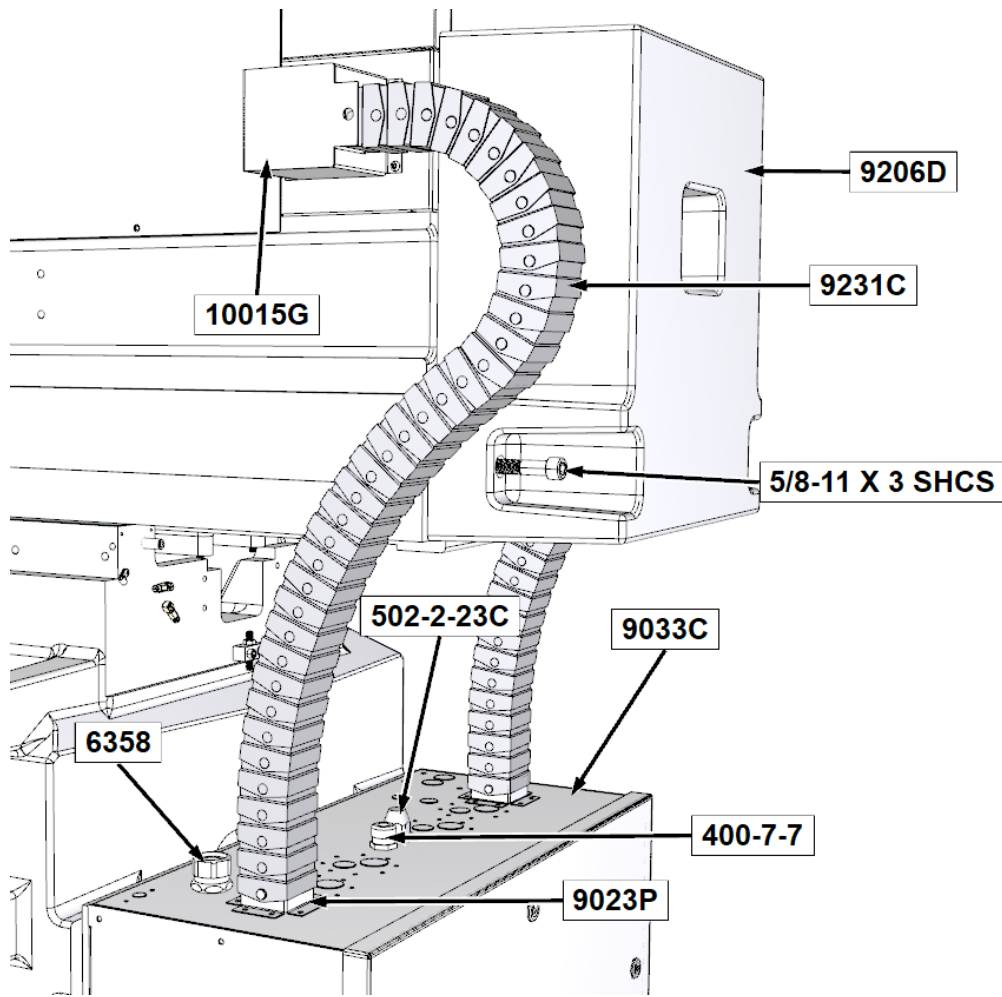

Spindle Housing Assembly Parts

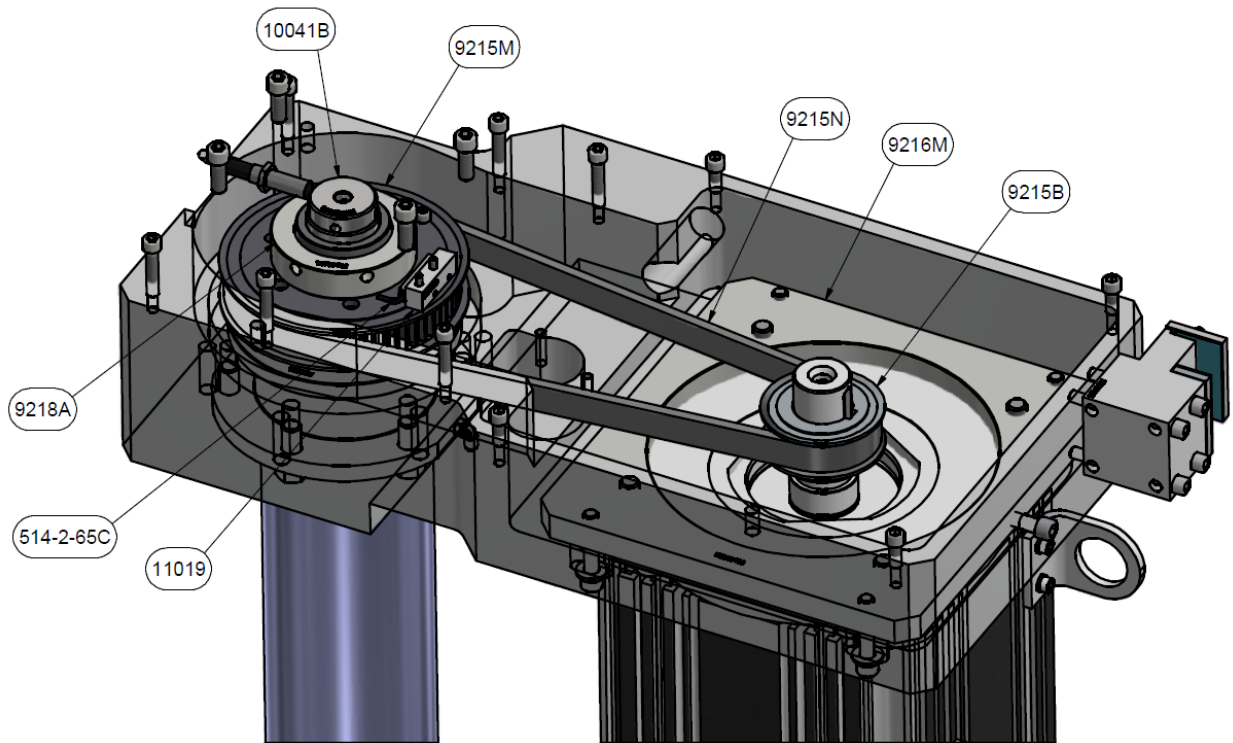
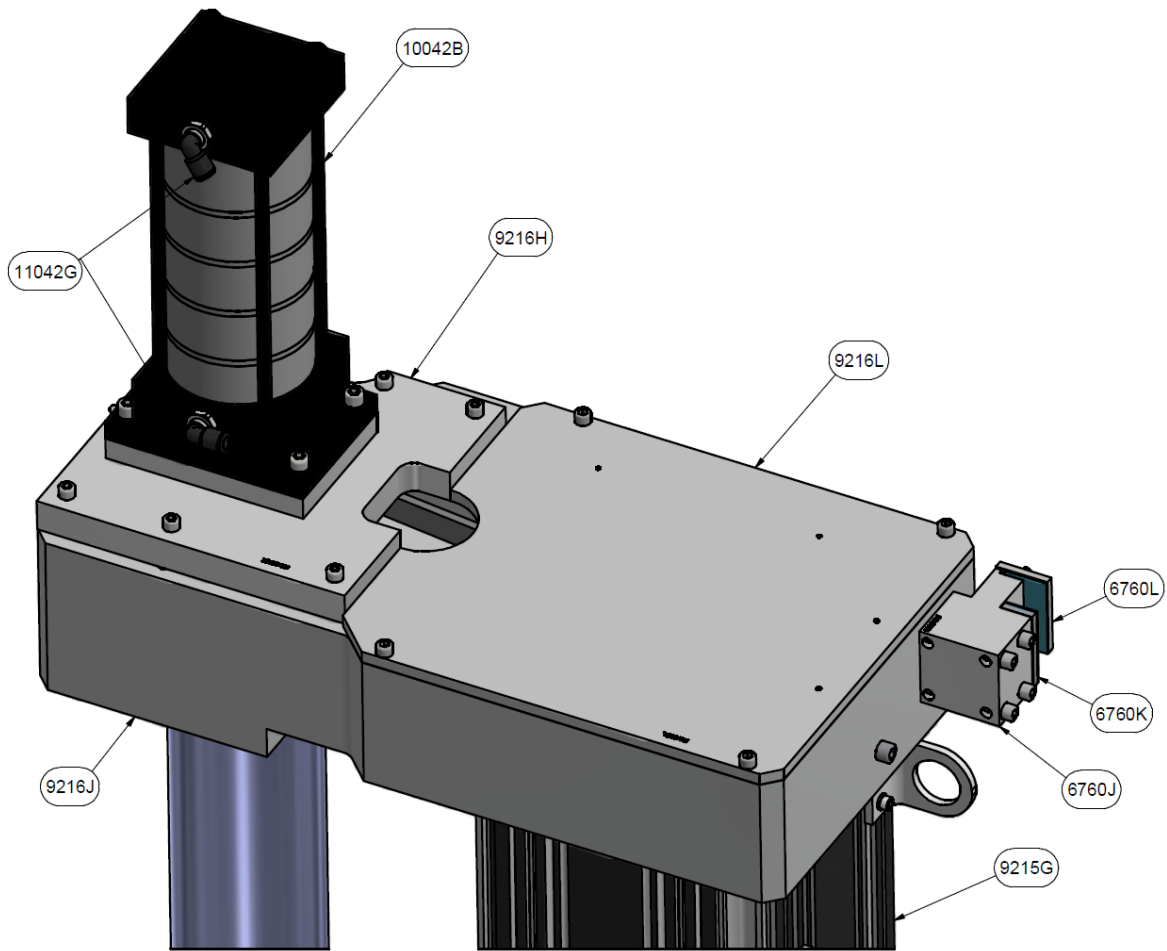

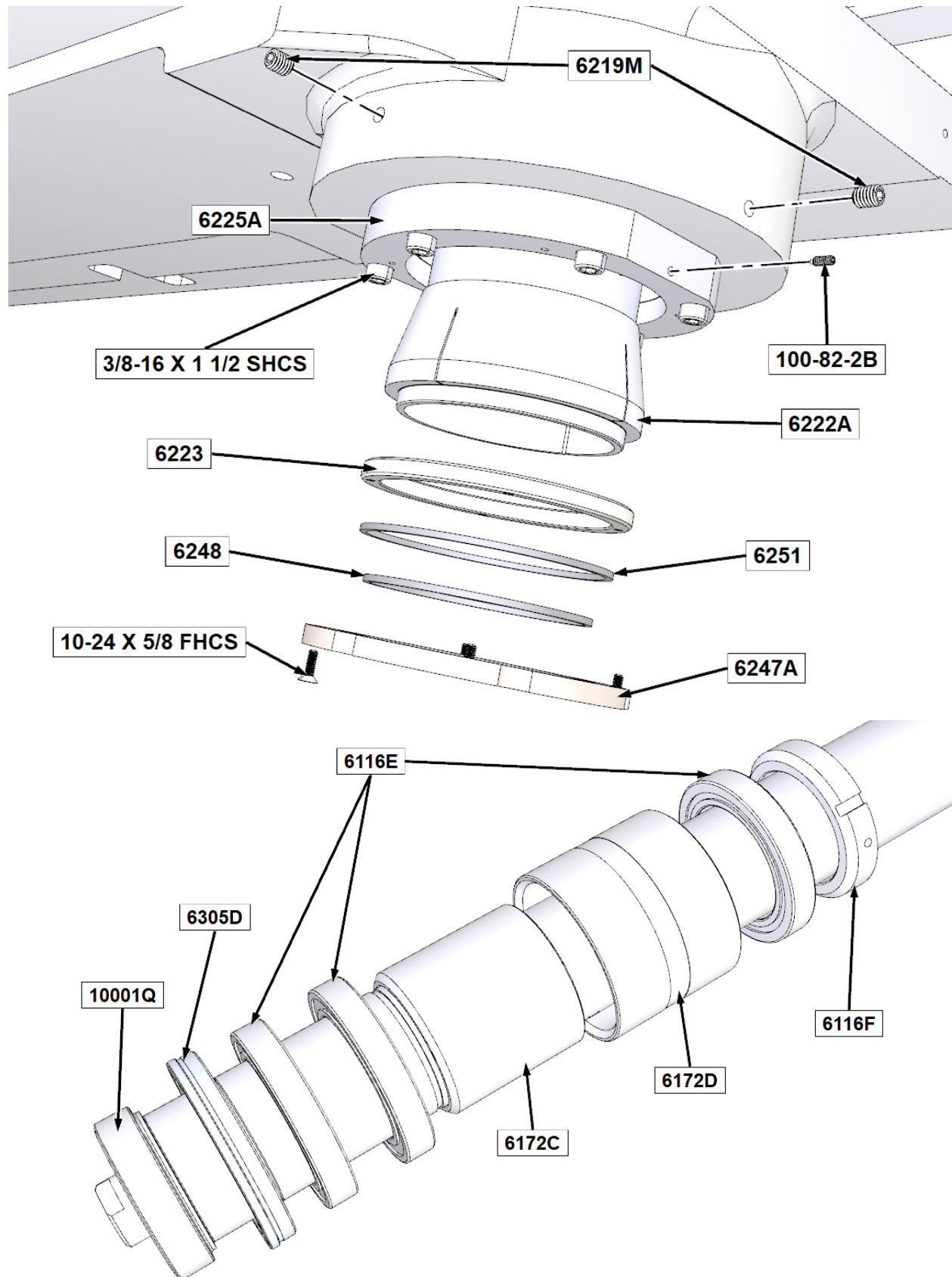

Manual Tool Rack Assembly

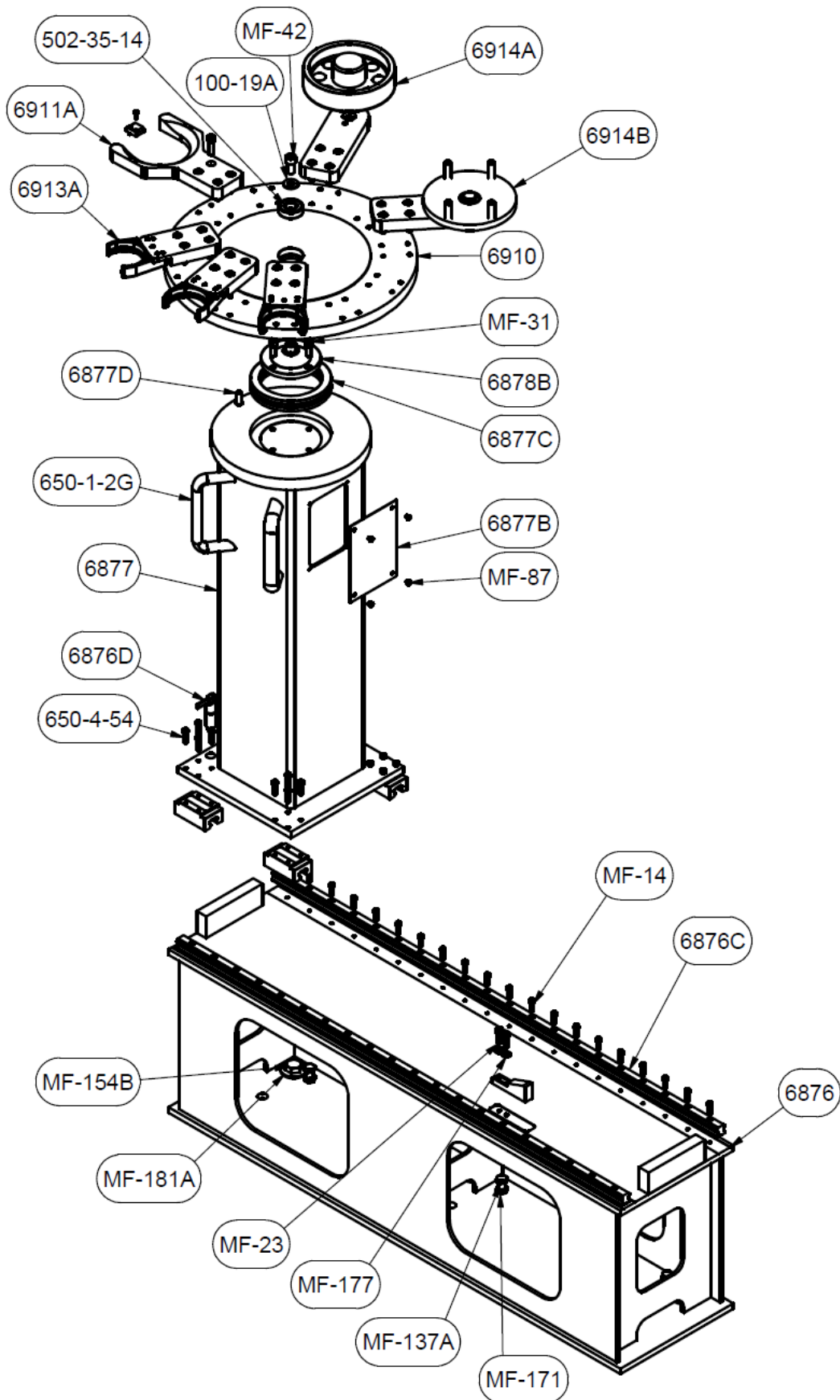

SDS

The Safety Data Sheets list shown in this section are the substances and materials that an operator is most likely to come in contact with while using this machine.

Other substances and materials are used in the manufacture, testing, and shipping of this machine. A complete list of the Safety Data Sheets of substances and materials used by Rottler Manufacturing during manufacturing, testing, and shipping is located on the Manual flash drive shipped with the machine. Safety Data Sheets are also located on the company web site: <http://www.rottlermfg.com/documentation.php>

- 1. Mobil Vactra Oil #2**
- 2. Mobil Polyrex EP2**

Product Name: Mobil Vactra Oil No. 2

Revision Date: 30 Aug 2018

Page 1 of 8



SAFETY DATA SHEET

SECTION 1 PRODUCT AND COMPANY IDENTIFICATION

PRODUCT

Product Name: MOBIL VACTRA OIL NO. 2
Product Description: Base Oil and Additives
Product Code: 201560901015, 600494-85
Intended Use: Lubricant

COMPANY IDENTIFICATION

Supplier: East Coast Lubes Pty Ltd (Queensland and Northern Territory)
 A.B.N. 37 117 203 611
 Cnr North and Mort Streets
 Toowoomba, Queensland 4350, Australia

24 Hour Emergency Telephone 1300 131 001
Supplier General Contact 1800 069 019

Supplier: Southern Cross Lubes (Victoria and Tasmania, New South Wales and Australian Capital Territory)
 58-66 Ajax Road
 Altona, Victoria 3018, Australia

24 Hour Emergency Telephone 1300 131 001
Product Technical Information 1300 466 245
Supplier General Contact 1300 552 861

Supplier: Perkal Pty Ltd Trading as Statewide Oil (Western Australia)
 A.B.N. 43 009 283 363
 14 Beete Street
 Welshpool, Western Australia 6106 Australia

24 Hour Emergency Telephone (8:00am to 4:30pm Mon to Fri) 1300 919 904
Product Technical Information (08) 9350 6777
Supplier General Contact (08) 9350 6777

Supplier: Perkal Pty Ltd Trading as Statewide Oil (South Australia)
 A.B.N. 43 009 283 363
 6-10 Streiff Rd
 Wingfield, South Australia 5013 Australia

24 Hour Emergency Telephone (8:00am to 4:30pm Mon to Fri) 1300 919 904
Product Technical Information (08) 8359 8995
Supplier General Contact (08) 8359 8995

Product Name: Mobil Vactra Oil No. 2

Revision Date: 30 Aug 2018

Page 2 of 8



SECTION 2 HAZARDS IDENTIFICATION

This material is not hazardous according to regulatory guidelines (see (M)SDS Section 15).

Contains: PHOSPHORIC ACID ESTERS, AMINE SALT May produce an allergic reaction.

Other Hazard Information:

Physical / Chemical Hazards:

No significant hazards.

Health Hazards:

High-pressure injection under skin may cause serious damage. Excessive exposure may result in eye, skin, or respiratory irritation.

Environmental Hazards:

No significant hazards.

NOTE: This material should not be used for any other purpose than the intended use in Section 1 without expert advice. Health studies have shown that chemical exposure may cause potential human health risks which may vary from person to person.

SECTION 3 COMPOSITION / INFORMATION ON INGREDIENTS

This material is defined as a mixture.

Reportable Hazardous Substance(s) or Complex Substance(s)

Name	CAS#	Concentration	GHS Hazard Codes
2,6-DI-BUTYL-P-CRESOL	128-37-0	0.1 - < 1%	H400 (M factor 1) H410 (M factor 1)
PHOSPHORIC ACID ESTERS, AMINE SALT	Confidential	0.1 - < 1%	H227, H302, H317, H318, H401, H411

* All concentrations are percent by weight unless ingredient is a gas. Gas concentrations are in percent by volume. Other ingredients determined not to be hazardous up to 100%.

SECTION 4 FIRST AID MEASURES

INHALATION

Remove from further exposure. For those providing assistance, avoid exposure to yourself or others. Use adequate respiratory protection. If respiratory irritation, dizziness, nausea, or unconsciousness occurs, seek immediate medical assistance. If breathing has stopped, assist ventilation with a mechanical device or use mouth-to-mouth resuscitation.

SKIN CONTACT

Wash contact areas with soap and water. If product is injected into or under the skin, or into any part of the body, regardless of the appearance of the wound or its size, the individual should be evaluated immediately a physician as a surgical emergency. Even though initial symptoms from high pressure injection may be minimal or absent, early surgical treatment within the first few hours may significantly reduce the ultimate extent of injury.

EYE CONTACT

Flush thoroughly with water. If irritation occurs, get medical assistance.

INGESTION

First aid is normally not required. Seek medical attention if discomfort occurs.

NOTE TO PHYSICIAN

None

Product Name: Mobil Vacra Oil No. 2

Revision Date: 30 Aug 2018

Page 3 of 8

**SECTION 5 FIRE FIGHTING MEASURES****EXTINGUISHING MEDIA**

Appropriate Extinguishing Media: Use water fog, foam, dry chemical or carbon dioxide (CO₂) to extinguish flames.

Inappropriate Extinguishing Media: Straight streams of water

FIRE FIGHTING

Fire Fighting Instructions: Evacuate area. Prevent run-off from fire control or dilution from entering streams, sewers or drinking water supply. Fire-fighters should use standard protective equipment and in enclosed spaces, self-contained breathing apparatus (SCBA). Use water spray to cool fire exposed surfaces and to protect personnel.

Hazardous Combustion Products: Aldehydes, Incomplete combustion products, Oxides of carbon, Smoke, Fume, Sulphur oxides

FLAMMABILITY PROPERTIES

Flash Point [Method]: >205°C (401°F) [ASTM D-92]

Flammable Limits (Approximate volume % in air): LEL: 0.9 UEL: 7.0

Autoignition Temperature: N/D

SECTION 6 ACCIDENTAL RELEASE MEASURES**NOTIFICATION PROCEDURES**

In the event of a spill or accidental release, notify relevant authorities in accordance with all applicable regulations.

PROTECTIVE MEASURES

Avoid contact with spilled material. See Section 5 for firefighting information. See the Hazard Identification Section for Significant Hazards. See Section 4 for First Aid Advice. See Section 8 for advice on the minimum requirements for personal protective equipment. Additional protective measures may be necessary, depending on the specific circumstances and/or the expert judgment of the emergency responders.

For emergency responders: Respiratory protection: respiratory protection will be necessary only in special cases, e.g., formation of mists. Half-face or full-face respirator with filter(s) for dust/organic vapor or Self Contained Breathing Apparatus (SCBA) can be used depending on the size of spill and potential level of exposure. If the exposure cannot be completely characterized or an oxygen deficient atmosphere is possible or anticipated, SCBA is recommended. Work gloves that are resistant to hydrocarbons are recommended. Gloves made of polyvinyl acetate (PVA) are not water-resistant and are not suitable for emergency use. Chemical goggles are recommended if splashes or contact with eyes is possible. Small spills: normal antistatic work clothes are usually adequate. Large spills: full body suit of chemical resistant, antistatic material is recommended.

SPILL MANAGEMENT

Land Spill: Stop leak if you can do so without risk. Recover by pumping or with suitable absorbent.

Water Spill: Stop leak if you can do so without risk. Confine the spill immediately with booms. Warn other shipping. Remove from the surface by skimming or with suitable absorbents. Seek the advice of a specialist before using dispersants.

Water spill and land spill recommendations are based on the most likely spill scenario for this material; however, geographic conditions, wind, temperature, (and in the case of a water spill) wave and current direction and speed may greatly influence the appropriate action to be taken. For this reason, local experts should be consulted. Note: Local regulations may prescribe or limit action to be taken.

ENVIRONMENTAL PRECAUTIONS

Large Spills: Dyke far ahead of liquid spill for later recovery and disposal. Prevent entry into waterways, sewers, basements or confined areas.

Product Name: Mobil Vacra Oil No. 2

Revision Date: 30 Aug 2018

Page 4 of 8



SECTION 7 HANDLING AND STORAGE

HANDLING

Prevent small spills and leakage to avoid slip hazard. Material can accumulate static charges which may cause an electrical spark (ignition source). When the material is handled in bulk, an electrical spark could ignite any flammable vapors from liquids or residues that may be present (e.g., during switch-loading operations). Use proper bonding and/or earthing procedures. However, bonding and earthing may not eliminate the hazard from static accumulation. Consult local applicable standards for guidance. Additional references include American Petroleum Institute 2003 (Protection Against Ignitions Arising out of Static, Lightning and Stray Currents) or National Fire Protection Agency 77 (Recommended Practice on Static Electricity) or CENELEC CLC/TR 50404 (Electrostatics - Code of practice for the avoidance of hazards due to static electricity).

Static Accumulator: This material is a static accumulator.

STORAGE

The type of container used to store the material may affect static accumulation and dissipation. Do not store in open or unlabelled containers. Keep away from incompatible materials.

Material is defined under the National Standard [NOHSC:1015] Storage and Handling of Workplace Dangerous Goods.

SECTION 8 EXPOSURE CONTROLS / PERSONAL PROTECTION

EXPOSURE LIMIT VALUES

Exposure limits/standards (Note: Exposure limits are not additive)

Substance Name	Form	Limit/Standard		Note	Source
2,6-DI-TERT-BUTYL-P-CRESOL		TWA	10 mg/m ³		Australia OELs
2,6-DI-TERT-BUTYL-P-CRESOL	Inhalable fraction and vapour	TWA	2 mg/m ³		ACGIH

Exposure limits/standards for materials that can be formed when handling this product:

NOTE: Limits/standards shown for guidance only. Follow applicable regulations.

Biological limits

No biological limits allocated.

ENGINEERING CONTROLS

The level of protection and types of controls necessary will vary depending upon potential exposure conditions. Control measures to consider:

No special requirements under ordinary conditions of use and with adequate ventilation.

PERSONAL PROTECTION

Personal protective equipment selections vary based on potential exposure conditions such as applications, handling practices, concentration and ventilation. Information on the selection of protective equipment for use with this material, as provided below, is based upon intended, normal usage.

Respiratory Protection: If engineering controls do not maintain airborne contaminant concentrations at a level which is adequate to protect worker health, an approved respirator may be appropriate. Respirator selection, use, and maintenance must be in accordance with regulatory requirements, if applicable. Types of respirators to be considered for this material include:

Particulate

No special requirements under ordinary conditions of use and with adequate ventilation.

For high airborne concentrations, use an approved supplied-air respirator, operated in positive pressure mode. Supplied air respirators with an escape bottle may be appropriate when oxygen levels are inadequate, gas/vapour warning properties are poor, or if air purifying filter capacity/rating may be exceeded.

Hand Protection: Any specific glove information provided is based on published literature and glove manufacturer data. Glove suitability and breakthrough time will differ depending on the specific use conditions. Contact the glove manufacturer for specific advice on glove selection and breakthrough times for your use conditions. Inspect and replace worn or damaged gloves. The types of gloves to be considered for this material include:

Nitrile, Viton

No protection is ordinarily required under normal conditions of use.

Product Name: Mobil Vactra Oil No. 2

Revision Date: 30 Aug 2018

Page 5 of 8



Eye Protection: If contact is likely, safety glasses with side shields are recommended.

Skin and Body Protection: Any specific clothing information provided is based on published literature or manufacturer data. The types of clothing to be considered for this material include:

No skin protection is ordinarily required under normal conditions of use. In accordance with good industrial hygiene practices, precautions should be taken to avoid skin contact.

Specific Hygiene Measures: Always observe good personal hygiene measures, such as washing after handling the material and before eating, drinking, and/or smoking. Routinely wash work clothing and protective equipment to remove contaminants. Discard contaminated clothing and footwear that cannot be cleaned. Practise good housekeeping.

ENVIRONMENTAL CONTROLS

Comply with applicable environmental regulations limiting discharge to air, water and soil. Protect the environment by applying appropriate control measures to prevent or limit emissions.

SECTION 9 PHYSICAL AND CHEMICAL PROPERTIES

Note: Physical and chemical properties are provided for safety, health and environmental considerations only and may not fully represent product specifications. Contact the Supplier for additional information.

GENERAL INFORMATION

Physical State: Liquid
Colour: Amber
Odour: Characteristic
Odour Threshold: N/D

IMPORTANT HEALTH, SAFETY, AND ENVIRONMENTAL INFORMATION

Relative Density (at 15 °C):	0.883
Flammability (Solid, Gas):	N/A
Flash Point [Method]:	>205°C (401°F) [ASTM D-92]
Flammable Limits (Approximate volume % in air):	LEL: 0.9 UEL: 7.0
Autoignition Temperature:	N/D
Boiling Point / Range:	> 316°C (600°F)
Decomposition Temperature:	N/D
Vapour Density (Air = 1):	> 2 at 101 kPa
Vapour Pressure:	< 0.013 kPa (0.1 mm Hg) at 20 °C
Evaporation Rate (n-butyl acetate = 1):	N/D
pH:	N/A
Log Pow (n-Octanol/Water Partition Coefficient):	> 3.5
Solubility in Water:	Negligible
Viscosity:	68 cSt (68 mm ² /sec) at 40 °C 8.6 cSt (8.6 mm ² /sec) at 100°C
Oxidizing Properties:	See Hazards Identification Section.

OTHER INFORMATION

Freezing Point:	N/D
Melting Point:	N/A
Pour Point:	-6°C (21°F)
DMSO Extract (mineral oil only), IP-346:	< 3 %wt

SECTION 10 STABILITY AND REACTIVITY

STABILITY: Material is stable under normal conditions.

CONDITIONS TO AVOID: Excessive heat. High energy sources of ignition.

INCOMPATIBLE MATERIALS: Strong oxidisers

HAZARDOUS DECOMPOSITION PRODUCTS: Material does not decompose at ambient temperatures.

POSSIBILITY OF HAZARDOUS REACTIONS: Hazardous polymerization will not occur.

Product Name: Mobil Vactra Oil No. 2

Revision Date: 30 Aug 2018

Page 6 of 8



SECTION 11	TOXICOLOGICAL INFORMATION
-------------------	----------------------------------

INFORMATION ON TOXICOLOGICAL EFFECTS

Hazard Class	Conclusion / Remarks
Inhalation	
Acute Toxicity: No end point data for material	Minimally Toxic. Based on assessment of the components
Irritation: No end point data for material	Negligible hazard at ambient/normal handling temperatures
Ingestion	
Acute Toxicity: No end point data for material	Minimally Toxic. Based on assessment of the components.
Skin	
Acute Toxicity: No end point data for material	Minimally Toxic. Based on assessment of the components
Skin Corrosion/Irritation: No end point data for material	Negligible irritation to skin at ambient temperatures. Based on assessment of the components
Eye	
Serious Eye Damage/Irritation: No end point data for material	May cause mild, short-lasting discomfort to eyes. Based on assessment of the components.
Sensitization	
Respiratory Sensitization: No end point data for material.	Not expected to be a respiratory sensitizer.
Skin Sensitization: No end point data for material.	Not expected to be a skin sensitizer. Based on assessment of the components.
Aspiration: Data available.	Not expected to be an aspiration hazard. Based on physicochemical properties of the material.
Germ Cell Mutagenicity: No end point data for material.	Not expected to be a germ cell mutagen. Based on assessment of the components.
Carcinogenicity: No end point data for material.	Not expected to cause cancer. Based on assessment of the components.
Reproductive Toxicity: No end point data for material.	Not expected to be a reproductive toxicant. Based on assessment of the components.
Lactation: No end point data for material.	Not expected to cause harm to breast-fed children.
Specific Target Organ Toxicity (STOT)	
Single Exposure: No end point data for material.	Not expected to cause organ damage from a single exposure.
Repeated Exposure: No end point data for material.	Not expected to cause organ damage from prolonged or repeated exposure. Based on assessment of the components.

OTHER INFORMATION**For the product itself:**

Component concentrations in this formulation would not be expected to cause skin sensitization, based on tests of the components, this formulation, or similar formulations.

Contains:

Base oil severely refined: Not carcinogenic in animal studies. Representative material passes IP-346, Modified Ames test, and/or other screening tests. Dermal and inhalation studies showed minimal effects; lung non-specific infiltration of immune cells, oil deposition and minimal granuloma formation. Not sensitizing in test animals.

IARC Classification:

The following ingredients are cited on the lists below: None.

--REGULATORY LISTS SEARCHED--

1 = IARC 1 2 = IARC 2A 3 = IARC 2B

Product Name: Mobil Vactra Oil No. 2

Revision Date: 30 Aug 2018

Page 7 of 8

**SECTION 12 ECOLOGICAL INFORMATION**

The information given is based on data for the material, components of the material, or for similar materials, through the application of bridging principals.

ECOTOXICITY

Material -- Not expected to be harmful to aquatic organisms.

MOBILITY

Base oil component -- Low solubility and floats and is expected to migrate from water to the land.
Expected to partition to sediment and wastewater solids.

PERSISTENCE AND DEGRADABILITY**Biodegradation:**

Base oil component -- Expected to be inherently biodegradable

BIOACCUMULATION POTENTIAL

Base oil component -- Has the potential to bioaccumulate, however metabolism or physical properties may reduce the bioconcentration or limit bioavailability.

SECTION 13 DISPOSAL CONSIDERATIONS

Disposal recommendations based on material as supplied. Disposal must be in accordance with current applicable laws and regulations, and material characteristics at time of disposal.

DISPOSAL RECOMMENDATIONS

Product is suitable for burning in an enclosed controlled burner for fuel value or disposal by supervised incineration at very high temperatures to prevent formation of undesirable combustion products. Protect the environment. Dispose of used oil at designated sites. Minimize skin contact. Do not mix used oils with solvents, brake fluids or coolants.

Empty Container Warning Empty Container Warning (where applicable): Empty containers may contain residue and can be dangerous. Do not attempt to refill or clean containers without proper instructions. Empty drums should be completely drained and safely stored until appropriately reconditioned or disposed. Empty containers should be taken for recycling, recovery, or disposal through suitably qualified or licensed contractor and in accordance with governmental regulations. DO NOT PRESSURISE, CUT, WELD, BRAZE, SOLDER, DRILL, GRIND, OR EXPOSE SUCH CONTAINERS TO HEAT, FLAME, SPARKS, STATIC ELECTRICITY, OR OTHER SOURCES OF IGNITION. THEY MAY EXPLODE AND CAUSE INJURY OR DEATH.

SECTION 14 TRANSPORT INFORMATION

LAND (ADG): Not Regulated for Land Transport

SEA (IMDG): Not Regulated for Sea Transport according to IMDG-Code
Marine Pollutant: No

AIR (IATA): Not Regulated for Air Transport

SECTION 15 REGULATORY INFORMATION

This material is not considered hazardous according to Australia Model Work Health and Safety Regulations.

Product is not regulated according to Australian Dangerous Goods Code.

No Poison Schedule number allocated by the Standard for the Uniform Scheduling of Medicines and Poisons (SUSMP) established under the Therapeutic Goods Act.

AS1940 COMBUSTIBLE CLASS: C2

REGULATORY STATUS AND APPLICABLE LAWS AND REGULATIONS

Listed or exempt from listing/notification on the following chemical inventories (May contain substance(s) subject to notification to the EPA Active TSCA inventory prior to import to USA): AICS, DSL, ENCS, IECSC, KECI, PICCS, TCSI, TSCA

Product Name: Mobil Vactra Oil No. 2

Revision Date: 30 Aug 2018

Page 8 of 8

**SECTION 16****OTHER INFORMATION****KEY TO ABBREVIATIONS AND ACRONYMS:**

N/D = Not determined, N/A = Not applicable, STEL = Short-Term Exposure Limit, TWA = Time-Weighted Average

KEY TO THE H-CODES CONTAINED IN SECTION 3 OF THIS DOCUMENT (for information only):

H227: Combustible liquid; Flammable Liquid, Cat 4

H302: Harmful if swallowed; Acute Tox Oral, Cat 4

H317: May cause allergic skin reaction; Skin Sensitization, Cat 1

H318: Causes serious eye damage; Serious Eye Damage/Irr, Cat 1

H400: Very toxic to aquatic life; Acute Env Tox, Cat 1

H401: Toxic to aquatic life; Acute Env Tox, Cat 2

H410: Very toxic to aquatic life with long lasting effects; Chronic Env Tox, Cat 1

H411: Toxic to aquatic life with long lasting effects; Chronic Env Tox, Cat 2

THIS SAFETY DATA SHEET CONTAINS THE FOLLOWING REVISIONS:

Southern Cross Lubes (Victoria and Tasmania): Section 01: Supplier Mailing Address information was deleted.

Southern Cross Lubes (Victoria and Tasmania, New South Wales and Australian Capital Territory): Section 01:

Supplier Mailing Address information was added.

Section 11 Acute Toxicity data - Header information was deleted.

Section 11 Substance Name - Header information was deleted.

Section 11 Substance Toxicity table - Header information was deleted.

Section 11 Substance Toxicology table information was deleted.

Section 12: information was modified.

The information and recommendations contained herein are, to the best of ExxonMobil's knowledge and belief, accurate and reliable as of the date issued. You can contact ExxonMobil to ensure that this document is the most current available from ExxonMobil. The information and recommendations are offered for the user's consideration and examination. It is the user's responsibility to satisfy itself that the product is suitable for the intended use. If buyer repackages this product, it is the user's responsibility to ensure proper health, safety and other necessary information is included with and/or on the container. Appropriate warnings and safe-handling procedures should be provided to handlers and users. Alteration of this document is strictly prohibited. Except to the extent required by law, republication, or retransmission of this document, in whole or in part, is not permitted. The term, "ExxonMobil" is used for convenience, and may include any one or more of ExxonMobil Chemical Company, Exxon Mobil Corporation, or any affiliates in which they directly or indirectly hold any interest.

DGN: 7053124DAU (1014681)

Prepared by: Exxon Mobil Corporation
EMBSI, Clinton NJ USA

Contact Point: See Section 1 for Local Contact number

End of (M)SDS

Product Name: Mobil Polyrex EP 2
 Revision Date: 25 Jul 2018
 Page 1 of 7



SAFETY DATA SHEET

SECTION 1 PRODUCT AND COMPANY IDENTIFICATION

PRODUCT

Product Name: MOBIL POLYREX EP 2
Product Description: Base Oil and Additives
Product Code: 2015A020G020, 641696-00, 97Y279
Intended Use: Grease

COMPANY IDENTIFICATION

Supplier: EXXON MOBIL CORPORATION
 22777 Springwoods Village Parkway
 Spring, TX 77389, USA

24 Hour Health Emergency 609-737-441
Transportation Emergency Phone 800-424-9300 or 703-527-3887 CHEMTREC
Product Technical Information 800-662-4525
MSDS Internet Address www.exxon.com, www.mobil.com

SECTION 2 HAZARDS IDENTIFICATION

This material is not hazardous according to regulatory guidelines (see (M)SDS Section 15).

Other hazard information:

HAZARD NOT OTHERWISE CLASSIFIED (HNOC): None as defined under 29 CFR 1910.1200.

PHYSICAL / CHEMICAL HAZARDS

No significant hazards.

HEALTH HAZARDS

High-pressure injection under skin may cause serious damage. Excessive exposure may result in eye, skin, or respiratory irritation.

ENVIRONMENTAL HAZARDS

No significant hazards.

NFPA Hazard ID: Health: 0 Flammability: 1 Reactivity: 0

HMIS Hazard ID: Health: 0 Flammability: 1 Reactivity: 0

NOTE: This material should not be used for any other purpose than the intended use in Section 1 without expert advice. Health studies have shown that chemical exposure may cause potential human health risks which may vary from person to person.

SECTION 3 COMPOSITION / INFORMATION ON INGREDIENTS

This material is defined as a mixture.

Reportable Hazardous Substance(s) or Complex Substance(s)

Name	CAS#	Concentration	GHS Hazard Codes
CARBONIC ACID, CALCIUM SALT (1:1)	471-34-1	5 - < 10%	None

* All concentrations are percent by weight unless ingredient is a gas. Gas concentrations are in percent by volume.

As per paragraph (i) of 29 CFR 1910.1200, formulation is considered a trade secret and specific chemical identity and exact percentage (concentration) of composition may have been withheld. Specific chemical identity and exact percentage composition will be provided to health professionals, employees, or designated representatives in accordance with applicable provisions of paragraph (i).

Product Name: Mobil Polyrex EP 2

Revision Date: 25 Jul 2018

Page 2 of 7

**SECTION 4 FIRST AID MEASURES****INHALATION**

Under normal conditions of intended use, this material is not expected to be an inhalation hazard.

SKIN CONTACT

Wash contact areas with soap and water. If product is injected into or under the skin, or into any part of the body, regardless of the appearance of the wound or its size, the individual should be evaluated immediately by a physician as a surgical emergency. Even though initial symptoms from high pressure injection may be minimal or absent, early surgical treatment within the first few hours may significantly reduce the ultimate extent of injury.

EYE CONTACT

Flush thoroughly with water. If irritation occurs, get medical assistance.

INGESTION

First aid is normally not required. Seek medical attention if discomfort occurs.

SECTION 5 FIRE FIGHTING MEASURES**EXTINGUISHING MEDIA**

Appropriate Extinguishing Media: Use water fog, foam, dry chemical or carbon dioxide (CO₂) to extinguish flames.

Inappropriate Extinguishing Media: Straight streams of water

FIRE FIGHTING

Fire Fighting Instructions: Evacuate area. Prevent run-off from fire control or dilution from entering streams, sewers or drinking water supply. Fire-fighters should use standard protective equipment and in enclosed spaces, self-contained breathing apparatus (SCBA). Use water spray to cool fire exposed surfaces and to protect personnel.

Hazardous Combustion Products: Aldehydes, Incomplete combustion products, Oxides of carbon, Smoke, Fume, Sulphur oxides

FLAMMABILITY PROPERTIES

Flash Point [Method]: >168°C (334°F) [EST. FOR OIL, ASTM D-92 (COC)]

Flammable Limits (Approximate volume % in air): LEL: N/D UEL: N/D

Autoignition Temperature: N/A

SECTION 6 ACCIDENTAL RELEASE MEASURES**NOTIFICATION PROCEDURES**

In the event of a spill or accidental release, notify relevant authorities in accordance with all applicable regulations. US regulations require reporting releases of this material to the environment which exceed the applicable reportable quantity or oil spills which could reach any waterway including intermittent dry creeks. The National Response Center can be reached at (800)424-8802.

PROTECTIVE MEASURES

Avoid contact with spilled material. See Section 5 for firefighting information. See the Hazard Identification Section for Significant Hazards. See Section 4 for First Aid Advice. See Section 8 for advice on the minimum requirements for personal protective equipment. Additional protective measures may be necessary, depending on the specific circumstances and/or the expert judgment of the emergency responders.

For emergency responders: Respiratory protection: respiratory protection will be necessary only in special cases, e.g., formation of mists. Half-face or full-face respirator with filter(s) for dust/organic vapor or Self Contained Breathing Apparatus (SCBA) can be used depending on the size of spill and potential level of exposure. If the exposure cannot be completely characterized or an oxygen deficient atmosphere is possible or anticipated, SCBA is recommended. Work gloves that are resistant to hydrocarbons are recommended. Gloves made of polyvinyl acetate (PVA) are not water-resistant and are not suitable for emergency use. Chemical goggles are recommended if splashes or contact with eyes is possible. Small spills: normal antistatic work clothes are usually adequate. Large spills: full body suit of chemical resistant, antistatic material is recommended.

SPILL MANAGEMENT

Land Spill: Stop leak if you can do so without risk. Recover by pumping or with suitable absorbent.

Product Name: Mobil Polyrex EP 2

Revision Date: 25 Jul 2018

Page 3 of 7



Water Spill: Stop leak if you can do so without risk. Confine the spill immediately with booms. Warn other shipping. Remove from the surface by skimming or with suitable absorbents. Seek the advice of a specialist before using dispersants.

Water spill and land spill recommendations are based on the most likely spill scenario for this material; however, geographic conditions, wind, temperature, (and in the case of a water spill) wave and current direction and speed may greatly influence the appropriate action to be taken. For this reason, local experts should be consulted. Note: Local regulations may prescribe or limit action to be taken.

ENVIRONMENTAL PRECAUTIONS

Prevent entry into waterways, sewers, basements, or confined areas.

SECTION 7 HANDLING AND STORAGE

HANDLING

Prevent small spills and leakage to avoid slip hazard

Static Accumulator: This material is a static accumulator.

STORAGE

The type of container used to store the material may affect static accumulation and dissipation. Do not store in open or unlabelled containers. Keep away from incompatible materials.

Material is defined under the National Standard [NOHSC:1015] Storage and Handling of Workplace Dangerous Goods.

SECTION 8 EXPOSURE CONTROLS / PERSONAL PROTECTION

EXPOSURE LIMIT VALUES

Exposure limits/standards (Note: Exposure limits are not additive)

Substance Name	Form	Limit/Standard			Note	Source
CARBONIC ACID, CALCIUM SALT (1:1)	Respirable fraction	TWA	5 mg/m ³			OSHA Z1
CARBONIC ACID, CALCIUM SALT (1:1)	Total dust	TWA	15 mg/m ³			OSHA Z1

Exposure limits/standards for materials that can be formed when handling this product:

NOTE: Limits/standards shown for guidance only. Follow applicable regulations.

Biological limits

No biological limits allocated.

ENGINEERING CONTROLS

The level of protection and types of controls necessary will vary depending upon potential exposure conditions.

Control measures to consider:

No special requirements under ordinary conditions of use and with adequate ventilation.

PERSONAL PROTECTION

Personal protective equipment selections vary based on potential exposure conditions such as applications, handling practices, concentration and ventilation. Information on the selection of protective equipment for use with this material, as provided below, is based upon intended, normal usage.

Respiratory Protection: If engineering controls do not maintain airborne contaminant concentrations at a level which is adequate to protect worker health, an approved respirator may be appropriate. Respirator selection, use, and maintenance must be in accordance with regulatory requirements, if applicable. Types of respirators to be considered for this material include:

No special requirements under ordinary conditions of use and with adequate ventilation.

For high airborne concentrations, use an approved supplied-air respirator, operated in positive pressure mode. Supplied air respirators with an escape bottle may be appropriate when oxygen levels are inadequate, gas/vapour warning properties are poor, or if air purifying filter capacity/rating may be exceeded.

Product Name: Mobil Polyrex EP 2

Revision Date: 25 Jul 2018

Page 4 of 7



Hand Protection: Any specific glove information provided is based on published literature and glove manufacturer data. Glove suitability and breakthrough time will differ depending on the specific use conditions. Contact the glove manufacturer for specific advice on glove selection and breakthrough times for your use conditions. Inspect and replace worn or damaged gloves. The types of gloves to be considered for this material include:

No protection is ordinarily required under normal conditions of use.

Eye Protection: If contact is likely, safety glasses with side shields are recommended.

Skin and Body Protection: Any specific clothing information provided is based on published literature or manufacturer data. The types of clothing to be considered for this material include:

No skin protection is ordinarily required under normal conditions of use. In accordance with good industrial hygiene practices, precautions should be taken to avoid skin contact.

Specific Hygiene Measures: Always observe good personal hygiene measures, such as washing after handling the material and before eating, drinking, and/or smoking. Routinely wash work clothing and protective equipment to remove contaminants. Discard contaminated clothing and footwear that cannot be cleaned. Practise good housekeeping.

ENVIRONMENTAL CONTROLS

Comply with applicable environmental regulations limiting discharge to air, water and soil. Protect the environment by applying appropriate control measures to prevent or limit emissions.

SECTION 9 PHYSICAL AND CHEMICAL PROPERTIES

Note: Physical and chemical properties are provided for safety, health and environmental considerations only and may not fully represent product specifications. Contact the Supplier for additional information.

GENERAL INFORMATION

Physical State: Solid
Form: Semi-fluid
Colour: Blue-Green
Odour: Characteristic
Odour Threshold: N/D

IMPORTANT HEALTH, SAFETY, AND ENVIRONMENTAL INFORMATION

Relative Density (at 15 °C):	0.9
Flammability (Solid, Gas):	N/A
Flash Point [Method]:	>168°C (334°F) [Est. for oil, ASTM D-92 (COC)]
Flammable Limits (Approximate volume % in air):	LEL: N/D UEL: N/D
Autoignition Temperature:	N/D
Boiling Point / Range:	> 330°C (626°F)
Decomposition Temperature:	N/D
Vapour Density (Air = 1):	N/D
Vapour Pressure:	< 0.013 kPa (0.1 mm Hg) at 20 °C
Evaporation Rate (n-butyl acetate = 1):	N/D
pH:	N/A
Log Pow (n-Octanol/Water Partition Coefficient):	> 3.5
Solubility in Water:	Negligible
Viscosity:	>211 cSt (211 mm ² /sec) at 40 °C >16.6 cSt (16.6 mm ² /sec) at 100°C
Oxidizing Properties:	See Hazards Identification Section.

OTHER INFORMATION

Freezing Point: N/D
Melting Point: 265°C (509°F)
DMSO Extract (mineral oil only), IP-346: < 3 %wt

Note: Most physical properties above are for the oil component in the material

SECTION 10 STABILITY AND REACTIVITY

REACTIVITY: See sub-sections below

STABILITY: Material is stable under normal conditions.

Product Name: Mobil Polyrex EP 2

Revision Date: 25 Jul 2018

Page 5 of 7

**CONDITIONS TO AVOID:** Excessive heat. High energy sources of ignition.**INCOMPATIBLE MATERIALS:** Strong oxidizers**HAZARDOUS DECOMPOSITION PRODUCTS:** Material does not decompose at ambient temperatures.**POSSIBILITY OF HAZARDOUS REACTIONS:** Hazardous polymerization will not occur.

SECTION 11	TOXICOLOGICAL INFORMATION
-------------------	----------------------------------

INFORMATION ON TOXICOLOGICAL EFFECTS

Hazard Class	Conclusion / Remarks
Inhalation	
Acute Toxicity: No end point data for material	Minimally Toxic. Based on assessment of the components
Irritation: No end point data for material	Negligible hazard at ambient/normal handling temperatures
Ingestion	
Acute Toxicity: No end point data for material	Minimally Toxic. Based on assessment of the components.
Skin	
Acute Toxicity: No end point data for material	Minimally Toxic. Based on assessment of the components
Skin Corrosion/Irritation: No end point data for material	Negligible irritation to skin at ambient temperatures. Based on assessment of the components
Eye	
Serious Eye Damage/Irritation: No end point data for material	May cause mild, short-lasting discomfort to eyes. Based on assessment of the components.
Sensitization	
Respiratory Sensitization: No end point data for material.	Not expected to be a respiratory sensitizer.
Skin Sensitization: No end point data for material.	Not expected to be a skin sensitizer. Based on assessment of the components.
Aspiration: Data available.	Not expected to be an aspiration hazard. Based on physicochemical properties of the material.
Germ Cell Mutagenicity: No end point data for material.	Not expected to be a germ cell mutagen. Based on assessment of the components.
Carcinogenicity: No end point data for material.	Not expected to cause cancer. Based on assessment of the components.
Reproductive Toxicity: No end point data for material.	Not expected to be a reproductive toxicant. Based on assessment of the components.
Lactation: No end point data for material.	Not expected to cause harm to breast-fed children.
Specific Target Organ Toxicity (STOT)	
Single Exposure: No end point data for material.	Not expected to cause organ damage from a single exposure.
Repeated Exposure: No end point data for material.	Not expected to cause organ damage from prolonged or repeated exposure. Based on assessment of the components.

OTHER INFORMATION**For the product itself:**

Component concentrations in this formulation would not be expected to cause skin sensitization, based on tests of the components, this formulation, or similar formulations.

Contains:

Base oil severely refined: Not carcinogenic in animal studies. Representative material passes IP-346, Modified Ames test, and/or other screening tests. Dermal and inhalation studies showed minimal effects; lung non-specific infiltration of immune cells, oil deposition and minimal granuloma formation. Not sensitizing in test animals.

IARC Classification:

The following ingredients are cited on the lists below: None.

--REGULATORY LISTS SEARCHED--

1 = NTP CARC

3 = IARC 1

5 = IARC 2B

2 = NTP SUS

4 = IARC 2A

6 = OSHA CARC

Product Name: Mobil Polyrex EP 2

Revision Date: 25 Jul 2018

Page 6 of 7

**SECTION 12 ECOLOGICAL INFORMATION**

The information given is based on data for the material, components of the material, or for similar materials, through the application of bridging principals.

ECOTOXICITY

Material -- Not expected to be harmful to aquatic organisms.

MOBILITY

Base oil component -- Low solubility and floats and is expected to migrate from water to the land.
Expected to partition to sediment and wastewater solids.

PERSISTENCE AND DEGRADABILITY**Biodegradation:**

Base oil component -- Expected to be inherently biodegradable

BIOACCUMULATION POTENTIAL

Base oil component -- Has the potential to bioaccumulate, however metabolism or physical properties may reduce the bioconcentration or limit bioavailability.

SECTION 13 DISPOSAL CONSIDERATIONS

Disposal recommendations based on material as supplied. Disposal must be in accordance with current applicable laws and regulations, and material characteristics at time of disposal.

DISPOSAL RECOMMENDATIONS

Product is suitable for burning in an enclosed controlled burner for fuel value or disposal by supervised incineration at very high temperatures to prevent formation of undesirable combustion products.

REGULATORY DISPOSAL INFORMATION

RCRA Information: The unused product, in our opinion, is not specifically listed by the EPA as a hazardous waste (40 CFR, Part 261D), nor is it formulated to contain materials which are listed as hazardous wastes. It does not exhibit the hazardous characteristics of ignitability, corrosivity or reactivity and is not formulated with contaminants as determined by the Toxicity Characteristic Leaching Procedure (TCLP). However, used product may be regulated.

Empty Container Warning Empty Container Warning (where applicable): Empty containers may contain residue and can be dangerous. Do not attempt to refill or clean containers without proper instructions. Empty drums should be completely drained and safely stored until appropriately reconditioned or disposed. Empty containers should be taken for recycling, recovery, or disposal through suitably qualified or licensed contractor and in accordance with governmental regulations. DO NOT PRESSURISE, CUT, WELD, BRAZE, SOLDER, DRILL, GRIND, OR EXPOSE SUCH CONTAINERS TO HEAT, FLAME, SPARKS, STATIC ELECTRICITY, OR OTHER SOURCES OF IGNITION. THEY MAY EXPLODE AND CAUSE INJURY OR DEATH.

SECTION 14 TRANSPORT INFORMATION

LAND (DOT): Not Regulated for Land Transport

LAND (ADG): Not Regulated for Land Transport

SEA (IMDG): Not Regulated for Sea Transport according to IMDG-Code
Marine Pollutant: No

AIR (IATA): Not Regulated for Air Transport

SECTION 15 REGULATORY INFORMATION

OSHA HAZARD COMMUNICATION STANDARD: This material is not considered hazardous in accordance with OSHA HazCom 2012, 29 CFR 1910.1200.

Listed or exempt from listing/notification on the following chemical inventories: IECSC, TCSI, TSCA

SARA 302: No chemicals in this material are subject to the reporting requirements of SARA Title III, Section 302

SARA (311/312) REPORTABLE GHS HAZARD CLASSES: None.

Product Name: Mobil Polyrex EP 2

Revision Date: 25 Jul 2018

Page 7 of 7

ExxonMobil

SARA (313) TOXIC RELEASE INVENTORY: This material contains no chemicals subject to the supplier notification requirements of the SARA 313 Toxic Release Program.

The following ingredients are cited on the lists below:

Chemical Name	CAS Number	List Citations
CARBONIC ACID, CALCIUM SALT (1:1)	471-34-1	4, 16, 17, 18
DIPHENYLAMINE	122-39-4	18
HYDROTREATED HEAVY NAPHTHENIC DISTILLATE	64742-52-5	13, 17, 18
NAPHTHALENE	91-20-3	10

--REGULATORY LISTS SEARCHED--

1 = ACGIH ALL	6 = TSCA 5a2	11 = CA P65 REPRO	16 = MN RTK
2 = ACGIH A1	7 = TSCA 5e	12 = CA RTK	17 = NJ RTK
3 = ACGIH A2	8 = TSCA 6	13 = IL RTK	18 = PA RTK
4 = OSHA Z	9 = TSCA 12b	14 = LA RTK	19 = RI RTK
5 = TSCA 4	10 = CA P65 CARC	15 = MI 293	

Code key: CARC=Carcinogen; REPRO=Reproductive

SECTION 16 OTHER INFORMATION



WARNING: Cancer - www.P65Warnings.ca.gov.

This warning is given to comply with California Health and Safety Code 25249.6 and does not constitute an admission or a waiver of rights.

N/D = Not determined, N/A = Not applicable

THIS SAFETY DATA SHEET CONTAINS THE FOLLOWING REVISIONS:

Section 12: information was modified.

Section 15: SARA (311/312) REPORTABLE GHS HAZARD CLASSES information was added.

Section 15: SARA (311/312) REPORTABLE HAZARD CATEGORIES information was deleted.

Section 16: Standard phrases for California Proposition 65 information was modified.

The information and recommendations contained herein are, to the best of ExxonMobil's knowledge and belief, accurate and reliable as of the date issued. You can contact ExxonMobil to ensure that this document is the most current available from ExxonMobil. The information and recommendations are offered for the user's consideration and examination. It is the user's responsibility to satisfy itself that the product is suitable for the intended use. If buyer repackages this product, it is the user's responsibility to ensure proper health, safety and other necessary information is included with and/or on the container. Appropriate warnings and safe-handling procedures should be provided to handlers and users. Alteration of this document is strictly prohibited. Except to the extent required by law, republication, or retransmission of this document, in whole or in part, is not permitted. The term, "ExxonMobil" is used for convenience, and may include any one or more of ExxonMobil Chemical Company, Exxon Mobil Corporation, or any affiliates in which they directly or indirectly hold any interest.

Internal Use Only

MHC: 0B, 0B, 0, 0, 0, 0

PPEC: A

DGN: 7053124DAU (1014681)

End of (M)SDS