



## **SG 80M**

**SEAT AND GUIDE MACHINE**

MACHINE SERIAL NUMBER

---



**OPERATIONS AND MAINTENANCE  
MANUAL**

**MANUFACTURED BY:**

**ROTTLER MANUFACTURING COMPANY**  
8029 South 200th Street  
Kent Washington 98032  
USA

Phone: (253) 872-7050  
Fax: (253) 395-0230  
Website: <http://www.rottlermfg.com>



## MANUAL CONTENTS

<b>Section 1</b>	<b>Introduction</b>
<b>Section 2</b>	<b>Installation</b>
<b>Section 3</b>	<b>Safety</b>
<b>Section 4</b>	<b>Control Definition</b>
<b>Section 5</b>	<b>Operating Instructions</b>
<b>Section 6</b>	<b>Maintenance</b>
<b>Section 7</b>	<b>Troubleshooting</b>
<b>Section 8</b>	<b>Machine Parts</b>
<b>Section 9</b>	<b>Options (located in a separate manual)</b>
<b>Section 10</b>	<b>MSDS</b>

Table of Contents for each section are at the beginning of each section.

## ORDERING PROCEDURE

Contact your regional Rottler sales rep for assistance in ordering optional equipment, replacement parts, or tooling.

If you are unable to contact your regional Rottler sales rep, call the factory at 253-872-7050 and ask to speak to the parts sales specialist.

Have the following information handy to expedite the ordering process:

1. Your name, business name, and contact number
2. Customer number
3. If you don't have a customer number, your billing address
4. Shipping address if different from billing address
5. Machine model and serial number
6. Part number and description of what you want to order
7. Preferred method of shipment

You may also contact us via e-mail with the above information. Send e-mail requests to: [parts@rottermfg.com](mailto:parts@rottermfg.com)

In some cases you may be requested to send a photo of the part you are ordering if it is a replacement part, or doesn't appear in the database.

If you are unsure which part you need to order, contact our service department and ask to speak to one of our service consultants. They will assist you in determining which part you require.

**THERE IS A MINIMUM ORDER OF \$25.00**





# INTRODUCTION

**READ THE SAFETY CHAPTER BEFORE INSTALLING MACHINE. THOROUGHLY UNDERSTAND ALL SAFETY ISSUES BEFORE OPERATING MACHINE.**

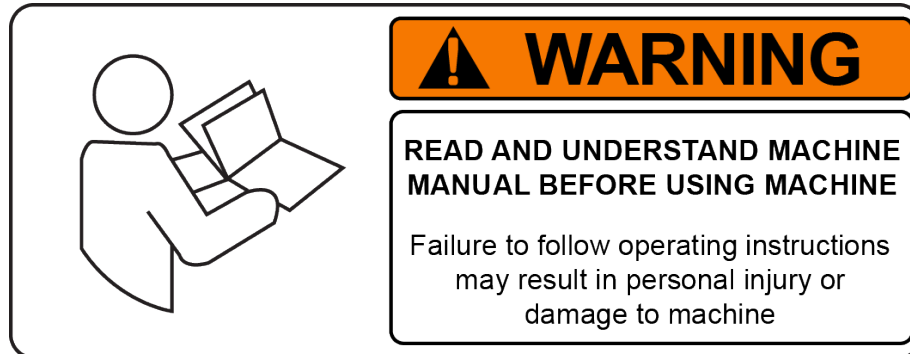

## ATTENTION OWNER/BUSINESS MANAGER

**To validate the warranty on your new Rottler machine, please be sure to sign and complete the “Installation Report” located in the Installation Chapter of this manual.**

We suggest that the new user of the SG80M read the CONTROL DEFINITIONS to get an idea how the machine operates.

The Operating Instructions chapter should be read in order to familiarize the user with the actual button pushing sequences required to carry out a job. These chapters in the manual should be considered an introduction. As the operators of the SG80M series machines gain experience with using the different functions of the machine, complicated setups and programs will make more sense.

The rest of the manual contains information and part number reference on fixtures, cutting tools, and machine maintenance. The operator should read and become familiar with these areas as well.

**Description**

The model SG80M machine is a precision seat finish machine designed to maintain accuracy on every finished seat.

Can be equipped with tooling and accessories to handle most American, Import, and Diesel passenger car and truck cylinder heads.

Convenient controls, easy cylinder Head Clamping, air floated spindle base (Work Head) centering on the pilot shank and clamping, means considerable savings in floor to floor time, and operator involvement. Making this machine highly suited to the jobber shop where accuracy and dependability is required.

**Disclaimer**

The SG80M Manual (henceforth to be referred to as the "Manual") is proprietary to Rottler Manufacturing LLC. ("Rottler Manufacturing") and no ownership rights are hereby transferred. No part of the Manual shall be used, reproduced, translated, converted, adapted, stored in a retrieval system, communicated or transmitted by any means, for any commercial purpose, including without limitation, sale, resale, license, rental or lease, without the prior express written consent of Rottler Manufacturing.

Rottler Manufacturing does not make any representations, warranties or guarantees, express or implied, as to the accuracy or completeness of the Manual. Users must be aware that updates and amendments will be made from time to time to the Manual. It is the user's responsibility to determine whether there have been any such updates or amendments. Neither Rottler Manufacturing nor any of its directors, officers, employees or agents shall not be liable in any manner whatsoever to any person for any loss, damage, injury, liability, cost or expense of any nature, including without limitation incidental, special, direct or consequential damages arising out of or in connection with the use of the Manual.

**Limited Warranty**

Rottler Manufacturing Company Model SG80M parts and equipment is warranted as to materials and workmanship. This limited warranty remains in effect for one year from the date of delivery, provided the machine is owned and operated by the original purchaser and is operated and maintained as per the instructions in the manual.

Tools proven to be defective within the warranty period will be repaired or replaced at the factory's option.

The products are warranted upon delivery to conform to their published specifications and to be free from defects in material and workmanship under normal use for a period of one year from shipment. Should a product not be as warranted, Rottler sole obligation shall be, at its option, to repair, correct or replace the product or to refund the amounts paid for the Product upon its return to a location designated by Rottler. No warranty shall extend to rapid wear Products (including tooling) or to Products which have been subject to misuse (including any use contrary to Rottler instructions), neglect, accident (including during shipment), improper handling or installation, or subject to any modification, repair or service not certified by Rottler. Rottler shall not be liable for any consequential, direct or indirect damages or for any other injury or loss. Buyer waives any right, beyond the foregoing warranty, to make a claim against Rottler. No warranty is provided for any Products not paid in full.

Merchandise cannot be returned to Rottler without prior approval. Customer must contact the Order Department or representative to get approval and to be issued a Return Goods Authorization number (RGR#). Merchandise authorized for return must be returned prepaid. If merchandise is returned with shipping charges collect, the actual amount of these charges may be deducted from any credit which may be due the customer. The RGR # assigned by the Order Department should be written on the shipping label and must appear on a copy of the invoice(s) covering the original shipment. This invoice copy must be included in the box with the parts. Shipment must contain ONLY those items on the RGR as approved for return. Merchandise must be received within 10 days of the date of RGR or the RGR will be canceled. All returned merchandise may be subject to a 20% restocking fee on under \$1,000.00 amount or 10% on any items over \$1,000.00. Parts or tooling over 30 days old are considered as customer property and can only be returned with prior written approval from Rottler Corporation Management and/or Shipping Department.

***The issuance of a RGR DOES NOT guarantee credit*** - it is only authorization for the return of the goods. Credit for return merchandise is at the sole discretion of Rottler. Credit will be issued only after inspection of returned goods.

Tools proven to be defective within the warranty period will be repaired or replaced at the factory's option. We accept no responsibility for defects caused by external damage, wear, abuse, or misuse, nor do we accept any obligation to provide compensation for direct or indirect costs in connection with cases covered by the warranty.

This page intentionally left blank

# INSTALLATION

## Contents

<b>ROTTLER SG80M INSTALLATION REPORT .....</b>	<b>2-2</b>
<b>Installation Procedure.....</b>	<b>2-6</b>
<b>Location.....</b>	<b>2-6</b>
<b>Unpacking and Lifting.....</b>	<b>2-6</b>
<b>Positioning the Machine .....</b>	<b>2-6</b>
<b>Removing shipping brackets .....</b>	<b>2-7</b>
<b>Leveling the Machine .....</b>	<b>2-8</b>
<b>Air Supply.....</b>	<b>2-9</b>
<b>Air Adjustments .....</b>	<b>2-9</b>
<b>Float.....</b>	<b>2-9</b>
<b>Power Supply.....</b>	<b>2-10</b>
<b>Grounding.....</b>	<b>2-10</b>

## **ATTENTION OWNER/BUSINESS MANAGER**

**To validate the warranty on your new Rottler machine, please be sure to sign the installation report after the installation technician has installed the machine and verified the machine is operating correctly and given the operators operation and maintenance training.**

**Thank you for your cooperation and the opportunity to be of service to you.**

***ROTTLER MANUFACTURING***

Route to: John Fisher ———> Andy ———> Machine Packet File  
 SG80M Installation Report Rev 03242015

## ROTTLER SG80M INSTALLATION REPORT

### ROTTLER MANUFACTURING MUST HAVE THIS REPORT RETURNED TO PROPERLY QUALIFY WARRANTY ON EQUIPMENT

Customer: \_\_\_\_\_ Address: \_\_\_\_\_  
 City: \_\_\_\_\_ State: \_\_\_\_\_ Zip: \_\_\_\_\_ Phone: \_\_\_\_\_  
 Machine Model: \_\_\_\_\_ Serial Number: \_\_\_\_\_ Representative: \_\_\_\_\_

**MACHINE INSTALLATION:** Electrical information MUST be complete to validate this report.

Customer is responsible for providing electricity to machine in a manner that meets the local electrical code requirements.

- \_\_\_\_\_ Check machine level for equal support on feet.
- \_\_\_\_\_ This machine requires between 208 and 240 Volts AC, Single Phase, 50/60 Hz, isolated power supply.  
 Measure the incoming voltage between L1 and L2. Current requirements for this machine are 15 amps.  
 Measure the incoming AC voltage at least twice during installation.  
 1) \_\_\_\_\_ VAC    2) \_\_\_\_\_ VAC
- \_\_\_\_\_ Measure each leg of the incoming supply to ground. When using a one leg and neutral of a 380 VAC three phase supply L1 should measure 240 VAC and Neutral should measure almost 0 VAC.  
 L1 to ground \_\_\_\_\_ VAC    L2 to ground \_\_\_\_\_ VAC.

Make sure all electrical equipment has the proper overload protection. The SG80A should have a **fully isolated** power supply to prevent damage and uncontrolled movement of the machine. If the SG80A is on the same power lines that are running to other electrical equipment (grinders, welders, and other AC motors) electrical noise can be induced into the SG80A electrical system. Electrical noise can cause the controller to see false signals to move.

**CAUTION** Neutral and machine ground are not the same thing. You should measure an open circuit between Neutral and ground.

**CAUTION** **IF VOLTAGE IS OUTSIDE THE CORRECT RANGE AT ANY TIME THE MACHINE WILL NOT OPERATE PROPERLY AND MAY BE DAMAGED.**

- \_\_\_\_\_ **BEFORE** turning power on to the machine. Check all wires for security by using the correct screw driver and turning CW until movement stops. Stranded wire can “spread” slightly from vibration during transport.
- \_\_\_\_\_ Air of the proper pressure and capacity connected to the machine. Air supply must be free from oil and water. Oil or water will damage electrical and air components. Air pressure should never drop below 90 PSI at any time. Failure to provide adequate air supply may cause improper floating and clamping.
- \_\_\_\_\_ Remove all shipping brackets in accordance with the machine manual.
- \_\_\_\_\_ Clean any rust inhibitor from the machine surfaces. Slide the spindle base from side to side continually cleaning the machine base until all inhibitor is removed.

- \_\_\_\_\_ Have the operator read through the operation manual before training begins. This will help him be familiar with the button pushing sequences. Have the operator read through the manual again after training and some of the sequences will make more sense.
- \_\_\_\_\_ Calibrate angle sensor.

### MACHINE START-UP



When starting the machine for the first time, it may move out of control. Make sure all hands are clear of machine parts. Be ready to press the Emergency Stop button if needed.

- \_\_\_\_\_ Turn main power on from the main incoming breaker box.

### MACHINE MOVEMENTS

- \_\_\_\_\_ Make sure there is nothing obstructing the full vertical travel of the machine.
- \_\_\_\_\_ When the machine is on the clamp mode and the air pressure is with the requirements, tray to move workhead to verify that you have a solid clamp of Work head.
- \_\_\_\_\_ Place the level on the leveling post. The level assembly is referenced to the spindle via the level pin. It is therefore important to check alignment of the pin in reference to the spindle. Even though the level has been carefully calibrated at the factory, it is a good idea to recheck calibration before putting the machine into service. In the event that the level is dropped or handled roughly then the following recalibration methods should be implemented. If calibration is required refer to manual for Calibrating the Digital Level
- \_\_\_\_\_ Start the spindle and verify operation.

### INSTRUCTING THE OPERATOR

- \_\_\_\_\_ Using the operating manual as a guide explain the function of all buttons.
- \_\_\_\_\_ Cycle all machine movements and supervise the handling of same by operator.
- \_\_\_\_\_ Demonstrate the engaging of the fine feed system.
- \_\_\_\_\_ Point out safety features to customer and operator.
- Do not push any buttons without thinking of safety first.**



Do not assume the Digital level has been calibrated rotate 180 to verify alignment.

- \_\_\_\_\_ The following is a checklist to go through every time the machine is started to begin machining a seat.
- Work piece secure
  - RPM set
  - Tool holder adjusted to the correct setting base on the type of seat you will be machining
  - Tool holder locked in place
  - Floating of the Workhead and clamping
- \_\_\_\_\_ Proceed to have operator to machine a seat under you control.
- \_\_\_\_\_ **Parts ordering, refer to the operating manual for part numbers and description.**
- \_\_\_\_\_ Review Emergency stop procedure and with operator per operating manual.





This page intentionally left blank

## Installation Procedure

### Location

The productivity of the SG80M will depend a great deal on the proper initial installation. Pay particular attention to the means by which work pieces are lifted into and out of the machine as well as the material handling to and from other operations in your shop. The proper loading arrangements and work location for your SG80M is extremely important.

For shops where large production runs are anticipated, the work pieces should be loaded and unloaded directly from a conveyor. If this is not the case, we suggest you pay considerable attention to the crane so that it covers an adequate area to allow the operator to back up and remove work pieces without creating a cluttered, dangerous work area.

### Unpacking and Lifting

Use care when removing the crate materials from the machine. Be careful not to use force on any part of the machine.

Remove the shipping screws (4) from the skid; the shipping brackets will be painted red for easy identification. These screws are located at the four bottom corners of the Main Base.



**THIS MACHINE IS TOP-HEAVY.** Use care when lifting and moving Machine. Approximate shipping

Weight of Machine is 5000 lbs. (2273 kg).

### Positioning the Machine



Lift Machine using a fork lift. Move fork lift to front of Machine and separate forks so they are visually centered. Insert forks under front-center of Machine, using care not to damage Foot Pedals Valve or Air Lines. Tilt forks slightly upward so Machine will lean toward fork lift and lift Machine.

While Machine is on fork lift, install five (6) Leveling Screws and Jam Nuts in holes provided in bottom of Machine Base. Two (2) Screws installed in rear-corners and one (2) Screw installed in front and rear -center of Machine Base will serve as Leveling Screws; while two (2) Screws installed in front-corners of Machine Base will serve only as Support Screws.

Move Machine to desired location and placed leveling bolts over the center hole of the Leveling Pad. Be certain to allow sufficient clearance to allow access for leveling and also for connecting air and electrical lines. Lower machine onto leveling pads making certain that the leveling bolts align into counterbore on leveling pads.

Be certain nothing interferes with air or electrical lines running from the floating head assembly to the cabinet. Determine there is no possibility of air or electrical lines dragging on wall surfaces or adjacent machinery.

Wipe top Rails with a clean, dry cloth to remove protective shipping oil.



Do not attempt to move the Work Head unless Air Supply is connected, and air valve is turned on, and foot Pedal is depressed, allowing Head to float on Rails apply (WD40) or similar degreaser and flow the work Head side by side to remove all the shipping oil from under the work head. (Top Upper surfaces rails should be clean and free of oil).

### Removing shipping brackets

Before leveling the machine, loosen and remove the all shipping brackets and bolts. (Figures 1 – 5)

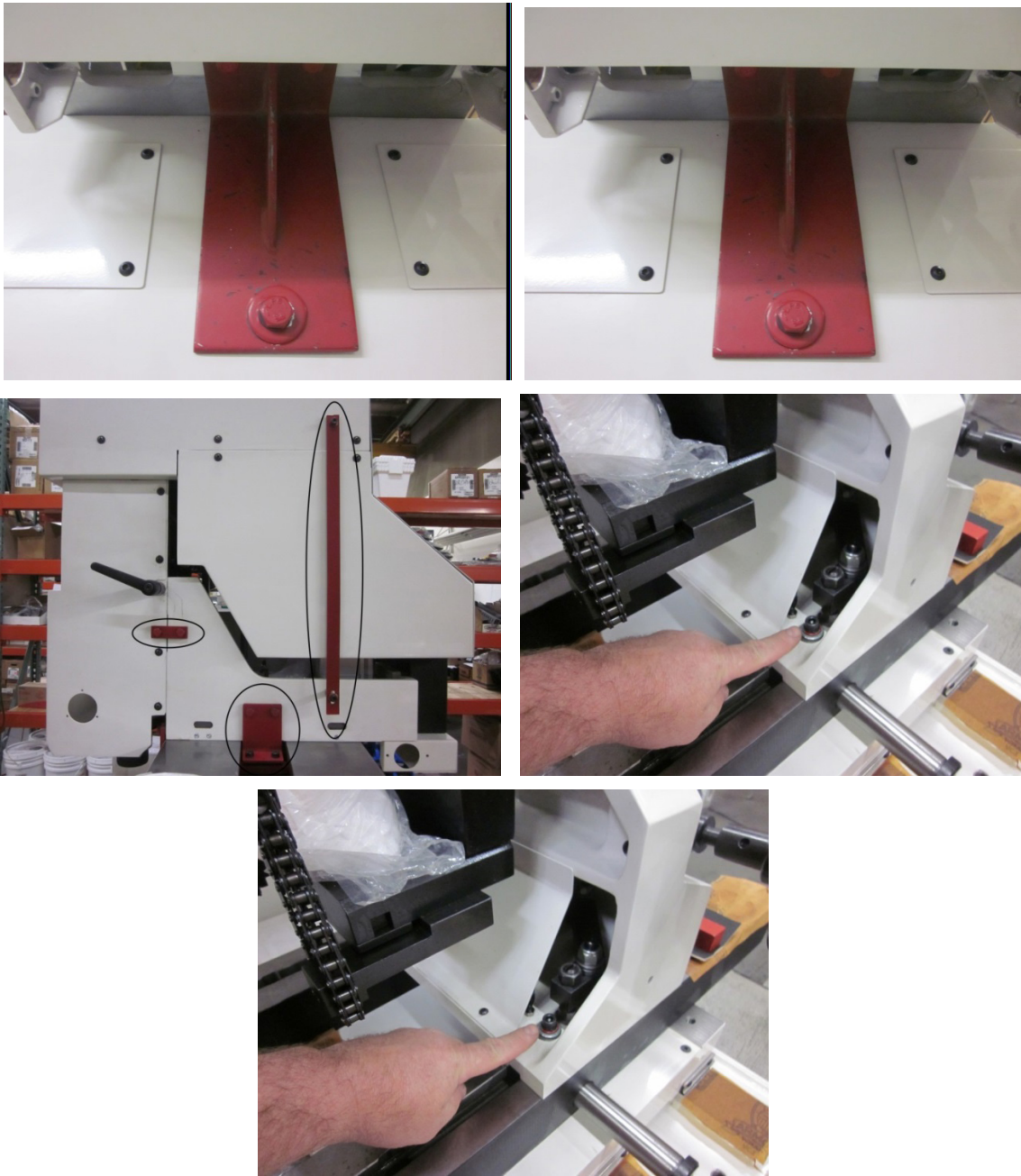

## Leveling the Machine

Use required machinist level. (Starret 98 or better).

NOTE: Rotate Level 180° to check that Level is properly adjusted. If Level does not read same in both directions, recalibrate level.



Use the level on the upper float surface, level the machine as precisely as possible, front to back and side to side.

Adjust 4 corners until level and then extend the 2 center leveling bolts to support machine. Tighten jam nuts on leveling bolts and recheck level



## Air Supply

It is very important the air source for the SG80M machine be moisture free. Water and oil in the line will result in early cylinder and valve failure. The factory recommends installing a water trap at the machine.

Attach a 100 PSI air source to the appropriate intake pictured, located on the lower left side of the machine.

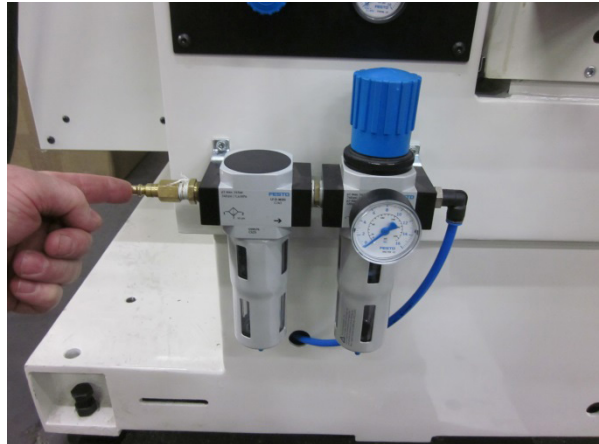

## Air Adjustments



## Float

The float regulators are located on the left side of machine base. Marked "Work Head Air Float Adjustment" If the work head is not floating properly it could be from too much or too little air from the regulator. Starting with all regulators set at 1 bar with "workhead float" button activated, slowly turn all up .5 bar at a time until workhead start to float. Pushing work head front to rear checking for stiff spots. If workhead is dragging in the forward position, (workhead pulled closest to operator) raise the 2 front regulators 1 mark until it floats without dragging. Same for rear. You may have to go back and forth a few times to get this correct. If workhead is not dragging lower the PSI until it does and then raise 1 notch at a time until it is free. Typically the front two regulators will be slightly higher than the rear two. Once the correct float is established lock the regulators in place by pushing in on the blue adjusting knob.

**CAUTION** Use as little air as possible to achieve correct floatation. Using too much air will / could cause excessive movement of workhead.

## Power Supply

This machine has the following power requirements:

208 to 240 VAC it shut not exceed 240 Volts

Single Phase

50 or 60 Hertz

30 amps

See illustration below for correct connection of “measured” incoming power. Connect single phase wiring to the main rear enclosure, located on the right rear of machine base. The connection point for power is located inside the enclosure. The connection termination point is the power switch. Connect L1 to the number 2 terminal, L2 (neutral) to the number 4 terminal.

**IMPORTANT** Electrically connect in accordance with national and local electrical codes.

## Grounding

This machine must be connected to a good earth ground rod. A 6 foot, 1/2” diameter, 15 OHM, Copper grounding rod driven into the earth next to the machines is preferred. Not providing a grounding rod could void factory warranty.

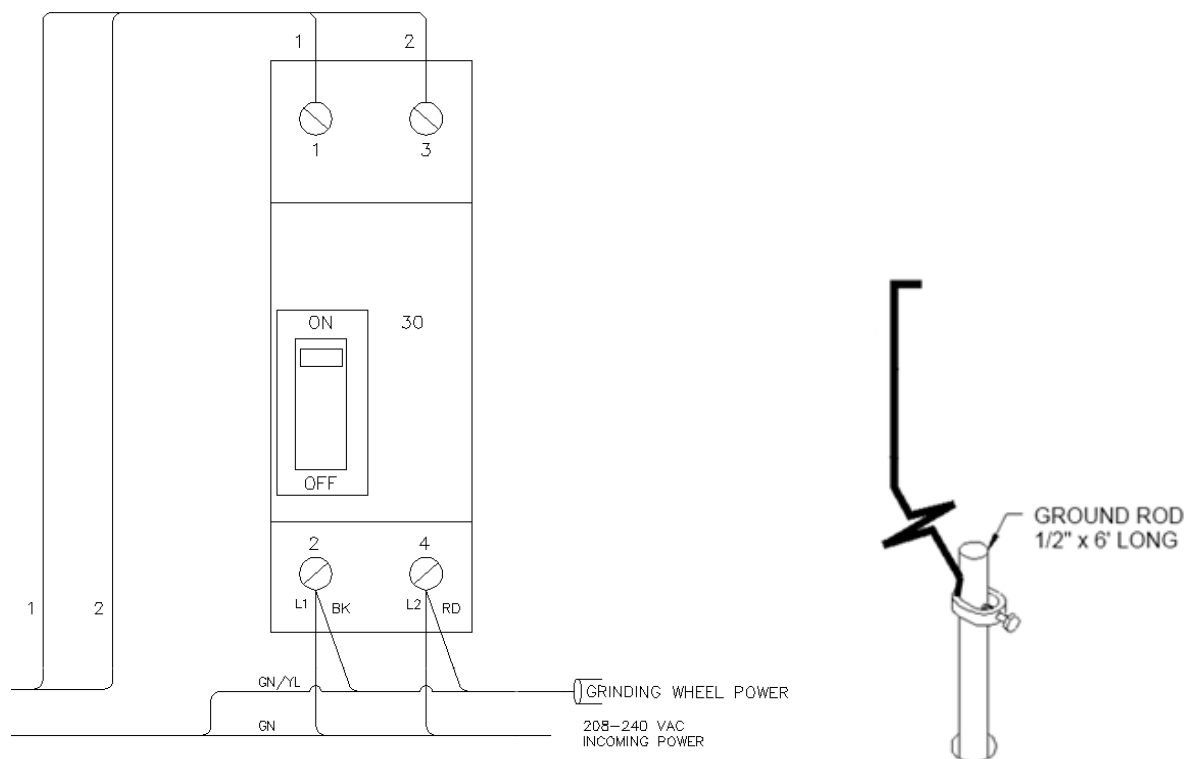



This page intentionally left blank



# SAFETY

## Contents

<b>Safety Information .....</b>	<b>3-1</b>
<b>Safety Instructions for Machine Use .....</b>	<b>3-1</b>
<b>Electrical Power .....</b>	<b>3-3</b>
<b>Machine Operator .....</b>	<b>3-4</b>
<b>Emergency Procedure .....</b>	<b>3-5</b>

## Safety Information

For Your Own Safety Read This Instruction Manual Before Operating This Machine.

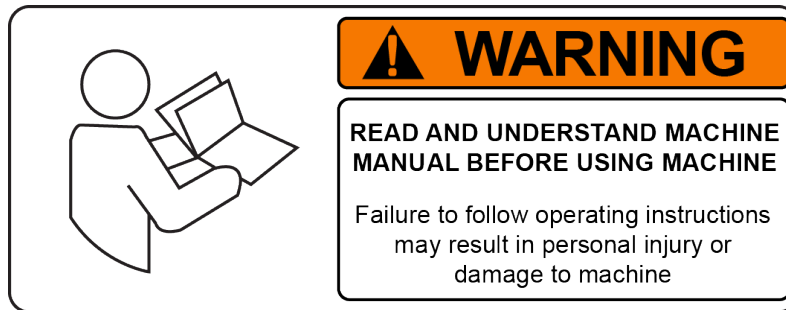

This is the safety alert symbol. It is used to alert you to potential personal injury hazards. Obey all safety messages that follow this symbol to avoid possible injury or death.



**DANGER** indicates an imminently hazardous situation which, if not avoided, will result in death or serious injury.



**WARNING** indicates a potentially hazardous situation which, if not avoided, could result in death or serious injury.



**CAUTION** indicates a potentially hazardous situation which, if not avoided, may result in minor or moderate injury.



**CAUTION** used without the safety alert symbol indicates a potentially hazardous situation which, if not avoided, may result in property damage.

### Safety Instructions for Machine Use



**This machine is capable of causing severe bodily injury**

**ONLY A QUALIFIED, EXPERIENCED OPERATOR SHOULD OPERATE THIS MACHINE. NEVER ALLOW UNSUPERVISED OR UNTRAINED PERSONNEL TO OPERATE THE MACHINE.** Make sure any instructions you give in regards to machine operation are approved, correct, safe, and clearly understood. Untrained personnel present a hazard to themselves and the machine. Improper operation will void the warranty.

**KEEP GUARDS IN PLACE** and in proper working order. If equipped with doors, they must be in the closed position when the machine is in operation.



**KEEP WORK AREA CLEAN.** Cluttered areas and benches invite accidents.

**KEEP CHILDREN AND VISITORS AWAY.** All children and visitors should be kept a safe distance from work area.

**WEAR THE PROPER APPAREL.** **DO NOT** wear loose clothing, gloves, rings, bracelets, or other jewelry which may get caught in moving parts. Non-Slip foot wear is recommended. Wear protective hair covering to contain long hair.

**ALWAYS USE SAFETY GLASSES.** Also use face or dust mask if cutting operation is dusty. Everyday eye glasses only have impact resistant lenses, they are NOT safety glasses.



**DO NOT OVER-REACH.** Keep proper footing and balance at all times.

**USE THE RECOMMENDED ACCESSORIES.** Consult the manual for recommended accessories. The use of improper accessories may cause risk of injury.

**CHECK DAMAGED PARTS.** Before further use of the machine, a guard or other part that is damaged should be checked to determine that it will operate properly and perform its intended function. Check for alignment of moving parts, breakage of parts, mounting, and other conditions that may affect its operation. A guard or other part that is damaged should be properly repaired or replaced.

**NEVER OPERATE A MACHINE WHEN TIRED, OR UNDER THE INFLUENCE OF DRUGS OR ALCOHOL.** Full mental alertness is required at all times when running a machine.

**IF AT ANY TIME YOU ARE EXPERIENCING DIFFICULTIES** performing the intended operation, stop using the machine! Then contact our service department or ask a qualified expert how the operation should be performed.

**DO NOT MODIFY OR ALTER THIS EQUIPMENT** in any way. If modifications are deemed necessary, all such requests must be approved and/or handled by Rottler Manufacturing. Unauthorized modifications could cause injury and/or damage to machine and will void the warranty.

**SAFETY DECALS SHOULD NEVER BE REMOVED.** They are there to convey important safety information and warn of potential hazards.

**ALL LOCAL SAFETY CODES AND REGULATIONS** should be followed when installing this machine.

**ONLY QUALIFIED PERSONAL** should perform service on the electrical and control systems.

When boring the machine is capable of throwing metal chips over 10- feet from the cutting area. Always use the guards. Eye protection must be worn at all times by the operator and all other personnel in the area of the machine.



**CAUTION** No list of safety guidelines can be complete. Every piece of shop environment is different. Always consider safety first, as it applies to your individual working conditions. Use this and other machinery with caution and respect. Failure to follow guidelines could result in serious personal injury, damage to equipment or poor work results.

## Electrical Power

All electrical power should be removed from the machine before opening the rear electrical enclosure. It is recommended that the machine have a electrical LOCK-OUT device installed.

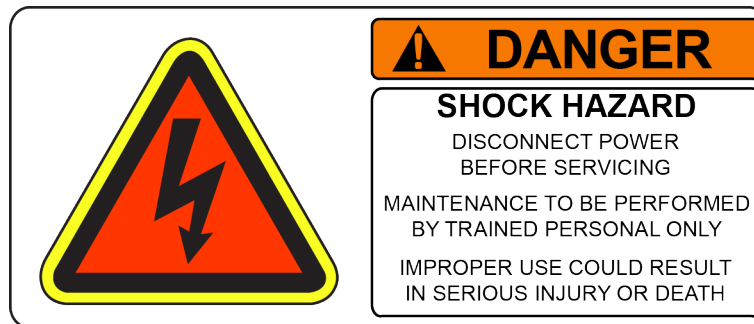



Make sure all electrical equipment has the proper electrical overload protection.

In the event of an electrical short, grounding reduces the risk of electric shock by providing a path of least resistance to disperse electric current.

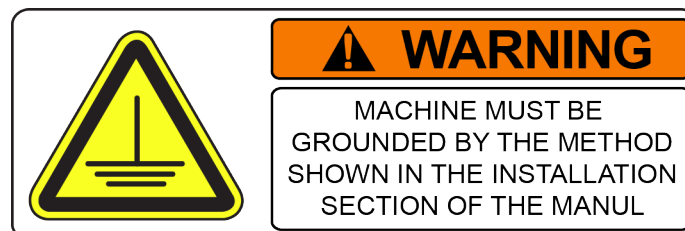
Electrocution or a fire can result if the machine is not grounded correctly. Make sure the ground is connected in accordance with this manual. DO NOT operate the machine if it is not grounded.



 **CAUTION** No single list of electrical guidelines can be comprehensive for all shop environments. Operating this machinery may require additional electrical upgrades specific to your shop environment. It is your responsibility to make sure your electrical system comply with all local codes and ordinances.

 **WARNING** This machine operates under computerized control and, as is all computerized equipment, and is susceptible to extraneous electrical impulses internally for externally produced. The machine may make moves out of the operator control at any time. The operator should work in and around the machine with caution at all times.

The operator and nearby personnel should be familiar with the location and operation of the Emergency Stop Button.

Make sure all electrical equipment has the proper overload protection. This machine should have **a fully isolated** power supply to prevent damage and uncontrolled movement of the machine. If this machine is on the same power lines that are running to other electrical equipment (grinders, welders, and other AC motors) electrical noise can be induced into this machines electrical system. Electrical noise can cause the controller to see false signals to move. Not supplying a fully isolated supply to the machine may void factory warranty. Refer to the Power supply section located in the Installation section for voltage and amperage requirements of this machine.

## Machine Operator

The operator of this machine should be a skilled machinist craftsman who is well versed in the caution, care, and knowledge required to safely operate metal cutting tools.

If the operator is not a skilled machinist he/she must pay strict attention to the Operating Instructions outlined in this manual, and get instruction from a qualified machinist in both production and operation of this machine.

This machine has the following areas of exposed moving parts that you must train yourself to respect and stay away from when they are in motion:

**Cutting Tool Area** – Any operation involving hands in the cutter head area, such as inspection or alignment of the cutter head or tools, changing Centering Fingers, tool insertion, and removal, cutter head changes, and size checking etc. requires the machine to be in Neutral.

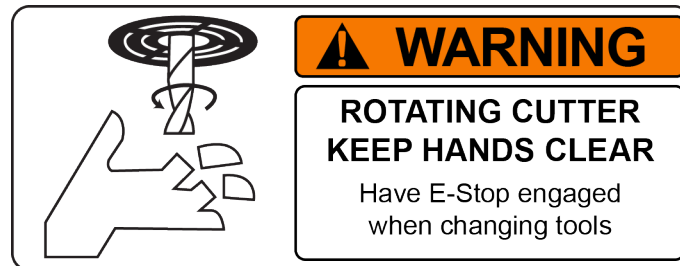

**Machining** – Eye protection must be worn during all operations of the machine. Hands must be kept completely away from the cutter head. All chip guards must be in position during machine operations.



**CAUTION** **Work Loading and Unloading** – Carefully develop handling methods of loading and unloading work pieces so that no injury can result if hoist equipment or lift connection should fail. Periodically check lift components for damage that may cause failure.

**CAUTION** **Machine Maintenance** – Any machine adjustment, maintenance or parts replacement absolutely requires a complete power disconnection from the machine, *this is an absolute rule.*

## Emergency Procedure

Assuming one of the following has occurred: tool bit set completely off size, work piece or spindle base not clamped, spindle is not properly centered, and these mistakes will become obvious the minute the cut starts

**PRESS THE EMERGENCY STOP BUTTON** (on the front control panel) **IMMEDIATELY!**

Find out what the problem is; return the spindle to its up position without causing more damage. To restart the machine, turn the Emergency Stop Button CW until the button pops out

Be alert to quickly stop the machine in the event of a serious disruption of the boring process either at the top or bottom of the bores.

**“REMEMBER”** metal cutting tools have the speed and torque to severely injure any part of the human body exposed to them.

# CONTROL DEFINITIONS

## SG80M Controls

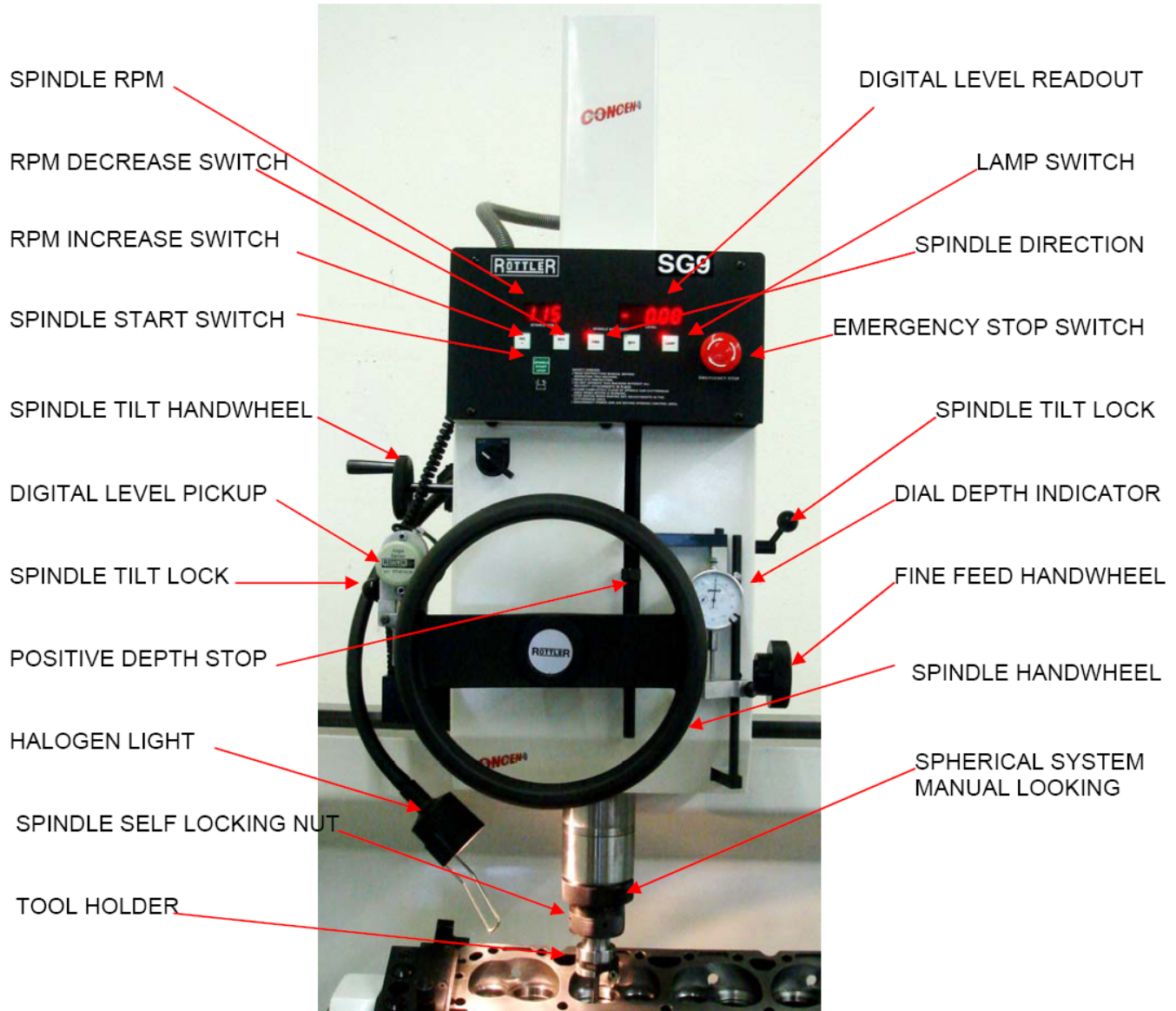

This page intentionally left blank



# OPERATING INSTRUCTIONS

## Contents

<b>Operating Instructions .....</b>	<b>5-1</b>
<b>Mounting Tool Sharpener .....</b>	<b>5-1</b>
<b>Rottler Tool Bit Sharpener .....</b>	<b>5-1</b>
<b>Built In Venturi Vacuum Tester .....</b>	<b>5-1</b>
<b>Mounting Cylinder Heads .....</b>	<b>5-2</b>
<b>2 Degree Tilt Fixtures .....</b>	<b>5-3</b>
Alignment and Setup .....	5-3
Front to Rear Cylinder Head Alignment.....	5-3
<b>Canted Valve Cylinder Heads (Automotive Application) .....</b>	<b>5-4</b>
<b>Multi Head Fixture .....</b>	<b>5-5</b>
Fixture Assembly .....	5-5
Installing Multihead Fixture On Machine .....	5-7
<b>Installing the Gearbox.....</b>	<b>5-11</b>
<b>Three Angle Seat Cutting.....</b>	<b>5-21</b>
<b>Checking Working Range of UNI-PILOT.....</b>	<b>5-22</b>
Checking Procedure .....	5-22
<b>Checking Valve Seat Concentricity.....</b>	<b>5-23</b>
<b>Machining Valve Seats And Counter Boring.....</b>	<b>5-24</b>
Aligning Spindle to Work .....	5-24
Changing the Spindle Adapters.....	5-24
Installing The Spherical Self Aligning Toolholder .....	5-24
Fine Feed Engagement.....	5-24
<b>SG80M Control Panel .....</b>	<b>5-25</b>
<b>Safety Tips Before Proceeding .....</b>	<b>5-25</b>
<b>Operation Tips Before Machining Valve Seats .....</b>	<b>5-26</b>
<b>Valve Seat Machining Procedure .....</b>	<b>5-26</b>
<b>UNIPILOT Centralizing Pilots .....</b>	<b>5-27</b>

<b>Pilot Diameter .....</b>	<b>5-27</b>
<b>Shank Diameter .....</b>	<b>5-27</b>
<b>Extended Length (EL) Pilots.....</b>	<b>5-27</b>
<b>Carbide Inserts .....</b>	<b>5-28</b>
<b>Special Profiles .....</b>	<b>5-28</b>
<b>Rottler Six and One Instructions.....</b>	<b>5-29</b>
<b>Adjusting the Square Carbide Inserts .....</b>	<b>5-32</b>
<b>Cutting Small Diameter Valve Seats .....</b>	<b>5-33</b>

## Operating Instructions

### Mounting Tool Sharpener

Mount tool sharpener on right hand side of machine using the cap screw provided with machine.

### Rottler Tool Bit Sharpener

When you sharpener the Rottler form Carbide bits, consists in restoring the tool cutting angle by grinding the face.

To sharp the carbide bit must be fitted on the bit holder also fitted on the tool holder.

The tool holder will be placed on the adjustable 3/8 fixture of the tool sharpener.

Slide the tool holder on the fixture, and release the adjusting knob.

Adjust the fixture to bring the carbide bit flat against the grinding wheel.

Make sure the carbide tip face is perfectly parallel to the wheel face by pushing it with the thumb.

Once a good setting is achieved, lock the adjusting knob.

Before to start the grinding motor, move the carbide bit away from the wheel by rotating the tool holder.

The motor should then be started and the carbide tip face will just be cleaned.

There is no need to remove a lot of stock from the carbide bit. Sharpening only consists in providing a new cutting face.



### Built In Venturi Vacuum Tester

Designed to test valve seat and seat surface seal, and particularly to measure the valve seat surface quality after machining. Including a set of 7 pads and connecting extension to fit must common ports.



## Mounting Cylinder Heads

Initial clamp height adjustments to the head trunions can be accomplished by measuring the head thickness then raising the turning clamping block assembly to the appropriate height using the clamping block acme screws. A 10mm T - handle allen wrench works well.

### Roll Over Fixture with Safety Chains for Large Cylinder Heads

Measure the length of the cylinder head. Spread the trunion assemblies apart from each other so that the cylinder head can be clamped in between the trunions.

Each support has an adjustable stop, located to the front. The stops have indents, allowing a number of different settings. Position of the stops must be checked for each cylinder head put on the supports. In most cases we will install the cylinder head deck side down with the exhaust side of the head against the adjustable stops. This is particularly true of wedge style heads. It is necessary for the clamps to thrust the cylinder head against the stops when clamped. When heads are mounted in this fashion, the tallest portion of the combustion chamber will be at the rear of the machine when the head is rotated into the working position. Try to keep the valve guide center line parallel to the trunion centerline. A Safety chain has been added to this fixture to keep the head from dropping while you're working with large and heavy cylinder heads.

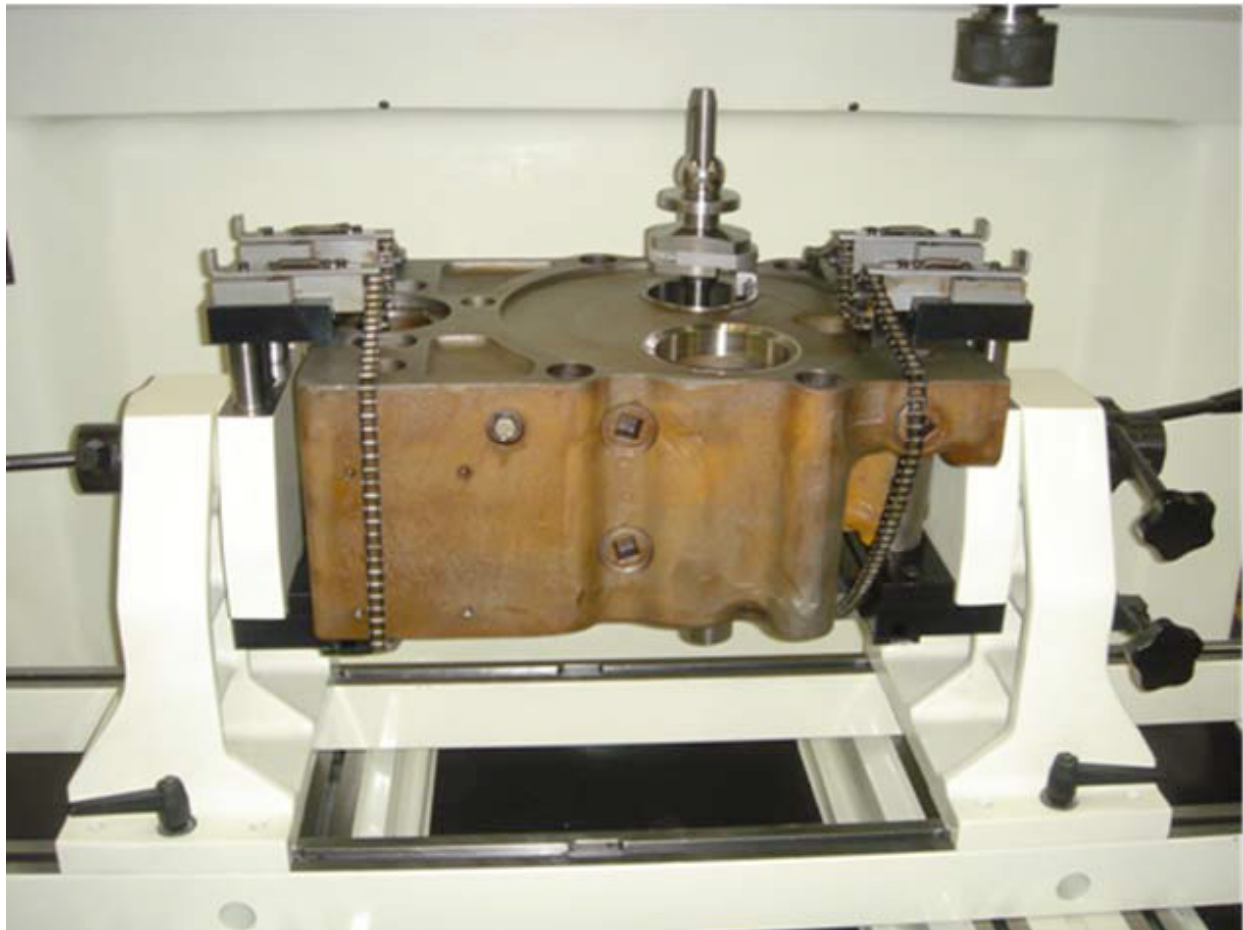

## 2 Degree Tilt Fixtures

Tilt Fixtures for large cylinder heads applications including adjustable base plate, Set of two 2" and 4" parallels; it required one set of Clamp Towers (7242N)

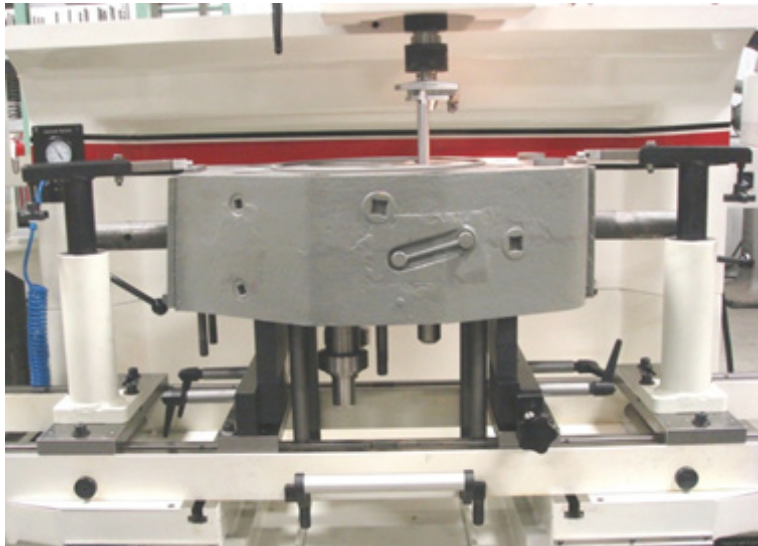

### Alignment and Setup

Alignment and setup applies to both the cylinder head and the machine's floating head. The goal is to perfectly align the spindle centerline to the centerline of the area of the head to be machined. Most machining operations on cylinder heads use the valve guide centerline as the reference point so we will use that as an example.

**Note: think of the digital electronic level as a comparator. Because the leveling pin is square to the machines spindle, as long as you achieve the same readings front to rear and side to side then the spindle will be in perfect alignment.**

### Front to Rear Cylinder Head Alignment

Position the level on level pin to read front to rear and take a reading. Rotate the cylinder head so that the valve seats are facing up. Now place the level on a pilot in the cylinder head and position the level to read front to rear. Loosen the lock levers on the supports. Be certain the fine adjustment lock screw is loosened. Coarse adjustment is made by turning the work piece manually, until the level reading is within a couple of degrees of the reading on the leveling post.





Lightly tighten the lock levers on the supports to remove any play. Now tighten the clamp on the fine adjustment screw. Turn the adjustment knob to achieve the exact reading that was observed on the leveling post. You can now completely tighten both the left and right support locks.



### Left to Right Alignment

Obtain the left to right reading from a pilot mounted in a guide in the cylinder head. Now place the level on the leveling post. Loosen both of the tilt lock levers on each side of the quill housing. Use the tilt adjusting hand wheel to adjust the reading to be the same as that found on the pilot in the cylinder head. Tighten the tilt lock levers.



### Canted Valve Cylinder Heads (Automotive Application)

An optional alignment bar is available that helps establish the front to back alignment on canted valve cylinder heads. The bar is held against two pilots in two adjacent guides. Use the alignment post to adjust the angle. (See Picture)

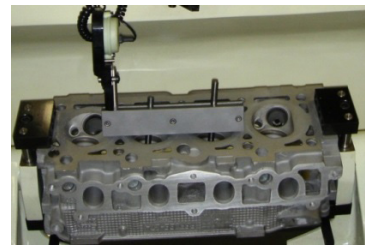

**Multi Head Fixture**

**Fixture Assembly**

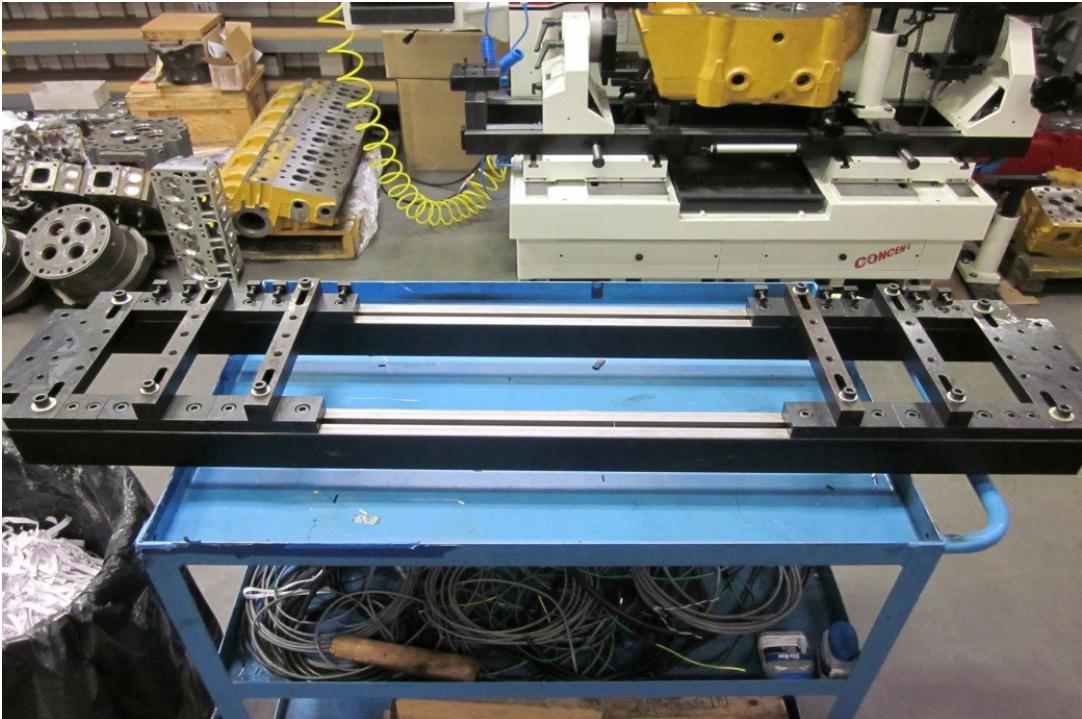



First install clamp bolts with 4 long on the outside. Next install clamp uprights (spacers on these can be removed for different head heights) and finally the clamps.

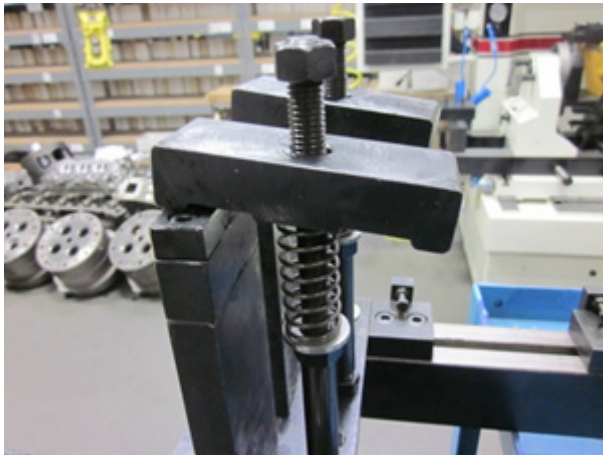
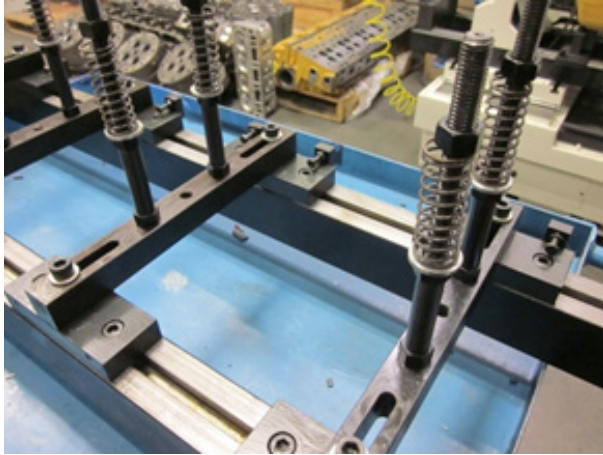

Completed Unit:

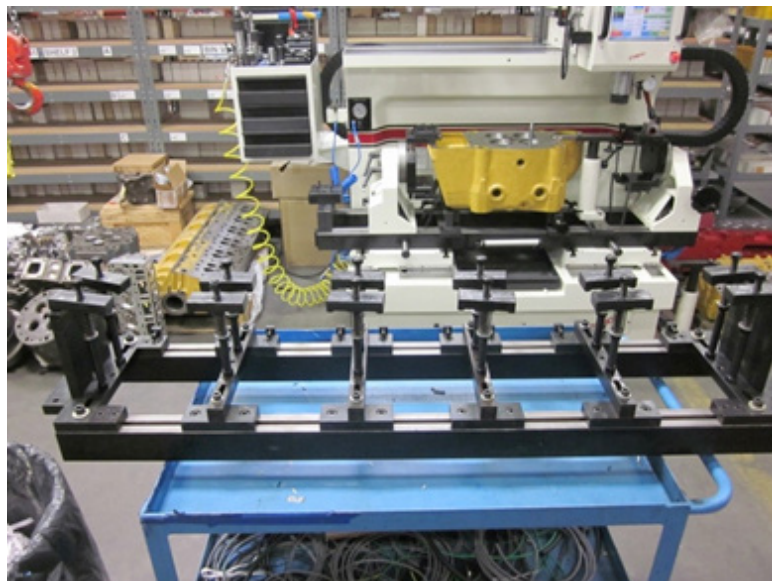



### Installing Multihead Fixture On Machine

First remove fixed plates from cradle assembly, then clamp plate. To remove clamp plate you must first remove this allen screw.

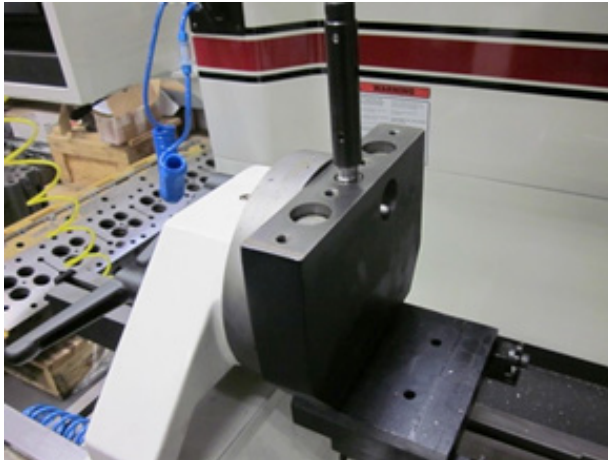

Then lift post off and remove keyway. Roll over and unscrew clamps to remove.

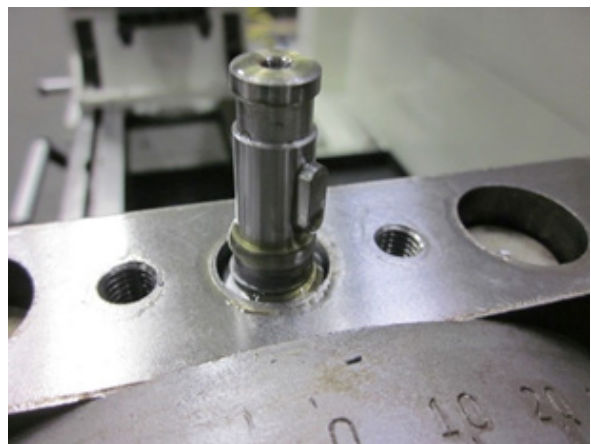

This is what you will have now.

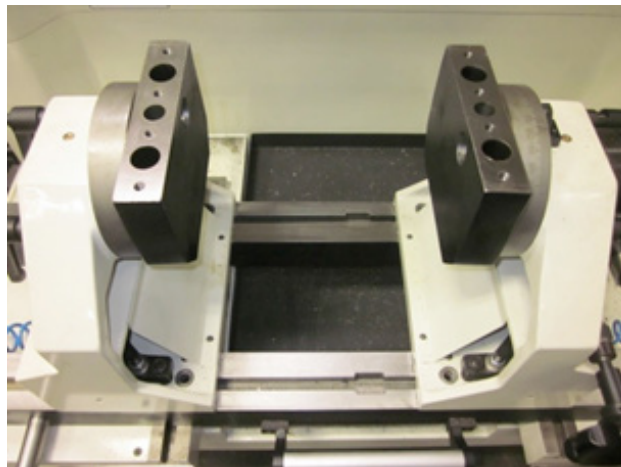

Remove end stoppers as cradles will hang over slightly. Be careful not to slide them off.

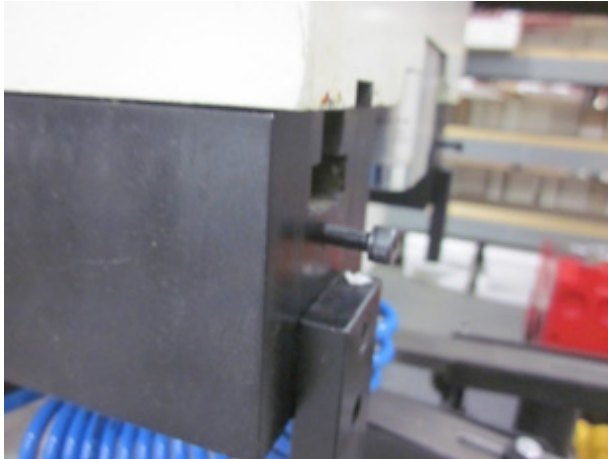

Move cradles to the far ends and lower assembly on and bolt down making sure the stoppers are facing you. Assembly must be flipped over to do this. Roll over for loading position.

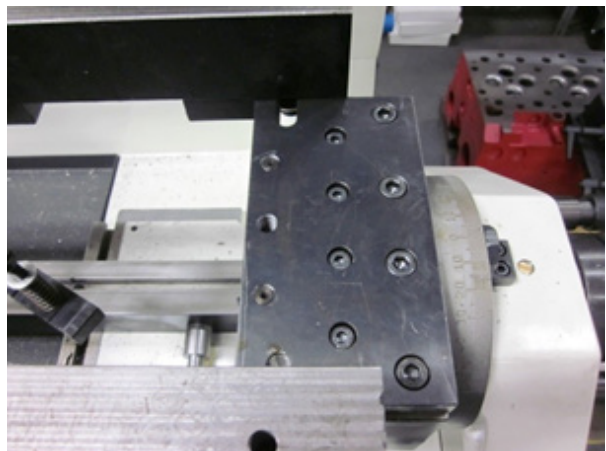
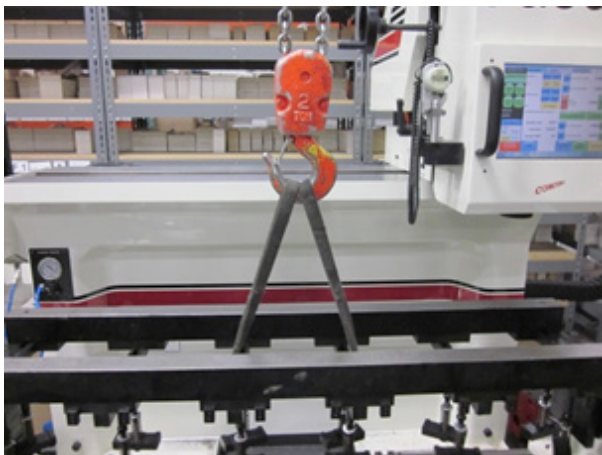

Head Stopper.

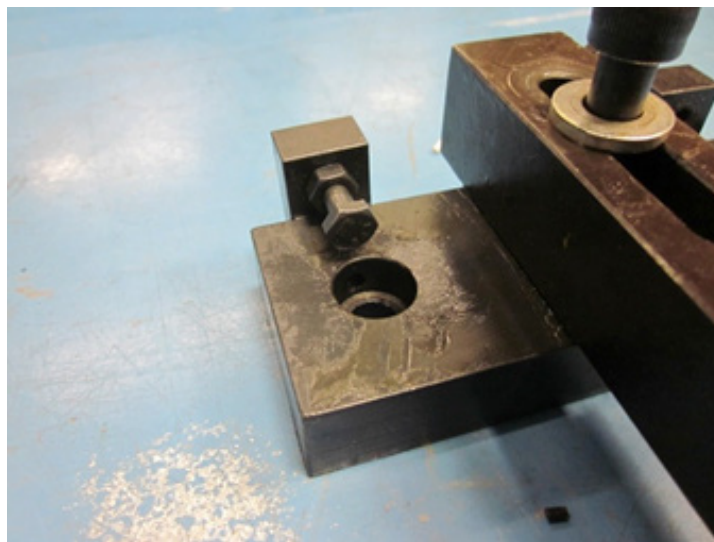



Cutting position



Loading position



You will need to adjust spacing according to the heads you are working on by loosening all 3 allen bolts on each end of clamp screw assemblies. There are end stoppers that can be adjusted also. Stoppers must be away from operator in loading position.



4 Cat 3500 heads in loading position.

4 Cat 3500 heads in cutting position





### Installing the Gearbox

Remove 4 bolts from retainer ring

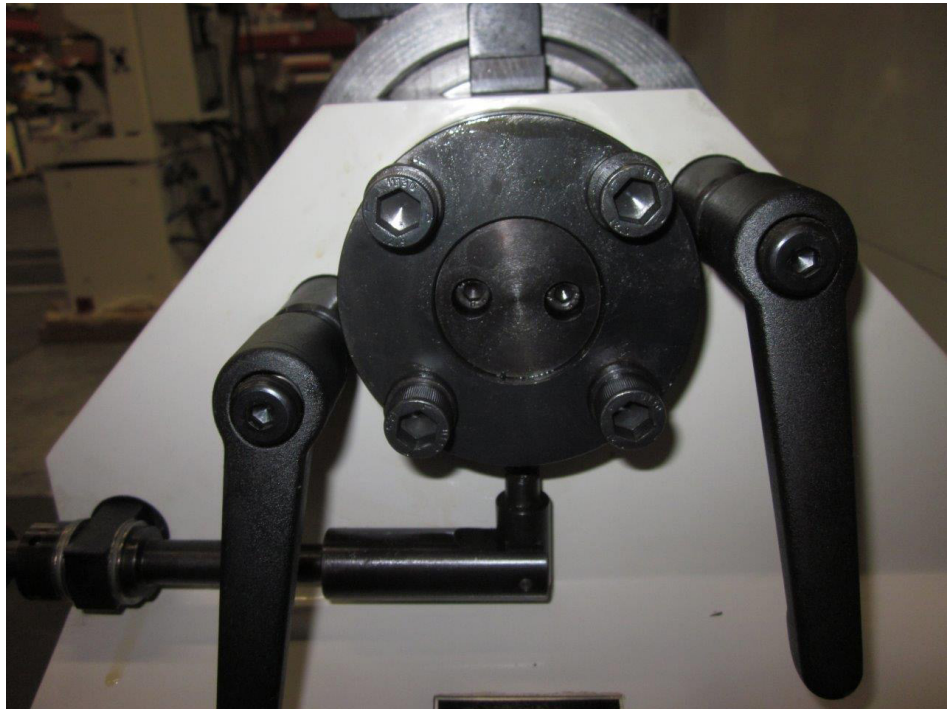

Remove 2 bolts from shaft cap



Remove ring and cap



Disassemble gearbox

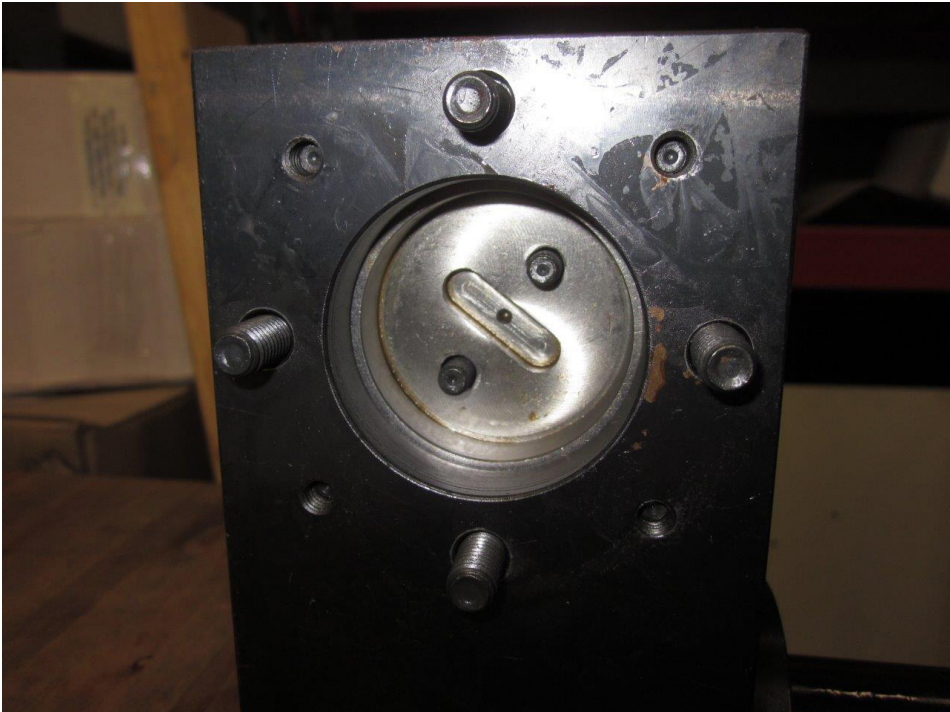



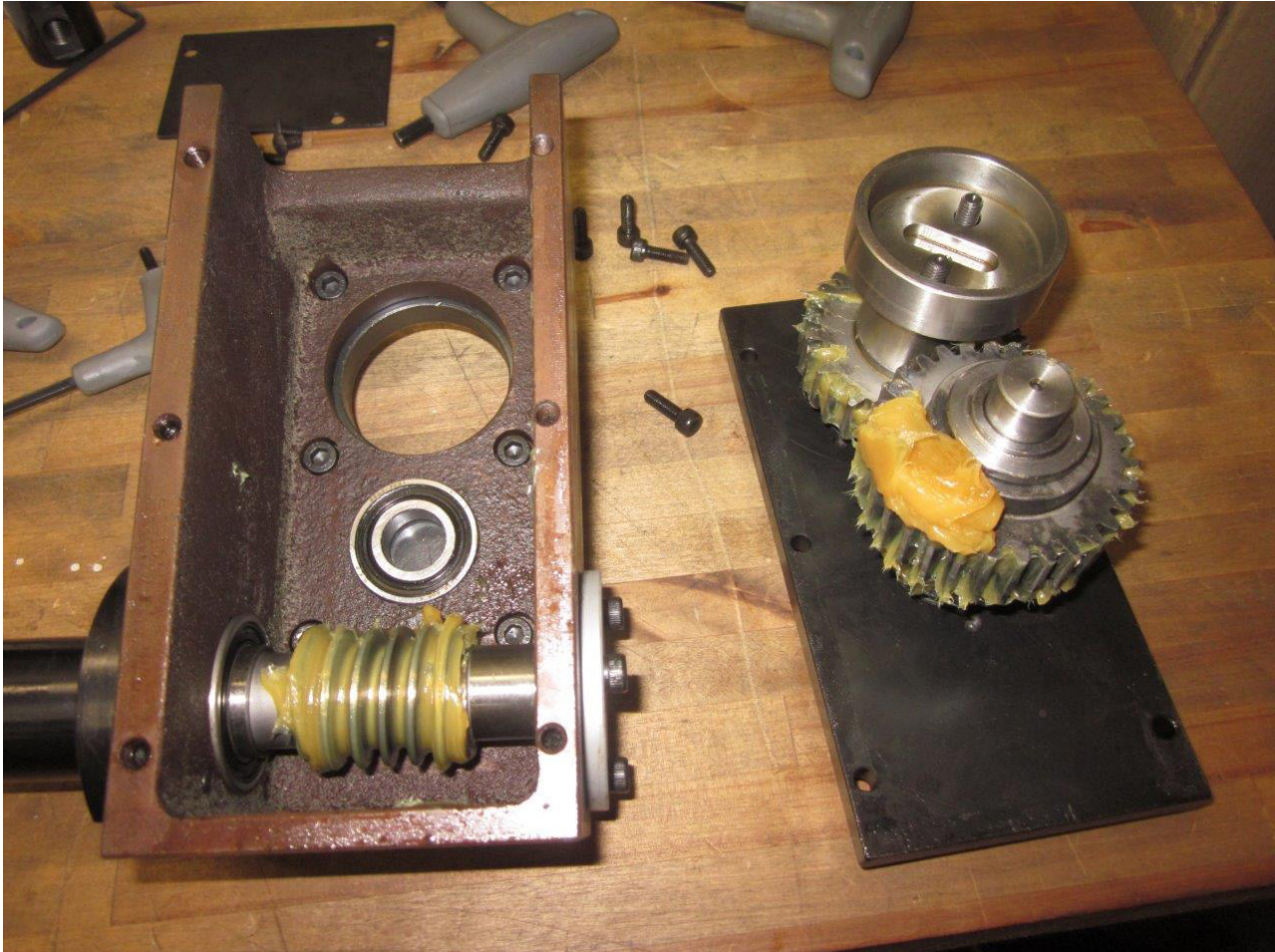
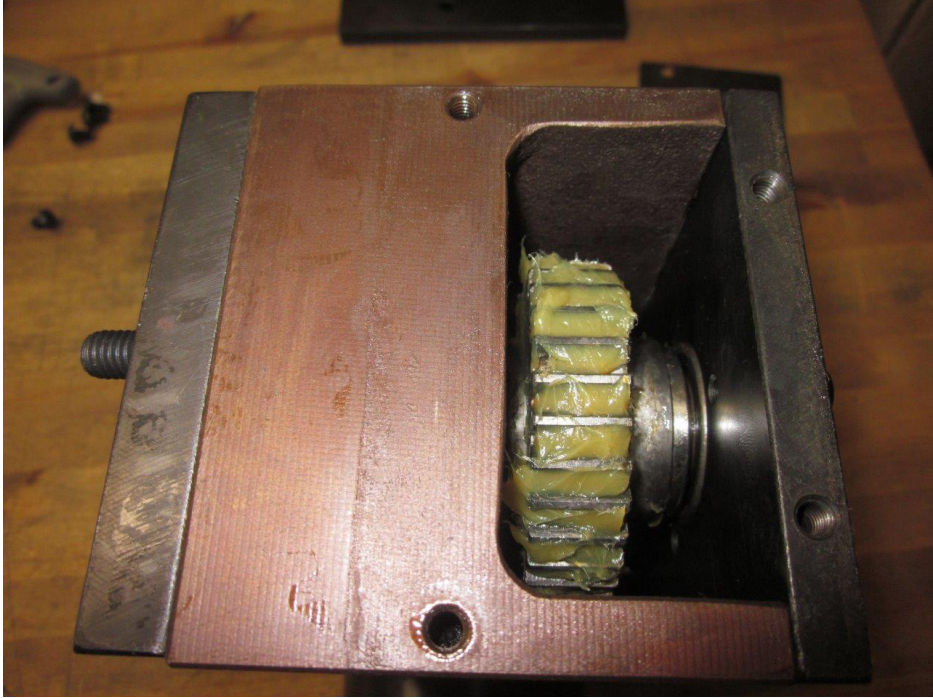



Take mount plate from gearbox and place on fixture

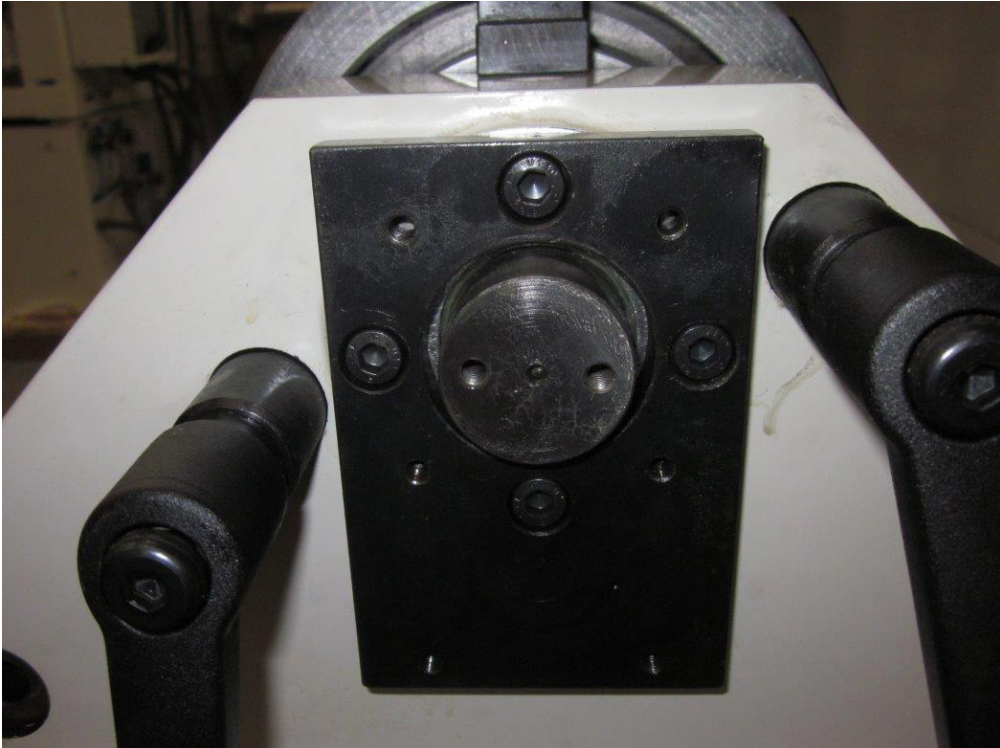



Remove shaft from gear as shown

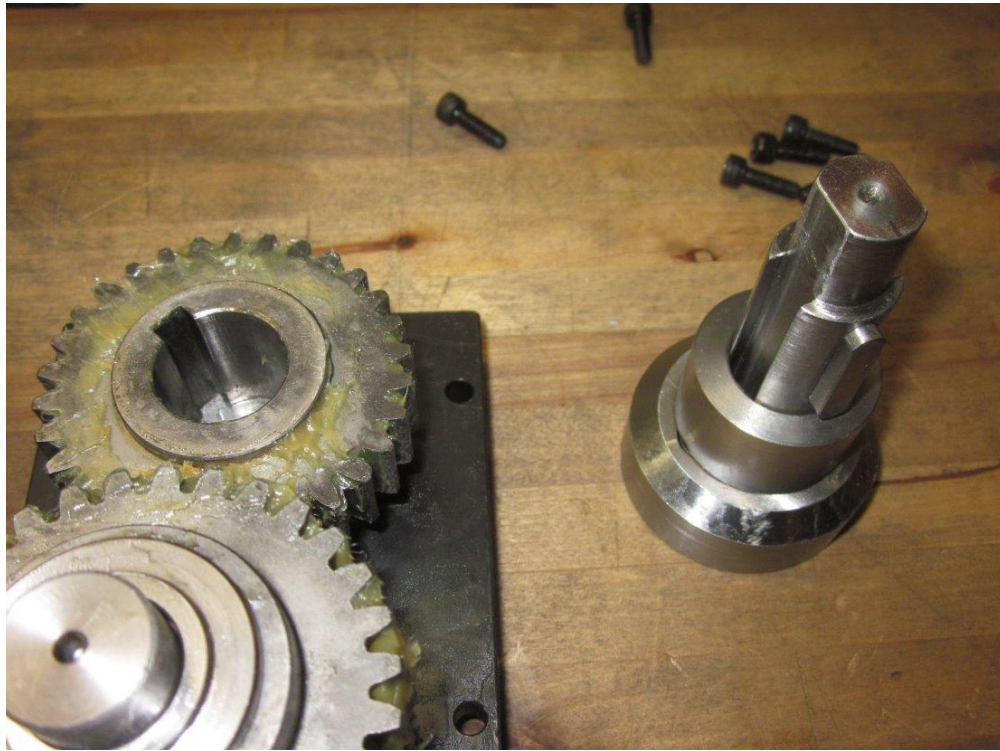

Remove key and spacer from shaft



Bolt gearbox shaft to fixture rotation shaft. Leave bolts loose.



Bolt gearbox housing to mount plate on fixture

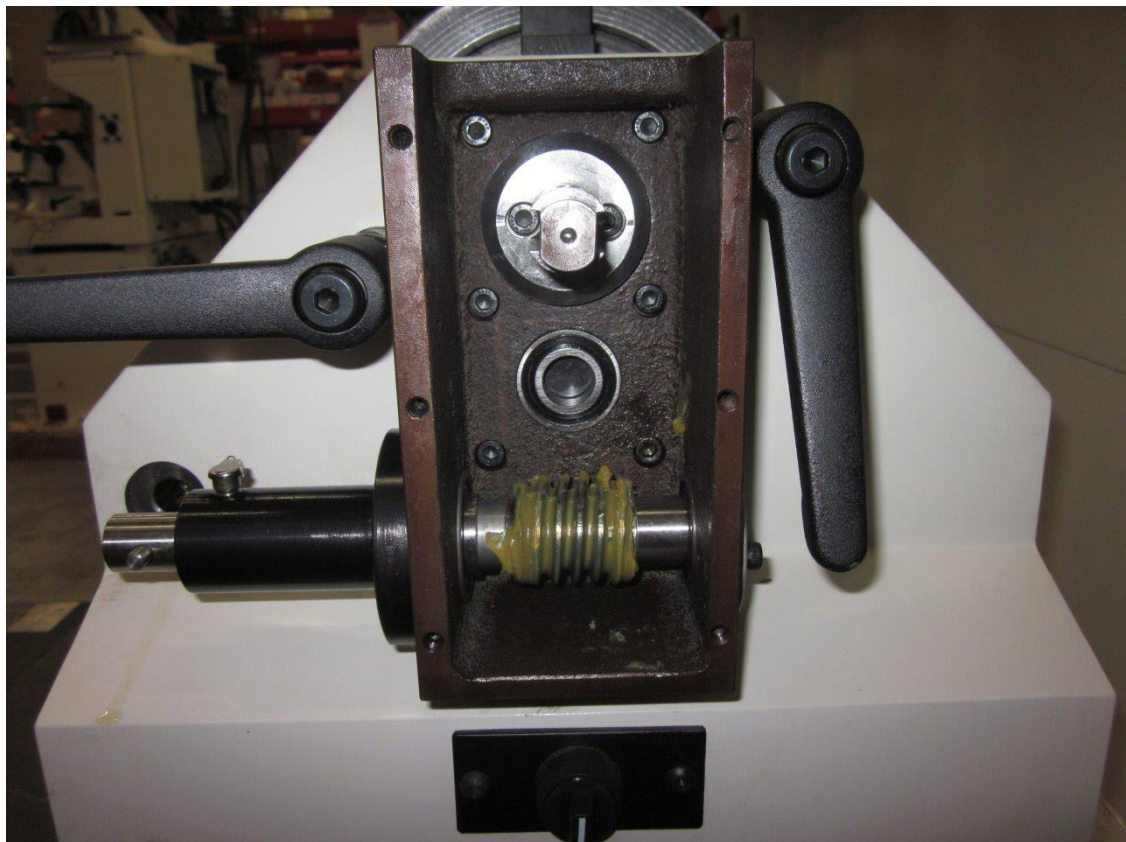



Install gearbox side cover to align shaft

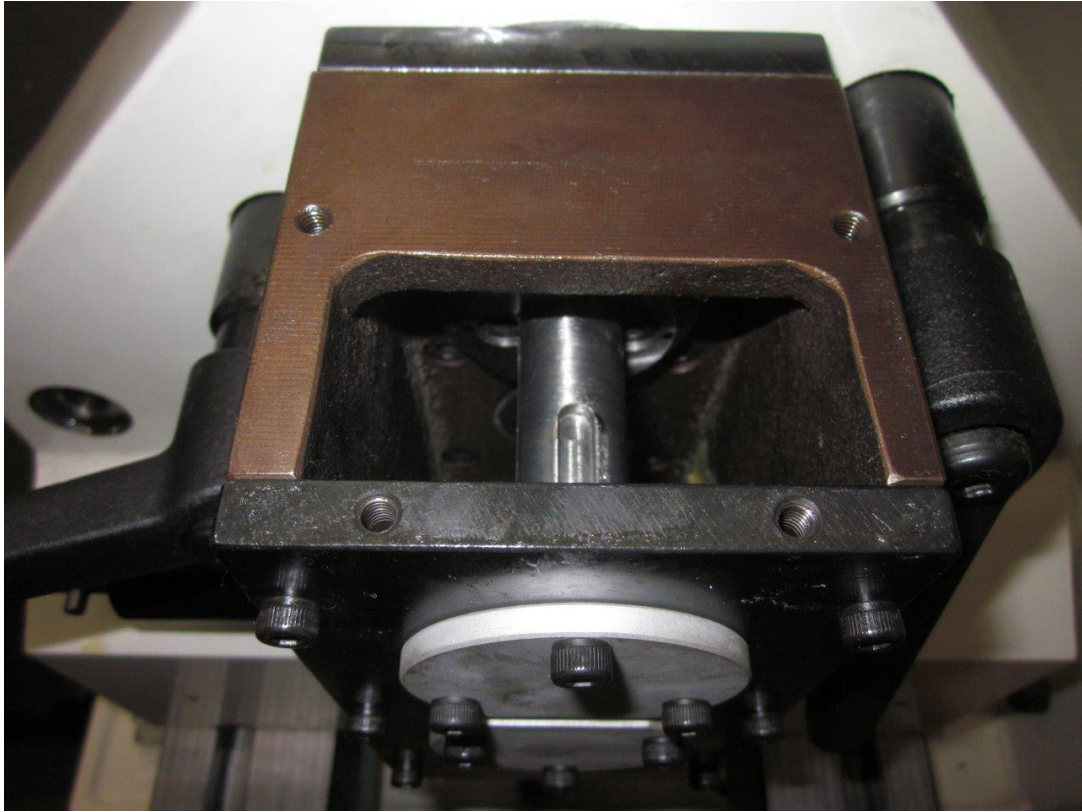

Tighten shaft bolts

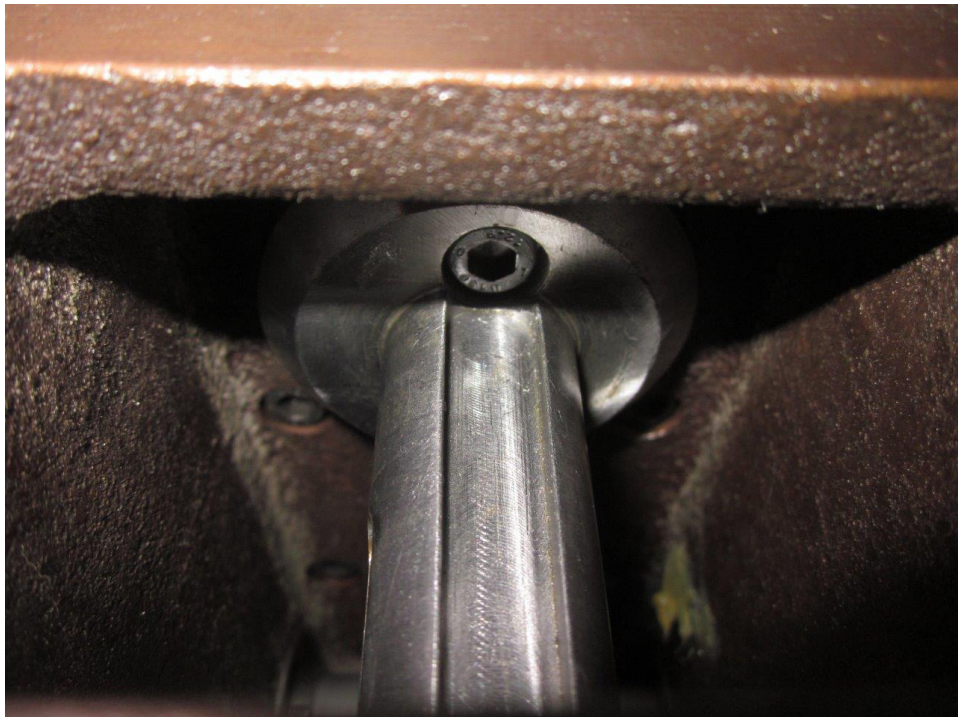

Remove side cover and reinstall spacer and key on shaft. Install gears

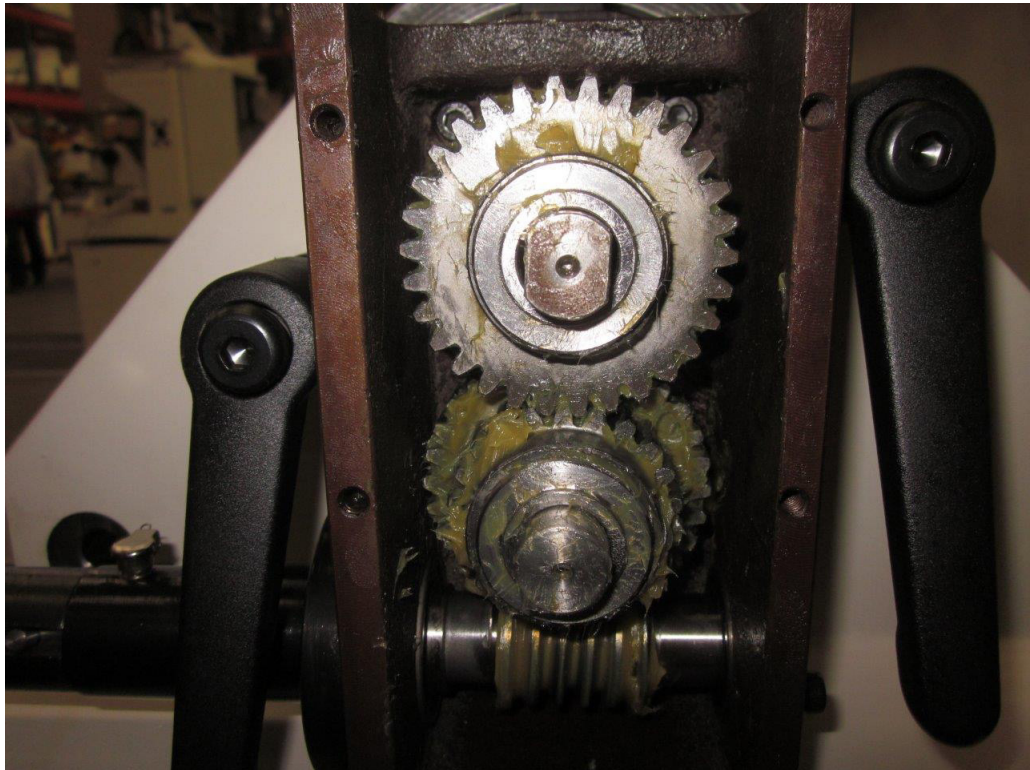

Install side cover





Install top cover

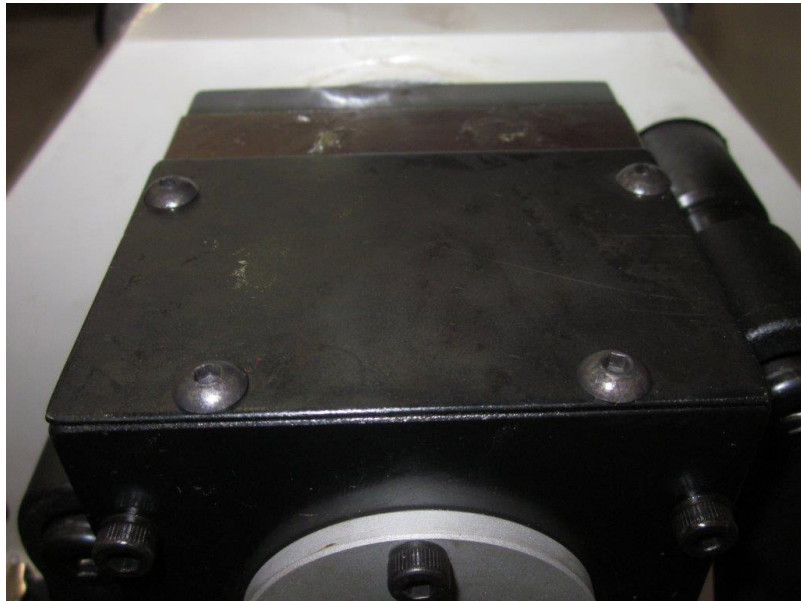

Assemble handle as shown



Install handle on gearbox

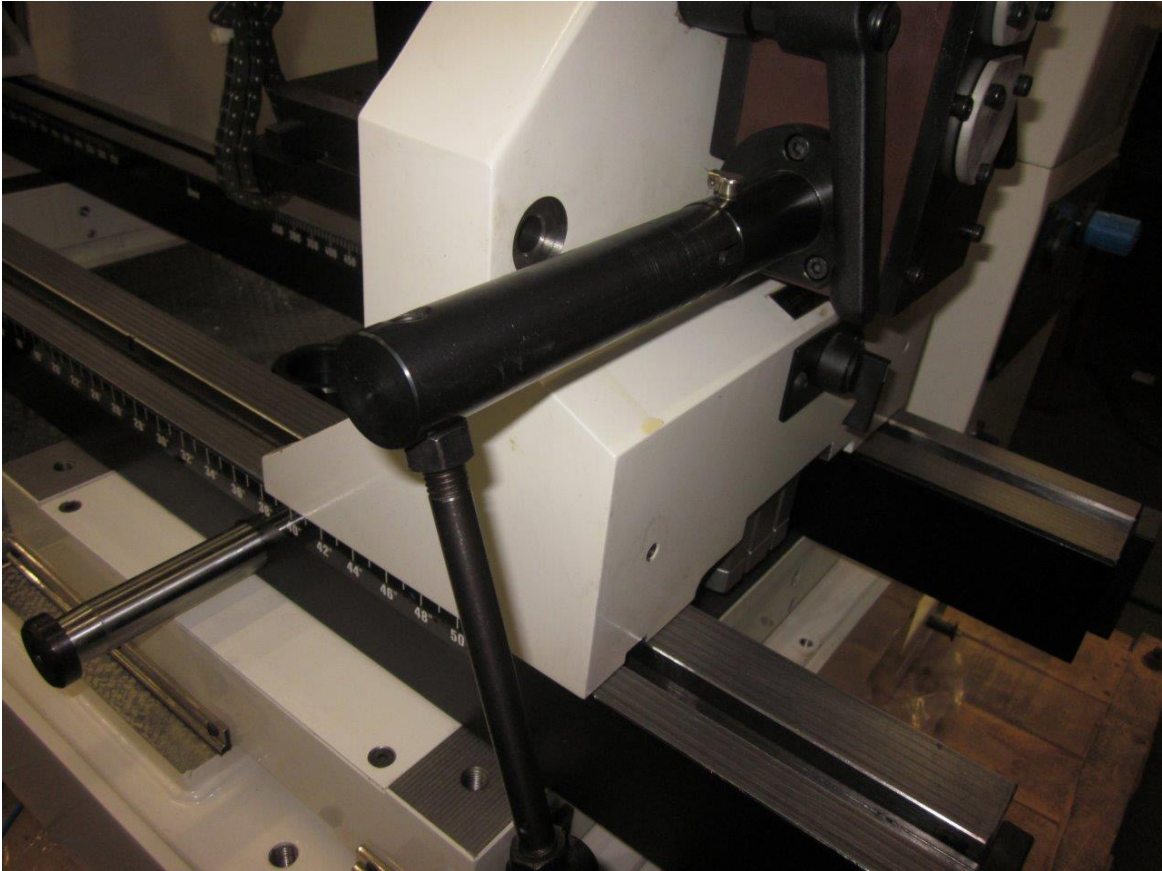

### Three Angle Seat Cutting

1. Place the ball drive adapter in the spindle.
2. Align spindle to valve guide.
3. Place a valve in the setting fixture. Position the pointer on the valve where you wish to place the top of the seat.
4. Remove the valve; replace it with the correct pilot.
5. Select the proper diameter tool holder. Place the carbide insert in tool holder. Slide tool holder onto ball head.
6. Place ball head over the pilot in setting fixture. Use radial adjusting screw to set diameter of cutter to correspond to position of pointer on setting fixture.
7. Tighten hex socket screws on bottom of ball head. See figure 9
8. Remove ball head assembly from setting fixture. Place fixed carbide pilot in cylinder head.
9. Center the spherical ball head toolholder over the pilot shank.
10. Required spindle rotation speed will vary, depending on seat hardness. As seat hardness increases, so does the required spindle speed. Some will require full speed.
11. Special care should be taken in centering the floating head above the valve guide, to achieve a concentric seat.
12. Cut seat only enough to clean up surface.

Too much cutting will sink the valve too far in the head. Many operators prefer to use the spindle fine feed when machining seats as extreme control of spindle down feed can be accomplished.

The capacity of the Rottler SG80M associated with a complete tooling range allow working on seats of diameters up to 210 millimeters (8.25").

Four tooling ranges are possible:

- 1) For seats diameters between 18 and 60 mm ( 0.71" - 2.4"): tool holder BH375R1 or UPTSH375R1 and tip holder TH2000 for seat range .710" - 1.180" (18mm-30mm) or TH2001 for seat range 1.100" - 1.570" (28mm-42mm) or TH2002 for seat range 1.570" - 2.360" (40mm-60mm), with 9,52 mm ( 3/8 ") pilots of shank diameter
- 2) For seats diameters between 40 and 80 mm (1,570" - 3.150"): tool holder BH375WR1 or UPTSH375WR1 and tip holder TH2003 for seat range . 1.570" - 2.360" (40mm - 60mm) or TH2004 for seat range 2.280" - 3.150" (58mm - 80mm), with pilots with 9,52 mm ( 3/8 ") shank diameter
- 3) For seats diameters between 60 and 110 mm (2,362" – 4.330"): tool holder BH20R and tip holder TH3005 or TH3006 for pilots with 20mm shank
- 4) For seats diameters between 95 and 150 mm (3.740" – 5.905): tool holder BH20RW and tip holder TH3007 or TH3008 for pilots with 20mm shank

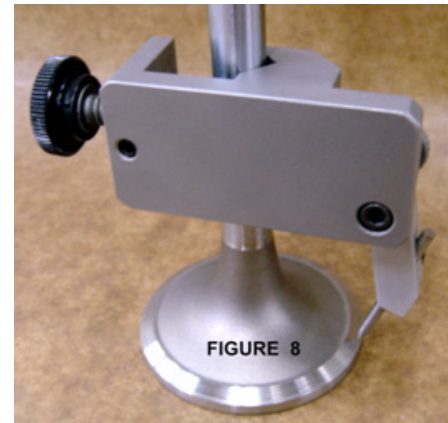



## Checking Working Range of UNI-PILOT

### Checking Procedure

1. Insert Standard 3/8 (9.52mm) Shank diameter UNI-PILOT in the cylinder head valve guide.
2. Place checking gauge along pilot section that is exposed above cylinder head surface.
3. If pilot top is within Min & Max range of the gauge, then you may proceed with machining seat.
4. If pilot top is above Max range on gauge a smaller diameter pilot must be used.
5. If pilot top is below Min range mark on gauge a larger pilot must be used.

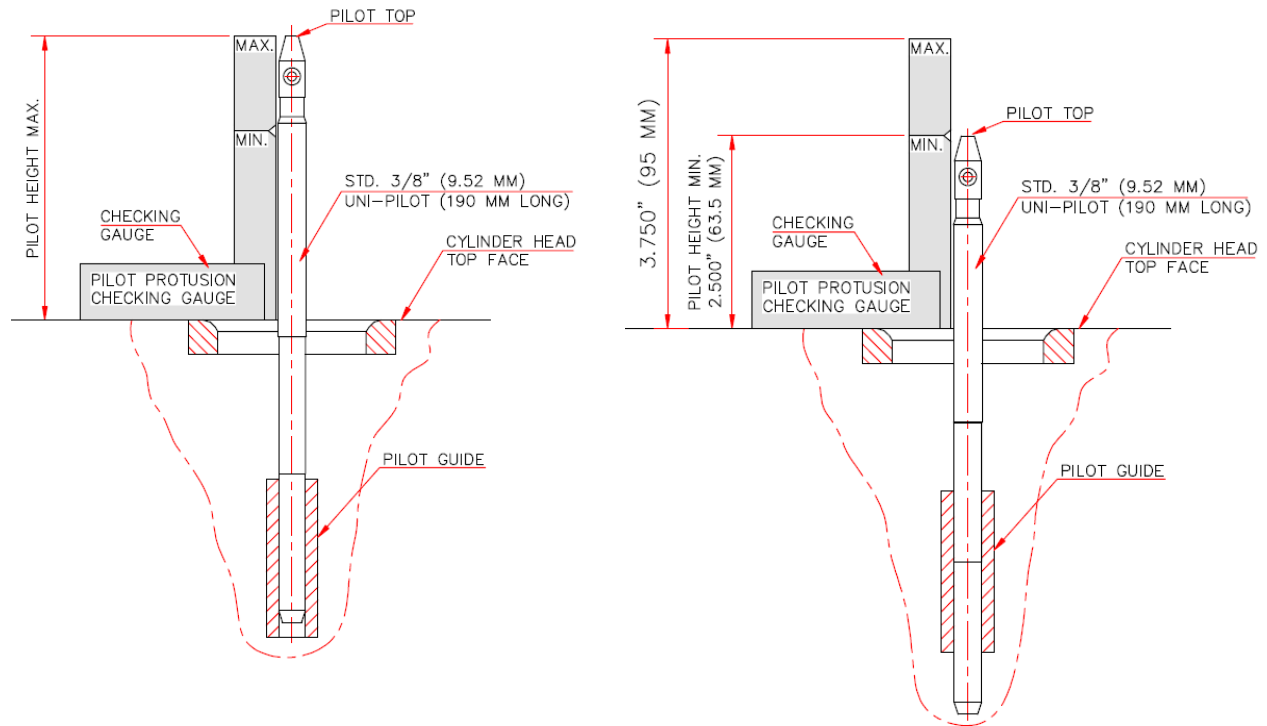

### Checking Valve Seat Concentricity

Make sure pilot and valve seat to be measured are free from dust, burrs, etc. A drop of oil or similar lubricant on valve seat will aid measuring. Loosen brass locking screw and lower dial gauge down over pilot. Make certain the tip of the probe is centered on the valve seat to be inspected.

Grasp brass frame in middle of gauge and move upward approximately 1/8". The dial pointer should move as this is done. Center the pointer of the indicator pointing upward and lock the gauge to the pilot using the brass locking screw. Test proper alignment by moving the brass frame up and down. The pointer should move.

Set the pointer at (0) by turning the dial face.

Inspect the seat run out by rotating the probe around the valve seat by twisting the knurled sleeve with your fingers. Each number on the dial indicator is equal to 0.001", (0.0254mm) run out of the valve seat. Each mark on the dial indicator is equal to 0.0001", (0.00254mm) run out of the valve seat.

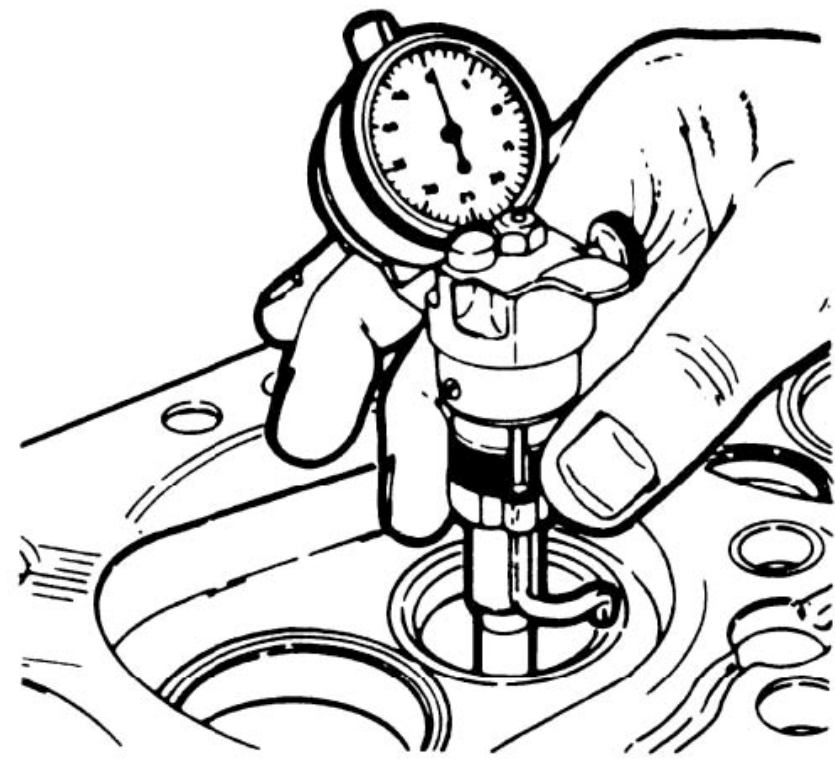

## Machining Valve Seats And Counter Boring

### Aligning Spindle to Work

Most machining operations require the spindle to be directly centered over the work to be performed. This is usually accomplished by air floating the work head above the area to be machined then manually lowering the spindle to engage the tooling that's going to be used. Most of the tooling used with the SG80M has been engineered with this centering feature incorporated into the design

**CAUTION** If the pedal is released too quickly, the floating head may bounce. True centering may not be achieved, if this happens. Slowly releasing the air float pedal gives the best results. Removing your hands completely from the work head during the final seconds of centering will insure that you do not negatively influence centering accuracy.

### Changing the Spindle Adapters

Once that you have the tool holder setup, fit the ball head tool holder into the spring free spindle adapter, or fit the UPT tool holder.

The SG80M spindle has been engineered to allow ultra fast tooling changes.

Make sure the that spindle spring free locking nut is in the off lock position, line up the two ears of the spindle adapter and insert into the spindle ISO 30 taper. The locking nut automatically will be on the lock position, to remove turn the self-locking nut to the left position, hold the spindle adapter, it may drop on the machine table. Damage will result.

### Installing The Spherical Self Aligning Toolholder

Once the spring free adapter is in the spindle, fit the Rottler Spherical Self aligning Toolholder assembly into the spindle adapter. Make sure to align the locator pins before you fit it into the spindle adapter and push it until you feel that it is locked

### Fine Feed Engagement

To engage the fine feed mechanism it is necessary to push inward on the spindle feed handwheel while rotating the fine feed handwheel until engagement is achieved. To disengage the fine feed simply pull outward on the spindle feed handwheel



**ROTTLER FINE FEED SYSTEM**  
BY PUSHING, THE MAIN  
HANDWHEEL (Steering Wheel)  
WILL ENGAGE THE FINE FEED  
SYSTEM. TO DISENGAGED,  
BACK OFF THE FINE FEED AND  
PULL OUT THE HAND WHEEL.

**RECOMMENDED WHEN USING  
THE FIXED PILOT SYSTEM**

## SG80M Control Panel

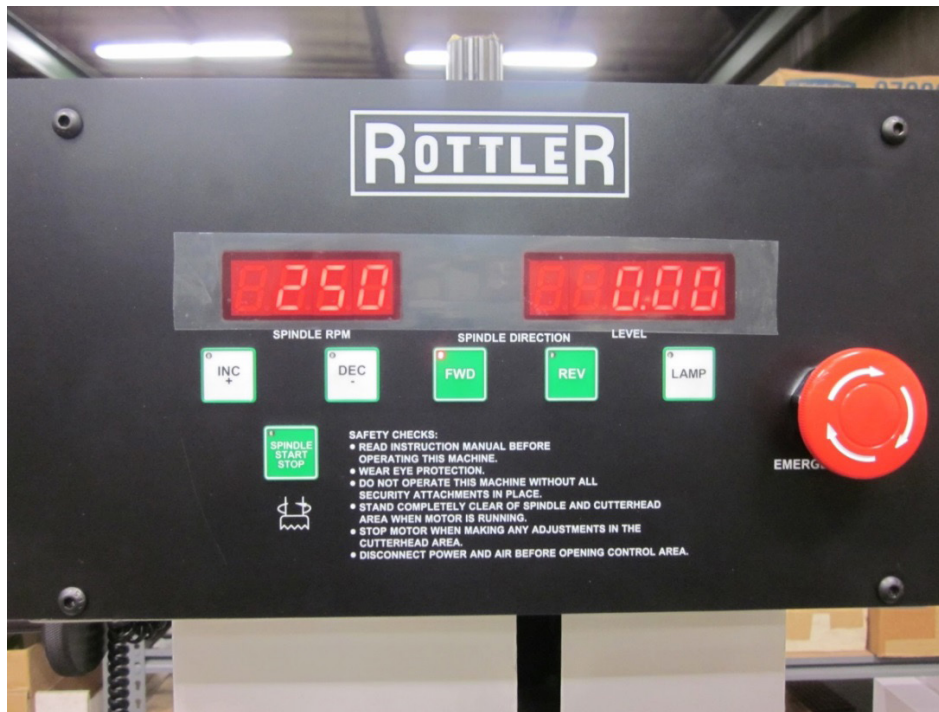

### Safety Tips Before Proceeding

- Always wear proper Safety Items (such as safety glasses and other personal safety equipment as necessary or required).
- Never wear loose fitting clothes or jewelry while working on or around Machine.
- Use proper lifting procedures when moving Cylinder Head.
- Use care when installing and/or removing Cylinder Head from Machine. Lock Head Support Assembly before loading or unloading Cylinder Head.
- Keep area around Machine free of paper, oil, water and other debris at all times.
- Keep Machine and area cleaned of excessive lubricant and lubricant spills.
- Keep Machine clear of tools and other foreign objects not needed for the operation.
- Maintain all tools clean and in their proper storage compartments to maintain them in proper working condition and to prolong tool life.
- Before machining always Inspect tooling for cracks, burrs or bent parts that might affect operation. Inspect Carbide Inserts (Seat Pocket Cutter) and Carbide Cutters (Seat Angle Cutter) to ensure they are sharp, firmly attached and are not damaged.
- NEVER force tools when operating. Tools will do a better and safer job when operated at speed rate for which they were designed.
- Always turn OFF electrical power when performing service on your machine, if service does not require power.
- High Voltage exists inside Electrical Control Enclosure – use caution when working on or around Enclosure. Machine must be disconnected from main power supply before any work can be performed inside of Enclosure.
- Machine must ONLY be operated with all Safety Guards in place and locked.



### Operation Tips Before Machining Valve Seats

- DO NOT depress Foot Pedal once centering is completed as this will change machine and cylinder Head alignment.
- Keep Spindle clean and dry. Never Used Oil.
- Clean valve guide with a brush to remove foreign matter.
- Required spindle rotation speed will vary, depending on seat hardness. As seat hardness increases, so does the spindle speed will change. Some will require full speed

**NOTE: If valve guides are so badly worn that the proper centering will be impossible, it will be necessary to replace that valve guide to achieve the a concentric valve seat.**

See suggested machining speed chart below.

**SEAT MACHINING SUGGESTED RPM CHART**

VALVE SEAT DIAMETER		SPINDLE SPEED
INCH	METRIC	RPM
15/16"	24	175
1.000"	25.4MM	150
1.125"	29MM	150
1.250"	32MM	125
1.375"	35MM	100
1.500"	38MM	100
1.625"	41MM	100
1.750"	44.5MM	100
1.875"	47.5MM	75
2.000"	51MM	75
2.125"	54MM	75
2.250"	57MM	75
2.375"	60MM	50
2.500"	63.5MM	50

### Valve Seat Machining Procedure

Seat Pocket and valve guide must be clean to ensure proper fit of the carbide pilot.

Select the correct Carbide pilot for the valve guide ID Diameter

At this point, the spindle and work head should be level according to the position of the cylinder head.

Fit the Rottler Tool Holder and pilot assembly into the spindle cone; make sure to align the locator pins before you fit it into the spindle adapter and push it until you feel that is lock.

The spindle has been engineered to allow ultra fast tooling changes.

Make sure the that spindle Self locking nut is in the off lock position; line up the two ears of the spindle adapter and insert into the spindle ISO 40 taper, the locking nut automatically will be on the lock position

To remove turn the self-locking nut to the left position, hold the spindle adapter, it may drop on the machine table. Damage will result.

## UNIPILOT Centralizing Pilots

Rottler UNIPILOT Solid Carbide Centralizing Pilots are manufactured from fine grain, sintered tungsten carbide and are ground to a very high degree of accuracy, straightness, and surface finish. They are designed for a lifetime of precision machining

### Pilot Diameter

The straight/parallel part of the pilot that fits in to the valve guide is referred to as the pilot diameter. Rottler pilots are available in 0.01mm (0.0004") increments. For best results, the clearance between the pilot and valve guide should not be more than 0.01mm (0.0004")

Most new valve guides are manufactured to a nominal size and the valve stem diameters are manufactured to be smaller than the nominal size to allow clearance for heat expansion of the valve stem when the engine is operating. For example: a 7mm valve guide has an internal diameter of exactly 7.00mm (.2756") The valve stem diameter of the intake valve is 6.98mm (.2748") and the exhaust is 6.96mm (.2740"). In order for the pilot to fit most of the valve guides, the first choice could be UCP0699 to give .01mm (0.0004") clearance. If the valve guide is used and has some wear, then the second choice of pilot could be UCP0700 (0.2756").

### Shank Diameter

The part of the pilot that fits inside the tool holder is referred to as the shank. Rottler offers three different shank sizes (6.00mm, 9.52mm, and 20.00mm). For longest tool life and best seat cutting results, the shank needs to go as far as possible inside the tool holder when cutting valve seats or boring out valve seat housings.

### Extended Length (EL) Pilots

Some cylinder heads require extended length pilots because the distance from the top of the valve guide to the head gasket surface is longer than normal. Normally this distance is about 1.0" - 1.5", it is when this distance becomes greater that extended length pilots are needed. The pilots are extended by adding material below the shank and above the tapered section of the pilot.

If you think you need an extended length pilot, please see the order form in the back of the catalog and contact Rottler for ordering assistance.



**PILOT DIAMETER SHOULD ALWAYS BE GREATER THAN VALVE STEM DIAMETER FOR BEST CONCENTRICITY**

### Modular Carbide Centralizing Pilot System for Valve Guides Over 0.875" (22.23mm)

Rottler also offers a modular carbide centralizing pilot system for very large engine applications. This system is versatile because it allows you to use different size sleeves, which are adjustable for different lengths, for different applications while using only one pilot. These sleeves are MADE TO ORDER.

Contact Rottler for more information and ordering assistance.



**FCM20EL380** Modular Carbide Centralizing Pilot for Valve Guides Over 0.875" (22.23mm). Requires a set of Interchangeable Sleeves (FCMSLXXX & FCMSUXXX) - 20mmShank Pilot

**FCMSUXXX** Modular Pilot Upper (Tapered) Sleeve - Hardened and Heat Treated - For .XXX" (XX.XXmm) Guide ID

**FCMSLXXX** Modular Pilot Lower (Straight) Sleeve - Hardened and Heat Treated - For .XXX" (XX.XXmm) Guide ID - 3.0" Overall Length

### Carbide Inserts

See Carbide Insert Catalog for a complete list of Insert Profiles available from Rottler Manufacturing.

#### Special Profiles

Special Profile Cutter Inserts can be manufactured to your exact specifications and can include a combination of angles and radius blends. See insert list and profile catalog for custom order form.

## Rottler Six and One Instructions



- 1- Checking the calibration of the six and one Setting Fixture included two tool setting fixtures, 1.250" / 31.750MM and .375" / 9.52MM and on the other end is 6.00MM. On the picture you will see master setting tool (.375" / 9.52MM) this one also will be using it to set you tool holders, for .375" (9.52mm) and 6.00MM ID tooling.,

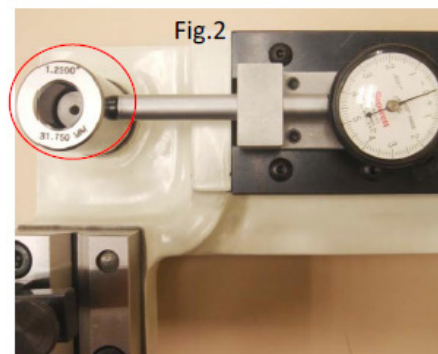
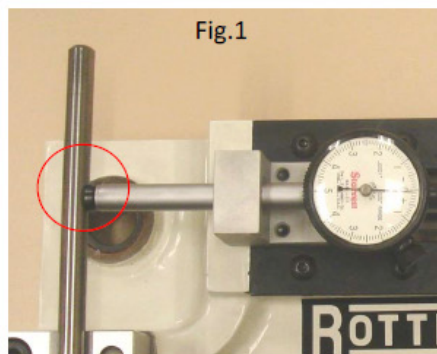

### Calibrating the Digital Micrometer

- 2- Turn the digital micrometer thimble in until the end of the micrometer is flush with the edge of the micrometer frame. Then turn the thimble out until the '0' mark on the thimble lines up exactly with the line on the barrel (see fig.1).





- a. Select mode: Press the **mm/in** button until the desired mode is shown in the digital display.  
**Note:** use a small instrument such as a pen to gently push the buttons; they are quite small and a bit delicate.
- b. Determine which calibrating setting tool you will be using to calibrate the micrometer is going to be used on. (example; calibrating pilot .375" / 952mm side)
- c. Press and hold the **SET** button, then press **+** or **-** button. "SET" will be flash in the display. This will place the micrometer in the edit mode
- d. Press and hold the **+** or **-** buttons to change the display number to the minimum set diameter Determined earlier (example; setting tool, pilot .375" / 9.52mm side).
- e. After it reach the proper reading, press the **SET** button to exit the edit mode. "SET" should no longer be shown in the display. The digital micrometer head is now set to the setting tool. (After initial setting, there is no need to press the SET button again unless display is lost at which time the micrometer must be reset)

### 3- MEASURE THE HEAD OF THE VALVE

- a. Position the Valve Stem on V Block and bring the Indicator tip to may contact with the head of the Valve until zero show on the indicator dial, the amount showing of the digital micrometer display is the actual diameter of the Head of the Valve.
- b. From that reading 2.0001"

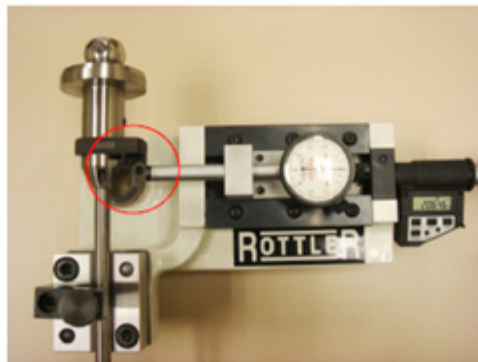
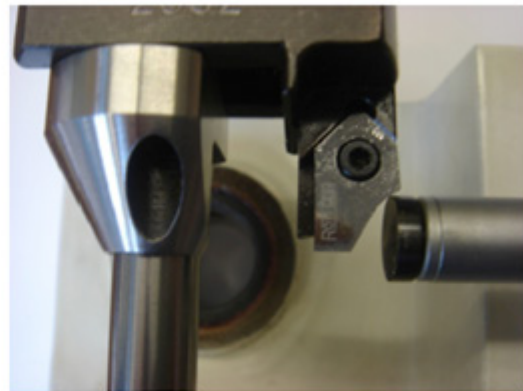
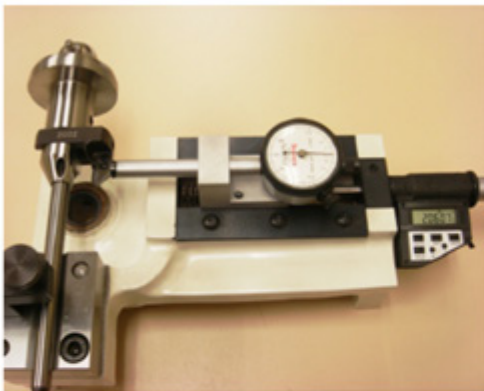
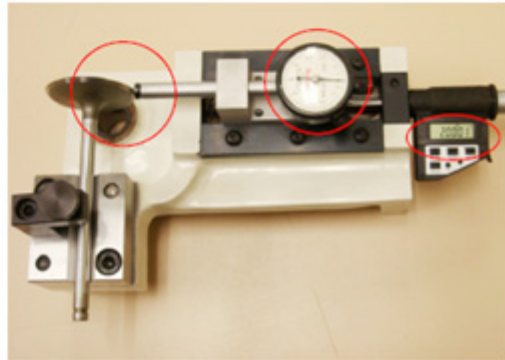

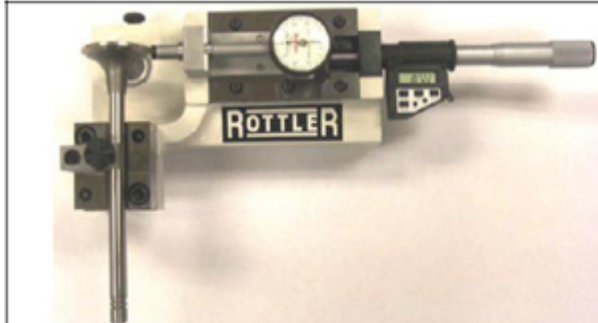

MEASURE VALVE HEAD DIA



MEASURE VALVE STEM AND PILOT DIA.

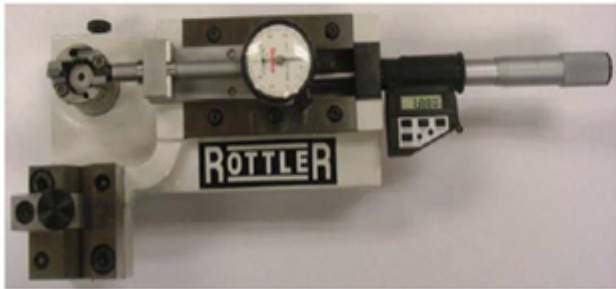

SET ADJUSTABLE DOUBLE INSERT MILLING CUTTERS



SET ADJUSTABLE DOUBLE INSERT MILLING CUTTERS



SET BORING INSERT FOR HOUSING DIA.



SET BORING INSERT FOR HOUSING DIA WITH TRIANGLE

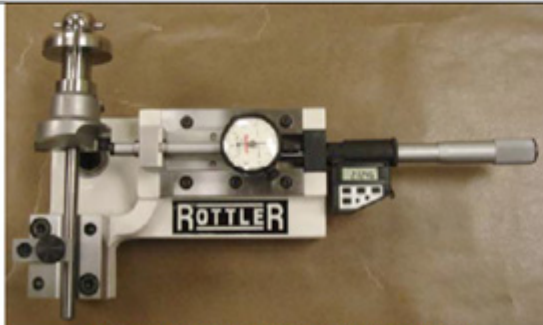

SET BORING INSERT FOR HOUSING DIA.



SET BORING INSERT FOR HOUSING DIA

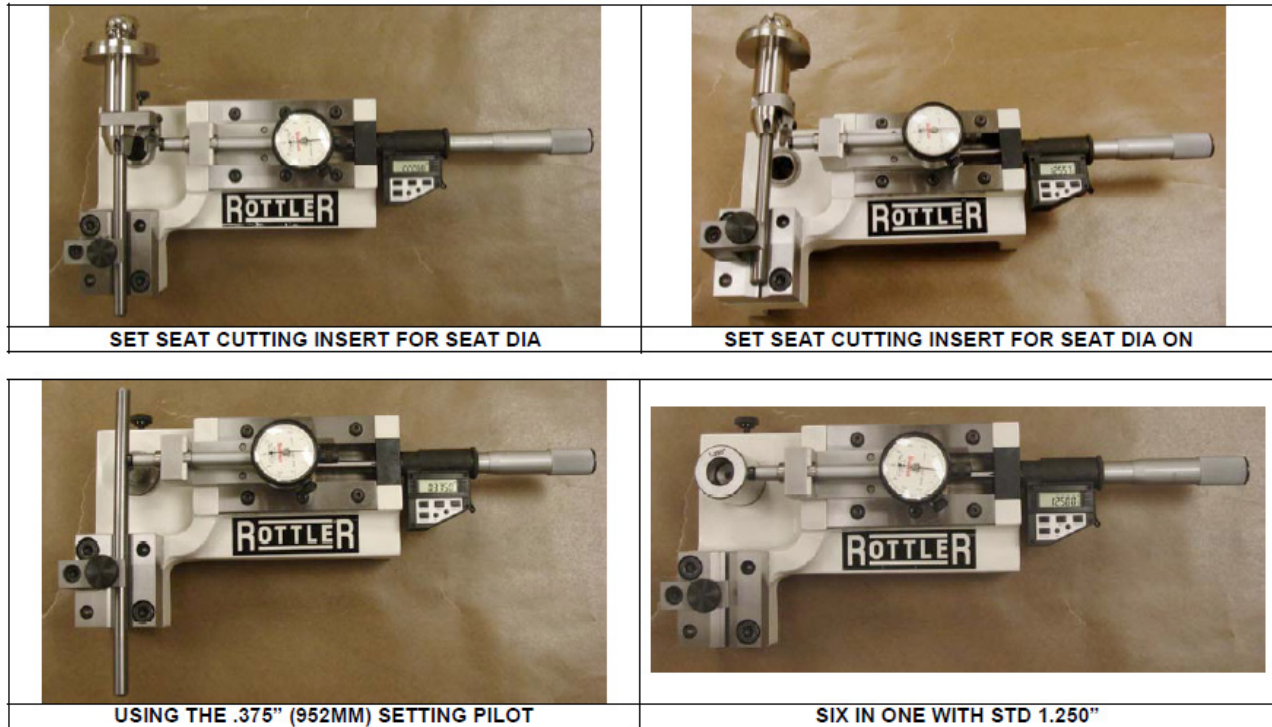

### Adjusting the Square Carbide Inserts

- The micrometer should be used.
- Set the Digital micrometer (BM) according to the valve seat insert diameter and the required interference.
- Slide the tool holder without the pilot on the micrometer.
- With the setting screw, adjust the square tip holder offset.



**IMPORTANT:** When 90 degree bits (RCA512) or the Triangle bits are fitted, check that their reference faces are perfectly clean.

The accuracy of the seat angles depends on this:

- While rotating the assembly tool holder/carbide tip holder, the carbide bit's cutting edge should just touch the micrometer spindle.
- Once in contact with the micrometer spindle, the carbide tip should not be moved at all. If this is not observed, the cutting edge may be damaged and the resulting surface quality, when machining, will be deteriorated.



### Cutting Small Diameter Valve Seats

The UPT5200 adapter has a set screw as shown in photo below – push pilot all the way into the UPT5200 and tighten set screw to hold pilot inside the UPT5200. Install the Tip Holder TH1999, adjust diameter, release set screw, and remove pilot. Be sure to use special small diameter cutting inserts such as RCA625 or RCA628 where the seat is close to the pilot side of the insert.





This page intentionally left blank

# MAINTENANCE

## Contents

<b>Maintenance.....</b>	<b>6-1</b>
<b>Quick Reference Lubrication Chart .....</b>	<b>6-1</b>
<b>Quick Reference Preventative Maintenance Chart.....</b>	<b>6-1</b>
<b>Air Adjustments .....</b>	<b>6-2</b>
<b>Float .....</b>	<b>6-2</b>
<b>Float surfaces .....</b>	<b>6-3</b>
<b>Spindle.....</b>	<b>6-3</b>
<b>Calibrating the Digital Level .....</b>	<b>6-4</b>
<b>Setting Of The Foot Pedal Operated System Actuated Valve.....</b>	<b>6-5</b>
<b>Adjusting And Aligning The Outer Spindle .....</b>	<b>6-6</b>
<b>Adjusting Outer Spindle Clearance .....</b>	<b>6-7</b>

## Maintenance

### Quick Reference Lubrication Chart

Refer to the maintenance section in the manual for lubrication location points and instruction.

Assembly	Frequency	Lube Operation	Recommended Lubricant	Date Serviced
Outer Spindle	8 Hours	Clean and Wipe with oil	ISO VG 68 Way Oil	
Brass guide shoes/slide	500 Hours	Clean and wipe with oil	ISO VG 68 Way Oil	
Grease spindle Rack and pinion	500 Hours	Clean and grease	NLGI #2 White Lithium Grease	
Grease spindle worm wheel and worm shaft	500 Hours	Clean and grease	NLGI #2 White Lithium Grease	
Grease spindle drive shaft	500 Hours	Clean and grease	NLGI #2 White Lithium Grease	
Grease rollover clamp fixture bearings	200 Hours	Clean and grease	NLGI #2 White Lithium Grease	
Grease clamp fixture Pins and Acme screw	200 Hours	Clean and grease	NLGI #2 White Lithium Grease	

### Quick Reference Preventative Maintenance Chart

Refer to the procedures in the maintenance section of the manual to make or check these adjustments. Not all of the items listed in the table below have adjustment. The information should be recorded and the amount of wear tracked so the part can be replaced before down time on the machine occurs.

Procedure	Frequency	Date Serviced/Comments
Clean top and bottom float tables	8 Hours	
Outer Spindle Bushing Adjustment	500 Hours	
Brass Shoe Adjustment	500 Hours	
Angle sensor calibration	500 Hours	
Spindle Drive Belt Adjustment	1000 Hours	
Adjust workhead clamp plate bearings	1000 Hours	
Machine Level Adjustment	1000 Hours	

**CAUTION** All floating surfaces should be dry and clean do not oil the surfaces, oil will cause the work head not to float properly.

### Air Adjustments



### Float

The float regulators are located on the left side of machine base. Marked "Work Head Air Float Adjustment" If the work head is not floating properly it could be from too much or too little air from the regulator. Starting with all regulators set at 1 bar with "workhead float" button activated, slowly turn all up .5 bar at a time until workhead start to float. Pushing work head front to rear checking for stiff spots. If workhead is dragging in the forward position, (workhead pulled closest to operator) raise the 2 front regulators 1 mark until it floats without dragging. Same for rear. You may have to go back and forth a few times to get this correct. If workhead is not dragging lower the PSI until it does and then raise 1 notch at a time until it is free. Typically the front two regulators will be slightly higher than the rear two. Once the correct float is established lock the regulators in place by pushing in on the blue adjusting knob

**CAUTION** Use as little air as possible to achieve correct floatation. Using too much air will could cause the spindle base to vibrate and not center properly on the on the pilot.



**Float surfaces****CAUTION**

Wipe clean daily All floating surfaces should be dry and clean do not oil the surfaces, oil will cause the work heat not to float properly.

**Spindle**

Wipe clean and oil 5 drops daily. To oil, lift lever at top of oiler. To adjust, rotate lever knob.

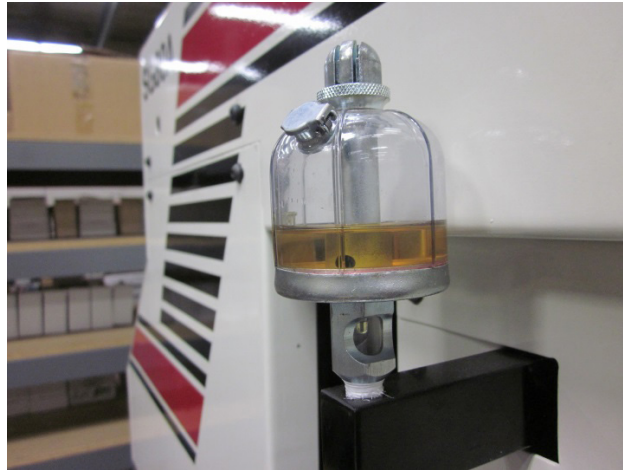

### Calibrating the Digital Level

**NOTE:** *Even though the level has been carefully calibrated at the factory, it is a good idea to recheck calibration before putting the machine into service. In the event that the level is dropped or handled roughly then the following recalibration methods should be implemented.*

The level assembly is referenced to the spindle via the level pin. It is important to check alignment of pin in reference to the spindle. This is accomplished by mounting a magnetic base dial indicator to the machine spindle and sweeping the pin vertically by raising or lowering spindle to check alignment. Pin alignment should be checked in two positions at 90 degrees to each other. If the pin alignment needs correcting, do so with the set screws located at base of pin block.

Install level on pin. Orient level to read left to right. Tilt head left or right until level reads 0.00. Now rotate level 180 degrees. The reading should be 0.00, if not then it will be necessary to calibrate the inclinometer to the level body. This is accomplished by loosening the clinometer's two retaining screws and pivoting the inclinometer until it repeats when level is rotated 180 degrees.



Example: level reads 0.04 to the left, when rotated 180 degrees to the right it should read minus 0.04.

Check the level reading with the pickup oriented front to back. It should read 0.00 if the machine has been properly leveled with a machinist level.

If the readout does not read 0.00 then chances are the machine's leveling procedures have not been properly followed or there are internal problems with the levels electronics.

The sensitivity of the level is so great that it may not zero totally, even while the machine is not being touched. The alignment tolerance for installing guides is plus or minus .05 degrees, and for forming three angle seats is plus or minus .1 degrees.

### Setting Of The Foot Pedal Operated System Actuated Valve

When the food pedal is not pressed, the clearance between the left valve plunger (when looking from the front of the machine) and the food pedal bracket should be 0.010" (0.20mm) whereas the clearance between the right valve plunger and the food pedal bracket should be 0.039" (0.75mm).

This can be achieved by loosening the two fixing screws and adjusting the valve mounting bracket. Tighten back the bracket (see fig below).

When the food pedal is pressed, remove the black air tube from the left port and it should be a full air flow, whereas when you remove the green air tube from the right port it should not be any air coming out.

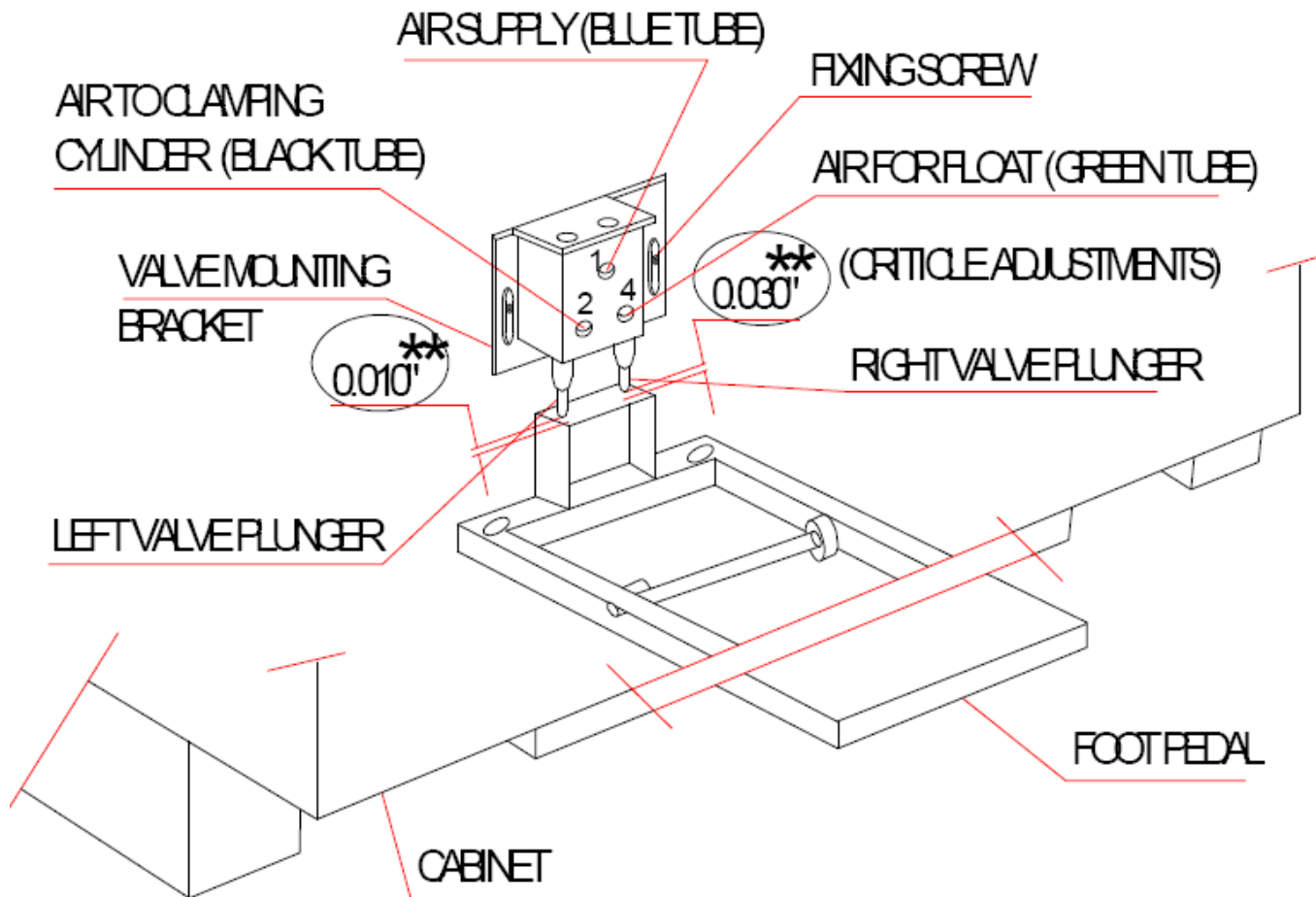

## Adjusting And Aligning The Outer Spindle

There are 2 brass guide shoes located on the guide plate on top of the spindle that align the rack gear on the back of the spindle with the pinion gear that moves the spindle up and down.

Lower the spindle to the center position of travel.

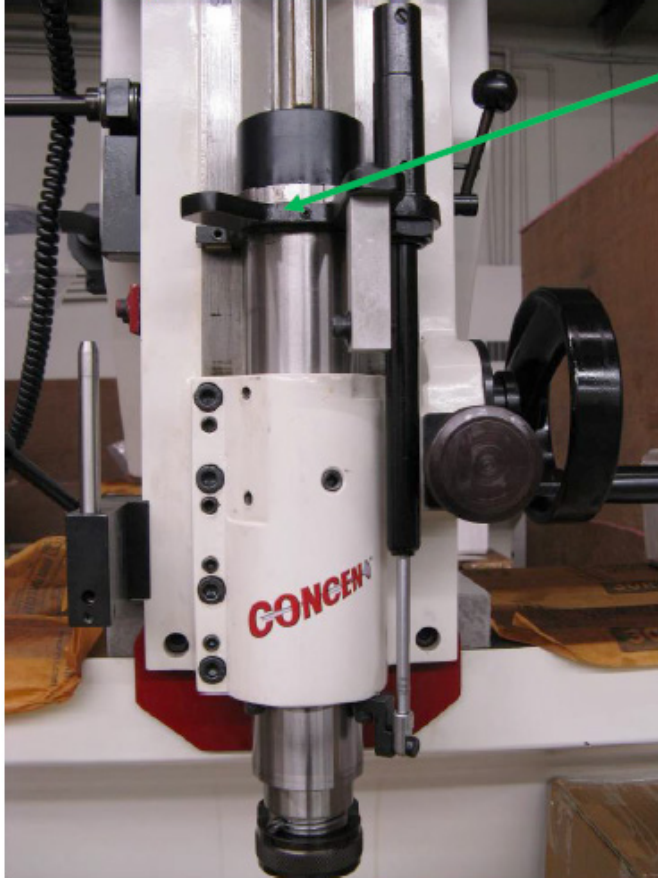

Check the guide plate at the top of the spindle, tighten if necessary.

Clean and lightly lubricate sliding guide surfaces with grease. Adjust brass guide shoes on guide plate so that there is no twisting movement. Run the spindle through its full travel to confirm that there is no binding.

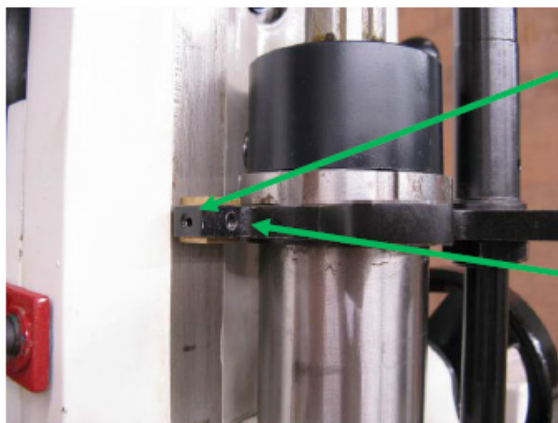

Loosen locking screw to adjust brass guide shoe. Tighten after adjusting.

Use adjusting screw to adjust brass guide shoe.



## Adjusting Outer Spindle Clearance



Loosen the 4 lock bolts.



Loosen the 4 adjusting set screws.

Clean outer spindle and lubricate – add a few drops of oil to a clean cloth and wipe outer spindle.

Starting with the bottom set of lock bolt and adjusting set screws, tighten the lock bolt until there is drag on the spindle when it is move through its range of travel.

Then tighten the adjusting set screw until the amount of drag on the spindle is reduced to the point that there is a slight drag on the spindle through its range of travel.

You may have to make further adjustment to the lock bolt and set screw the get the spindle adjusted properly.

Repeat the above procedur the other 3 sets of lock bolts and set screws.

# **TROUBLESHOOTING**

## **Contents**

**Troubleshooting .....7-1**

**Eccentricity Problems when Cutting Three Angle Seats..... 7-1**

**SG Fault and Error Codes..... 7-3**

## Troubleshooting

### Eccentricity Problems when Cutting Three Angle Seats

- Spindle floated to improper center location.
- Excessive pressure when forming seat.
- Incorrect spindle speed.
- Worn or improperly selected pilot.
- Worn Valve Guide.

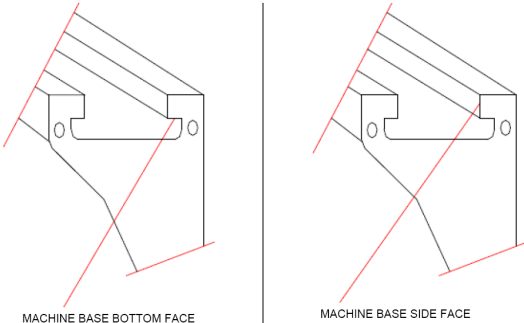
<p>Workhead base does not float</p> <p>Concentricity is not within the tolerance</p>	<p>1- Insufficient air pressure</p> <p>2- Clamping plate does not drop when unclamped due to less clearance between upper floating base and ball bearings mounted on clamping plate</p> <p>3- Clamping plate does not drop when unclamped due to the improper adjustment of the four clamping bolts.</p>	<p>1- Set air pressure of supplied line should be minimum <b>90</b> PSI ( 6 Bars)</p> <p>2- Adjust 4 corner air adjustment higher</p> <p>2- Take the workhead to one end of the of the upper floating surfaces (Left or Right side) float the workhead and pull it against the front on the T Slatted guide surfaces, then loose the set screws of the eccentric pin to increase clearance by using a feeler gage of 0.008" to 0.010" (0.20mm to 0.25mm) in between the T slotted guide surfaces of the upper base and the eccentric ball bearing; (see fig.1-4)</p> <div style="text-align: center;">  </div> <p>Lock the setscrews, remove the feeler gage and inspect if is with the tolerance across the all surfaces. Repeat on opposite end,</p> <p>3- Adjust nylock nuts to set he correct clearance between the bottom side face of the locking T-Slot of the floating base (Riser) and the top part of the clamping plate. They are 2 clamping bolts one each side. The dropping clearance when it is in the floating mode should be 0.015" (0.38mm)on all the four corners of the workhead clamping plate (see fig. 5-6)</p>
--	--	---

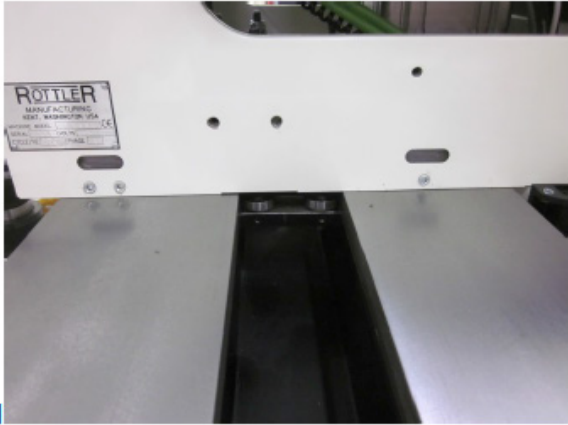

Fig1

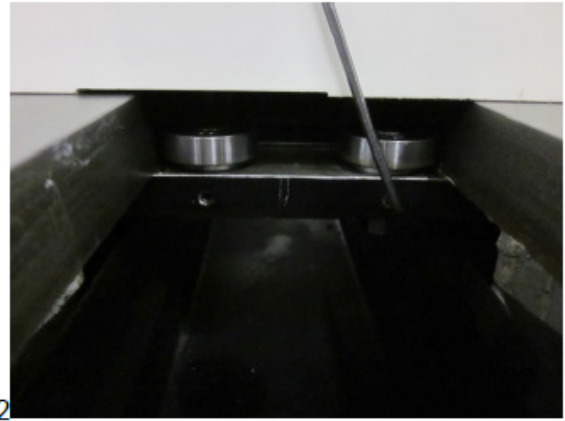

Fig2

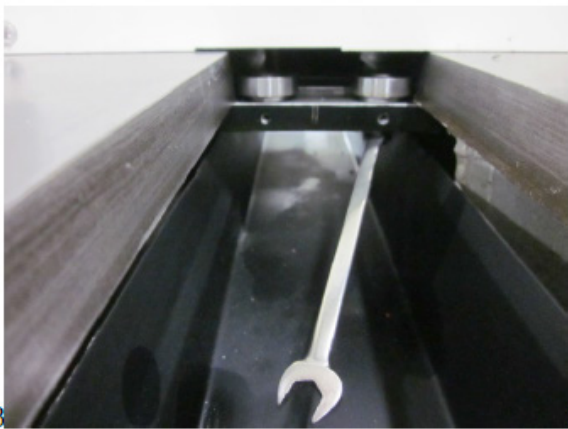

Fig3



Fig4

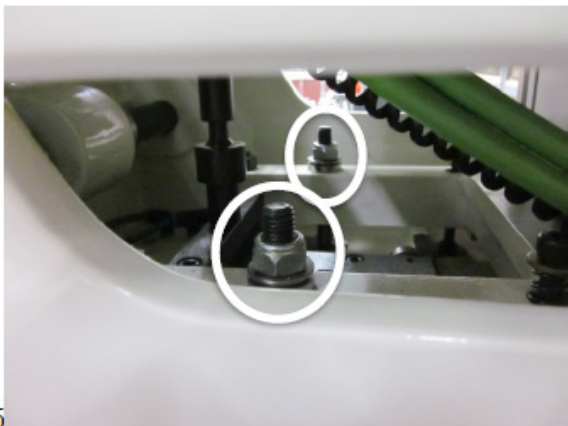

Fig5



Fig6

## SG Fault and Error Codes

Errors are sensed by the SG controller. The left display shows Err.

Faults are sensed by the motor driver. The left display shows FLt.

Alarms are sensed by the motor driver. The left display shows ALr.

To clear an error requires the condition be resolved (correct wiring...) and cycle the e-stop.

To clear fault requires the condition be resolved (correct wiring...), press the reset key on the drive front panel, and cycle the e-stop. If e-stop is cycled long enough the drive will power down and that will clear the fault too.

Alarms clear as the condition that caused them disappears (the over torque is relieved...).

<b>Error Display</b>	<b>Description</b>
C bUS	Communications lost with drive
<b>Fault Display</b>	<b>Description</b>
Uv1	Undervoltage
Uv2	Control Power Supply Undervoltage
Uv3	Soft Charge Circuit Fault
GF	Ground Fault
oC	Overcurrent
ov	Overvoltage
oH	Heatsink Overheat
oH1	Heatsink Overheat
oH3	Motor Overheat (PTC input)
oH4	Motor Overheat (PTC input)
rH	Braking Resistor Overheat
oL1	Motor Overload
oL2	Drive Overload
oL3	Overtorque Detection 1
oL4	Overtorque Detection 2
oL7	High Slip Braking Overload
rr	Dynamic Braking Transistor
EF1	External Fault 1, input terminal S1
EF2	External Fault 2, input terminal S2
EF3	External Fault at input terminal S3
EF4	External Fault at input terminal S4
EF5	External Fault at input terminal S5
EF6	External Fault at input terminal S6
EF7	External Fault at input terminal S7



oS	Overspeed
dEv	Excessive Speed Deviation
PGo	PG Disconnect
PF	Input Phase Loss
LF	Output Phase Loss
oPr	Digital Operator Connection
Err	EEPROM Write Error
CE	MEMOBUS/Modbus Communication Error
bUS	Option Communication Error
CF	Control fault
EF0	PROFIBUS-DP Option External Fault
FbL	PID Feedback Loss
UL3	Undertorque Detection 1
UL4	Undertorque Detection 2
oF1	Hardware Fault
LF2	Output Current Imbalance
Sto	Pullout Detection
PGo	PG Disconnected
SEr	Too many speed search restarts
FbH	PID Feedback Loss
oL5	Mechanical Weakening Detection 1
UL5	Mechanical Weakening Detection 2
CoF	Current Offset Fault
dWFL	DriveWorksEZ Fault
CPF02	A/D Conversion Error
CPF03	PWM Data Fault
CPF06	Drive specification mismatch during Terminal Board or Control Board replacement
CPF07	Terminal Board Communication Fault
CPF08	EEPROM Serial Communication Fault
CPF11	RAM fault
CPF12	Flash memory circuit exception
CPF13	Watchdog circuit exception
CPF14	Control Circuit Fault
CPF16	Clock Fault
CPF17	Timing Fault
CPF18	Control Circuit Fault
CPF19	Control Circuit Fault
CPF20	Hardware fault at power up
CPF21	Hardware fault at communication start up

CPF22	A/D Conversion Fault
CPF23	PWM Feedback Fault
CPF24	Drive capacity signal fault
oFA00	Option compatibility error
oFA01	Option not properly connected
oFA03	Option Self-diagnostics Error
oFA04	Option Flash Write Mode Error
<b>Alarm Display</b>	<b>Description</b>
Uv	Undervoltage
ov	Overvoltage
oH	Heatsink Overheat
oH2	Drive Overheat
oH3	Motor Overheat
oL3	Overtorque 1
oL4	Overtorque 2
EF	Run commands input error
bb	Drive Baseblock
EF1	External Fault 1, input terminal S1
EF2	External Fault 2, input terminal S2
EF3	External Fault 3, input terminal S3
EF4	External Fault 4, input terminal S4
EF5	External Fault 5, input terminal S5
EF6	External Fault 6, input terminal S6
EF7	External Fault 7, input terminal S7
FAN	Cooling Fan Error
oS	Overspeed
dEv	Excessive Speed Deviation
PGo	PG Disconnected
oPr	Digital operator connection fault
CE	Modbus Communication Error
bUS	Option Communication Error
CALL	Serial Communication Transmission Error
oL1	Motor Overload
oL2	Drive Overload
EF0	Option Card External Fault
rUn	Motor Switch command input during run
UL3	Undertorque Detection 1
UL4	Undertorque Detection 2
SE	MEMOBUS/Modbus Test Mode Fault

FbL	PID Feedback Loss
FbH	PID Feedback Loss
dnE	Drive Disabled
PGo	PG Disconnected
HCA	High Current Alarm
HbbF	Safe Disable Input
Hbb	Safe Disable Input
oL5	Mechanical Weakening Detection 1
UL5	Mechanical Weakening Detection 2
dWAL	DriveWorksEZ Alarm
<b>RT4 Error Codes</b>	<b>Description</b>
1	failed communication to display boardd
2	no motor voltage (blown fuse)
3	no motor current (lost motor conn)
4	over current >6.8 amps (short)
5	over current, >4.5 amp for 2 sec (slow)
6	over current >10 amp for 1/100 sec (fast)

This page intentionally left blank

# MACHINE PARTS

## Contents

<b>Consumable Parts .....</b>	<b>8-1</b>
<b>Carbide Inserts .....</b>	<b>8-2</b>
Special Profiles .....	8-2
<b>Carbide Pilots .....</b>	<b>8-3</b>
<b>Machine Parts .....</b>	<b>8-4</b>
Base, Table and Riser Assembly Old Design.....	8-4
Base Assembly Old Design .....	8-7
Spindle Assembly Old Design.....	8-10
Transmission Assembly Old Design.....	8-14
Head Support Assembly Old Design .....	8-17
SG80M Pneumatic Drawing Old Design .....	8-21
Bed, Table, and Riser Assembly New Design .....	8-22
Base Assembly New Design.....	8-25
Spindle Housing Assembly New Design .....	8-28
Transmission Assembly New Design .....	8-32
Head Support and Cradle Assembly New Design .....	8-35
Pneumatic Circuit Diagram New Design .....	8-39
SG80M Electrical Drawing .....	8-40



## Consumable Parts

REFERENCE	DESCRIPTION
SLEEVE R1	Spindle adapter replacement sleeve
BSW002	Diamond Wheel Cutting Bit Sharpener replacement Wheel (3.000" Diameter OD by .375" ID)
PRW600PIN	Replaceable Pins for PRW600 Pilot Removable wrench tool
PRW375PIN	Replaceable Pins for PRW375 Pilot Removable wrench tool
PRW20PIN	Replaceable Pins for PRW375 Pilot Removable wrench tool
VT-FP1562	Replacement Foam Pad for Round Vacuum Pad 1.562" diameter
VT-FP1875	Replacement Foam Pad for Round Vacuum Pad 1.875" diameter
VT-FP2125	Replacement Foam Pad for Round Vacuum Pad 2.125" diameter
VT-FP3125	Replacement Foam Pad for Round Vacuum Pad 3.125" diameter
VT-FP25X22	Replacement Foam Pad for Square Vacuum Pad 2.500" x 2.250" square
VT-FP31X20	Replacement Foam Pad for Square Vacuum Pad 3.125" x 2.000" square
VT-FP33X27	Replacement Foam Pad for Square Vacuum Pad 3.375"x 2.750" square
511-29-12F	T7 Torx driver for 1/4" insert (straight angle insert holders only)
511-29-12E	TORX SCREW M2.5 X 0.45 X (straight angle insert holders only)
T8S	T8 Torx Tip Holding Screws
T15S	T15 Torx Tip Holding Screws
MHS-375	Fixed Double Replaceable Insert Milling Head Screws for Large diameter milling Head (3/8" insert)
MHS-250	Fixed Double Replaceable Insert Milling Head Screws for Small diameter milling Head (1/4" insert)
S1032-250	BH375R1 and BH600R1 Tip Holder Looking Screw (10/32" X 1/4") <b>Req. 2</b>
S250-28-250	BH375WR1 Tip Holder Looking Screw 1/4"-28" X 1/4" <b>Req. 2</b>
S1032-437	TH1999 Adjusting Screw (10/32" X 7/16")
S1032-375	TH2000 Adjusting Screw (10/32" X 3/8")
S1032-500	TH2001 Adjusting Screw (10/32" X 1/2")
S1032-625	TH2002 Adjusting Screw (10/32" X 5/8")
S600-1570	TH2003 Adjusting Screw (6.00mm X 15.70mm)
S600-2015	TH2004 Adjusting Screw (6.00mm X 20.15mm)
M10X15X35	SG7 Rollover Fixture Hold down swivel Handle Zinc Handle 35mm (1.375") Long stud (KHF-725)
500-13X2	SG8 Rollover Fixture Hold down swivel Handle Zinc Handle 2.000" Long stud (KHF-162)
500-13X1375	SG7- SG8 Rollover Fixture Lock swivel Handle Zinc Handle 1.375" Long stud (KHF-158)
ICC003	Insert, Indexable carbide, for Fixed milling heads - large size - for 1.562" and larger cutters
ICC002	Insert, Indexable, carbide, for Fixed milling heads - small size - for 1.250" to 1.500" cutters

## Carbide Inserts

See Carbide Insert Catalog for a complete list of Insert Profiles available from Rottler Manufacturing.

## Special Profiles

Special Profile Cutter Inserts can be manufactured to your exact specifications and can include a combination of angles and radius blends.

There is three different style insert blanks.

A - Style Blank insert, RCA is a small insert for all standard applications.

B - Style Blank insert, RCB in design for long profiles like High Performances profiles with multi angles o Radius or other special applications

C - Style Blank insert, RCC is a much thicker insert for Heavy Duty tooling and can be use for hard seat materials (will work only on the Large Inserts holders series 3000 style insert holders, for the 20.00mm tooling)

Special Order - Special Profile Carbide Cutter Bits are generally considered to be "Customer Proprietary". These are uniquely numbered, exclusively for the ordering customer; prices will vary depending on quantities and additional charge for initial run.

Call us for a quote.

RT312 Insert, triangular positive rake, 3/8 1/32" (.787mm) radius, for the TH3000 series insert holder and  
RT212 Insert, triangular positive rake, 1/4" (6.35mm) 1/32 " radius for the TH2000 series, for hard seat materials applications (Counterboring and straight angles only )

## Carbide Pilots

See Carbide Pilot catalog for a complete list of Pilots available.

Rottler Solid Fixed Carbide Pilots are manufactured from fine grain sintered tungsten carbide and are ground to a very high degree of accuracy, straightness and surface finish - designed for a life time of precision machining!

The part number of the pilot represents the actual diameter in metric of the straight/parallel part of the pilot where the pilot fits into the valve guide.

For example:

UCP0700 means that the diameter of the part of the pilot that goes into the valve guide is 7.00mm (0.2756")

UCP1270 means that the diameter of the part of the pilot that goes into the valve guide is 12.70mm (0.5000")

Pilots are available in increments of .01mm (0.0004"). Normally, a small amount of clearance approx .01mm (0.0004") is required between the pilot and the valve guide.

Most new valve guides are manufactured to a nominal size and the valve stem diameters are manufactured to be smaller than the nominal size to allow clearance for heat expansion of the valve stem when the engine is operating. For example: a 7mm valve guide has an internal diameter of exactly 7.00mm (.2756") The valve stem diameter of the intake valve is 6.98mm (.2748") and the exhaust is 6.96mm (.2740"). In order for the pilot to fit most all valve guides, the first choice could be UCP0699 to give .01mm (0.0004") clearance. If the valve guide is used and has some wear, then the second choice of pilot could be UCP0700(0.2756").

Rottler makes 3 sizes of shanks of pilots:

6.00mm (0.2362") for small valves guides 6mm (0.236") and below. The part number for these pilots is UCPM.

0.375" (9.52mm) for common size valve guides, 6-14mm (.236-.625"). The part number for these pilots is UCP.

20mm (0.7874mm) for large valve guides for SG80A machine. These pilots are made to order specifications.

### Machine Parts

### Base, Table and Riser Assembly Old Design

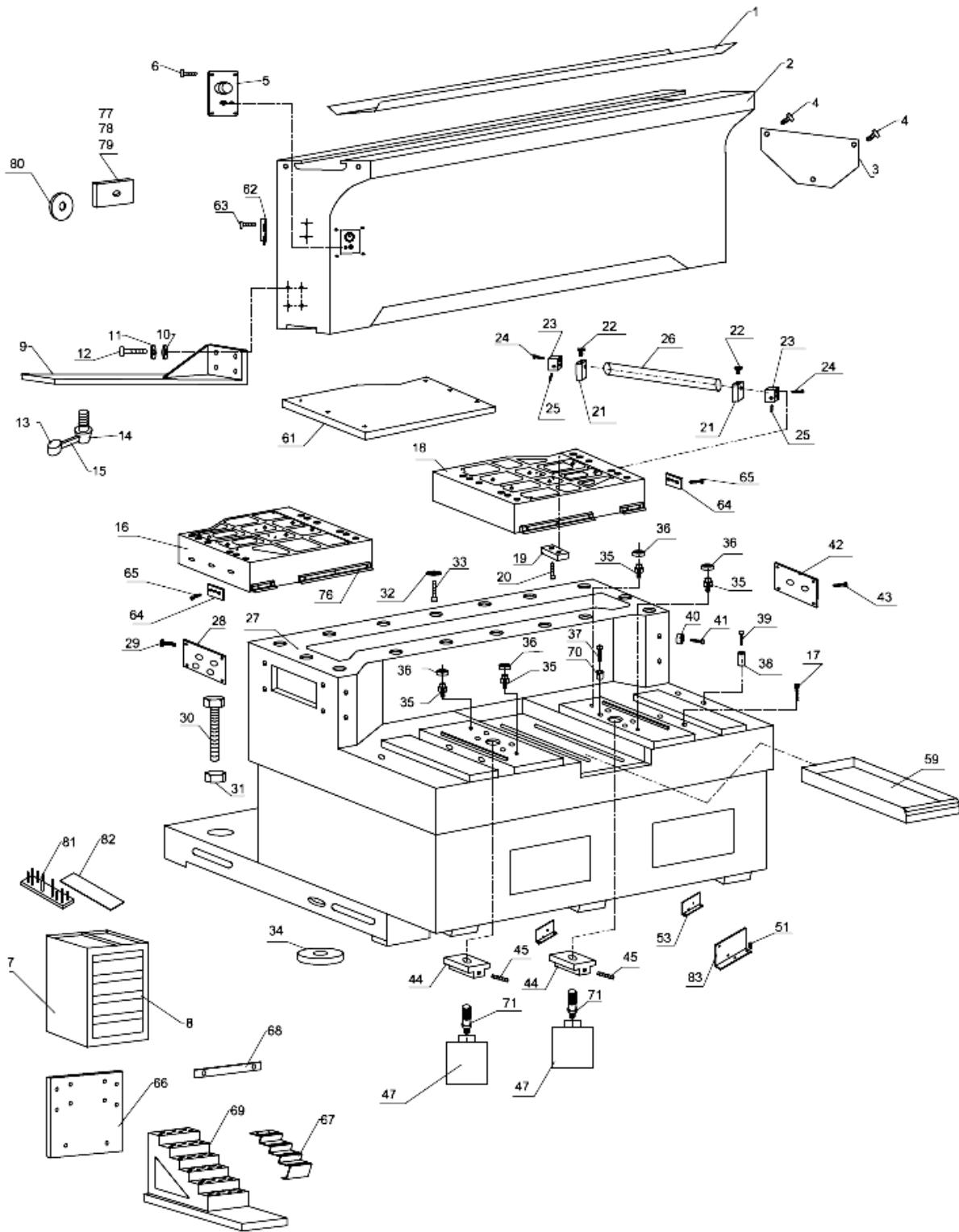

NO.	PART NO.	DESCRIPTION	SG-80M
1	055A-550	PAN COVER	1
2	055A-500	RISER	1
3	055A-719	END COVER	2
4		ALLEN BUTTON HEAD SCREW M6X12	4
5	055A-546	NAME PLATE	1
6		ALLEN BUTTON HEAD SCREW M6X12	4
7	055A-760	TOOL CABINET	1
8		TOOL TRAY	4
9	430-806	MOUNTING BRACKET	1
10		PLAIN WASHER M8	5
11		LOCK WASHER M8	5
12		HEX. SCREW M8 X 30	4
13	430-802	BALL (M8x25MM O.D.)	1
14	430-817	CLAMP PIN	1
15	430-823	CLAMP LEVER	1
16	055A-608	LEFT CROSS TABLE	1
17		ALLEN SCREW M10X20	2
18	055A-607	RIGHT CROSS TABLE	1
19	055A-612	STOPPER	2
20		ALLEN SCREW M6X20	4
21	055A-528	STOP DOG	2
22	055A-551	THUMB SCREW	2
23	055A-529	SUPPORT	2
24		ALLEN SCREW M6X30	2
25		ALLEN GRUB SCREW M5X8	2
26	055A-615	STOPPER ROD	1
27	055A-611	CABINET	1
28	055A-617	NAME PLATE	1
29		ALLEN BUTTON HEAD SCREW M6X12	4
30	430-818	HEX HEAD SCREW M16X70	5
	430-818A	HEX HEAD SCREW M16X180	1
31		HEX NUT M16	6
32		MACHINED WASHER M12	16
33		ALLEN SCREW M12X35	16
34	430-819	PAD	6
35	055A-516	BEARING PIN	4
36		BALL BEARING	4
37		ALLEN SCREW M10X55	8
38	055A-613	STOPPER	1
39		ALLEN SCREW M8X35	1
40	055A-602	NYLON STOPPER	2
41		ALLEN SCREW M8X16	2
42	055A-708	NAME PLATE	1
43		ALLEN BUTTON HEAD SCREW M6X12	4
44	055A-515	T-NUT	2
45		ALLEN GRUB SCREW M5X8	2
46	-----	-----	-----
47		PNEUMATIC CYLINDER	2
48	-----	-----	-----
49	-----	-----	-----
50	055A-652	BULKHEAD BRACKET	2
51		ALLEN HEAD SCREW M6X12	4
52		ALLEN HEAD SCREW M8X16	2
53	055A-762	BRACKET	-----



S. NO.	PART NO.	DESCRIPTION	
			<b>SG-80M</b>
54		FOOT SWITCH	2
55	055A-650	FOOT SWITCH HOUSING	1
56	-----	-----	-----
57	-----	-----	-----
58	-----	-----	-----
59	055A-709-3	CHIPS TRAY	1
60	-----	-----	-----
61	055A-709-7	CROSS TABLE COVER	2
62	033-069	BRACKET	1
63		ALLEN SCREW M6X12	2
64	055A-664	PLATE	2
65		ALLEN CSK HEAD SCREW M6 X 12	4
66	055A-757	SUPPORT PLATE	1
67	055A-756	STAND	1
68	430-839-4	NAME PLATE	1
69	055A-758	PILOT STAND	1
70	055A-641	CYL. SPACER	8
71	055A-642	CYL. STUD	2
72.	-----	-----	-----
73.	-----	-----	-----
74.	-----	-----	-----
75.	055A-712	CONTROL BOX SPACER	2
76.	055A-697	WIPERS	1 SET
77	101A-109	VACUUM PAD	1
78	101A-110	VACUUM PAD	1
79	101A-111	VACUUM PAD	1
80	101A-112	VACUUM PAD	1
81	055A-759	TOOL BOARD (L.H.) WITH PINS	1
82	055A-755	RUBBER SHEET	1
83	055A-770	BRACKET	----

### Base Assembly Old Design

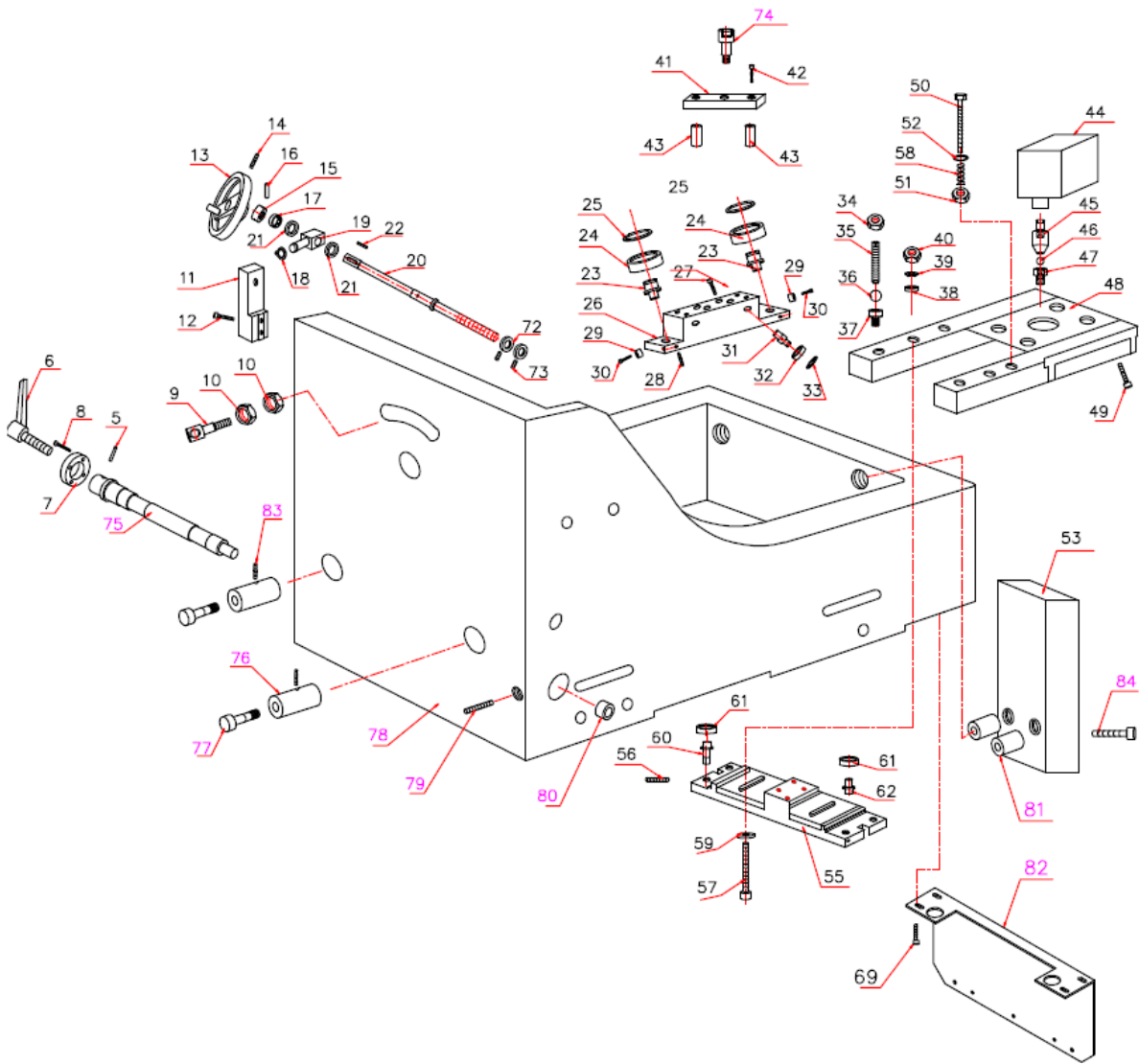

S. NO.	PART NO.	DESCRIPTION	QTY
1	055A-300	BASE	---
2	055A-317	ECCENTRIC COLLER	---
3	055A-326	TAPER PIN	---
4	055A-332	CLAMPING ROD	---
5		CYLINDRICAL PIN DIA. 1/8"X1-1/8" LONG	---
6		ADJUSTABLE HANDLE	1
7	055A-321	SPACER HOUSING	1
8		ALLEN SCREW M6X16	4
9	055A-264	LOCATING BOLT	1
10	055A-320	NUT	2
11	055A-327	SCREW BLOCK	1
12		ALLEN SCREW M8X35	2
13	055A-311	HAND WHEEL WITH HANDLE	1
14		ALLEN GRUB SCREW M6X10	1
15	055A-309	SPACER	1
16		SPRING DOWEL DIA. 1/8"X1-1/8" LONG	1
17		NEEDLE ROLLER BEARING	1
18		EXT. CIRCLIP A16	1
19	055A-304	GUIDE PIN	1
20	055A-310	INCNCILATION ROD	1
21		NEEDLE THRUST BEARING	2
22		PARALLEL KEY 3/16"X3/16"X7/8"	1
23	055A-502	BEARING PIN	2
24		BALL BEARING	2
25		EXT. CIRCLIP A25	2
26	055A-344	CROSS BEARING SUPPORT	1
27		ALLEN SCREW M6X55	4
28		ALLEN GRUB SCREW M5X8	6
29	055A-305	STOPPER	2
30		ALLEN SCREW M5X12	2
31	055A-501	BEARING PIN	4
32		BALL BEARING	4
33		EXT. CIRCLIP A10	4
34		HEX NUT M12	2
35	055A-308	SET SCREW	2
36		STEEL BALL DIA 1/4"	2
37	055A-301	PIVOT	2
38	055A-324	SPHERICAL WASHER	6
39	055A-323	SPHERICAL WASHER	6
40		NYLOCK HEX NUT M12	2
41	055A-316	SWIVEL BRACKET	1
42		ALLEN SCREW M6X55	2
43	055A-315	SPACER	2
44		PNEUMATIC CYLINDER	1
45	055A-306	PIVOT PIN	1
46		STEEL BALL DIA 3/8"	1
47	055A-303	BALL SUPPORT	1
48	055A-322	CLAMPING BRACKET	1
49		ALLEN SCREW M12X30	4
50		HEX HEAD SCREW M8X100	2
51		HEX NUT M8	2
52		WASHER M8	2
53	055A-627	WEIGHT	1
54		ALLEN SCREW M12X75	---

S. NO.	PART NO.	DESCRIPTION	QTY
55	055A-343	CLAMPING PLATE	1
56		ALLEN GRUB SCREW M5X8	4
57		HEX HEAD SCREW M12X180	2
58	282580	COMP. SPRING	2
59	055A-325	SPACER	2
60	055A-312	BEARING PIN	2
61		BALL BEARING	4
62	055A-313	BEARING PIN	2
63	055A-217	CLAMPING PLATE	---
64	055A-352	ALLEN HEAD SCREW	---
65		HEX NUT M10	---
66	055A-224	PIN	---
67	055A-302	TIE ROD SUPPORT	---
68	055A-710	CABLE TRAY WITH COVER	1
69		ALLEN SCREW M6X12	4
70	-----	-----	---
71	-----	-----	---
72	055A-342	STOP COLLAR	2
73		ALLEN SET SCREW M6X12	2
74	<b>055A-341</b>	<b>TIE ROD SUPPORT (M)</b>	<b>1</b>
75	<b>055A-334</b>	<b>ECCENTRIC SHAFT (M)</b>	<b>1</b>
76	<b>055A-336</b>	<b>CLAMPING BLOCK (M)</b>	<b>2</b>
77	<b>055A-339</b>	<b>CLAMPING BOLT (M)</b>	<b>2</b>
78	<b>055A-333</b>	<b>BASE (M)</b>	<b>1</b>
79		ALLEN HEAD SET SCREW	2
80	<b>055A-345</b>	<b>ECCENTRIC BUSH (M)</b>	<b>1</b>
81	<b>055A-629</b>	<b>WEIGHT SPACER(M)</b>	<b>2</b>
82	<b>055A-346</b>	<b>CONDUIT PLATE (M)</b>	<b>1</b>
83		ALLEN HEAD GRUB SCREW M6x15	2
84		ALLEN HEAD CAP SCREW M12x115	2

### Spindle Assembly Old Design

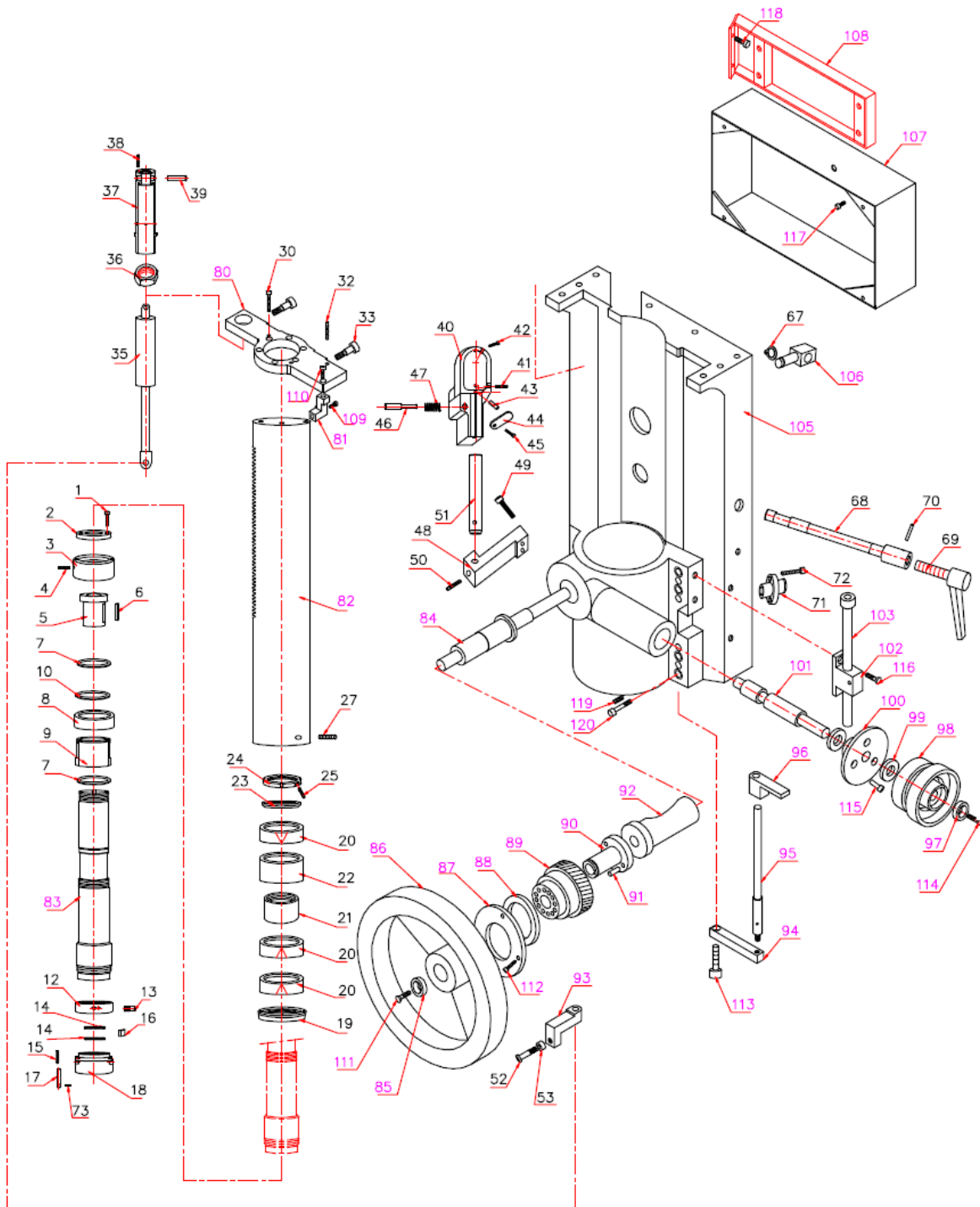



S. NO.	PART NO.	DESCRIPTION	QTY
1		ALLEN SCREW M5X12	2
2	055A-103	NYLON STOPPER	1
3	055A-105	NUT	1
4		ALLEN GRUB SCREW M5X8	1
5	055A-404	SPLINE BUSH	1
6		PARALLEL KEY 1/4"X1/4"X1-1/2"	1
7		EXT. CIRCLIP A48	2
8		NEEDLE ROLLER BEARING	1
9	055A-122	BEARING SUPPORT	1
10		EXT. CIRCLIP A55	1
11	055A-117	SPINDLE	---
12	KS-09-06	COVER	1
13	KS-08-01	STOP PIN	1
14	KS-09-03	COMP. SPRING	2
15	KS-08-04	COMP. SPRING	1
16	KS-08-02	PAD	1
17	KS-08-05	PIN	1
18	KS-09-07	NUT	1
19	055A-102	QUILL NUT	1
20		ANGULAR CONTACT BALL BEARING	3
21	055A-124	SPACER	1
22	055A-123	SPACER	1
23	055A-107	SPINDLE SPACER	1
24	055A-106	SPINDLE NUT	1
25		ALLEN GRUB SCREW M5X8	2
26	055A-116	QUILL	---
27		ALLEN GRUB SCREW M5X8	2
28	055A-115	STOP PLATE	---
29		ALLEN SCREW M6X16	---
30		ALLEN SCREW M6X20	6
31		ALLEN SCREW M8X20	---
32		ALLEN GRUB SCREW M5X6	2
33	055A-121	ADJUSTING SCREW	2
34	055A-126	STOP DOG	---
35		COMP. GAS SPRING	1
36	055A-104	NUT	1
37	055A-111	GAS SPRING SUPPORT	1
38		ALLEN GRUB SCREW M4X6	1
39	055A-113	CYL. PIN	1
40	055A-236	LEVEL BLOCK	1
41		ALLEN GRUB SCREW M6X16	1
42		ALLEN SCREW 6-32X5/8" LONG	2
43		CYL. PIN DIA 3/16"X1-1/8" LONG	1
44	055A-237	CLAMP	1
45		ALLEN SCREW M5X12	1
46	055A-238	CLAMP PIN	1
47	055A-240	SPRING	1
48	055A-269	LEVEL SUPPORT	1
49		ALLEN SCREW M8X50	2
50		ALLEN GRUB SCREW M6X12	3
51	055A-239	CLAMP	1
52	055A-247	GAS SPRING SCREW	1
53	055A-248	GAS SPRING SPACER	1
54	055A-228	GAS SPRING SUPPORT	---

S. NO.	PART NO.	DESCRIPTION	QTY
55		ALLEN SCREW M8X20	---
56	055A-257	TOP SEALING RING	---
57		ALLEN HEAD SCREW M6X12	---
58	055A-252	FELT SEAL	---
59	055A-206	NUT	---
60	055A-202	TAPER BUSH	---
61	055A-203	BOTTOM TAPER HOUSING	---
62		ALLEN SCREW M8X16	---
63		ALLEN GRUB SCREW M5X8	---
64	055A-204	TOP TAPER HOUSING	---
65	055A-245	SPINDLE HOUSING	---
66	055A-266	NUT	---
67		EXT. CIRCLIP A16	1
68	055A-268	ECCENTRIC CLAMP	1
69		ADJUSTABLE HANDLE	1
70		CYL. PIN DIA 1/8"X1-1/8" LONG	1
71	055A-219	PIVOT PIN	1
72		ALLEN SCREW M6X12	4
73		PIN DIA 0.093"X0.350" LONG	1
74	055A-286	BOTTOM SEALING RING	---
75		ALLEN HEAD SCREW M6X12	---
76		WIPER	---
77	055-377	LUB. FEEDER	---
78		ALLEN HEAD SCREW M6x30	---
79		OILER	---
80	055A-127	STOP PLATE (M)	1
81	055A-877	DIAL BKT. (M)	1
82	055A-100	QUILL (M)	1
83	055A-171	SPINDLE (M)	1
84	055A-776	PINION SHAFT(M)	1
85	055A-781	END SPACER(M)	1
86	055A-780	HAND WHEEL (M)	1
87	055A-783	GEAR END SPACER(M)	1
88	055A-782	GEAR SPACER(M)	1
89	055A-778	HELICAL GEAR(M)	1
90	055A-779	BUSH(M)	1
91	055A-785	CYL. PIN(M)	1
92	055A-777	ECCENTRIC BUSH(M)	1
93	055A-284	GAS SPRING BRACKET (M)	1
94	555-17-23	INDICATED MTG. BKT. (M)	1
95	555-17-24	INDICATED MTG. ROD (M)	1
96	555-17-25	CLAMP (M)	1
97	VV-80-020	SPACER	1
98	055A-226	FEED DIAL (M)	1
99		THRUST PAD	2
100	055A-291	BRG. HOUSING(M)	1
101	055A-784	WORM(M)	1
102	033-358	STOP ROD BLOCK	1
103	055A-288	CONTROL STOP SCREW (M) WITH KNOB	1
104	-----	-----	---
105	055A-263	SPINDLE HOUSING (M)	1
106	055A-270	NUT(M)	1
107	055A-722	PANEL BOX(M)	1
108	055A-723	MTG. BKT.(M)	1

<b>S. NO.</b>	<b>PART NO.</b>	<b>DESCRIPTION</b>	<b>QTY</b>
109		ALLEN GRUB SCREW M6x15	1
110		ALLEN GRUB SCREW M6x20	1
111		ALLEN HEAD CSK SCREW M8x20	1
112		ALLEN HEAD CAP SCREW M5x12	3
113		ALLEN HEAD CAP SCREW M6x15	1
114		ALLEN HEAD CSK SCREW M6x15	1
115		ALLEN HEAD CAP SCREW M6x12	3
116		ALLEN HEAD CSK SCREW M6x15	2
117		ALLEN HEAD CAP SCREW M8x12	4
118		ALLEN HEAD CAP SCREW M8x20	2
119		ALLEN GRUB SCREW M10x15	4
120		ALLEN HEAD CAP SCREW M10x20	4

### Transmission Assembly Old Design

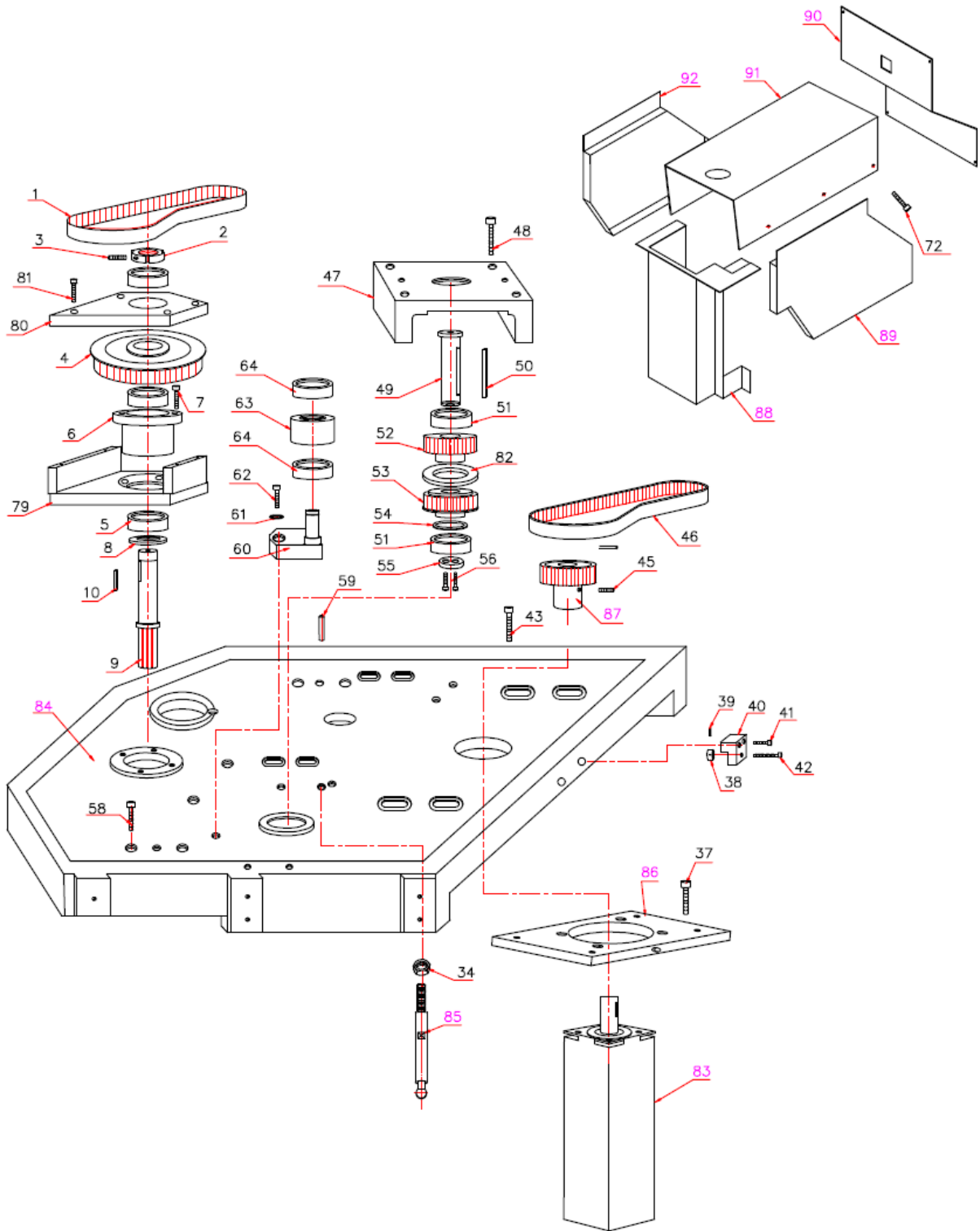

S. NO.	PART NO.	DESCRIPTION	QTY
1		SPINDLE POLY CHAIN BELT	
2	055A-406	SHAFT NUT	1
3		ALLEN GRUB SCREW M5X8	1
4	055A-447	SPINDLE PULLEY	1
5		BALL BEARING 30x62x16-2RS	3
6	055A-449	BEARING HOUSING	1
7		ALLEN SCREW M8X25	4
8	055A-429	BEARING SPACER	1
9	055A-472	DRIVE SHAFT	1
10		PARALLEL KEY 5/16"X5/16"X1-1/4"	1
11	055A-255	TOP PLATE	---
12	055A-422	RING NUT	1
13		ALLEN GRUB SCREW M5X6	1
14	055A-430	BEARING SPACER	---
15	055A-442	BEARING COVER	---
16		ALLEN SCREW M6X12	---
17	055A-441	BEARING HOUSING	---
18		ALLEN SCREW M6X16	---
19		ANGULAR CONTACT BALL BEARING	---
20	055A-443	BEARING SPACER	---
21	055A-444	BEARING SPACER	---
22	055A-427	PULLEY	---
23	055A-445	BALL SCREW	---
24		PARALLEL KEY 1/4"X1/4"X1-5/16"	---
25		EXT. CIRCLIP A12	---
26	055A-425	BEARING HOUSING	---
27		ALLEN SCREW M6X16	---
28		Z-AXIS MOTOR	---
29	055A-405	MOTOR SUPPORT	---
30		ALLEN SCREW M6X20	---
31	055A-409	MOTOR PULLEY	---
32		ALLEN GRUB SCREW M5X8	---
33	055A-223	PLATE SUPPORT	---
34		HEX NUT M12	1
35		SPINDLE MOTOR	---
36	055A-407	MOTOR PLATE	---
37		ALLEN SCREW M10X25	4
38	055A-254	SPACER	1
39		CYLINDRICAL PIN DIA 1/8"X5/8" LONG	1
40	055A-253	ADJUSTING BLOCK	1
41		ALLEN SCREW M6X30	1
42		ALLEN SCREW M8X50	1
43		ALLEN SCREW M10X30	4
44	055A-438	MOTOR PULLEY	---
45		ALLEN GRUB SCREW M6X10	1
46		MOTOR POLY CHAIN BELT	1
47	055A-256	BEARING SUPPORT	1
48		ALLEN SCREW M10X70	4
49	055A-440	INT. SHAFT	1
50		PARALLEL KEY 5/16"X5/16"X3"	1
51		BALL BEARING	2
52	055A-448	UPPER INT. PULLEY	1
53	055A-439	LOWER INT. PULLEY	1
54		INT. CIRCLIP B 62	1



S. NO.	PART NO.	DESCRIPTION	QTY
55	055A-435	BEARING SPACER	1
56		ALLEN SCREW M6X15	2
57		ALLEN SCREW M6X20	---
58		ALLEN SCREW M10X25	4
59	055A-265	TAPER PIN	2
60	055A-478	IDLER SUPPORT	1
61		EXT. CIRCLIP A20	1
62		ALLEN SCREW M12X35	1
63	055A-436	IDLER PULLEY	1
64		BALL BEARING	2
65		BALL BEARING	---
66		TIMING BELT	---
67	055A-700	TOP COVER	---
68	055A-701	RIGHT COVER	---
69	055A-702	LEFT COVER	---
70	055A-703	BACK COVER	---
71	055A-705	FRONT COVER	---
72		ALLEN BUTTON SCREW M5X6	26
73	055A-283	BLOCK	---
74		ALLEN SCREW M8X25	---
75		ALLEN SCREW M8X35	---
76	055A-446	BALL SCREW BRACKET	---
77		ALLEN SCREW M5X16	---
78	055A-338	LUB. CONNECTOR	---
79	055A-474	BEARING SUPPORT	1
80	055A-475	BEARING COVER	1
81		ALLEN HEAD CAP SCREW M8x20	4
82	055A-335	PULLEY SPACER	1
83	-----	SPINDLE MOTOR	1
84	055A-227	TOP PLATE (M)	1
85	055A-340	PLATE SUPPORT (M)	1
86	055A-476	MOTOR PLATE(M)	1
87	055A-477	MOTOR PULLEY(M)	1
88	055A-720	FRONT COVER(M)	1
89	055A-751	RIGHT COVER(M)	1
90	055A-753	BACK COVER(M)	1
91	055A-725	TOP COVER(M)	1
92	055A-752	LEFT COVER(M)	1

### Head Support Assembly Old Design

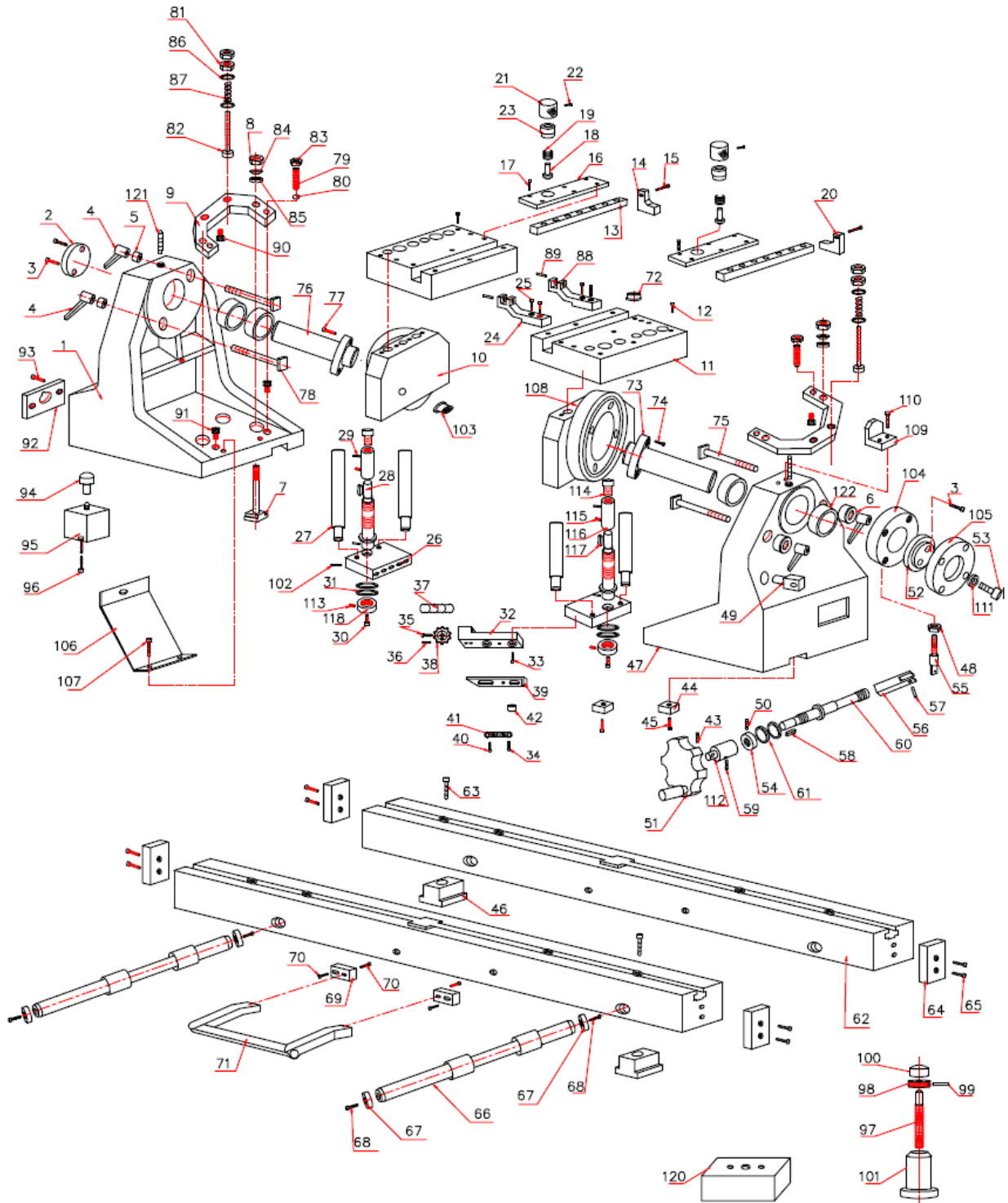

S. NO.	PART NO.	DESCRIPTION	QTY. SG-80M
1	055A-678	CRADLE LEFT	1
2	055A-662	SPACER	1
3		ALLEN HEAD SCREW M6X12	4
4		ADJUSTABLE HANDLE	4
5	055A-663	SPACER	2
6	055A-660	SPACER	2
7	055A-676	T-BOLT	4
8		NYLOCK HEX NUT M12	4
9	055A-671	CLAMPING BRACKET	2
10	055A-657	CRADLE HOLDER (LEFT)	1
11	055A-573	SUPPORT PLATE	2
12		ALLEN SCREW M10X30	8
13	430-940	FLAT	2
14	430-937	STOP PLATE (L. H)	1
15		ALLEN SCREW M6 X 20	2
16	055A-527	COVER PLATE	2
17		ALLEN CSK SCREW M5X12	12
18	430-919	PLUNGER	2
19	430-921	SPRING (NO. 100-057)	2
20	430-935	STOP PLATE (R.H)	1
21	430-918	KNURLING COLLAR	2
22		ALLEN SCREW M6 X 6	2
23	430-916	PIN HOLDER	2
24	055A-569	CHAIN BLOCK-A	2
25		ALLEN SCREW M10X35	8
26	055A-579	CLAMP PLATE	2
27	055A-588	GUIDE ROD	4
28	055A-638	SCREW ROD	2
29		CYLINDRICAL PIN DIA. 4 x 20 LONG	2
30		ALLEN HEAD SCREW M12 x 25	2
31		NEEDLE THRUST BEARING 20 x 34 x 4	4
32	055A-576	SPROCKET SUPPORT	4
33		ALLEN HEAD SCREW M10X20	8
34		ALLEN BUTTON HEAD SCREW M5X10	12
35		ALLEN SCREW M8X20	4
36		DOWEL PIN DIA 1/8"X58" LONG	4
37		ROLLER CHAIN	1
38	055A-556	SPROCKET	4
39	055A-564	TOP PLATE	4
40		ALLEN BUTTON HEAD SCREW M5X6	4
41	055A-557	TENSION SPRING	4
42	055A-565	BUSH	12
43		ALLEN HEAD GRUB SCREW M6x10	1
44	055A-623	TENON	4
45		ALLEN SCREW M5X12	4
46	055A-619	T-NUT	12
47	055A-679	CRADLE RIGHT	1
48		HEX NUT M10	1
49	055A-519	PIVOT	1
50		ALLEN GRUB SCREW M5x6	1
51	055A-882	HAND WHEEL	1
52	055A-885	SPACER	1
53		ALLEN HEAD SCREW M12X40	4

S. NO.	PART NO.	DESCRIPTION	QTY. SG-80M
54	055A-880	RING NUT	1
55	055A-878	ARM	1
56	055A-634	ADJUSTER	1
57		SPRING DOWEL PIN DIA 1/8"X5/8" LONG	1
58		PARALLEL KEY 1/8"x1/8"x5/8"LONG	1
59		ALLEN HEAD GRUB SCREW M6x6	1
60	055A-879	PIVOT ROD	1
61		NEEDLE THRUST BEARING 17x30x4	2
62	055A-654	PARALLEL BAR	2
63		ALLEN SCREW M12X60	8
64	055A-590	END STOPPER	4
65		ALLEN SCREW M6X12	8
66	055A-675	GUIDE ROD	2
67	055A-560	END COVER	4
68		ALLEN SCREW M8X16	4
69	055A-595	HANDLE BLOCK	2
70		ALLEN SCREW M8X16	4
71		INCLIND TUBLAR HANDLE	1
72	055A-626	PLUG	4
73	055A-658	HOLDER SHAFT RIGHT	1
74		ALLEN SCREW M10X20	4
75	055A-670	T-BOLT	2
76	055A-659	HOLDER SHAFT LEFT	1
77		ALLEN SCREW M10X20	4
78	055A-669	T-BOLT	2
79	055A-674	SET-SCREW	4
80		STEEL BALL DIA 6MM	4
81		HEX NUT M8	4
82		ALLEN HEAD SCREW M8X90	4
83		HEX NUT M12	2
84	055A-323	SPHERICAL WASHER	4
85	055A-324	SPHERICAL WASHER	4
86		WASHER M8	8
87	282580	COMP. SPRING	4
88	055A-625	CHAIN BLOCK-B	2
89	055A-567	PIN	12
90	055A-635	PIVOT	2
91	055A-672	PIVOT	4
92	055A-645	VALVE PLATE	2
93		ALLEN CSK SCREW M6X12	4
94	055A-673	CYLINDER EXTENSION	2
95		PNEUMATIC CYLINDER	2
96		ALLEN HEAD SCREW M8X75	8
97	055A-682	JACK SCREW	1
98	055A-683	JACK COLLAR	1
99		CYLINDRICAL PIN DIA 1/8"X1-1/2" LONG	1
100	055A-681	JACK TOP	1
101	055A-680	JACK BASE	1
102		ALLEN GRUB SCREW M6X6	4
103	055A-661	PLUG	2
104	055A-883	COLLER	1
105	055A-884	LOCKING SPACER	1
106	055A-718	CRADLE COVER	2
107		ALLEN BUTTON HEAD SCREW M5X10	6

S. NO.	PART NO.	DESCRIPTION	QTY. SG-80M
108	055A-694	CRADLE HOLDER (RIGHT)	1
109	055A-695	ZERO MARK	1
110		ALLEN HEAD CAP SCREW M6X16	2
111	055A-886	WASHER	4
112	055A-881	SHAFT EXTENSION	1
113		ALLEN GRUB SCREW M5x6	2
114		ALLEN HEAD SCREW M12x16	2
115		ALLEN GRUB SCREW M6x10	2
116	055A-639	SHAFT EXTENSION	2
117		PARALLEL KEY 3/16"x3/16"x1/2	2
118	055A-640	RING NUT	2
119	055A-654-S	PARALLEL BAR SCALE	1 SET
120	055A-606	HEIGHT BLOCK	2
121	055A-668	SET SCREW	2
122	055A-122	NEEDLE BEARING	4



**SG80M Pneumatic Drawing Old Design**

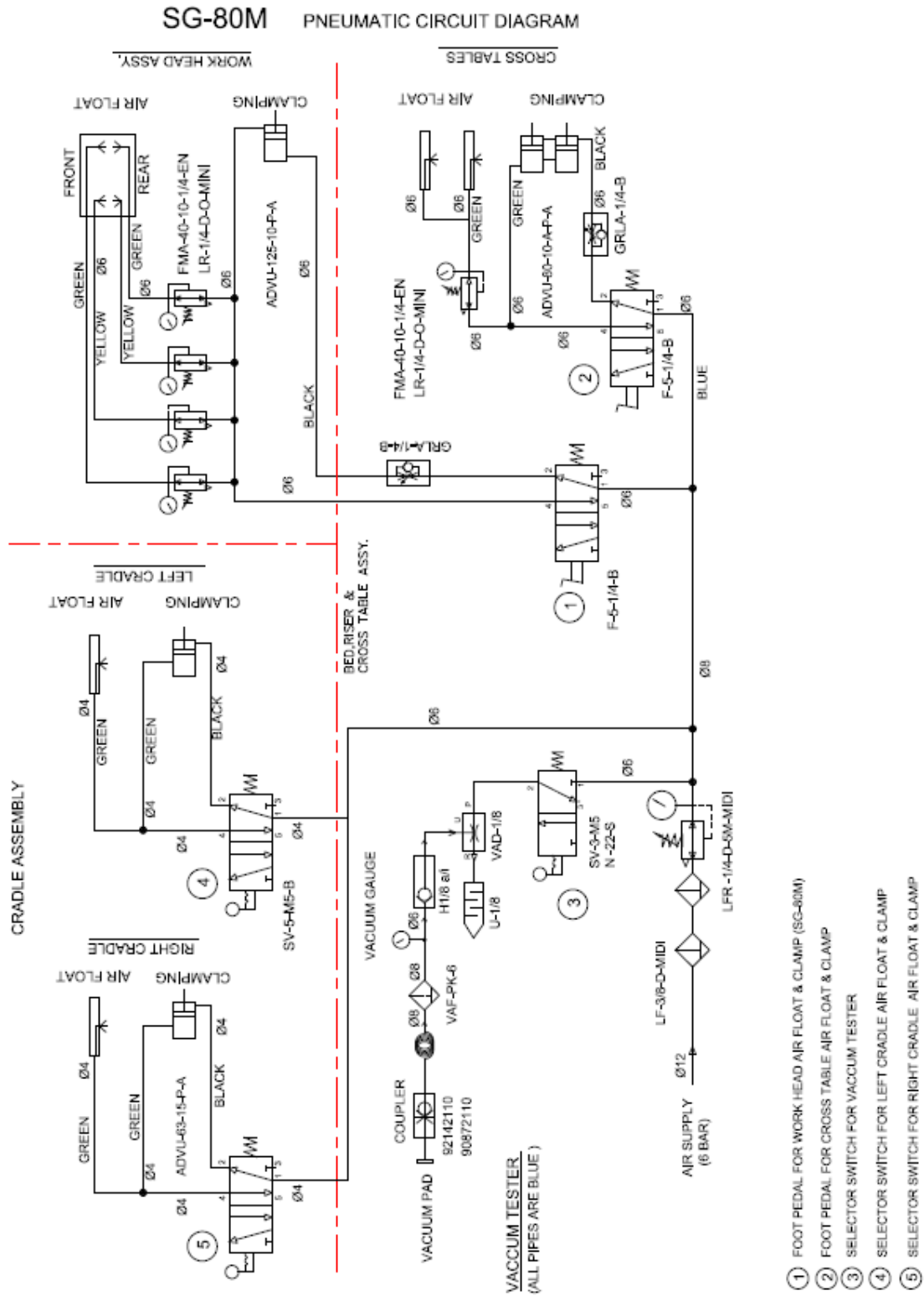

### Bed, Table, and Riser Assembly New Design

#### SG-80A, SG-80M & SG-80MTS BED, TABLE & RISER ASSEMBLY (M)

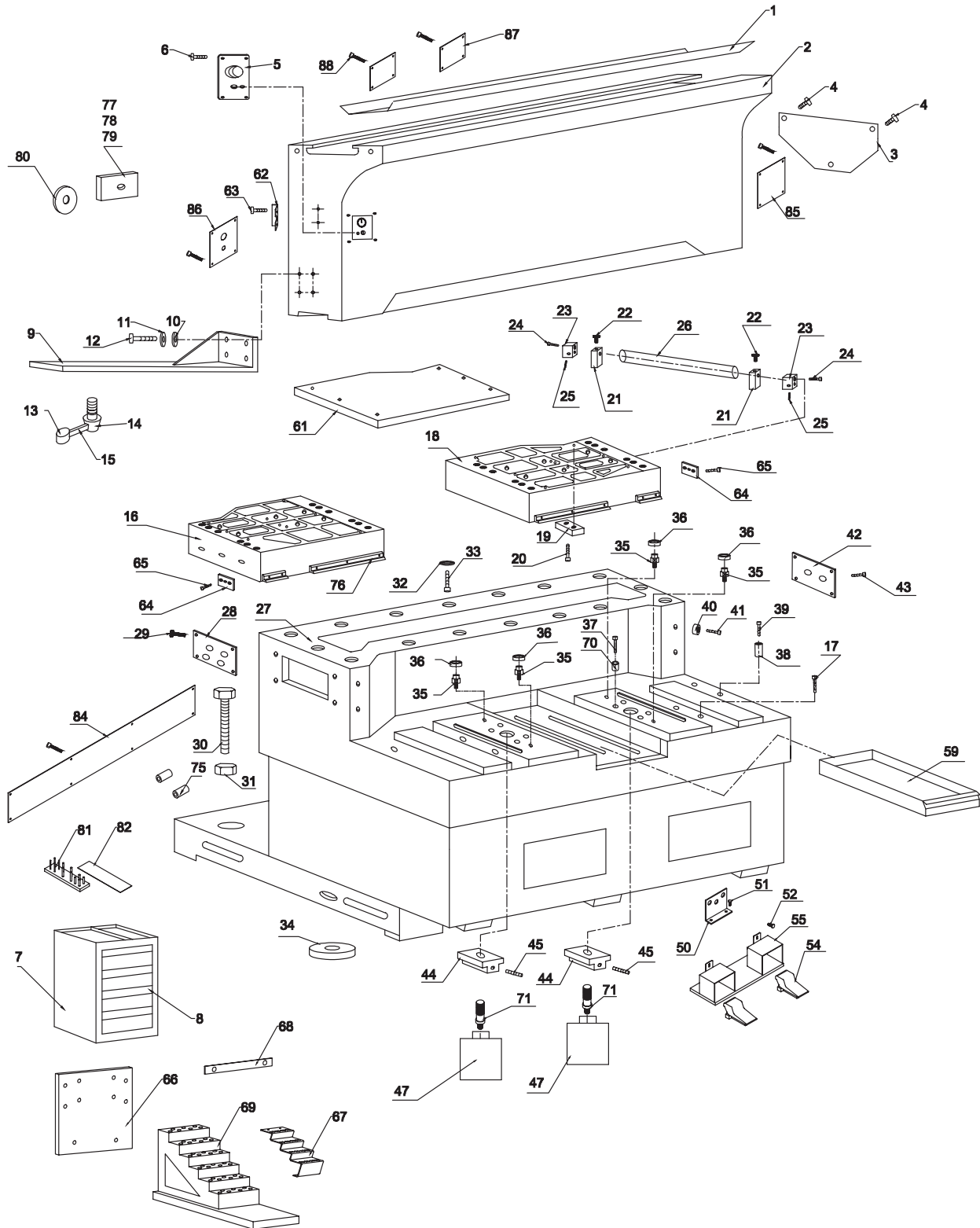

S. NO.	PART NO.	DESCRIPTION	QTY.		
			SG-80A	SG-80M	SG-80MTS
1	055A-550	PAN COVER	1	1	1
2	055A-500	RISER	1	1	1
3	055A-719	END COVER	2	2	2
4		ALLEN BUTTON HEAD SCREW M6X12	4	4	4
5	055A-546	NAME PLATE	1	1	1
6		ALLEN BUTTON HEAD SCREW M6X12	4	4	4
7	<b>055A-760</b>	TOOL CABINET	1	1	1
8		TOOL TRAY	4	4	4
9	430-806	MOUNTING BRACKET	1	1	1
10		PLAIN WASHER M8	5	5	5
11		LOCK WASHER M8	5	5	5
12		HEX. SCREW M8 X 30	4	4	4
13	430-802	BALL (M8x25MM O.D.)	1	1	1
14	430-817	CLAMP PIN	1	1	1
15	430-823	CLAMP LEVER	1	1	1
16	055A-608	LEFT CROSS TABLE	1	1	1
17		ALLEN SCREW M10X20	2	2	2
18	055A-607	RIGHT CROSS TABLE	1	1	1
19	055A-612	STOPPER	2	2	2
20		ALLEN SCREW M6X20	4	4	4
21	055A-528	STOP DOG	2	2	2
22	055A-551	THUMB SCREW	2	2	2
23	055A-529	SUPPORT	2	2	2
24		ALLEN SCREW M6X30	2	2	2
25		ALLEN GRUB SCREW M5X8	2	2	2
26	055A-615	STOPPER ROD	1	1	1
27	055A-611	CABINET	1	1	1
28	055A-617	NAME PLATE	1	1	1
29		ALLEN BUTTON HEAD SCREW M6X12	4	4	4
30	430-818	HEX HEAD SCREW M16X70	5	5	5
	430-818A	HEX HEAD SCREW M16X180	1	1	1
31		HEX NUT M16	6	6	6
32		MACHINED WASHER M12	16	16	16
33		ALLEN SCREW M12X35	16	16	16
34	430-819	PAD	6	6	6
35	055A-516	BEARING PIN	4	4	4
36		BALL BEARING	4	4	4
37		ALLEN SCREW M10X55	8	8	8
38	055A-613	STOPPER	1	1	1
39		ALLEN SCREW M8X35	1	1	1
40	055A-602	NYLON STOPPER	2	2	2
41		ALLEN SCREW M8X16	2	2	2
42	055A-708	NAME PLATE	1	1	1
43		ALLEN BUTTON HEAD SCREW M6X12	4	4	4
44	055A-515	T-NUT	2	2	2
45		ALLEN GRUB SCREW M5X8	2	2	2
46	-----	-----	-----	-----	-----
47		PNEUMATIC CYLINDER	2	2	2
48	-----	-----	-----	-----	-----
49	-----	-----	-----	-----	-----
50	055A-652	BULKHEAD BRACKET	-----	2	-----
51		ALLEN HEAD SCREW M6X12	6	4	6
52		ALLEN HEAD SCREW M8X16	-----	2	-----
53	055A-762	BRACKET	2	-----	2

S. NO.	PART NO.	DESCRIPTION	QTY.		
			SG-80A	SG-80M	SG-80MTS
54		FOOT SWITCH	-----	2	----
55	055A-650	FOOT SWITCH HOUSING	-----	1	-----
56	-----	-----	-----	-----	-----
57	-----	-----	-----	-----	-----
58	-----	-----	-----	-----	-----
59	055A-709-3	CHIPS TRAY	1	1	1
60	-----	-----	-----	-----	-----
61	055A-709-7	CROSS TABLE COVER	2	2	2
62	033-069	BRACKET	1	1	1
63		ALLEN SCREW M6X12	2	2	2
64	055A-664	PLATE	2	2	2
65		ALLEN CSK HEAD SCREW M6 X 12	4	4	4
66	<b>055A-757</b>	SUPPORT PLATE	1	1	1
67	<b>055A-756</b>	STAND	1	1	1
68	430-839-4	NAME PLATE	1	1	1
69	<b>055A-758</b>	PILOT STAND	1	1	1
70	055A-641	CYL. SPACER	8	8	8
71	055A-642	CYL. STUD	2	2	2
72.	-----	-----	-----	-----	-----
73.	-----	-----	-----	-----	-----
74.	-----	-----	-----	-----	-----
75.	055A-712	CONTROL BOX SPACER	-----	2	-----
76.	055A-697	WIPERS	1 SET	1 SET	1 SET
77	101A-109	VACUUM PAD	1	1	1
78	101A-110	VACUUM PAD	1	1	1
79	101A-111	VACUUM PAD	1	1	1
80	101A-112	VACUUM PAD	1	1	1
81	055A-759	TOOL BOARD (L.H.) WITH PINS	1	1	1
82	055A-755	RUBBER SHEET	1	1	1
<b>83</b>	<b>055A-770</b>	<b>BRACKET</b>	<b>1</b>	<b>----</b>	<b>1</b>
<b>84</b>	<b>055A-709-2</b>	<b>CABINET COVER</b>	<b>1</b>	<b>1</b>	<b>1</b>
<b>85</b>	<b>055A-709-5</b>	<b>RISER COVER</b>	<b>1</b>	<b>1</b>	<b>1</b>
<b>86</b>	<b>055A-709-6</b>	<b>RISER COVER</b>	<b>1</b>	<b>1</b>	<b>1</b>
<b>87</b>	<b>055A-709-1</b>	<b>RISER COVER</b>	<b>2</b>	<b>2</b>	<b>2</b>
<b>88</b>		<b>BUTTON HEAD SCREW M6x10</b>	<b>24</b>	<b>24</b>	<b>24</b>

**Base Assembly New Design**

**SG-80A, SG-80M & SG-80MTS  
BASE ASSEMBLY (SPINDLE HOUSING WITHOUT TAPER BUSHING)**

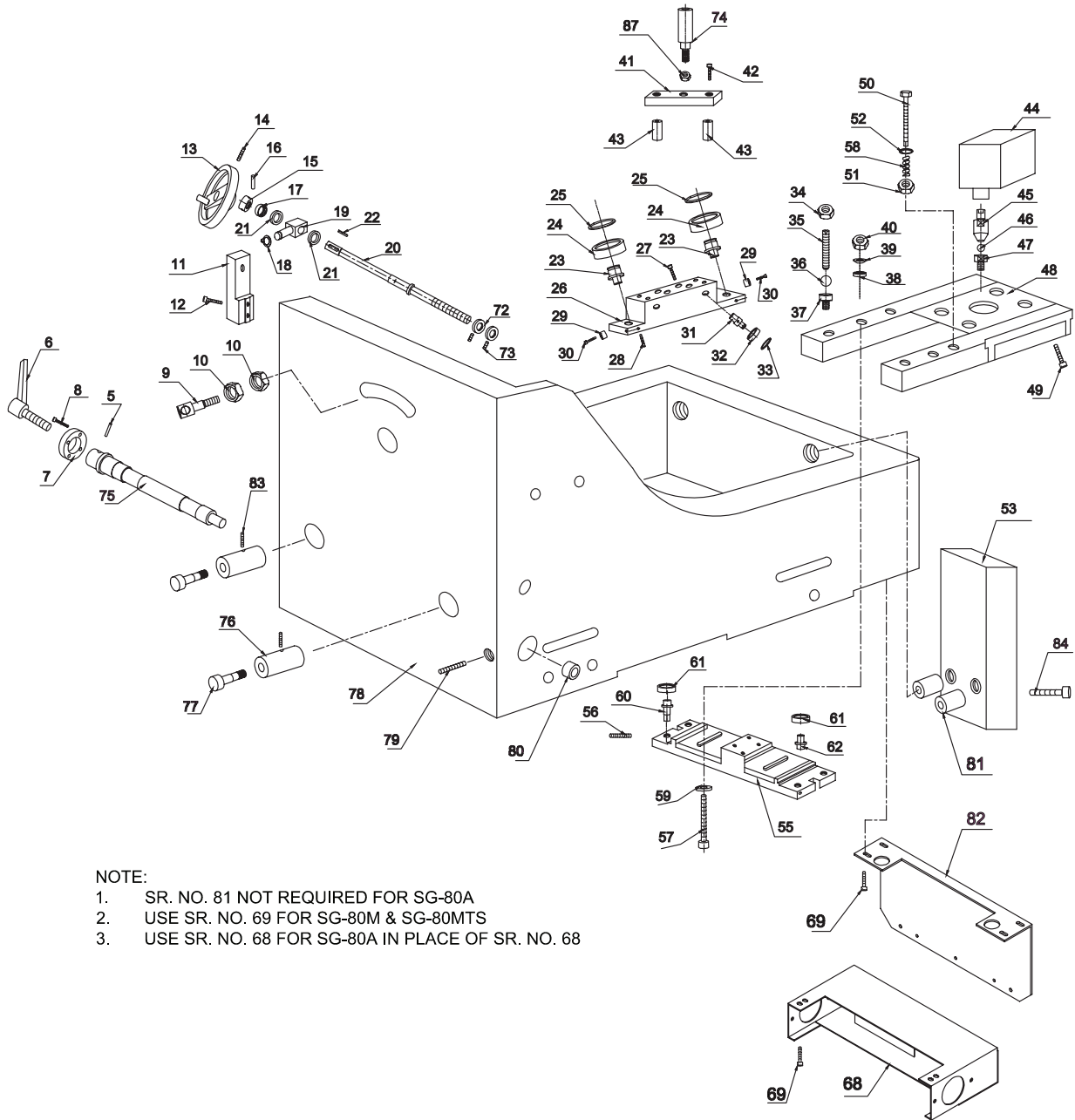

**NOTE:**

1. SR. NO. 81 NOT REQUIRED FOR SG-80A
2. USE SR. NO. 69 FOR SG-80M & SG-80MTS
3. USE SR. NO. 68 FOR SG-80A IN PLACE OF SR. NO. 69



S. NO.	PART NO.	DESCRIPTION	QTY.		
			SG-80A	SG-80M	SG-80MTS
1					
2					
3					
4					
5		CYLINDRICAL PIN DIA. 1/8"X1-1/8" LONG	1	1	1
6		ADJUSTABLE HANDLE	1	1	1
7	055A-321	SPACER HOUSING	1	1	1
8		ALLEN SCREW M6X16	4	4	4
9	055A-264	LOCATING BOLT	1	1	1
10	055A-320	NUT	2	2	2
11	055A-327	SCREW BLOCK	1	1	1
12		ALLEN SCREW M8X35	2	2	2
13	055A-311	HAND WHEEL	1	1	1
14		ALLEN GRUB SCREW M6X10	1	1	1
15	055A-309	SPACER	1	1	1
16		SPRING DOWEL DIA. 1/8"X1-1/8" LONG	1	1	1
17		NEEDLE ROLLER BEARING	1	1	1
18		EXT. CIRCLIP A16	1	1	1
19	055A-304	GUIDE PIN	1	1	1
20	055A-310	INCNCILATION ROD	1	1	1
21		NEEDLE THRUST BEARING	2	2	2
22		PARALLEL KEY 3/16"X3/16"X7/8"	1	1	1
23	055A-502	BEARING PIN	2	2	2
24		BALL BEARING	2	2	2
25		EXT. CIRCLIP A25	2	2	2
26	055A-344	CROSS BEARING SUPPORT	1	1	1
27		ALLEN SCREW M6X55	4	4	4
28		ALLEN GRUB SCREW M5X8	6	6	6
29	055A-305	STOPPER	2	2	2
30		ALLEN SCREW M5X12	2	2	2
31	055A-501	BEARING PIN	4	4	4
32		BALL BEARING	4	4	4
33		EXT. CIRCLIP A10	4	4	4
34		HEX NUT M12	2	2	2
35	055A-308	SET SCREW	2	2	2
36		STEEL BALL DIA 1/4"	2	2	2
37	055A-301	PIVOT	2	2	2
38	055A-324	SPHERICAL WASHER	2	6	6
39	055A-323	SPHERICAL WASHER	2	6	6
40		NYLOCK HEX NUT M12	2	2	2
41	055A-316	SWIVEL BRACKET	1	1	1
42		ALLEN SCREW M6X55	2	2	2
43	055A-315	SPACER	2	2	2
44		PNEUMATIC CYLINDER	1	1	1
45	055A-306	PIVOT PIN	1	1	1
46		STEEL BALL DIA 3/8"	1	1	1
47	055A-303	BALL SUPPORT	1	1	1
48	055A-322	CLAMPING BRACKET	1	1	1
49		ALLEN SCREW M12X30	4	4	4
50		HEX HEAD SCREW M8X100	2	2	2
51		HEX NUT M8	2	2	2
52		WASHER M8	2	2	2
53	055A-627	WEIGHT	1	1	1
54		ALLEN SCREW M12X75	2	---	---

S. NO.	PART NO.	DESCRIPTION	QTY.		
			SG-80A	SG-80M	SG-80MTS
55	055A-343	CLAMPING PLATE	1	1	1
56		ALLEN GRUB SCREW M5X8	4	4	4
57		HEX HEAD SCREW M12X180	2	2	2
58	282580	COMP. SPRING	2	2	2
59	055A-325	SPACER	2	2	2
60	055A-312	BEARING PIN	2	2	2
61		BALL BEARING	4	4	4
62	055A-313	BEARING PIN	2	2	2
63					
64					
65					
66					
67					
68	055A-710	CABLE TRAY WITH COVER	1	---	---
69		ALLEN SCREW M6X12	4	---	---
70	-----	-----	---	---	---
71	-----	-----	---	---	---
72	055A-342	STOP COLLAR	2	2	2
73		ALLEN SET SCREW M6X12	2	2	2
74	055A-341	TIE ROD SUPPORT	1	1	1
75	055A-334	ECCENTRIC SHAFT	1	1	1
76	055A-336	CLAMPING BLOCK	2	2	2
77	055A-339	CLAMPING BOLT	2	2	2
78	055A-333	BASE	1	1	1
79		ALLEN HEAD SET SCREW	2	2	2
80	055A-345	ECCENTRIC BUSH	1	1	1
81	055A-629	WEIGHT SPACER (M)	---	2	2
82	055A-346	CONDUIT PLATE (M)	---	1	1
83		ALLEN HEAD GRUB SCREW M6x15	---	2	2
84		ALLEN HEAD CAP SCREW M12x115	---	2	2
85	430-637 R	KNOB	1	1	1
<b>87</b>		<b>HEX. NUT M12</b>	<b>1</b>	<b>1</b>	<b>1</b>

### Spindle Housing Assembly New Design

SG-80A, SG-80M & SG-80MTS  
SPINDLE HOUSING ASSEMBLY (M)

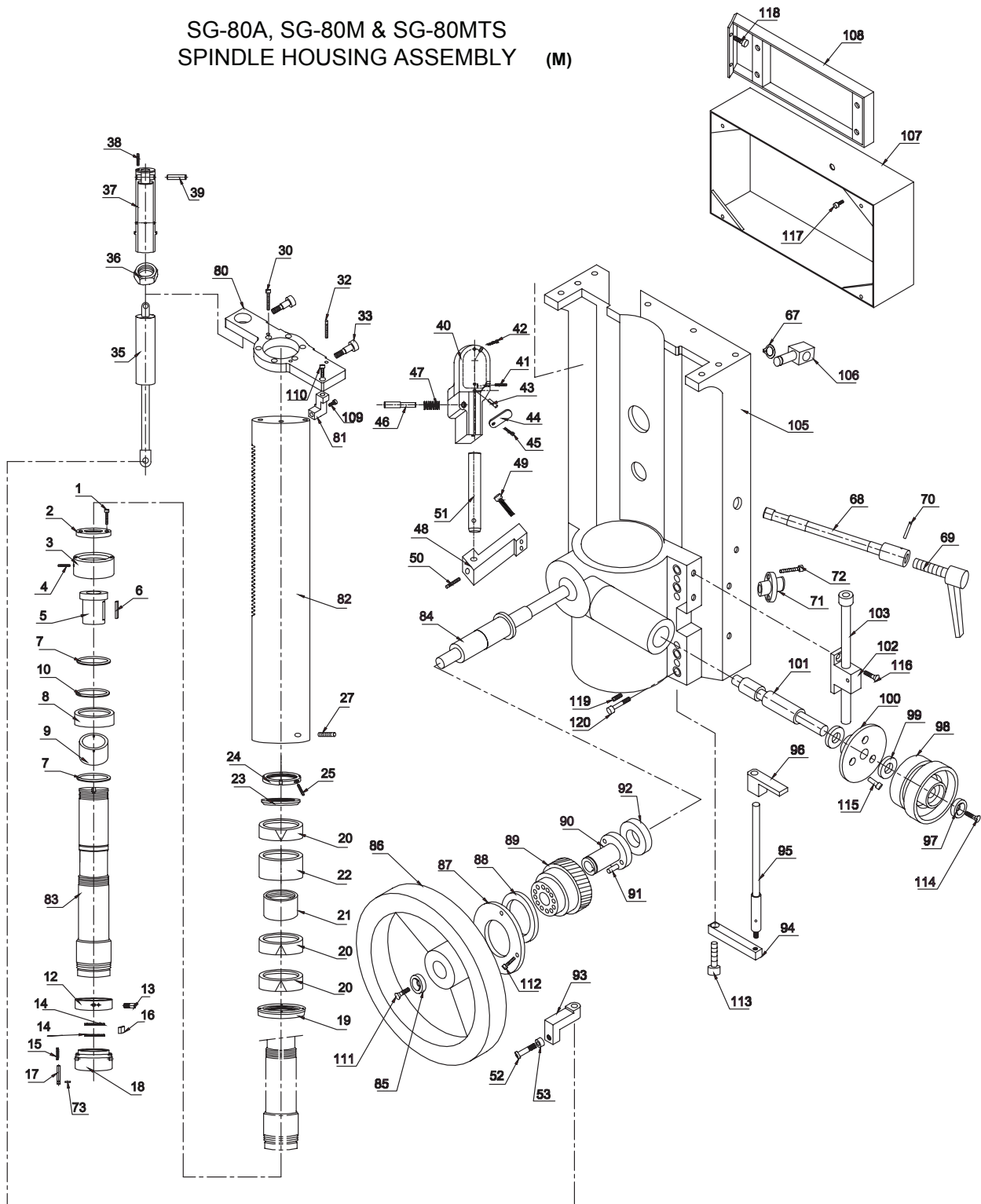

S. NO.	PART NO.	DESCRIPTION	QTY.		
			SG-80A	SG-80M	SG-80MTS
1		ALLEN SCREW M5X12	2	2	2
2	055A-103	NYLON STOPPER	1	1	1
3	055A-105	NUT	1	1	1
4		ALLEN GRUB SCREW M5X8	1	1	1
5	055A-404	SPLINE BUSH	1	1	1
6		PARALLEL KEY 1/4"X1/4"X1-1/2"	1	1	1
7		EXT. CIRCLIP A48	2	2	2
8		NEEDLE ROLLER BEARING	1	1	1
9	055A-122	BEARING SUPPORT	1	1	1
10		EXT. CIRCLIP A55	1	1	1
11					
12	KS-09-06	COVER	1	1	1
13	KS-08-01	STOP PIN	1	1	1
14	KS-09-03	COMP. SPRING	2	2	2
15	KS-08-04	COMP. SPRING	1	1	1
16	KS-08-02	PAD	1	1	1
17	KS-08-05	PIN	1	1	1
18	KS-09-07	NUT	1	1	1
19	055A-102	QUILL NUT	1	1	1
20		ANGULAR CONTACT BALL BEARING	3	3	3
21	055A-124	SPACER	1	1	1
22	055A-123	SPACER	1	1	1
23	055A-107	SPINDLE SPACER	1	1	1
24	055A-106	SPINDLE NUT	1	1	1
25		ALLEN GRUB SCREW M5X8	2	2	2
26	055A-189	QUILL	1	---	---
27		ALLEN GRUB SCREW M5X8	2	2	2
28	055A-190	STOP PLATE	1	---	---
29		ALLEN SCREW M6X16	1	---	---
30		ALLEN SCREW M6X20	6	6	6
31		ALLEN SCREW M8X20	4	---	---
32		ALLEN GRUB SCREW M5X6	2	2	2
33	055A-121	ADJUSTING SCREW	2	2	2
34	055A-126	STOP DOG	1	---	---
35		COMP. GAS SPRING	1	1	1
36	055A-104	NUT	1	1	1
37	055A-111	GAS SPRING SUPPORT	1	1	1
38		ALLEN GRUB SCREW M4X6	1	1	1
39	055A-113	CYL. PIN	1	1	1
40	055A-236	LEVEL BLOCK	1	1	1
41		ALLEN GRUB SCREW M6X16	1	1	1
42		ALLEN SCREW 6-32X5/8" LONG	2	2	2
43		CYL. PIN DIA 3/16"X1-1/8" LONG	1	1	1
44	055A-237	CLAMP	1	1	1
45		ALLEN SCREW M5X12	1	1	1
46	055A-238	CLAMP PIN	1	1	1
47	055A-240	SPRING	1	1	1
48	----	----	----	----	----
49		ALLEN SCREW M8X50	2	2	2
50		ALLEN GRUB SCREW M6X12	3	3	3
51	055A-239	CLAMP	1	1	1
52	055A-247	GAS SPRING SCREW	1	1	1
53	055A-248	GAS SPRING SPACER	1	1	1
54	055A-295	GAS SPRING HOLDER	1	---	---

S. NO.	PART NO.	DESCRIPTION	QTY.		
			SG-80A	SG-80M	SG-80MTS
55					
56					
57					
58					
59					
60					
61					
62		ALLEN CAP SCREW M6x30	1	---	---
63					
64					
65	055A-297	SPINDLE HOUSING	1	---	---
66	<b>055A-354</b>	NUT	1	---	---
67		EXT. CIRCLIP A16	1	1	1
68	055A-268	ECCENTRIC CLAMP	1	1	1
69		ADJUSTABLE HANDLE	1	1	1
70		CYL. PIN DIA 1/8"X1-1/8" LONG	1	1	1
71	055A-219	PIVOT PIN	1	1	1
72		ALLEN SCREW M6X12	4	4	4
73		PIN DIA 0.093"X0.350" LONG	1	1	1
74					
75					
76					
77	055-337	LUB. FEEDER	1	---	---
78		ALLEN HEAD SCREW M6x30	2	---	---
79		OILER	1	---	---
80	055A-127	STOP PLATE (M)	---	1	---
81	055A-877	DIAL BKT. (M)	---	1	---
82	055A-100	QUILL (M)	---	1	1
83	055A-171	SPINDLE	1	1	1
84	055A-776	PINION SHAFT(M)	---	1	---
85	055A-781	END SPACER(M)	---	1	1
86	055A-780	HAND WHEEL (M)	---	1	1
87	055A-783	GEAR END SPACER(M)	---	1	1
88	055A-782	GEAR SPACER(M)	---	1	1
89	055A-778	HELICAL GEAR(M)	---	1	1
90	055A-779	BUSH(M)	---	1	---
91	055A-785	CYL. PIN(M)	---	1	1
92	055A-761	SPACER (M)	---	1	1
93	055A-284	GAS SPRING HOLDER (M)	---	1	1
94	055A-289	INDICATED MTG. BKT. (M)	---	1	---
95	055A-287	INDICATED MTG. ROD (M)	---	1	---
96	055A-290	CLAMP (M)	---	1	---
97	055A-210	SPACER	---	1	1
98	055A-226	FEED DIAL (M)	---	1	---
99		THRUST PAD	---	2	2
100	055A-291	BRG. HOUSING(M)	---	1	1
101	055A-784	WORM(M)	---	1	---
102	430-606-S	STOP ROD BLOCK	---	1	---
103	055A-288	CONTROL STOP SCREW (M) WITH KNOB	---	1	1
104	-----	-----	---	---	---
105	055A-263	SPINDLE HOUSING (M)	---	1	1
106	055A-270	NUT(M)	---	1	1
107	055A-722	PANEL BOX(M)	---	1	---
108	055A-723	MTG. BKT.(M)	---	1	---

S. NO.	PART NO.	DESCRIPTION	QTY.		
			SG-80A	SG-80M	SG-80MTS
109		ALLEN GRUB SCREW M6x15	---	1	---
110		ALLEN GRUB SCREW M6x20	---	1	---
111		ALLEN HEAD CSK SCREW M8x20	---	1	1
112		ALLEN HEAD CAP SCREW M5x12	---	3	3
113		ALLEN HEAD CAP SCREW M6x15	---	1	---
114		ALLEN HEAD CSK SCREW M6x15	---	1	1
115		ALLEN HEAD CAP SCREW M6x12	---	3	3
116		ALLEN HEAD CSK SCREW M6x15	---	2	---
117		ALLEN HEAD CAP SCREW M8x12	---	4	---
118		ALLEN HEAD CAP SCREW M8x20	---	2	---
119		ALLEN GRUB SCREW M10x15	---	4	4
120		ALLEN HEAD CAP SCREW M10x20	---	4	4
121	055A-131	STOP PLATE	---	---	1
122	055A-282	LEVEL SUPPORT	1	1	1
123	055A-280	PINION SHAFT	---	---	1
124	055A-281	BUSH	---	---	1
125	055A-277	WORM	---	---	1
126	055A-278	WORM SHAFT	---	---	1
127	055A-279	FEED DIAL	---	---	1
128	055A-274	LATCH STOP	---	---	1
129		ALLEN HEAD CAP SCREW M6x20	---	---	2
130	055A-273	LATCH SUPPORT	---	---	1
131		ALLEN HEAD CAP SCREW M6x20	---	---	2
132	055A-275	STOPPER	---	---	1
133		ALLEN HEAD CAP SCREW M6x20	---	---	4
134	055A-276	STOPPER EXTN.	---	---	1
135		ALLEN HEAD CAP SCREW M8x45	---	---	1
136		ALLEN HEAD CAP SCREW M4x20	---	---	1
137	055A-272	HEAD SUPPORT	---	---	1
138		OPTICAL SCALE	---	---	1
139	055A-271	SCALE SUPPORT	---	---	1
140		ALLEN HEAD CAP SCREW M6x25	---	---	3
141	055A-353	GUIDE BUSH	1	---	---
142		ALLEN HEAD CAP SCREW M5x20	2	---	---



### Transmission Assembly New Design

SG-80A, SG-80M & SG-80MTS  
TRANSMISSION ASSEMBLY (M)

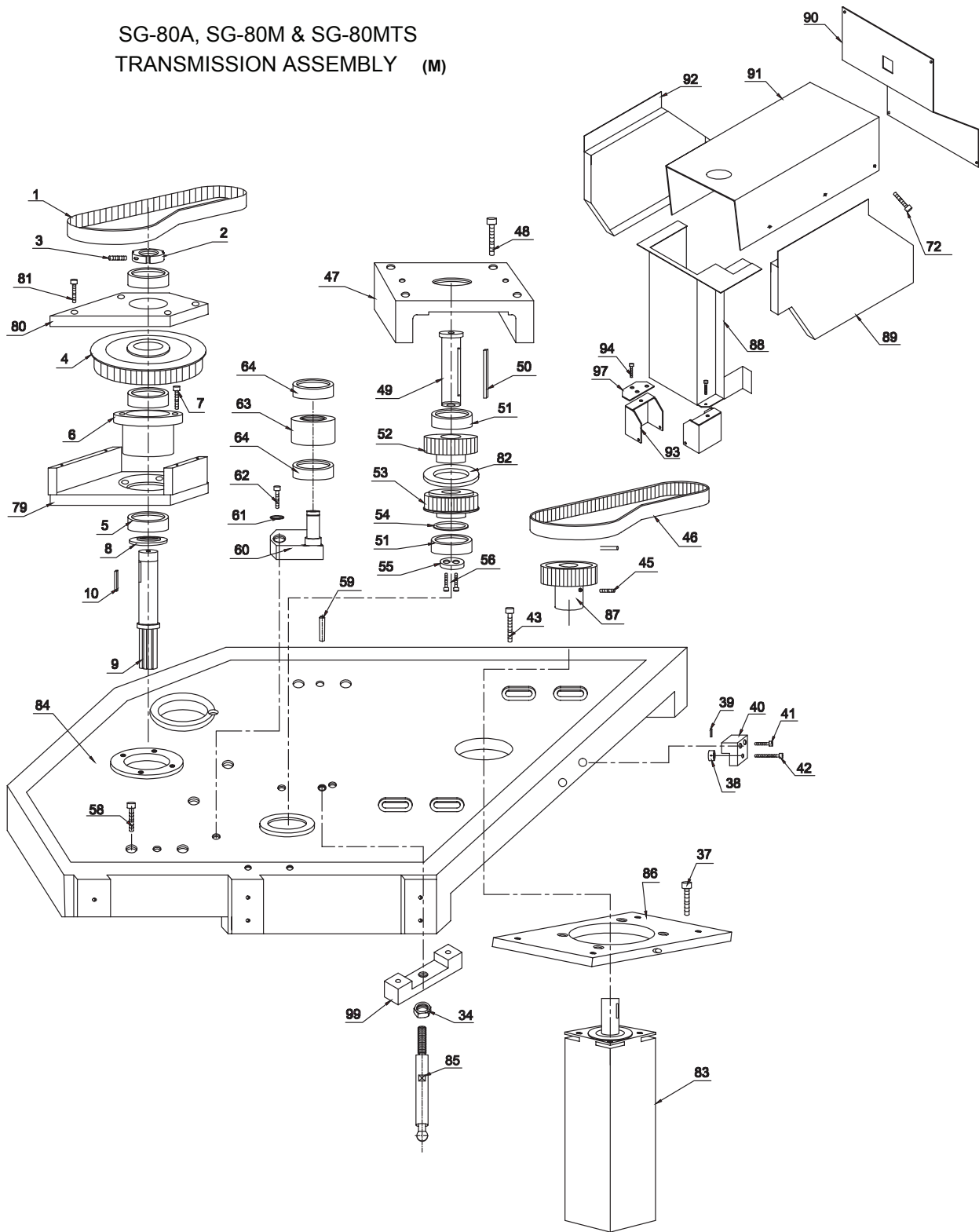

S. NO.	PART NO.	DESCRIPTION	QTY.		
			SG-80A	SG-80M	SG-80MTS
1		SPINDLE POLY CHAIN BELT	1		
2	055A-406	SHAFT NUT	1	1	1
3		ALLEN GRUB SCREW M5X8	1	1	1
4	055A-447	SPINDLE PULLEY	1	1	1
5		BALL BEARING 30x62x16-2RS	3	3	3
6	055A-449	BEARING HOUSING	1	1	1
7		ALLEN SCREW M8X25	4	4	4
8	055A-429	BEARING SPACER	1	1	1
9	055A-472	DRIVE SHAFT	1	1	1
10		PARALLEL KEY 5/16"X5/16"X1-1/4"	1	1	1
11	055A-255	TOP PLATE	1	---	---
12	055A-422	RING NUT	1	1	1
13		ALLEN GRUB SCREW M5X6	1	1	1
14	055A-430	BEARING SPACER	1	---	---
15	055A-442	BEARING COVER	1	---	---
16		ALLEN SCREW M6X12	4	---	---
17	055A-441	BEARING HOUSING	1	---	---
18		ALLEN SCREW M6X16	4	---	---
19		ANGULAR CONTACT BALL BEARING	2	---	---
20	055A-443	BEARING SPACER	1	---	---
21		ALLEN GRUB SCREW M5x8	4		
22	055A-427	PULLEY	1	---	---
23	055A-480	BALL SCREW	1	---	---
24		PARALLEL KEY 1/4"X1/4"X1-5/16"	1	---	---
25		EXT. CIRCLIP A12	1	---	---
26	055A-479	BEARING HOUSING	1	---	---
27		ALLEN SCREW M5X12	4	---	---
28		Z-AXIS MOTOR	1	---	---
29	055A-405	MOTOR SUPPORT	1	---	---
30		ALLEN SCREW M6X20	4	---	---
31	055A-409	MOTOR PULLEY	1	---	---
32		ALLEN GRUB SCREW M5X8	1	---	---
33	-----	-----	---	---	---
34		HEX NUT M12	1	1	1
35		SPINDLE MOTOR	1	---	---
36	055A-407	MOTOR PLATE	1	---	---
37		ALLEN SCREW M10X25	4	4	4
38	055A-254	SPACER	1	1	1
39		CYLINDRICAL PIN DIA 1/8"X5/8" LONG	1	1	1
40	055A-253	ADJUSTING BLOCK	1	1	1
41		ALLEN SCREW M6X30	1	1	1
42		ALLEN SCREW M8X50	1	1	1
43		ALLEN SCREW M10X30	4	4	4
44	055A-438	MOTOR PULLEY	1	---	---
45		ALLEN GRUB SCREW M6X10	1	1	1
46		MOTOR POLY CHAIN BELT	1	1	1
47	055A-256	BEARING SUPPORT	1	1	1
48		ALLEN SCREW M10X70	4	4	4
49	055A-440	INT. SHAFT	1	1	1
50		PARALLEL KEY 5/16"X5/16"X3"	1	1	1
51		BALL BEARING	2	2	2
52	055A-448	UPPER INT. PULLEY	1	1	1
53	055A-439	LOWER INT. PULLEY	1	1	1
54		INT. CIRCLIP B 62	1	1	1

S. NO.	PART NO.	DESCRIPTION	QTY.		
			SG-80A	SG-80M	SG-80MTS
55	055A-435	BEARING SPACER	1	1	1
56		ALLEN SCREW M6X15	2	2	2
57		ALLEN SCREW M6X20	4	---	---
58		ALLEN SCREW M10X25	6	4	4
59		CYL. PIN	2	2	2
60	055A-478	IDLER SUPPORT	1	1	1
61		EXT. CIRCLIP A20	1	1	1
62		ALLEN SCREW M12X35	1	1	1
63	055A-436	IDLER PULLEY	1	1	1
64		BALL BEARING	2	2	2
65		BALL BEARING (6904-2RS) 20 x 37 x 9	1	---	---
66		TIMING BELT	1	---	---
67	055A-700	TOP COVER	1	---	---
68	055A-789	RIGHT COVER	1	---	---
69	055A-790	LEFT COVER	1	---	---
70	055A-703	BACK COVER	1	---	---
71	055A-791	FRONT COVER	1	---	---
72		ALLEN BUTTON SCREW M5X6	26	26	26
73	055A-283	BLOCK	1	---	---
74		ALLEN SCREW M8X25	2	---	---
75		ALLEN SCREW M8X35	1	---	---
76	055A-446	BALL SCREW BRACKET	1	---	---
77		ALLEN SCREW M5X16	5	---	---
78	-----	-----	---	---	---
79	055A-474	BEARING SUPPORT	1	1	1
80	055A-475	BEARING COVER	1	1	1
81		ALLEN HEAD CAP SCREW M8x20	4	4	4
82	055A-335	PULLEY SPACER	1	1	1
83	-----	SPINDLE MOTOR	---	1	1
84	055A-227	TOP PLATE (M)	---	1	1
85	055A-340	PLATE SUPPORT	1	1	1
86	055A-476	MOTOR PLATE(M)	---	1	1
87	055A-477	MOTOR PULLEY(M)	---	1	1
88	055A-720	FRONT COVER(M)	---	1	---
89	055A-751	RIGHT COVER(M)	---	1	1
90	055A-753	BACK COVER(M)	---	1	1
91	055A-725	TOP COVER(M)	---	1	1
92	055A-752	LEFT COVER(M)	---	1	1
93	055A-713	LIGHT BRACKET	---	2	2
94		ALLEN HEAD SCREW M6x10	---	4	4
95	055A-714	DUST COVER	1	---	---
96		ALLEN HEAD SCREW M6x10	4	---	---
97	055A-749	LIGHT BRACKET	---	1	2
98	055A-220	SUPPORT PLATE	1	---	---
99	055A-221	SUPPORT PLATE (M)	---	1	1
100	055A-763	FRONT COVER	---	---	1
101		ALLEN BUTTON HEAD SCREW M6x10	---	---	16
102	055A-765	TOP COVER	---	---	1
103	055A-768	ZERO MARK	---	---	1
104		ALLEN BUTTON HEAD SCREW M4x6	---	---	2
105	055A-764	PANEL PLATE	---	---	1
106		ALLEN BUTTON HEAD SCREW M6x10	---	---	4

### Head Support and Cradle Assembly New Design

SG-80A, SG-80M & SG-80MTS HEAD SUPPORT & CRADLE ASSEMBLY  
(SPINDLE HOUSING WITHOUT TAPER BUSHING)

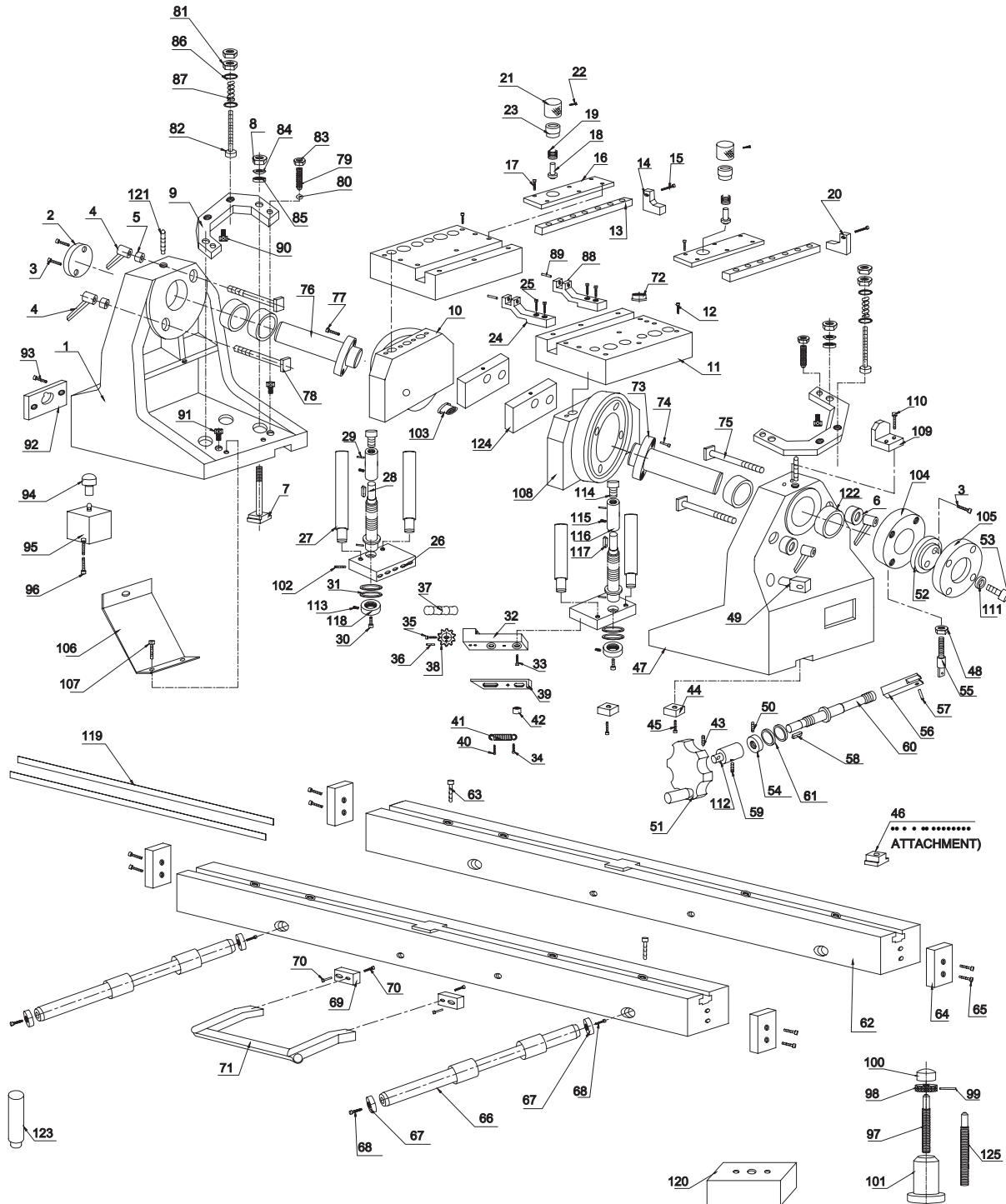

S. NO.	PART NO.	DESCRIPTION	QTY.
			SG-80A, SG-80M & SG-80MTS
1	055A-678	CRADLE LEFT	1
2	055A-662	SPACER	1
3		ALLEN HEAD SCREW M6X12	4
4		ADJUSTABLE HANDLE	4
5	055A-663	SPACER	2
6	055A-660	SPACER	2
7	055A-676	T-BOLT	4
8		NYLOCK HEX NUT M12	4
9	055A-671	CLAMPING BRACKET	2
10	055A-657	CRADLE HOLDER (LEFT)	1
11	055A-573	SUPPORT PLATE	2
12		ALLEN SCREW M10X30	8
13	430-940	FLAT	2
14	430-937	STOP PLATE (L. H)	1
15		ALLEN SCREW M6 X 20	2
16	055A-527	COVER PLATE	2
17		ALLEN CSK SCREW M5X12	12
18	430-919	PLUNGER	2
19	430-921	SPRING (NO. 100-057)	2
20	430-935	STOP PLATE (R.H)	1
21	430-918	KNURLING COLLAR	2
22		ALLEN SCREW M6 X 6	2
23	430-916	PIN HOLDER	2
24	055A-569	CHAIN BLOCK-A	2
25		ALLEN SCREW M10X35	8
26	055A-579	CLAMP PLATE	2
27	055A-588	GUIDE ROD	4
28	055A-638	SCREW ROD	2
29		CYLINDRICAL PIN DIA. 4 x 20 LONG	2
30		ALLEN HEAD SCREW M12 x 25	2
31		NEEDLE THRUST BEARING 20 x 34 x 4	4
32	055A-576	SPROCKET SUPPORT	4
33		ALLEN HEAD SCREW M10X20	8
34		ALLEN BUTTON HEAD SCREW M5X10	12
35		ALLEN SCREW M8X20	4
36		DOWEL PIN DIA 1/8"X58" LONG	4
37		ROLLER CHAIN	1
38	055A-556	SPROCKET	4
39	055A-564	TOP PLATE	4
40		ALLEN BUTTON HEAD SCREW M5X6	4
41	055A-557	TENSION SPRING	4
42	055A-565	BUSH	12
43		ALLEN HEAD GRUB SCREW M6x10	1
44	055A-623	TENON	4
45		ALLEN SCREW M5X12	4
46	055A-619	T-NUT	4
47	055A-679	CRADLE RIGHT	1
48		HEX NUT M10	1
49	055A-519	PIVOT	1
50		ALLEN GRUB SCREW M5x6	1
51	055A-882	HAND WHEEL	1
52	055A-885	SPACER	1
53		ALLEN HEAD SCREW M12X40	4

S. NO.	PART NO.	DESCRIPTION	QTY. SG-80A, SG-80M & SG-80MTS
54	055A-880	RING NUT	1
55	055A-878	ARM	1
56	055A-634	ADJUSTER	1
57		SPRING DOWEL PIN DIA 1/8"X5/8" LONG	1
58		PARALLEL KEY 1/8"x1/8"x5/8"LONG	1
59		ALLEN HEAD GRUB SCREW M6x6	1
60	055A-879	PIVOT ROD	1
61		NEEDLE THRUST BEARING 17x30x4	2
62	055A-654	PARALLEL BAR	2
63		ALLEN SCREW M12X55	8
64	055A-590	END STOPPER	4
65		ALLEN SCREW M6X12	8
66	055A-675	GUIDE ROD	2
67	055A-560	END COVER	4
68		ALLEN SCREW M8X16	4
69	055A-595	HANDLE BLOCK	2
70		ALLEN SCREW M8X16	4
71	---	-----	-----
72	055A-626	PLUG	4
73	055A-658	HOLDER SHAFT RIGHT	1
74		ALLEN SCREW M10X20	4
75	055A-670	T-BOLT	2
76	055A-659	HOLDER SHAFT LEFT	1
77		ALLEN SCREW M10X20	4
78	055A-669	T-BOLT	2
79	055A-674	SET-SCREW	4
80		STEEL BALL DIA 6MM	4
81		HEX NUT M8	4
82		ALLEN HEAD SCREW M8X90	4
83		HEX NUT M12	2
84	055A-323	SPHERICAL WASHER	4
85	055A-324	SPHERICAL WASHER	4
86		WASHER M8	8
87	282580	COMP. SPRING	4
88	055A-625	CHAIN BLOCK-B	2
89	055A-567	PIN	12
90	055A-635	PIVOT	2
91	055A-672	PIVOT	4
92	055A-645	VALVE PLATE	2
93		ALLEN CSK SCREW M6X12	4
94	055A-673	CYLINDER EXTENSION	2
95		PNEUMATIC CYLINDER	2
96		ALLEN HEAD SCREW M8X75	8
97	055A-682	JACK SCREW	1
98	055A-683	JACK COLLAR	1
99		CYLINDRICAL PIN DIA 1/8"X1-1/2" LONG	1
100	055A-681	JACK TOP	1
101	055A-680	JACK BASE	1
102		ALLEN GRUB SCREW M6X6	4
103	055A-661	PLUG	2
104	055A-883	COLLER	1
105	055A-884	LOCKING SPACER	1
106	055A-718	CRADLE COVER	2
107		ALLEN BUTTON HEAD SCREW M5X10	6



<b>S. NO.</b>	<b>PART NO.</b>	<b>DESCRIPTION</b>	<b>QTY. SG-80A, SG-80M &amp; SG-80MTS</b>
108	055A-694	CRADLE HOLDER (RIGHT)	1
109	055A-695	ZERO MARK	1
110		ALLEN HEAD CAP SCREW M6X16	2
111	055A-886	WASHER	4
112	055A-881	SHAFT EXTENSION	1
113		ALLEN GRUB SCREW M5x6	2
114		ALLEN HEAD SCREW M12x16	2
115		ALLEN GRUB SCREW M6x10	2
116	055A-639	SHAFT EXTENSION	2
117		PARALLEL KEY 3/16"x3/16"x1/2	2
118	055A-640	RING NUT	2
119	055A-654-S	PARALLEL BAR SCALE	1 SET
120	055A-606	HEIGHT BLOCK	2
121	055A-668	SET SCREW	2
122		NEEDLE BEARING NK 40/20	4
<b>123</b>	<b>055A-646</b>	<b>CLAMPING PIN</b>	<b>4</b>
<b>124</b>	<b>055A-648</b>	<b>CLAMP PLATE</b>	<b>2</b>
<b>125</b>	<b>055A-684</b>	<b>JACK SCREW LARGE</b>	<b>1</b>

Pneumatic Circuit Diagram New Design

SG-80A, SG-80M & SG-80MTS  
PNEUMATIC CIRCUIT DIAGRAM (M)

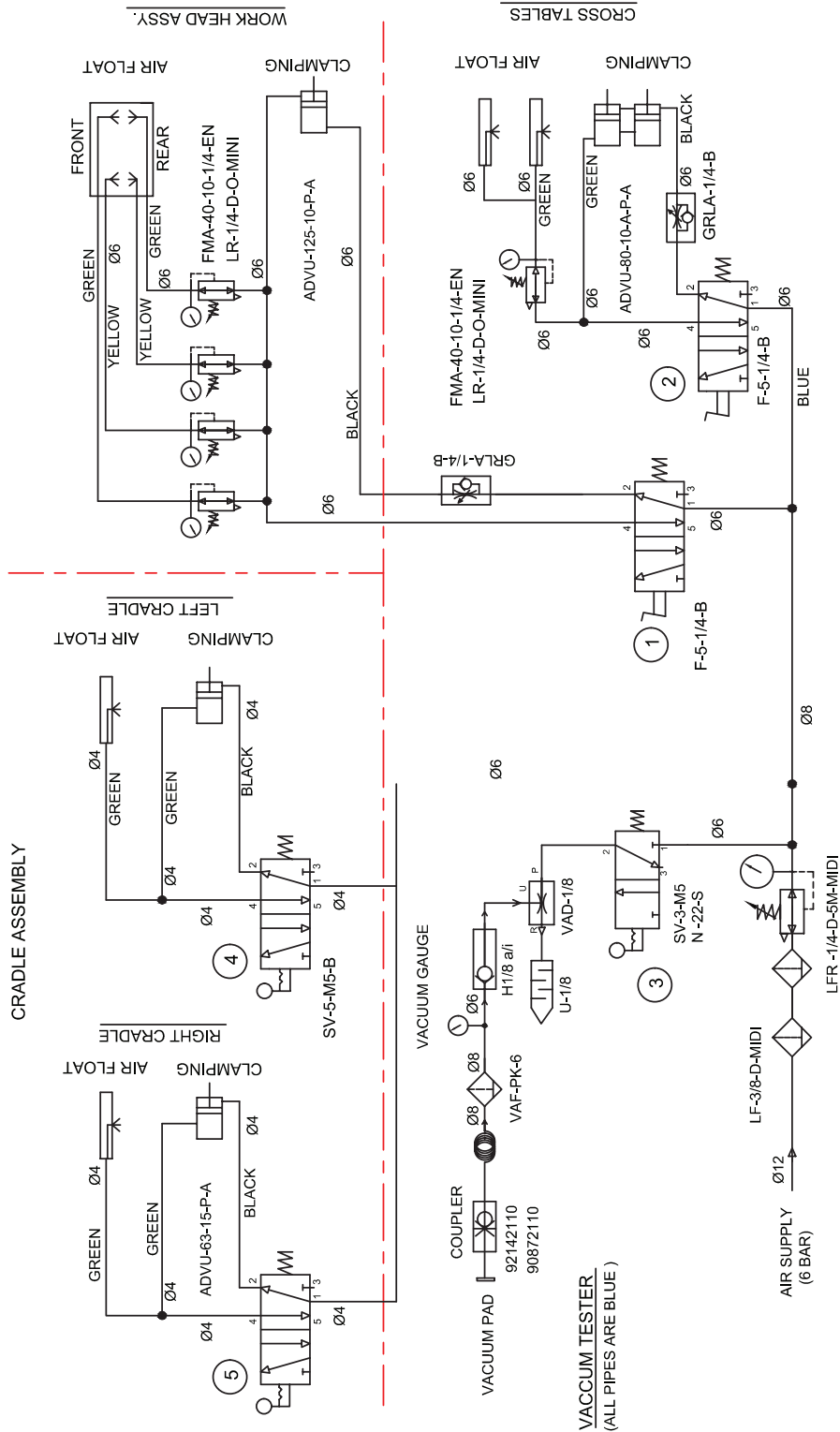

NOTE:

- ① FOOT PEDAL FOR WORK HEAD AIR FLOAT & CLAMP (SG-80M)
- ② FOOT PEDAL FOR CROSS TABLE AIR FLOAT & CLAMP
- ③ SELECTOR SWITCH FOR VACUUM TESTER
- ④ SELECTOR SWITCH FOR LEFT CRADLE AIR FLOAT & CLAMP
- ⑤ SELECTOR SWITCH FOR RIGHT CRADLE AIR FLOAT & CLAMP

### SG80M Electrical Drawing

A scalable copy is located on the manual CD.

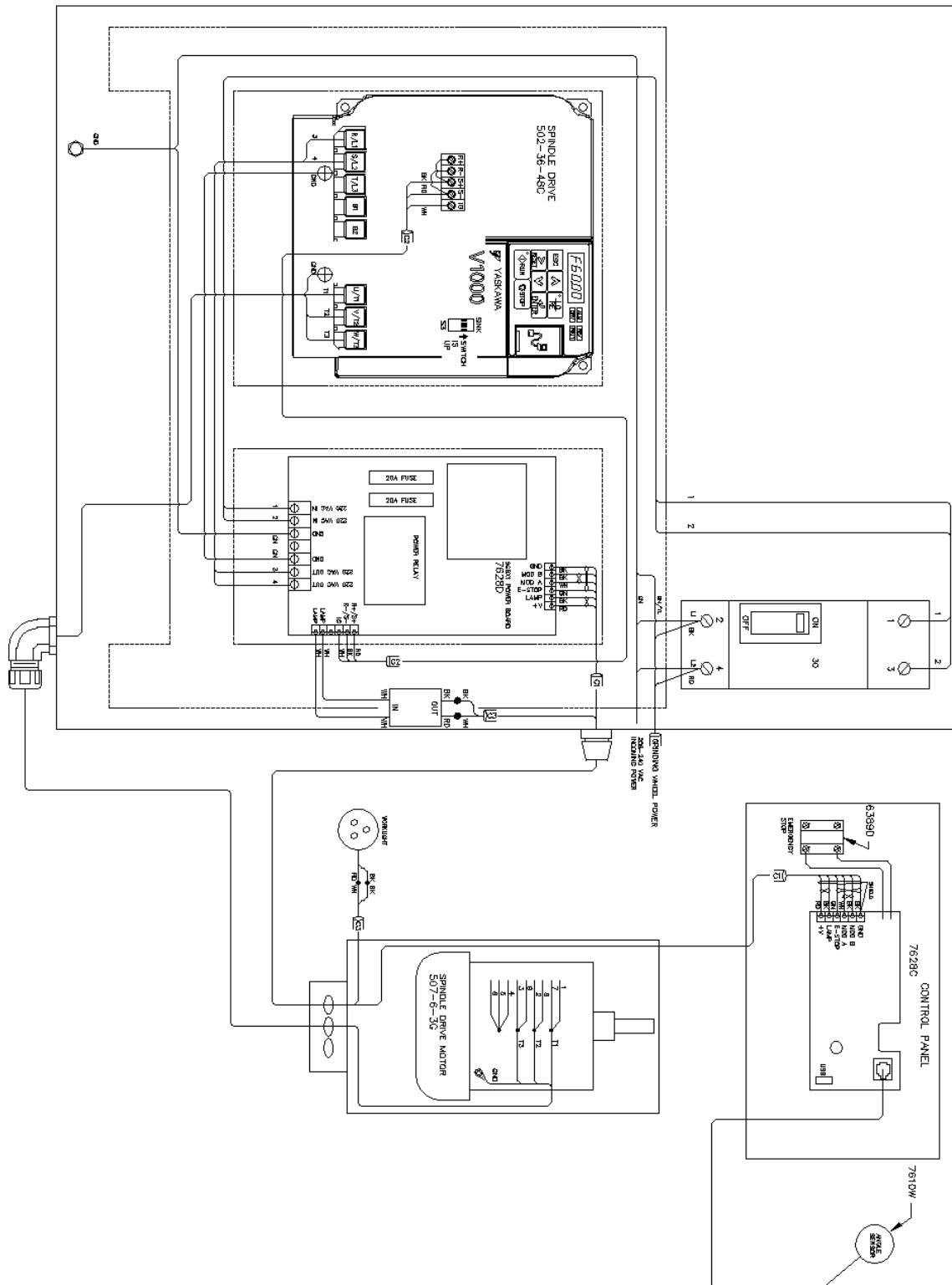

This page intentionally left blank

# OPTIONS

## Optional Equipment

Optional Equipment Catalog and Parts Manual are located on the Manual CD shipped with machine.

This page intentionally left blank



# MSDS

The Material Data Safety Sheets list shown in this section are the substances and materials that an operator is most likely to come in contact with while using this machine.

Other substances and materials are used in the manufacture, testing, and shipping of this machine. A complete list of the Material Data Safety Sheets of substances and materials used by Rottler Manufacturing during manufacturing, testing, and shipping is located on the Manual CD shipped with the machine. Material Data Safety Sheets are also located on the company web site: <http://www.rottlermfg.com/documentation.php>

**1) 76 Multi-Way Oil**

**2) 76 Unoba EP Grease**

# Safety Data Sheet



## Section 1: Identification of the substance or mixture and of the supplier

<b>Product Name:</b>	<b>Multi-Way Oil HD</b>
<b>SDS Number:</b>	817776
<b>Synonyms/Other Means of Identification:</b>	Multi-Way HD 32 Multi-Way HD 68 Multi-Way HD 220
<b>Intended Use:</b>	Way Oil
<b>Manufacturer:</b>	Phillips 66 Lubricants 600 N. Dairy Ashford, 2WL9072F Houston, Texas 77079-1175
<b>Emergency Health and Safety Number:</b>	Chemtrec: 800-424-9300 (24 Hours)
<b>Customer Service:</b>	U.S.: 1-800-822-6457 or International: +1-83-2486-3363
<b>Technical Information:</b>	1-877-445-9198
<b>SDS Information:</b>	Phone: 800-762-0942 Email: SDS@P66.com URL: www.Phillips66.com

## Section 2: Hazard(s) Identification

This material is not considered hazardous according to OSHA criteria.



## Section 3: Composition / Information on Ingredients

Component	CASRN	Concentration <sup>1</sup>
Lubricant Base Oil (Petroleum)	VARIOUS	>95
Additives	Proprietary	<5

<sup>1</sup>All concentrations are percent by weight unless ingredient is a gas. Gas concentrations are in percent by volume.

## Section 4: First Aid Measures

**Eye Contact:** If irritation or redness develops from exposure, flush eyes with clean water. If symptoms persist, seek medical attention.

**Skin Contact:** Remove contaminated shoes and clothing and cleanse affected area(s) thoroughly by washing with mild soap and water or a waterless hand cleaner. If irritation or redness develops and persists, seek medical attention.

**Inhalation (Breathing):** First aid is not normally required. If breathing difficulties develop, move victim away from source of exposure and into fresh air in a position comfortable for breathing. Seek immediate medical attention.

**Ingestion (Swallowing):** First aid is not normally required; however, if swallowed and symptoms develop, seek medical attention.

817776 - Multi-Way Oil HD  
Date of Issue: 14-Jun-2012

Page 17  
Status: FINAL

817776 - Multi-Way Oil HD  
Date of Issue: 14-Jun-2012

Page 2/7  
Status: FINAL

**Notes to Physician:** Acute aspirations of large amounts of oil-laden material may produce a serious aspiration pneumonia. Patients who aspirate these oils should be followed for the development of long-term sequelae. Inhalation exposure to oil mists below current workplace exposure limits is unlikely to cause pulmonary abnormalities.

**Medical Conditions Aggravated by Exposure:** Conditions which may be aggravated by exposure include skin disorders.

### Section 5: Fire-Fighting Measures

#### NFPA 704 Hazard Class

Health: 0 Flammability: 1 Instability: 0 (0-Minimal, 1-Slight, 2-Moderate, 3-Serious, 4-Severe)

**Unusual Fire & Explosion Hazards:** This material may burn, but will not ignite readily. If container is not properly cooled, it can rupture in the heat of a fire.

**Extinguishing Media:** Dry chemical, carbon dioxide, foam, or water spray is recommended. Water or foam may cause frothing of materials heated above 212°F / 100°C. Carbon dioxide can displace oxygen. Use caution when applying carbon dioxide in confined spaces. Simultaneous use of foam and water on the same surface is to be avoided as water destroys the foam.

**Fire Fighting Instructions:** For fires beyond the initial stage, emergency responders in the immediate hazard area should wear protective clothing. When the potential chemical hazard is unknown, in enclosed or confined spaces, a self contained breathing apparatus should be worn. In addition, wear other appropriate protective equipment as conditions warrant (see Section 8).

Isolate immediate hazard area and keep unauthorized personnel out. Stop spill/release if it can be done safely. Move undamaged containers from immediate hazard area if it can be done safely. Water spray may be useful in minimizing or dispersing vapors and to protect personnel. Cool equipment exposed to fire with water, if it can be done safely. Avoid spreading burning liquid with water used for cooling purposes.

**Hazardous Combustion Products:** Combustion may yield smoke, carbon monoxide, and other products of incomplete combustion. Oxides of sulfur, nitrogen or phosphorus may also be formed.

See Section 9 for Flammable Properties including Flash Point and Flammable (Explosive) Limits

### Section 6: Accidental Release Measures

**Personal Precautions:** This material may burn, but will not ignite readily. Keep all sources of ignition away from spill/release. Stay upwind and away from spill/release. Avoid direct contact with material. For large spillages, notify persons down wind of the spill/release, isolate immediate hazard area and keep unauthorized personnel out. Wear appropriate protective equipment, including respiratory protection, as conditions warrant (see Section 8). See Sections 2 and 7 for additional information on hazards and precautionary measures.

**Environmental Precautions:** Stop spill/release if it can be done safely. Prevent spilled material from entering sewers, storm drains, other unauthorized drainage systems, and natural waterways. Use water sparingly to minimize environmental contamination and reduce disposal requirements. If spill occurs on water notify appropriate authorities and advise shipping of any hazard. Spills into or upon navigable waters, the contiguous zone, or adjoining shorelines that cause a sheen or discoloration on the surface of the water, may require notification of the National Response Center (phone number 800-424-8802). If spill/release in excess of EPA reportable quantity (see Section 15) is made into the environment, immediately notify the National Response Center (phone number 800-424-8802).

**Methods for Containment and Clean-Up:** Notify relevant authorities in accordance with all applicable regulations. Immediate cleanup of any spill is recommended. Dike far ahead of spill for later recovery or disposal. Absorb spill with inert material such as sand or vermiculite, and place in suitable container for disposal. If spilled on water remove with appropriate methods (e.g. skimming, booms or absorbents). In case of soil contamination, remove contaminated soil for remediation or disposal, in accordance with local regulations.

Recommended measures are based on the most likely spillage scenarios for this material; however local conditions and regulations may influence or limit the choice of appropriate actions to be taken. See Section 13 for information on appropriate disposal.

### Section 7: Handling and Storage

**Precautions for safe handling:** Keep away from flames and hot surfaces. Wash thoroughly after handling. Use good personal hygiene practices and wear appropriate personal protective equipment (see section 8).

817776 - Multi-Way Oil HD  
Date of Issue: 14-Jun-2012

Page 3/7  
Status: FINAL

Spills will produce extremely slippery surfaces. Do not enter confined spaces such as tanks or pits without following proper entry procedures such as ASTM D-4276 and 29CFR 1910.146. Do not wear contaminated clothing or shoes.

**Conditions for safe storage:** Keep container(s) tightly closed and properly labeled. Use and store this material in cool, dry, well-ventilated area away from heat and all sources of ignition. Store only in approved containers. Keep away from any incompatible material (see Section 10). Protect container(s) against physical damage.

"Empty" containers retain residue and may be dangerous. Do not pressurize, cut, weld, braze, solder, drill, grind, or expose such containers to heat, flame, sparks, or other sources of ignition. They may explode and cause injury or death. "Empty" drums should be completely drained, properly bunged, and promptly shipped to the supplier or a drum reconditioner. All containers should be disposed of in an environmentally safe manner and in accordance with governmental regulations. Before working on or in tanks which contain or have contained this material, refer to OSHA regulations, ANSI Z49.1, and other references pertaining to cleaning, repairing, welding, or other contemplated operations.

### Section 8: Exposure Controls / Personal Protection

Component	ACGIH	OSHA	Other
Lubricant Base Oil (Petroleum)	TWA: 5mg/m <sup>3</sup> STEL: 10 mg/m <sup>3</sup> as oil mist, if generated	TWA: 5 mg/m <sup>3</sup> as Oil Mist, if generated	---

**Note:** State, local or other agencies or advisory groups may have established more stringent limits. Consult an industrial hygienist or similar professional, or your local agencies, for further information.

**Engineering controls:** If current ventilation practices are not adequate to maintain airborne concentrations below the established exposure limits, additional engineering controls may be required.

**Eye/Face Protection:** The use of eye/face protection is not normally required; however, good industrial hygiene practice suggests the use of eye protection that meets or exceeds ANSI Z.87.1 whenever working with chemicals.

**Skin/Hand Protection:** The use of skin protection is not normally required; however, good industrial hygiene practice suggests the use of gloves or other appropriate skin protection whenever working with chemicals. Suggested protective materials: Nitrile

**Respiratory Protection:** Where there is potential for airborne exposure above the exposure limit a NIOSH certified air purifying respirator equipped with R or P95 filters may be used.

A respiratory protection program that meets or is equivalent to OSHA 29 CFR 1910.134 and ANSI Z88.2 should be followed whenever workplace conditions warrant a respirator's use. Air purifying respirators provide limited protection and cannot be used in atmospheres that exceed the maximum use concentration (as directed by regulation or the manufacturer's instructions), in oxygen deficient (less than 19.5 percent oxygen) situations, or under conditions that are immediately dangerous to life and health (IDLH).

Suggestions provided in this section for exposure control and specific types of protective equipment are based on readily available information. Users should consult with the specific manufacturer to confirm the performance of their protective equipment. Specific situations may require consultation with industrial hygiene, safety, or engineering professionals.

### Section 9: Physical and Chemical Properties

**Note:** Unless otherwise stated, values are determined at 20°C (68°F) and 760 mm Hg (1 atm). Data represent typical values and are not intended to be specifications.

<b>Appearance:</b>	Dark amber
<b>Physical Form:</b>	Liquid
<b>Odor:</b>	Petroleum
<b>Odor Threshold:</b>	No data
<b>pH:</b>	Not applicable
<b>Vapor Pressure:</b>	<1 mm Hg
<b>Vapor Density (air=1):</b>	>1
<b>Initial Boiling Point/Range:</b>	No data
<b>Melting/Freezing Point:</b>	No data
<b>Pour Point:</b>	< 5 °F / < -15 °C
<b>Solubility in Water:</b>	Insoluble
<b>Partition Coefficient (n-octanol/water) (Kow):</b>	No data

817776 - Multi-Way Oil HD  
Date of Issue: 14-Jun-2012

Page 4/7  
Status: FINAL

Specific Gravity (water=1):	0.865 - 0.884 @ 60°F (15.6°C)
Bulk Density:	7.20 - 7.37 lbs/gal
Viscosity:	5 - 20 cSt @ 100°C; 32 - 220 cSt @ 40°C
Evaporation Rate (nBuAc=1):	No data
Flash Point:	> 320 °F / > 160 °C
Test Method:	Pensky-Martens Closed Cup (PMCC), ASTM D93, EPA 1010
Lower Explosive Limits (vol % in air):	No data
Upper Explosive Limits (vol % in air):	No data
Auto-ignition Temperature:	No data

## Section 10: Stability and Reactivity

**Stability:** Stable under normal ambient and anticipated conditions of use.

**Conditions to Avoid:** Extended exposure to high temperatures can cause decomposition. Avoid all possible sources of ignition.

**Materials to Avoid (Incompatible Materials):** Avoid contact with strong oxidizing agents and strong reducing agents.

**Hazardous Decomposition Products:** Not anticipated under normal conditions of use.

**Hazardous Polymerization:** Not known to occur.

## Section 11: Toxicological Information

Information on Toxicological Effects of Substance/Mixture

Acute Toxicity	Hazard	Additional Information	LC50/LD50 Data
Inhalation	Unlikely to be harmful		>5 mg/L (mist, estimated)
Skin Absorption	Unlikely to be harmful		> 2 g/kg (estimated)
Ingestion (Swallowing)	Unlikely to be harmful		> 5 g/kg (estimated)

**Aspiration Hazard:** Not expected to be an aspiration hazard.

**Skin Corrosion/Irritation:** Not expected to be irritating. Repeated exposure may cause skin dryness or cracking.

**Serious Eye Damage/Irritation:** Not expected to be irritating.

**Signs and Symptoms:** Inhalation of oil mists or vapors generated at elevated temperatures may cause respiratory irritation. Accidental ingestion can result in minor irritation of the digestive tract, nausea and diarrhea.

**Skin Sensitization:** Not expected to be a skin sensitizer.

**Respiratory Sensitization:** No information available.

**Specific Target Organ Toxicity (Single Exposure):** No information available on the mixture, however none of the components have been classified for target organ toxicity (or are below the concentration threshold for classification).

**Specific Target Organ Toxicity (Repeated Exposure):** No information available on the mixture, however none of the components have been classified for target organ toxicity (or are below the concentration threshold for classification).

**Carcinogenicity:** No information available on the mixture, however none of the components have been classified for carcinogenicity (or are below the concentration threshold for classification). A mortality study sponsored by General Motors and the United Auto Workers suggested a link between cutting oils or machining fluids and various forms of cancer (e.g., esophageal, laryngeal, and rectal). The study evaluated workplace exposures from 1940-1984. Since the composition of these materials has changed substantially since 1940, and because the most notable effects were seen among those with work histories dating back to that time, the relevance of these findings to present-day exposures is uncertain. Cutting oils or machining fluids have not been identified as carcinogens by NTP, IARC, or OSHA.

**Germ Cell Mutagenicity:** No information available on the mixture, however none of the components have been classified for germ cell mutagenicity (or are below the concentration threshold for classification).

817776 - Multi-Way Oil HD  
Date of Issue: 14-Jun-2012

Page 5/7  
Status: FINAL

**Reproductive Toxicity:** No information available on the mixture, however none of the components have been classified for reproductive toxicity (or are below the concentration threshold for classification).

#### Information on Toxicological Effects of Components

##### Lubricant Base Oil (Petroleum)

**Carcinogenicity:** The petroleum base oils contained in this product have been highly refined by a variety of processes including severe hydrocracking/hydroprocessing to reduce aromatics and improve performance characteristics. All of the oils meet the IP-346 criteria of less than 3 percent PAH's and are not considered carcinogens by NTP, IARC, or OSHA.

### Section 12: Ecological Information

**Toxicity:** All acute aquatic toxicity studies on samples of lubricant base oils show acute toxicity values greater than 100 mg/L for invertebrates, algae and fish. These tests were carried out on water accommodated fractions and the results are consistent with the predicted aquatic toxicity of these substances based on their hydrocarbon compositions. Classification: No classified hazards.

**Persistence and Degradability:** The hydrocarbons in this material are not readily biodegradable, but since they can be degraded by microorganisms, they are regarded as inherently biodegradable.

**Bioaccumulative Potential:** Log Kow values measured for the hydrocarbon components of this material are greater than 5.3, and therefore regarded as having the potential to bioaccumulate. In practice, metabolic processes may reduce bioconcentration.

**Mobility in Soil:** Volatilization to air is not expected to be a significant fate process due to the low vapor pressure of this material. In water, base oils will float and spread over the surface at a rate dependent upon viscosity. There will be significant removal of hydrocarbons from the water by sediment adsorption. In soil and sediment, hydrocarbon components will show low mobility with adsorption to sediments being the predominant physical process. The main fate process is expected to be slow biodegradation of the hydrocarbon constituents in soil and sediment.

**Other Adverse Effects:** None anticipated.

### Section 13: Disposal Considerations

The generator of a waste is always responsible for making proper hazardous waste determinations and needs to consider state and local requirements in addition to federal regulations.

This material, if discarded as produced, would not be a federally regulated RCRA "listed" hazardous waste and is not believed to exhibit characteristics of hazardous waste. See Sections 7 and 8 for information on handling, storage and personal protection and Section 9 for physical/chemical properties. It is possible that the material as produced contains constituents which are not required to be listed in the MSDS but could affect the hazardous waste determination. Additionally, use which results in chemical or physical change of this material could subject it to regulation as a hazardous waste.

This material under most intended uses would become "Used Oil" due to contamination by physical or chemical impurities. Whenever possible, Recycle used oil in accordance with applicable federal and state or local regulations. Container contents should be completely used and containers should be emptied prior to discard.

### Section 14: Transport Information

#### U.S. Department of Transportation (DOT)

Shipping Description: *Not regulated*  
Note: *If shipped by land in a packaging having a capacity of 3,500 gallons or more, the provisions of 49 CFR, Part 130 apply. (Contains oil)*

#### International Maritime Dangerous Goods (IMDG)

Shipping Description: *Not regulated*  
Note: *U.S. DOT compliance requirements may apply. See 49 CFR 171.22, 23 & 25.*

#### International Civil Aviation Org. / International Air Transport Assoc. (ICAO/IATA)

UN/ID #: *Not regulated*  
Note: *U.S. DOT compliance requirements may apply. See 49 CFR 171.22, 23 & 24.*

	LTD. QTY	Passenger Aircraft	Cargo Aircraft Only
Packaging Instruction #:	---	---	---
Max. Net Qty. Per Package:	---	---	---



817776 - Multi-Way Oil HD  
Date of Issue: 14-Jun-2012

Page 6/7  
Status: FINAL

### Section 15: Regulatory Information

#### CERCLA/SARA - Section 302 Extremely Hazardous Substances and TPQs (in pounds):

This material does not contain any chemicals subject to the reporting requirements of SARA 302 and 40 CFR 372.

#### CERCLA/SARA - Section 311/312 (Title III Hazard Categories)

Acute Health:	No
Chronic Health:	No
Fire Hazard:	No
Pressure Hazard:	No
Reactive Hazard:	No

#### CERCLA/SARA - Section 313 and 40 CFR 372:

This material does not contain any chemicals subject to the reporting requirements of SARA 313 and 40 CFR 372.

#### EPA (CERCLA) Reportable Quantity (in pounds):

This material does not contain any chemicals with CERCLA Reportable Quantities. This material contains the following chemicals subject to the reporting requirements of 40 CFR 302.4:

#### California Proposition 65:

This material does not contain any chemicals which are known to the State of California to cause cancer, birth defects or other reproductive harm at concentrations that trigger the warning requirements of California Proposition 65.

#### International Hazard Classification

**GHS Classification**  
None

**Canada:**  
This product has been classified in accordance with the hazard criteria of the Controlled Products Regulations (CPR) and the MSDS contains all the information required by the Regulations.

**WHMIS Hazard Class:**  
None

#### National Chemical Inventories

All components are either listed on the US TSCA Inventory, or are not regulated under TSCA  
All components are either on the DSL, or are exempt from DSL listing requirements

**U.S. Export Control Classification Number:** EAR99

### Section 16: Other Information

<b>Date of Issue:</b>	14-Jun-2012
<b>Status:</b>	FINAL
<b>Previous Issue Date:</b>	04-Aug-2011
<b>Revised Sections or Basis for Revision:</b>	Format change Manufacturer (Section 1) Toxicological (Section 11) Regulatory information (Section 15)
<b>SDS Number:</b>	817776

#### Guide to Abbreviations:

ACGIH = American Conference of Governmental Industrial Hygienists; CASRN = Chemical Abstracts Service Registry Number; CEILING = Ceiling Limit (15 minutes); CERCLA = The Comprehensive Environmental Response, Compensation, and Liability Act; EPA = Environmental Protection Agency; GHS = Globally Harmonized System; IARC = International Agency for Research on Cancer; INSHT = National Institute for Health and Safety at Work; IOPC = International Oil Pollution Compensation; LEL = Lower Explosive Limit; NE = Not Established; NFPA = National Fire Protection Association; NTP = National Toxicology Program; OSHA = Occupational Safety and Health Administration; PEL = Permissible Exposure Limit (OSHA); SARA = Superfund Amendments and Reauthorization Act; STEL = Short Term Exposure Limit (15 minutes); TLV = Threshold Limit Value (ACGIH); TWA = Time Weighted Average (8 hours); UEL = Upper Explosive Limit; WHMIS = Worker Hazardous Materials Information System (Canada)

817776 - Multi-Way Oil HD  
Date of Issue: 14-Jun-2012

Page 717  
Status: FINAL

---

**Disclaimer of Expressed and implied Warranties:**

The information presented in this Material Safety Data Sheet is based on data believed to be accurate as of the date this Material Safety Data Sheet was prepared. HOWEVER, NO WARRANTY OF MERCHANTABILITY, FITNESS FOR ANY PARTICULAR PURPOSE, OR ANY OTHER WARRANTY IS EXPRESSED OR IS TO BE IMPLIED REGARDING THE ACCURACY OR COMPLETENESS OF THE INFORMATION PROVIDED ABOVE, THE RESULTS TO BE OBTAINED FROM THE USE OF THIS INFORMATION OR THE PRODUCT, THE SAFETY OF THIS PRODUCT, OR THE HAZARDS RELATED TO ITS USE. No responsibility is assumed for any damage or injury resulting from abnormal use or from any failure to adhere to recommended practices. The information provided above, and the product, are furnished on the condition that the person receiving them shall make their own determination as to the suitability of the product for their particular purpose and on the condition that they assume the risk of their use. In addition, no authorization is given nor implied to practice any patented invention without a license.



## Unoba® EP Grease (All Grades)

### Material Safety Data Sheet

#### 1. Product and Company Identification

Product Name:	Unoba® EP Grease (All Grades)
MSDS Number:	722490
Synonyms:	76 Unoba® EP Grease 00 76 Unoba® EP Grease 0 76 Unoba® EP Grease 1 76 Unoba® EP Grease 2 76 Unoba® EP Grease 3
Intended Use:	Lubricating Grease
Manufacturer/Supplier:	ConocoPhillips Lubricants 600 N. Dairy Ashford, 2W900 Houston, Texas 77079-1175
Emergency Health and Safety Number:	Chemtrec: 800-424-9300 (24 Hours)
Customer Service:	U.S.: 888-766-7676 or International: +1-83-2486-3363
Technical Information:	800-435-7761
MSDS Information:	Internet: <a href="http://w3.conocophillips.com/NetMSDS/">http://w3.conocophillips.com/NetMSDS/</a>

#### 2. Hazards Identification

<u>Emergency Overview</u>	<u>NFPA</u>
<p><b>CAUTION!</b></p> <p>Eye Irritant</p>	

**Appearance:** Green  
**Physical Form:** Semi-Solid  
**Odor:** Petroleum

#### Potential Health Effects

**Eye:** Eye irritant. Contact may cause stinging, watering, redness, and swelling.

**Skin:** Contact may cause mild skin irritation including redness and a burning sensation. Prolonged or repeated contact can defat the skin, causing drying and cracking of the skin, and possibly dermatitis (inflammation). No harmful effects from skin absorption are expected.

**Inhalation (Breathing):** No information available on acute toxicity.

**Ingestion (Swallowing):** No harmful effects expected from ingestion.

**Signs and Symptoms:** Effects of overexposure may include irritation of the digestive tract, nausea and diarrhea. Inhalation of oil mist or vapors at elevated temperatures may cause respiratory irritation.

**Pre-Existing Medical Conditions:** Conditions which may be aggravated by exposure include skin disorders and eye disorders.

722490 - Unoba® EP Grease (All Grades)  
 Date of Issue:

Page 1/6  
 Status: Final

722490 - Unoba® EP Grease (All Grades)  
 Date of Issue: 23-Oct-2008

Page 2/6  
 Status: Final

See Section 11 for additional Toxicity Information.

### 3. Composition / Information on Ingredients

Component	CASRN	Concentration*
Lubricant Base Oil (Petroleum)	VARIOUS	<90
Additives	PROPRIETARY	>12
Zinc dialkyl dithiophosphate	68649-42-3	<2

\* All concentrations are percent by weight unless ingredient is a gas. Gas concentrations are in percent by volume.

### 4. First Aid Measures

**Eye Contact:** If irritation or redness develops from exposure, flush eyes with clean water. Remove contact lenses if present and easy to do. For direct contact, hold eyelids apart and flush the affected eye(s) with clean water for at least 15 minutes. If irritation persists, seek medical attention.

**Skin Contact:** Remove contaminated shoes and clothing and cleanse affected area(s) thoroughly by washing with mild soap and water or a waterless hand cleaner. If irritation or redness develops and persists, seek medical attention.

**Inhalation (Breathing):** If respiratory symptoms develop, move victim away from source of exposure and into fresh air in a position comfortable for breathing. If symptoms persist, seek medical attention.

**Ingestion (Swallowing):** First aid is not normally required; however, if swallowed and symptoms develop, seek medical attention.

**Notes to Physician:** High-pressure hydrocarbon injection injuries may produce substantial necrosis of underlying tissue despite an innocuous appearing external wound. Often these injuries require extensive emergency surgical debridement and all injuries should be evaluated by a specialist in order to assess the extent of injury.

### 5. Fire-Fighting Measures

#### NFPA 704 Hazard Class

Health: 1 Flammability: 1 Instability: 0 (0-Minimal, 1-Slight, 2-Moderate, 3-Serious, 4-Severe)

**Unusual Fire & Explosion Hazards:** This material may burn, but will not ignite readily. If container is not properly cooled, it can rupture in the heat of a fire.

**Extinguishing Media:** Dry chemical, carbon dioxide, foam, or water spray is recommended. Water or foam may cause frothing of materials heated above 212°F. Carbon dioxide can displace oxygen. Use caution when applying carbon dioxide in confined spaces.

**Fire Fighting Instructions:** For fires beyond the incipient stage, emergency responders in the immediate hazard area should wear protective clothing. When the potential chemical hazard is unknown, in enclosed or confined spaces, a self contained breathing apparatus should be worn. In addition, wear other appropriate protective equipment as conditions warrant (see Section 8).

Isolate immediate hazard area and keep unauthorized personnel out. Stop spill/release if it can be done safely. Move undamaged containers from immediate hazard area if it can be done safely. Water spray may be useful in minimizing or dispersing vapors and to protect personnel. Cool equipment exposed to fire with water, if it can be done safely. Avoid spreading burning liquid with water used for cooling purposes.

**Hazardous Combustion Products:** Combustion may yield smoke, carbon monoxide, and other products of incomplete combustion. Oxides of sulfur, nitrogen or phosphorus may also be formed.

See Section 9 for Flammable Properties including Flash Point and Flammable (Explosive) Limits

### 6. Accidental Release Measures

**Personal Precautions:** This material may burn, but will not ignite readily. Keep all sources of ignition away from spill/release. The use of explosion-proof electrical equipment is recommended. Stay upwind and away from spill/release. Notify persons down wind of the spill/release, isolate immediate hazard area and keep unauthorized personnel out. Wear appropriate protective equipment, including respiratory protection, as conditions warrant (see Section 8). See Sections 2 and 7 for additional information on hazards and precautionary measures.

722490 - Unoba® EP Grease (All Grades)  
 Date of Issue: 23-Oct-2008

Page 3/6  
 Status: Final

**Environmental Precautions:** Stop spill/release if it can be done safely. Prevent spilled material from entering sewers, storm drains, other unauthorized drainage systems, and natural waterways. Use water sparingly to minimize environmental contamination and reduce disposal requirements. Spills into or upon navigable waters, the contiguous zone, or adjoining shorelines that cause a sheen or discoloration on the surface of the water, may require notification of the National Response Center (phone number 800-424-8802).

**Methods for Containment and Clean-Up:** Notify relevant authorities in accordance with all applicable regulations. Immediate cleanup of any spill is recommended. Dike far ahead of spill for later recovery or disposal. Absorb spill with inert material such as sand or vermiculite, and place in suitable container for disposal.

## 7. Handling and Storage

**Precautions for safe handling:** Wear eye/face protection. Wash thoroughly after handling. Use good personal hygiene practices and wear appropriate personal protective equipment.

High pressure injection of hydrocarbon fuels, hydraulic oils or greases under the skin may have serious consequences even though no symptoms or injury may be apparent. This can happen accidentally when using high pressure equipment such as high pressure grease guns, fuel injection apparatus or from pinhole leaks in tubing of high pressure hydraulic oil equipment.

Do not enter confined spaces such as tanks or pits without following proper entry procedures such as ASTM D-4276 and 29CFR 1910.146. Do not wear contaminated clothing or shoes.

"Empty" containers retain residue and may be dangerous. Do not pressurize, cut, weld, braze, solder, drill, grind, or expose such containers to heat, flame, sparks, or other sources of ignition. They may explode and cause injury or death. "Empty" drums should be completely drained, properly bunged, and promptly shipped to the supplier or a drum reconditioner. All containers should be disposed of in an environmentally safe manner and in accordance with governmental regulations. Before working on or in tanks which contain or have contained this material, refer to OSHA regulations, ANSI Z49.1, and other references pertaining to cleaning, repairing, welding, or other contemplated operations.

**Conditions for safe storage:** Keep container(s) tightly closed. Use and store this material in cool, dry, well-ventilated area away from heat and all sources of ignition. Store only in approved containers. Keep away from any incompatible material (see Section 10). Protect container(s) against physical damage.

## 8. Exposure Controls / Personal Protection

Component	US-ACGIH	OSHA	Other
Lubricant Base Oil (Petroleum)	TWA: 5mg/m <sup>3</sup> STEL: 10 mg/m <sup>3</sup> as Oil Mist, if generated	TWA: 5 mg/m <sup>3</sup> as Oil Mist, if generated	---

**Note:** State, local or other agencies or advisory groups may have established more stringent limits. Consult an industrial hygienist or similar professional, or your local agencies, for further information.

**Engineering controls:** If current ventilation practices are not adequate to maintain airborne concentrations below the established exposure limits, additional engineering controls may be required.

**Eye/Face Protection:** The use of eye protection that meets or exceeds ANSI Z.87.1 is recommended to protect against potential eye contact, irritation, or injury. Depending on conditions of use, a face shield may be necessary.

**Skin/Hand Protection:** The use of gloves impervious to the specific material handled is advised to prevent skin contact. Users should check with manufacturers to confirm the breakthrough performance of their products. Suggested protective materials: Nitrile.

**Respiratory Protection:** Respiratory protection is not normally required under intended conditions of use. Emergencies or conditions that could result in significant airborne exposures may require the use of NIOSH approved respiratory protection. An industrial hygienist or other appropriate health and safety professional should be consulted for specific guidance under these situations.

**Suggestions provided in this section for exposure control and specific types of protective equipment are based on readily available information. Users should consult with the specific manufacturer to confirm the performance of their protective equipment. Specific situations may require consultation with industrial hygiene, safety, or engineering professionals.**

## 9. Physical and Chemical Properties

**Note:** Unless otherwise stated, values are determined at 20°C (68°F) and 760 mm Hg (1 atm). Data represent typical values and are not intended to be specifications.

722490 - Unoba® EP Grease (All Grades)  
Date of Issue: 23-Oct-2008

Page 4/6  
Status: Final

Appearance:	Green
Physical Form:	Semi-Solid
Odor:	Petroleum
Odor Threshold:	No data
pH:	Not applicable
Vapor Pressure:	<0.1mm Hg
Vapor Density (air=1):	> 5
Boiling Point/Range:	No data
Melting/Freezing Point:	No data
Solubility in Water:	Negligible
Partition Coefficient (n-octanol/water) (Kow):	No data
Bulk Density:	7.5 lbs/gal
Percent Volatile:	Negligible
Evaporation Rate (nBuAc=1):	<1
Flash Point:	450°F / 232°C
Test Method:	Cleveland Open Cup (COC), ASTM D92
LEL (vol % in air):	No data
UEL (vol % in air):	No data
Autoignition Temperature:	No data

## 10. Stability and Reactivity

**Stability:** Stable under normal ambient and anticipated conditions of use.

**Conditions to Avoid:** Extended exposure to high temperatures can cause decomposition.

**Materials to Avoid (Incompatible Materials):** Avoid contact with strong oxidizing agents and strong reducing agents.

**Hazardous Decomposition Products:** Not anticipated under normal conditions of use.

**Hazardous Polymerization:** Not known to occur.

## 11. Toxicological Information

### Chronic Data:

#### Lubricant Base Oil (Petroleum)

**Carcinogenicity:** The petroleum base oils contained in this product have been highly refined by a variety of processes including severe hydrocracking/hydroprocessing to reduce aromatics and improve performance characteristics. All of the oils meet the IP-346 criteria of less than 3 percent PAH's and are not considered carcinogens by NTP, IARC, or OSHA.

### Acute Data:

Component	Oral LD50	Dermal LD50	Inhalation LC50
Lubricant Base Oil (Petroleum)	>5 g/kg	>2 g/kg	No data
Zinc dialkyl dithiophosphate	>2000 mg/kg (rat)	>2000 mg/kg (rat)	No data

## 12. Ecological Information

**Ecotoxicity:** Experimental studies show that acute aquatic toxicity values are in the range 1-100 mg/l. These values are consistent with the predicted aquatic toxicity of these substances based on their hydrocarbon compositions. Should be regarded as capable of causing long term adverse effects in the aquatic environment.

**Mobility:** Volatilization to air is not expected to be a significant fate process due to the low vapor pressure of this material. Components may behave differently in the aquatic environment with soaps dispersing and dissolving to some extent in water while the hydrocarbons will float on the surface due to their low water solubility. The hydrocarbon portion would be expected to show low mobility in soil and water. The major environmental fate would be expected to be biodegradation.

**Persistence and degradability:** The base oil constituents of greases are expected to be inherently, but not readily biodegradable. Some of the thickening agents may be readily biodegradable.

**Bioaccumulation Potential:** Log Kow values measured for the hydrocarbon components of this material range from 4 to over 6, and therefore regarded as having the potential to bioaccumulate. In practice, metabolic processes may reduce bioconcentration.



722490 - Unoba® EP Grease (All Grades)  
 Date of Issue: 23-Oct-2008

Page 5/6  
 Status: Final

### 13. Disposal Considerations

The generator of a waste is always responsible for making proper hazardous waste determinations and needs to consider state and local requirements in addition to federal regulations.

This material, if discarded as produced, would not be a federally regulated RCRA "listed" hazardous waste and is not believed to exhibit characteristics of hazardous waste. See Sections 7 and 8 for information on handling, storage and personal protection and Section 9 for physical/chemical properties. It is possible that the material as produced contains constituents which are not required to be listed in the MSDS but could affect the hazardous waste determination. Additionally, use which results in chemical or physical change of this material could subject it to regulation as a hazardous waste.

This material under most intended uses would become "Used Oil" due to contamination by physical or chemical impurities. Whenever possible, Recycle Used Oil in accordance with applicable federal and state or local regulations. Container contents should be completely used and containers should be emptied prior to discard.

### 14. Transportation Information

#### U.S. Department of Transportation (DOT)

Shipping Description: *Not regulated*  
 Note: *If shipped by land in a packaging having a capacity of 3,500 gallons or more, the provisions of 49 CFR, Part 130 apply. (Contains oil)*

#### International Maritime Dangerous Goods (IMDG)

Shipping Description: *Not regulated*  
 Note: *U.S. DOT compliance requirements may apply. See 49 CFR 171.22, 23 & 25.*

#### International Civil Aviation Org. / International Air Transport Assoc. (ICAO/IATA)

UN/ID #: *Not regulated*

	LTD. QTY	Passenger Aircraft	Cargo Aircraft Only
Packaging Instruction #:	---	---	---
Max. Net Qty. Per Package:	---	---	---

### 15. Regulatory Information

#### CERCLA/SARA - Section 302 Extremely Hazardous Substances and TPQs (in pounds):

This material does not contain any chemicals subject to the reporting requirements of SARA 302 and 40 CFR 372.

#### CERCLA/SARA - Section 311/312 (Title III Hazard Categories)

Acute Health: Yes  
 Chronic Health: No  
 Fire Hazard: No  
 Pressure Hazard: No  
 Reactive Hazard: No

#### CERCLA/SARA - Section 313 and 40 CFR 372:

This material contains the following chemicals subject to the reporting requirements of Section 313 of SARA Title III and 40 CFR 372:

Component	Concentration*	de minimis
Zinc compound(s)	<2	1.0%

#### EPA (CERCLA) Reportable Quantity (in pounds):

This material does not contain any chemicals with CERCLA Reportable Quantities. This material contains the following chemicals subject to the reporting requirements of 40 CFR 302.4:

722490 - Unoba® EP Grease (All Grades)  
 Date of Issue: 23-Oct-2008

Page 6/6  
 Status: Final

**California Proposition 65:**

Warning: This material may contain detectable quantities of the following chemicals, known to the State of California to cause cancer, birth defects or other reproductive harm, and which may be subject to the requirements of California Proposition 65 (CA Health & Safety Code Section 25249.5):

Component	Type of Toxicity
Silica-Crystalline (Quartz)	Cancer
Naphthalene	Cancer

**Canadian Regulations:**

This product has been classified in accordance with the hazard criteria of the Controlled Products Regulations (CPR) and the MSDS contains all the information required by the Regulations.

WHMIS Hazard Class  
 D2B

**National Chemical Inventories:**

All components are either listed on the US TSCA Inventory, or are not regulated under TSCA.  
 All components are either on the DSL, or are exempt from DSL listing requirements.

U.S. Export Control Classification Number: EAR99

**16. Other Information**

Date of Issue: 23-Oct-2008  
 Status: Final  
 Previous Issue Date: 06-Apr-2005  
 Revised Sections or Basis for Revision: Emergency Overview (Section 2)  
 Health Hazard (Section 2)  
 Composition (Section 3)  
 Regulatory information (Section 15)  
 MSDS Number: 722490

**Guide to Abbreviations:**

ACGIH = American Conference of Governmental Industrial Hygienists; CASRN = Chemical Abstracts Service Registry Number; CEILING = Ceiling Limit (15 minutes); CERCLA = The Comprehensive Environmental Response, Compensation, and Liability Act; EPA = Environmental Protection Agency; IARC = International Agency for Research on Cancer; LEL = Lower Explosive Limit; NE = Not Established; NFPA = National Fire Protection Association; NTP = National Toxicology Program; OSHA = Occupational Safety and Health Administration; PEL = Permissible Exposure Limit (OSHA); SARA = Superfund Amendments and Reauthorization Act; STEL = Short Term Exposure Limit (15 minutes); TLV = Threshold Limit Value (ACGIH); TWA = Time Weighted Average (8 hours); UEL = Upper Explosive Limit; WHMIS = Worker Hazardous Materials Information System (Canada)

**Disclaimer of Expressed and implied Warranties:**

The information presented in this Material Safety Data Sheet is based on data believed to be accurate as of the date this Material Safety Data Sheet was prepared. HOWEVER, NO WARRANTY OF MERCHANTABILITY, FITNESS FOR ANY PARTICULAR PURPOSE, OR ANY OTHER WARRANTY IS EXPRESSED OR IS TO BE IMPLIED REGARDING THE ACCURACY OR COMPLETENESS OF THE INFORMATION PROVIDED ABOVE, THE RESULTS TO BE OBTAINED FROM THE USE OF THIS INFORMATION OR THE PRODUCT, THE SAFETY OF THIS PRODUCT, OR THE HAZARDS RELATED TO ITS USE. No responsibility is assumed for any damage or injury resulting from abnormal use or from any failure to adhere to recommended practices. The information provided above, and the product, are furnished on the condition that the person receiving them shall make their own determination as to the suitability of the product for their particular purpose and on the condition that they assume the risk of their use. In addition, no authorization is given nor implied to practice any patented invention without a license.