

November 11, 2003 Rev 0



SF7M & SF8M
MANUAL SURFACING MACHINES

MACHINE SERIAL NUMBER

OPERATIONS AND MAINTENANCE
MANUAL



MANUFACTURED BY:

ROTTLER MANUFACTURING COMPANY
8029 South 200th Street
Kent Washington 98032
USA

Phone: (253) 872-7050

Fax: (253) 395-0230

Website: <http://www.rottlermfg.com>

NOTE: WHEN ORDERING REPLACEMENT PARTS,
PLEASE GIVE THE MODEL AND SERIAL NUMBER.

ORDER BY PART NUMBER.
THERE IS A MINIMUM ORDER OF \$25.00

CHAPTER 1 INTRODUCTION / SAFETY / INSTALLATION:	1-1
Introduction:	1-1
Description:	1-1
Limited Warranty:	1-1
Safety Information:	1-2
Emergency Procedure:.....	1-3
Machine Installation:.....	1-3
Location:	1-3
Unpacking:.....	1-3
Shipping Hold Down Bolt:.....	1-3
Leveling:	1-4
Air Supply:	1-4
Power Supply	1-4
CHAPTER 2 CONTROL DEFINITIONS.....	2-1
CPU Control:	2-1
Master Power On/Off Switch:.....	2-1
Button Definition:	2-1
Emergency Stop:	2-2
Right:	2-2
Left:	2-2
Spindle Start:	2-2
Up/Dn Adjust:.....	2-2
Mill:	2-2
End of Cut Set Button:.....	2-2
Feed Rate:	2-2
Spindle RPM:.....	2-2
Cycle Start:	2-3
Surface Depth Dial Indicator:.....	2-3
CHAPTER 3 OPERATING INSTRUCTIONS:.....	3-1
Manual Operation:	3-2
Operation:	3-2
Cutting Inserts:.....	3-3
6303B	3-3
6303M	3-3
6303K	3-3
6303S	3-3
6303R.....	3-3
501-29-6E R2.....	3-4
6301J.....	3-4
6303P	3-4
6303Q.....	3-4
One Insert vs. Two Inserts:	3-4

General Information	3-5
Cutting Speed Calculation	3-5
CHAPTER 4 MAINTENANCE	4-1
Lubrication:.....	4-1
Ballscrew Nut:.....	4-1
Outer Spindle:.....	4-1
Inner Spindle:.....	4-1
Vertical Adjustment Nut:.....	4-1
Cleaning The Way Surface:.....	4-1
Spindle Lock Cylinder:.....	4-1
Lubrication – Quick Reference Chart:	4-2
SF7M -8A Machine Lubrication Illustration:	4-3
2 Axis Universal Machine Table 7119Q – Lubrication Illustration:.....	4-4
Setting Cutting Tool Inserts.....	4-5
Production Cutting	4-5
Aluminum & Cast Iron:	4-5
Dial Indicator Setting	4-6
Vertical Travel Chain Removal and Replacement:	4-7
Drive Belt Replacement:	4-8
Removal of Drive Sprocket:.....	4-9
Replacement of Drive Sprocket:	4-9
Driven Sprocket Removal and Replacement:	4-10
Removal of Driven Sprocket:	4-10
Replacement of Driven Sprocket:	4-10
Cutterhead and Chip Guard Removal:	4-11
Upper Housing Removal:.....	4-11
Upper Housing Removal:.....	4-12
Outer Spindle Removal:.....	4-13
Inner Spindle Removal:	4-14
Upper Spindle Bearing Removal:.....	4-14
Spindle Lock Removal:.....	4-15
Reassembly:	4-15
Spindle Sensor Adjustment:.....	4-16
Horizontal Ball Screw and Belt Alignment and Adjustment:	4-17
Air Adjustment of the SF7M – 8A Machine:	4-18
Up-Relief, Air Setting:.....	4-18

Up / Down Adjust, Air Setting:	4-18
Relief Valve, Setting:	4-18
Air Adjustments Illustration:	4-19
Pneumatic Control Diagram:	4-20
Cutterhead Tilt Adjustment:	4-21
Inner Spindle Adjustment:	4-22
CHAPTER 5 TROUBLESHOOTING:	5-1
CHAPTER 6 MACHINE PARTS:	6-1
Front / Right Side View SF8M:	6-1
Front / Right Side View SF7M:	6-2
Solenoid Assembly:	6-4
Electrical Enclosure:	6-5
Upper Housing:	6-6
Vertical Adjustment (Chain):	6-7
Spindle Base Front Section:	6-8
Inner / Outer Spindle Assembly:	6-9
Spindle Base Assembly:	6-10
Left Ballscrew Support:	6-11
Right Ballscrew Support:	6-12
Home and Limit Switches:	6-13
Pendant Assembly:	6-14
Spindle Base:	6-15
Chip Shield:	6-16
14" Fly Cutter:	6-17
Riser Set:	6-18

Chapter 1 Introduction / Safety / Installation:

Introduction:

This manual is divided into sections as listed in the table of contents.

It is required that the new user of the SF7M & SF8M read this manual, in particular the sections concerning safety, before operating the machine.

Description:

The model SF7M & SF8M surfacing machine is a precision, high speed surfacing unit.

The model SF7M & SF8M can be equipped with tooling and accessories for surfacing most American passenger car and truck, inline, 90 and 60 degree V-type blocks as well as cylinder heads.

SF7M & SF8M machines may be readily tooled to resurface a wide variety of engines, including European and Asian models, as well as perform various other surfacing operations.

This machine is designed for two purposes:

1. The alignment of the deck surface to the pan rails and main bearing locations, as have been done in the original factory surfacing.
2. A considerable savings in surfacing time and operator involvement as a result of fast block clamping, and convenient controls.

Change over or resetting time required to set up V-type or in-line engines is a minimum, making this machine highly suited to the jobber shop where engines cannot be run through, in model lots.

All feeds and rapid travels are power operated and controlled from the conveniently located control panel. Power required is 230 volt, single phase. This provides power to the variable speed AC motor controller, the horizontal S.C.R. drive, and various relays and solenoid valves that actuate mechanical controls on the machine to engage feeds and travels.

Limited Warranty:

Rottler Manufacturing Company Model SF8M parts and equipment is warranted as to materials and workmanship. This limited warranty remains in effect for one year from the date of delivery, provided the machine is owned and operated by the original purchaser and is operated and maintained as per the instructions in the manual.

Tools proven to be defective within the warranty period will be repaired or replaced at the factory's option.

We accept no responsibility for defects caused by external damage, wear, abuse, or misuse, nor do we accept any obligation to provide compensation for direct or indirect costs in connection with cases covered by the warranty.

Freight charges on warranty items (non-air shipment only) will be paid by Rottler Manufacturing for a period of 60 days only from the date of installation or set-up by a qualified service technician or sales representative.

Freight charges after the 60 day period are the customer's responsibility.

Safety Information:**▲ DANGER**

This machine is capable of causing severe bodily injury or death if EXTREME care is not used when operating!

The operator of the SF7M & SF8M should be a skilled machinist craftsman who is well versed in the caution, care, and knowledge required to safely operate metal cutting tools.

▲ WARNING

When boring the machine is capable of throwing metal chips over 10- feet from the cutting area. Always use the guards. Eye protection must be worn at all times by the operator and all other personnel in the area of the machine.

▲ CAUTION

The SF7M & SF8M operates under computerized control and, as is all computerized equipment, and is susceptible to extraneous electrical impulses internally for externally produced. The machine may make moves out of the operator control at any time. The operator should work in and around the machine with caution at all times.

The operator and nearby personnel should be familiar with the location and operation of the Emergency Stop Button.

Electrical Power:

Make sure all electrical equipment has the proper overload protection. The SF7M & SF8M should have a **fully isolated** power supply to prevent damage and uncontrolled movement of the machine. If the SF7M & SF8M is on the same power lines that are running to other electrical equipment (grinders, welders, and other AC motors) electrical noise can be induced into the SF7M & SF8M electrical system. Electrical noise can cause the controller to see false signals to move. Not supplying a fully isolated supply to the machine may void factory warranty. Refer to the Power supply section later in this chapter for voltage and amperage requirements of the.

Machine Operator:

The operator of the SF7M & SF8M should be a skilled machinist craftsman who is well versed in the caution, care, and knowledge required to safely operate metal cutting tools. **Eye protection must be worn at all times by the operator and all other personnel in the area of the machine.**

If the operator is not a skilled machinist he/she must pay strict attention to the Operating Instructions outlined in this manual, and get instruction from a qualified machinist in both production and operation of this machine.

The SF7M & SF8M machines have the following areas of exposed moving parts that you must train yourself to respect and stay away from when they are in motion:

Cutting Tool Area – Any operation involving hands in the cutter head area, such as inspection or alignment of the cutter head or tools, requires the power to be turned off.

Surfacing – Eye protection must be worn during this operation. Hands must be kept completely away from the cutter head. All chip guards must be kept in their normal operating position.

Operator Panel and Controls – Learn to identify and independently operate these controls by habit, while developing an awareness of keeping fingers and hands clear of moving machinery.

Machining – Eye protection must be worn during all operations of the machine. Hands must be kept completely away from the cutter head. All chip guards must be in position during machine operations.

Work Loading and Unloading – Carefully develop handling methods of loading and unloading work pieces so that no injury can result if hoist equipment or lift connection should fail. Periodically check lift components for damage that may cause failure of Block Handler Assembly. Lifting Eye can eventually fail if the eye is reset in line with the 502-1-80 lift channel. ***Eye must be at a right angle.***

Machine Maintenance – Any machine adjustment, maintenance or parts replacement absolutely requires a complete power disconnection from the machine, ***this is an absolute rule.***

Emergency Procedure:

Assuming one of the following has occurred: Work piece or spindle base not clamped, depth of cut not set correctly, these mistakes will become obvious the minute the cut starts

PRESS THE EMERGENCY STOP BUTTON (on the front control panel) IMMEDIATELY!

“REMEMBER” metal cutting tools have the speed and torque to severely injure any part of the human body exposed to them.

Machine Installation:

Location:

The productivity of this machine will depend a great deal on it's proper initial installation, particularly the means by which cylinder blocks/heads are lifted into the machine as well as the material handling to and from other operations in your shop.

The proper loading arrangement and location for your SF7M & SF8M machine is extremely important.

A slow travel (6 to 10 feet / min.) power hoist, operated from either a bridge crane or a jib crane arrangement works very well. A 1000-lb. hoist is generally adequate for lifting the engine block. An air hoist with speed control makes an ideal method for fast, convenient loading.

If some production surfacing with this machine is anticipated, and the cylinder blocks/heads are not directly loaded and unloaded from a conveyor, we recommend considerable attention be given to the crane so that it covers an adequate area to allow the operator to back up and remove cylinder blocks/heads without cluttering up his own area. If two machines are to be operated by one operator, we recommend that the open faces be placed at right angles to each other, with the machines about three feet apart.

Unpacking:

Use care in removing the crate from the SF7M & SF8M machine, do not use force on any part of the spindle unit.

Remove the tool box, parallels, and optional tooling, located at the lower portion of the machine and completely clean these articles, as well as the machine base pads and upper table, with solvent. Rust inhibitor is applied to the machine at the time of shipment, any of this inhibitor left on the machine will result in considerable collecting of cast iron dirt.

Shipping Hold Down Bolt:

Remove cover (#7036E) from the rear of the spindle base by removing it's four mounting screws. Remove the bolt located in the front bottom of the spindle base. Replace the cover and tighten the four mounting screws.

Leveling:

Four square head set screws (502-1-12A), jam nuts (502-1-12F), and chamfered washer (502-1-12), are provided with the machine for leveling. Insert the screw and nut at the base support points, being careful that the screw point seats in the washer.

Use a precision level and level the upper table within .0005" per foot in both directions and make sure that the machine weight is equally supported at the four support points of the base.

Air Supply:

It is very important the air source for the SFOE machine be moisture free. Water and oil in the line will result in early cylinder and valve failure. ***Our recommendation is the installation of a water trap at the machine.***

Attach a 100 P.S.I. air source to the appropriate intake at the air filter on the side of the rear control enclosure.

Power Supply

This machine requires 208 to 240 VAC single phase, 50/60 Hz, (measured between L1 and L2). Current required is 15 amps.

When using two legs of a three phase supply the voltage from each leg to ground must be between 100-120 VAC. Connect per following electrical hook-up instructions. ***If the voltage is outside this range the machine will not operate properly and may be damaged.***

▲ CAUTION

Do not attempt to attach three phase voltage to this machine. The three phase spindle motor receives it's power from a three phase variable frequency drive in the rear enclosure. The frequency inverter is powered by single phase.

Connect single phase wiring to the blue and grey connection terminals in the upper right hand side of the rear enclosure. The machine is not neutral / hot leg sensitive so two legs of three phase 208-240 VAC can be used.

▲ CAUTION

This machine must be connected to a good earth ground. Connect the earth ground wire to one of the green/yellow terminals in the upper right hand side of the rear enclosure.

REFSF801-09292003

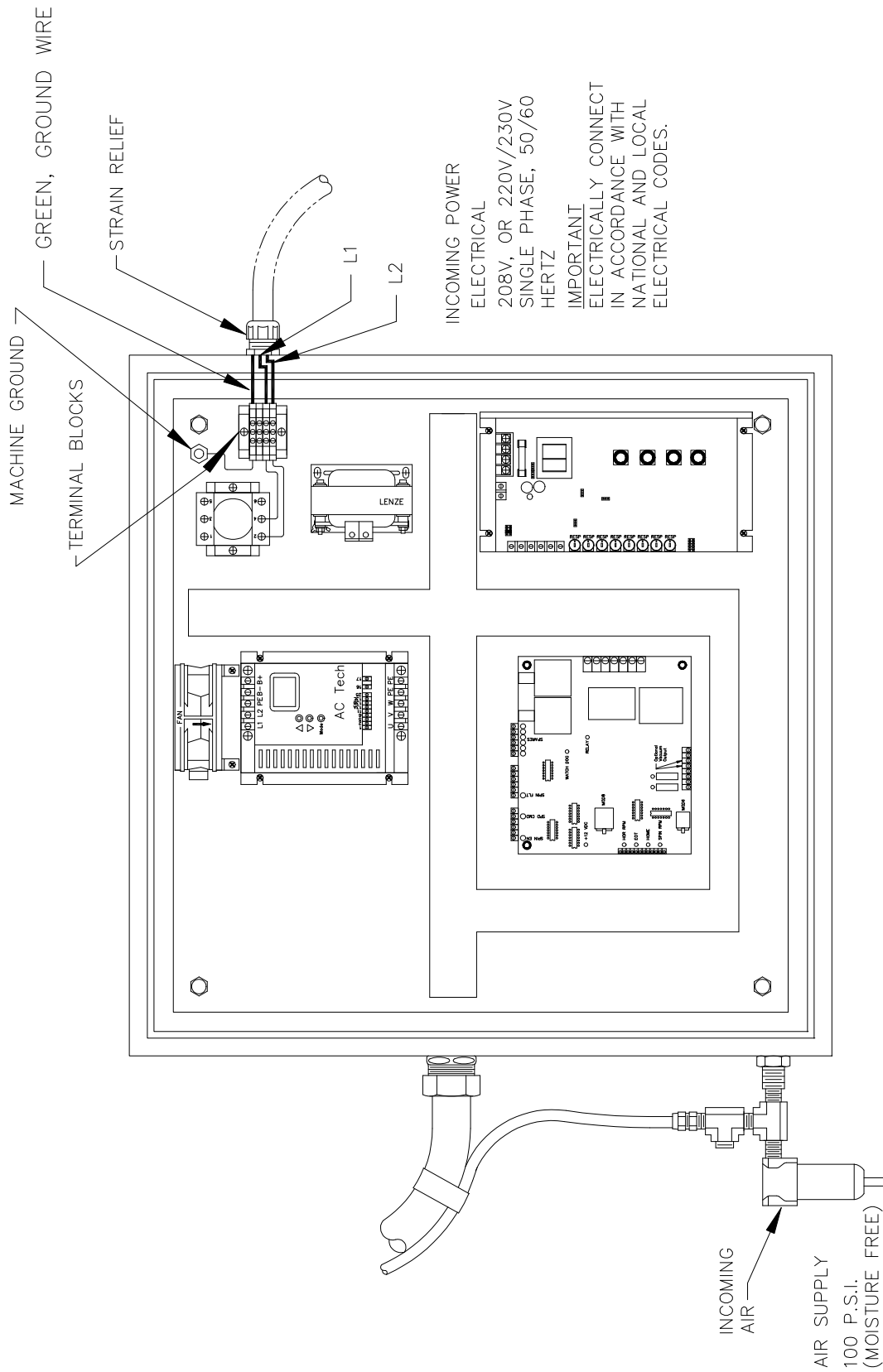

INCOMING POWER ELECTRICAL
 208V, OR 220V/230V
 SINGLE PHASE, 50/60
 HERTZ
 IMPORTANT
 ELECTRICALLY CONNECT
 IN ACCORDANCE WITH
 NATIONAL AND LOCAL
 ELECTRICAL CODES.

Chapter 2 Control Definitions

The purpose of this chapter is to define the function of buttons on the front control panel. Certain button functions may not appear clear when first reading this chapter. As the operator reads through the Operating Instructions chapter of this manual, these functions will become clear.

CPU Control:

This machine is under control of a CPU located in the rear enclosure

Master Power On/Off Switch:

This switch is located on the upper right hand side of the rear electrical cabinet. This switch must be in the Off position to open the rear enclosure.

When first applying power to the machine it will take a short while for the system to be ready for operation. Do not press any buttons on the control panel until the display show the standard operating screen.

Button Definition:

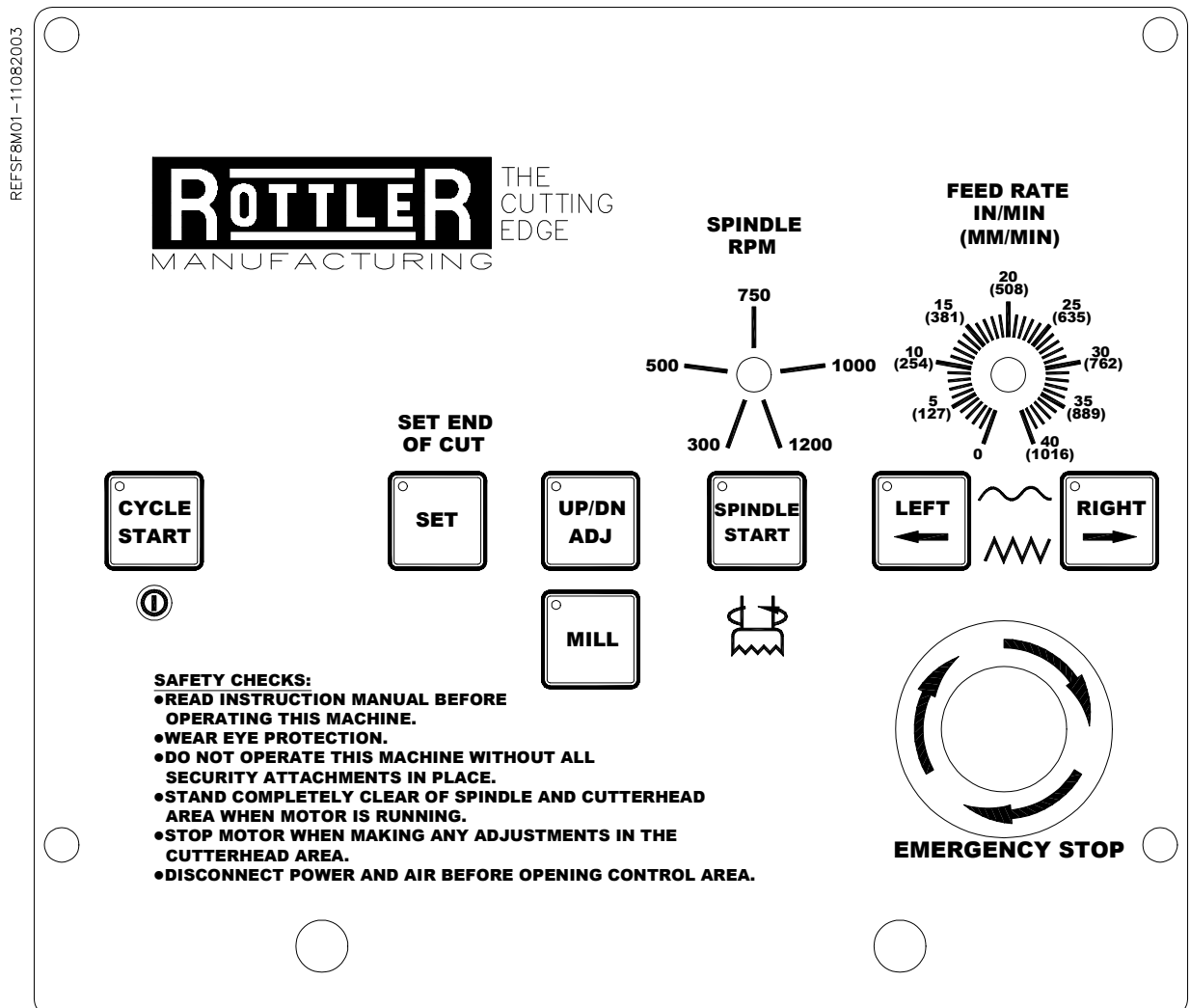

Emergency Stop:

IF the Emergency stop is pushed, all power to the spindle and horizontal drive is removed. Display will still have power and will display "EMERGENCY STOP". To release the emergency stop, turn the button to the right and it will "POP" out. Give the machine a minute to power up before pressing any buttons on the control panel.

Homing:

When the machine is first powered up it needs to be homed. The left and right buttons flash. The display also tells you to home the machine. Press and hold the Left and Right buttons for two (2) seconds. The machine will travel to the right at 50 inches per minute to find the home sensor.

Right:

This button has two functions. When pressed the machine will travel to the right at 80" per minute. Travel will continue until the button is pressed again or the right end of travel is reached.

If the spindle is on when this button is pressed, the machine will Feed to the right at the rate shown in the display. Travel will continue until the button is pressed again or the right end of travel is reached.

Left:

This button has two functions. When pressed, and held, the machine will travel to the left at 80" per minute until the button is released or the Left end of travel is reached.

If the spindle is on when this button is pressed, the machine will Feed to the left at the rate shown in the display. Travel will continue until the button is pressed again or the left end of travel is reached.

Spindle Start:

This button will start the spindle at the speed shown in the display. The spindle will continue to run until the button is pressed again.

The spindle will not start if any of the rapid travel or cycle buttons are active.

Up/Dn Adjust:

This button needs to be pressed before you use the manual hand wheel. Activating this button will put a small amount of air pressure on the lift cylinders to counteract the weight of the spindle and upper housing, this will make the handwheel easier to adjust. The Up/Dn Adjust function will operate if the spindle is turning, but not if Feed is active. Pressing this button cancels the Relief Up and Mill buttons.

Mill:

This button clamps the outer spindle to keep it from moving during a cut. The Mill button should be pressed before starting a feed move. The Mill button will work if the spindle is turning, but not if the Feed is active. Pressing the Mill button while in Relief Up will de-energize the Relief Up solenoid, allowing the spindle to drop the .020". A half a second later the spindle will be clamped. The Mill button cancels the Up/Dn Adjust mode.

End of Cut Set Button:

This button is used to set the End of Cut position. When pressed the physical location of the cutterhead will be the End of Cut position. More about the use of this button will be discussed later in this chapter under Auto Cycle and again in the Operating Instructions chapter of this manual.

Feed Rate:

The feed rate knob will change the feed rate. The available feed rate is from .001" to .040" per revolution of the spindle.

Spindle RPM:

The Spindle RPM knob will change the RPM. The available RPM is 350 to 1200.

Cycle Start:

Pressing this button will start an automatic cycle. To start an automatic manually move the machine over the work piece. Press the Up/Dn Adjust button, adjust the cutter head to the desired cutting height. Press Cycle start. The cutter head will start spinning at the RPM specified on the dial. Once the spindle is up to speed the horizontal feed will start at the rate specified on the knob.

When the end of cut position is reached the horizontal feed will stop. The cutter head will decal and then stop at an index point (cutters to the back and front of machine). The Right button will start to flash. Pressing the right button while it is flashing will cause the machine to rapid travel to the home position.

Spindle Auto Set-Up:

To run Spindle Self set-up. Press and hold the SET, UP/DN and SPINDLE START button for two seconds. The SET button will flash and the SPINDLE START button will light. Press and hold the SET button. The spindle will enable and drive to maximum speed, the speed will be measured by the controller and the drive will then decal and turn off the enable. Release the SET button. Press and hold the SET button then press the RIGHT button. This will leave the Spindle Self Set-up.

Horizontal Auto Set-Up:

To run the Horizontal Self set-up, press and hold the SET, UP/DN and LEFT buttons for two seconds. The SET button will flash and the LEFT and RIGHT buttons will light. Press and hold the SET button. The Horizontal drive will enable and Home if necessary. The control will then drive the spindle base to the left to measure the length of the base. The Control will then drive the spindle base at full speed to the right and then to the left to measure maximum encoder frequency. Release the SET button. Press and hold the SET button then press the RIGHT button. This will leave the Horizontal Self Set-up.

Manual Power Up:

To Manually power up the Spindle and Horizontal drive regardless of any error messages, press and hold the SET, UP/DN, LEFT and RIGHT for two (2) seconds. Press and release the E-Stop to exit this mode.

Surface Depth Dial Indicator:

This dial indicator is mounted on the surface of the cutterhead guard. When properly adjusted this indicator will show the position of the cutting insert relative to the surface to be cut.

Chapter 3 Operating Instructions:

Included in this chapter is a general description of how to use this machine for surfacing, whether it cylinder head, block or other type of job. For details of operating specific fixtures available on this machine refer to the Optional Surfacing Fixtures and Tooling section of this manual.

REFSF8M02-11082003

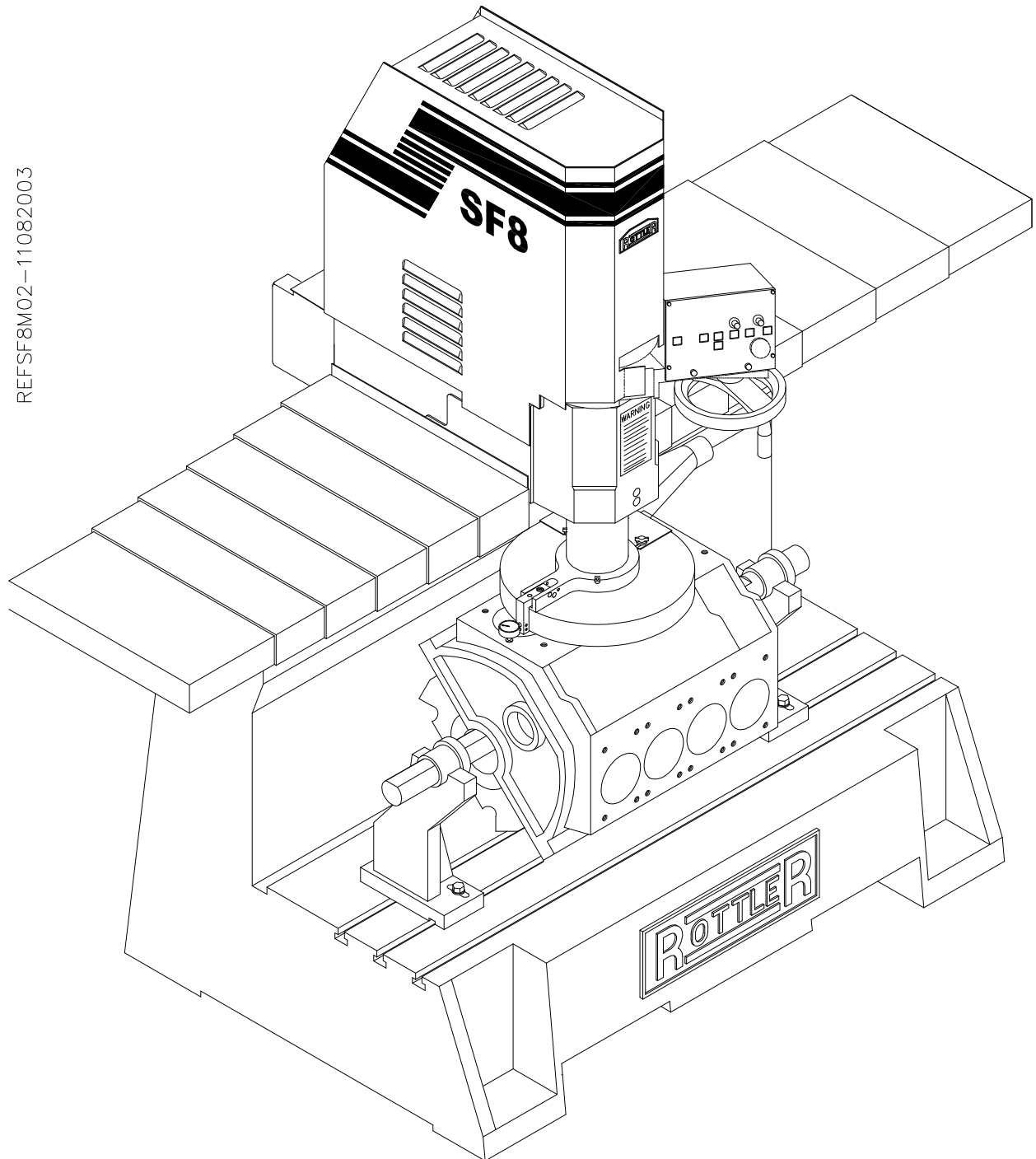

There are several ways to use the SF machine cutting system depending on the type of work you do and your personal preferences. Following are some details and descriptions that will help you decide which method is best suited to your application.

Manual Operation:

Press the Left rapid travel button and move the spindle over to the starting position. The starting position is just before the cutterhead guard passes over the work piece. Push the dial depth indicator, on the guard, down onto the top of the work piece. Assuming the dial indicator has been properly adjusted (see the Maintenance chapter of this manual for adjustment instructions) it will indicate the depth of the cut at your current height setting.



Press the Up/Dn Adjust button, adjust the depth of the cut using the manual handwheel. Press the Mill button to clamp the spindle. Adjust the Feed Rate and Spindle RPM knob for the desired finish. Press the Spindle Start button and the Feed Left button. The machine will start Feeding across the work piece.

When the machine has finished cutting, press the Left travel button to stop the feed, then the Spindle Start button to stop the spindle. You must manually lift the cutterhead then press and hold the right travel button back to the home position.

Operation:

Press the right and left travel buttons and hold for two seconds, the machine will move to the Home position. Press the Left rapid travel button and move the spindle over to the starting position. The starting position is just before the cutterhead guard passes over the work piece.

Push the dial depth indicator, on the guard, down onto the top of the work piece. Assuming the dial indicator has been properly adjusted (see the Maintenance chapter of this manual for adjustment instructions) it will indicate the depth of the cut at your current height setting.

Press the Up/Dn Adjust button, adjust the depth of the cut using the manual handwheel. Adjust the Feed Rate and Spindle RPM knobs for the desired finish. Press the Cycle Start button, the spindle will come

up to speed then the left feed will start. When the cutterhead clears the work piece press the SET button. This will set the end of cut for the next pass.

If a cycle is started with an end of cut position already set, the machine will stop the spindle and left feed at this position. The cutterhead will index so the cutter is not over the work piece. The Right LED will then flash. Pressing the right buttons when it is flashing will cause the machine to rapid right to the home position.

You can manually move the machine to the end of the work piece and press the End of Cut Set button before you start the cycle. If this is done you will not need to press this button after the cut is finished.

▲ CAUTION

Be careful when starting a cycle. The machine will cut to the last End of Cut set position. If no End of Cut position has been set the automatic cycle will not start. An End of Cut position must be set after every power up. When the power is turned off to the machine, the end of cut is reset to zero.

Cutting Inserts:

Rottler offers several different 3/8" and 1/2" IC negative rake inserts for the SF machine. Below is a description of each.

6303B

A round 3/8" IC, double sided, CBN Insert. An excellent, long life insert for surfacing cast iron heads and blocks -round shape gives many cutting edges on each side of insert. When using a 14" cutterhead (SF, F65, F80) speeds range from 900-1200 RPM. When using an 18" cutterhead (F80) speeds range from 600-800 RPM.

6303M

A round 3/8" IC, single sided, PCD Insert. For use on aluminum only - heads and blocks without liners. This insert has a thin layer of PCD applied to a carbide disk. The diamond appears to be a shiny black wafer. The hardness of the diamond resists the abrasive nature of the silica in aluminum heads and blocks. RPM speeds with a 14" cutter range from 900-2000 RPM.

6303K

A round, 3/8" IC, single sided, coated carbide Insert. This is a very economical, general purpose insert for surfacing aluminum. It is advisable to use this insert for rough cutting to remove welding or contaminants before. A PCD insert should be used for the final cut to give the super fine finish required for MLS (multi layer steel) head gaskets. RPM speeds with a 14" cutterhead range from 600-1000 RPM.

6303S

A round 3/8" IC, single sided, CBN Insert. For use on aluminum blocks with iron liners and aluminum heads with steel pre-combustion chambers. When cutting aluminum heads with pre-combustion chambers it is best to use Rottler Manufacturing's spray mist coolant system. RPM speeds with a 14" cutter range from 650-750 RPM.

6303R

A round 3/8" IC, single sided, CBN Insert. For use on cast iron heads with steel pre-combustion chambers. RPM speed with a 14" cutter range from 600-700 RPM and with a 18" cutter range from 500-600 RPM.

It is critical that the heads be mounted in the fixture correctly. If the head is not mounted in this way, the inserts will chip when they contact the sharp of the pre combustion chamber.

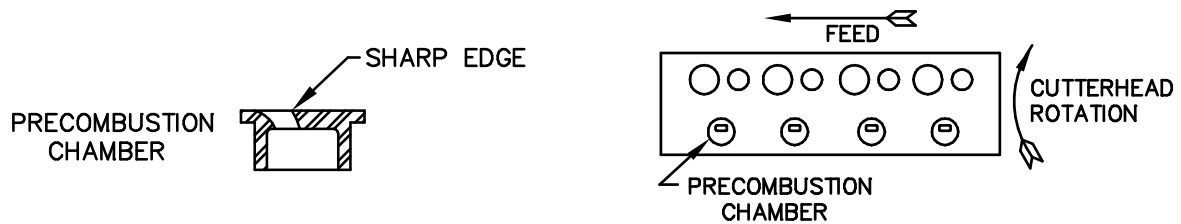

Note: *There are at least two different materials used in the manufacture of the pre-combustion chambers. Rottler Manufacturing has experimented with only one of these materials. Rottler cannot guarantee cutting all materials.*

501-29-6E R2

This is a 3/8" IC square carbide insert with a purple ceramic coating. This carbide insert is normally used for high speed boring. It works well as an economical insert for rough surfacing or heavy stock removal of cast iron. A CBN insert should be used for the final finish cut.

6301J

A square 3/8" IC, 1/16" Radius, double sided, CBN Insert. The 1/16" radius of this insert will produce a more accurate (flatter) finish than a round insert typically used for surfacing. This insert is often used on F80-Series machines when surfacing large diesel blocks which are high in nickel. The square surfacing insert is intended for F80 applications where it may encounter heavier cuts and greater interrupted cuts. When using an 18" cutter speeds range from 600-800 RPM, and with a 14" cutter speeds range from 900-1200 RPM.

6303P

A round 1/2" IC, single sided, PCD Insert. For use on aluminum only - heads and blocks without liners. This insert has a thin layer of PCD applied to the top of a carbide disk. The diamond appears to be a shiny black wafer. The hardness of the diamond resists the abrasive nature of the silica in aluminum heads and blocks. RPM speeds with a 14" cutter range from 1000-2000 RPM. This insert gives the maximum productivity when cutting aluminum. Requires the purchase of 1/2" negative rake tool holders. The standard Rottler 3/8" IC tool holders will not hold this insert.

6303Q

A round 1/2" IC double sided, CBN Insert. An excellent insert for machining cast iron heads and blocks. Round shape gives many cutting edges on each side of insert. Requires the purchase of 1/2" negative rake tool holders. The standard Rottler 3/8" IC tool holders will not hold this insert.

▲ CAUTION

The pre-combustion chambers in some heads have a very loose fit and may come loose during the machining process resulting in damage to the insert.

One Insert vs. Two Inserts:

Rottler SF machines can be run effectively with either one or two inserts installed in the cutterhead.

Note: *Never remove one tool holder that holds the insert and run the machine with one insert. This will create an out of balance situation.*

If two inserts are installed and aligned within .0001 of an inch the feed rate can be run 2 times faster than if using only one insert.

The depth of the grooves made by the inserts for a typical finish is approximately .0003. Therefore for a second insert to be of any advantage in obtaining a smoother finish for a given feed rate or a similar finish at a higher feed rate the inserts must be aligned within .0003. Aligning them within .0001 will give you a

significantly smoother finish than aligning them within .0002. Therefore for maximum quality and consistency Rottler recommends aligning the inserts within .0001 in a vertical plane, alignment of the horizontal plane within .002 is sufficient.

If aligning the inserts within .0001 is too time consuming we recommend mis-aligning them between .0003 and .0015. With the inserts mis-aligned you will get the same finish for a set RPM and feed rate that you would using one insert. The benefit on using two inserts is for stock removal. Since the one mis-aligned insert is removing some material the depth of cut can be increased up to .010 and acceptable tool life obtained.

If one insert is used (50 percent of our customers use one insert) you do not have to worry about alignment. It makes it very easy to change from CBN to coated carbide inserts. The following data assumes you are using a 3/8" diameter insert, either CBN or coated carbide.

General Information

Rottler CBN and PCD Inserts are laser marked with our part number on one side. On single sided inserts, the part number is on the back side of the insert.

Rottler surfacing insert toolholders are designated IC (inscribed circle) which means they can hold square and round inserts with the same IC, for example, a 3/8" IC round and 3/8" IC square insert will fit into the standard 3/8" IC Rottler toolholders.

Rottler SF, F65 and F80 Series machines are supplied standard with Rottler 3/8" IC toolholders fitted to our surfacing heads. Optional 1/2" tool holders are interchangeable with 3/8" toolholders.

Cutting Speed Calculation

Inserts are designed to cut within a speed range (S.F.P.M.). In order to convert from cutting speed to RPM, use the following formula:

$$\text{RPM} = \frac{\text{S.F.P.M.} \times 3.82}{\text{DIAMETER}}$$

S.F.P.M. = Surface Feet per Minute
 RPM = Revolutions per Minute
 DIAMETER in Inches

	One Insert	Two Inserts Set within .0015" - .0003	Two Inserts Set within .0001"
RPM 1000 Feed Rate .002" Per Rev	12 rms	12 rms	10 rms
RPM 1000 Feed Rate .005" Per Rev	20 rms	20 rms	15 rms
RPM 1000 Feed Rate .010" Per Rev	30 rms	30 rms	25 rms
RPM 1000 Feed Rate .020" Per Rev	60 rms	60 rms	40 rms
RPM 1000 Feed Rate .030" Per Rev	90 rms	90 rms	60 rms

Chapter 4 Maintenance

Lubrication:

Refer to the illustrations on the following pages.

Ballscrew Nut:

The ballscrew nut is located under the Spindle base inside the Main Base.

Every 175 hours, Grease the ball screw nut using **F2 Multi-purpose Grease, or Unoba F1 Grease**, or equivalent. Wipe a small amount of grease on the screw just ahead of the nut.

Outer Spindle:

The Outer Spindle is the cylinder that travels up and down. It is supported in outer spindle bushings.

Every 40 hours, The Outer Spindle should be cleaned with **Kerosene**. And occasionally a **light weight oil** applied to prevent excessive dryness.

Inner Spindle:

The Inner Spindle is located inside the Outer Spindle. The Inner Spindle is directly connected to the cutterhead.

Every 40 hours, Add 2 or 3 drops of oil, **Union oil 315 Klondyke oil, or any SAE #10 oil (non detergent motor oil)**.

Every 175 hours, Add one shot of, **Union oil - Unoba F1 or F2 lube, Lubriplate #930 AAA, Mobil oil - Mobilith A.W. grades 1 or 2, Chevron Durolith EP1 or EP2**, or any equivalent lithium barium grease. Run the spindle down near the lower limit and you will see a flush type grease fitting in the keyway. Add lubrication here. If the inner spindle is removed clean the lower bearing and repack it with grease.

Vertical Adjustment Nut:

This nut is what makes the spindle travel up and down when the handwheel is turned.

Every 40 hours, Add 3 squirts of **spindle oil** to the flush type grease fitting located as shown on the **illustration. Lubrication 2-Axis Universal Machine Table 7119Q:**

Every 175 hours, Add 2 or 3 shots of grease to the grease fittings shown.

Every 40 hours, clean and apply grease to the bearing surfaces of the journals.

Every 1,000 hours, Disassemble, clean and grease the spherical washer.

Use **F2 Multi-purpose Grease, Chevron Durolith**, or equivalent.

Cleaning The Way Surface:

Do not clean way surfaces with abrasive or harsh cleaners, The sliding way material used under the spindle base, must "break in" which will deposit a small amount of the material into the top of the main base. Discoloration will occur in slides. If the way surface is cleaned of these deposits, the "break in" action will start all over. If this cycle is repeated premature wear will result.

Spindle Lock Cylinder:

The outer spindle on the SF series machines have an air operated lock system. This cylinder is nickel plated to help avoid rust but the water still needs to be drained occasionally.

Every 6 months, Drain the water from the spindle lock cylinder. Disconnect the air line from the machine. Remove the two 1/2" pipe plugs located in the front of the spindle base near the bottom edge. Reconnect the air line. Press the Mill button, and let the air run out for a few moments. Press the Relief up button, and let the air run out for a few moments. Disconnect the air line again and replace the two pipe plugs, tighten, operate as normal.



WARNING This system is under pressure, machine damage and or personal injury may occur if the plugs are removed without first disconnecting main air supply.

Lubrication – Quick Reference Chart:

Refer to the previous page for types of lubrication to be used.

Assembly	Frequency	Lube Operation
Ballscrew Nut	Every 175 hours	Grease ballscrew nut
Outer Spindle	Every 40 hours	Clean and wipe with oil
Inner Spindle	Every 40 hours	Add 2 to 3 drops of oil
Inner Spindle	Every 175 hours	Add Oil
Vertical Adjustment Nut	Every 40 hours	Add Oil
Vertical Adjustment Nut	Every 175 hours	Grease, grease fitting
Vertical Adjustment Nut	Every 40 hours	Apply Grease
Vertical Adjustment Nut	Every 1,000 hours	Clean and Grease spherical washer
Way Surface	Every 175 hours	Wipe and oil way surface
Spindle Lock Cylinder	Every six months	Drain spindle lock cylinder

SF7M -8A Machine Lubrication Illustration:

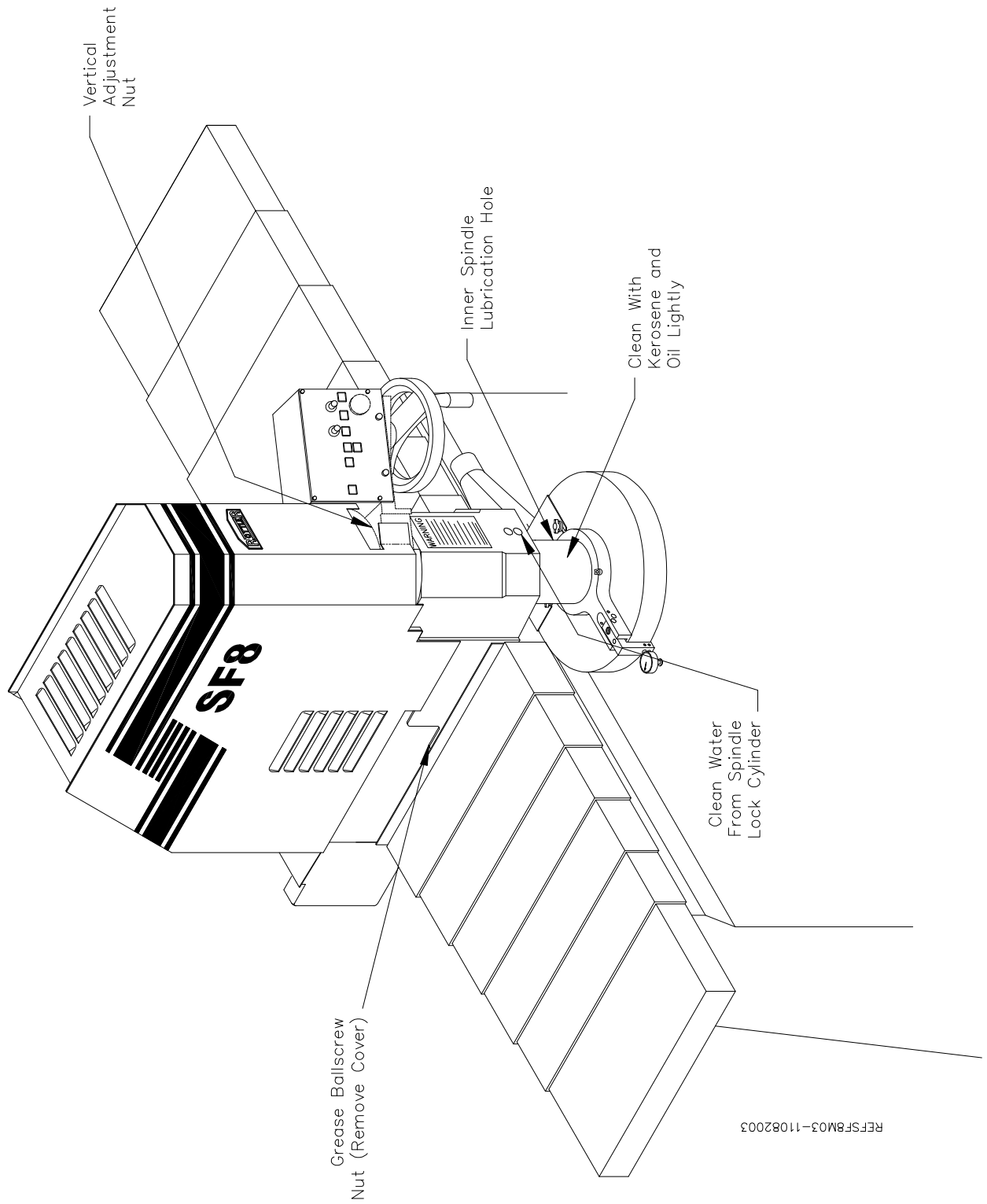

2 Axis Universal Machine Table 7119Q – Lubrication Illustration:

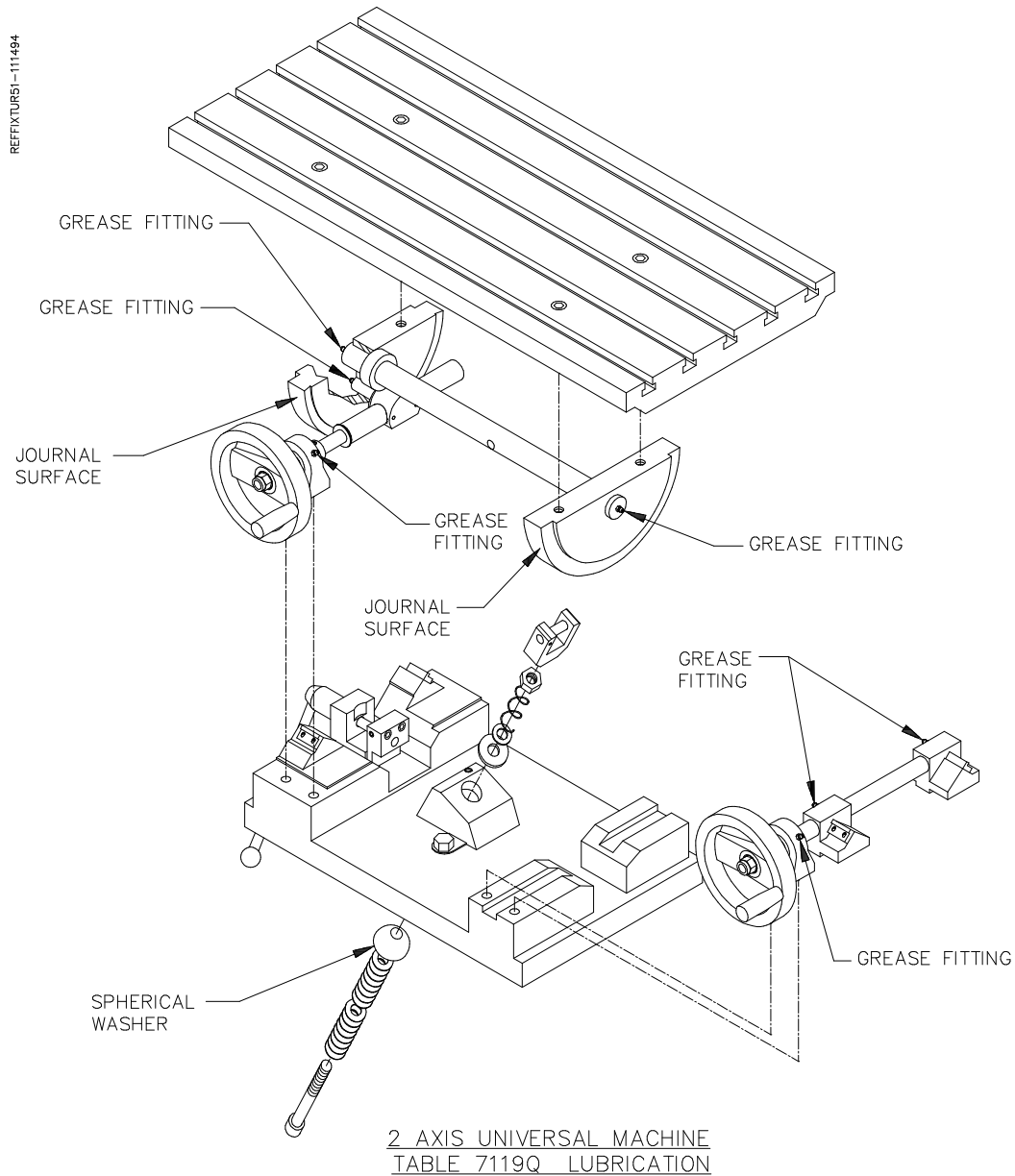

Setting Cutting Tool Inserts

Press the Mill button. Travel the spindle base approximately to the center of the main base.

CAUTION Turn off all power to machine before proceeding.

Remove vacuum housing from chip shield. Attach a dial runout indicator to a cylinder head or engine block, etc.

Rotate cutter head and check to see that both inserts are the same distance from the center of the spindle, within .004. If adjustment is necessary loosen the tool holder clamp wedge, and the height adjustment screw. Move tool in or out the required distance. Tighten the clamp wedge. Snug up the height adjustment screw. There is a set screw located at the bottom of the toolholder, it locks a dowel pin in place. When the in-out adjustment is set, loosen the set screw, the pin will pop out and hit the back of the slot. Tighten the set screw. This way, when a tool holder is removed and then replaced, it will be located very nearly where it was. Insert height will still need to be adjusted.

Rotate cutter head and check to see that both inserts are the same height within .0015-.0003. If adjustment is necessary loosen the tool holder clamp wedge, then alternately loosen and tighten the height adjusting screw and the retaining screw, until both inserts are set as desired. Retighten the tool holder clamp wedge, and recheck both inserts.

Production Cutting

Aluminum & Cast Iron:

For fast tooling set-up, this machine can be set-up with one cast iron cutting insert and one aluminum cutting insert. Set the cast iron insert with no down or out adjustment. Set the aluminum style insert .02 further out and .005 lower than the first insert. With the cutter head set up this way, aluminum work can be easily cut. To cut cast iron simply remove the aluminum cutting insert from its holder.

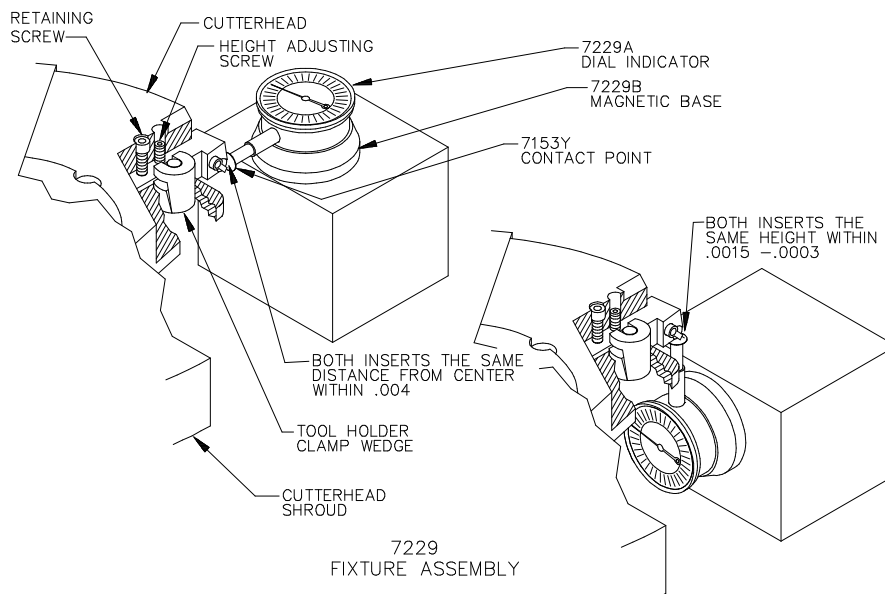

Dial Indicator Setting

If chip shield, cutting insert, or dial indicator have been moved, the dial indicator should be reset.

To reset press the up/down adjust button. With the surfacing cutter in the fore and aft position, press the left travel button until the cutterhead overlaps a test piece by about 1/2" when rotated.

▲ CAUTION

Turn off all power to the machine whenever handling the cutter head.

Touch off surface, by turning hand wheel clockwise until cutter insert just touches test piece surface when rotated back and forth.

Note: Do not lower the cutter head directly onto surface, it may chip the cutting tool insert.

Make a very light cut on your test piece about one inch in. Back out and without adjusting the height press the dial indicator down on this surface. Adjust it by: Removing the lock screw. Then turn adjusting screw up or down until the dial indicator is half way between its minimum and maximum range.

Replace the lock screw and tighten firmly.

Set dial to zero.

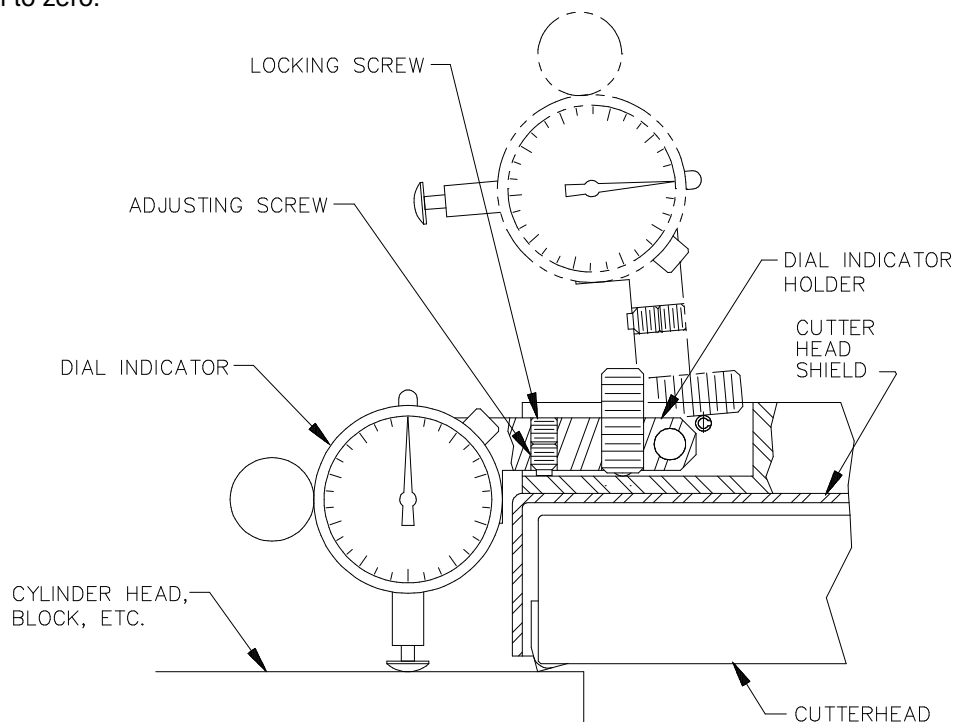

Vertical Travel Chain Removal and Replacement:

CAUTION

Turn off all power to the machine before continuing.

Remove the two screws securing the control panel, lay the panel and the enclosure aside.

Remove four screws from the chain cover, and lift it off.

Remove the access panel at the rear of the machine enclosure. Remove the six screws mounting the enclosure to the machine. Four screws are located inside the enclosure and are accessed through the rear opening. The other two screws are in the front and the front right side, from the outside. Lift cover off the machine carefully. (As cover is lifted slide forward and up to clear motor and belt case.)

Loosen the locknut, and the two bolts, on the adjusting block. Move the sprocket all the way in by turning the adjusting bolt.

Locate a master link in the chain and remove it. Remove the chain. Slide the new chain through the opening around the large sprocket and reconnect the master link.

Place the chain over both sprockets, and take up the slack by turning the adjusting bolt. The chain should have approximately 1/4 inch play measured midway between the sprockets.

CAUTION

Do not over tighten the chain or the vertical spindle positioning system could fail.

Lock the adjusting bolt with the locknut. Tighten the two bolts in the adjusting block.

Replace both covers, and place the control panel back in position and tighten its mounting bolts.

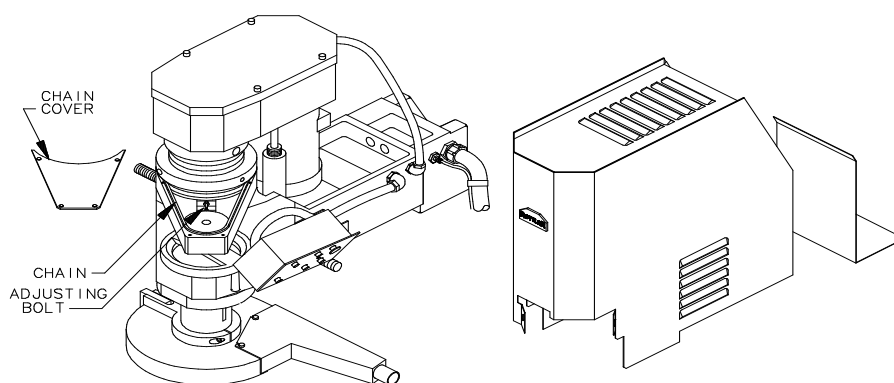

Drive Belt Replacement:

CAUTION

Turn off all power to the machine before continuing.

Remove the access panel at the rear of the machine enclosure. Remove the six screws mounting the enclosure to the machine. Four screws are located inside the enclosure and are accessed through the rear opening. The other two screws are in the front and the front right side, from the outside. Lift cover off the machine carefully. (As cover is lifted slide forward and up to clear motor and belt case.)

Remove the four screws holding the upper cover. Lift cover off.

Loosen the four motor mount screws.

Loosen the belt tension screw.

Lift the belt off. Replace with new belt (7014F).

Tighten belt tension screw, until belt has 1/8 to 3/16 inch deflection, with 1-1/2 to 3 pounds pressure, measured in the middle of the belt.

Tighten the four motor mount screws.

Replace the upper housing cover and tighten the four screws.

Replace the machine enclosure and tighten the mounting screws.

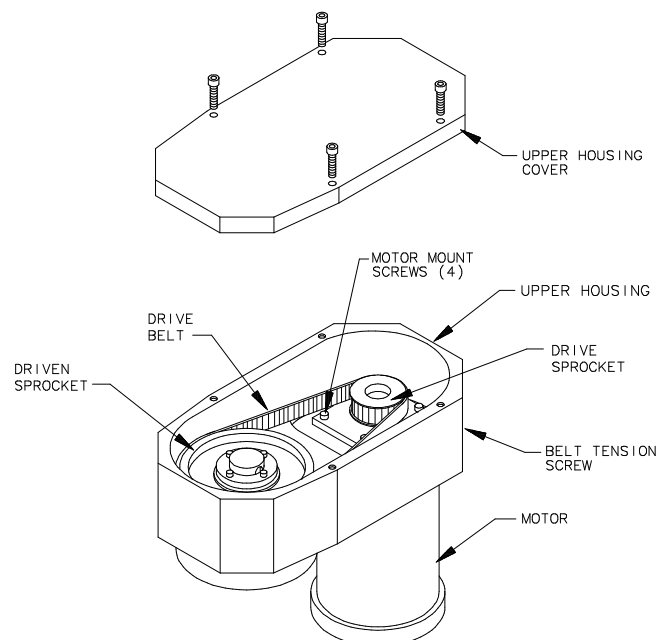

Drive Sprocket / Motor Removal and Replacement:

⚠ CAUTION

Turn off all power to the machine before continuing.

Removal of Drive Sprocket:

(Small sprocket)

Remove the upper housing cover, and drive belt, as explained on page 4.7.

Place something under the spindle drive motor to support it. Remove the four 3/8 -16 motor mounting screws from inside the upper housing. Lower the motor, with the drive sprocket attached, out of the upper housing.

Remove three screws, located on the bottom of the sprocket bushing, between the bushing and the motor. Use three screws, in the threaded holes in the bushing, to loosen the bushing from the sprocket. Lift off sprocket.

Replacement of Drive Sprocket:

(Small sprocket)

Clean bushing, and sprocket. Do not use any lubrication on bushing, sprocket, or screws.

Locate **BUSHING** flush with the end of the motor shaft. Tighten the #10-24 unc screws in the bushing **EVENLY** to 5 to 6 ft. lbs.

Install motor back into upper housing and tighten the four motor mounting screws.

Replace the drive belt, and adjust, as indicated in drive belt replacement.

Replace upper housing cover and tighten the four screws.

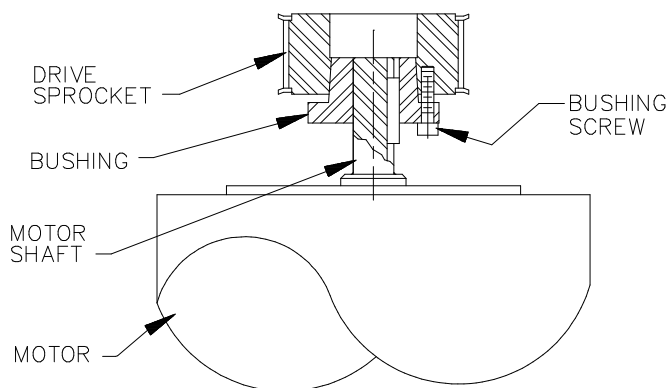

Driven Sprocket Removal and Replacement:

▲ CAUTION

Turn off all power to the machine before continuing.

Removal of Driven Sprocket:

(Large Sprocket)

Remove the upper housing cover, and drive belt, as explained on page 4.7.

Remove the three 1/4-20 screws located on top of the sprocket bushing. Insert these bolts into the threaded holes in the top of the bushing. Turn these screws in evenly to force the bushing and sprocket apart.

Remove driven sprocket, the bushing, and the key.

Replacement of Driven Sprocket:

(Large Sprocket)

Clean bushing, and sprocket. Do not use any lubrication on bushing, sprocket, or screws.

Align the driven sprocket so that the bottom edge is slightly lower than the drive sprocket. Tighten the four 1/4-20 screws, located on top of the driven sprocket bushing, EVENLY to 9 to 10 ft. lbs. Check to see that it does not wobble.

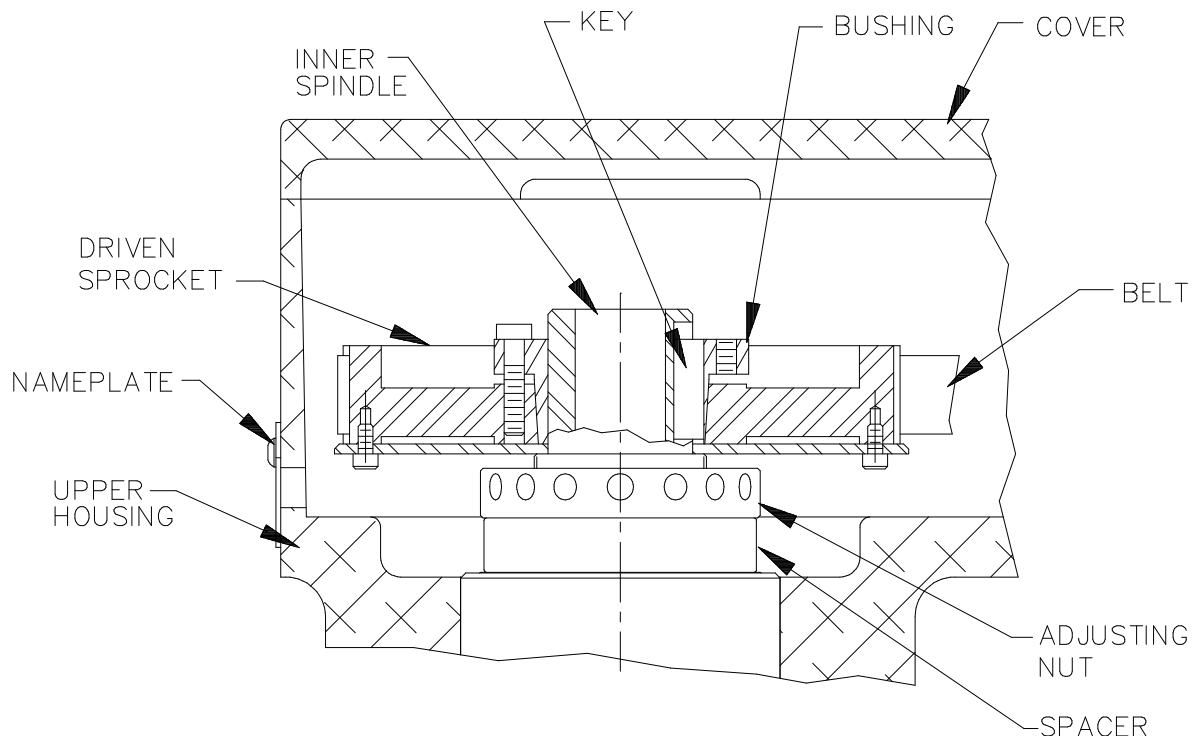

Cutterhead and Chip Guard Removal:

CAUTION

Turn off all power to the machine before continuing.

Mark cutterhead and spindle so they can be reassembled in the same position. Remove cutterhead by removing its four 3/8-16 screws. Remove chip guard by removing its two 1/4-20 set screws that go into the clamp ring at an angle, and loosen the 3/8-16 capscrew in the split line of clamp ring. Remove cover.

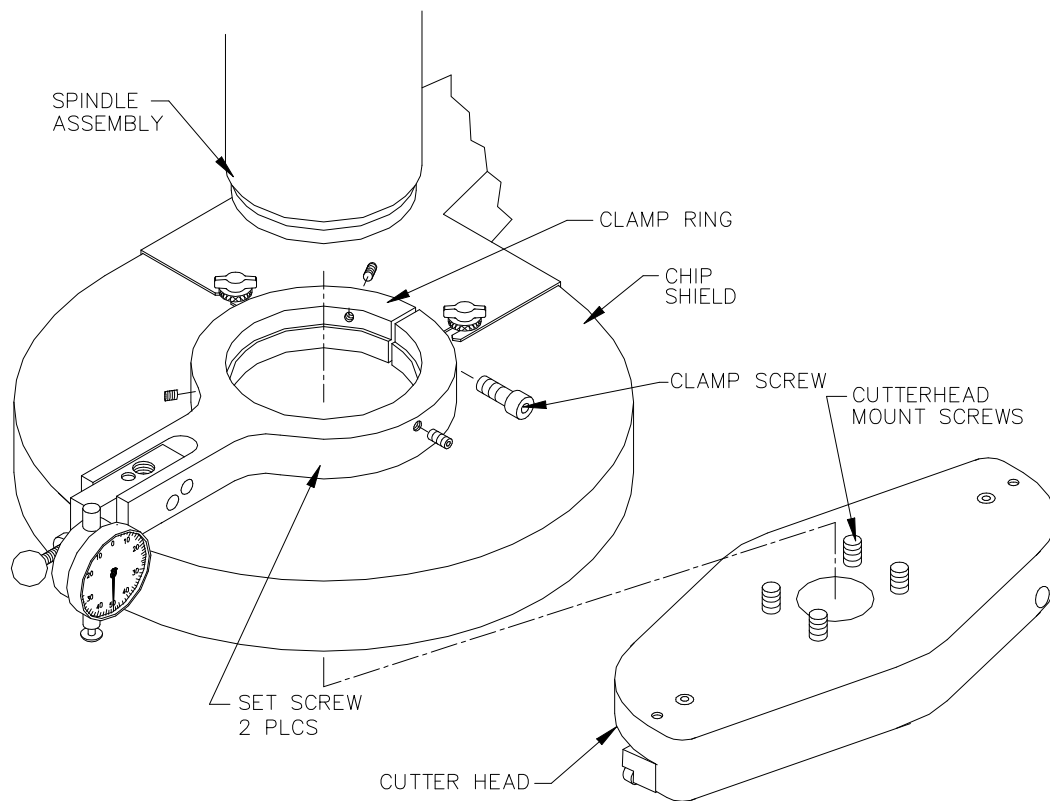

Upper Housing Removal:

CAUTION

Turn off all power to the machine before continuing.

Remove the Drive Belt, Motor and Driven Sprocket and described earlier in this chapter.

Remove the shoulder bolts holding the top of the air cylinders to the upper housing. Compress the air cylinders and lay them out of the way.

Remove the mounting screws holding the outer spindle Boot to the Upper Housing. Remove the two bolts, located at the top of the Outer Spindle. The Upper Housing will lift off. It may require some turning as you lift to get it off.

Reassembly is the opposite of disassembly. Be sure the Outer Spindle and Upper Housing mating surfaces are clean and free from burrs.

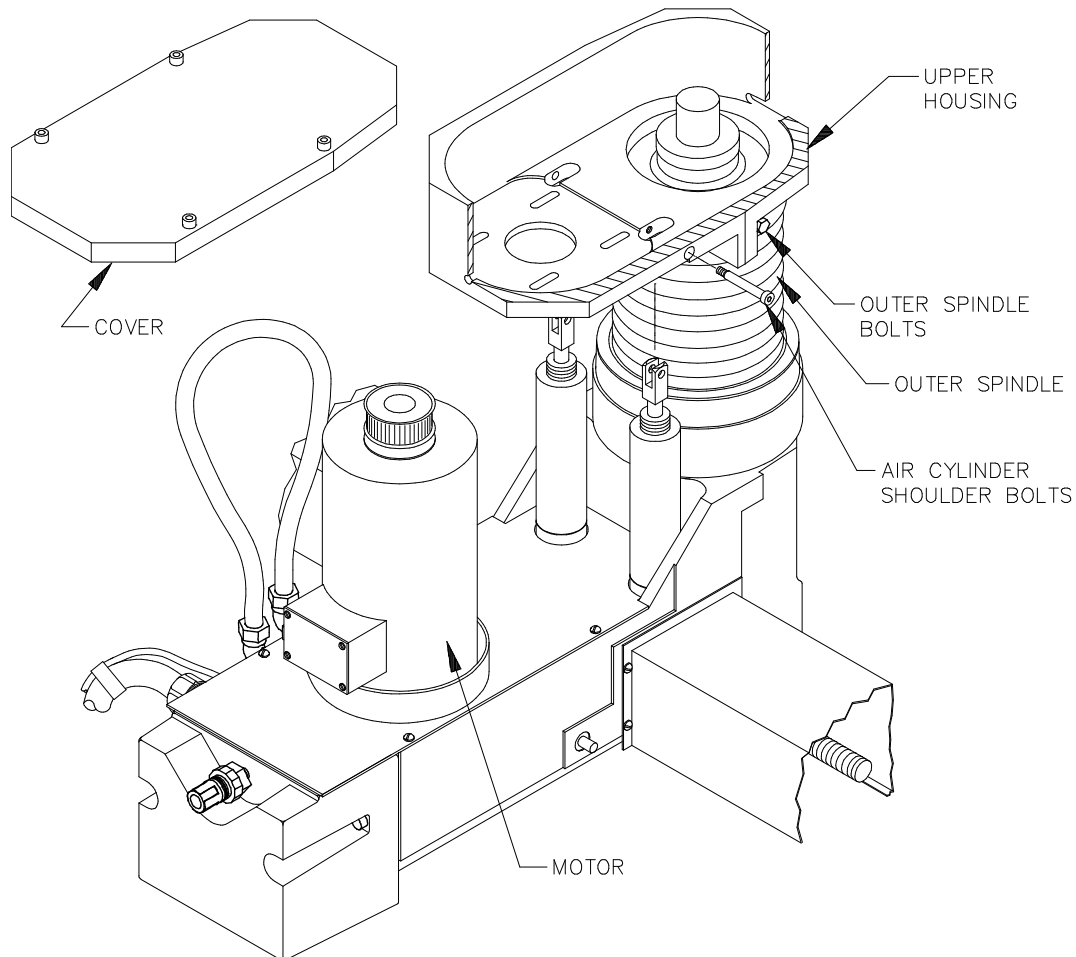

Outer Spindle Removal:

CAUTION

Turn off all power to the machine before continuing.

Remove the cutter head and cover as described earlier in this chapter. Remove the upper housing as described earlier in this chapter.

Remove the screws in the retainer, holding the outer spindle boot and lift off the boot and the retainer. Remove the Vertical Drive Chain as described on page 4.6 Remove the screws holding the drive ring to the outer spindle nut. Lift the drive ring off. Remove the mounting screws of the chain drive housing and lift it off the outer spindle.

At this point the outer spindle nut is holding the spindle up, keeping it from falling out. The spindle key, retaining screw must be removed. The key should slide down the key slot and end up inside the spindle base. Looking in the hole inside the spindle base, turn the spindle counter-clockwise 90 degrees. You should be able to see the key and remove it. The spindle is now free to lift out. Lift straight up so you don't bind it in its guide bushings.

To reassemble: Slide the spindle assembly straight into the bushings. Slide it down until a couple inches of the outer spindle keyway is extending from the bottom of the spindle base. From the top of the upper bushing, below the nut, insert the key in the keyway. Slide it into the matching keyway in the bushing. As it starts into the bushing, turn the spindle with your hand to put a slight drag on the key, or it will fall all the way through. Lightly tap the key down into the bushing until you can thread the screw into the key.

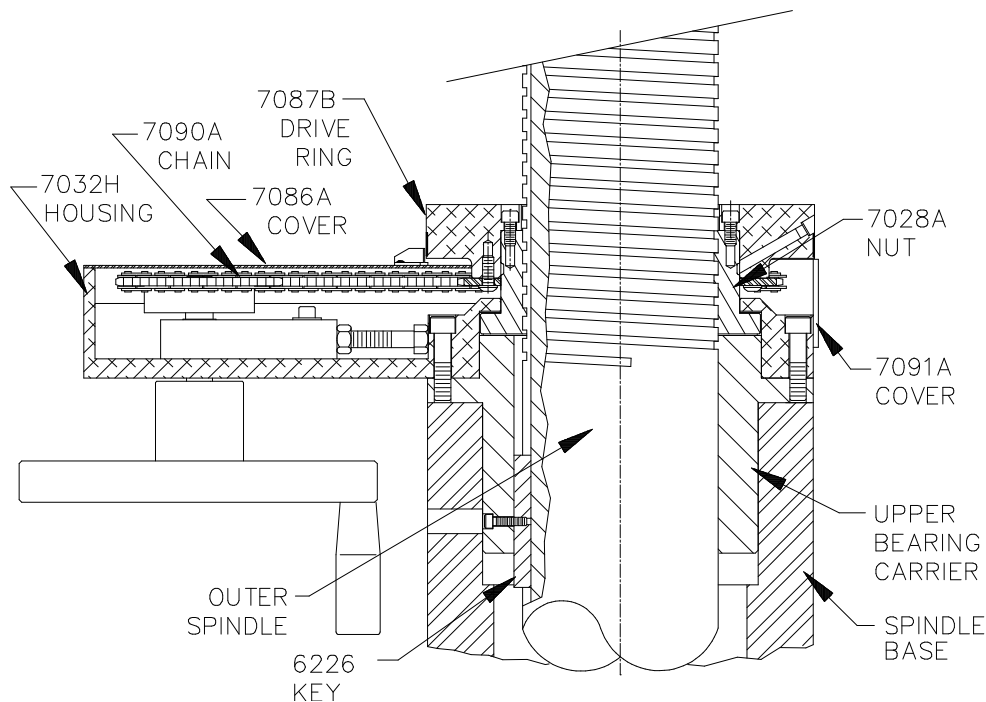

Inner Spindle Removal:

CAUTION

Turn off all power to the machine before continuing.

Remove the upper housing cover, and drive belt, as explained on page 4.7.

Remove the driven sprocket as explained on page 4.9.

Remove the cutterhead and chip guard as explained on page 4.10.

Crank spindle up to its full up position.

Remove the Rottler nameplate from the front of the upper gear housing.

Insert a rod or punch through this opening and into the upper adjusting nut (7020). Holding the cutterhead, loosen this nut by turning it counter-clockwise. Remove nut, spacer (7019), key (6043), and two Belleville spring washers (7052).

Thread upper adjusting nut (7020) back onto inner spindle to keep the spindle from falling out, after throwback nut is unthreaded.

Take a rod or punch and insert it into one of the holes in the outside of the throwback nut. This nut is located between the bottom of the outer spindle and the lower flange of the inner spindle.

Turn the nut counter-clockwise to loosen. As you back off the nut, tap on top of the inner spindle with a soft mallet. Do this until the nut is threaded out of the outer spindle.

Place something under inner spindle, then unthread the upper adjusting nut.

Slowly lower the inner spindle out of the outer spindle.

Upper Spindle Bearing Removal:

Use a puller or a long bar from inside the outer spindle, to carefully remove the upper bearing.

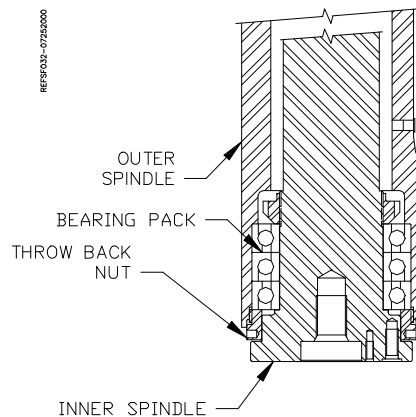
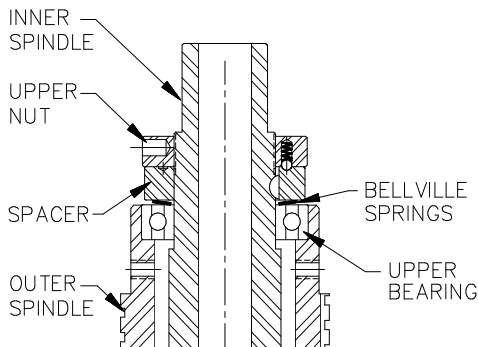

Spindle Lock Removal:**CAUTION**

Turn off all power to the machine before continuing.

It is not necessary to remove the outer spindle before removing the spindle lock assembly.

Remove rear spindle base cover. Locate the two air lines and fittings, located in the very front of the spindle base. Disconnect by pushing the plastic ring and pulling the tubing at the same time. (Be sure you mark the air lines correctly for reassembly). After the air lines are removed rotate the fittings in toward the outer spindle.

Remove the screws holding the lower retainer in place. Pull the retainer off, be careful not to lose the rubber wipers or the felt packing.

Loosen the three set screws in the lower front and both sides of the spindle base. Loosen and remove the bolts coming up from the bottom of the lower bushing.

CAUTION

the bushing, Piston guide and manifold will all come out at the same time. These are precision parts, do not drop.

Reassembly:

Inspect parts for damage and excessive wear. Replace the O-rings on the piston and guide. Reinstall the parts carefully, Do Not damage the o-ring seals.

Assemble the piston into the bottom of the manifold. Next assemble the piston guide. A small amount of lubricant may be necessary to get the o-rings to slide. Extending from the top of the manifold is a roll pin. This pin fits into a hole up in the spindle base. Slide the lower bushing up in place and secure with its mounting bolts.

Follow the procedure described later in this chapter to adjust the cutter head tilt.

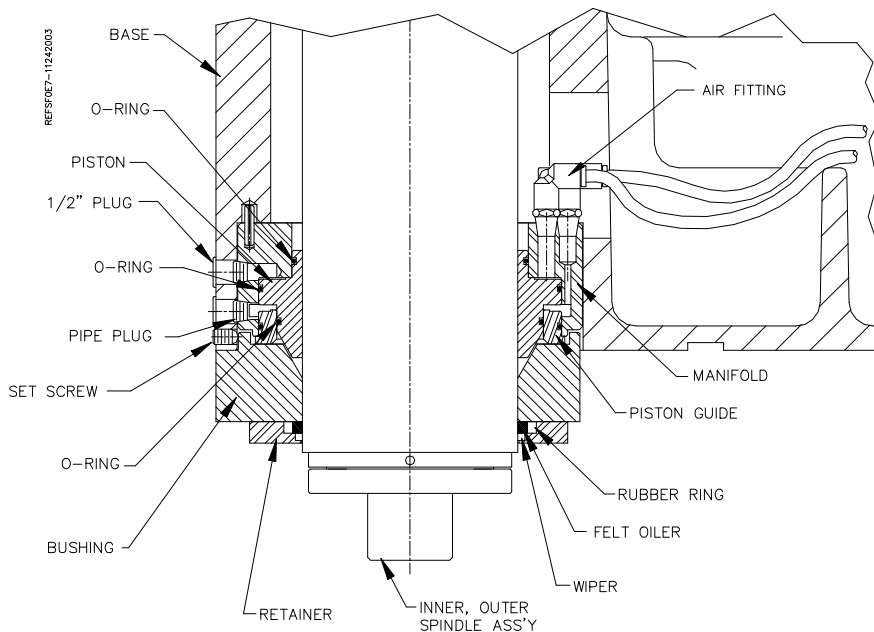

Spindle Sensor Adjustment:

▲ CAUTION

Turn off all power to the machine before continuing.

Remove the spindle sensor from the spindle housing lid.

Rotate the spindle until the dowel pin on the end of the inner spindle can be seen. Measure the distance between the dowel pin and the top of the lid.

Adjust the upper nut on the sensor to match the measured distance minus .030". Install the sensor from the top and then tighten the lower nut on the sensor.

Turn the spindle by hand to make sure the dowel pin is not coming in contact with the sensor.

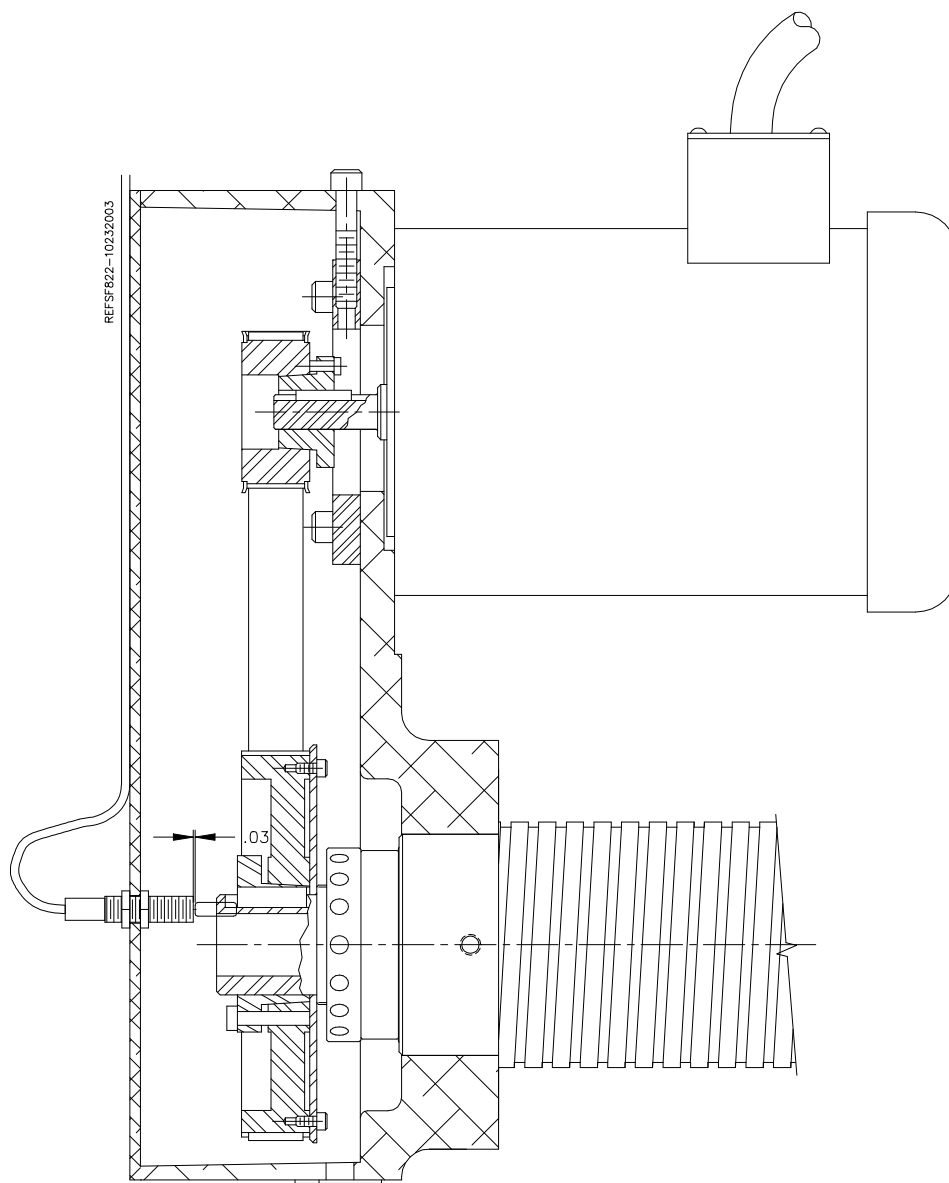

Horizontal Ball Screw and Belt Alignment and Adjustment:

- 1) The Way Covers do not need to be removed to align the ballscrew or adjust the belt tension. They can be accessed underneath the way covers at each end.
- 2) Move the spindle unit to the middle of it's travel.
- 3) Loosen the four mounting bolts on the Horizontal Motor Mount Plate.
- 4) Remove the belt.
- 5) Loosen the four mounting bolts on both of the ballscrew supports (one at each end).
- 6) Move the machine to the home position (all the way right). Tighten the four mounting bolts on the right hand ballscrew support.
- 7) Move the machine to it's full left hand travel. Tighten the four mounting bolts on the left hand ballscrew support.
- 8) Install the belt onto the ballscrew and motor pulleys. The motor mount bolts should still be loose at this point.
- 9) Let the weight of the motor tighten the belt. This is sufficient tension on the belt. Tighten the four motor mount bolts.

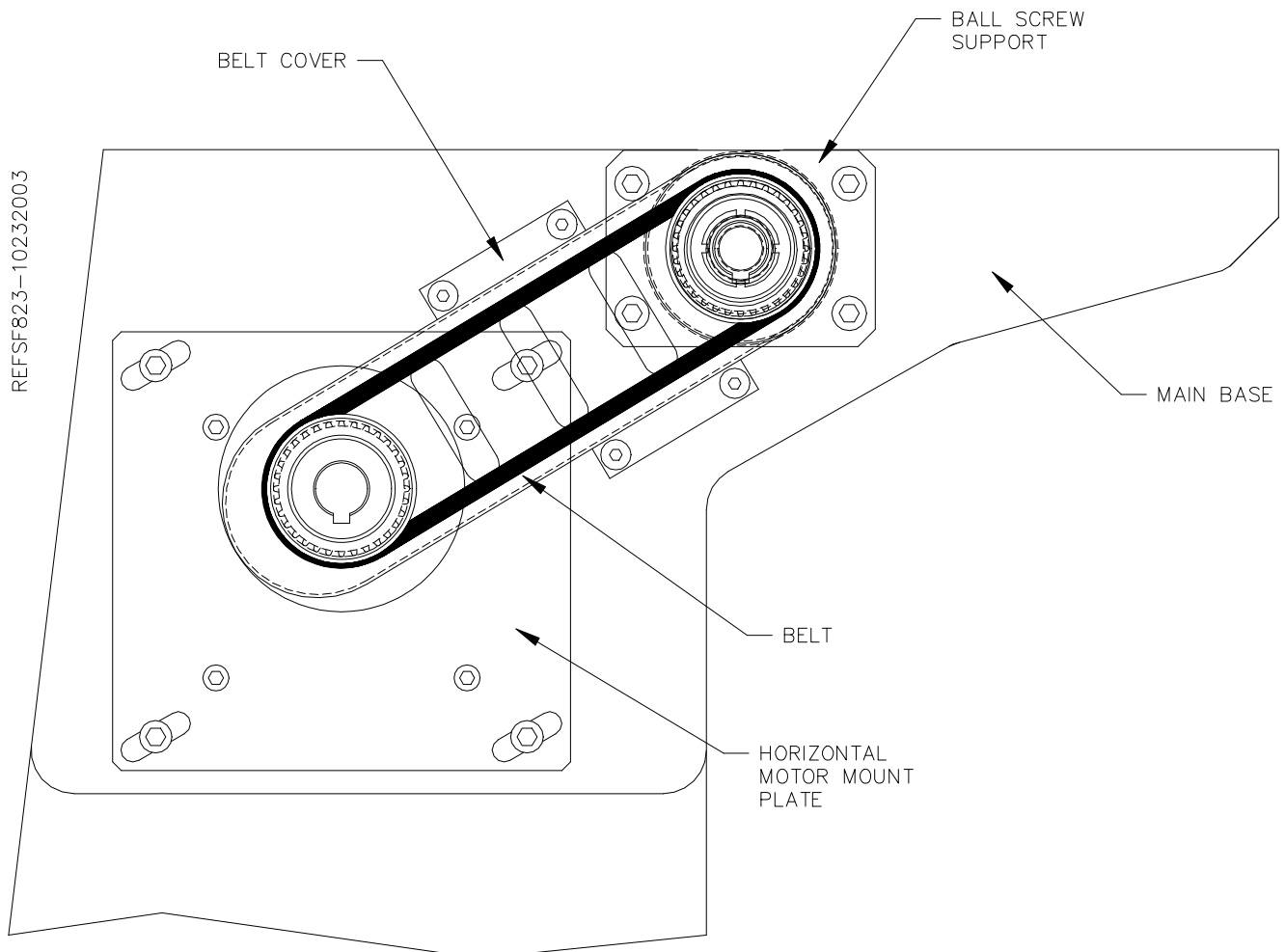

Air Adjustment of the SF7M – 8M Machine:

Up-Relief, Air Setting:

1. Press up / down adjust button.
2. Adjust, relief up air regulator, to 0 pressure.
3. Press relief up button.
4. Adjust relief up regulator pressure until the spindle lifts (Note air pressure reading).
5. Continue to adjust air pressure up until the vertical handwheel does not turn smoothly. (Note air pressure reading).
6. Set the regulator half way between these two readings.
7. This pressure should be approximately 50 to 60 psi.

Up / Down Adjust, Air Setting:

1. Press up / down adjust button.
2. Turn up / down adjust air regulator to 0 pressure.
3. Increase regulator pressure until vertical handwheel can be turned clockwise with moderate resistance. (Note air pressure reading.)
4. Continue to adjust air pressure up until the spindle will snap up into a relief position while the vertical handwheel is turned counter-clockwise vigorously. (Note air pressure reading.)
5. Set the regulator half way between these two readings.
6. This pressure should be approximately 9 to 15 psi.

Note: Maximum 20 psi

Relief Valve, Setting:

1. Note: up / down adjust, air setting, procedure must be completed first.
2. Press up / down adjust button.
3. Adjust relief valve clockwise until air is heard escaping. Then turn counter-clockwise until air just barely hisses out.
4. While viewing the up / down adjust, air regulator gauge, crank the vertical handwheel rapidly counter-clockwise several turns. (Note air pressure reading.) If the setting is correct there should be an increase of 5 to 7 psi.

Air Adjustments Illustration:

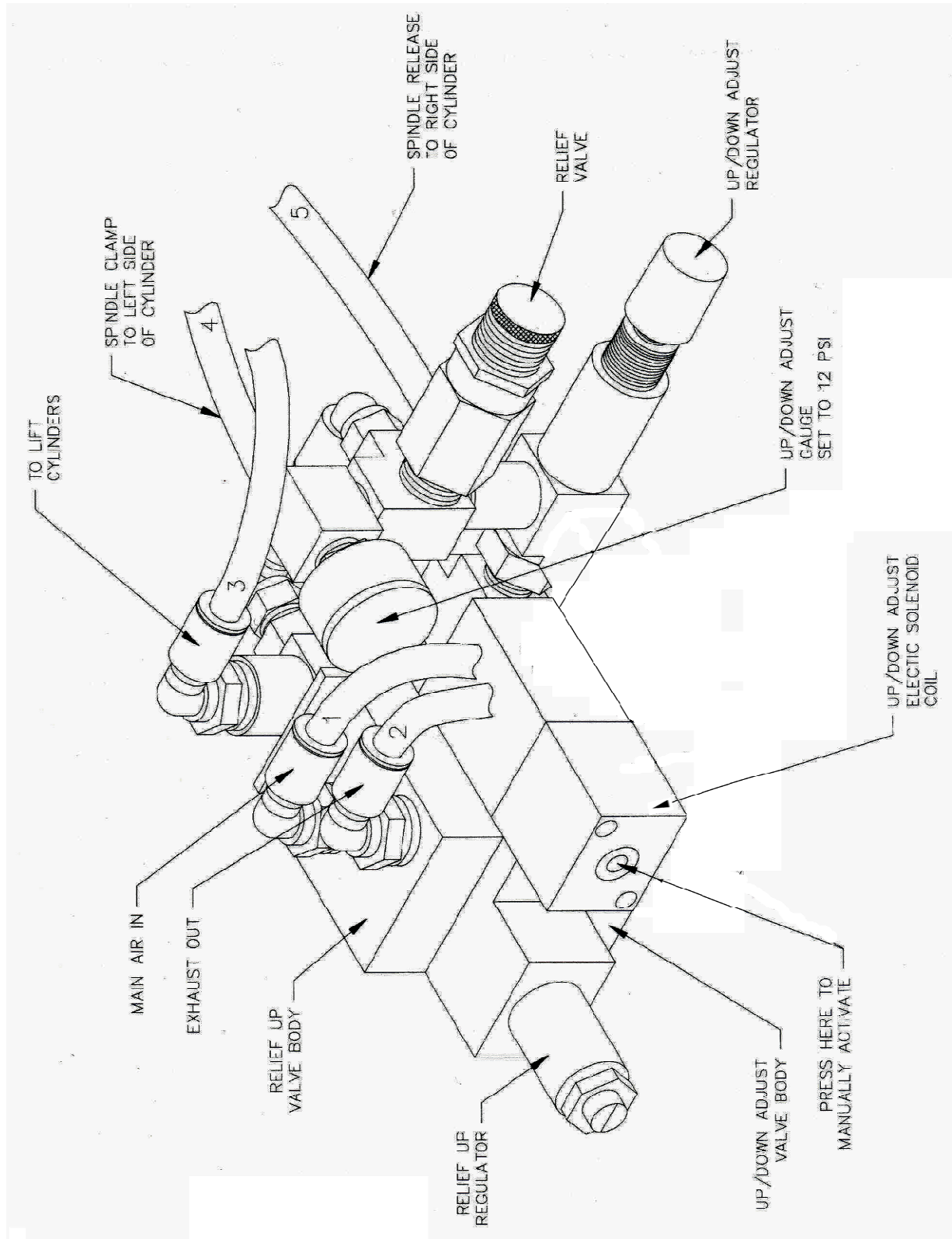

Pneumatic Control Diagram:

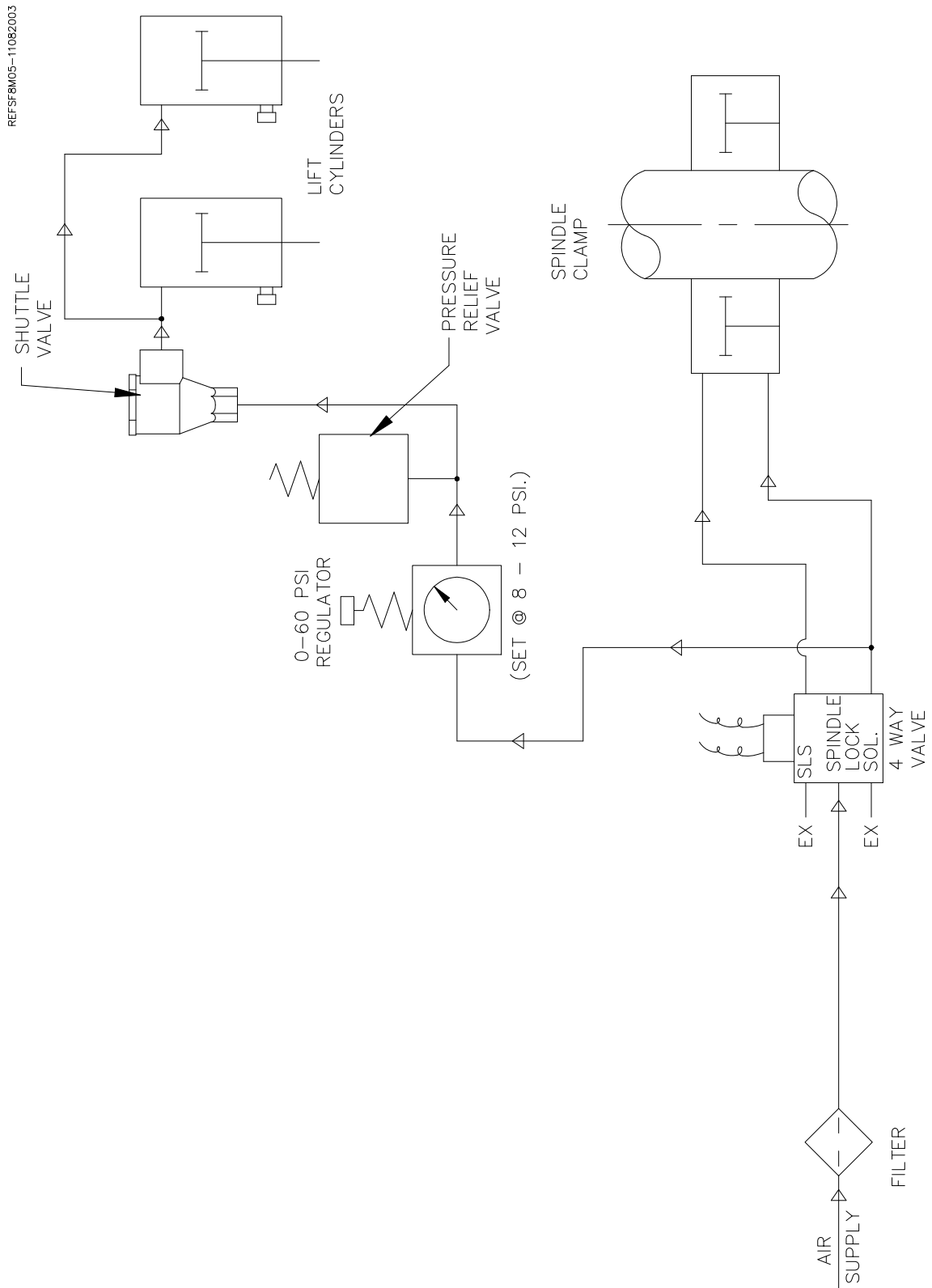

Cutterhead Tilt Adjustment:

Remove all work pieces, fixturing and parallels, from the lower surface of the main base. Travel the spindle unit over to the center of the main base.

▲ CAUTION Turn off all power to the machine before continuing.

Remove one tool holder from the cutterhead. Insert 7202J holder, fitted with a dial indicator, in the open tool holder slot. Using the handwheel, adjust the cutterhead down until you are in the middle of the dial indicator's range. The dial indicator will be indicating from the lower deck surface. Zero the dial indicator. Manually rotate the cutterhead clockwise. The left, leading edge, of the cutterhead should be .0025 to .004 inch lower than the right, trailing edge, of the cutterhead.

If the tilt is not within this tolerance, it will need to be adjusted. Loosen the six allen head bolts holding the 7004D bushing to the bottom of the spindle base. (See illustration on page 5.8) Snug the bolts up very lightly.

Use the three set screws, located just above the lower bushing, near the lower edge of the spindle base, to move the bushing for the proper tilt. If the spindle needs to tilt to the left, loosen the left set screw and tighten the right, the opposite is true if the tilt needs to be to the right.

Tighten the six allen head bolts firmly, Snug all set screws to prevent them from backing out.

Recheck tilt with dial indicator to be sure it is correct.

Remove the indicator holder from the cutterhead. Replace tool holder. Turn the power back on and operate normally.

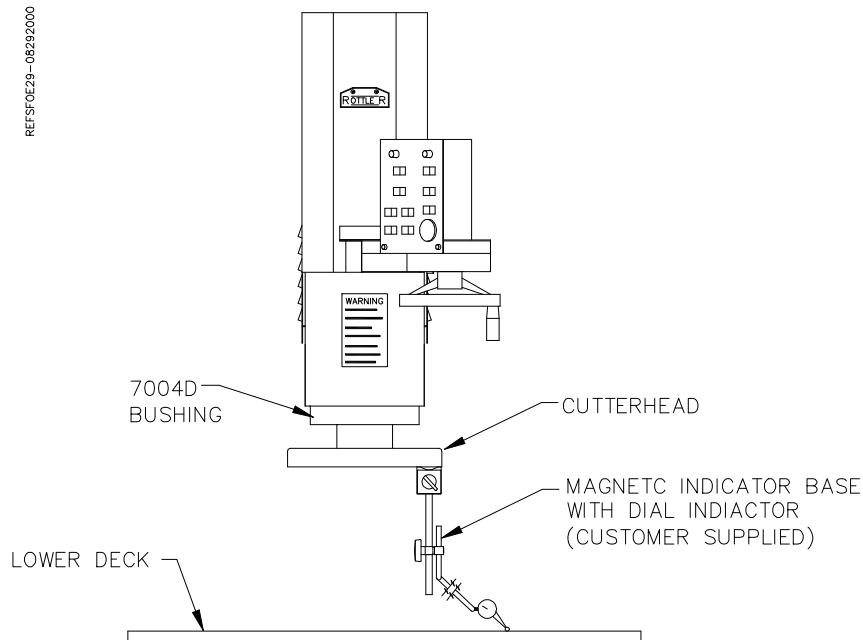

Inner Spindle Adjustment:

CAUTION

Turn off all power to the machine before continuing.

Remove the two screws holding the small nameplate (502-1-19C) to the front of the upper housing. Inside the exposed opening is the spindle adjustment nut (7020). The spindle adjustment nut has holes drilled around its perimeter to accept an adjustment rod.

Insert an adjustment rod into the spindle adjustment nut. The adjustment rod should be 1/4 - 5/16 inch diameter and 8 to 10 inches long.

Carefully rotate the cutterhead counter-clockwise, (looking from above the cutterhead) letting the adjustment rod move against the end of the slot. This tightens the inner spindle adjustment. The cutterhead will be easy to turn and you should be able to feel the spring loaded detent in the adjustment nut.

At some point the torque required to turn the cutterhead will sharply increase, immediately stop turning the cutterhead.

CAUTION

Do not over tighten or severe bearing damage will occur.

Turn the cutterhead clockwise one or two detents.

Remove the adjustment rod and replace the nameplate

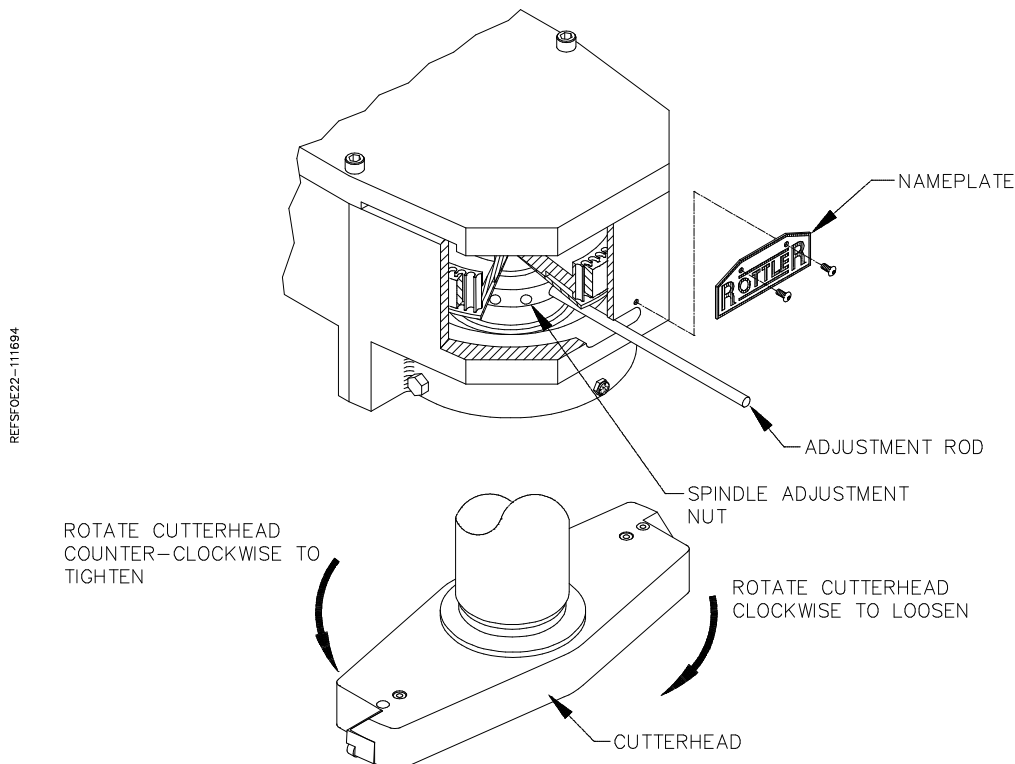

Chapter 5 Troubleshooting:

Chapter 6 Machine Parts:

Front / Right Side View SF8M:

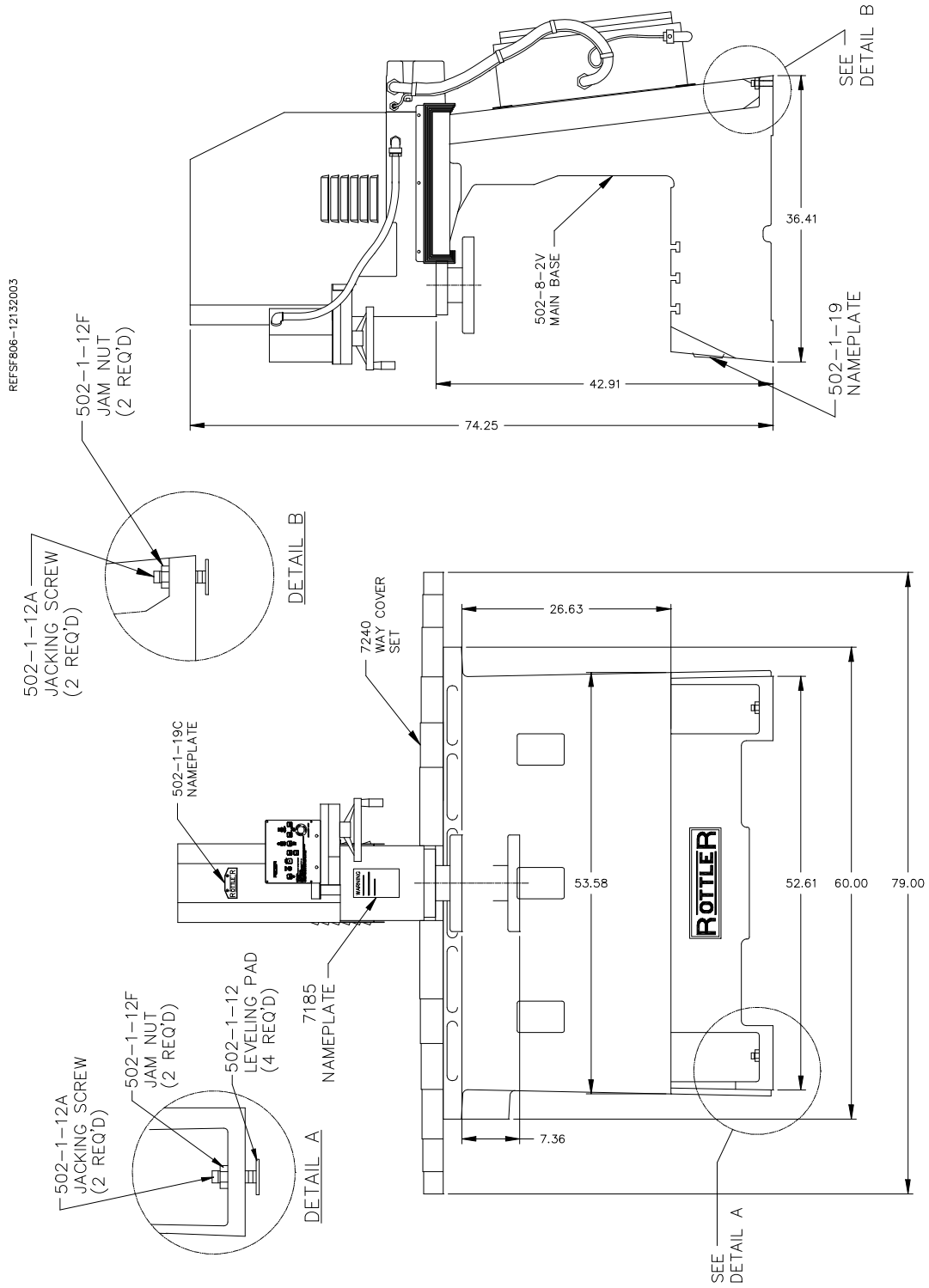

Front / Right Side View SF7M:

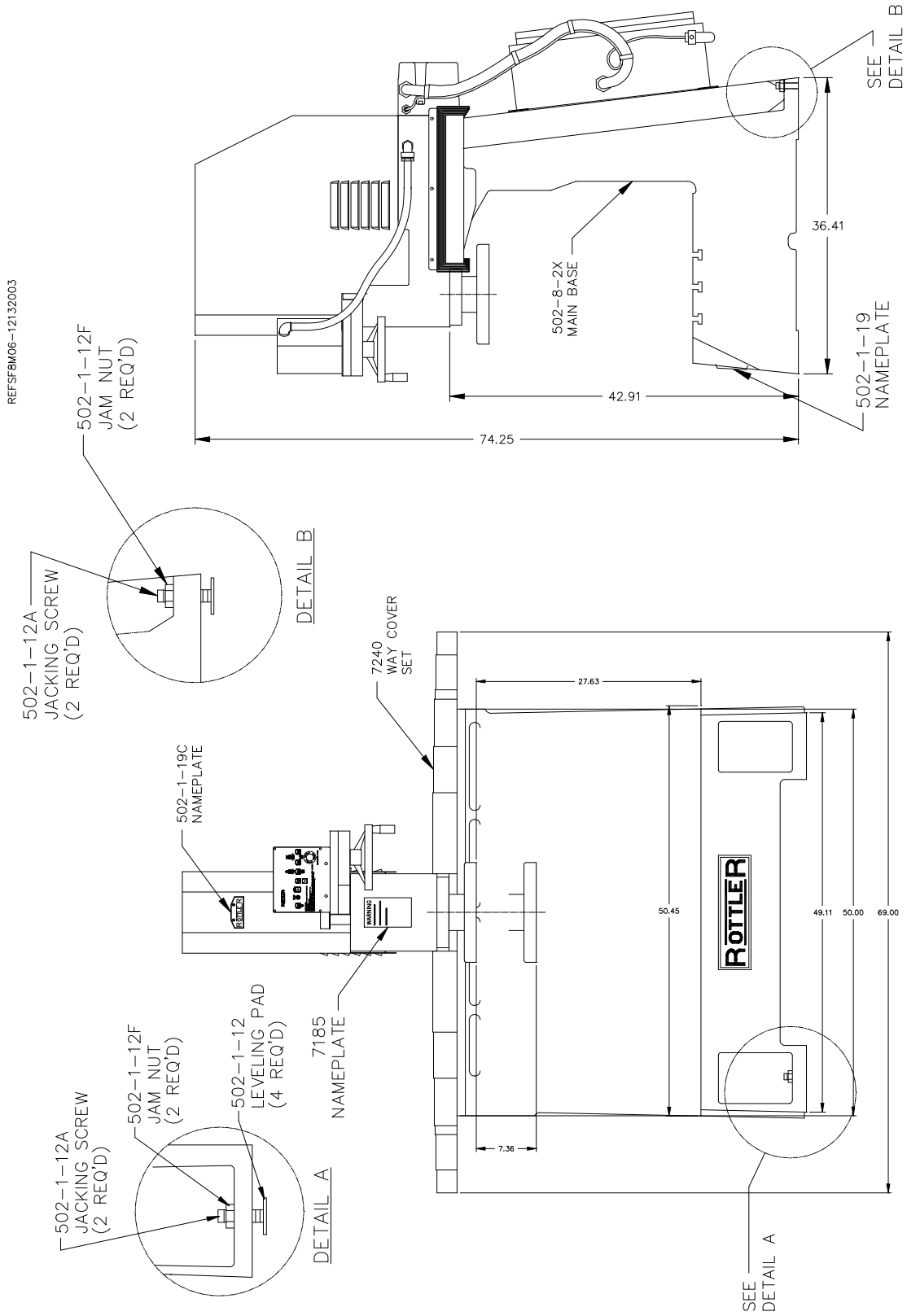

Pneumatic Assembly:

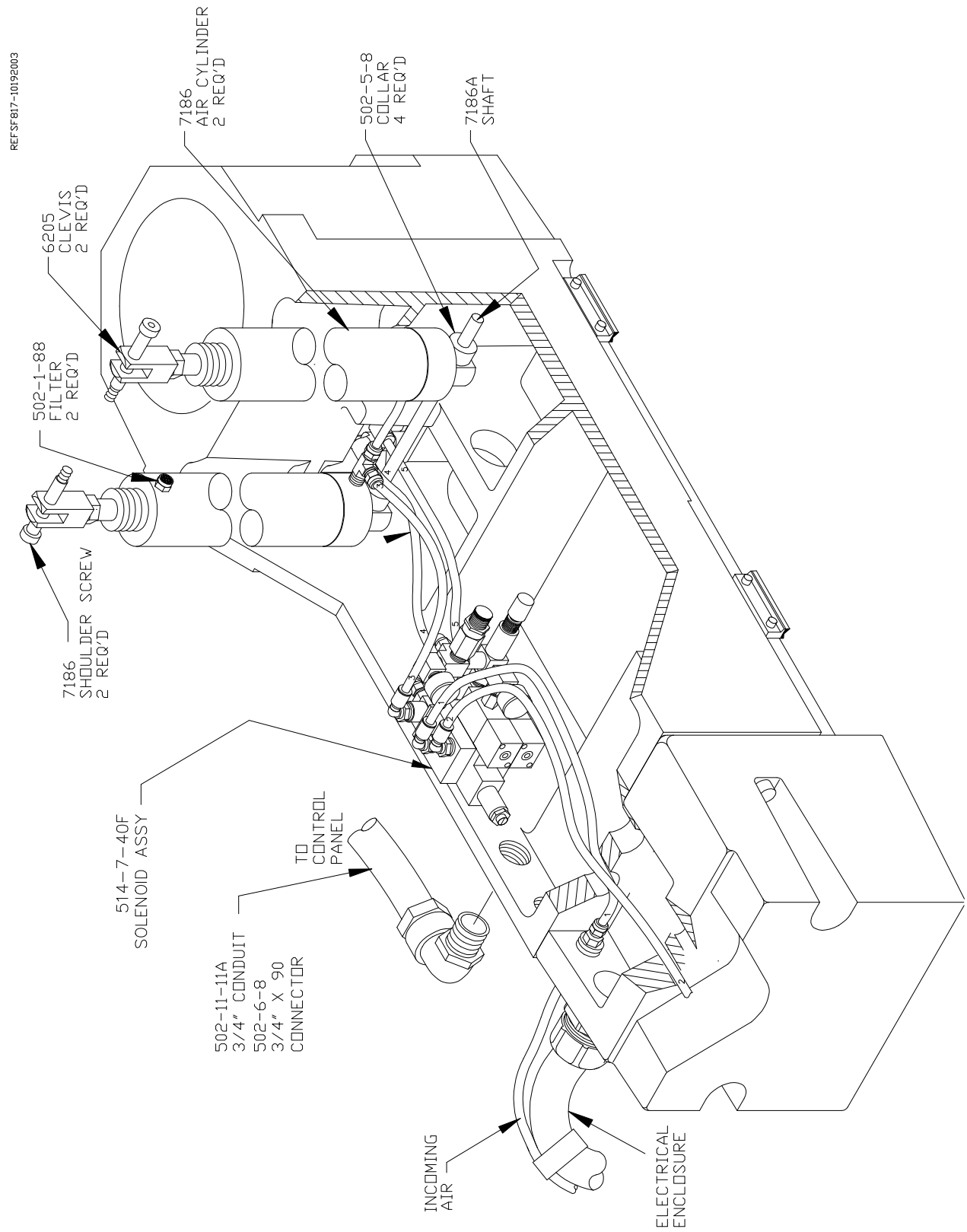

Solenoid Assembly:

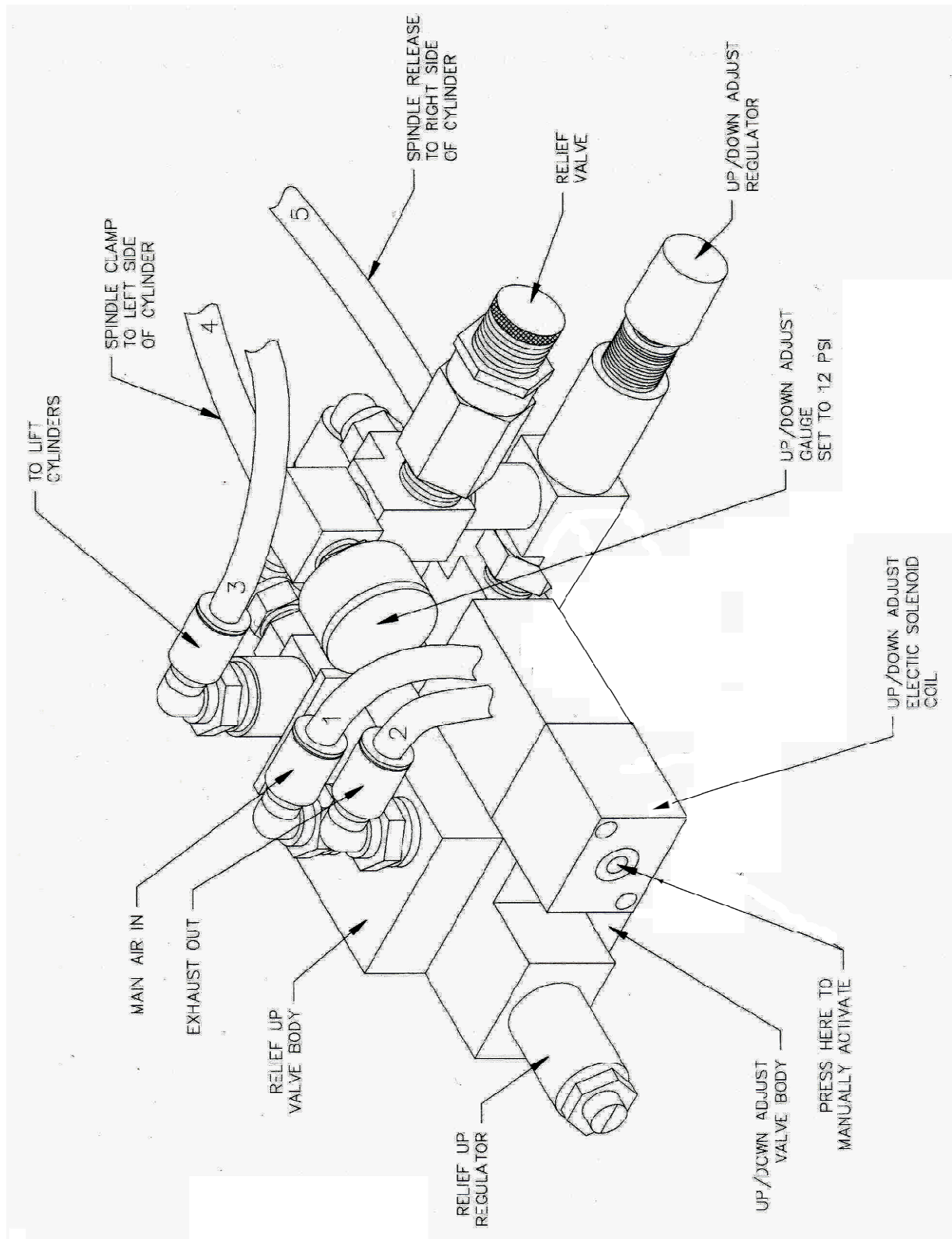

Electrical Enclosure:

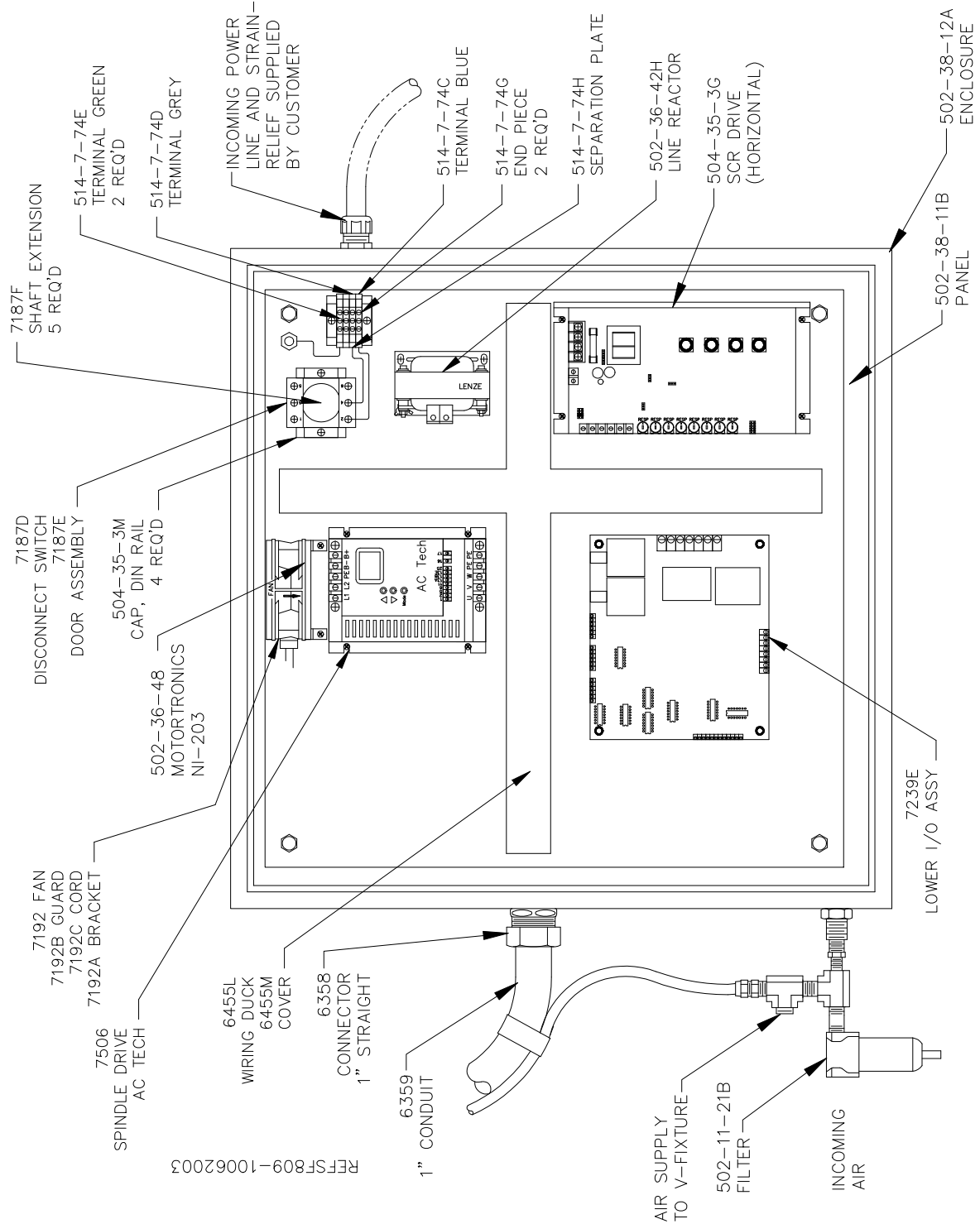

Upper Housing:

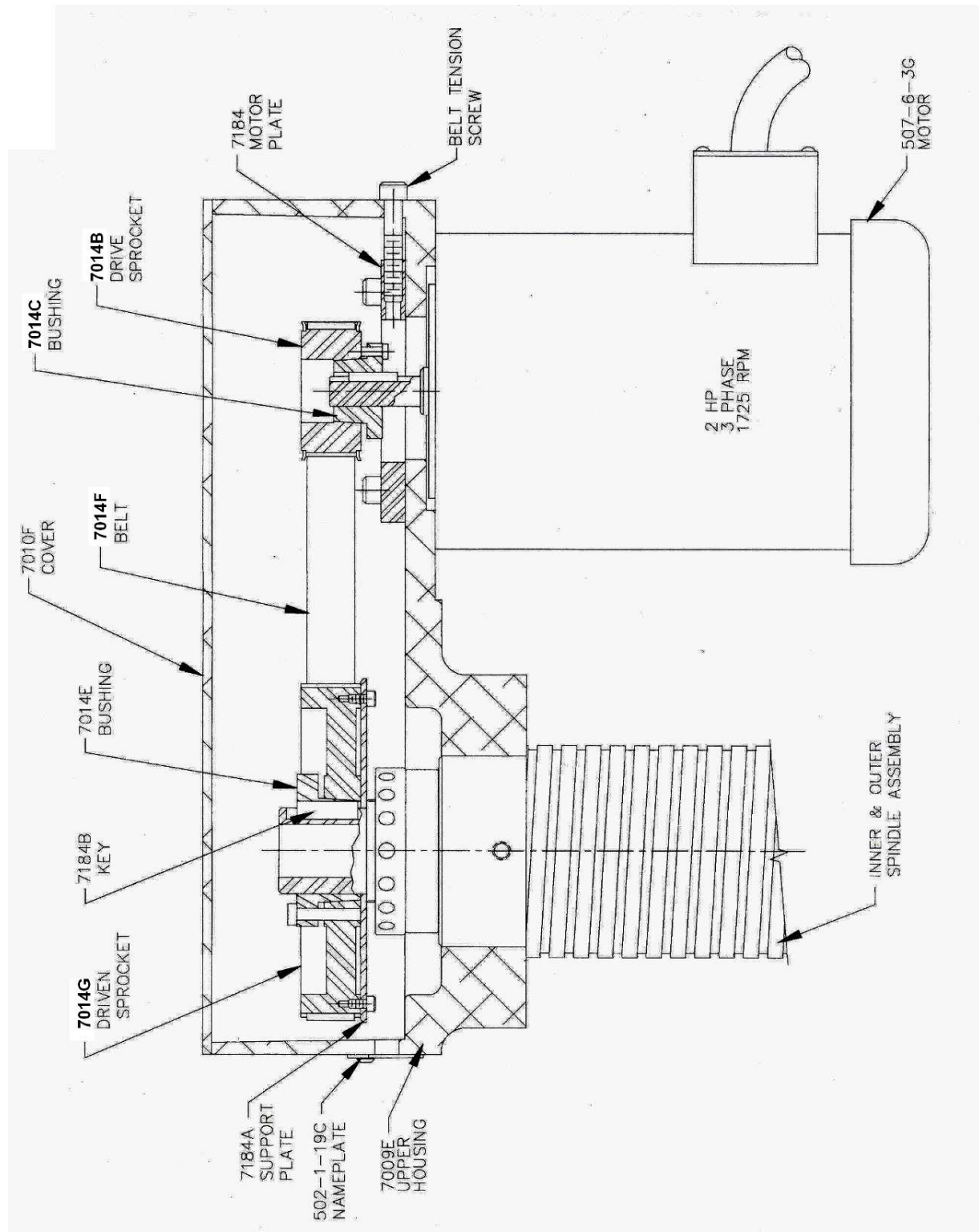

Vertical Adjustment (Chain):

REFSF811-10072003

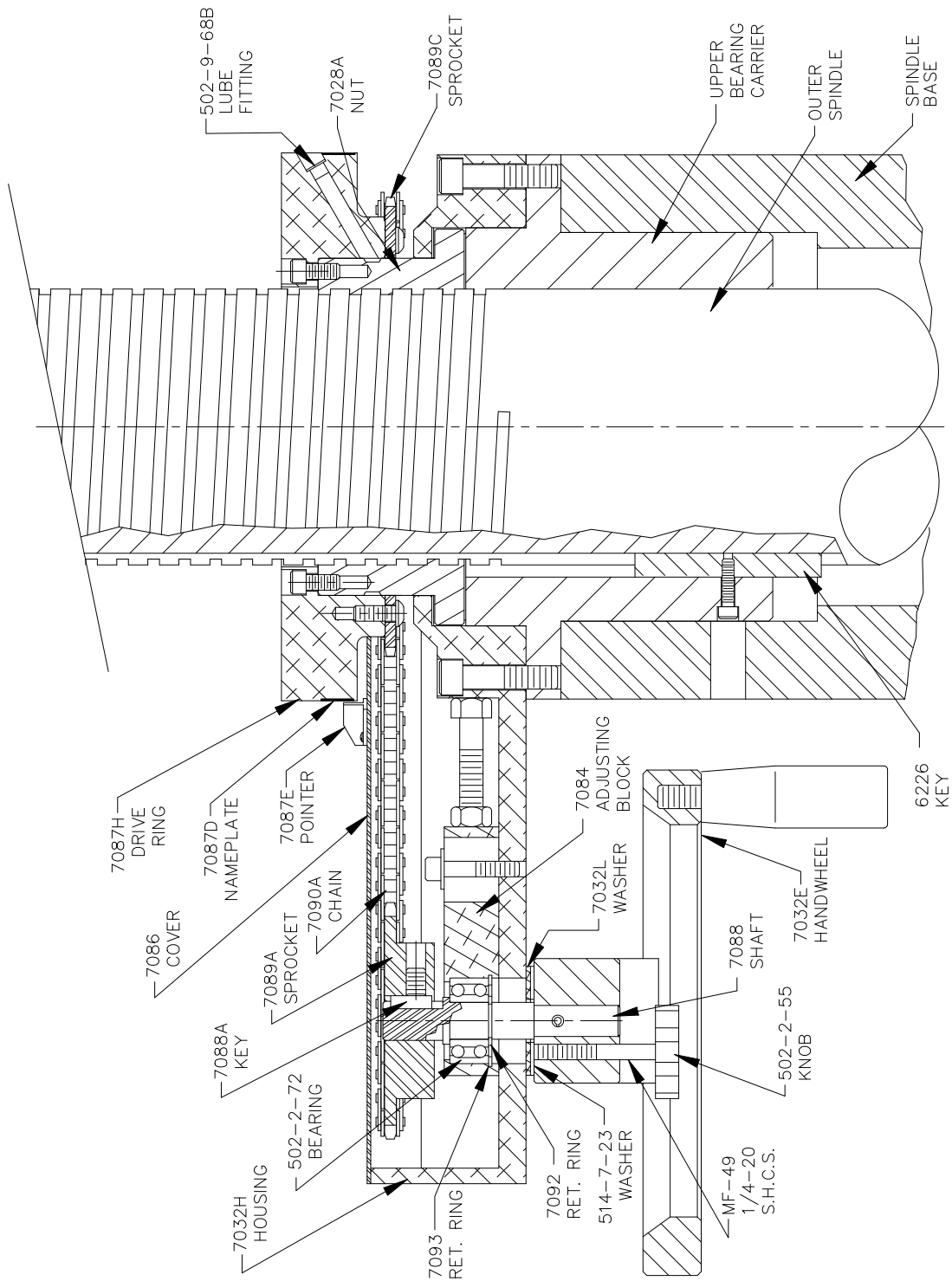

Spindle Base Front Section:

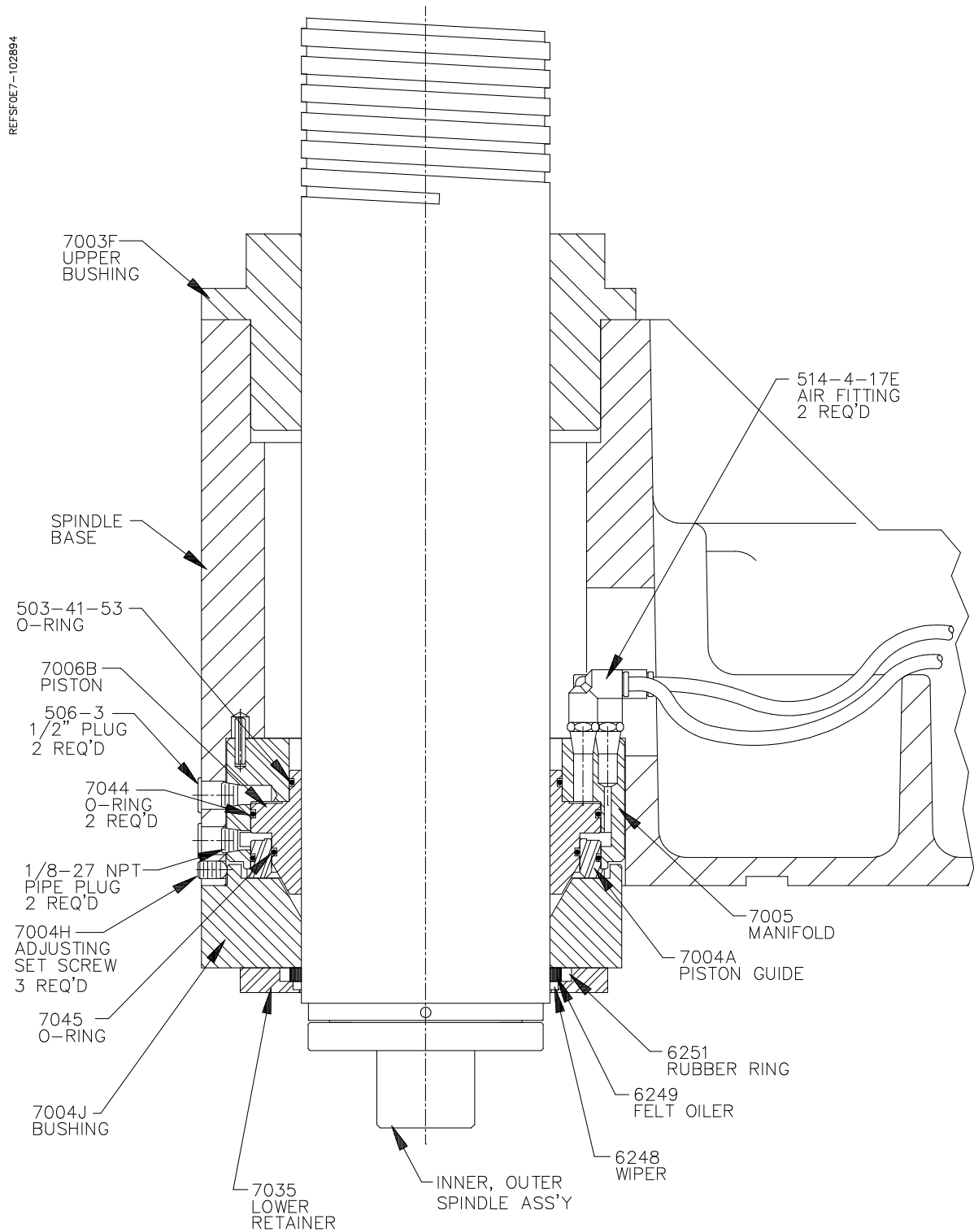

Inner / Outer Spindle Assembly:

REFSF0E8-111694

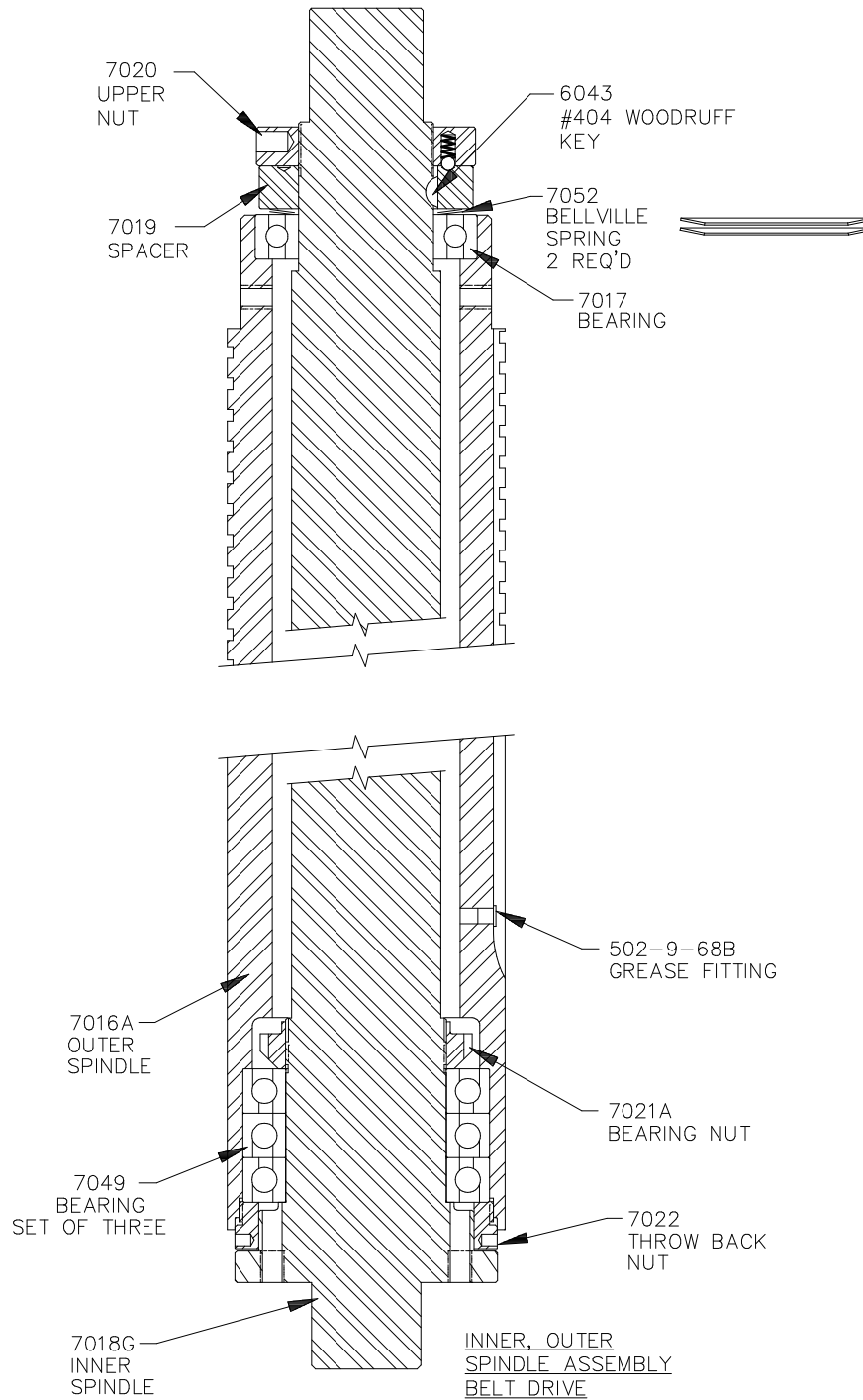

Spindle Base Assembly:

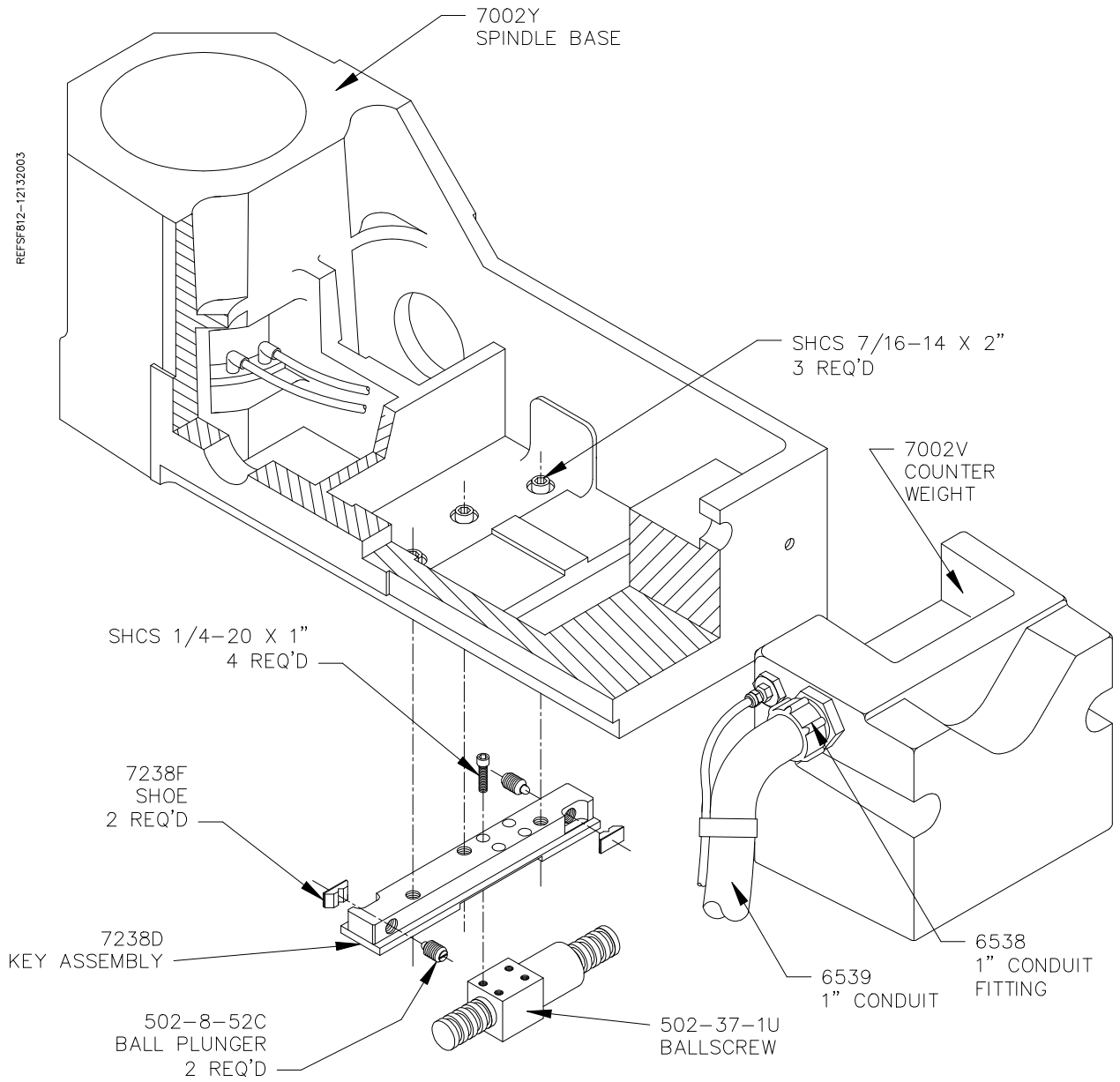

Left Ballscrew Support:

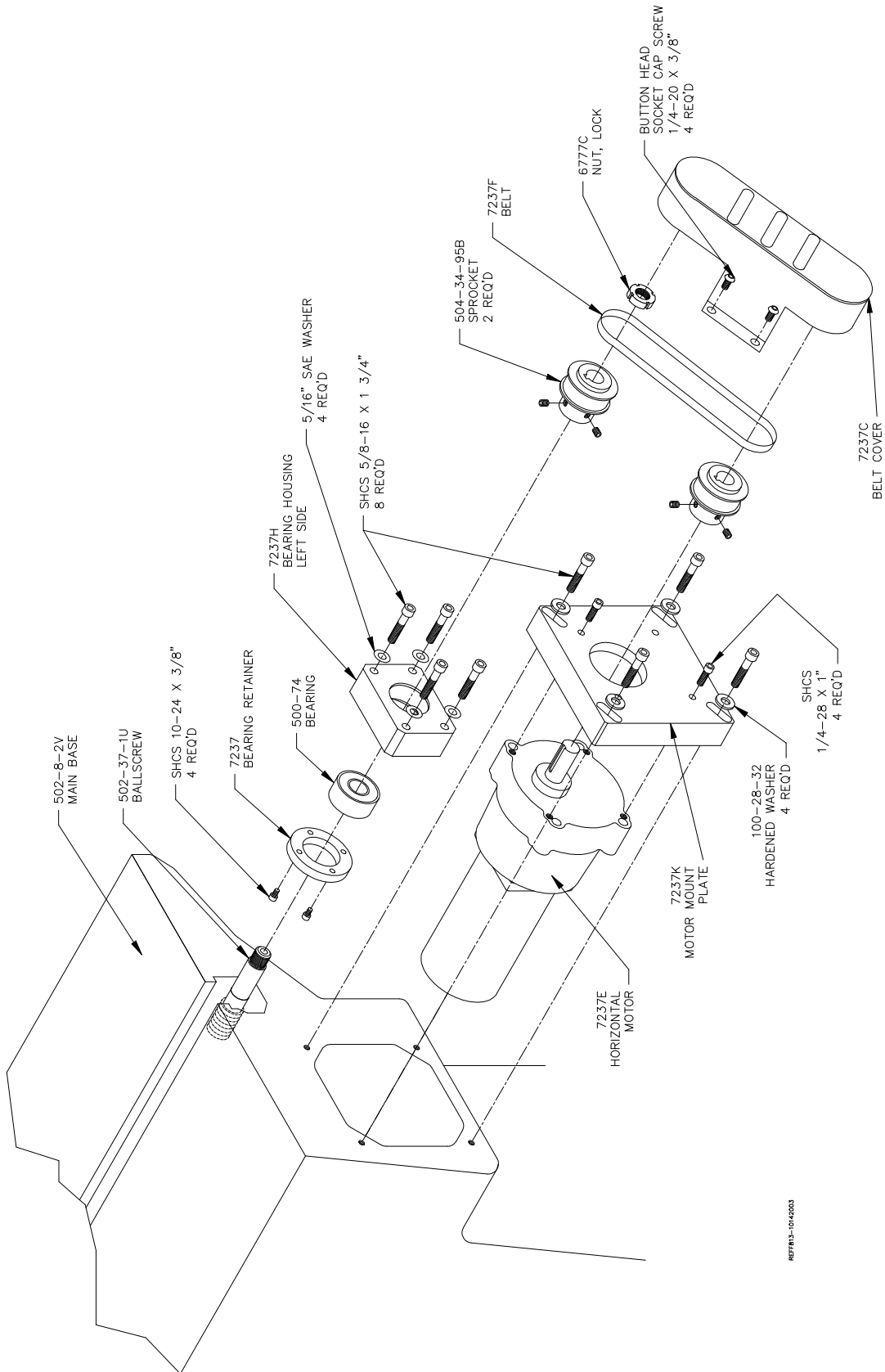

REFR13-1014203

Right Ballscrew Support:

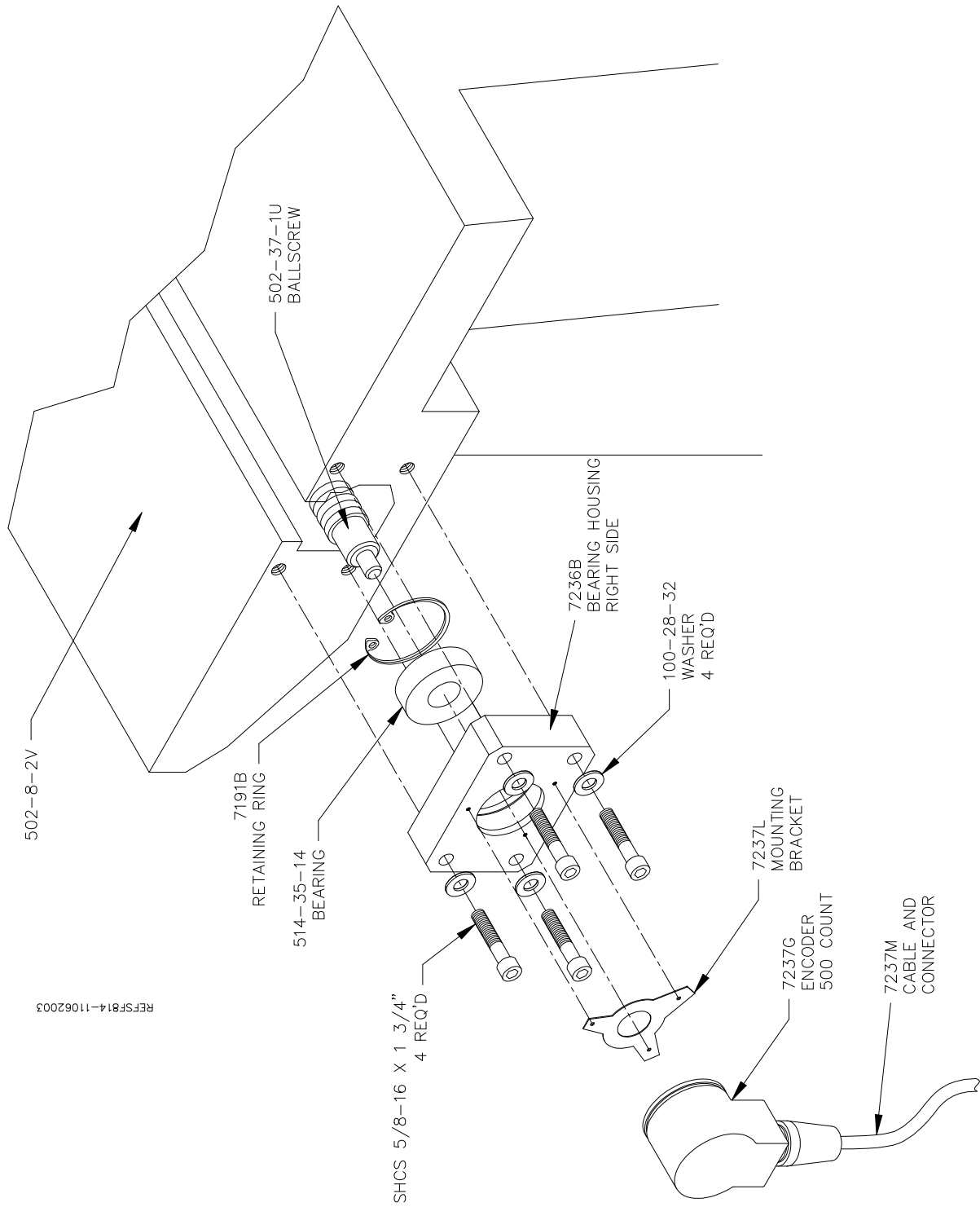

Home and Limit Switches:

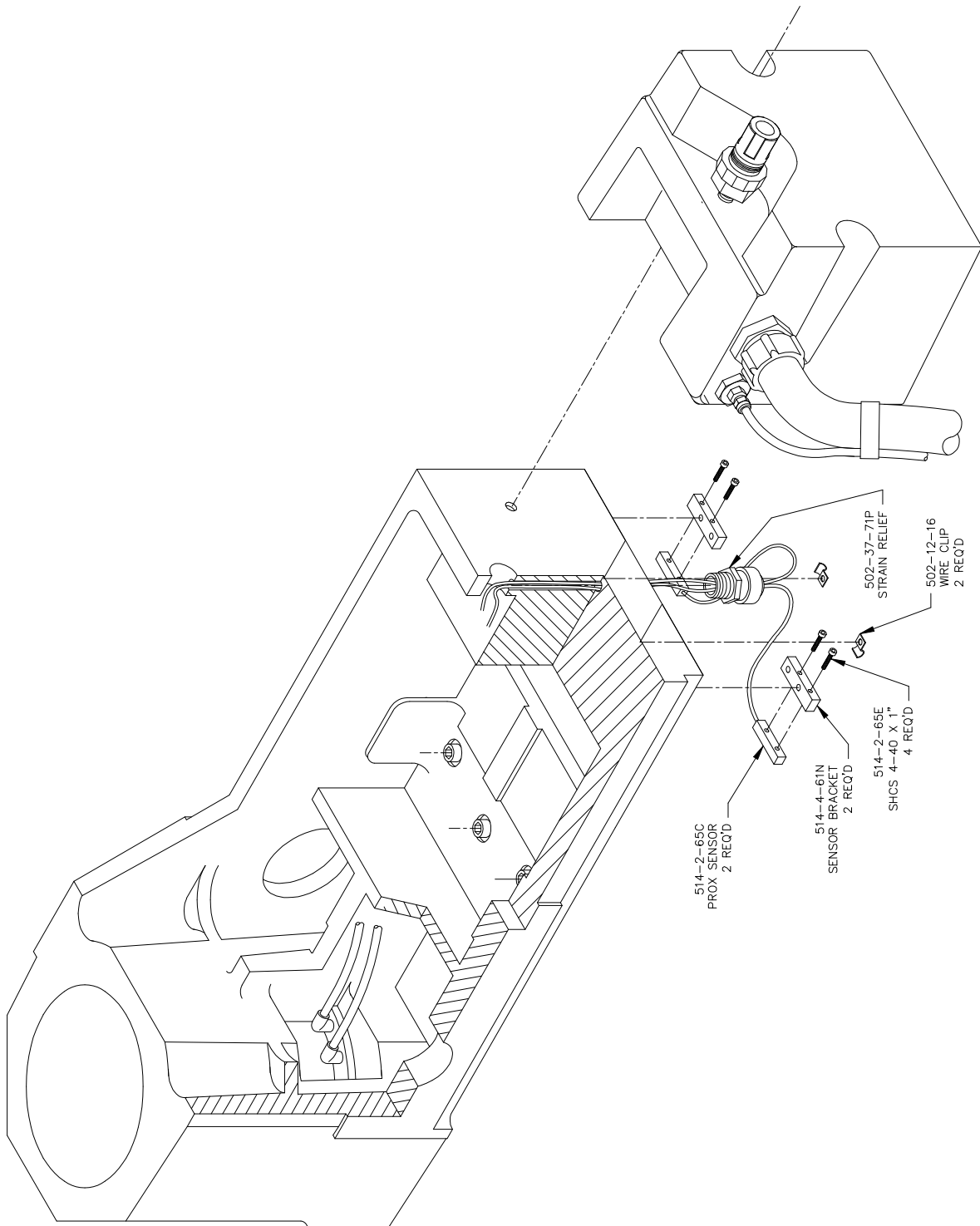

REFSF815-10172003

Pendant Assembly:

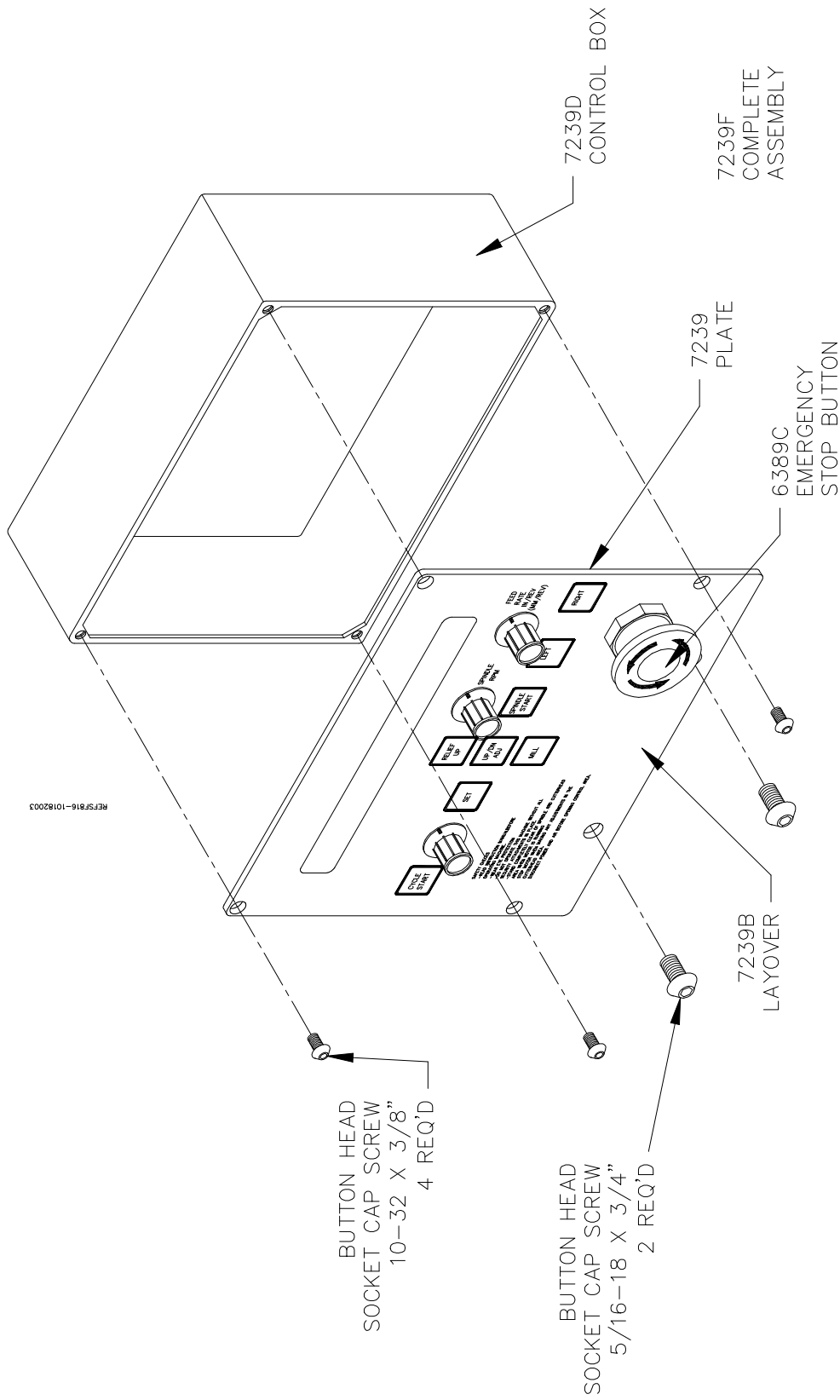

Spindle Base:

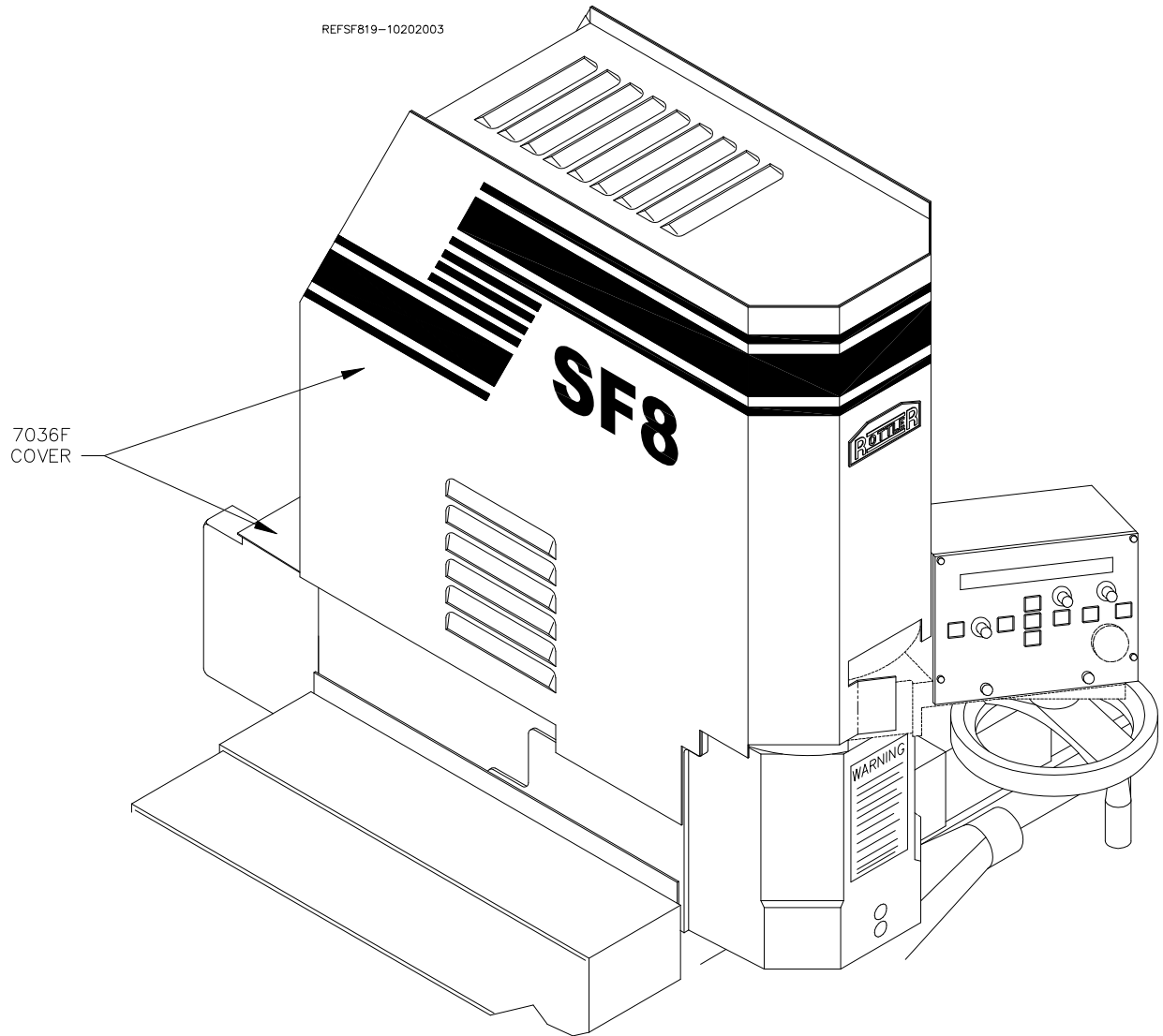

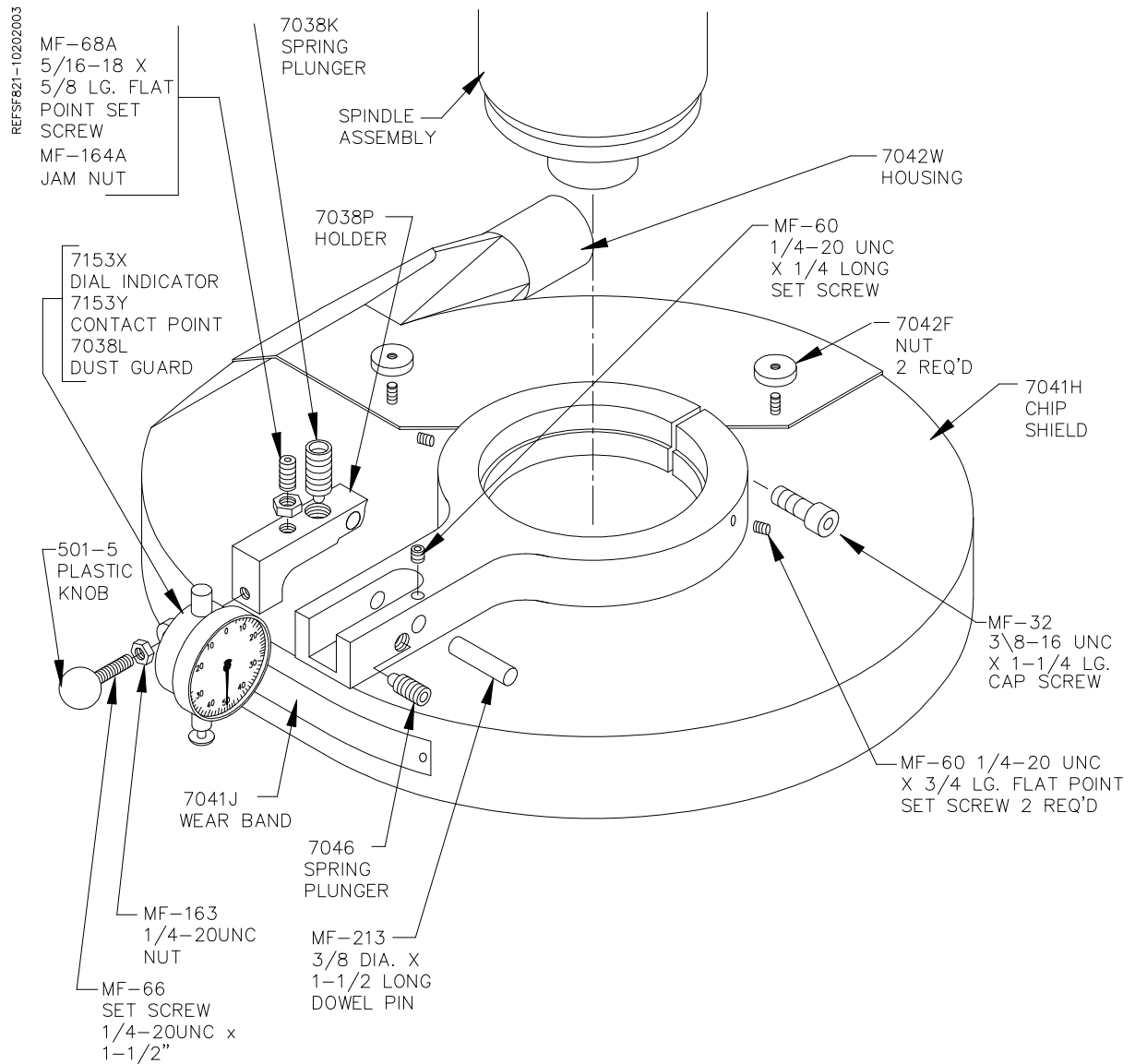
Chip Shield:

14" Fly Cutter:

REFSFOE28-08142000

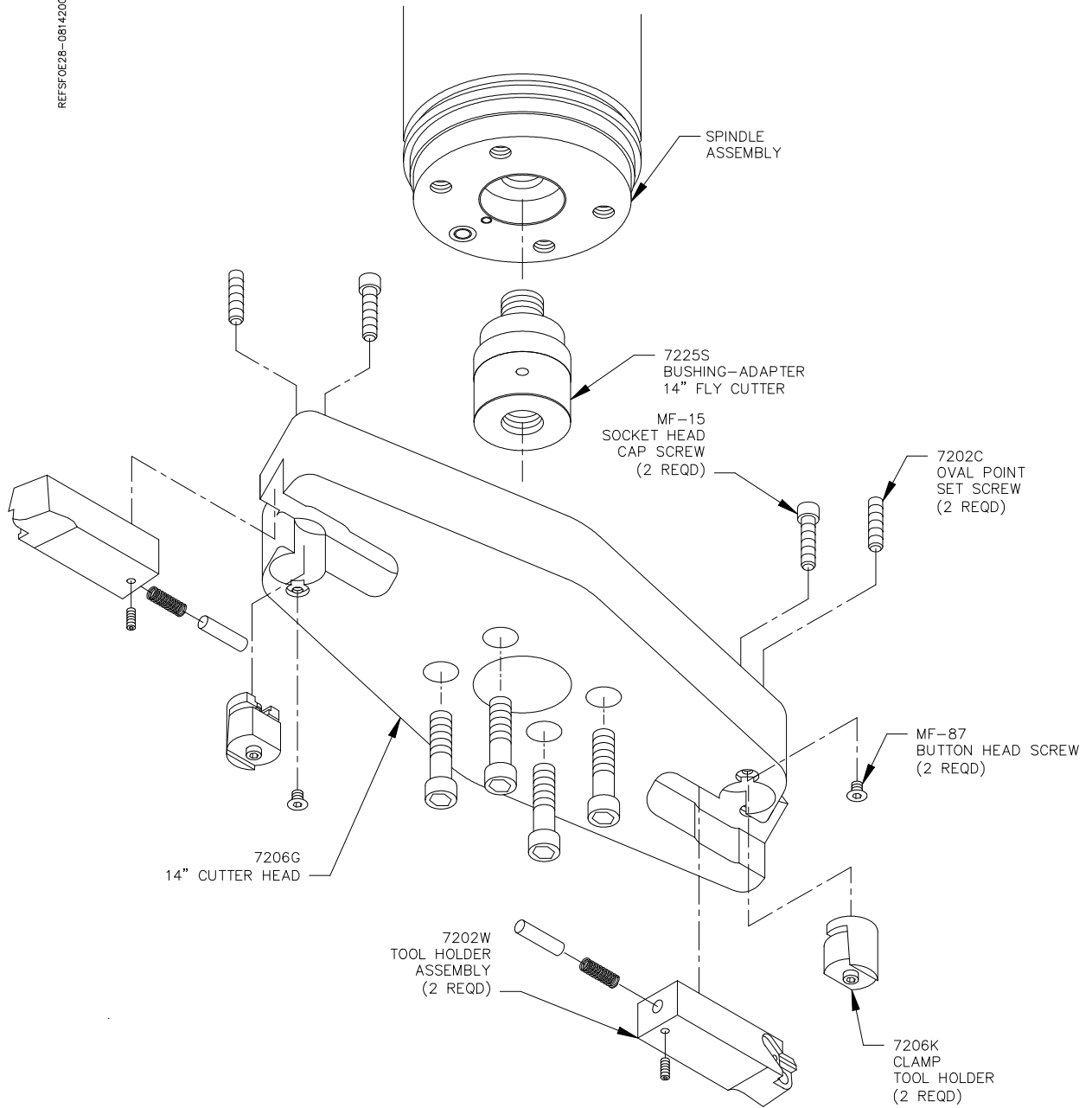

Riser Set:

