



H86A OPTIONAL EQUIPMENT PARTS MANUAL



ORDERING PROCEDURE

Contact your regional Rottler sales rep for assistance in ordering optional equipment, replacement parts, or tooling.

If you are unable to contact your regional Rottler sales rep, call the factory at 253-872-7050 and ask to speak to the parts sales specialists.

Have the following information handy to expedite the ordering process:

1. Your name, business name, and contact number
2. Customer number
3. If you don't have a customer number, your billing address
4. Shipping address if different from billing address
5. Machine model and serial number
6. Part number and description of what you want to order
7. Preferred method of shipment

You may also contact us via e-mail with the above information. Send e-mail requests to: parts@rottlermfg.com

In some cases you may be requested to send a photo of the part you are ordering if it is a replacement part, or doesn't appear in the database.

If you are unsure which part you need to order, contact our service department and ask to speak to one of our service consultants. They will assist you in determining which part you require.

THERE IS A MINIMUM ORDER OF \$25.00

Contents

Optional Fixturing.....	1
514-7A Manual Indexable Roll Over Fixture Parts.....	1
514-7-14E 2" 50.8mm Small Diameter Main Line Bar.....	4
502-1-30H Clamp Arm Assembly Parts.....	4
11115 2" (50mm) X 3" (75mm) Parallels.....	5
11112 Universal 8" (203mm) Heavy Duty T-Slot Parallels Parts.....	6
11114 Universal 16" (405mm) Heavy Duty T-Slot Parallels Parts.....	8
Fixture for Honing Multiple Cylinder Liners (4 Liners).....	10
514-11-5 Cylinder Liner Honing Fixture Parts.....	10
514-11-6 Fixture Plate Parts.....	11
514-11-7 Fixture Plate Parts.....	11
514-11-4 Fixture Plate Parts.....	12
Optional Coolant and Filter Equipment.....	13
514-4-71C Synthetic Coolant.....	13
514-4-71D Coolant Refractor.....	13
514-2-42C Dual Gradient 50-5 Micron Replacement Filter Cartridge.....	14
514-2-42A Cannister Magnetic Filter System.....	14
Optional Rottler Precision Hone Heads, Sleeves and Stone Holders.....	15
514-9J Medium Rottler Precision 4 Stone Holder Hone Head Assembly Parts.....	15
514-10-13 Series Stone Holder Parts.....	16
Medium Hone Head Stone Size Charts.....	16
514-9Q Large Rottler Precision Heavy Duty 6 Stone Holder Hone Head Assembly Parts.....	18
514-9S Large Rottler Precision Heavy Duty 6 Stone Holder Hone Head Assembly Parts.....	19
514-9-4E Sleeve Assembly Parts.....	20
514-9-4F Sleeve Assembly Parts.....	20
514-9-4G Sleeve Assembly Parts.....	21
514-9-31 Series Stone Holder Parts.....	22
Six Stone Hone Head Stone Size Chart.....	22
Diamond Abrasives for Rottler Precision 6 Stone Holder Hone Heads.....	25
514-9-32F Diamond Stones, 80 grit.....	25
514-9-32R Diamond Stones 80 grit.....	25
514-9-32W Diamond Stones, 140/170 grit.....	25
514-9-32K Diamond Stones, 170/200 grit.....	25
514-9-32J Diamond Stones, 270/325 grit.....	26

514-9-32E Diamond Stones, 325/400 grit.....	26
514-9-33K Diamond Stones, 325/400 grit	26
514-9-32C Diamond Stones, 500 grit	26
514-9-32L Diamond Stones, 550 grit.....	26
514-9-32G Diamond Stones, 600 grit	27
514-9-33 Diamond Stones, 800 grit	27
514-9-33C Diamond Stones, 800 grit	27
514-9-33J Diamond Stones, 1200 grit.....	27
514-9-33B Diamond Stones, 270/325 grit	28
514-9-32D Diamond Stones, 325/400 grit	28
514-9-33A Diamond Stones, 800 grit	28
514-9-35C CBN Stones, 320 grit.....	29
514-9-35D CBN Stones, 400 grit.....	29
514-9-35B CBN Stones, 600 grit.....	29
514-9-14H Brushes, for Plateau Finishing.....	29
514-9-14Y Brushes, for Plateau Finishing.....	29
514-9P Large Rottler Precision Heavy Duty 4 Stone Holder Hone Head Assembly Parts.....	30
514-9R Large Rottler Precision Heavy Duty 4 Stone Holder Hone Head Assembly Parts	31
514-9-4A Sleeve Assembly Parts	32
514-9B Sleeve Assembly Parts	32
514-9-4G Sleeve Assembly Parts	33
514-9-6 Series Stone Holder Parts.....	33
514-9-6 Series Stone Holder Size Chart	34
514-9-14F Diamond Stones, 80 grit.....	35
514-9-14R Diamond Stones, 80 grit	35
514-9-14W Diamond Stones, 140/170 grit.....	35
514-9-14K Diamond stones, 170/200 grit.....	35
514-9-14M Diamond Stones, 170/200 grit.....	36
514-9-14J Diamond Stones, 270/325 grit.....	36
514-9-14T Diamond Stones, 270/325 grit.....	36
514-9-14Z Diamond Stones, 270/325 grit.....	36
514-9-14E Diamond Stones, 325/400 grit.....	36
514-9-14Q Diamond Stones, 325/400 grit	37
514-9-14X Diamond Stones, 325/400 grit.....	37
514-9-14V Diamond Stones, 400 grit.....	37



514-9-14C Diamond Stones, 500 grit 37

514-9-14P Diamond Stones, 500 grit..... 37

514-9-14D Diamond Stones, 325/400 grit 38

514-9-14U Diamond Stones, 500 grit 38

514-9-14L Diamond Stones, 550 grit..... 38

514-9-14N Diamond Stones, 550 grit 38

514-9-14G Diamond Stones, 600 grit 38

514-9-14S Diamond Stones, 600 grit..... 39

514-9-21G Diamond Stones, 800 grit 39

514-9-21H Diamond Stones, 1000 grit 39

514-9-21J Diamond Stones, 1200 grit..... 39

514-9-35C CBN Stones, 320 grit..... 40

514-9-35D CBN Stones, 400 grit..... 40

514-9-35B CBN Stones, 600 grit..... 40

514-9-14H Brushes, for Plateau Finishing..... 41

514-9-14Y Brushes, for Plateau Finishing..... 41

514-9F Extra Large Precision Heavy Duty 4 Stone Holder Hone Head Assembly Parts 42

514-9-4D Sleeve Assembly Parts 44

514-9-25 Series Stone Holder Parts 44

514-9-25 Series Stone Holder Size Chart 45

514-9N Hone Head, Single Stage (12 Stone)..... 46

110-171-01 Single Stage Diamond Stones 47

110-171-02 Single Stage Diamond Stones 47

110-171-03 Single Stage Diamond Stones 47

LO-6568-161 Hone Head, Single Stage (6 Stone) 48

110-174-01 Diamond Stones 48

LO-6568-160 Hone Head, Single Stage..... 49

110-173-01 Diamond Stones 49

514-9-18P Special Red Finish Diamonds 50

514-9-18N Silicone Abrasive Exposing Stones 50

514-9-21 Polishing Felt Pads 50

514-9-21F Silicone Paste..... 50

Optional Measuring Equipment 51

201 Mitutoyo Surface Tester Surftest 201 51

514-8-27 Stone Depth Scale and Holder Assembly (inch) 51



514-8-27F Stone Depth Scale and Holder Assembly (metric) 51
Adapter for Pin Honing Mandrels 52
514-9V Adapter Parts 52

Optional Fixturing

514-7A Manual Indexable Roll Over Fixture Parts

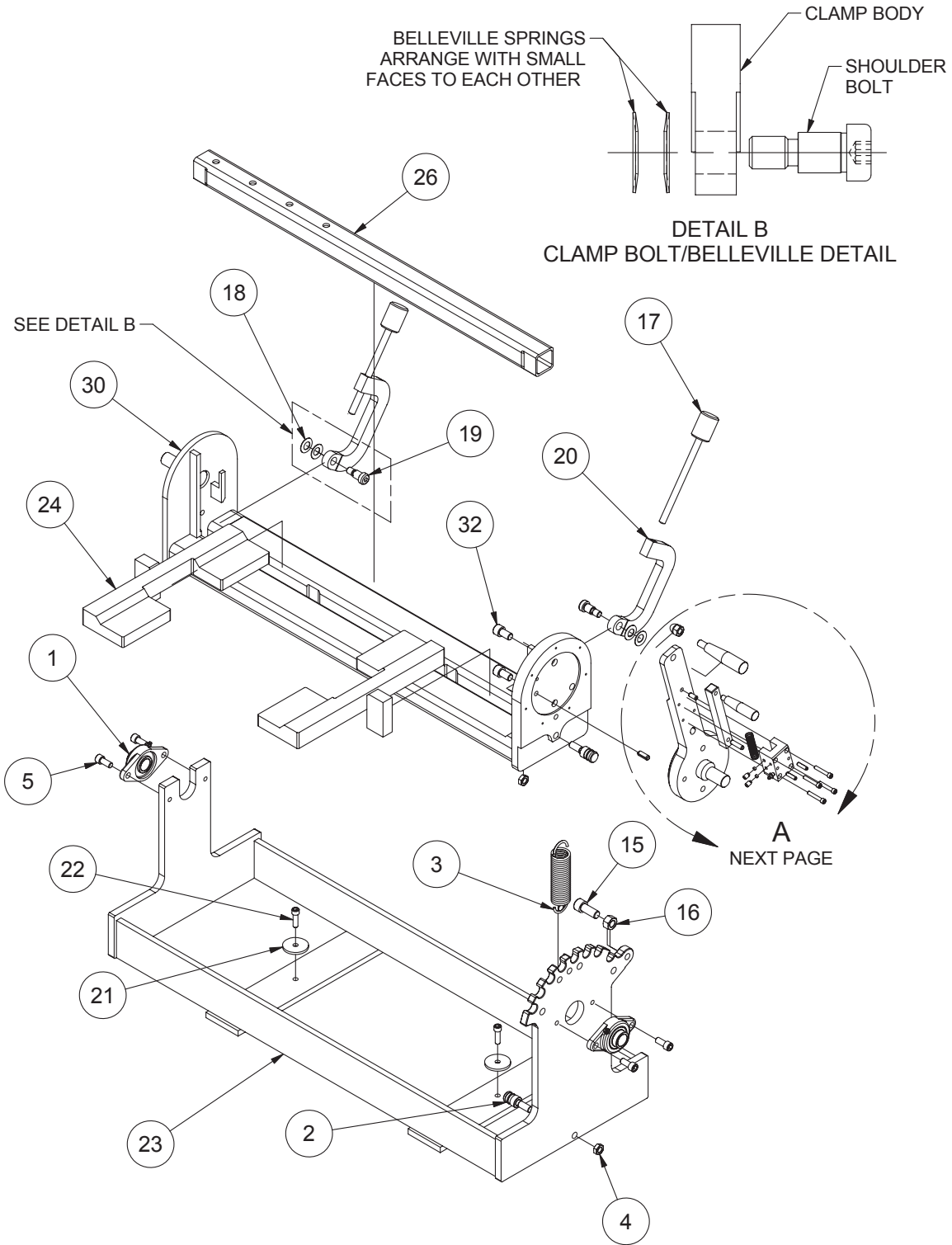

514-7A
BLOCK HOLD DOWN FIXTURE
ASSEMBLY

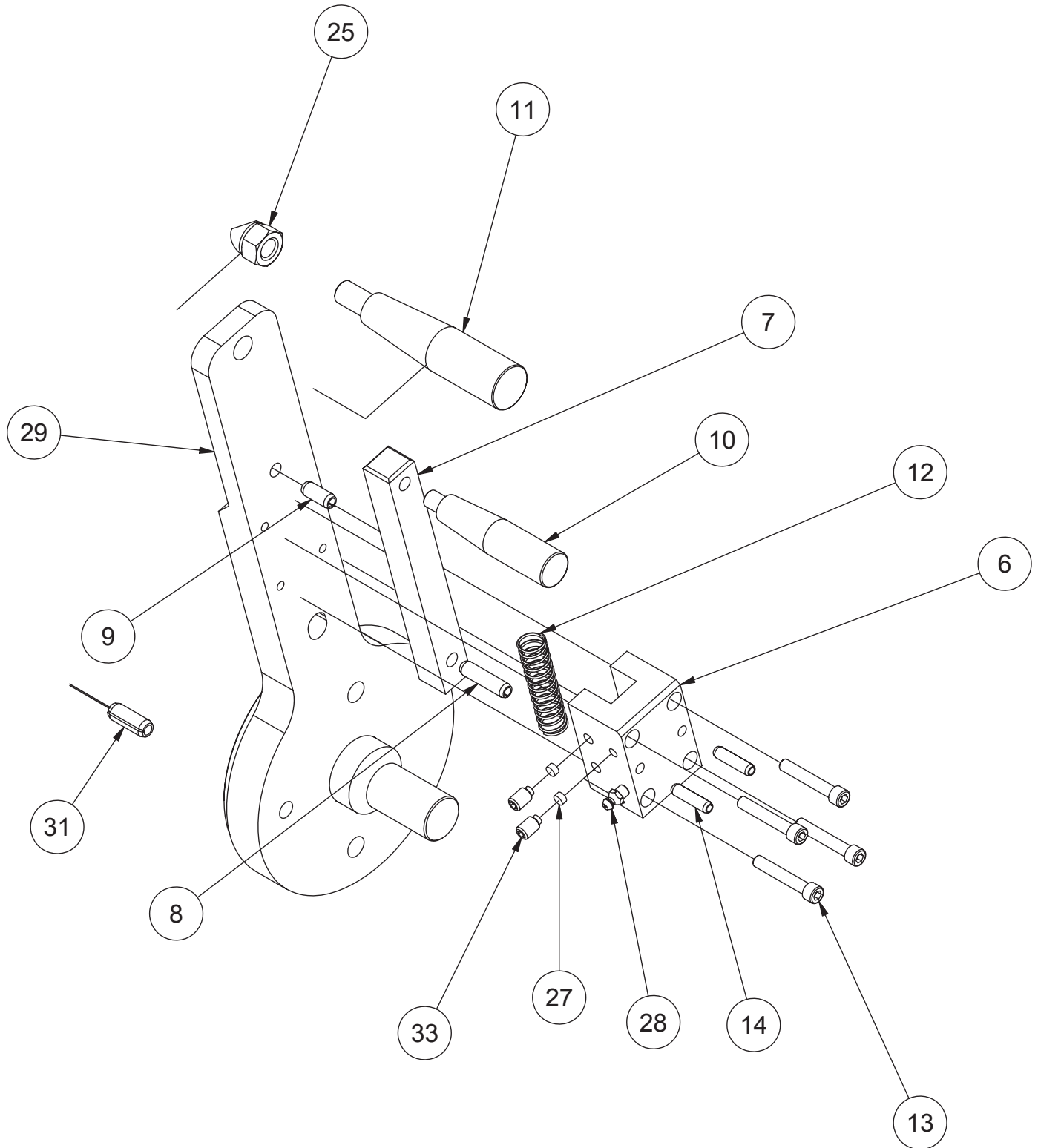

DETAIL A

514-7A BLOCK HOLD DOWN FIXTURE ASSEMBLY - HONE			
ITEM	QTY	PART NUMBER	DESCRIPTION
1	2	514-7-13	BLOCK, FLANGE, BLOCK HOLDDOWN FIXTURE
2	2	514-3-72A	PIN, SPRING RETAINER, BLOCK HOLD DOWN FIXTURE
3	1	514-3-34A	SPRING, EXTENSION - BLOCK HOLD DOWN FIXTURE
4	2	MF-165	1/2-13UNC HEX NUT
5	4	MF-39	Hexagon Socket Head Cap Screw
6	1	514-3-56A	INDEX PIN SUPPORT - BLOCK HOLD DOWN FIXTURE HONE
7	1	514-7-9B	INDEX PIN - BLOCK HOLD DOWN FIXTURE - HONE
8	1	MF-227A	Pin - Slotted Spring
9	1	MF-227B	Pin - Slotted Spring
10	1	514-3-58A	HANDLE, INDEX - BLOCK HOLD DOWN FIXTURE - HONE
11	1	514-3-59B	HANDLE, PIVOT ARM - BLOCK HOLD DOWN FIXTURE & V6/V8 AIR FIXTURE
12	1	514-3-70	SPRING, HANDLE RETURN
13	4	MF-17	Hexagon Socket Head Cap Screw
14	2	MF-226	Pin - Slotted Spring
15	1	MF-46A	Hexagon Socket Head Cap Screw
16	1	MF-166	5/8-11UNC HEX NUT
17	2	7223	CLAMP ASSEMBLY - MANUAL V6/V8 COMB. FIXTURE
18	4	514-7-21	Bellville Spring
19	2	514-7-22A	5/8 x 3/4" LG. SOCKET SHOULDER SCREW
20	2	514-7-10A	CLAMP ARM (MACHINING), BLOCK HOLD DOWN FIXTURE - HONE
21	2	514-7-1C	WASHER, HOLDDOWN - BLOCK HOLDDOWN FIXTURE - HONE
22	2	MF-32	S.H.C.S.3/8 - 16 UNC - 1 1/4
23	1	514-7-1E	MAIN FRAME REDESIGN (MACHINING)
24	2	514-7-15	SUPPORT, BLOCK - BLOCK HOLD DOWN FIXTURE
25	1	514-3-59C	1/2-13UNC ACORN NUT
26	1	514-7-14B	BAR, CLAMP - HOLD DOWN FIXTURE
27	2	514-3-56B	TERCITE PAD
28	1	MF-189	STRAIGHT GREASE FITTING
29	1	514-7-3D	MANUAL CRADLE HANDLE (MACHINING), HONE
30	1	514-13-14C	H70 - FIXTURE CRADLE MACHINING
31	1	MF-229B	3/8" x 1" LG. ROLL PIN
32	2	650-4-49	M14x2 x 25
33	2	7212C	5/16-18UNC x .50" LG. SOCKET HALF DOG SET SCREW

514-7-14E 2" 50.8mm Small Diameter Main Line Bar



502-1-30H Clamp Arm Assembly Parts

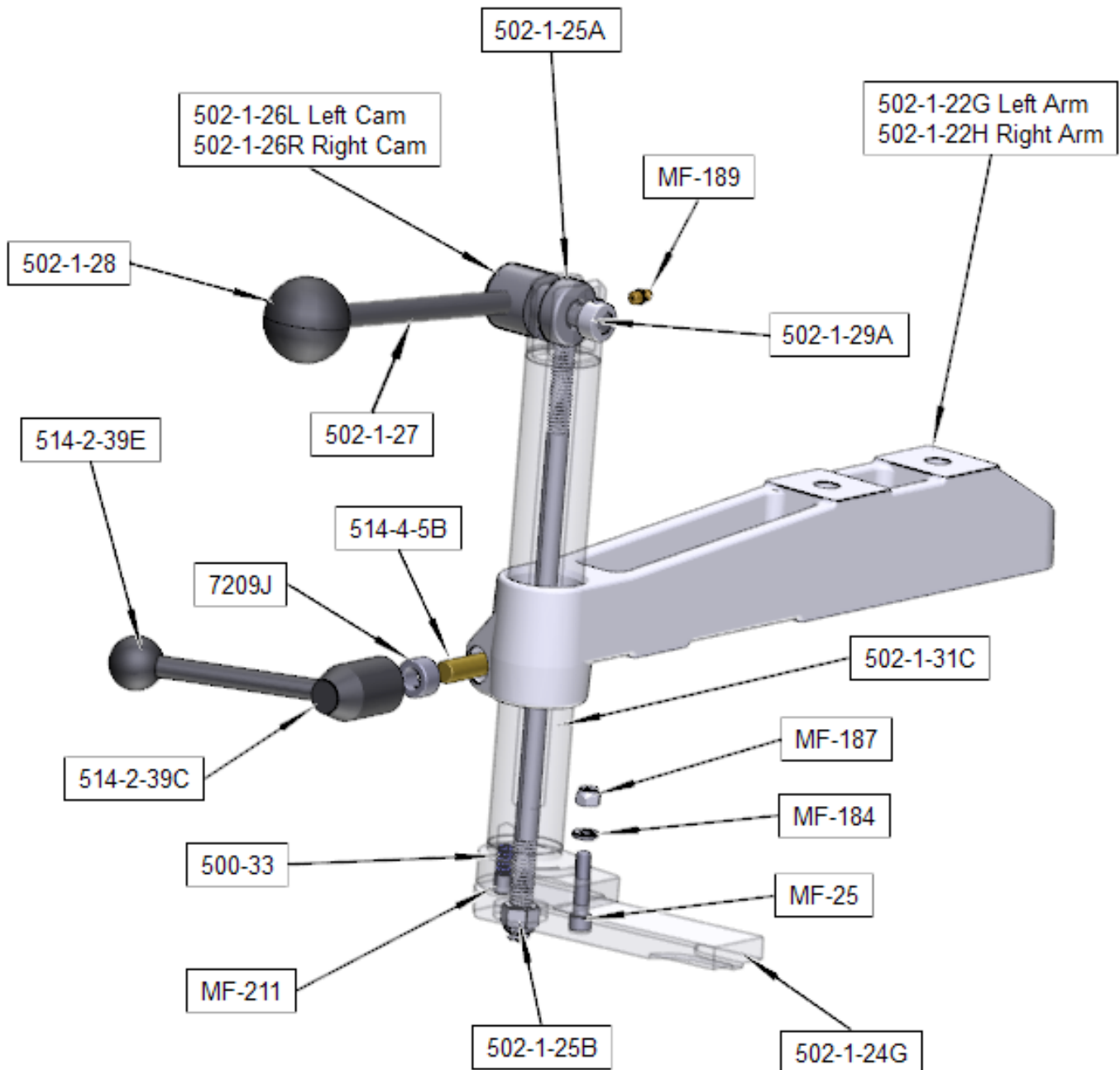

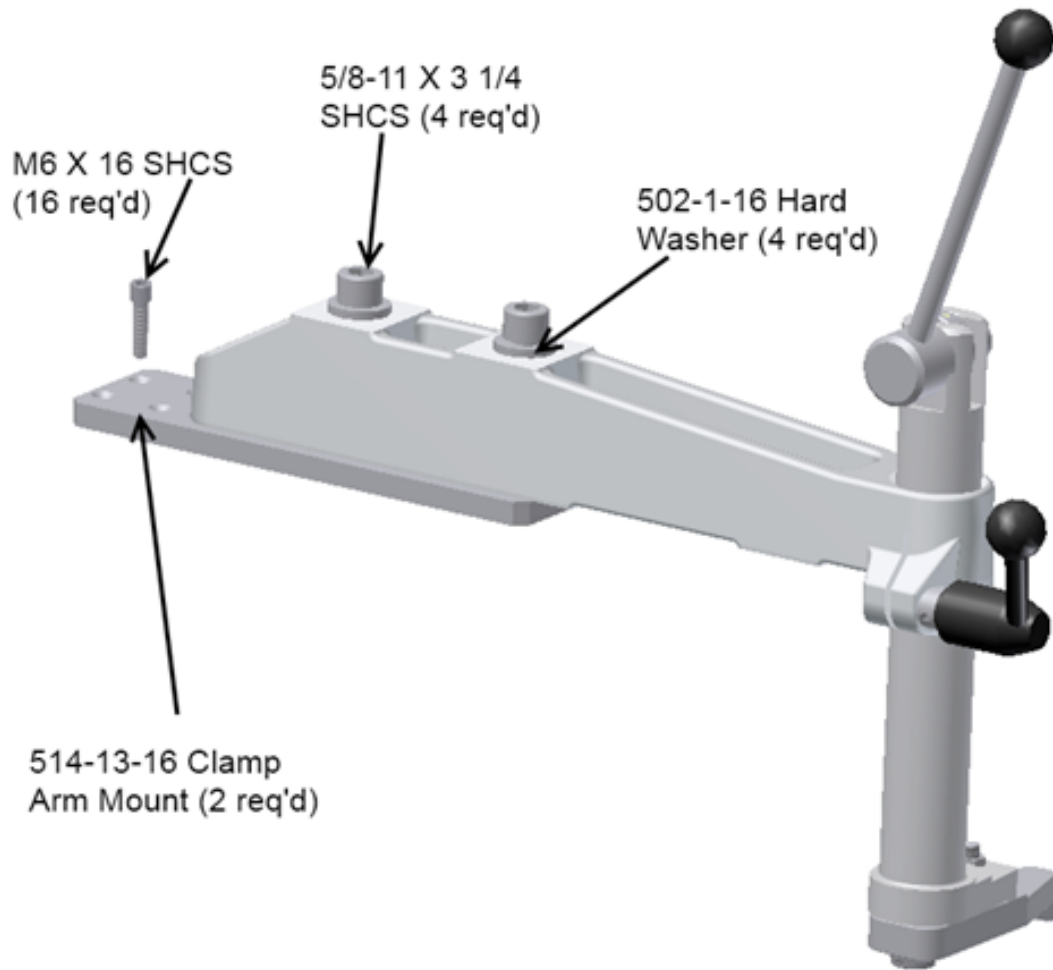

11115 2" (50mm) X 3" (75mm) Parallels
Sold only as complete assembly.

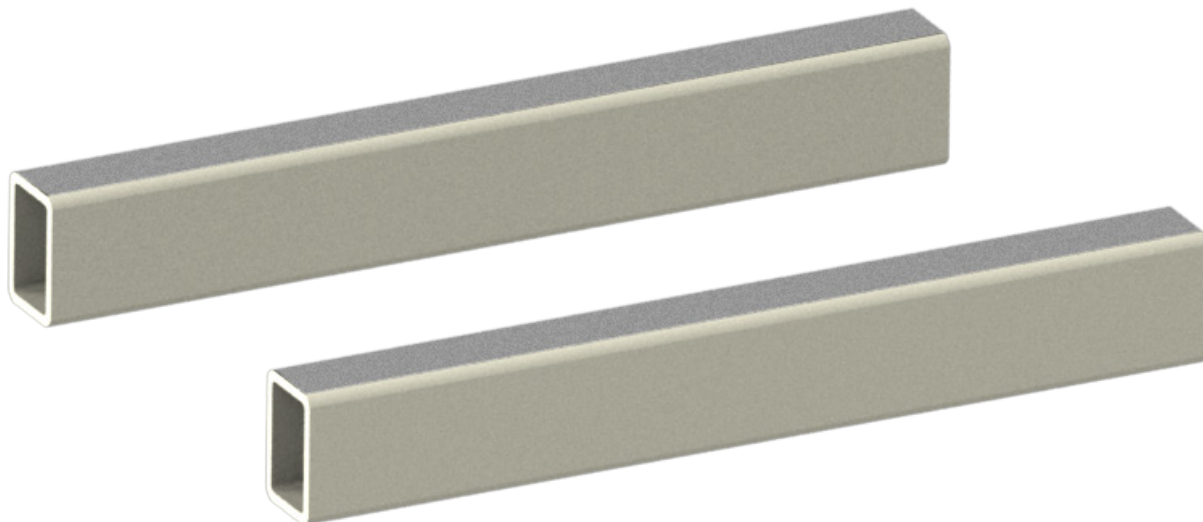

11112 Universal 8" (203mm) Heavy Duty T-Slot Parallels Parts

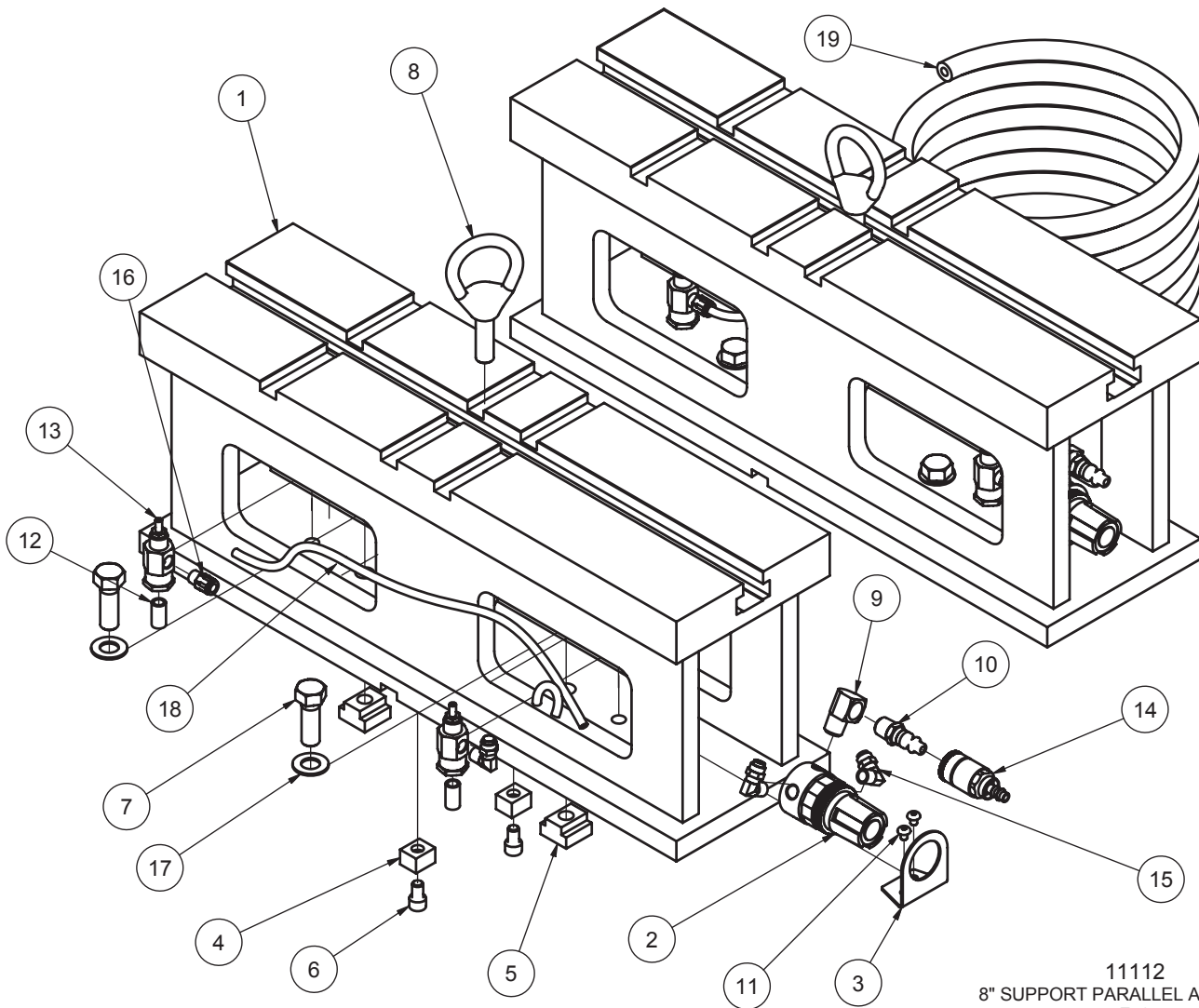

11112
8" SUPPORT PARALLEL ASSEMBLY
F70

11112 SUPPORT PARALLEL ASSEMBLY 8" - F70			
ITEM	QTY	PART NUMBER	DESCRIPTION
1	2	11112A	SUPPORT PARALLEL 8" (MACHINING) - F70
2	2	502-27-17	Regulator 0 - 60 PSI
3	2	502-27-17A	Regulator Bracket
4	4	650-3-9	Key
5	4	650-3-10	TN-5 T-Nut
6	4	MF-21A	5/16-18UNC x 1/2" LG. S.H.C.S.
7	4	MF-137A	1/2-13UNC x 1-1/2" LG. HEX BOLT
8	2	502-3-13	Lift Eye
9	2	502-11-17S	1/4 STREET ELL
10	2	502-11-16X	Quick Connect air Fitting Male
11	4	MF-87	10-24UNC x 1/4" LG. SOCKET BUTTONHEAD SCREW
12	4	502-11-17J	Nipple, Close 1/8" NPT
13	4	502-11-35A	Flo Control
14	1	502-11-16W	Quick connect air fitting female
15	6	502-11-16l	Elbow, Male 1/4 FPT x 1/8 PT
16	2	514-4-17W	FITTING 1/8NPT x 1/4" POLY STRAIGHT
17	4	MF-180	1/2" FLAT WASHER
18	3 FT.	502-11-15	1/4" OD BLACK POLYFLO
19	15 FT.	502-1-98	1/4" AIR HOSE

11114 Universal 16" (405mm) Heavy Duty T-Slot Parallels Parts

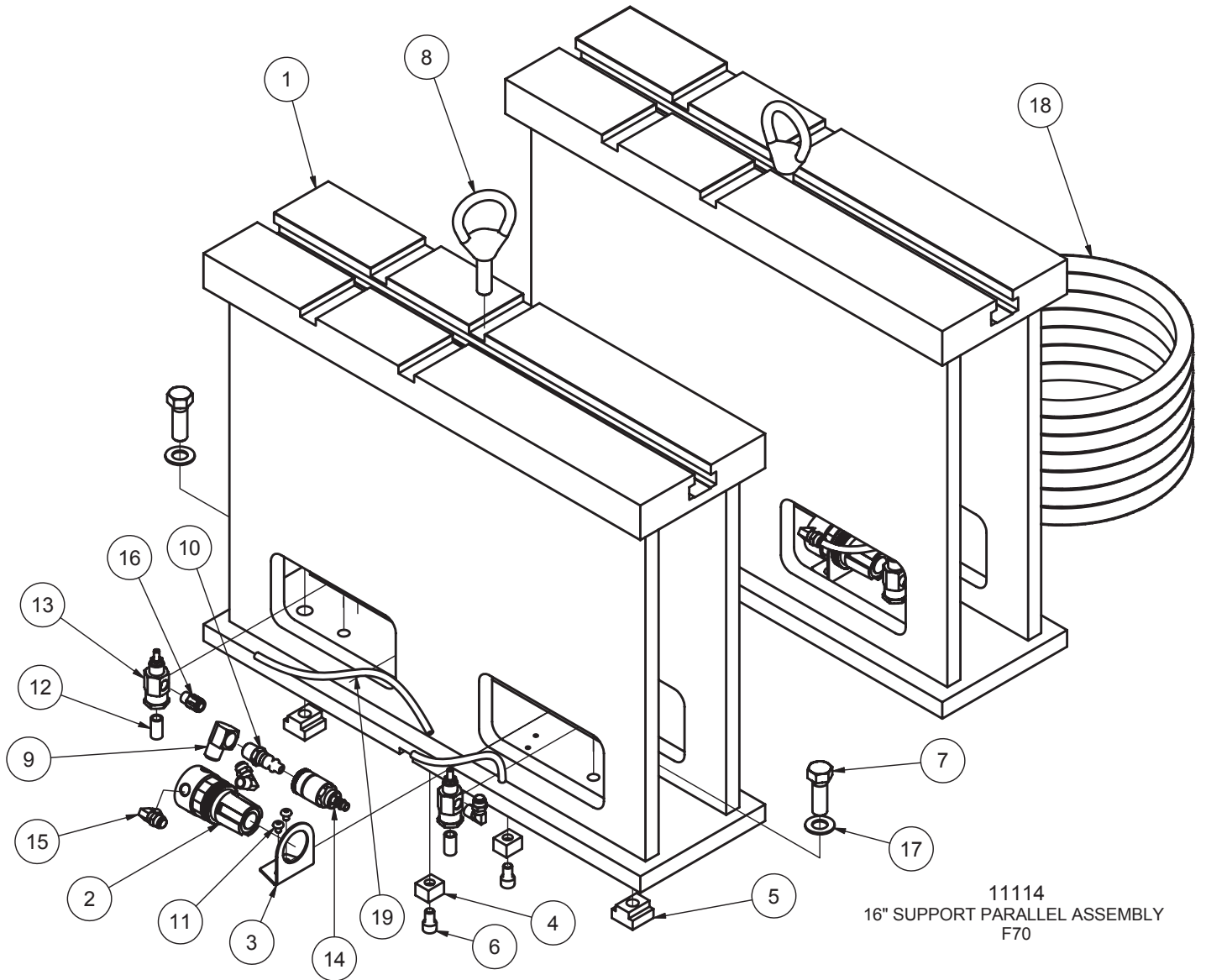

11114 SUPPORT PARALLEL ASSEMBLY 16" - F70			
ITEM	QTY	PART NUMBER	DESCRIPTION
1	2	11114A	SUPPORT PARALLEL 16" (MACHINING) - F70
2	2	502-27-17	Regulator 0 - 60 PSI
3	2	502-27-17A	Regulator Bracket
4	4	650-3-9	Key
5	4	650-3-10	TN-5 T-Nut
6	4	MF-21A	5/16-18UNC x 1/2" LG. S.H.C.S.
7	4	MF-137A	1/2-13UNC x 1-1/2" LG. HEX BOLT
8	2	502-3-13	Lift Eye
9	2	502-11-17S	1/4 STREET ELL
10	2	502-11-16X	Quick Connect air Fitting Male
11	4	MF-87	10-24UNC x 1/4" LG. SOCKET BUTTONHEAD SCREW
12	4	502-11-17J	Nipple, Close 1/8" NPT
13	4	502-11-35A	Flo Control
14	1	502-11-16W	Quick connect air fitting female
15	6	502-11-16I	Elbow, Male 1/4 FPT x 1/8 PT
16	2	514-4-17W	FITTING 1/8NPT x 1/4" POLY STRAIGHT
17	4	MF-180	1/2" FLAT WASHER
18	15 FT.	502-1-98	1/4" AIR HOSE
19	3 FT.	502-11-15	1/4" OD BLACK POLYFLO

Fixture for Honing Multiple Cylinder Liners (4 Liners)

514-11-5 Cylinder Liner Honing Fixture Parts

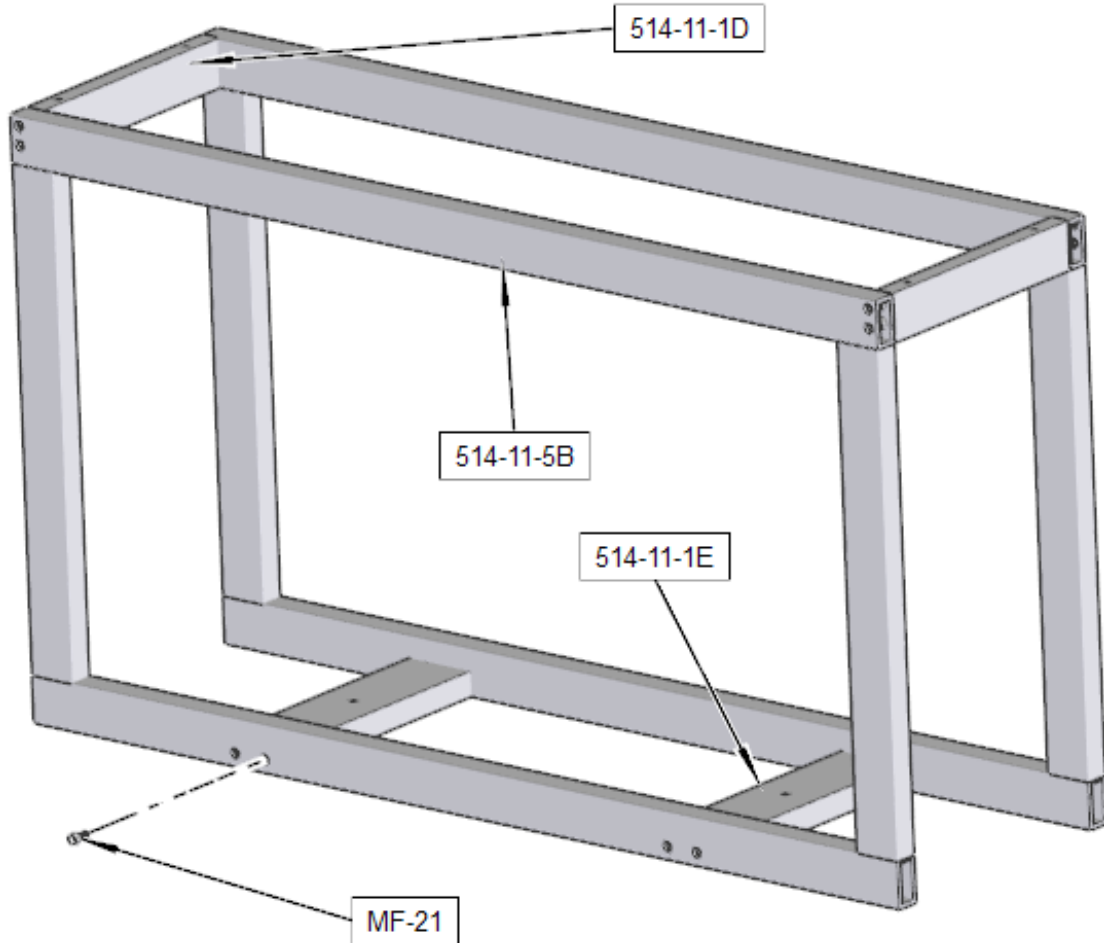

514-11-6 Fixture Plate Parts

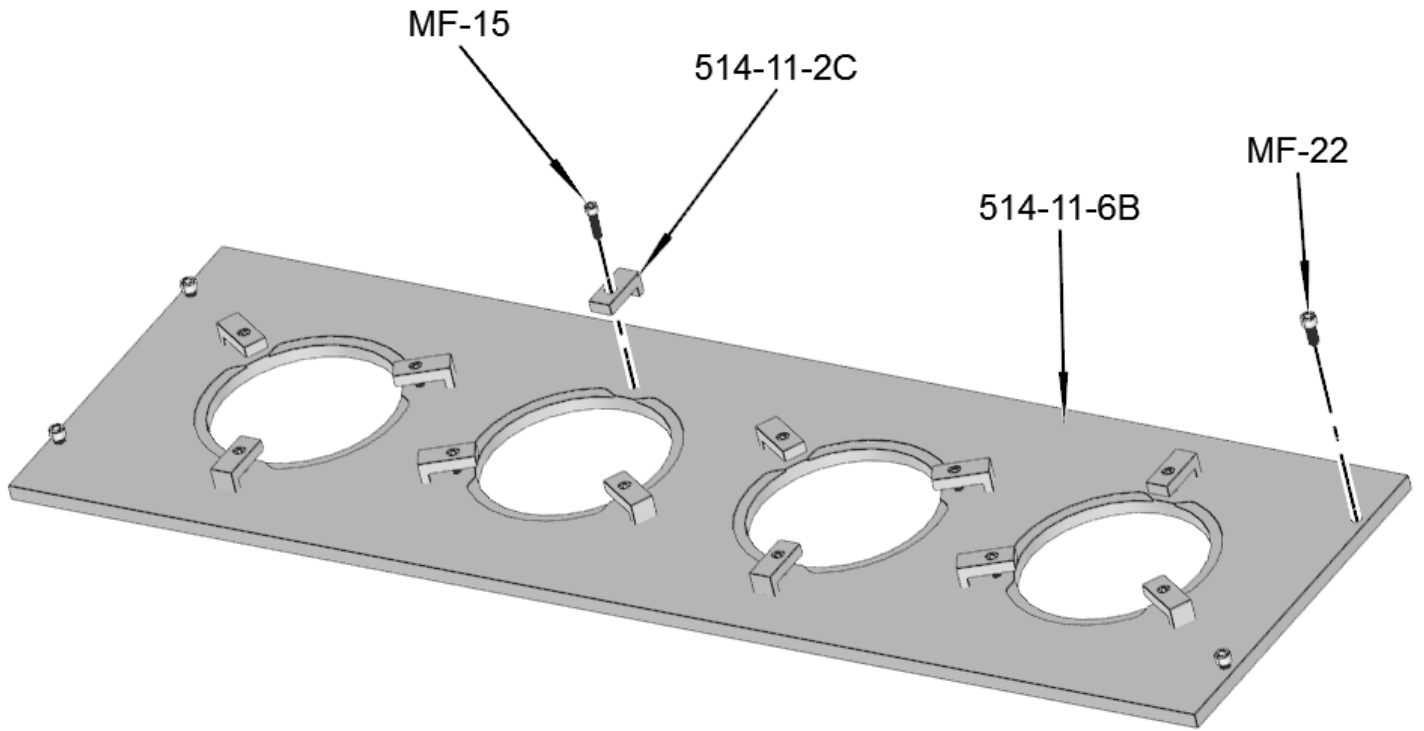

514-11-7 Fixture Plate Parts

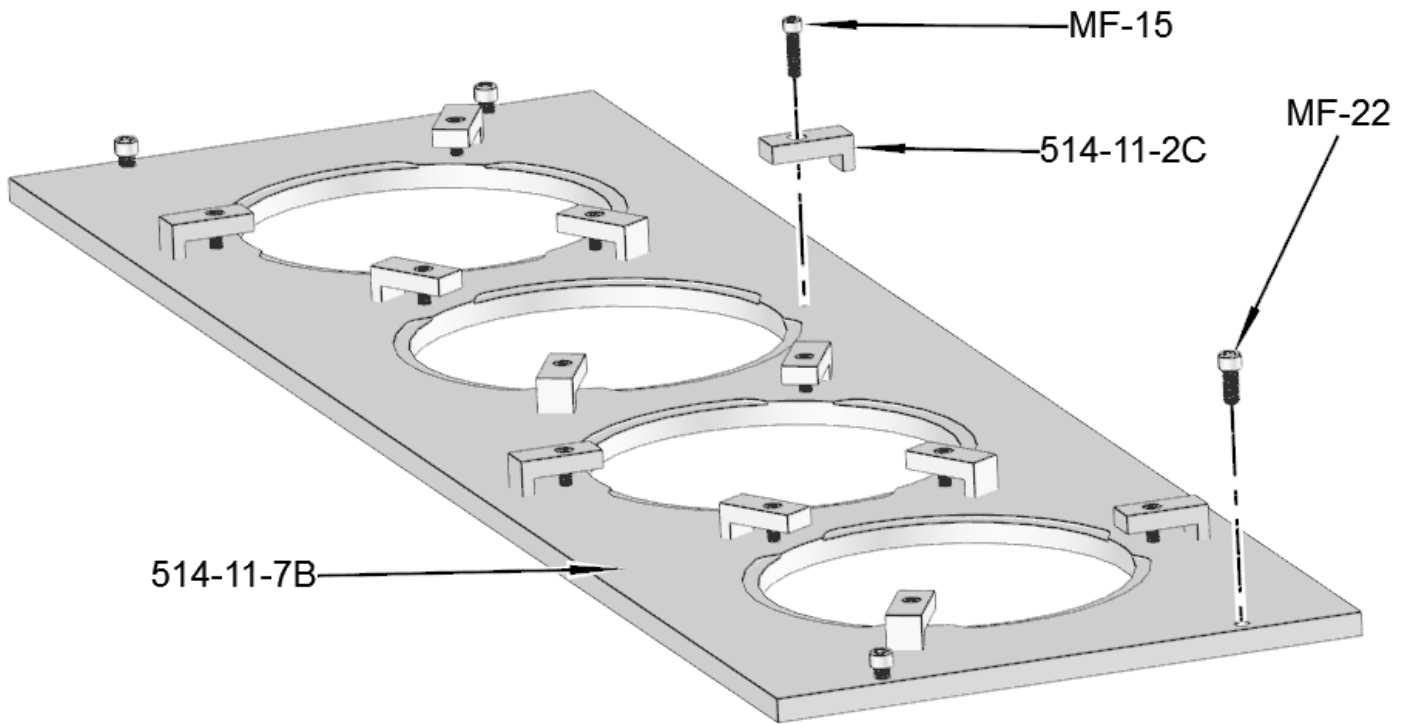

514-11-4 Fixture Plate Parts

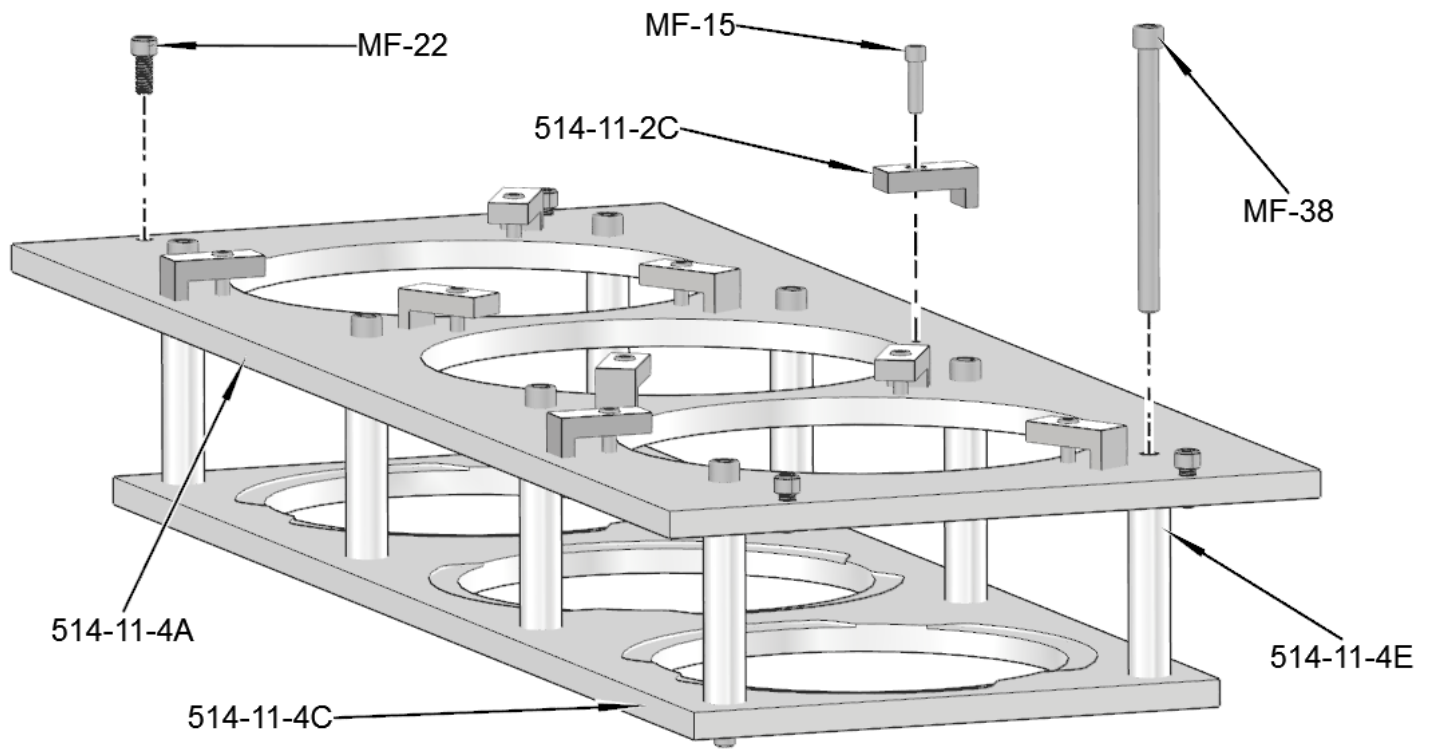

Optional Coolant and Filter Equipment

514-4-71C Synthetic Coolant

(for use with diamond stones) 5 gal (20 liter) (mix with water 20:1)



514-4-71D Coolant Refractor

Sold only as complete kit.



514-2-42C Dual Gradient 50-5 Micron Replacement Filter Cartridge
For standard filter system

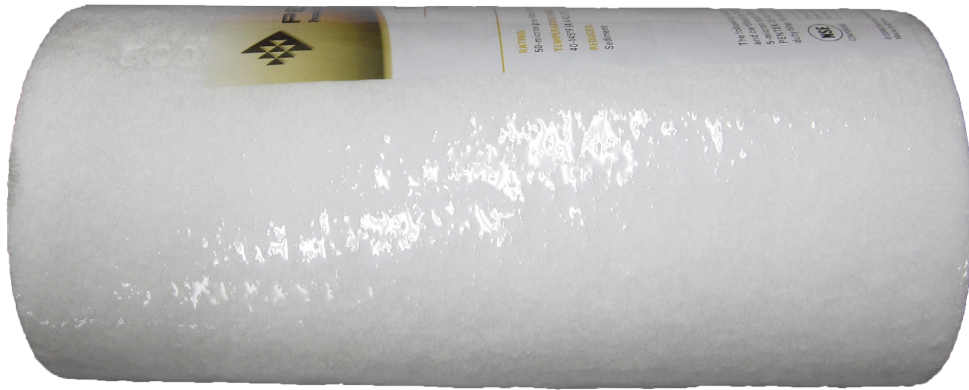

514-2-42A Cannister Magnetic Filter System
Sold only as complete kit.



Optional Rottler Precision Hone Heads, Sleeves and Stone Holders

514-9J Medium Rottler Precision 4 Stone Holder Hone Head Assembly Parts

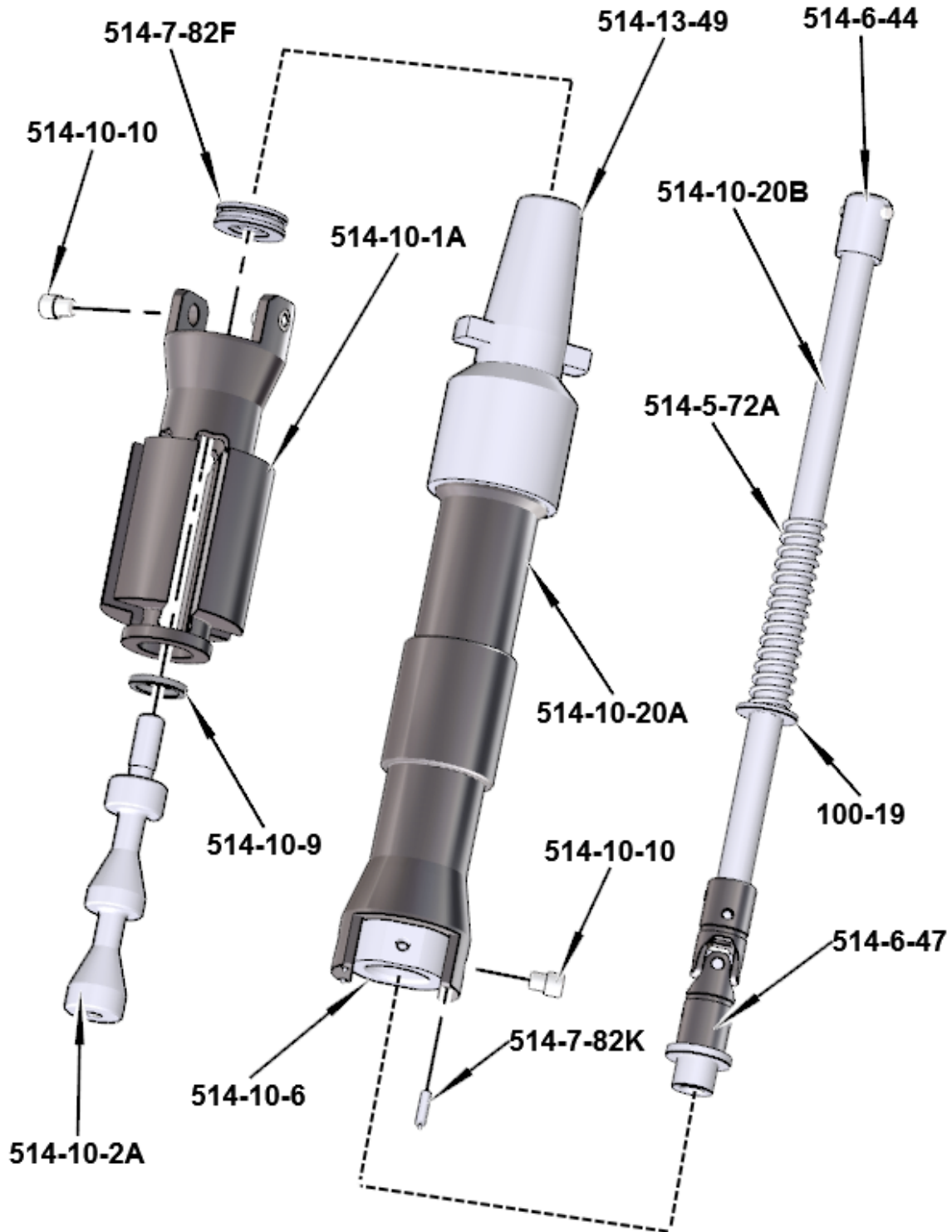

**514-10-13 Series Stone
Holder Parts**

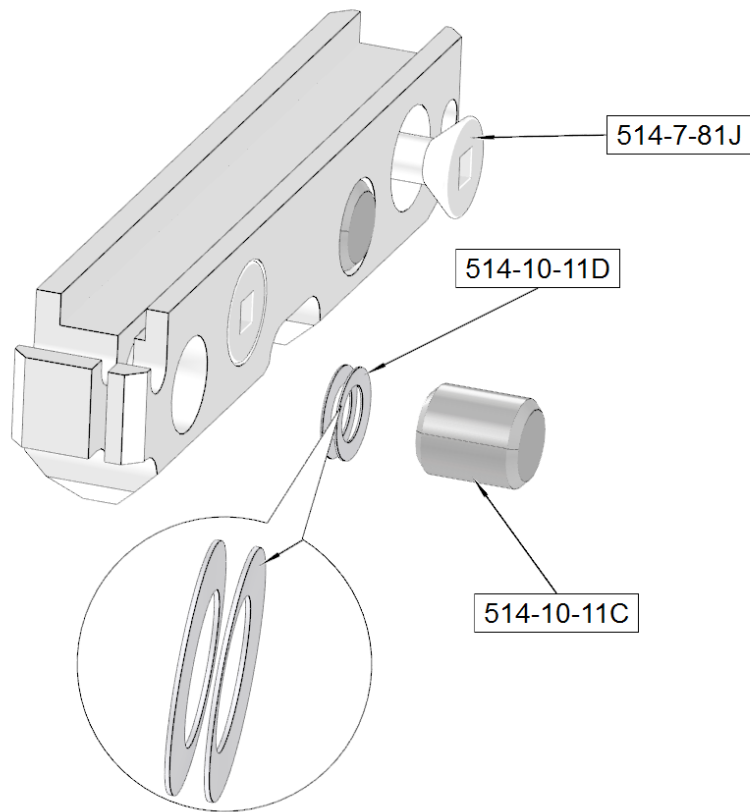

Medium Hone Head Stone Size Charts

Diameter (New Stones)

	0.312 Stones		0.200 Stones	
	Min	Max	Min	Max
514-10-13A	2.34	2.45	2.12	2.23
514-10-13F	2.44	2.55	2.22	2.33
514-10-13B	2.54	2.65	2.32	2.43
514-10-13G	2.64	2.75	2.42	2.53
514-10-13C	2.74	2.85	2.52	2.63
514-10-13H	2.84	2.95	2.62	2.73
514-10-13D	2.94	3.05	2.72	2.83

Diameter (New Stones) (Metric)

	7.925 Stones		5.08 Stones	
	Min	Max	Min	Max
514-10-13A	59.44	62.23	53.75	56.54
514-10-13F	61.98	64.77	56.29	59.08
514-10-13B	64.52	67.31	58.83	61.62
514-10-13G	67.06	69.85	61.37	64.16
514-10-13C	69.60	72.39	63.91	66.70
514-10-13H	72.14	74.93	66.45	69.24
514-10-13D	74.68	77.47	68.99	71.78

Diameter (New Brushes)

	0.550 Brushes		0.395 Brushes	
	Min	Max	Min	Max
514-10-13A	2.82	2.93	2.51	2.62
514-10-13F	2.92	3.03	2.61	2.72
514-10-13B	3.02	3.13	2.71	2.82
514-10-13G	3.12	3.23	2.81	2.92
514-10-13C	3.22	3.33	2.91	3.02
514-10-13H	3.32	3.43	3.01	3.12
514-10-13D	3.42	3.53	3.11	3.22

Diameter (New Brushes) (Metric)

	13.970 Brushes		10.033 Brushes	
	Min	Max	Min	Max
514-10-13A	71.53	74.32	63.65	66.45
514-10-13F	74.07	76.86	66.19	68.99
514-10-13B	76.61	79.40	68.73	71.53
514-10-13G	79.15	81.94	71.27	74.07
514-10-13C	81.69	84.48	73.81	76.61
514-10-13H	84.23	87.02	76.35	79.15
514-10-13D	86.77	89.56	78.89	81.69

514-9Q Large Rottler Precision Heavy Duty 6 Stone Holder Hone Head Assembly Parts

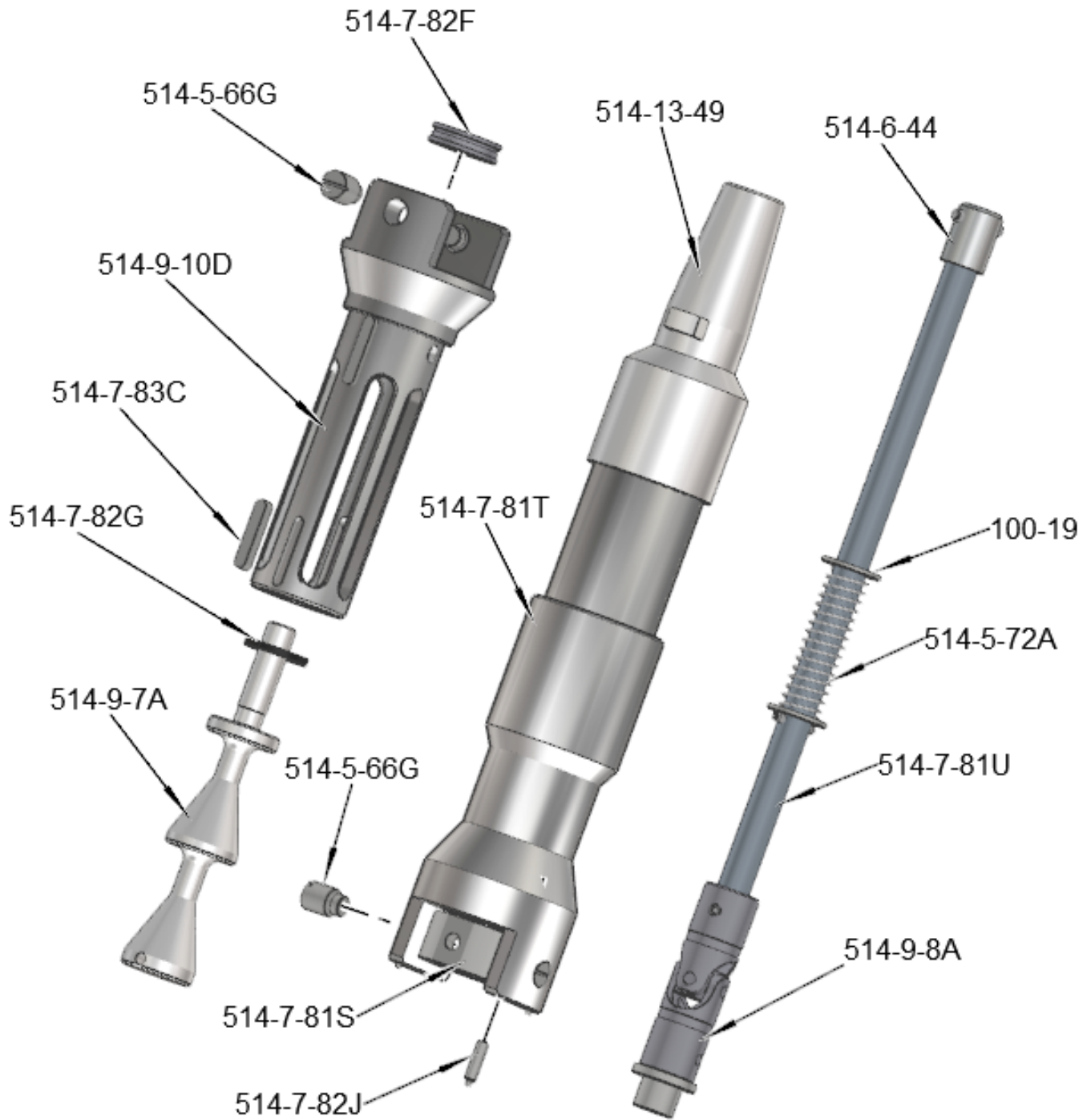

514-9S Large Rottler Precision Heavy Duty 6 Stone Holder Hone Head Assembly Parts

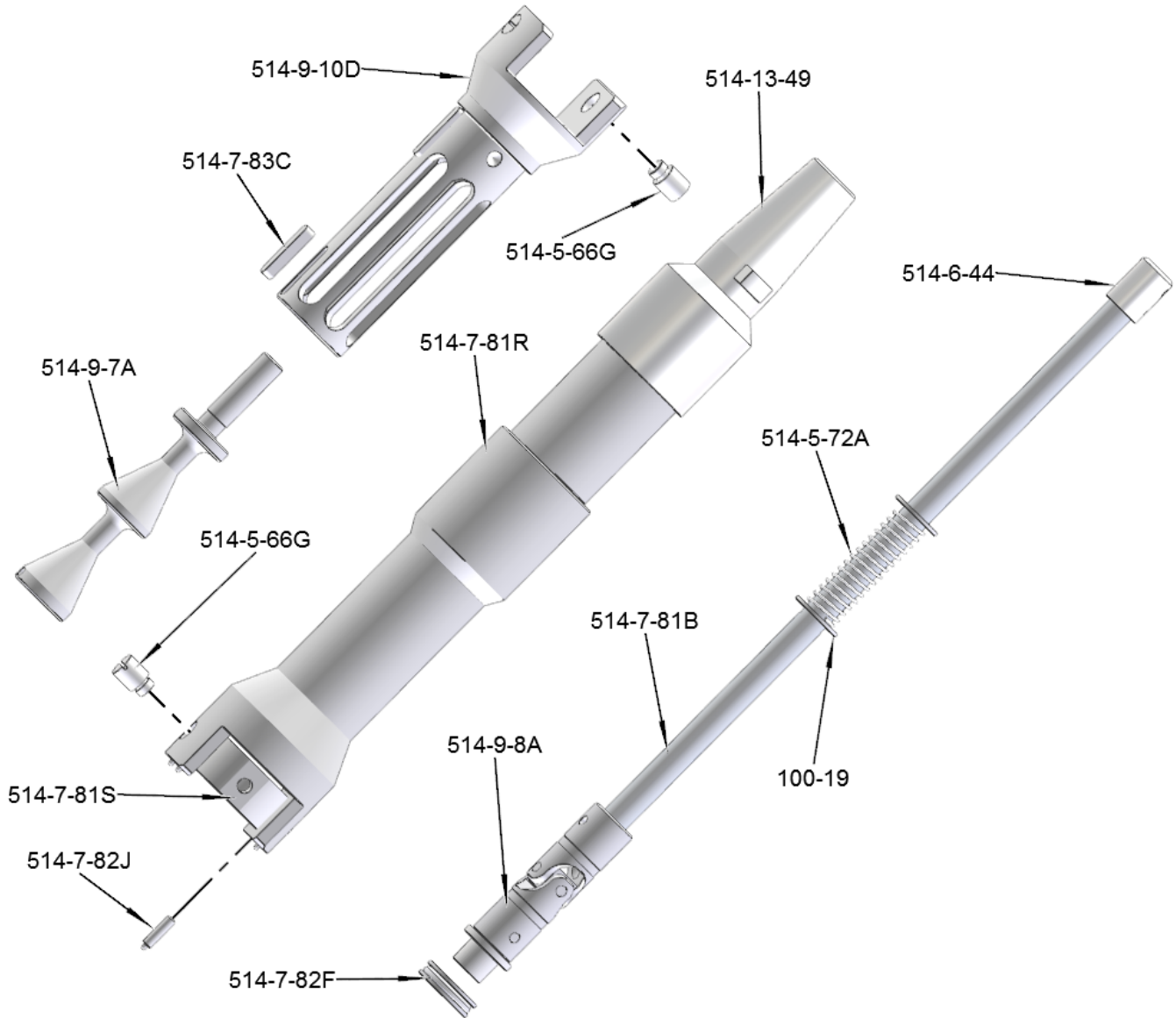

514-9-4E Sleeve Assembly Parts

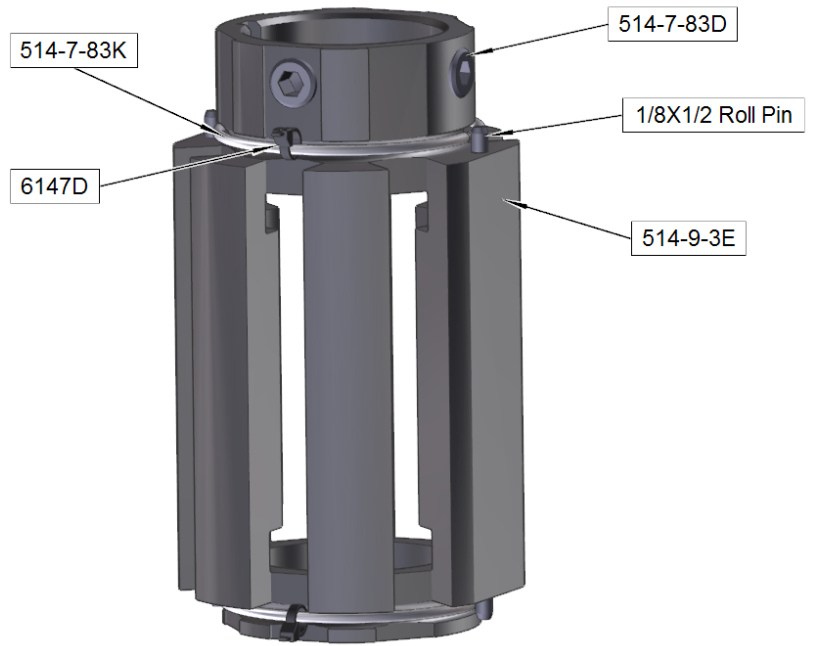

514-9-4F Sleeve Assembly Parts

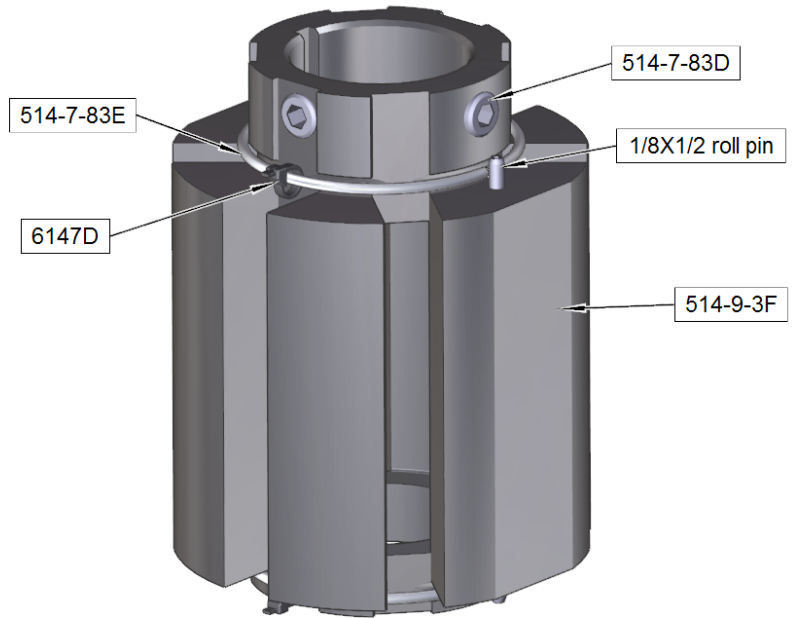

514-9-4G Sleeve Assembly Parts

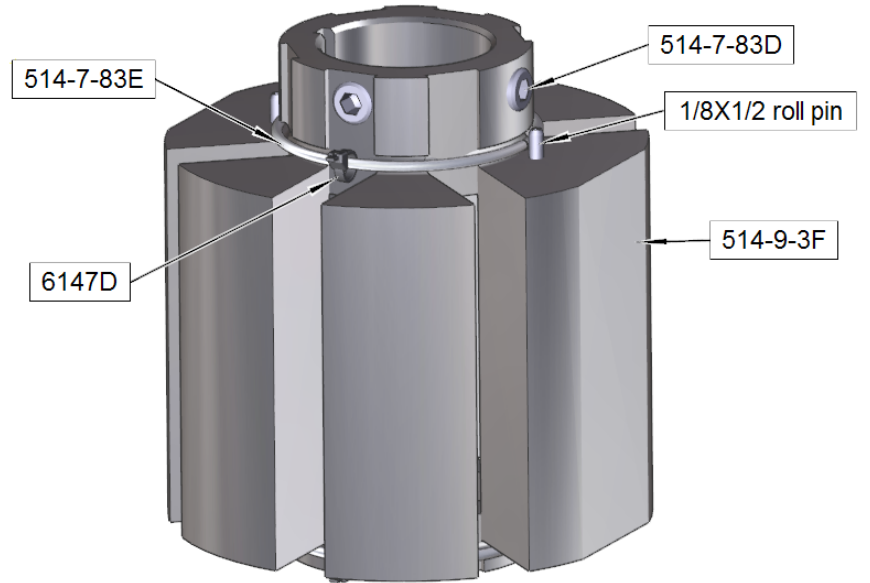

514-9-31 Series Stone Holder Parts

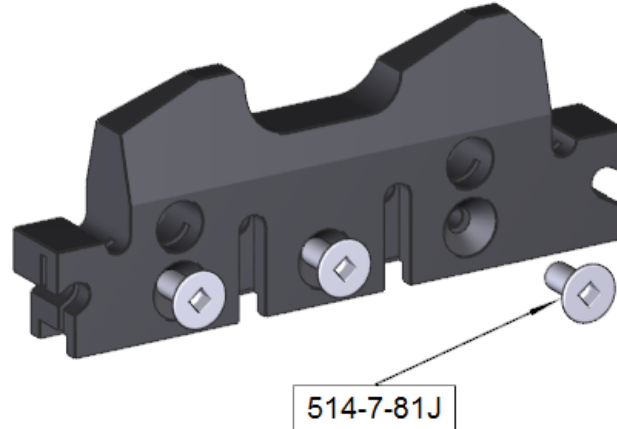

Six Stone Hone Head Stone Size Chart

	Diameter (New Stones)			
	0.312 Stones		0.200 Stones	
	Min	Max	Min	Max
514-9-31J	2.99	3.45	2.77	3.23
514-9-31A	3.17	3.63	2.94	3.41
514-9-31B	3.42	3.88	3.19	3.66
514-9-31C	3.67	4.13	3.44	3.91
514-9-31D	3.92	4.38	3.69	4.16
514-9-31E	4.17	4.63	3.94	4.41
514-9-31F	4.42	4.88	4.19	4.66
514-9-31G	4.67	5.13	4.44	4.91
514-9-31H	4.92	5.38	4.69	5.16
514-9-31K	5.17	5.63	4.94	5.41
514-9-31L	5.42	5.88	5.19	5.66
514-9-31M	5.67	6.13	5.44	5.91
514-9-31N	5.92	6.38	5.69	6.16
514-9-31P	6.17	6.63	5.94	6.41
514-9-31Q	6.42	6.88	6.19	6.66
514-9-31R	6.67	7.13	6.44	6.91
514-9-31S	6.92	7.38	6.69	7.16



Diameter (New Stones) (Metric)				
	7.9248 Stones		5.08 Stones	
	Min	Max	Min	Max
514-9-31J	75.92	87.73	70.23	82.04
514-9-31A	80.39	92.20	74.70	86.51
514-9-31B	86.74	98.55	81.05	92.86
514-9-31C	93.09	104.90	87.40	99.21
514-9-31D	99.44	111.25	93.75	105.56
514-9-31E	105.79	117.60	100.10	111.91
514-9-31F	112.14	123.95	106.45	118.26
514-9-31G	118.49	130.30	112.80	124.61
514-9-31H	124.84	136.65	119.15	130.96
514-9-31K	131.19	143.00	125.50	137.31
514-9-31L	137.54	149.35	131.85	143.66
514-9-31M	143.89	155.70	138.20	150.01
514-9-31N	150.24	162.05	144.55	156.36
514-9-31P	156.59	168.40	150.90	162.71
514-9-31Q	162.94	174.75	157.25	169.06
514-9-31R	169.29	181.10	163.60	175.41
514-9-31S	175.64	187.45	169.95	181.76

Diameter (New Brushes)				
	0.550 Brushes		0.395 Brushes	
	Min	Max	Min	Max
514-9-31J	3.47	3.93	3.16	3.62
514-9-31A	3.64	4.11	3.33	3.80
514-9-31B	3.89	4.36	3.58	4.05
514-9-31C	4.14	4.61	3.83	4.30
514-9-31D	4.39	4.86	4.08	4.55
514-9-31E	4.64	5.11	4.33	4.80
514-9-31F	4.89	5.36	4.58	5.05
514-9-31G	5.14	5.61	4.83	5.30
514-9-31H	5.39	5.86	5.08	5.55
514-9-31K	5.64	6.11	5.33	5.80
514-9-31L	5.89	6.36	5.58	6.05
514-9-31M	6.14	6.61	5.83	6.30
514-9-31N	6.39	6.86	6.08	6.55
514-9-31P	6.64	7.11	6.33	6.80
514-9-31Q	6.89	7.36	6.58	7.05
514-9-31R	7.14	7.61	6.83	7.30
514-9-31S	7.39	7.86	7.08	7.55



Diameter (New Brushes) (Metric)				
	13.97 Brushes		10.033 Brushes	
	Min	Max	Min	Max
514-9-31J	88.01	99.82	80.14	91.95
514-9-31A	92.48	104.29	84.61	96.42
514-9-31B	98.83	110.64	90.96	102.77
514-9-31C	105.18	116.99	97.31	109.12
514-9-31D	111.53	123.34	103.66	115.47
514-9-31E	117.88	129.69	110.01	121.82
514-9-31F	124.23	136.04	116.36	128.17
514-9-31G	130.58	142.39	122.71	134.52
514-9-31H	136.93	148.74	129.06	140.87
514-9-31K	143.28	155.09	135.41	147.22
514-9-31L	149.63	161.44	141.76	153.57
514-9-31M	155.98	167.79	148.11	159.92
514-9-31N	162.33	174.14	154.46	166.27
514-9-31P	168.68	180.49	160.81	172.62
514-9-31Q	175.03	186.84	167.16	178.97
514-9-31R	181.38	193.19	173.51	185.32
514-9-31S	187.73	199.54	179.86	191.67

Diamond Abrasives for Rottler Precision 6 Stone Holder Hone Heads

NOTE: Ra - Roughness Average. Value before Ra is in micro inches. Value in brackets um is micro meters. Long designates length of stone. Height designated thickness of stone.

Diamond Stones, .312 (7.90MM), Set of 6

514-9-32F Diamond Stones, 80 grit
3" (76mm) long set of 6, 90 Ra, (2.25um)

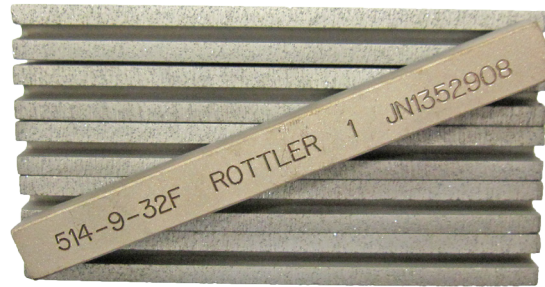

514-9-32R Diamond Stones 80 grit
3.5" (89mm) long set of 6, 90 Ra, (2.25um)



514-9-32W Diamond Stones, 140/170 grit
3" (76mm) long set of 6, 50-75 Ra, (1.25 - 1.875um)

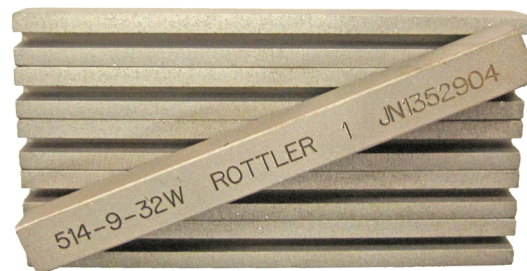

514-9-32K Diamond Stones, 170/200 grit
3" (76mm) long set of 6, 45-60 Ra, (1.125 - 1.5um)

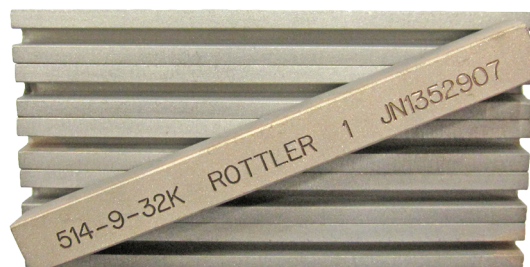

514-9-32J Diamond Stones, 270/325 grit
3" (76mm) long set of 6, 35-45 Ra, (.875 - 1.125um)

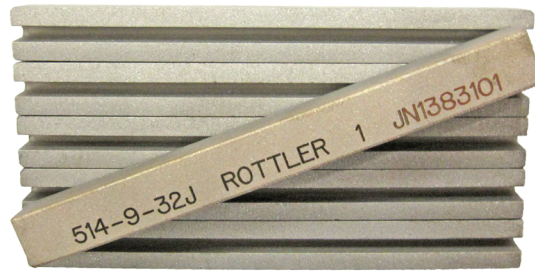

514-9-32E Diamond Stones, 325/400 grit
3" (76mm) long set of 6, 24-30 Ra, (.6 - .75um)



514-9-33K Diamond Stones, 325/400 grit
4" (102mm) long set of 6, 24-30 Ra, (.6 - .75um)

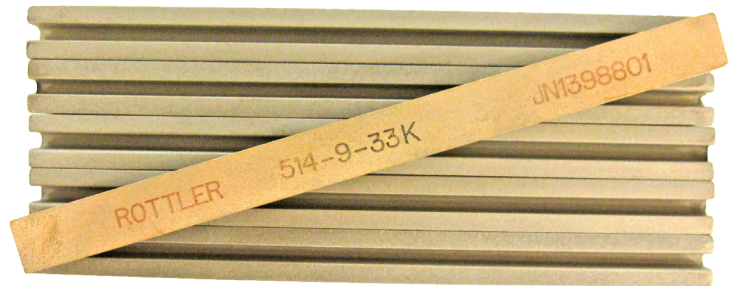

514-9-32C Diamond Stones, 500 grit
3" (76mm) long set of 6, 18-22 Ra, (.45 - .55um)

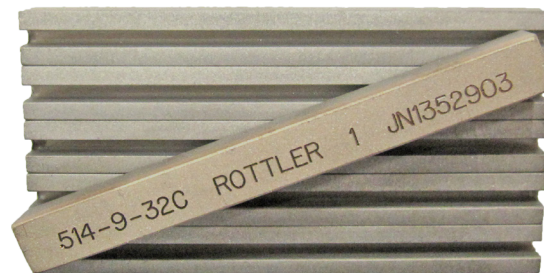

514-9-32L Diamond Stones, 550 grit
3" (76mm) long set of 6, 15-19 Ra, (.375 - .475)



514-9-32G Diamond Stones, 600 grit
3" (76mm) long set of 6, 8-12 Ra, (.2 - .3um)



514-9-33 Diamond Stones, 800 grit
3" (76mm) long set of 6



514-9-33C Diamond Stones, 800 grit
4" (102mm) long set of 6

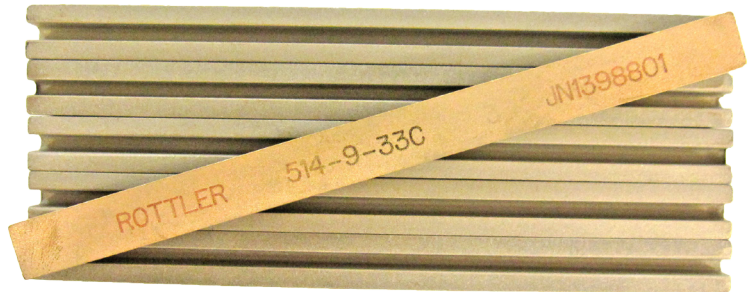

514-9-33J Diamond Stones, 1200 grit
3" (76mm) long set of 6



Diamond Stones, .200 (5.08MM), Set of 6**514-9-33B Diamond Stones, 270/325 grit**

3.5" (89mm) long set of 6, 35-45 Ra,

**514-9-32D Diamond Stones, 325/400 grit**

3" (76mm) long set of 6, 18-22 Ra, 2.795 bore

**514-9-33A Diamond Stones, 800 grit**

3.5" (89mm) long set of 6

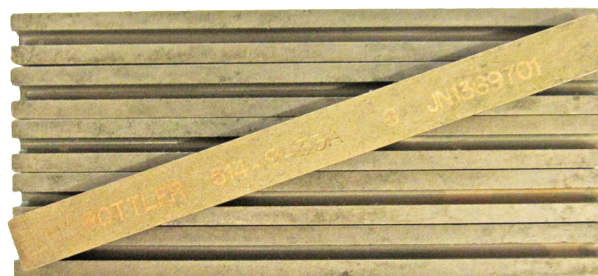

CBN Stones for Super Finishing with Rottler Precision 4 and 6 Stone Holder Hone Heads

514-9-35C CBN Stones, 320 grit
3" (76mm) long set of 4, for super finishing



514-9-35D CBN Stones, 400 grit
3" (76mm) long set of 4, for super finishing



514-9-35B CBN Stones, 600 grit
3" (76mm) long set of 4, for super finishing

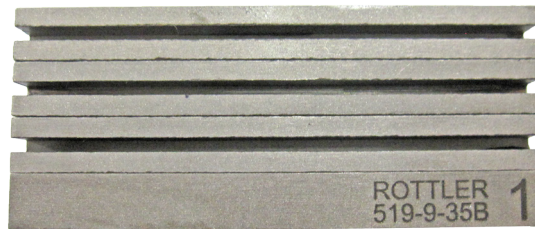

Brushes for Plateau Finishing with Rottler Precision 4 and 6 Stone Holder Hone Heads

514-9-14H Brushes, for Plateau Finishing
.550" (14mm) height, 3 1/2" (89mm) long, requires one or two size smaller stone holder compared to .312" (7.90mm) height diamond stone. Set of 4



514-9-14Y Brushes, for Plateau Finishing
.395" (10mm) height, 3 1/2" (89mm) long, requires same or one size smaller stone holder compared to .312" (7.90mm) height diamond stone. Set of 4



514-9P Large Rottler Precision Heavy Duty 4 Stone Holder Hone Head Assembly Parts

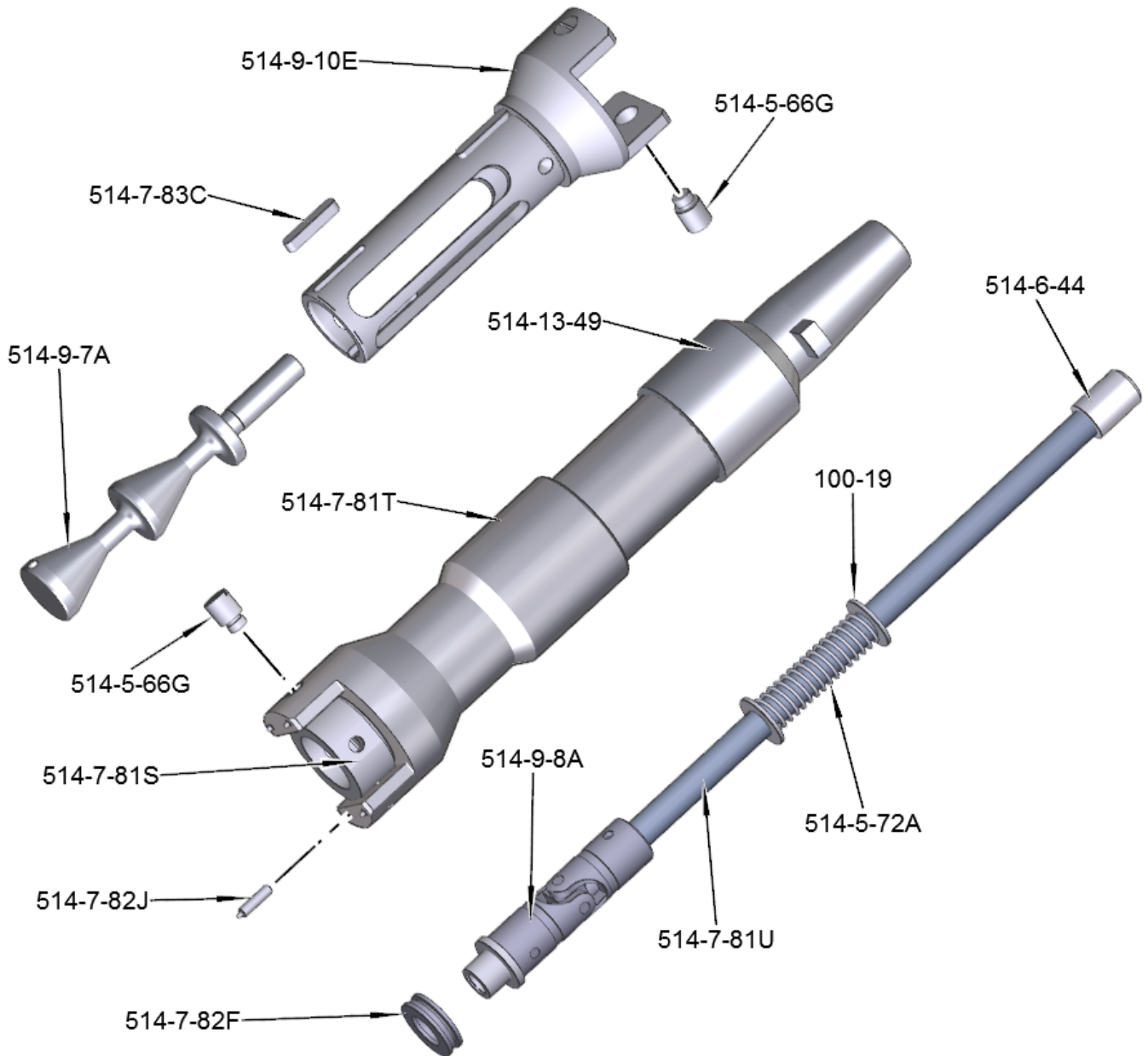

514-9R Large Rottler Precision Heavy Duty 4 Stone Holder Hone Head Assembly Parts

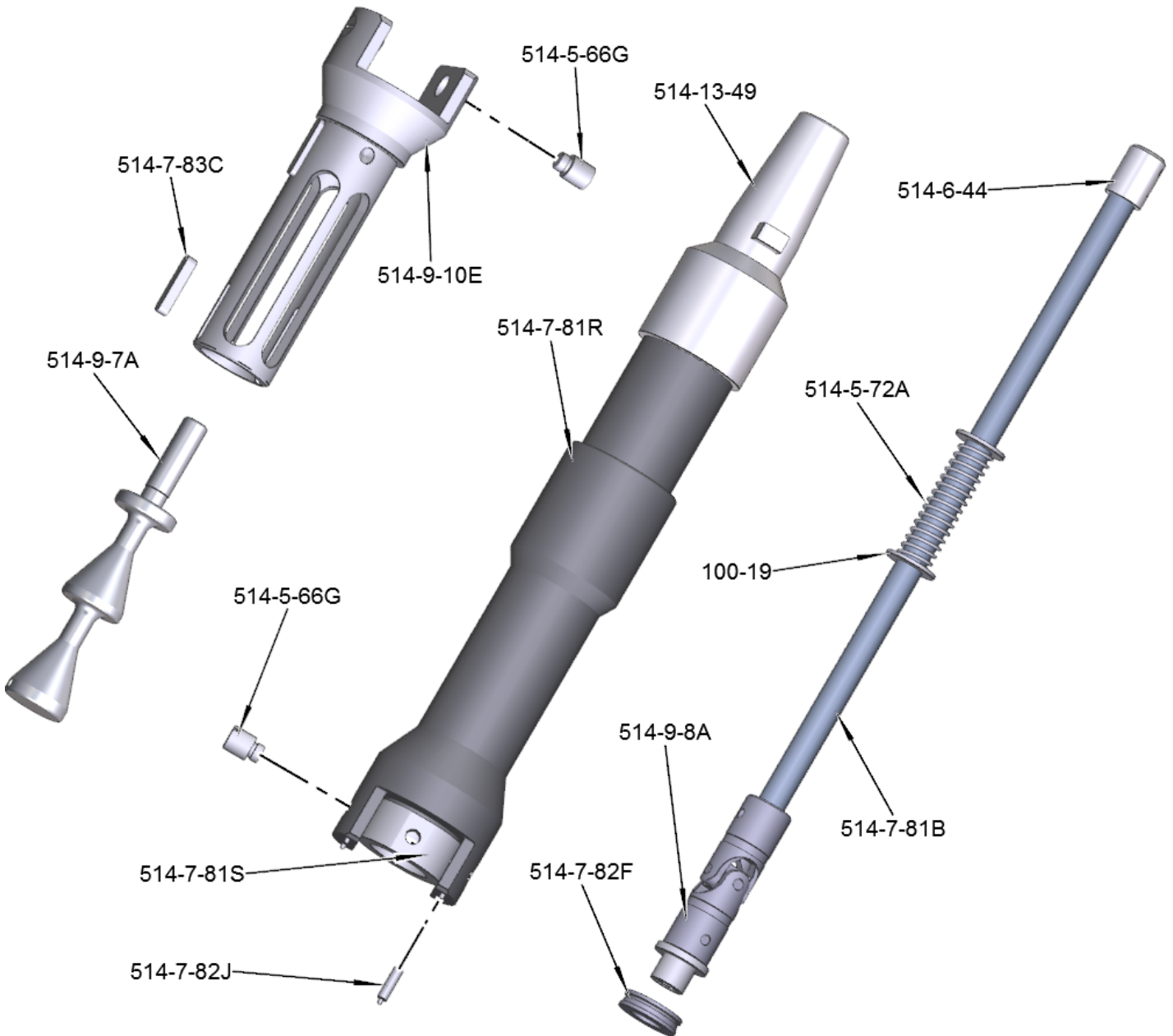

514-9-4A Sleeve Assembly Parts

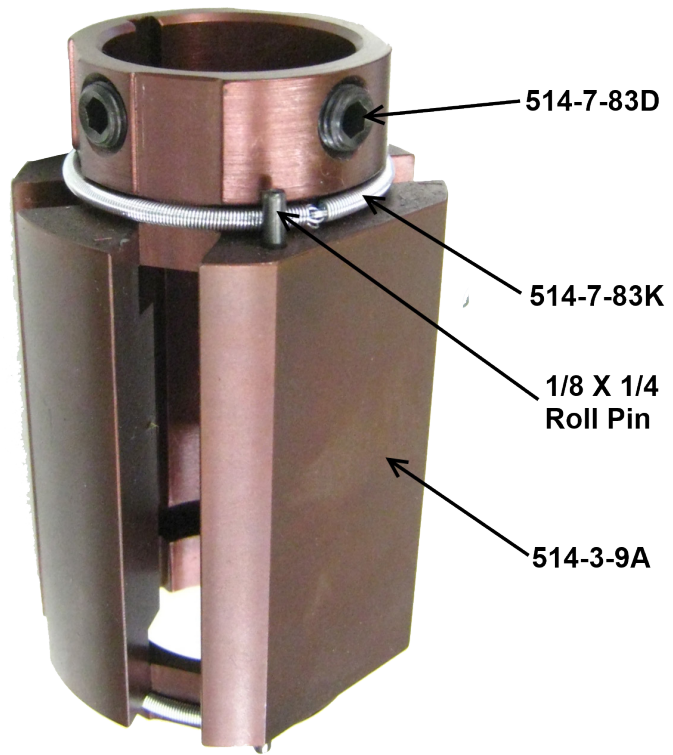

514-9B Sleeve Assembly Parts

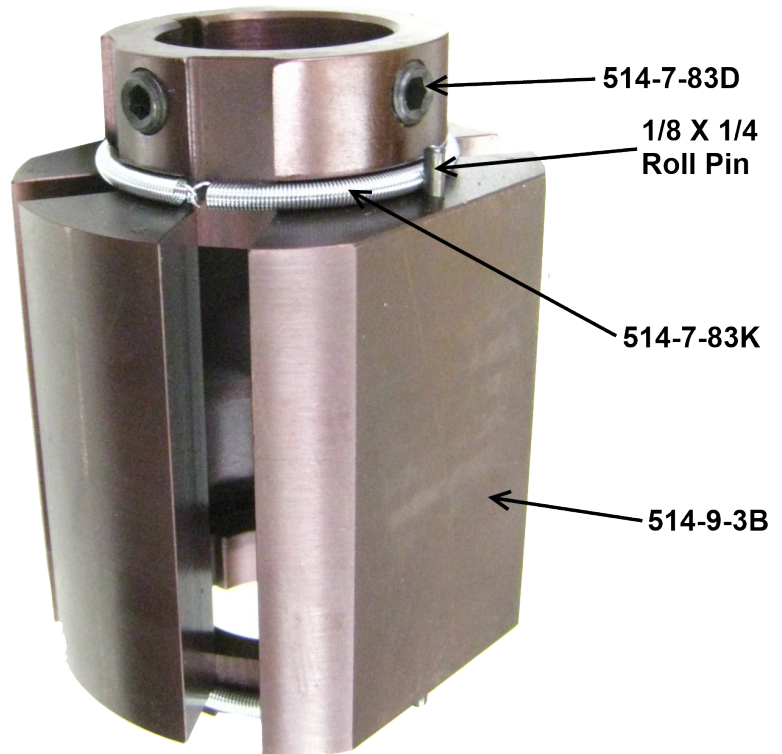

514-9-4G Sleeve Assembly Parts

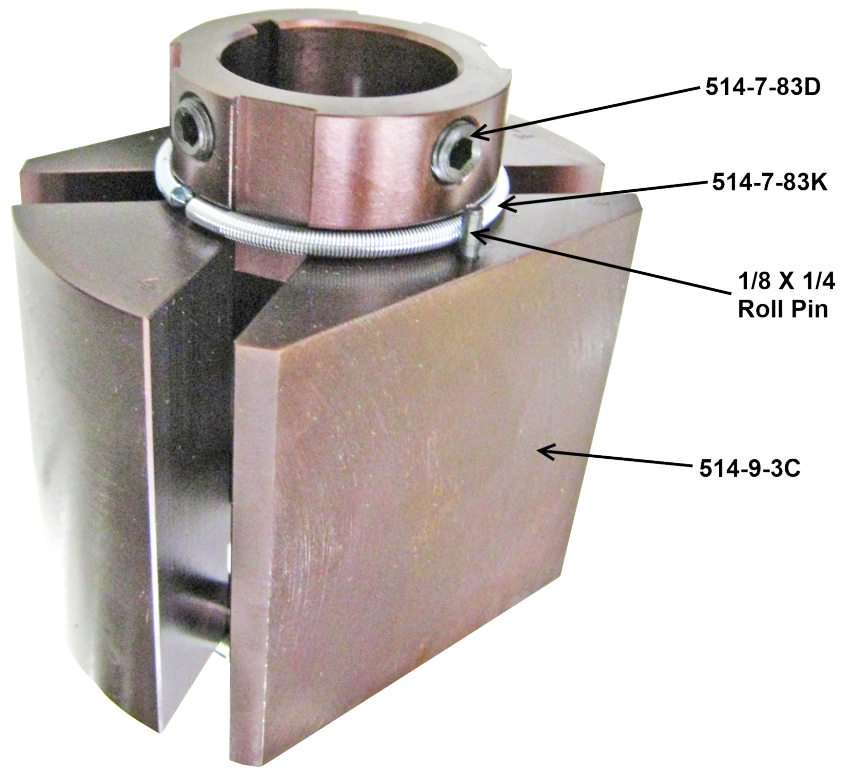

514-9-6 Series Stone Holder Parts

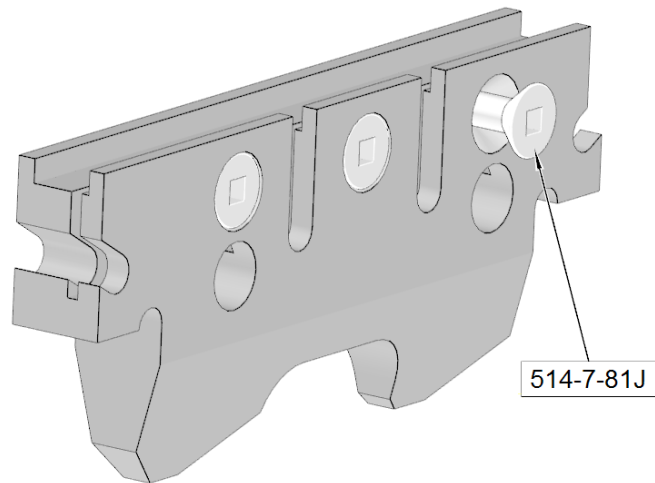

514-9-6 Series Stone Holder Size Chart

Stone Set #	Size Range	Sleeve Used In
514-9-6J	2.990 - 3.44" (75.95 - 87.38mm)	514-9-4A
514-9-6A	3.165 - 3.630" (80.39 - 92.20mm)	514-9-4A
514-9-6B	3.415 - 3.880" (86.74 - 98.55mm)	514-9-4A
514-9-6C	3.665 - 4.130" (93.09 - 104.90mm)	514-9-4B
514-9-6D	3.915 - 4.380" (99.44 - 111.25mm)	514-9-4B
514-9-6E	4.165 - 4.630" (105.79 - 117.60mm)	514-9-4B
514-9-6F	4.415 - 4.880" (112.14 - 123.95mm)	514-9-4C
514-9-6G	4.665 - 5.130" (118.49 - 130.30mm)	514-9-4C
514-9-6H	4.915 - 5.380" (124.84 - 136.65mm)	514-9-4C
514-9-6K	5.165 - 5.630" (131.19 - 143.00mm)	514-9-4C
514-9-6L	5.415 - 5.880" (137.54 - 149.35mm)	514-9-4C
514-9-6M	5.665 - 6.130" (143.89 - 155.70mm)	514-9-4C
514-9-6N	5.915 - 6.380" (150.24 - 162.05mm)	514-9-4C
514-9-6P	6.165 - 6.630" (156.59 - 168.40mm)	514-9-4C
514-9-6Q	6.415 - 6.880" (162.94 - 174.75mm)	514-9-4C
514-9-6R	6.665 - 7.130" (169.29 - 181.10mm)	514-9-4C
514-9-6S	6.915 - 7.380" (175.64 - 187.45mm)	514-9-4C

Diamond Stones, .312" (7.90mm) Height, Set of 4

514-9-14F Diamond Stones, 80 grit

3" (76mm) long set of 4, 90Ra (2.25um), stock removal .004-.007/min.



514-9-14R Diamond Stones, 80 grit

3 1/2" (89mm) long set of 4, 90Ra (2.25um), stock removal .004-.007/min. (.102 - .178mm)

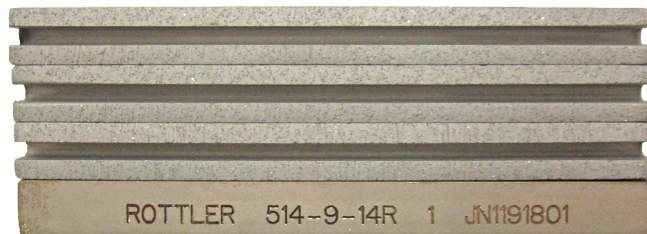

514-9-14W Diamond Stones, 140/170 grit

3" (76mm) long set of 4, 50-75Ra (1.25 - 1.875um)

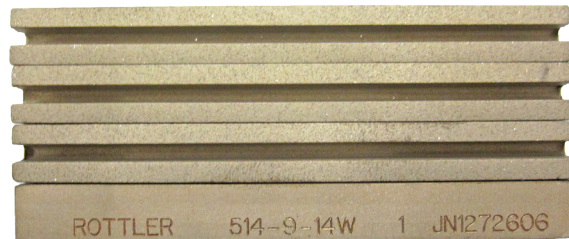

514-9-14K Diamond stones, 170/200 grit

3" (76mm) long set of 4, 45-60Ra (1.125 - 1.5um)

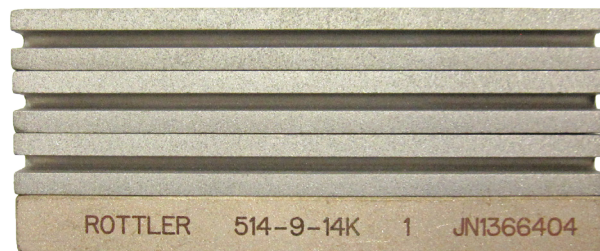

514-9-14M Diamond Stones, 170/200 grit
3 1/2" (89mm) long set of 4, 45-60Ra (1.125 - 1.5um)

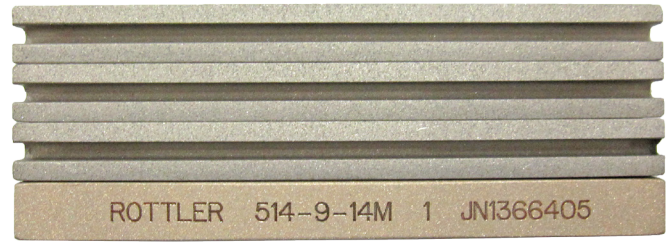

514-9-14J Diamond Stones, 270/325 grit
3" (76mm) long set of 4, 35-45Ra (.875 - 1.125um)

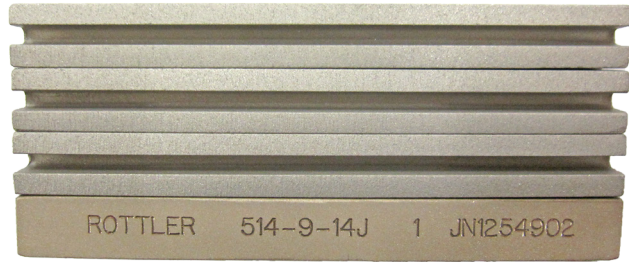

514-9-14T Diamond Stones, 270/325 grit
3 1/2" (89mm) long set of 4, 35-45Ra (.875 - 1.125um)



514-9-14Z Diamond Stones, 270/325 grit
4" (102mm) long set of 4, 35-45Ra (.875 - 1.125um)



514-9-14E Diamond Stones, 325/400 grit
3" (76mm) long set of 4, 24-30Ra (.6 - .75um)



514-9-14Q Diamond Stones, 325/400 grit

3 1/2" (89mm) long set of 4, 24-30Ra (.6 - .75um)

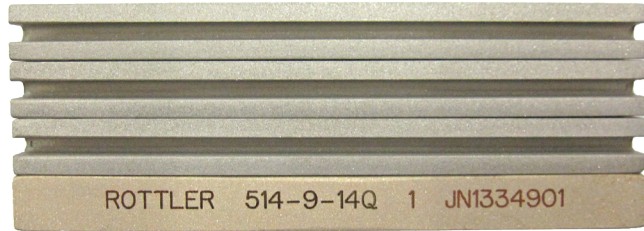

514-9-14X Diamond Stones, 325/400 grit

4" (102mm) long set of 4, 24-30Ra (.6 - .75um)

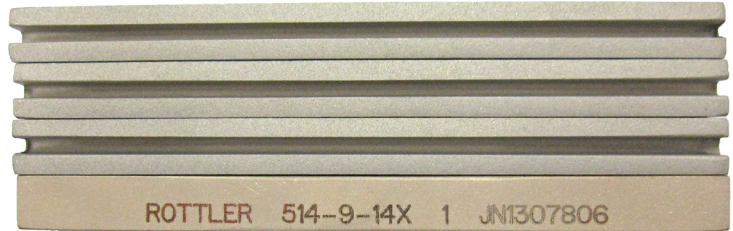

514-9-14V Diamond Stones, 400 grit

3" (76mm) long set of 4, 15-19Ra (.375 - .475um)

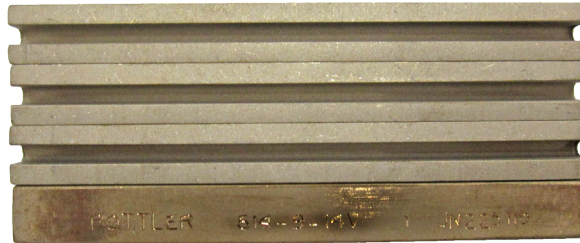

514-9-14C Diamond Stones, 500 grit

3" (76mm) long set of 4, 18-22Ra (.45 - .55um)

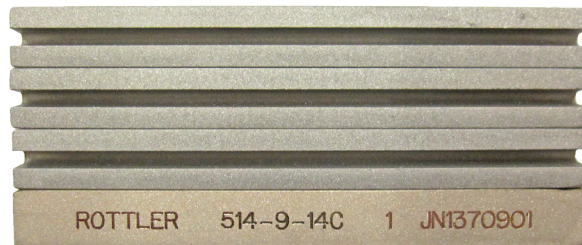

514-9-14P Diamond Stones, 500 grit

3-1/2" (89mm) long set of 4, 18-22Ra (.45 - .55um)



514-9-14D Diamond Stones, 325/400 grit

3" (76mm) long set of 4, 18-22Ra (.45 - .55um)
Special required for bores under 2.990" diameter
(75.94mm) .200" (5.1mm) Height



514-9-14U Diamond Stones, 500 grit

2 1/2" (64mm) long set of 4, 18-22Ra (.45 - .55um)

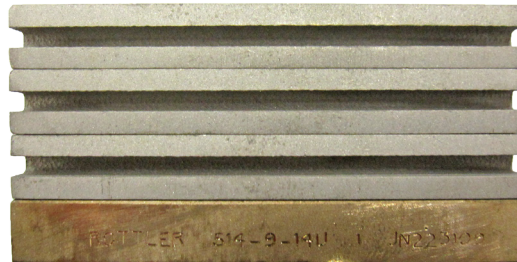

514-9-14L Diamond Stones, 550 grit

3" (76mm) long set of 4, 15-19Ra (.375 - .475um)



514-9-14N Diamond Stones, 550 grit

3 1/2" (89mm) long set of 4, 15-19Ra (.375 - .475um)



514-9-14G Diamond Stones, 600 grit

3" (76mm) long set of 4, 8-12Ra (.2 - .3um)



514-9-14S Diamond Stones, 600 grit
3 1/2" (89mm) long set of 4, 8-12Ra (.2 - .3um)



514-9-21G Diamond Stones, 800 grit
3" (76mm) long set of 4



514-9-21H Diamond Stones, 1000 grit
3" (76mm) long set of 4



514-9-21J Diamond Stones, 1200 grit
3" (76mm) long set of 4

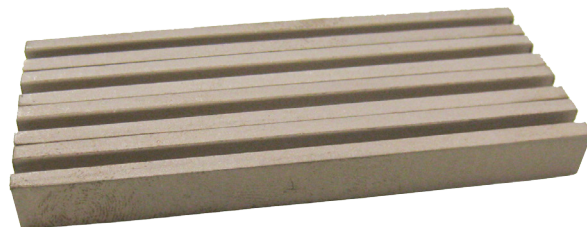

CBN Stones for Super Finishing with Rottler Precision 4 and 6 Stone Holder Hone Heads

514-9-35C CBN Stones, 320 grit
3" (76mm) long set of 4, for super finishing



514-9-35D CBN Stones, 400 grit
3" (76mm) long set of 4, for super finishing



514-9-35B CBN Stones, 600 grit
3" (76mm) long set of 4, for super finishing

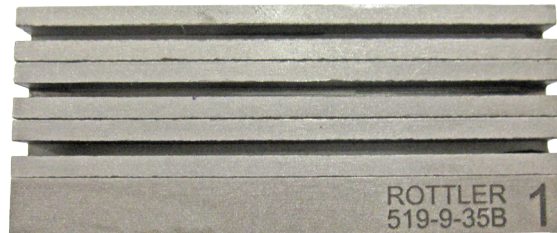

Brushes for Plateau Finishing with Rottler Precision 4 and 6 Stone Holder Hone Heads**514-9-14H Brushes, for Plateau Finishing**

.550" (14mm) height, 3 1/2" (89mm) long. Set of 4

Requires one or two size smaller stone holder compared to .312" (7.90mm) height diamond stone.

**514-9-14Y Brushes, for Plateau Finishing**

.395" (10mm) height, 3 1/2" (89mm) long. Set of 4

Requires same or one size smaller stone holder compared to .312" (7.90mm) height diamond stone.

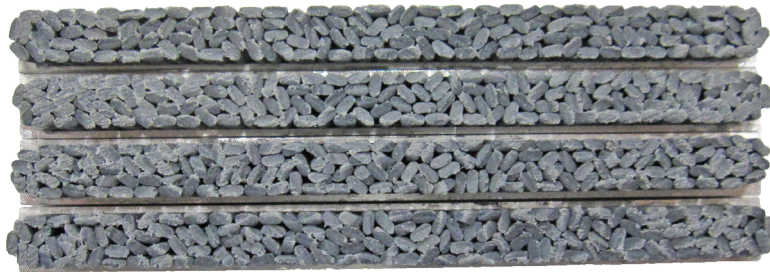

514-9F Extra Large Precision Heavy Duty 4 Stone Holder Hone Head Assembly Parts

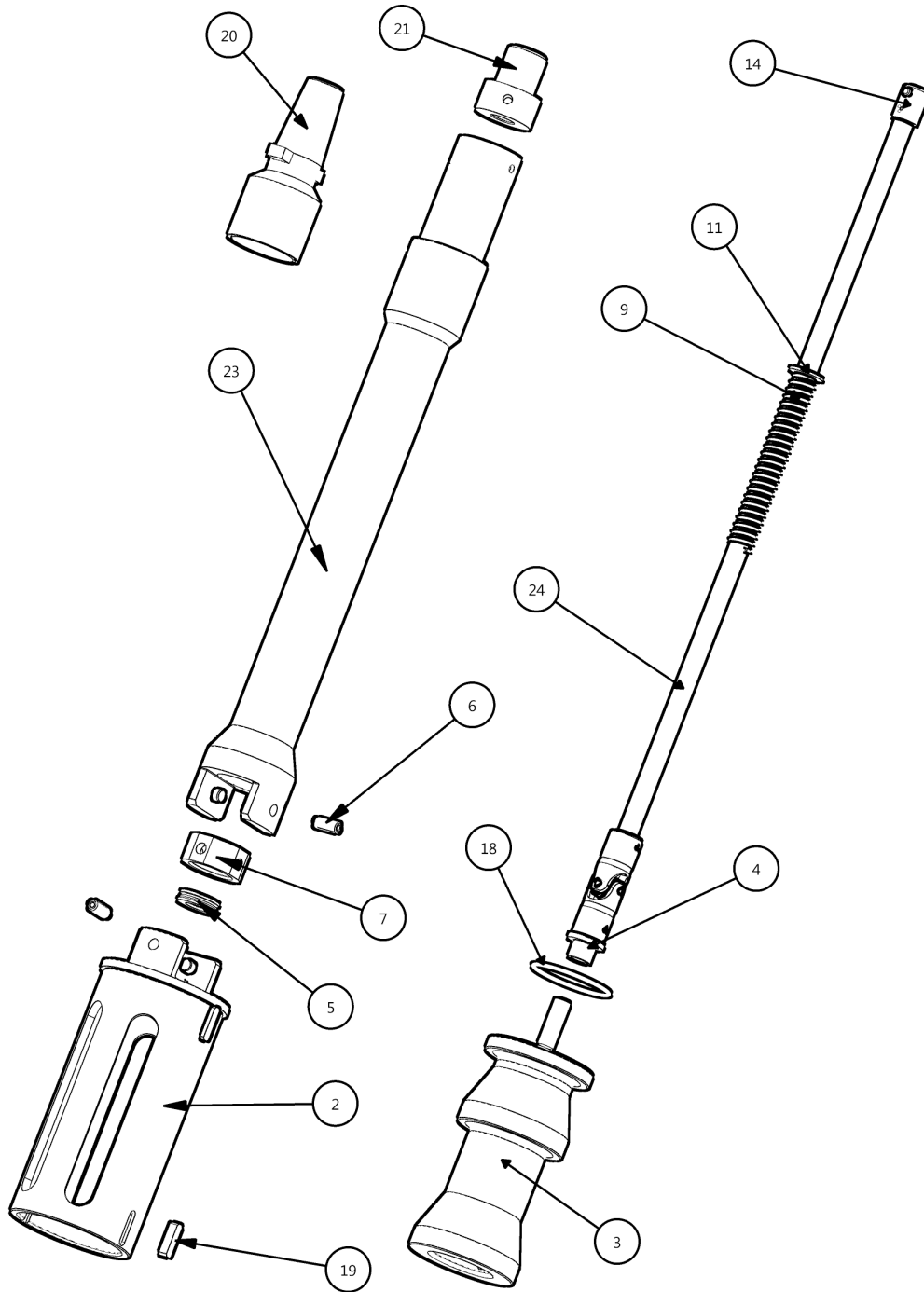

EXTRA LARGE HONE HEAD ASSEMBLY PARTS LIST			
ITEM	PART NUMBER	DESCRIPTION	QTY
2	514-9-10B	BODY	1
3	514-9-7C	CONE ROD	1
4	514-9-8A	UNIVERSAL NUT ASSEMBLY	1
5	514-7-82F	THRUST BEARING	1
6	514-5-66E	PIVOT PIN 5/16 X 3/4 PULL OUT STYLE	4
7	514-7-80G	PIVOT RING	1
9	514-5-72	SPRING	1
11	100-19	WASHER	1
14	514-6-44	DRIVE COUPLER	1
18	514-8-9B	O-RING BUMPER	1
19	6062	LOCATOR KEY	2
20	514-13-49	KWIK SWITCH ADAPTOR	1
21	514-7-81Z	CONNECTOR	1
23	514-7-81H	DRIVE YOKE	1
24	514-7-81N	ADJUSTING SHAFT	1

514-9-4D Sleeve Assembly Parts

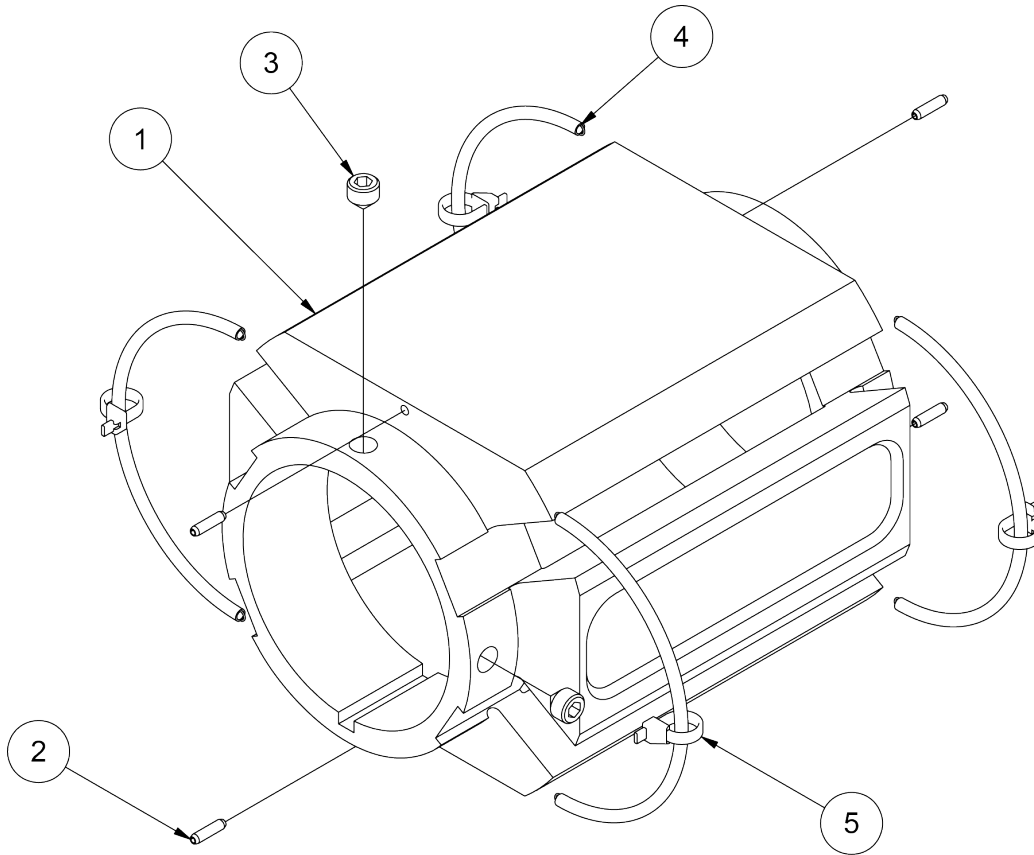

514-9-4D SLEEVE ASSEMBLY - EXTRA LARGE H.D. HONE HEAD			
ITEM	QTY	PART NUMBER	DESCRIPTION
1	1	514-9-3D	EXTRA LARGE H.D. HONE SLEEVE
2	4	MF-217	1/8 x 1/2 Roll Pin
3	2	514-7-83D	3/8-24UNF x 3/8" LG. CONE POINT SET SCREW
4	4	514-7-83E	GARTER SPRING
5	4	6147D	TYRAP, ELECTRICAL

514-9-25 Series Stone Holder Parts

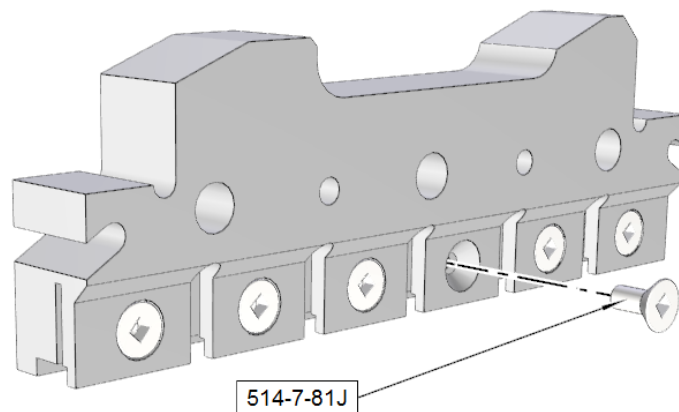

514-9-25 Series Stone Holder Size Chart

Stone Set #	Size Range
514-9-25A	6.1 - 6.4" (155 - 163mm)
514-9-25B	6.3 - 6.6" (160 - 168mm)
514-9-25C	6.6 - 6.9" (168 - 175mm)
514-9-25D	6.9 - 7.2" (175 - 183mm)
514-9-25E	7.2 - 7.5" (183 - 191mm)
514-9-25F	7.5 - 7.8" (191 - 198mm)
514-9-25G	7.8 - 8.1" (198 - 206mm)
514-9-25H	8.1 - 8.4" (206 - 213mm)
514-9-25J	8.4 - 8.7" (213 - 221mm)
514-9-25K	8.7 - 9.0" (221 - 229mm)
514-9-25L	9.0 - 9.3" (229 - 236mm)
514-9-25M	9.3 - 9.6" (236 - 244mm)
514-9-25Q	9.6 - 9.9" (244 - 252mm)
514-9-25R	9.9 - 10.2" (252 - 260mm)
514-9-25S	10.2 - 10.5" (260 - 267mm)
514-9-25T	10.5 - 10.8" (267 - 275mm)
514-9-25U	10.8 - 11.1" (275 - 283mm)
514-9-25N	10.9 - 11.2" (276mm - 284mm)
514-9-25P	11.67 - 11.98" (296mm - 304mm)

Special Hone Head Single Stage, 12 Stone**514-9N Hone Head, Single Stage (12 Stone)**

3.9" - 4.375" (99.06MM - 111.125MM), H-70



Assembly Image and Parts List are unavailable at this time.

Please visit the service tab of our web page at [Send a Service Request www.rottlermfg.com](http://www.rottlermfg.com) or contact the Rottler Factory Service at service@rottlermfg.com for assistance and your service request.

You may also call Rottler at 1-800-452-0534 or 1-253-872-7050

Please ensure you have the Machine Model and Serial Number available when contacting Rottler for Service

110-171-01 Single Stage Diamond Stones

.0781" Tall (19.83MM), 600 Grit Set of 12

**110-171-02 Single Stage Diamond Stones**

.0781" Tall (19.83MM), 1200 Grit, Set of 12

**110-171-03 Single Stage Diamond Stones**

.0781" Tall (19.83MM), (325/400 Grit) - Set of 12



Special Hone Head, 1.97" - 2.32" (50mm - 59mm) , 6 Stone Holder**LO-6568-161 Hone Head, Single Stage (6 Stone)**

1.97" - 2.32" (50MM - 59MM)

Image Currently Unavailable

Assembly Image and Parts List are unavailable at this time.

Please visit the service tab of our web page at Send a Service Request www.rottlermfg.com or contact the Rottler Factory Service at service@rottlermfg.com for assistance and your service request.

You may also call Rottler at 1-800-452-0534 or 1-253-872-7050

Please ensure you have the Machine Model and Serial Number available when contacting Rottler for Service

110-174-01 Diamond Stones

.25 x .640 x 4.25 (6.35MM x 16.26MM x 107.95MM)

(325/400 Grit) - Set of 5

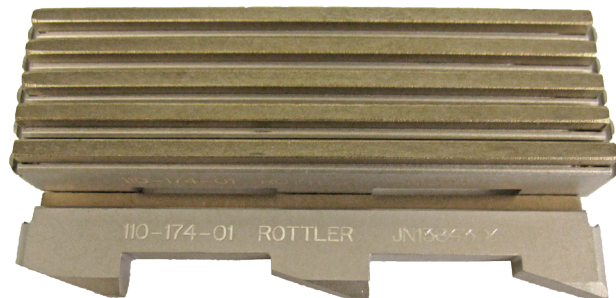

Special Hone Head, 1.69" - 1.93" (43 - 49mm) , 5 Stone Holder**LO-6568-160 Hone Head, Single Stage**

(5 Stone) 1.69" - 1.93" (43MM - 49MM)



Image Currently Unavailable

Assembly Image and Parts List are unavailable at this time.

Please visit the service tab of our web page at [Send a Service Request www.rottlermfg.com](http://www.rottlermfg.com) or contact the Rottler Factory Service at service@rottlermfg.com for assistance and your service request.

You may also call Rottler at 1-800-452-0534 or 1-253-872-7050

Please ensure you have the Machine Model and Serial Number available when contacting Rottler for Service

110-173-01 Diamond Stones

.25 x .5 x 4.25 (6.35MM x 12.7MM x 107.95MM)
(325/400 Grit) - Set of 5



Special Stones for Finishing Aluminum Silicone Cylinders
(Refer to bulletin No. 284) Requires Rottler Precision 4 or 6 Stone Holder Hone Heads

514-9-18P Special Red Finish Diamonds
For Final Sizing (set of 4)

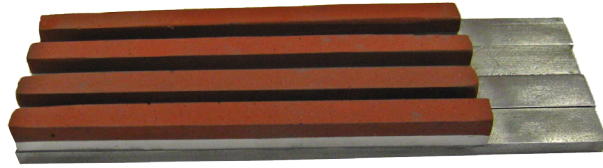

514-9-18N Silicone Abrasive Exposing Stones
For Removing Aluminum (set of 4)



514-9-21 Polishing Felt Pads
For use with 514-9-21F silicon paste. (set of 4)



514-9-21F Silicone Paste
For use with 514-9-21 Polishing felt pads



Optional Measuring Equipment

201 Mitutoyo Surface Tester Surftest 201

Sold as complete unit only.



514-8-27 Stone Depth Scale and Holder Assembly (inch)

514-8-27F Stone Depth Scale and Holder Assembly (metric)

Both items sold as complete assemblies only.

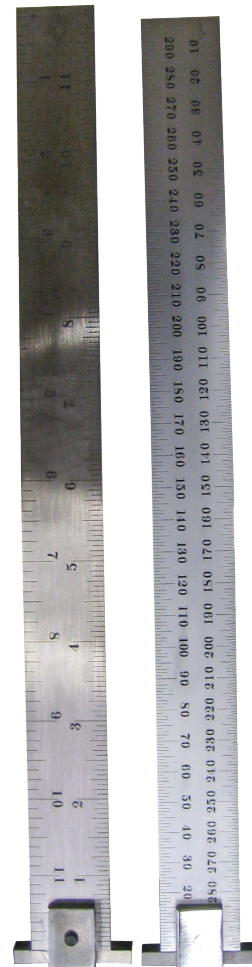
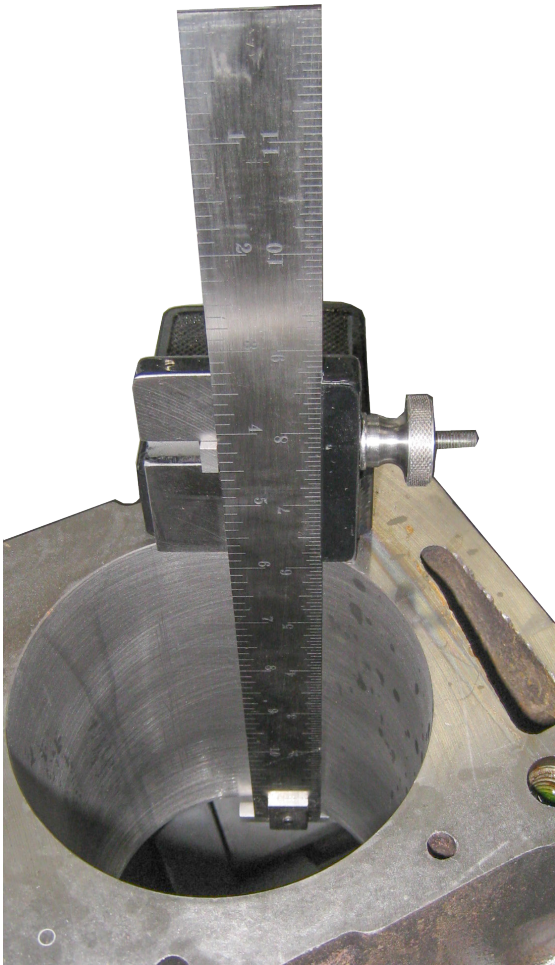

Adapter for Pin Honing Mandrels

514-9V Adapter Parts

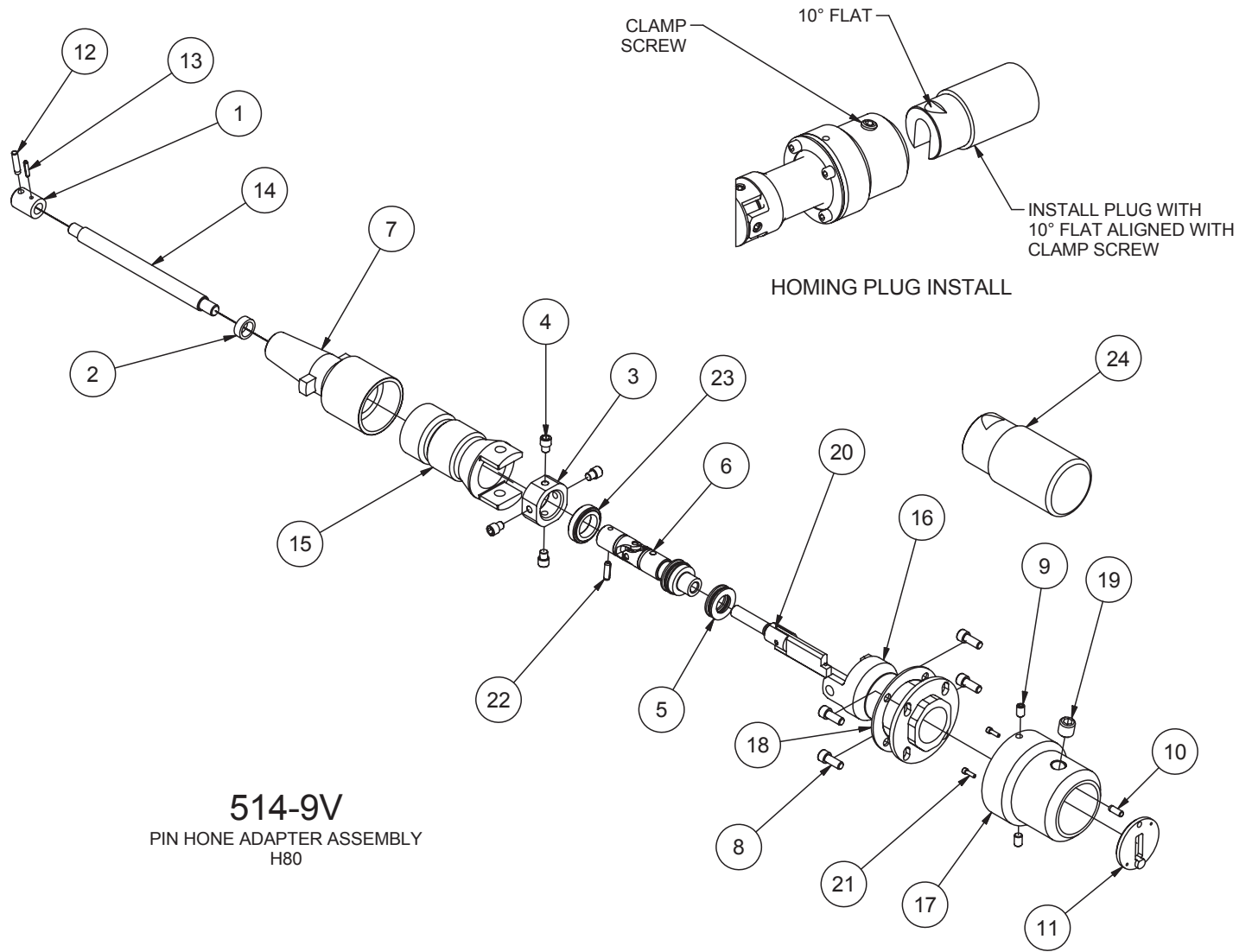

514-9V
PIN HONE ADAPTER ASSEMBLY
H80

514-9V PIN HONE ADAPTER ASSEMBLY - H80			
ITEM	QTY	PART NUMBER	DESCRIPTION
1	1	514-6-44	DRIVEN COUPLING - HONE #2
2	1	514-7-80T	OIL LITE BUSHING
3	1	514-10-6	PIVOT BLOCK UNIVERSAL JUNIOR PERCISION HONE HEAD
4	4	514-10-10	PIVOT SCREW
5	1	514-7-82F	THRUST WASHER
6	1	514-10-5B	U-JOINT ASSEMBLY - PIN HONE ADAPTER - H80
7	1	514-13-49	KWIK SWITCH TAPER
8	4	MF-13	S.H.C.S.1/4 - 20 UNC - 5/8
9	2	514-10-1E	1/4-28UNF x 3/8" LONG SOCKET FLAT POINT SET SCREW
10	1	MF-196	3/16" x 1/2" LG. DOWEL PIN
11	1	514-10-3D	BACKING PLATE, PIN HONE ADAPTER ASSEMBLY
12	1	MF-198A	3/16 x 7/8 Dowel Pin
13	1	MF-218	1/8 x 5/8 Roll Pin
14	1	514-10-20C	ADJUSTING SHAFT - PIN HONE ADAPTER ASSEMBLY
15	1	514-10-20D	YOKE DRIVE TUBE, PIN HONE ADAPTER - H75
16	1	514-10-1B	UPPER BODY, PIN HONE ADAPTER ASSEMBLY - H80
17	1	514-10-1C	LOWER BODY, PIN HONE ADAPTER ASSEMBLY - H80
18	1	514-10-1D	CLAMP PLATE, PIN HONE ADAPTER ASSEMBLY - H80
19	1	6855P	1/2-13UNC x 1/2" LONG SOCKET FLAT POINT SET SCREW
20	1	514-10-3E	ACTUATOR ASSEMBLY, PIN HONE ADAPTER ASSEMBLY - H80
21	2	MF-84D	4-40UNC x 3/8" LG. S.H.C.S.
22	1	MF-223C	3/16" X 5/8" LG. ROLL PIN
23	1	514-10-1F	NUT, THRUST BEARING - PIN HONE ADAPTER - H80
24	1	514-10-1G	HOMING PLUG, PIN HONE ADAPTER - H85