



F8M & F7M Series

BORING MACHINE

MACHINE SERIAL NUMBER

OPERATIONS AND MAINTENANCE
MANUAL



MANUFACTURED BY:

ROTTLER MANUFACTURING COMPANY
8029 South 200th Street
Kent Washington 98032
USA

Phone: (253) 872-7050
Fax: (253) 395-0230
Website: <http://www.rottlermfg.com>

NOTE: WHEN ORDERING REPLACEMENT PARTS,
PLEASE GIVE THE MODEL AND SERIAL NUMBER.

ORDER BY PART NUMBER.
THERE IS A MINIMUM ORDER OF \$25.00

CONTENTS:

Introduction / Safety / Installation	1
Introduction	1.1
Description	1.1
Limited Warranty	1.1
Safety Information	1.2
Electrical Power	1.2
Machine Operator	1.2
Emergency Procedures	1.3
Machine Installation	1.3
Location	1.3
Unpacking	1.3
Shipping Hold Down Bolt	1.3
Leveling	1.4
Air Supply	1.4
Power Supply	1.5
Grounding	1.5
Electrical Hook-up Illustration	1.6
 Control Definitions	 2
Master Power On/Off Switch	2.1
Spindle Rotation Button	2.1
Spindle RPM knob	2.1
Float/Neutral/Clamp switch	2.1
Centering Hold button	2.1
Up button	2.1
Down button	2.2
Manual/Auto Retract switch	2.2
Feed Rate – Per Revolution	2.2
Vertical Home Sensor	2.2
Vertical Home Switch (early machines)	2.2
Vertical Stop Collar	2.3
Depth Switch	2.3
Spindle Proximity Sensor	2.3
Manual Handwheel	2.3
Depth Stop Collar	2.3
Emergency Stop Button	2.3
Centering Knob	2.3
Control Panel Illustration	2.4
Machine Control Illustration	2.5
 Operating Instructions	 3
Loading In-Line Cylinder Blocks	3.1
Block Clamps	3.1
Micrometer	3.1
Centering	3.2
Centering Fingers Removal and Replacement	3.2
Centering Accuracy Check	3.2
Boring	3.2
Manual Handwheel	3.2
Manual Retract	3.2
Auto Retract	3.3
Boring Feeds and Speeds	3.3
Gold Square	3.3
Purple Square	3.3
Black Triangle 1/64" Radius	3.3
Black Triangle 1/32" Radius	3.4

Gold Triangle 1/64" Radius.....	3.4
Gold Triangle 1/32" Radius.....	3.4
Boring Large Truck Blocks.....	3.4
Optional Capacity to 8" Diameter.....	3.5
Install and Remove Toolholders	3.5
Install and Remove Cutterheads	3.5
Micrometer Calibrating Illustration	3.6
Maintenance	4
Lubrication.....	4.1
Vertical Ballscrew.....	4.1
Vertical Ballscrew Bearings.....	4.1
Outer Spindle	4.1
Inner Spindle – Oiler Setting	4.1
Clamp arms	4.1
Air Adjustments.....	4.2
Float	4.2
Tilt.....	4.3
Pressure Switch	4.4
Lubrication Illustration	4.5
Outer Spindle Adjustment.....	4.6
Inner Spindle Adjustment.....	4.7
Home Switch Adjustment (early machines)	4.8
Home Switch Adjustment Illustration	4.9
Home Sensor Adjustment.....	4.10
Spindle Index Sensor Adjustment.....	4.11
Spindle Drive Belt Removal/Replacement and adjustment	4.12
Accessing Spindle Drive Belt	4.12
Removing Spindle Drive Belt	4.12
Installing Spindle Drive Belt	4.12
Belt Adjustment	4.12
Excessive Loads	4.13
Thrust Overload.....	4.13
Spindle Overload.....	4.13
Vertical Drive Housing	4.14
Accessing Vertical Drive Housing and Mechanical hand Feed Housing	4.14
Mechanical Hand Feed Gear Housing.....	4.14
Removing Vertical Drive Housing	4.14
Replacing Vertical Drive Belt.....	4.14
Adjusting Vertical Drive Belt.....	4.14
Replacing Vertical Drive Housing.....	4.15
Inner Spindle Removal.....	4.15
Upper Housing Removal.....	4.15
Outer Spindle Removal.....	4.15
Troubleshooting	5
Spindle Light Blinking.....	5.1
Vertical Light Blinking.....	5.1
No Spindle Rotation	5.1
No Vertical movement.....	5.2
No Tilt.....	5.3
Spindle Falling When Power is Off	5.3
Chatter in Bore	5.3
Bore Out of Round	5.3
Taper in Bore	5.3
Spindle Motor Noisy	5.4
Vertical Motor Noisy.....	5.4

Machine Parts Breakdown	6
Front/Right Side View	6.1
Air Logic Diagram	6.2
Electronic Enclosure	6.3
Spindle Base Assembly Illustration.....	6.4
Spindle Base.....	6.5
Spindle Base Clamp System	6.6
Control Panel	6.7
Spindle Section Type 1	6.8
Spindle Section Type 2	6.9
Vertical Drive Assembly (early machines)	6.10
Vertical Drive Assembly	6.11
Upper Housing Driven Sprocket	6.12
Drawtube Assembly	6.13
Upper Housing Drive Sprocket	6.14
Block Clamp Assembly	6.15
Tools	6.16

Introduction:

This manual is arranged in sections as listed in the table of contents.

It is required that the new user of the F8M-F7M Boring Machine read this manual before operation. Pay close attention to the sections concerning safety.

The Controls Definition and Operating Instructions chapters should be read very carefully in order to familiarize the user with the actual button pushing sequences required to carry out a job. These chapters in the manual should be considered an introduction. As the operators of the F8M-F7M series machine gains experience with using different functions of the machine, complicated setups and programs will make more sense.

The rest of the manual contains information and part number reference on fixtures, cutting tools, and machine maintenance. The operator needs to read and become familiar with these areas as well

Description:

The model F8M-F7M is a precision, single point, high speed boring machine. The F8M-F7M can be equipped with tooling and accessories for re-boring most American passenger car and truck engines, In-lines as well as 60 and 90 degree V-types.

The F8M-F7M machines can be easily tooled to machines a wide range of engines, including European and Asian.

The machine is designed to maintain the alignment of cylinder bores to the Pan Rails and Main Bearing bore locations, as was done in the original factory machining. This overcomes the many inaccuracies and out-of-alignment problems associated with the clamping of portable boring bars to the cylinder head surface of the blocks.

Convenient controls, fast block clamping, air floated Spindle Base positioning and clamping, means considerable savings in floor to floor time and operator involvement.

Change over or re-setting time required to set up V-type or In-Line engines is a minimum, making this machine highly suited to the jobber shop where engines cannot be run through in model lots.

Limited Warranty:

Rottler Manufacturing Company Model F8M-F7M parts and equipment is warranted as to materials and workmanship. This limited warranty remains in effect for one year from the date of delivery, provided the machine is owned and operated by the original purchaser and is operated and maintained as per the instructions in the manual.

Tools proven to be defective within the warranty period will be repaired or replaced at the factory's option.

We accept no responsibility for defects caused by external damage, wear, abuse, or misuse, nor do we accept any obligation to provide compensation for direct or indirect costs in connection with cases covered by the warranty.

Freight charges on warranty items (non-air shipment only) will be paid by Rottler Manufacturing for a period of 60 days only from the date of installation or set-up by a qualified service technician or sales representative.

Freight charges after the 60 day period are the customers responsibility.

Safety Information:

CAUTION: *This machine is capable of causing sever bodily injury!*

The operator of the F8M-F7M should be a skilled machinist craftsman who is well versed in the caution, care, and knowledge required to safely operate metal cutting tools. **Eye protection must be worn at all times by the operator and all other personnel in the area of the machine.**

The operator should be extremely cautious when working around the cutting tool area.

When boring the machine is capable of throwing metal chips over 1- feet from the cutting area. **Always use the guards.**

The F8M-F7M operates under computerized control and, as is all computerized equipment, and is susceptible to extraneous electrical impulses internally for externally produced. The machine may make moves out of the operator control at any time. The operator should work in and around the machine with caution at all times.

The operator and nearby personnel should be familiar with the location and operation of the Emergency Stop Button.

Electrical Power:

Make sure all electrical equipment has the proper overload protection. The F8M-F7M should have **a fully isolated** power supply to prevent damage and uncontrolled movement of the machine. If the F8M-F7M is on the same power lines that are running to other electrical equipment (grinders, welders, and other AC motors) electrical noise can be induced into the F8M-F7M electrical system. Electrical noise can cause the controller to see false signals to move. Not supplying a fully isolated supply to the machine may void factory warranty. Refer to the Power supply section later in this chapter for voltage and amperage requirements of the F8M-F7M.

Machine Operator:

The operator of the F8M-F7M should be a skilled machinist craftsman who is well versed in the caution, care, and knowledge required to safely operate metal cutting tools. **Eye protection must be worn at all times by the operator and all other personnel in the area of the machine.**

If the operator is not a skilled machinist he/she must pay strict attention to the Operating Instructions outlined in this manual, and get instruction from a qualified machinist in both production and operation of this machine.

The F8M-F7M machines have the following areas of exposed moving parts that you must train yourself to respect and stay away from when they are in motion:

1. **Tool Sharpening** – Must be done with care and dexterity to get good bore results, be alert to the light pressure required for tool sharpening.

CAUTION: *Exposed diamond wheel is a potential hazard to your hands, fingers, and face. Eye protection must be worn when working in this area.*

2. **Cutting Too l Area** – Any operation involving hands in the cutter head area, such as inspection or alignment of the cutter head or tools, changing Centering Fingers, tool insertion, and removal, cutter head changes, and size checking etc. requires the machine to be in Neutral.
3. **Machining** – Eye protection must be worn during all operations of the machine. Hands must be kept completely away from the cutter head. All chip guards must be in position during machine operations.

4. **Work Loading and Unloading** – Carefully develop handling methods of loading and unloading work pieces so that no injury can result if hoist equipment or lift connection should fail. Periodically check lift components for damage that may cause failure of Block Handler Assembly. Lifting Eye can eventually fail if the eye is reset in line with the 502-1-80 lift channel. ***Eye must be at a right angle.***
5. Machine Maintenance – Any machine adjustment, maintenance or parts replacement absolutely requires a complete power disconnection from the machine, ***this is an absolute rule.***

Emergency Procedure:

Assuming one of the following has occurred: tool bit set completely off size, work piece or spindle base not clamped, spindle is not properly centered, these mistakes will become obvious the minute the cut starts

PRESS THE EMERGENCY STOP BUTTON (on the front control panel) IMMEDIATELY!

Find out what the problem is; return the spindle to its up position without causing more damage. To restart the machine, turn the Emergency Stop Button CW until the button pops out. Make sure the button has been depress for at least 1 ½ minutes or the drive will not have time to reset and they will not function.

Be alert to quickly stop the machine in the event of a serious disruption of the boring process either at the top or bottom of the bores.

“REMEMBER” metal cutting tools have the speed and torque to severely injure any part of the human body exposed to them.

Machine Installation:

Location:

The productivity of the F8M-F7M will depend a great deal on the proper initial installation. Pay particular attention to the means by which work pieces are lifted into and out of the machine as well as the material handling to and from other operations in your shop. The proper loading arrangements and work location for your F8M-F7M is extremely important.

A slow travel (6' to 10' per minute) power hoist, operated from either a bridge or jib crane arrangement works very well. A 1000 lb. Is generally adequate for lifting most engine blocks. An air hoist with speed control makes an ideal method for fast, efficient loading and unloading.

For shops where large production runs are anticipated, the work pieces should be loaded and unloaded directly from a conveyer. If this is not the case, we suggest you pay considerable attention to the crane so that it covers an adequate area to allow the operator to back up and remove work pieces without creating a cluttered, dangerous work area.

Unpacking:

Use care when removing the crate materials from the machine. Be careful not to use force on any part of the machine.

Remove the Toolbox, Parallels and optional equipment form the machine. Completely clean these articles along with the rest of the machine with solvent, rust inhibitor was applied at the time of shipment. Any of the rust inhibitor left on the machine will allow Cast Iron dust to build up and cause premature wear to the machine.

Shipping and Hold Down:

Remove the sheet metal cover from the rear of the Spindle Base by removing the four (4) round head Allen screws.

Pull out the Cotter Key from the Castle nut located in the center of the Spindle Base and loosen the nut. Turn the machine on and place it in Neutral. Hand tighten the nut to take out all the play in the Roller Key assembly. Loosen the nut approximately 1/12 of a turn. Place the Cotter Key in the nearest slot of the Castle Nut. Put the machine in Float and move the machine from side to side and remove the rust inhibitor that was placed under the Spindle Base. This may have to be done several time to remove all of the rust inhibitor.

Switch the machine to Clamp and check for proper operation of the clamp assembly. Check for proper release and movement when put back into Float.

Note: *Clamp cylinder rods should move a minimum of .200" when Spindle Base is clamped.*

Leveling:

Four square head bolts (504-1-12A), four jam nuts (502-1-12F), and four chamfered washers (502-1-12) are provided with the machine for leveling. Refer to the drawing on page 6.1. Screw the jam nuts all the way onto the bolts, insert the bolts at the base support points (corners). Screw the bolts in until they are just protruding from the bottom of the base casting. Lower the machine onto the washers, making sure the bolts seat into the chamfered area of the washers.

Using a precision level, level the upper table within .003" per foot in both directions. Make sure that the machine weight is equally supported at all four support points.

Air Supply:

It is very important that the air source for the F8M-F7M be moisture free. Water and oil in the air lines will result in early cylinder and valve failure as well as introducing moisture into the Iner spindle bearings. **The factory recommends installing a water trap at the machine.**

Attach a 100 P.S.I. air source to the main air intake located on the right hand side of the main rear enclosure.

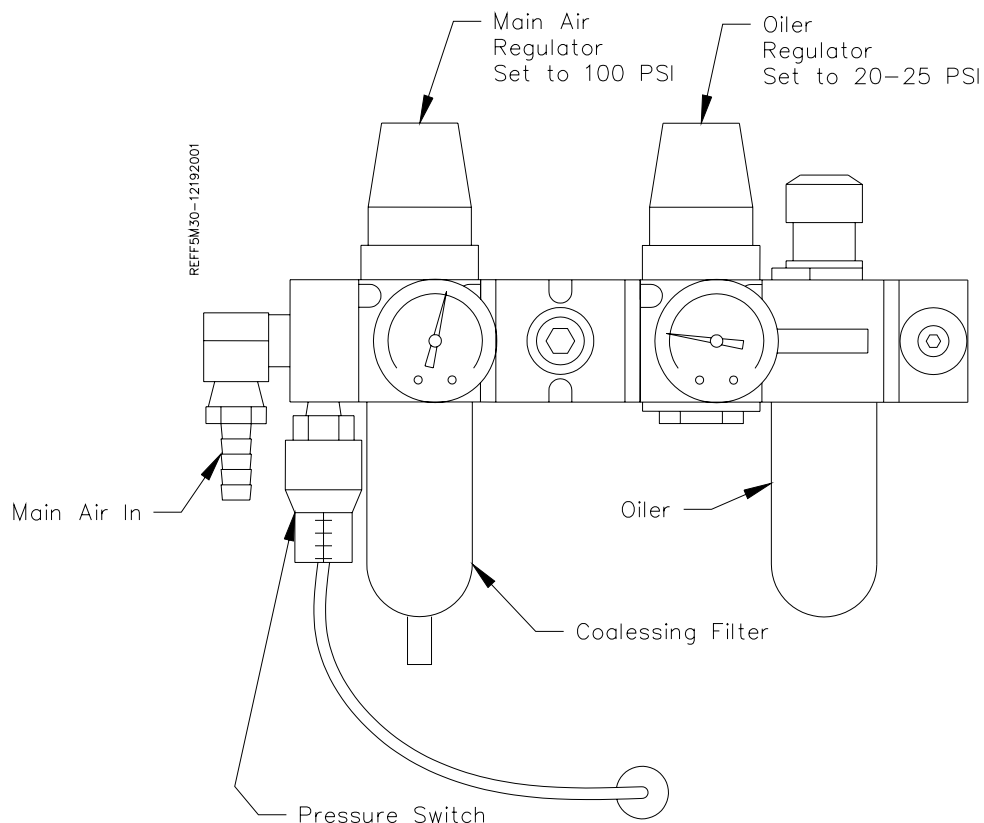

Power Supply:

This machine has the following power requirements:

208 to 240 VAC
Single Phase
50 or 60 Hertz
30 amps

See illustration below for correct connection of "measured" incoming power. Connect single phase wiring to the main rear enclosure, located on the right rear of machine base. The connection point for power is located inside the enclosure. The connection termination point is located on the left hand side of the electrical panel about half way up. Connect L1 to the grey terminal block, L2 (neutral) to the blue terminal block. Attach wire from the grounding rod to the second green and yellow terminal. **Important:** *Electrically connect in accordance with national and local electrical codes.*

Grounding:

This machine must be connected to a good earth ground rod. A 6 foot, 1/2" diameter, 15 OHM, Copper grounding rod driven into the earth next to the machines is preferred. Not providing a grounding rod could void factory warranty.

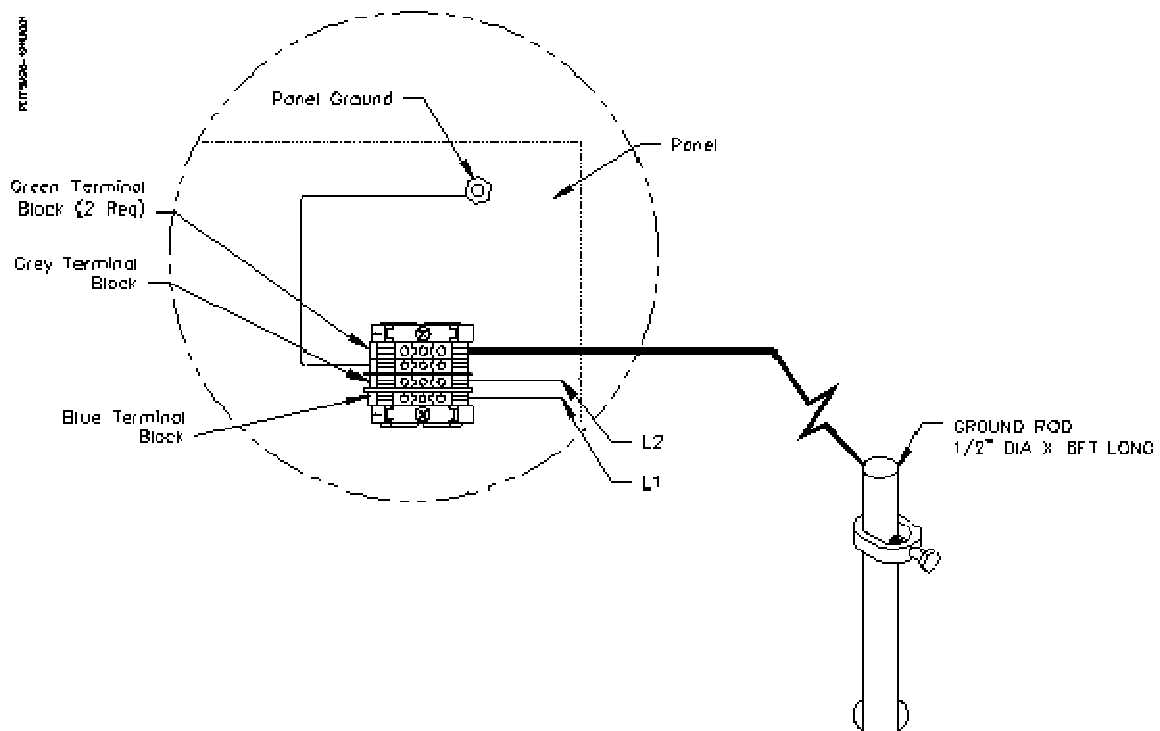

Electrical Enclosure:

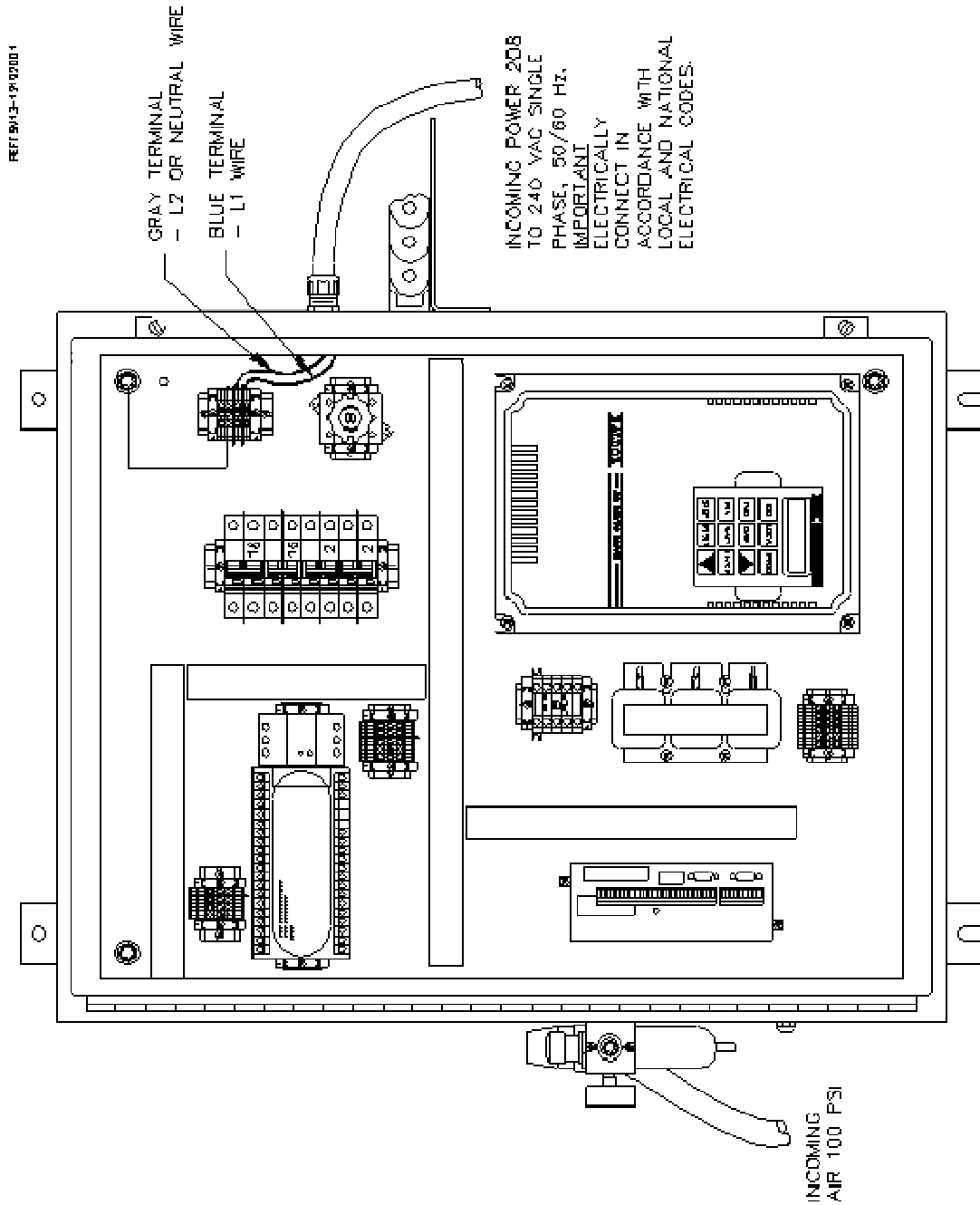

Control Definitions:

Master Power On/Off Switch:

This switch is located in the large electrical enclosure on the back of the machine. After turning off the machine, you must wait at least 1 1/2 minutes to turn it back on. The Spindle and Vertical amplifiers require time to power themselves down. This switch must be turned off in order to open the electrical enclosure door.

Spindle Rotation:

This button is used to turn the Spindle rotation on and off. When the Spindle Rotation button is pressed the spindle will rotate in a clockwise direction at the speed indicated by the Spindle RPM potentiometer. Pressing this button while the spindle is rotating will cause the spindle rotation to stop. Use extreme caution when starting the spindle as it will start when the machine is in Float or Neutral.

The Spindle will not start if the machine is in Rapid Up or Down travel.

If the Spindle Rotation button is flashing, the Spindle amplifier has faulted and must be reset. This can be done by turning the power off at the rear enclosure or by pressing the reset button located on the Spindle amplifier keypad. If the amplifier continues to fault, contact the factory for further assistance.

Spindle RPM:

This potentiometer sets the speed at which the spindle will rotate when Spindle Rotation button is pressed. The speed of the spindle is from 100 to 1200 RPM.

Float/Neutral/Clamp:

This switch provides control for the clamping system of the spindle base. The following is an explanation of the three switch positions. This is a mechanically activated switch and is not monitored by the electronic control of the machine.

Clamp:

CAUTION: *When boring and at all times the spindle is running this switch MUST be in the CLAMP position.*

The Clamp holds the spindle base to the tabletop when the machine is boring. The switch must be released from the Clamp position to move the spindle base horizontally.

Float:

When the switch is in the Float position the spindle unit is unclamped and is floating on a cushion of air. The Float position is used to move the machine horizontally and to manually center the machine using the Manual Center knob.

Neutral:

The neutral position is between the Clamp and Float position of the switch. When the switch is in the Neutral position the spindle base is unclamped and the Float is turned off. The Neutral position is used to center in a cylinder using a dial indicator.

Centering Hold:

This button is pressed and held to prevent the spindle from rotating while the centering knob is being turned.

CAUTION: *If this button is pressed while the spindle is on, it will stop rotating. When the button is released the spindle will start turning again at the same RPM it was previously running.*

Up:

This button has two functions. When the Spindle is not rotating; pressing the Up button will initiate rapid Up travel. Rapid Up travel will continue until the spindle has reached its Home position. To stop the Rapid Up travel press the Up button again. Rapid travel is set at 60 inches per minute.

When the Spindle is rotating, pressing the Up button will start the Spindle feeding up at the rate specified by the Feed Rate knob. Feed will continue Up until the Home Switch is reached.

Down:

This button has two functions. When the spindle is not rotating; pressing the Down button will initiate rapid Down travel. Rapid Down travel will continue as long as the button is being pressed. Releasing the button will stop the Rapid Down travel. Rapid down travel will also stop if the Depth Switch is depressed. Rapid Down travel is set at 60 inches per minute.

When the Spindle is rotating, pressing the Down button will start the Spindle feeding down at the rate specified by the Feed Rate knob. Feed will continue until the Depth Switch is reached.

Manual/Auto Retract:**Manual:**

When the switch is in the Manual position the spindle must be retracted from a cylinder manually by pressing the up button. This position should be used when you do not want the exact position of the spindle, in reference to the cylinder to change.

CAUTION: *When using the Blind stub bar on the F8M-F7M you need to be in the manual mode until after you center in the bore. If you are in the auto mode the spindle base will tilt when the up button is pressed, causing the machine to go off center before boring. If you want to stay in the auto mode after centering, the spindle must be retracted manually using the hand wheel.*

Auto:

When the switch is in the Auto position the spindle is automatically retracted out of the cylinder after the bore is complete to the Vertical Home position.

After a cylinder bore is complete and the Depth switch has been actuated the cutterhead will go through a 2-second washout period. When the washout is complete the cutterhead will rotate at its creep speed to the 3 O clock position. The Spindle Base will tilt the tool to clear the cylinder wall and retract to its Vertical Home position.

Anytime the Up button is pressed or activated by the program (when in the Auto mode) the Spindle base will tilt. This tilt can be measured off of the spindle base and should be approximately .0025". Refer to Tilt Adjustment in the Maintenance section of this manual.

Feed Rate - Per/Revolution:

The Feed Rates of the F8M-F7M are selectable from .0015" to .008". Feed rates are the speed at which the spindle will travel down while boring a cylinder. The Feed Rate has a direct 'per revolution' relationship to the spindle speed.

Vertical Home Sensor:

The Vertical Home Sensor is located on the top lid of the spindle belt housing. This switch is a electronic proximity switch that is activated by the stop collar at the top of the vertical ballscrew. When the Home switch is activated the machine will not Rapid or Feed up. See Home Sensor in the Maintenance section of this manual for adjustment procedures.

Vertical Home Switch: (very early machines)

The Vertical Home Switch is located behind the front control panel. The switch is activated by a ramp in the spindle key way. When the Home switch is activated the machine will not Rapid or Feed up. See Home Switch in the Maintenance section of this manual for adjustment procedures.

Vertical Stop Collar:

The Vertical Stop Collar is located at the top of the Vertical Ballscrew. This should be checked periodically to make sure both the set screws are locked down tight. If the set screws are not tight it is possible for the machine to over travel the ballscrew. This could cause severe mechanical damage to the machine as well as harm the operator and others around.

Depth Switch:

The Depth Switch is located on the top of the Spindle Base where the Spindle enters it. When the Depth Switch is activated Vertical down travel is stopped. If the machine was in the Feed mode when the switch was activated Manual/Auto Retract is initiated. When in rapid mode the travel is stopped and any further down travel is inhibited.

Spindle Proximity Sensor:

The Spindle Proximity Sensor is located on the back right hand side of the belt housing. When the sensor is activated a red light on the back of it will come on. This let's the computer control know the cutter is indexed to the correct position and will allow Auto Retract. If the index sensor is not seen in four revolutions the cutterhead will stop and the machine will have to be manually retracted from the bore.

Manual Handwheel:

The Manual Handwheel is located at the base of the Vertical ballscrew to the right hand side of the machine. This is used for precision counter boring and sleeve facing etc.

CAUTION: *The Handwheel is not separate from the power vertical drive and extreme care should be taken not to activate the power feed anytime the Handwheel is being used. Serious injury could result.*

The standard procedure to operate the hand feed is to Rapid travel close to the cutting point. Start the Spindle at the desired speed and rotate the Handwheel to make the cut. Then power feed the Spindle back to the Vertical Home position.

There is an optional dial indicator available for use on the Stop Collar. Use this indicator to measure your manual cut depths. Zero out the indicator when the cutting tool is at the top or surface of your cut. The depth you are cutting is then read out on the indicator.

Depth/Stop Collar:

The Depth/Stop collar is located around the Upper part of the spindle. The Collar is used to set the stop point of the cylinder bores. This collar activates the Depth switch; this collar must be adjusted and set before the machine crashes at the bottom of the bore. Check the bottom set depth carefully to ensure the cutterhead will not contact any obstructions.

Emergency Stop Button:

The Emergency Stop Button is a large Red button located at the lower right of the front control panel. The Emergency stop button will stop all functions and cut power to all drives of the machine. However, the computer control will continue to have power.

Wait at least 1 ½ minutes before releasing the Emergency Stop button, the drives need this time to power down and reset. If you do not wait a sufficient amount of time the drive will go into fault and they will not operate. To release the Emergency stop button turn it clockwise and it will pop back out.

Centering Knob:

The Centering knob is located at the top of the Spindle belt housing and extends the centering fingers when turned clockwise. Be careful not to over-extend the fingers when the Spindle is not in a bore or they will come completely out of the pinion drive.

CAUTION: *The Spindle drive motor must be stopped when centering. Spindle rotation engagement could severely damage the operator's hands and/or cutterhead parts.*

REFFSM4-082198

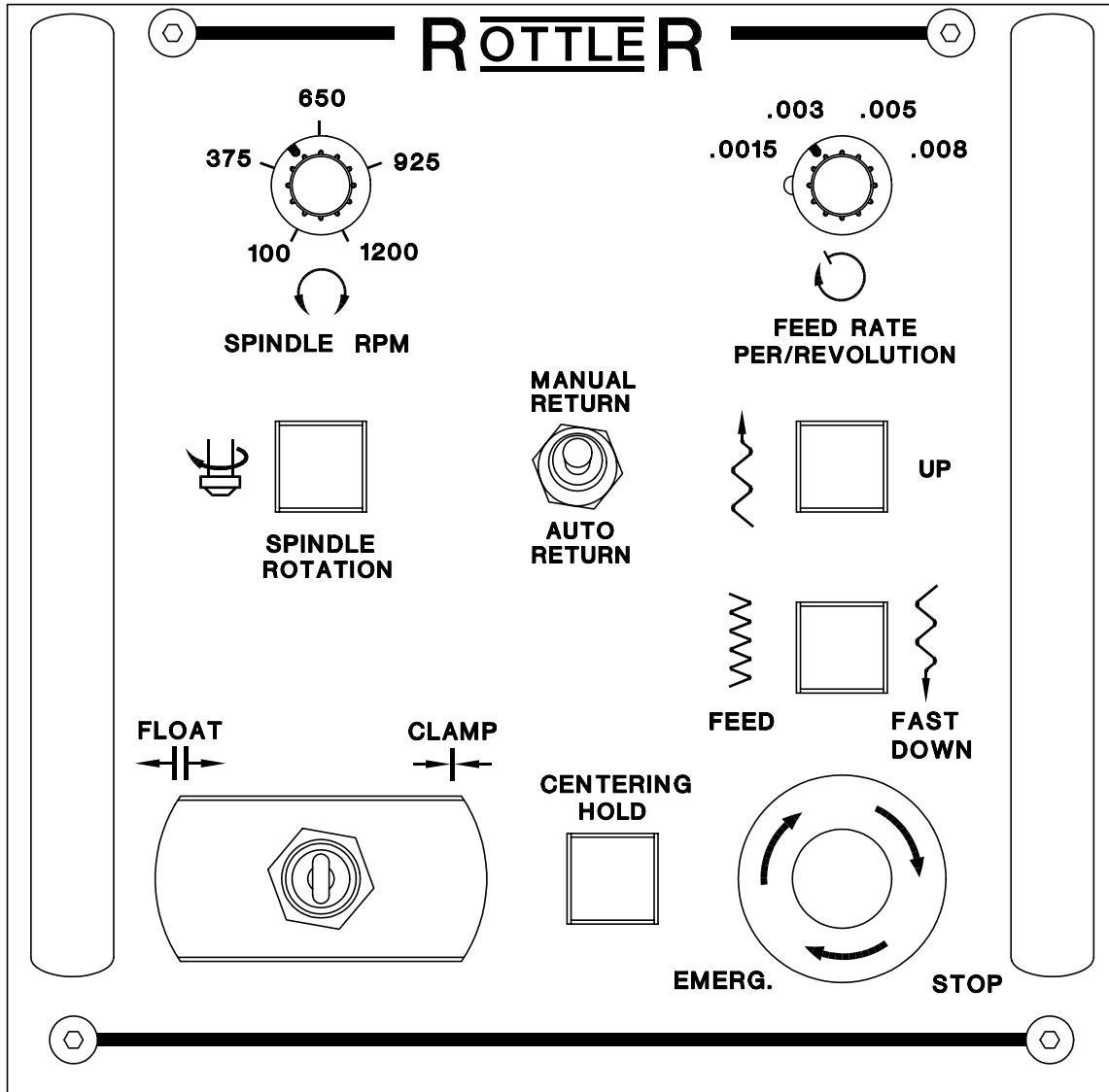

REFFSM15-12192001

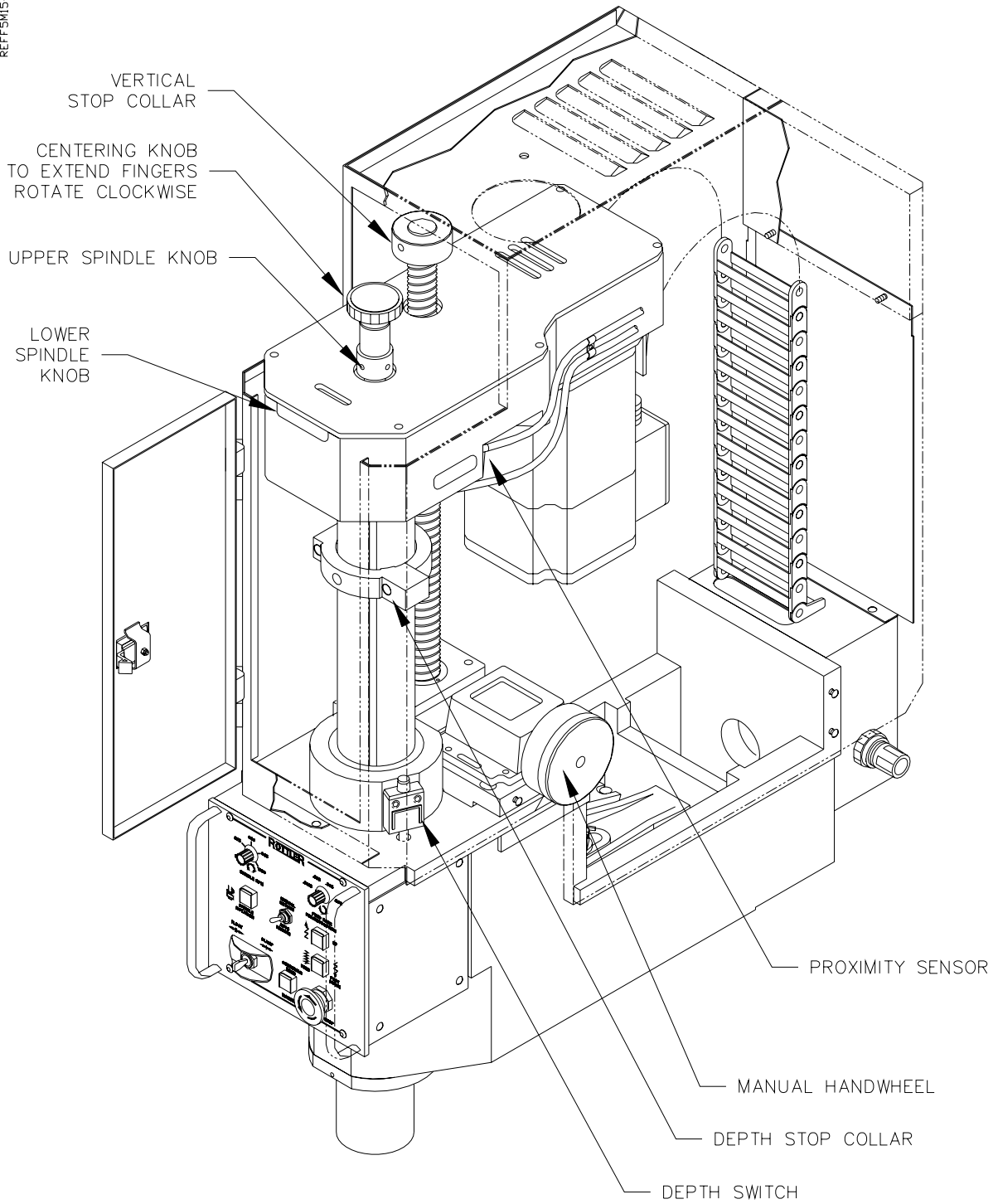

Operating Instructions:

We recommend, particularly for operators unfamiliar with boring bar, to practice on a junk block in order to become familiar with the controls and procedures of the F8M-F7M boring machine.

Loading In-Line Cylinder Blocks:

Place an inline block in the machine on top of the 5 parallel fixture. Apply weight to the top of the block at each end to be sure the block is supported evenly and does not rock. Dirt or burrs under the pan rails will result in the block not being clamped properly to all four points of the pan rails. (Please note it is necessary to properly debur and clean pan rails at support points, as opposed to cleaning the top of the cylinder block for a portable bar). You will find that some blocks will rock on the parallel fixture and should be shimmed at proper front support to eliminate this problem.

Locate the block on the parallels so that the cylinders are within the 1-3/4" (in-out travel) centering range of the spindle.

CAUTION: *Blocks can be positioned, forcing the spindle base to its travel limits, causing the spindle not to center. This will cause a mechanical crash.*

Block Clamps:

Position clamp arms so the front of the shoe will contact the block on the ends approximately in the middle.

Tighten clamp arm handles. Lower the shoe onto the block with the cam handle straight up. Tighten clamp leg handles. Lower the cam handle, to clamp the block. If the block is exceptionally long, such as in-line 8 cylinders operate the two cam handles simultaneously so that locking the first handle does not tend to tilt up the opposite side of the block.

The parallel fixture is designed with an L shape. The purpose of this is to extend the back portion of the L outward to prevent cylinder blocks from tilting up when the first clamp is applied.

Micrometer:

Note: *This micrometer is .050 to a revolution rather than .025 as on a conventional micrometer.*

Determine the cylinder bore size you wish to cut.

Choose a tool holder that will require a minimum tool bit overhang. (We recommend a maximum tool bit overhang of 5/8 outside of tool holder.)

Before setting, make sure the tool bit is indexed to a sharp cutting edge or is properly sharpened.

Your boring bar micrometer, as with any other measuring tool, should be used delicately and with care, to be assured of great and continued accuracy. Inserting the tool into the micrometer is very important. Do not let the tool bit snap against the anvil. This will cause nicks in the anvil, and will reduce the accuracy of the micrometer.

Place the tool bit and tool holder into the micrometer. Loosen the tool bit lock screw. Set the micrometer head to the desired bore size. Lightly tighten the tool bit lock screw. Back off micrometer head. Firmly tighten tool bit lock screw. Recheck micrometer reading.

After a period of use the tool bit will force a depression in the micrometer anvil. This will result in inconsistent sizes, particularly after re-sharpening the bit. As necessary turn the anvil slightly, so that a flat surface is always exposed to the tip.

Centering:

Insert the tool holder into the cutter head and push back to the index point. Tighten the tool lock screw with the plastic handled hex driver provided in your toolbox.

Activate the spindle base Float switch. Move the spindle base to the first hole of the engine block. Press the Down Rapid Travel button and hold it until the cutter head is in centering position, (be very careful not to crash the toolbit into the block).

The proper centering position is with the centering fingers approximately 1/4 inch below the surface of the block.

CAUTION: *Do not center cutterhead with motor running.*

With the Float switch still activated, press and hold the centering hold button on the faceplate, reach to the top of the spindle belt housing and turn the Centering Knob clockwise (looking from the top). The centering fingers will extend to the sides of the bore. Hold firm pressure and switch the Float switch to Neutral, pause for a couple of seconds then Clamp.

Retract centering fingers, press and hold the centering hold button, turn Centering Knob counter clockwise (looking from the top).

Centering Fingers - Remove & Replace:

CAUTION: *All motors must be turned off during any centering finger operation.*

Centering fingers can be removed by rotating the centering knob clockwise until the fingers can be pulled out. When they are replaced in the cutter head, they should be placed in the respective numbered slots. First rotate centering knob clockwise and then counter-clockwise to insure that fingers enter pinion teeth simultaneously.

Centering Accuracy Check:

Centering fingers should be kept accurate, to center the new bore within .002 of the center of the worn hole. Centering fingers should be lapped periodically to obtain near perfect centering.

Make sure the Auto Return/Manual Return switch is in the manual position. Check the centering fingers by boring a hole and then without moving the spindle unit, extend the fingers against the wall, checking to see that each fingertip will lock a .001 shim. If the fingers will not do this, they should be lapped. Rotate them back and forth in the test bore while pressing the fingers against the wall. If this does not quickly bring contact and pressure to all the fingers, carefully file the high finger or fingers, and repeat the lapping process.

Boring:**Manual Handwheel:**

Center the cutterhead as described previously. Move the cutterhead close to the workpiece (within 1 inch). Press the Spindle Rotation button. The cutterhead should start to rotate at the speed indicated by the Spindle RPM knob.

Rotate the Manual Handwheel clockwise to feed the spindle down and make the cut. Turn the handle counter-clockwise to raise from the cut

Manual Retract:

Center the cutterhead as described previously. Put the switch in the Manual Retract position. Press the Spindle Rotation button, the cutterhead will start rotating. Press the Down button, the spindle will start feeding down into the bore. The RPM of the machine can be changed at any time in the bore, the feed will automatically compensate.

After boring through the cylinder set the Stop Collar so that it actuates the Depth switch. The Stop Collar is set so that the machine will stop at the same depth in the remaining bores. If the block style changes the Stop Collar setting will also have to be changed. Watch for obstructions at the bottom of the bores. Be sure the machine will stop before hitting anything.

The spindle rotation can be stopped at any time during the bore by pressing the Spindle Rotation button again. Stopping the spindle will also stop the down feed. The down feed can also be stopped at any time by pressing the Down button again, however, the spindle rotation will not be stopped. You can continue the down feed at any time by pressing the Down button again. To stop the spindle rotation the Spindle Rotation button will have to be pressed again.

When the Depth Switch is actuated by the Stop Collar the Spindle and down feed is stopped. Press the Up button to return to the Vertical Home position.

Auto Retract:

The Auto Retract works the same as Manual Retract with this exception.

When the Depth Switch is actuated, the spindle will perform a 2-second washout of the bore, slow its rotation to the creep speed and index the cutting tool to the 3 O clock position. At the 3 O clock position the Proximity sensor is activated and the computer control activated the spindle tilt and power drive the machine to its Vertical Home position.

Boring Large Truck Blocks:

The F8M-F7M boring machine has the capacity to bore truck engines such as the in-line Mack and the in-line GMC series 71. It is necessary when boring these large blocks to remove the wear pads (502-1-21) and place the block directly on the main base (502-1-20). The blocks are then bored according to the instructions.

Optional Capacity To 8" Diameter:

For setting F8M-F7M micrometer to high and low scale using micrometer with a 2.90 to 6.00 inch reading.

CAUTION: *The standard for your F8M-F7M micrometer is not set at the factory. It must be set with a micrometer by adjusting the lock screw. Set the micrometer to the machine as described on page 3.6.*

NOTE: Read directly on the micrometer sleeve.

To set the standard, set the micrometer to 6.00 Place the standard in the micrometer with the adjusting screw towards the anvil. Loosen the adjusting screw until the pin contacts the anvil. Lightly tighten the adjusting screw. Back off the micrometer and remove the standard. Finish tightening the adjusting screw. Recheck and adjust as necessary.

To bore from 2.90 to 6.00 place standard in the micrometer and adjust the anvil so the micrometer reads 6.00"

To bore from 4.9 to 8.0 place the standard in the micrometer and adjust the anvil so the micrometer reads 4.0. The micrometer will read 2.9 to 6.0 but will actually set tool from 4.9 to 8.0 When the micrometer is set for larger bores, remember the bar will bore 2 inches larger than the micrometer reads.

Install and Remove Toolholders:

Use the 7/32 hex driver to loosen the setscrew in the side of the cutterhead. This screw only needs to be loosened it does not need to be removed.

Use the tool puller for removing the tool holder. Obviously it is not necessary to use the tool puller on long tool holders, but you will find it very useful on short ones. Thread the puller in a few turns and gently pull.

Install and Remove Cutterheads:

CAUTION: *Turn off power to machine before changing cutterhead.*

Centering fingers must be removed before changing cutter-heads. Damage to the centering fingers could result if they are left in.

Hold cutterhead firmly in one hand. Reach on top of the Spindle belt housing and locate the cutterhead handwheel. Turn the handwheel counter clockwise while still holding the cutterhead stationary. As you continue to turn the handwheel the cutterhead will drop out of the spindle.

To install the cutterhead use the above procedure, but turn the handwheel in a clockwise direction.

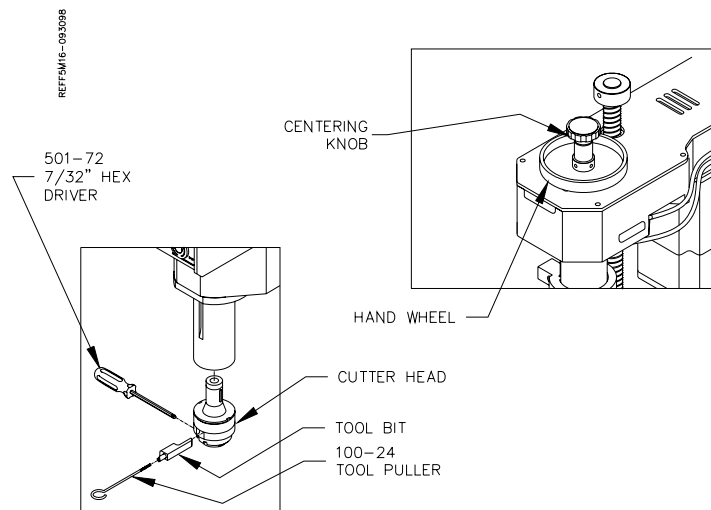

REFAYB69-120695

PROCEDURE FOR CALIBRATING MICROMETER

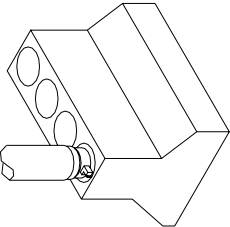
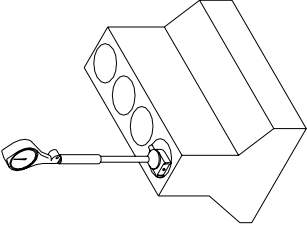
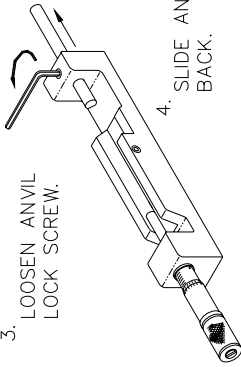
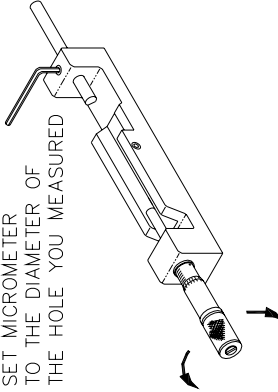
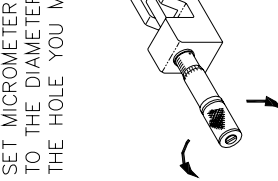
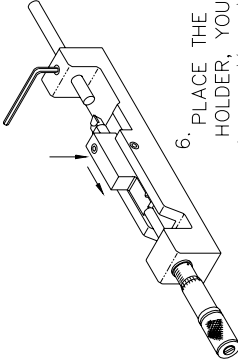
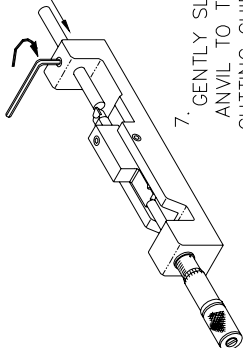
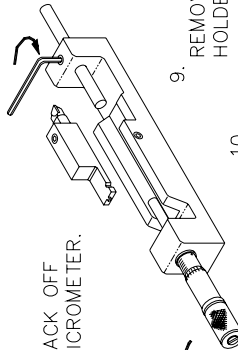
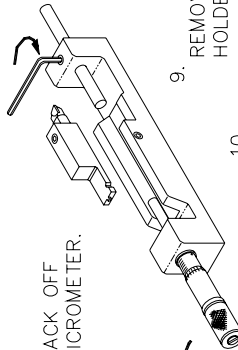
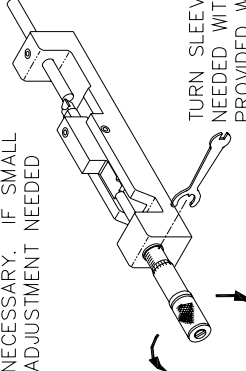
<p>1. USE THE BORING MACHINE TO BORE A HOLE IN A SCRAP BLOCK. WITHOUT CHANGING ANY SIZE SETTING REMOVE TOOL HOLDER.</p> 	<p>2. MEASURE THE HOLE THAT YOU BORED.</p> 
<p>3. LOOSEN ANVIL LOCK SCREW.</p> 	<p>4. SLIDE ANVIL BACK.</p> 
<p>5. SET MICROMETER TO THE DIAMETER OF THE HOLE YOU MEASURED.</p> 	<p>6. PLACE THE TOOL HOLDER, YOU USED, IN THE MICROMETER FRAME.</p> 
<p>7. GENTLY SLIDE ANVIL TO TOUCH CUTTING CHIP. AND LIGHTLY TIGHTEN LOCK SCREW.</p> 	<p>8. BACK OFF MICROMETER.</p> 
<p>9. REMOVE TOOL HOLDER.</p> <p>10. TIGHTEN LOCK SCREW.</p> 	<p>11. RECHECK SIZE. ADJUST IF NECESSARY. IF SMALL ADJUSTMENT NEEDED.</p> <p>TURN SLEEVE AS NEEDED WITH PROVIDED WRENCH.</p> 

Maintenance:

Lubrication:

Refer to the illustration on *page 4.5*. Below are directions, that explain where and how to add oil to the various lubrication systems.

Vertical Ballscrew:

The vertical ballscrew runs through the upper housing. Run the machine down to its lowest travel position. Open the door on the front of the machine, the ballscrew is now fully exposed.

Every 175 hours, Grease the ballscrew using ***76 Unoba EP2 Grease***, or equivalent NLGI- 2 grease. Wipe a small amount of grease on the screw just above the upper housing (with the machine at its lowest travel position).

Vertical Ballscrew Bearings:

The bearings are located at the bottom of the ballscrew inside the lower feed drive housing. Access the grease fitting on the left, outside of the spindle base.

Every 175 Hours, These bearings should be greased with, ***76 Unoba EP2 Grease***, or equivalent NLGI- 2 grease.

Outer Spindle:

The outer spindle is the chromed cylinder that travels up and down. It is supported in two bushings located in the spindle base. The outer spindle supports the inner spindle, bearings, seals, etc.. and maintains the boring rigidity.

Every 40 Hours the outer spindle surface should be cleaned with kerosene. Occasionally with ***a light weight #10 oil.*** should be wiped onto the outer spindle to prevent excessive dryness.

Inner Spindle: Oiler Setting

An air driven oil lubricator is located on the lower right of the main electrical rear enclosure. This lubricates the Inner spindle. Every time the Spindle Rotation button is pressed the oiler comes on for 60 seconds. If there is too much oil coming out of the Inner spindle turn the dial on the oiler clockwise. There should always be a slight amount of oil coming from the Inner Spindle, if there is not turn the dial counter clockwise to increase the amount of oil in the air line. Look at the top sight glass on the oiler, the oil should be set to drip at a rate of approximately 1 drop per minute.

There is air regulator located just to the left of the oiler. This should be set at 30 PSI for proper oil atomization. As mentioned above the oiler is only activated for 60 seconds every time the spindle is started. To set the oiler at one drop per minute you may have to start and stop the spindle several times.

At the beginning of each shift, check the level in the reservoir. ***Fill with a light weight #10 oil.*** Top off as necessary, There is a plug threaded into the top of the oiler for filling.

Clamp arms:

There is a grease fitting located on each clamp arm cam body.

Every 175 hours, these fittings should be greased with ***76 Unoba EP2 Grease***, or equivalent NLGI- 2 grease.

Air Adjustments:

Float:

The float regulator is located at the rear of the spindle base on the bottom of the interconnect box.

If the machine is not floating properly it could be from too much or too little air from the regulator. Turn the regulator all the way off (full counter clockwise). Start turning the regulator slowly clockwise while continually checking the spindle base for proper floatation. Once the correct float is established lock the regulator into place by pushing in on the black adjusting knob.

CAUTION: Use as little air as possible to achieve correct floatation. Using too much air will could cause the spindle base to move slightly to the right when going into tilt. This will cause a scratch up the side of the cylinder.

If you cannot get the spindle base to float properly by adjusting the regulator refer to “Not Floating” in the troubleshooting section of this manual.

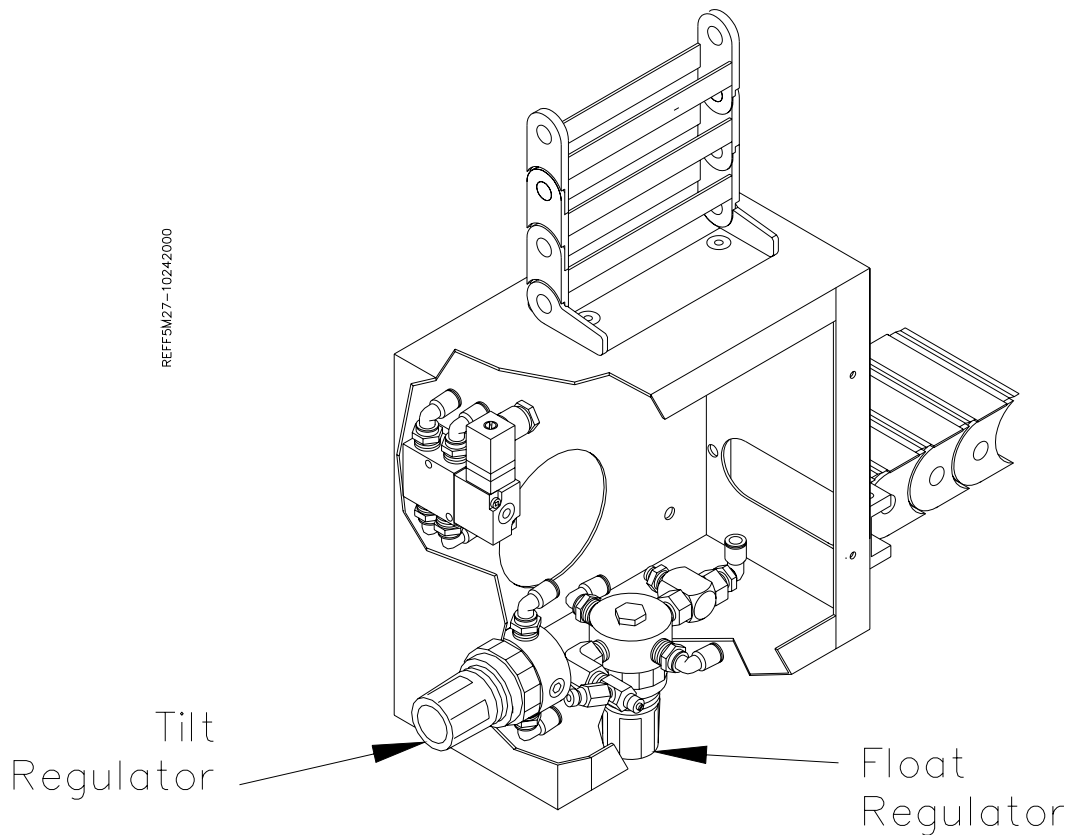

Tilt:

Locate the Tilt regulator on the right hand side of the rear interconnect box. The Tilt on the F8M-F7M is used to clear the cutting tool from the side of the cylinder when retracting from a bore. If you are not getting adequate tilt for the tool to clear the bore, an adjustment is necessary.

Place a dial indicator with a magnetic base onto the main stand next to the spindle base on the left hand side. Put the ball of the indicator on the bottom of the spindle base on the left hand side. Make sure the Auto/Manual switch is in Auto position or the spindle base will not tilt. Turn the Tilt regulator all the way off (full counterclockwise). When the Up button is pressed, the control will activate the Tilt solenoid allowing air to flow to the regulator. Slowly turn the regulator clockwise until a movement (up) of .0025" can be seen on the indicator when the Up button is pressed. Lock the adjustment into place by pushing in on the black adjusting knob.

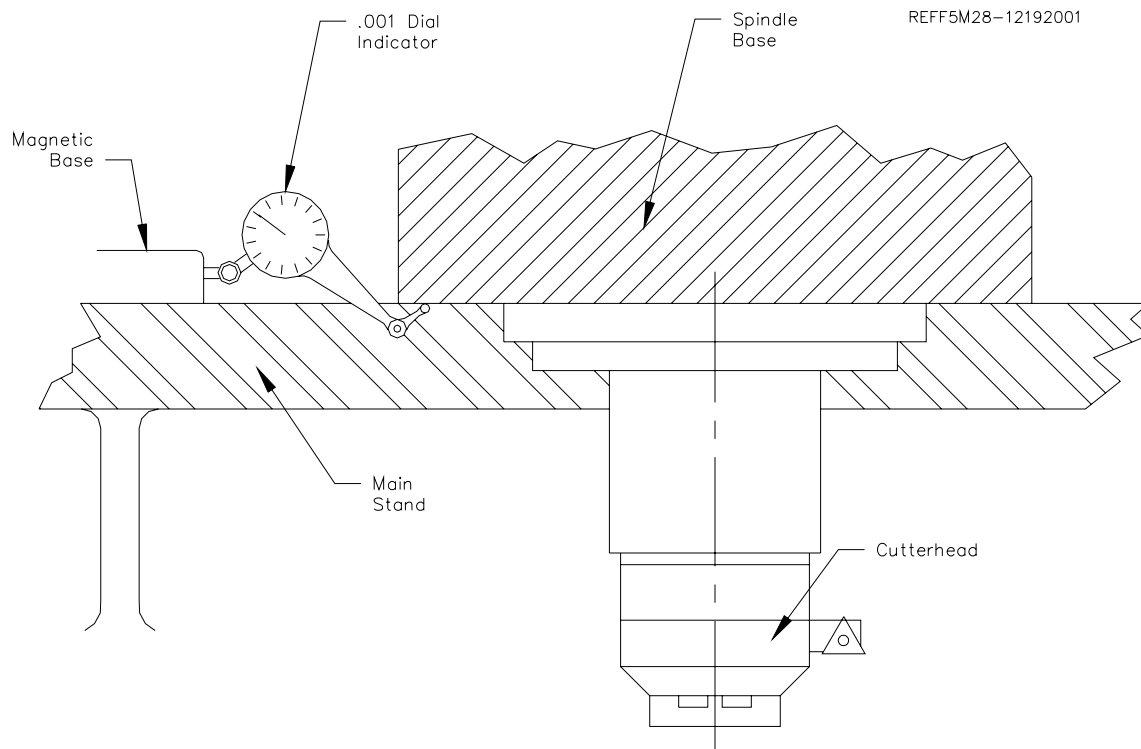

Pressure Switch:

The pressure switch is located on the main intake air manifold, located on the right hand side of the rear electronic enclosure. The pressure switch is a solid state device that opens and closes at certain air pressure settings. It should be set on the F8M-F7M to 70 PSI. If the main intake pressure goes below 70 PSI the pressure switch is designed to open and cut power form all drives. This is so the spindle base clamps do not break loose during a bore with the spindle still rotating.

Turn the main input air regulator down to 70 PSI. Remove the main air line to the machine to relieve any pressure in the system that may be over 70 PSI. Re-attach the main air to the machine. Locate the main contactor in the rear electronic enclosure (Refer to page 6.2, Illustration). This contactor has a 1 and a 0 on the front of it. 1 means the contactor is closed and the machine should be operational. 0 means the contactor is open and machine will not operate as all power is removed from drives when contactor is in this state.

If the contactor is still closed (1) at 70 PSI adjust the thimble counter clockwise until it opens (0). Then reverse direction and start rotating it clockwise until it closes. As soon as the contactor closes stop turning the thimble on the pressure switch.

If the contactor is open (0) at 70 PSI adjust the thimble clockwise until it closes (1). As soon as the contactor closes stop turning the thimble on the pressure switch.

This will set the pressure switch to drop out at 70 PSI. Return the main incoming pressure to 100 PSI.

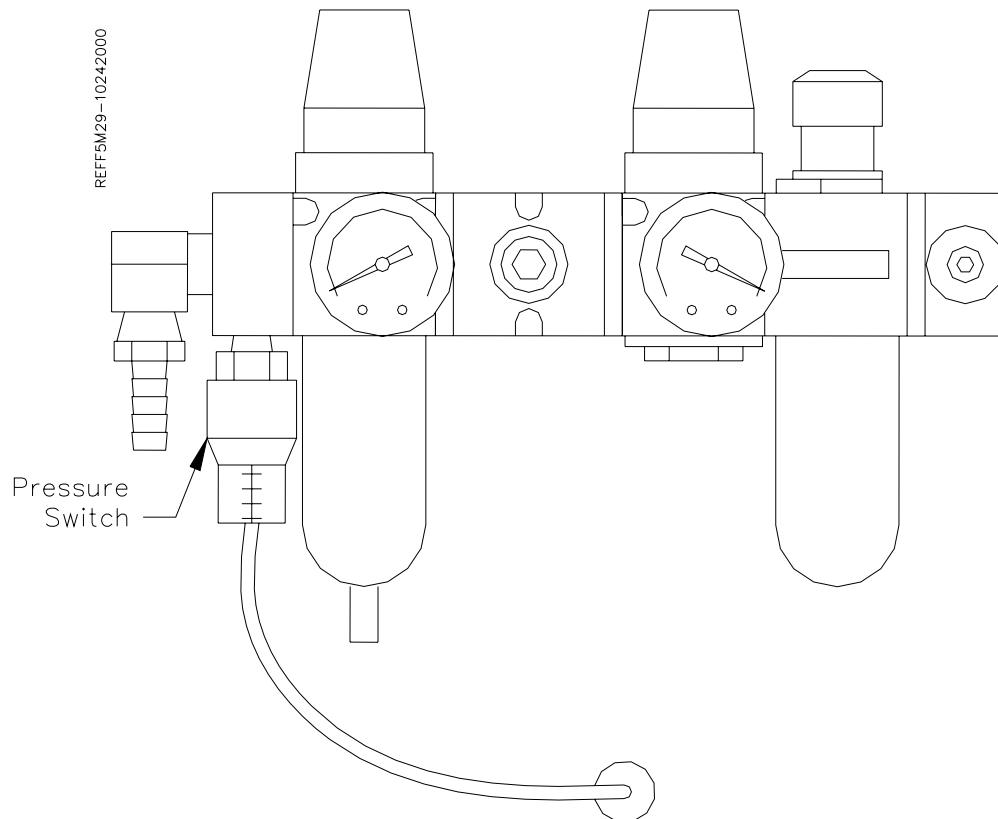

REF F8M17-0210699

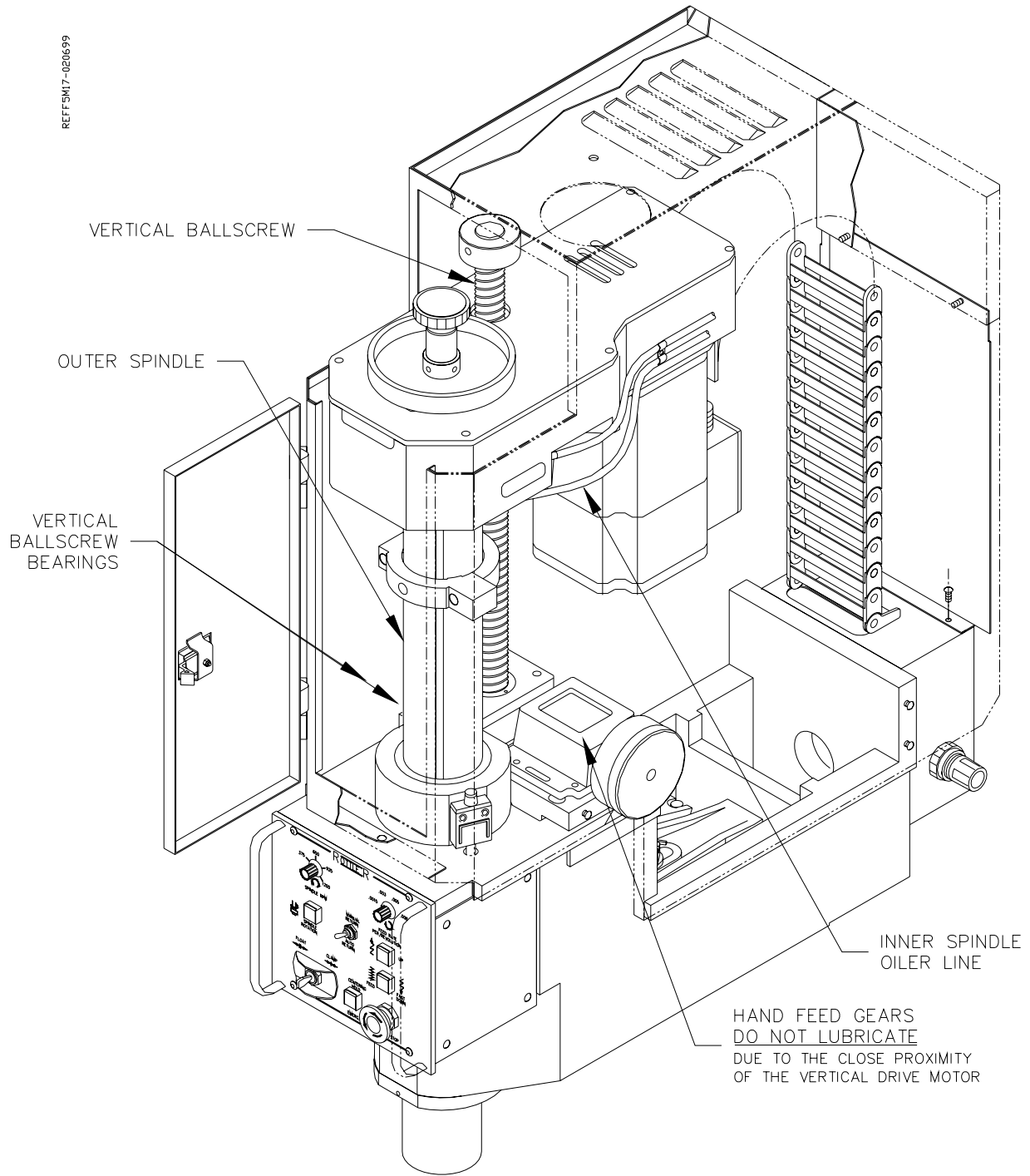

Spindle Sweep:

The spindle must be swept into the main bed for accurate boring. If you are seeing “shadowing” in the bore the spindle may need to be swept in.

Note: *If the fixturing is not square to the main bed, this may also cause “shadowing”*

Adjustment:

Remove all fixturing from the machine. Loosen the four Spindle Hub bolts and then bring them back up to a “snug” condition. If the bolts are too loose Hub will bounce when it is adjusted. The spindle Unit should be Clamped.

Attach a Mag Base to the bottom of the cutter head. Attach an indicator to the Mag Base and adjust it for a minimum of a 12” sweep diameter.

Bring the Spindle down until the indicator is touching the Main Base. You want no more than .010” pressure on the indicator. Zero the indicator. Sweep the indicator around the Main Base. If the spindle is more than .0005” off of zero on the indicator, it will need to be adjusted.

Use a Brass Drift and a Hammer to lightly tap the Spindle Hub in the direction it need to go. Once you are within .0005” all the way through the sweep area, tighten the Spindle Hub Bolts. Check the sweep area again to be sure the sweep did not move as you tightened the bolts.

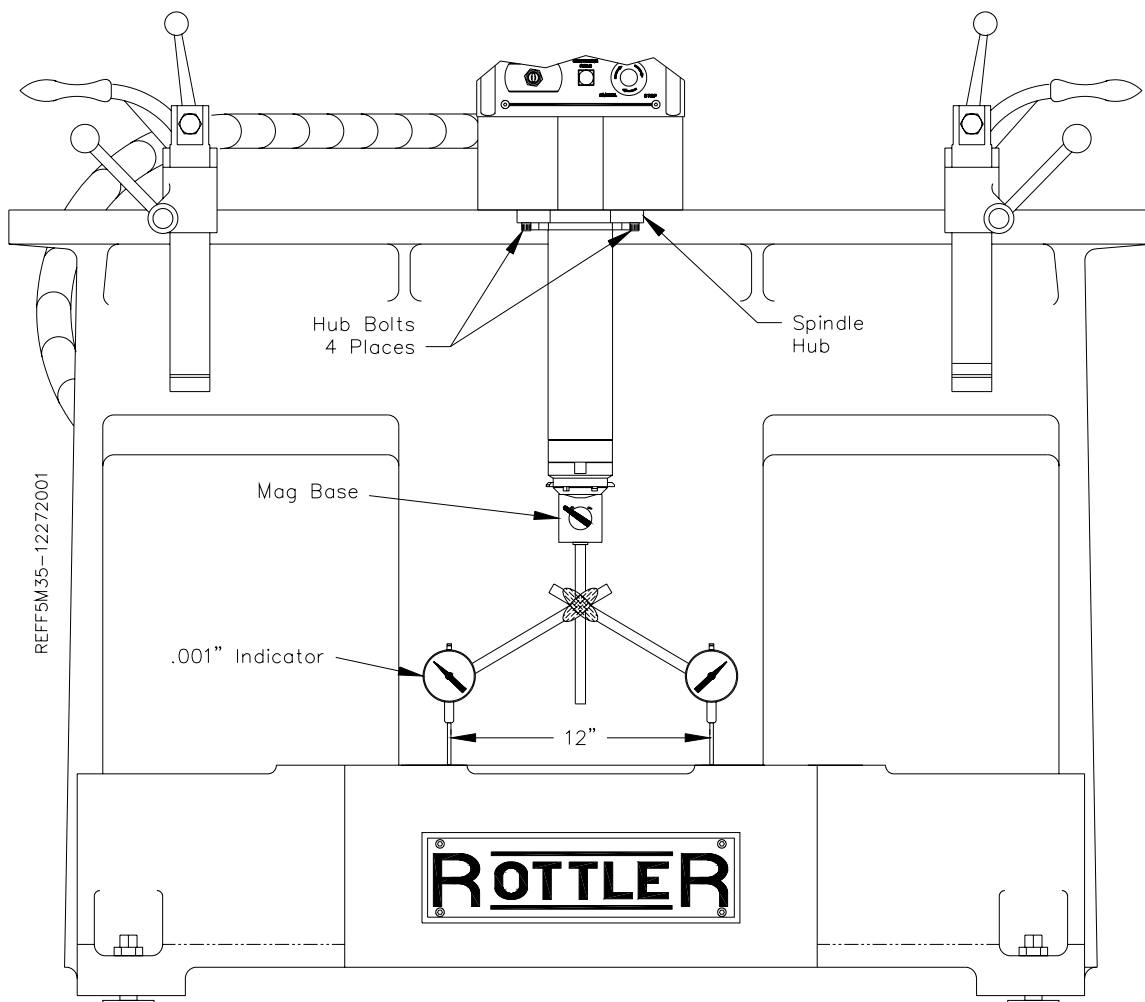

Outer Spindle Adjustment:

The main spindle bearings are tapered split cast iron rings, held in a seat by an adjustment nut. These bearings normally require no adjustment for many boring cycles.

The upper bearing is preloaded by a Belleville spring washer, located below the adjustment nut. This adjustment should be checked **after** the shipment of the machine. Shock to the machine during shipment may result in some setting of the spring.

CAUTION: *Be careful not to over tighten these bearings. An over tight condition only serves to wear out the machine and make control operation difficult.*

If it is necessary to adjust, see the following instructions:

Move the spindle base to a clear position making sure the spindle can travel its full vertical length. Thoroughly clean and lightly oil the Outer Spindle before adjustment.

Remove the upper felt retaining nut and felt wiper from the flange sleeve. Tie a rag around the outer spindle to hold them up at the top of the spindle. This will expose the upper bushing adjustment nut. Remove the lower wiper retainer ring along with the wipers and felts to expose the lower spindle bushing adjustment nut.

Loosen the set screws located on the front of the upper and lower portion of the Spindle Base. Loosen the upper and lower bushing adjustment nuts to remove any pressure on the bushings. Tighten the upper and lower adjustment nuts evenly until they are lightly touching, but have no load on them.

Move the spindle down to pull the Upper Bushing into the upper hub. Using a punch and hand pressure only, tighten the Upper adjustment nut until it bottoms out on the Upper Bushing (calapsing Load Spring). Move the spindle up to pull the Lower bushing into the Lower Hub. Tighten the lower bushing the same as the top again only using hand pressure. If there is taper in the bore on large cuts tighten the lower bushing slightly more using a hammer.

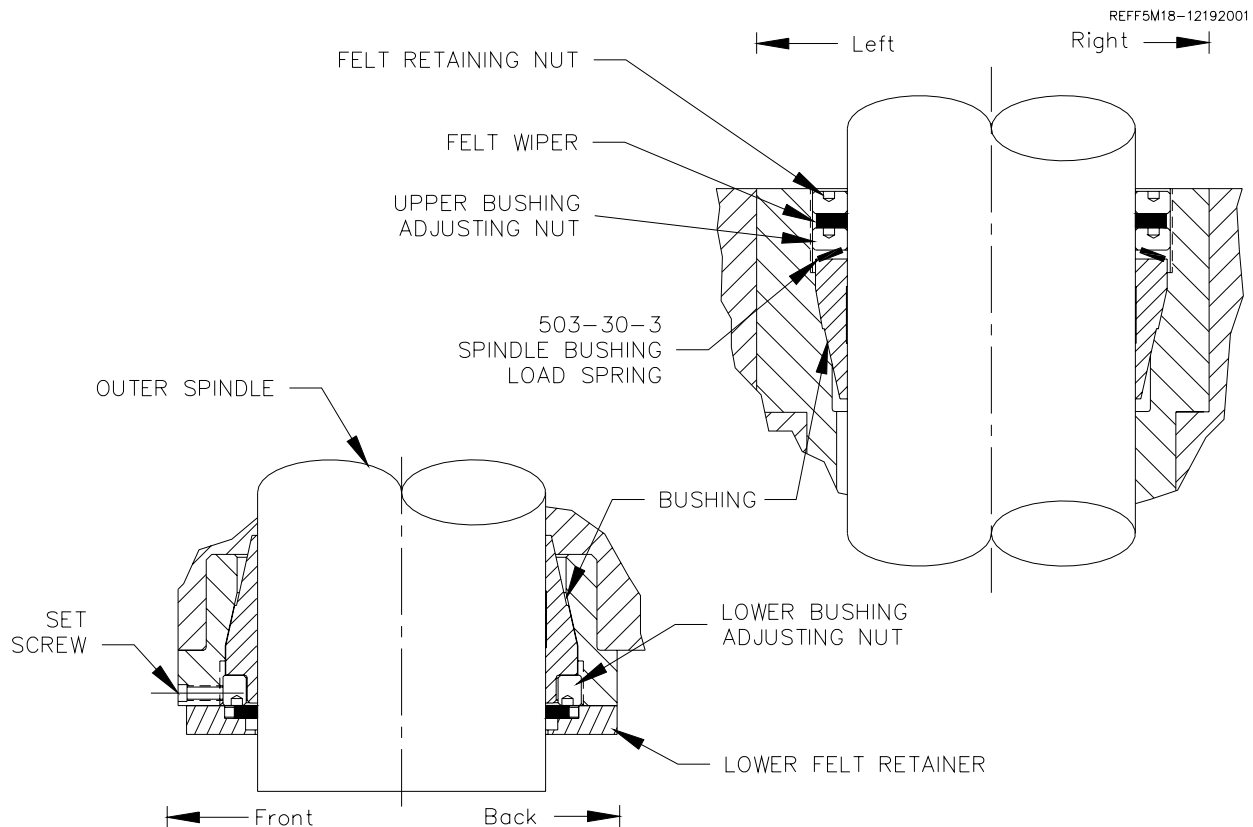

Inner Spindle Adjustment:

This machine is equipped with anti-friction bearings at the top and bottom of the Inner Spindle. It is very important to properly adjust the pre-load of these bearings. Setting these bearings either too tight or too loose can greatly reduce bearing life or destroy them all together.

Adjustment:

Insert a pin (diameter .180 or less) in one of the holes in the Outer Diameter of the Take Up Nut (this is located on top of the main spindle pulley). Secure a cutterhead (2) in the spindle, with a long tool holder (3) in place. Hold the cutterhead with your hand while turning the take up nut, to the left (clockwise). You will note the nut ratchets in notches as you take it up. Continue taking it up until the nut tightens up and then back off 1 notch. **Do not over tighten the nut, this will cause a crushing of the bearings and it will have to be replaced.**

CAUTION: Be sure the detent is in a notch, not midway between, this would cause the nut to slip backwards off adjustment.

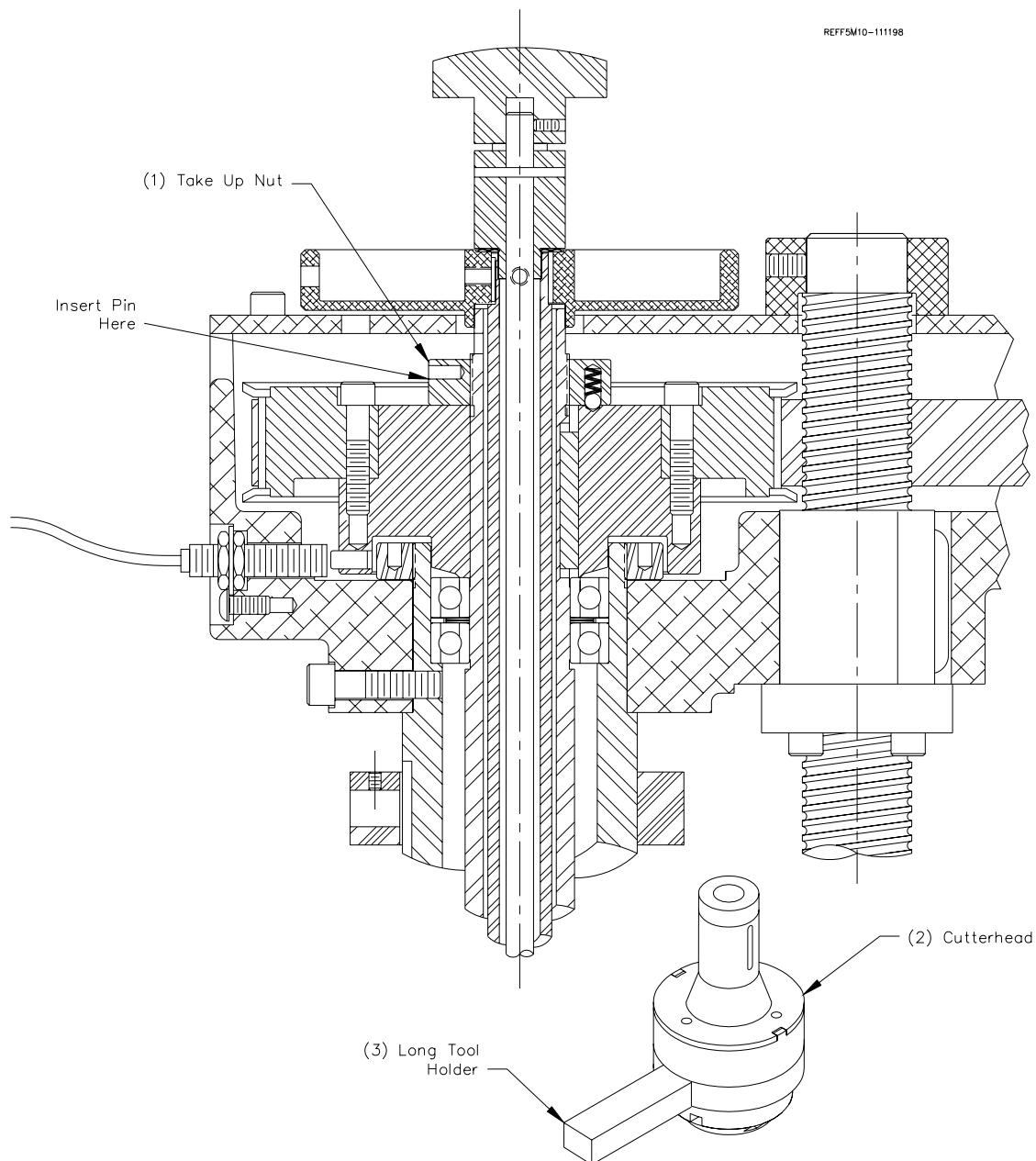

Home Sensor Adjustment

The Home sensor is located on the top of the belt Housing Cover (1). When the machine reaches the Home position the Stop Collar (2) activates the Home Sensor. If the spindle is running into the Stop Collar or will not travel the Sensor may need adjustment.

Adjustment:

Remove the shroud from the machine. Make sure the shroud is supported from the top by an overhead lifting device before removing all of the screws. Remove the four allen screws located on each side. Remove the two from the back cover. Open the front door on the shroud and remove the screw located just below the door. Lift the shroud from the machine, being careful it doesn't hang up on anything as you lift.

Move the machine to the Home position (Sensor (4) even with Stop collar). Loosen the two Locking Nuts (1) on both sides of the Sensor Mounting Bracket (2). Bring the Sensor to within .040 of the Stop Collar (3). Tighten Locking Nuts.

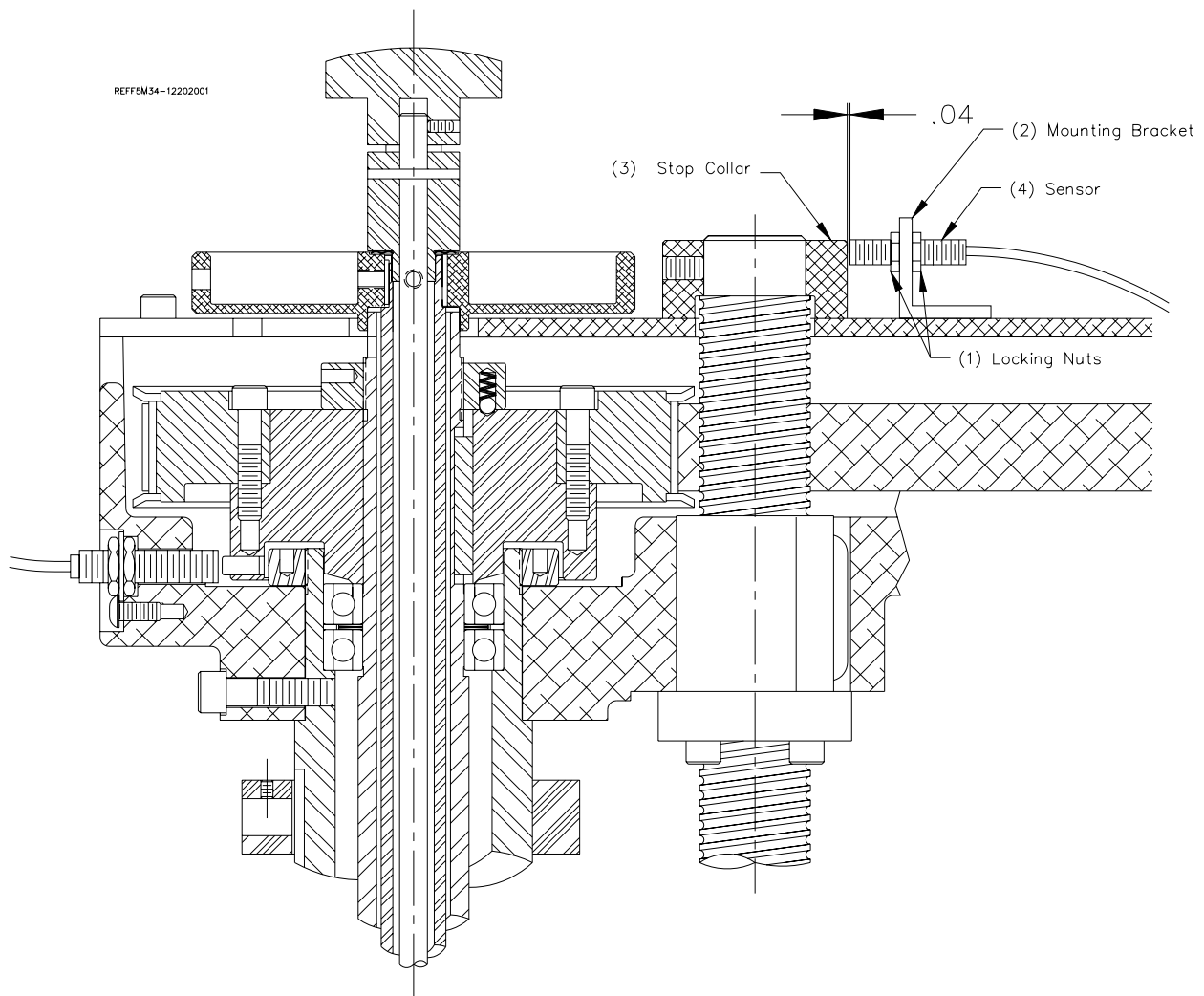

Spindle Index Sensor Adjustment:

The purpose of the Spindle Index Sensor is to stop the spindle from turning with the tool bit facing in the correct direction. In order for the machine to rapid return from the bottom of a bore without scoring the cylinder wall as it comes up, the spindle must stop with the tool facing to the operators right. If the spindle will not index properly, it may need to be adjusted.

Remove the shroud from the machine. Make sure the shroud is supported from the top by an overhead lifting device before removing all of the screws. Remove the four allen screws located on each side. Remove the two from the back cover. Open the front door on the shroud and remove the screw located just below the door. Lift the shroud from the machine, being careful it doesn't hang up on anything as you lift.

The spindle stop sensor is located on the right side of the belt housing, just to the back side of the spindle. You will see a threaded chrome piece extending from the belt housing with a gray wire attached to it. When the spindle is indexed to the 3 o'clock position a light will come on at the rear of the sensor. If the sensor light does not come on when the Spindle is in the correct index position, it may need to be adjusted.

Locate the elongated access hole on the right side of the spindle housing, looking into it you should be able to see the end of the sensor and the dowel pin extending from the spindle hub. When lined up correctly there should only be about a .040" gap between the two. To adjust this gap, remove the slotted head screw from the belt housing, holding the sensor. Loosen the two nuts on the sensor holding the washer. Adjust the position of the washer until the correct gap is reached. Lock the nuts into place and re-install into belt housing.

If the sensor light still does not come on contact the factory for assistance in trouble shooting other possible causes.

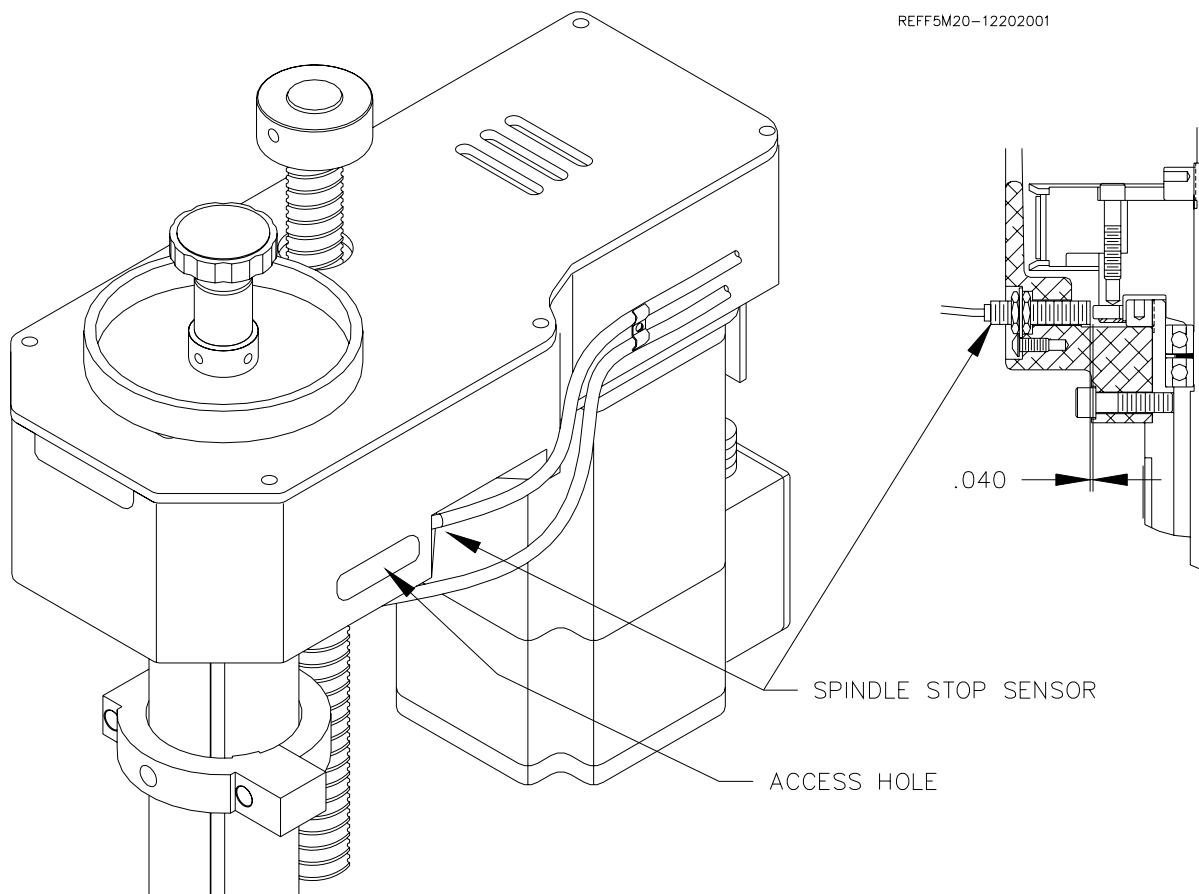

Spindle Drive Belt Removal/Replacement and Adjustment:

CAUTION: *Disconnect all power to the machine before proceeding.*

Accessing Spindle Drive Belt: (see illustrations pages 6.10 & 6.12)

Remove the shroud from the machine. Make sure the shroud is supported from the top by an overhead lifting device before removing all of the screws. Remove the four allen screws located on each side. Remove the two from the back cover. Open the front door on the shroud and remove the screw located just below the door. Lift the shroud from the machine, being careful it doesn't hang up on anything as you lift.

Remove the set screws in the mechanical stop on top of the vertical ballscrew. Remove the stop. Remove any cutterheads in the machine. Lift the centering shaft and drawbar from the machine by lifting straight up on the centering knob. Remove 5 screws holding the upper housing cover, lift the cover off the housing.

Loosen, DO NOT REMOVE, the four screws securing the spindle drive motor. Loosening the screw at the very back of the upper housing will take the tension off the belt, by allowing the motor to slide forward (some machines may require the plastic cable carrier be loosened to expose the screw head).

Removing Spindle Drive Belt:

Loosen the four screws attaching the driven pulley to its bushing. Lift the pulley and the belt straight up. ***Do not loosen the inner-spindle adjustment nut.***

Installing Spindle Drive Belt:

Place the belt around the driven pulley and slide them together down over the driven pulley bushing. Rotate the pulley until you can line up the four mounting screw holes. Install the screws, and tighten. Pull the motor to the back of the upper housing, with the motor adjusting screw, to tighten the belt.

Belt Adjustment:

Tighten the motor adjusting screw until you can deflect the belt .12 inch (3.17mm) when a pressure of 4.5 to 5 pounds (9.92kg to 11.02kg) is applied to the belt midway between the drive and driven pulleys.

Tighten the motor mount screws. Replace the upper housing cover, and tighten the mounting screws. Replace the drawbar / centering shaft assembly, by sliding it back down into the inner spindle from the top. Replace the vertical stop to the top of the ballscrew and tighten the set screws. Lower the shroud back onto the machine and fasten the mounting screws.

Excessive Loads:

Thrust Overload:

The drive that controls the vertical motor on the F5 series machines, will trip out when a vertical stall occurs. This is a condition that happens when the machine is fed or rapid traveled into the top of a work piece. It would not make any difference if the spindle was turning or not. This can happen, by misaligning the machine with the bore, or by boring into a hole with an obstruction at the bottom. A vertical stall can also be caused by rapid traveling up into the mechanical stop at the top of the ballscrew.

The first step in correcting a vertical overload condition is to determine what happened to cause it. You will probably have to move the spindle off the obstruction manually, because the machine will tend to physically jam in position and the motor once reset will not be able to move.

Once the jam is cleared press the E-stop button on the face of the machine, wait for at least 1 ½” Minutes. Turn the E-stop button to release it. The machine will reset itself, and be ready to run again.

Be sure you have determined the cause of the crash before continuing.

Spindle Overload:

If the spindle is turning, as in boring or counter-boring, and the tool bit hits an obstruction, the drive that controls the spindle motor will trip out. This can happen if there is an unseen web at the bottom of a bore, or if the machine is extremely off center when a cut is started.

The first step in correcting a spindle overload condition is to determine what happened to cause it. You will probably have to move the spindle off the obstruction manually, because the machine will tend to physically jam in position and the motor once reset will not be able to move.

Once the jam is cleared press the E-stop button on the face of the machine, wait for at least 60 seconds. Turn the E-stop button to release it. The machine will reset itself, and be ready to run again.

Be sure you have determined the cause of the crash before continuing.

Vertical Drive Housing:

CAUTION: *Disconnect all power to the machine before working on the Vertical Drive Housing.*

All work being done to the vertical drive housing, such as replacing or adjusting the belt, replacing the motor, or the ballscrew bearings, requires the housing be removed from the spindle base. Following are details for working on the housing.

Accessing Vertical Drive Housing and Mechanical Hand Feed Housing:

Remove the shroud from the machine. Make sure the shroud is supported from the top by an overhead lifting device before removing all of the screws. Remove the four allen screws located on each side. Remove the two from the back cover. Open the front door on the shroud and remove the screw located just below the door. Lift the shroud from the machine, being careful it doesn't hang up on anything as you lift.

Mechanical Hand Feed Gear Housing:

Remove the hand feed wheel and housing, to expose the mounting bolts for the vertical drive housing. There are two screws securing the hand feed housing. Remove the screws and lift the housing off. When replacing the hand feed gear housing, set it back on, over the gear mounted to the vertical drive motor, and put in the two screws.

Adjusting Mechanical Hand Feed Gear Housing: (early machine)

If you have disassembled the hand feed housing, you need to adjust it for the smoothest operation. Loosen the mounting screws for the hand feed gear housing. The housing is resting on four set-screws so it can be adjusted up and down. The mounting screw holes are slotted so the housing can be moved in and out. You should not need to adjust the factory set height. Slide the housing toward the ballscrew until the gear teeth touch. Be sure to keep the housing straight with regards to the edge of the vertical drive housing. Pull the housing back away until the handwheel can be rotated approximately .06 inch (1.52mm) without moving the mating gear. This is the backlash between the gear teeth. Tighten the mounting screws and rapid travel the machine up and down to check the operation. If the gears are too noisy then readjust increasing or decreasing the backlash until they run smooth.

It may be necessary to raise or lower the housing in order to get the gears running smoothly. Be very careful to keep the housing level, adjusting all four set screws evenly. Make sure the gears mesh fully without being tight.

Removing Vertical Drive Housing:

Remove the Mechanical Hand Feed Gear Housing, as described above.

Remove the four mounting screws located at the left and right sides of the housing. Place an engine block or something under the end of the outer spindle to support its weight. Remove the electrical connections on the vertical drive motor. The two cables unscrew at the motor connection box. Manually, turn the ballscrew counter-clockwise to raise the housing up out of the spindle base.

Replacing Vertical Drive Belt:

With the Vertical Drive Housing lifted, loosen, **do not remove**, four screws securing the motor mount. Remove the screw and the bevel gear from the top of the motor shaft. Locate two, belt tension adjusting set screws on the side of the motor mount plate. Back off the set screws until the motor will slide all the way toward the ballscrew. Remove the motor, mount plate, and belt from the vertical drive housing. Place a new belt around the driven pulley, raise the motor and drive pulley into place. Adjust as described below.

Adjusting Vertical Drive Belt:

If you installed a new belt, or if you disassembled the drive housing for another reason you need to adjust the belt. The vertical drive housing must be up out of the spindle base, and the motor mount plate screws in, but not tight. Make sure the drive pulley (attached to the motor) and the driven pulley (attached to the ballscrew) are lined up so the belt runs level. Screw in the belt tension adjusting set screws until the belt

can be deflected .12" (3.17 mm) when 3 to 4 lbs.(6.61 to 8.82kg) pressure is applied midway between the drive and driven pulleys. Tighten the motor mount plate screws.

Replacing Vertical Drive Housing:

Be sure the belt is adjusted properly and the motor mount plate is tightened down securely. Manually, turn the ballscrew clockwise to lower the vertical drive housing back into position. Put in the screws to secure the vertical drive housing but don't tighten them yet. Hook up the cables to the vertical drive motor. Turn on the machine and run the spindle all the way to the bottom. Loosen up the vertical drive housing mounting screws, and then tighten them fully. This ensures the ballscrew is lined up properly.

Place the bevel gear on the end of the motor shaft. Be sure the drive pin is lined up properly, and tighten the mounting screw. See *page 4.8* for mounting the mechanical hand feed gear housing.

Inner Spindle Removal:

Raise the spindle all the way to the top of its travel. Move the spindle base to the extreme left of its travel.

CAUTION: *Disconnect all power to the machine before removing the inner spindle.*

Remove the drive belt as described on *page 4.6*.

Be sure to support the inner spindle with a block of wood or something to keep it from falling out. (see *page 6.10*) Loosen the upper nut, remove it and the index bushing from the inner spindle. The inner spindle can now be lowered out of the outer spindle. The lower tapered bearing should come out with the inner spindle, its outer race will stay inside the outer spindle. The upper ball bearings will stay inside the upper housing.

Clean the bearings and re-install or install new bearings, on the inner spindle. Lubricate the bearings with several drops of oil prior to installing (see *page 4.1 Inner Spindle section for recommended oil*). Slide the spindle up in the outer spindle. Place a block or something under the inner spindle to hold it in place. Replace the upper bearings and Belleville springs. Be sure the springs are inserted correctly as shown on *page 6.10*. Place the index bushing on the inner spindle and thread on the upper spindle nut. (see *page 4.4 for inner spindle adjustment procedure*) (Refer to *page 4.6 for re-assembly and belt adjusting procedure*)

Upper Housing Removal:

Remove the inner spindle as described above. Disconnect the motor cables from the connection box on the rear of the spindle motor. Remove the spindle stop sensor from the right side of the upper housing. Disconnect the oiler line from the fitting located on the right side of the upper housing by pushing in on the outer ring of the fitting then pull the line free. Disconnect the electrical conduit mounting bracket at the rear of the upper housing. Place some sort of block under the outer spindle to keep it from falling. Remove the outer spindle nut from inside the upper housing. (see *page 6.10*) Remove the three bolts from the outside of the upper housing that bolt it to the outer spindle. Remove the four screws securing the ballscrew nut to the upper housing. The upper housing should now be free to lift off the outer spindle.

Outer Spindle Removal:

Remove the upper housing as described above. Refer to the directions on *page 4.3*, and loosen the upper and lower bushing adjusting nuts all the way. The outer spindle should lift out of the spindle base.

Fault	Possible Cause	Possible Solution
Spindle light blinking	<p>Spindle drive trip.</p> <p>E-stop is in.</p> <p>Spindle breakers have been tripped.</p> <p>Air pressure sensor is activated.</p>	<p>Read error on spindle drive keypad and consult trouble shooting section of the drive manual for corrective action. Consult factory for assistance if needed.</p> <p>Release e-stop.</p> <p>Reset breakers. If breaker trips again measure incoming voltage and contact factory for assistance if needed.</p> <p>Reset the air pressure sensor by using instructions in this manual.</p>
Vertical light blinking	<p>Vertical drive trip.</p> <p>E-stop is in.</p> <p>Vertical breakers have been tripped.</p> <p>Air pressure sensor is activated.</p>	<p>Read error on vertical drive keypad and consult trouble shooting section of the drive manual for corrective action. Consult factory for assistance if needed.</p> <p>Release e-stop.</p> <p>Reset breakers. If breaker trips again measure incoming voltage and contact factory for assistance if needed.</p> <p>Reset the air pressure sensor by using instructions in this manual.</p>
No Spindle Rotation	<p>Spindle drive has tripped.</p> <p>Spindle drive is in Local mode.</p> <p>PLC not giving outputs with verified inputs.</p> <p>Resolver not aligned.</p> <p>Spindle drive bad.</p>	<p>Read error on spindle drive keypad and consult trouble shooting section of the drive manual for corrective action. Consult factory for assistance if needed.</p> <p>Press the LOCAL button on the keypad and the drive will go to REMOTE operation mode.</p> <p>PLC not seeing input.</p> <p>If PLC is getting a input replace PLC.</p> <p>Refer to the drive operating manual supplied with machine and re-align resolver.</p> <p>Replace Spindle drive.</p>

<p>No Spindle Rotation Cont.</p>	<p>Bad connection or power cable.</p> <p>Bad motor.</p> <p>Mechanical bind.</p> <p>Motor not tuned into drive</p>	<p>Check continuity of cable and replace if needed.</p> <p>Replace motor.</p> <p>Turn power off to machine and verify free movement of spindle drive system.</p> <p>Refer to drive operating manual supplied with machine and tune motor in. Contact factory for assistance.</p>
<p>No Vertical Movement</p>	<p>Vertical drive has tripped.</p> <p>Vertical drive is in Local mode.</p> <p>PLC not seeing input.</p> <p>PLC not giving outputs with verified inputs.</p> <p>Resolver not aligned.</p>	<p>Read error on vertical drive keypad and consult trouble shooting section of the drive manual for corrective action. Consult factory for assistance if needed.</p> <p>Press the LOCAL button on the keypad and the drive will go to REMOTE operation mode.</p> <p>Vertical start button could be bad. Check button and replace if needed.</p> <p>Wires on back of vertical start button could be loose. Check wires on button.</p> <p>Input wire to PLC could be loose. Check connection. Input on PLC could be bad. Contact factory for assistance in testing input.</p> <p>PLC not running program. Contact factory for assistance.</p> <p>The connection between common and ground has been broken. Check all com and ground wires for security it their terminals. Test for continuity between the terminals using a Ohm meter. Contact factory for assistance if needed.</p> <p>If PLC is getting a input replace PLC.</p> <p>Refer to the drive operating manual supplied with machine and re-align resolver.</p>

<p>No Vertical Movement cont.</p>	<p>Vertical drive bad. Bad connection or power cable. Bad motor. Mechanical bind. Motor not tuned into drive</p>	<p>Replace Vertical drive. Check continuity of cable and replace if needed. Replace motor. Turn power off to machine and verify free movement of vertical drive system. Refer to drive operating manual supplied with machine and tune motor in. Contact factory for assistance.</p>
<p>No tilt</p>	<p>Machine in Manual mode. Solenoid is bad. Castle nut too tight. Air settings incorrect. PLC is not outputting.</p>	<p>Put machine in Auto Mode Replace solenoid Back Castle nut off until the washer below has free movement in the neutral mode. Refer to machine manual for correct settings. Replace PLC. Contact factory for assistance.</p>
<p>Spindle Falling when power is off.</p>	<p>Outer bushings too loose.</p>	<p>Refer to operator manual for adjustment procedures.</p>
<p>Chatter in bore.</p>	<p>Inner spindle out of adjustment. Cutterhead has oil in it.</p>	<p>Refer to operator manual for adjustment procedures. Remove cutterhead from machine, disassemble and clean counter weight. Counter weight must be dry and have free movement.</p>
<p>Bore out of round.</p>	<p>Inner spindle out of adjustment Fixturing is moving.</p>	<p>Refer to operator manual for adjustment procedures. Check fixturing for security.</p>
<p>Taper in Bore</p>	<p>Outer spindle out of adjustment Dull tooling.</p>	<p>Refer to operator manual for adjustment procedures. Sharpen tool or change corners on indexable tooling.</p>

Spindle motor noisy	Drive and motor out of tune.	Refer to drive manual supplied with machine for adjustment procedures. Contact factory for assistance.
Vertical motor noisy	Handwheel out of adjustment.	Refer to operator manual for adjustment procedures.
	Drive and motor out of tune.	Refer to drive manual supplied with machine for adjustment procedures. Contact factory for assistance.

F8M Front Right Side View:

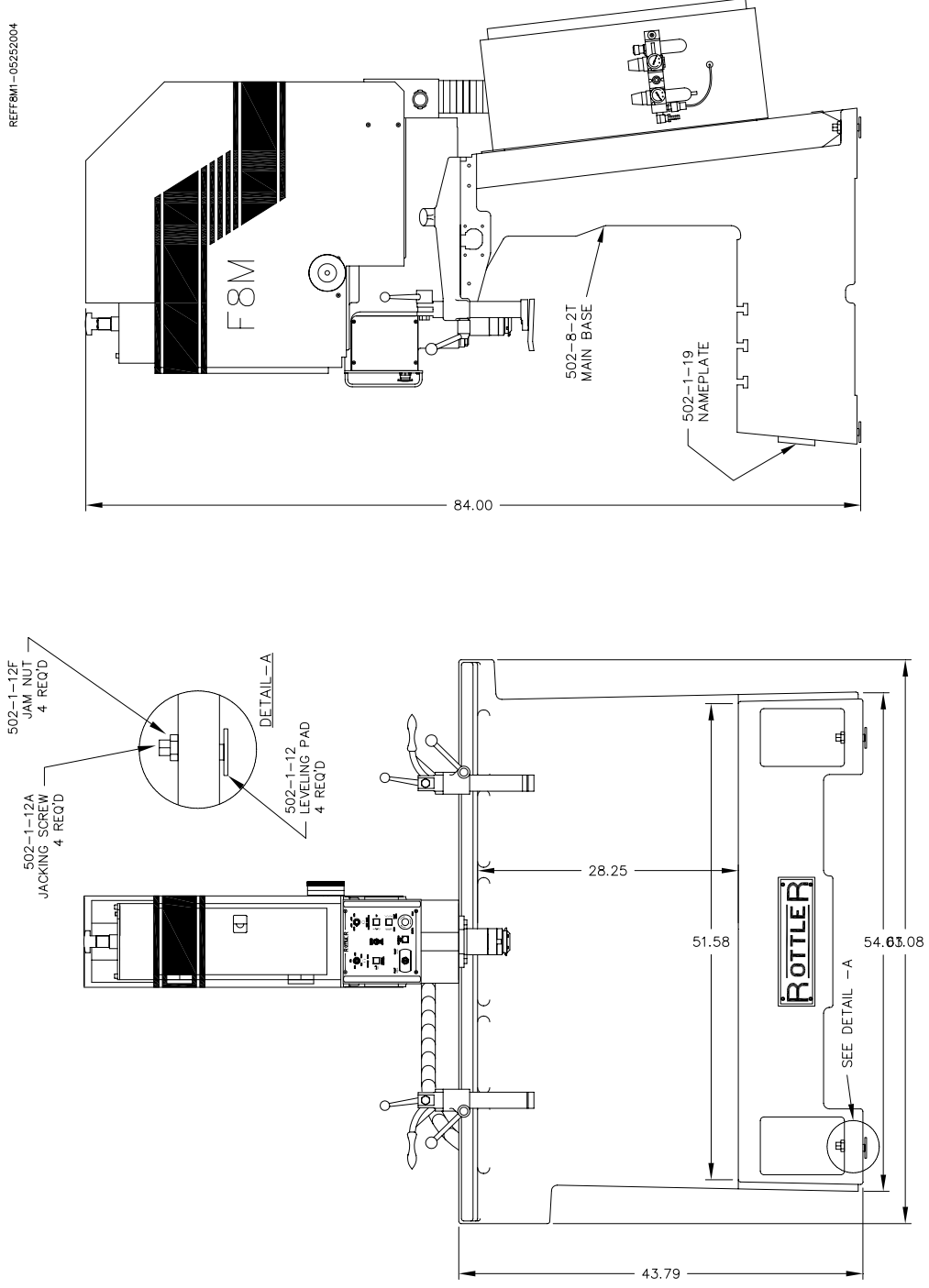

F7M Front Right Side View:

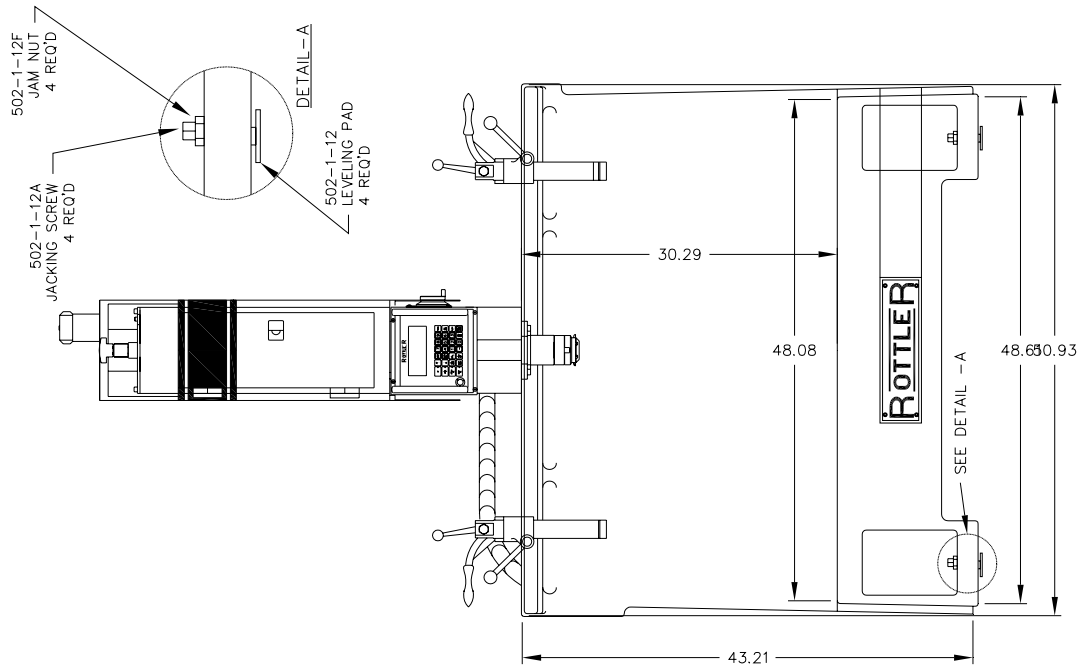
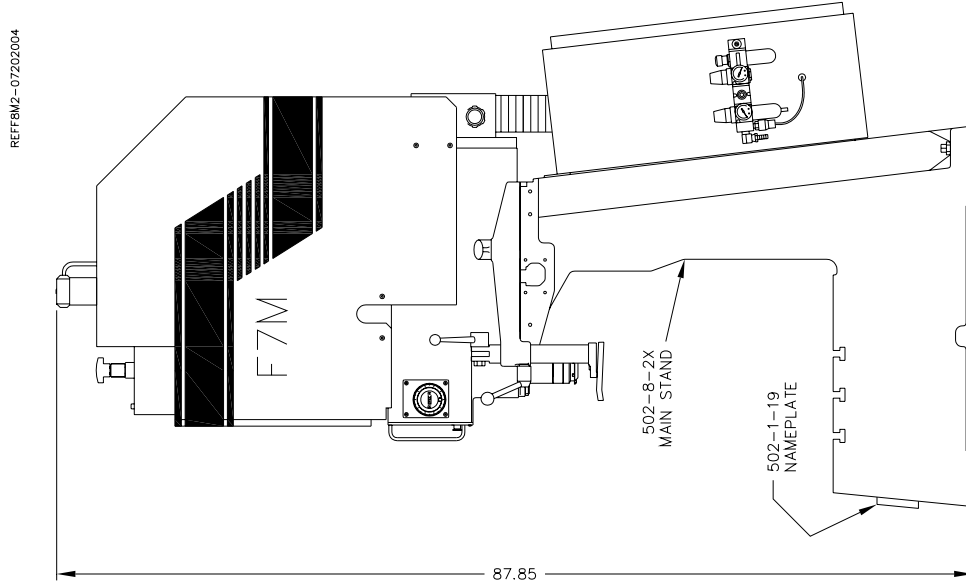

Air Logic Diagram:

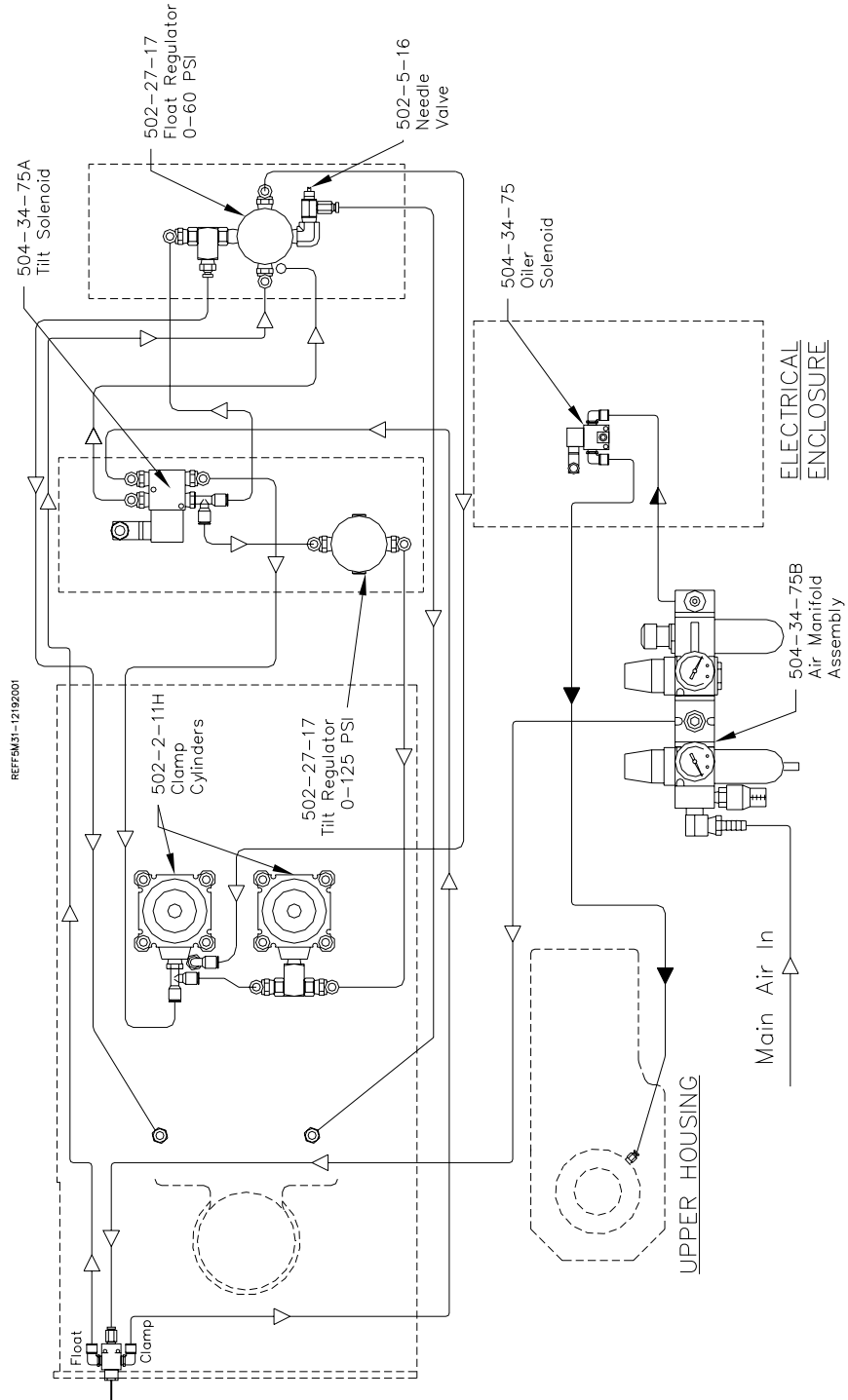

Electronic Enclosure:

REF F8M3-12202001

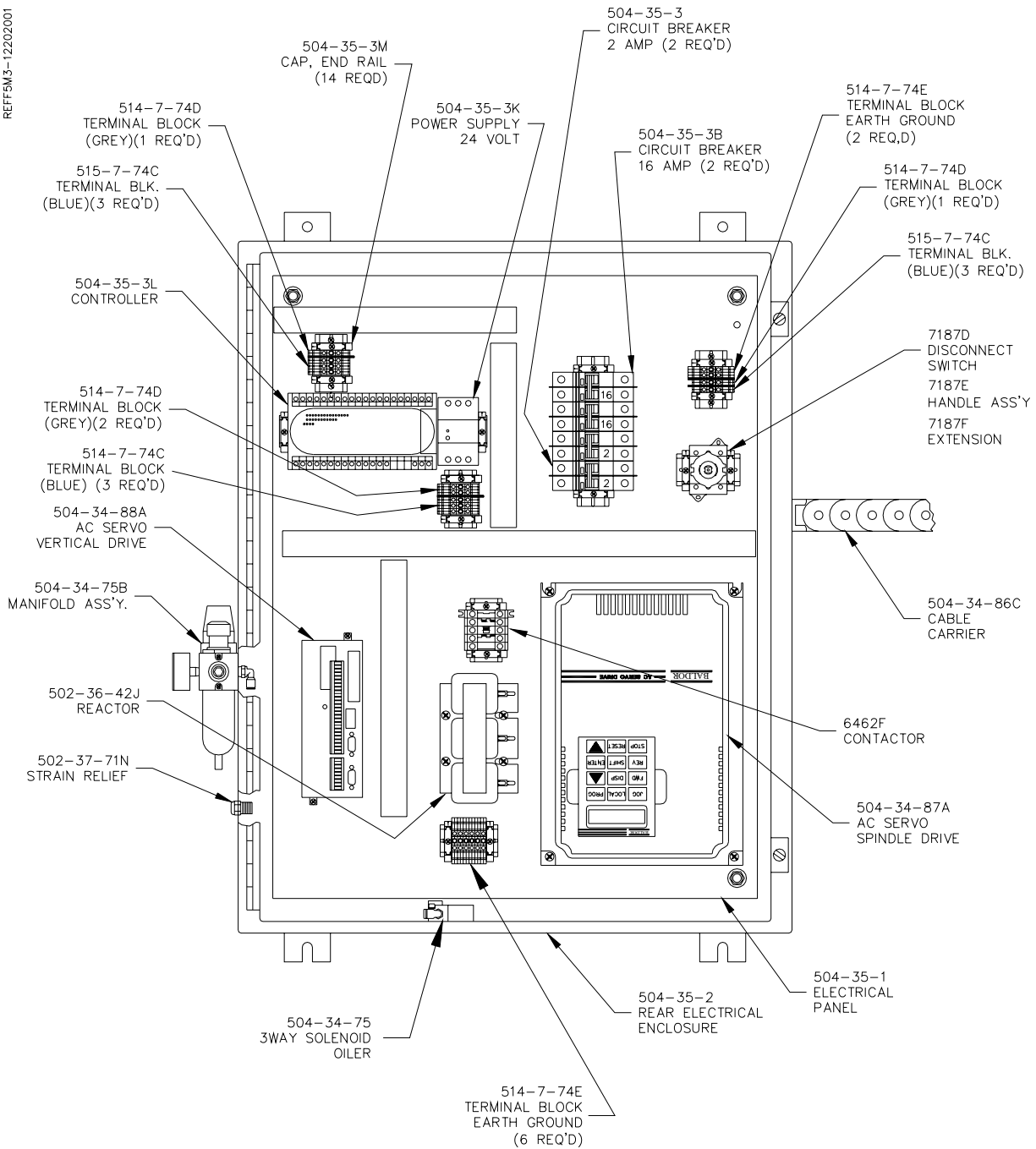

Spindle Base Assembly Illustration:

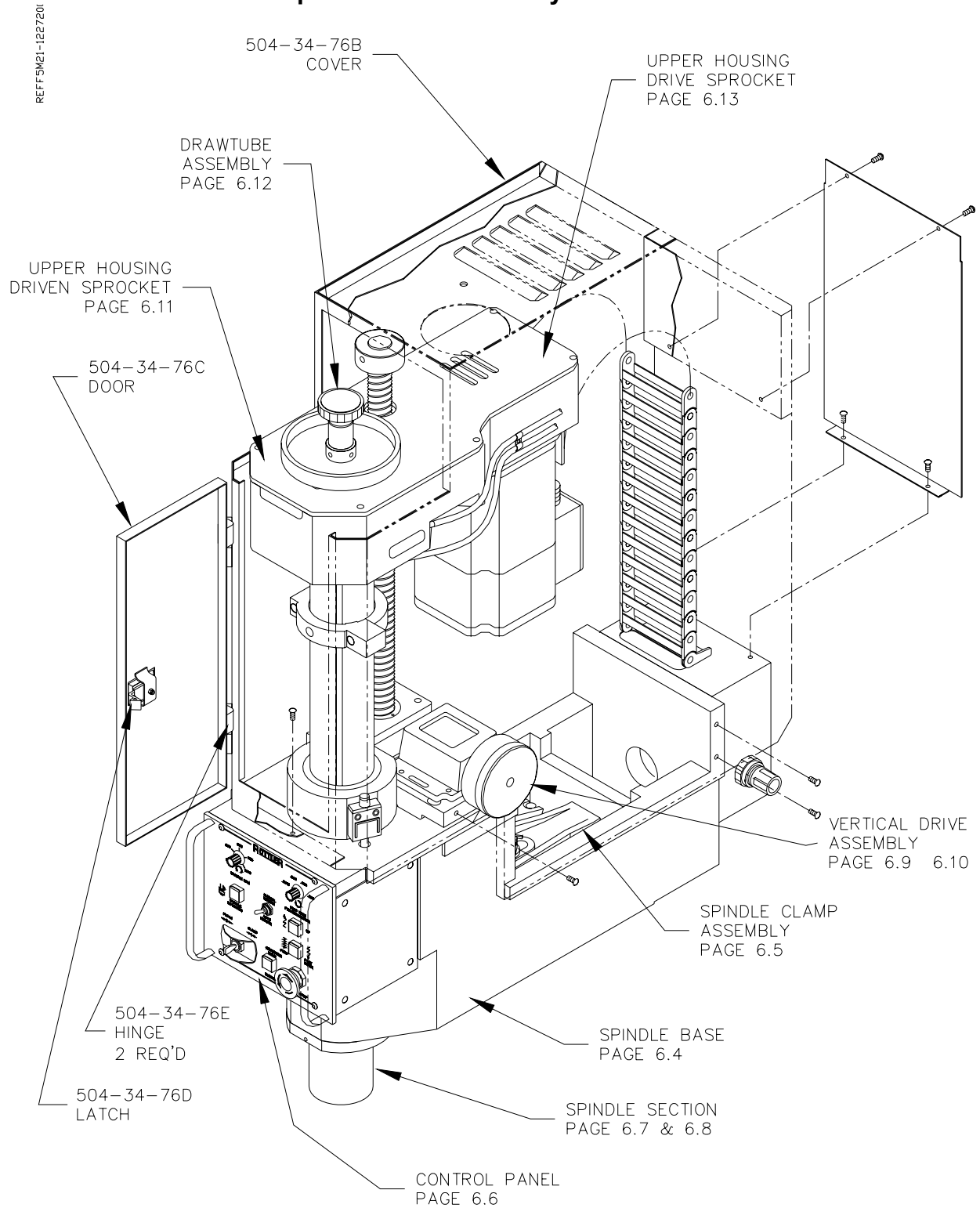

Spindle Base:

REFFSM2-010599

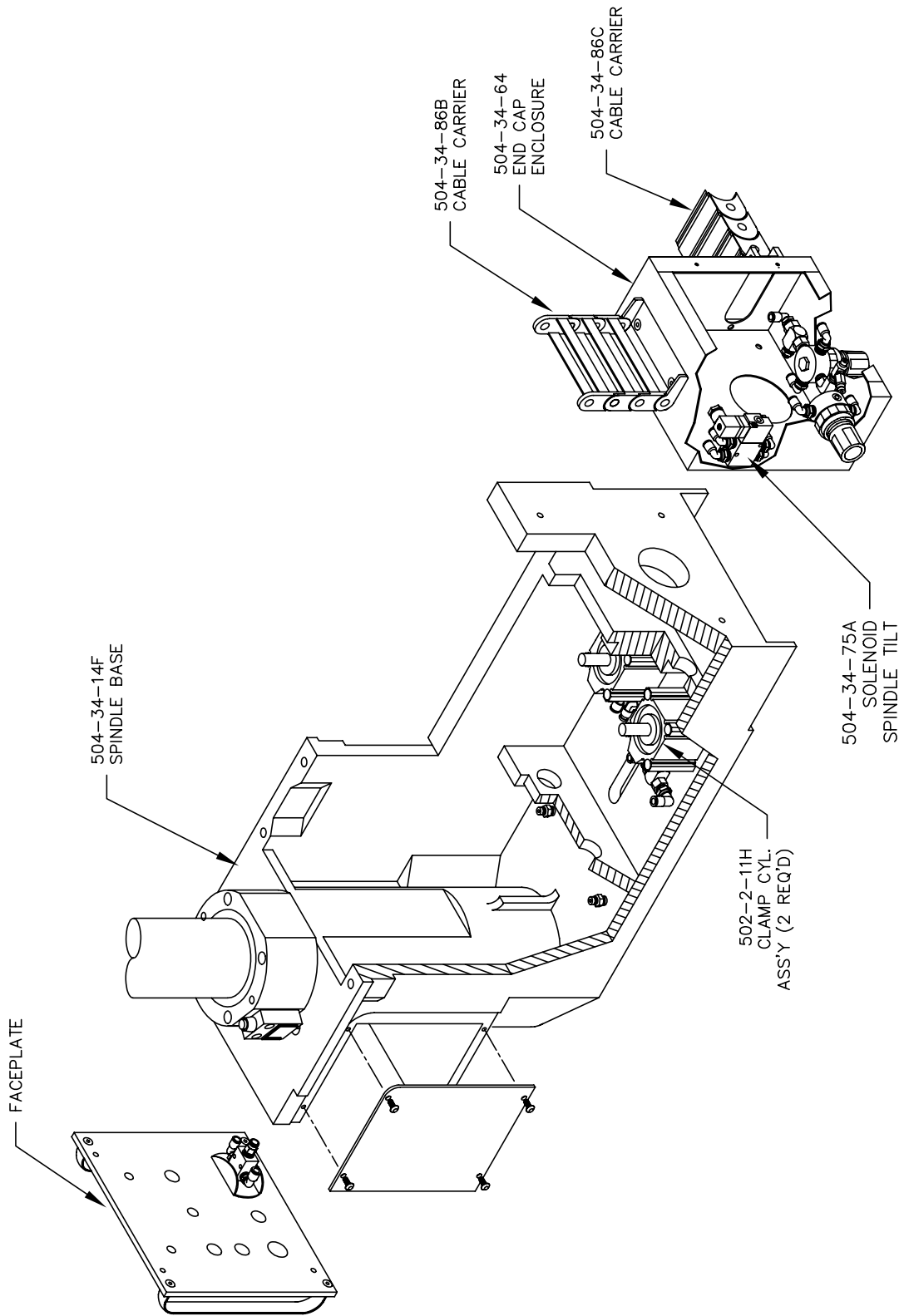

Spindle Base Clamp System:

REF F58M-07212004

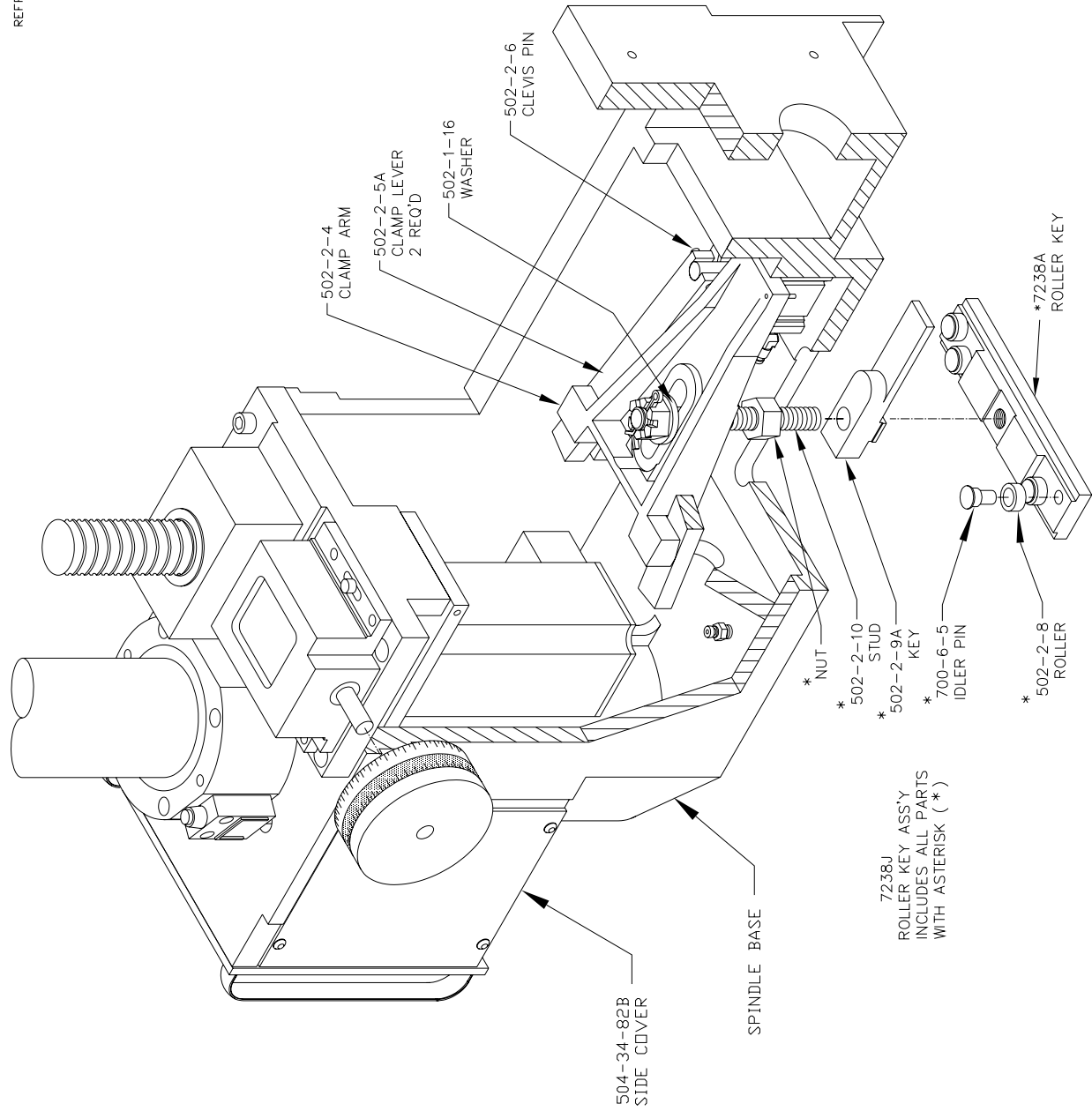

Control Panel

REF5MG-112598

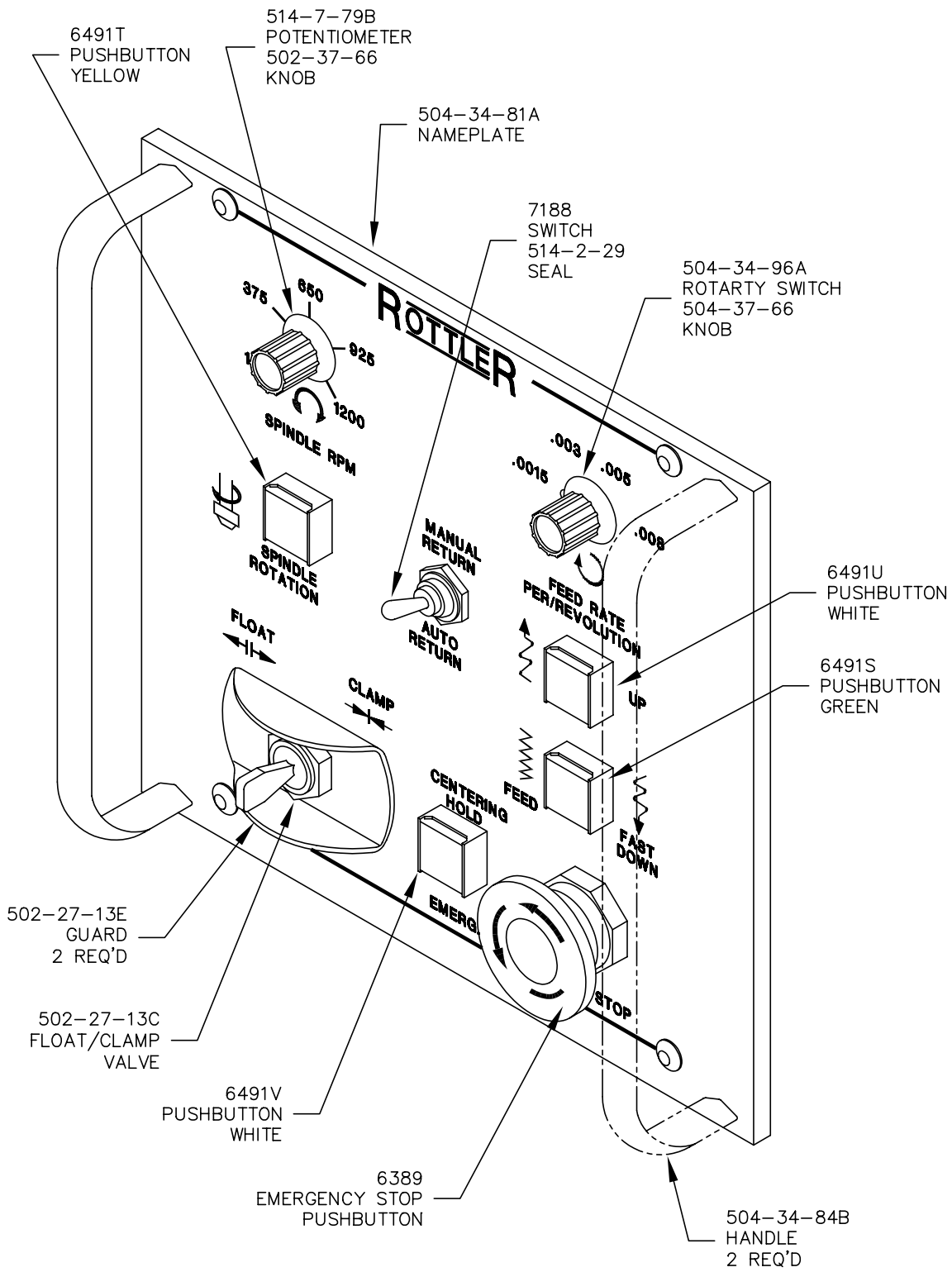

Spindle Section Type 1:

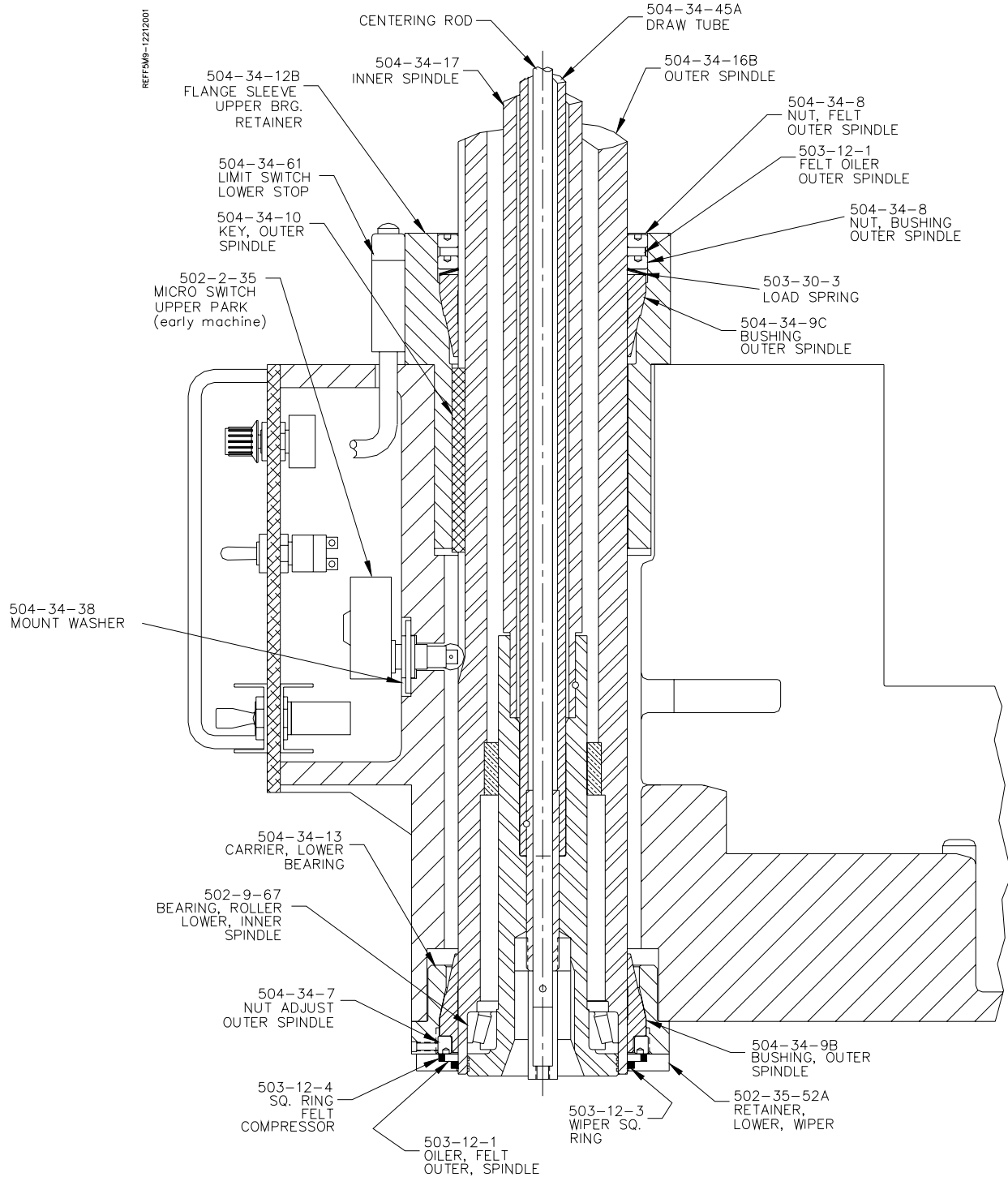

Spindle Section Type 2:

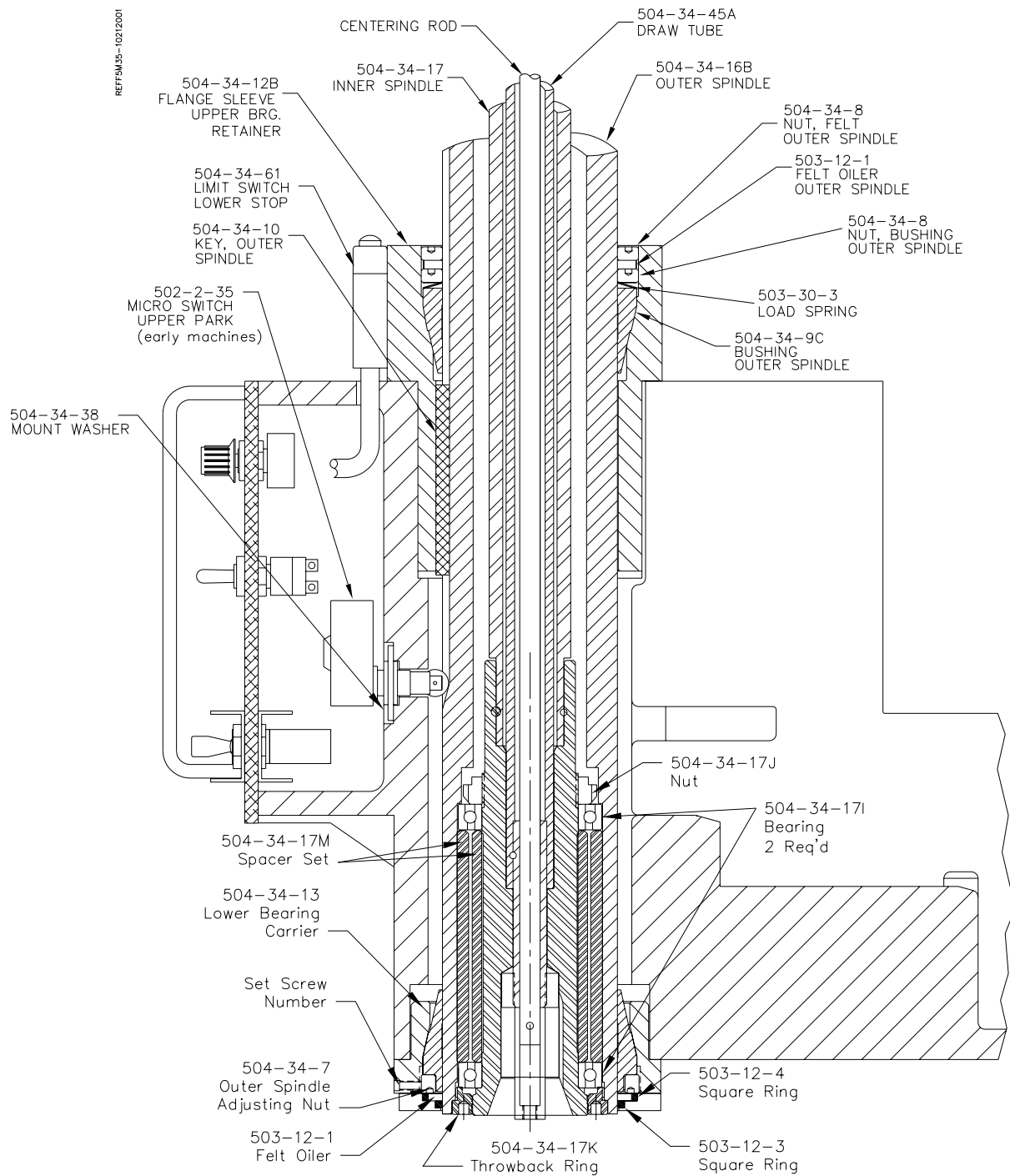

Vertical Drive Assembly: (early machine)

REFFSM12-020699

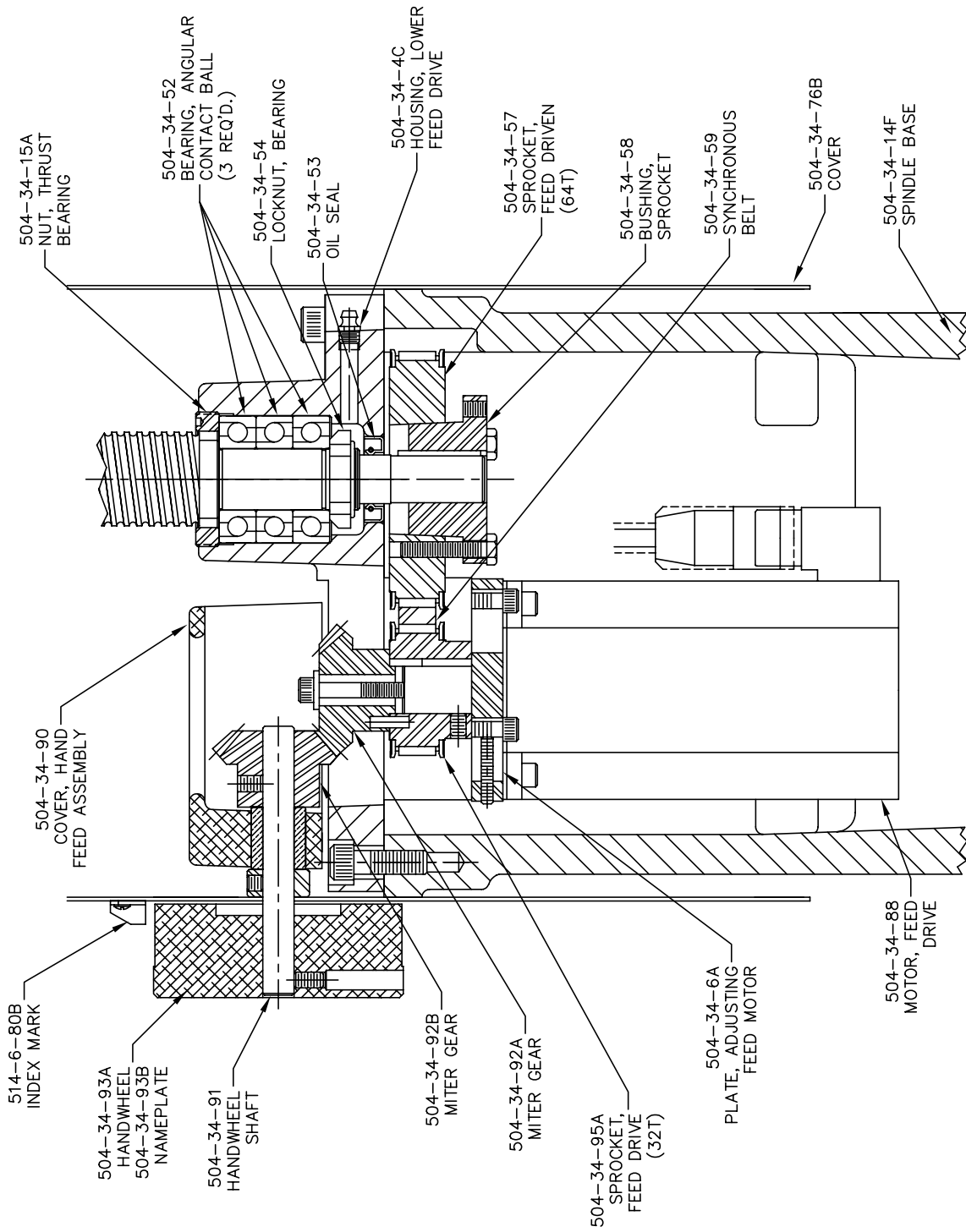

Vertical Drive Assembly:

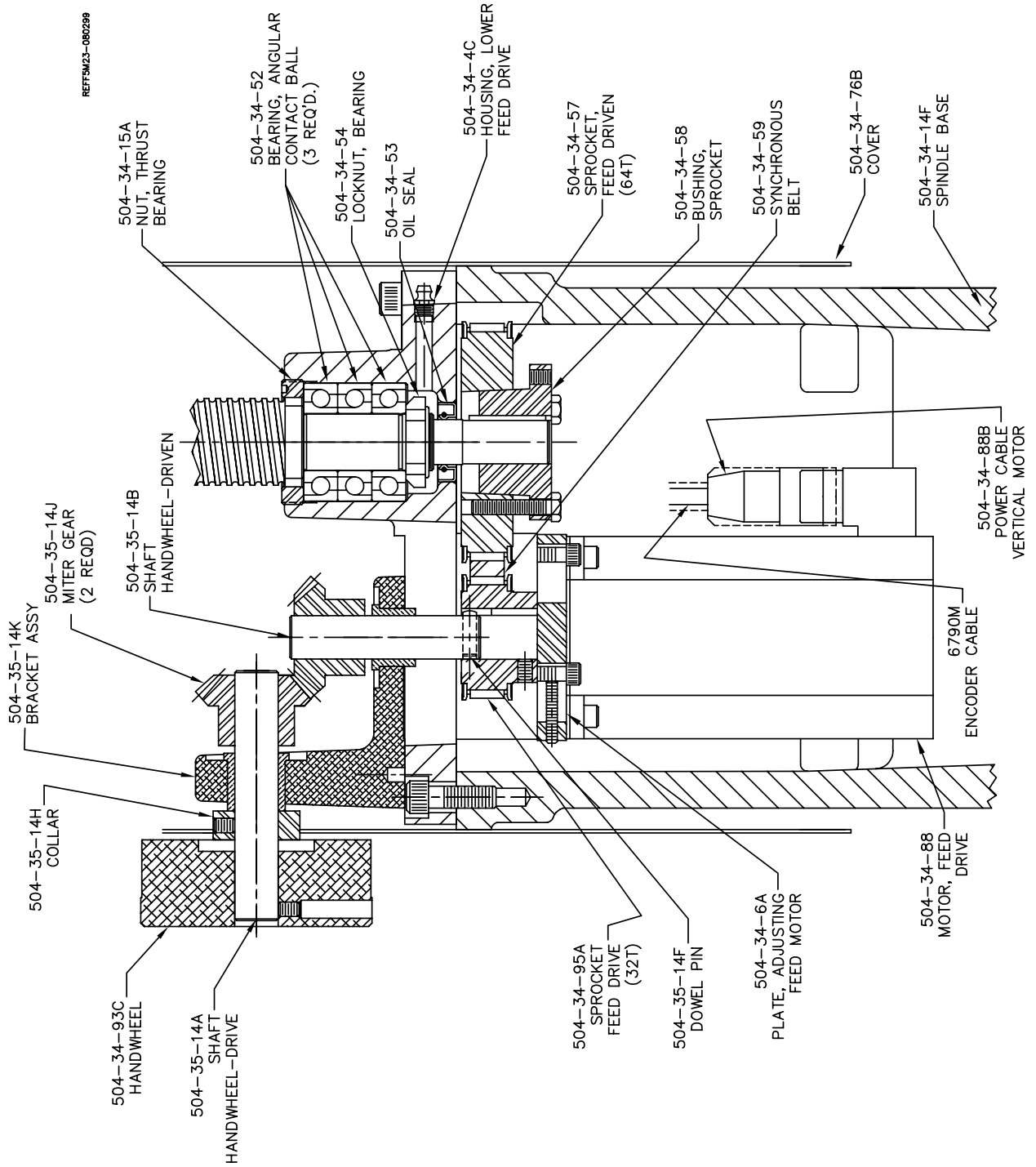

Upper Housing Driven Sprocket:

REF5M10-111198

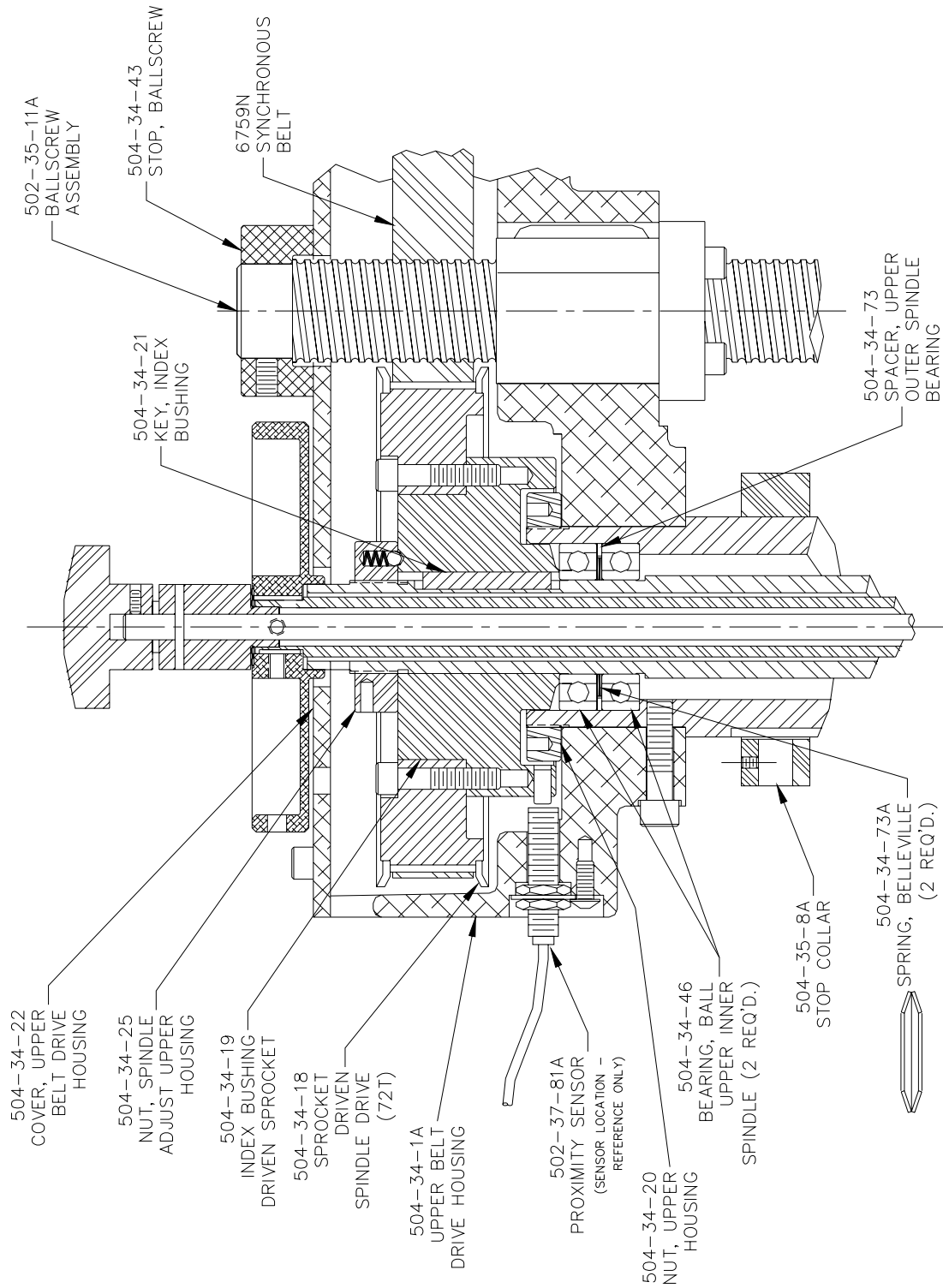

Drawtube Assembly:

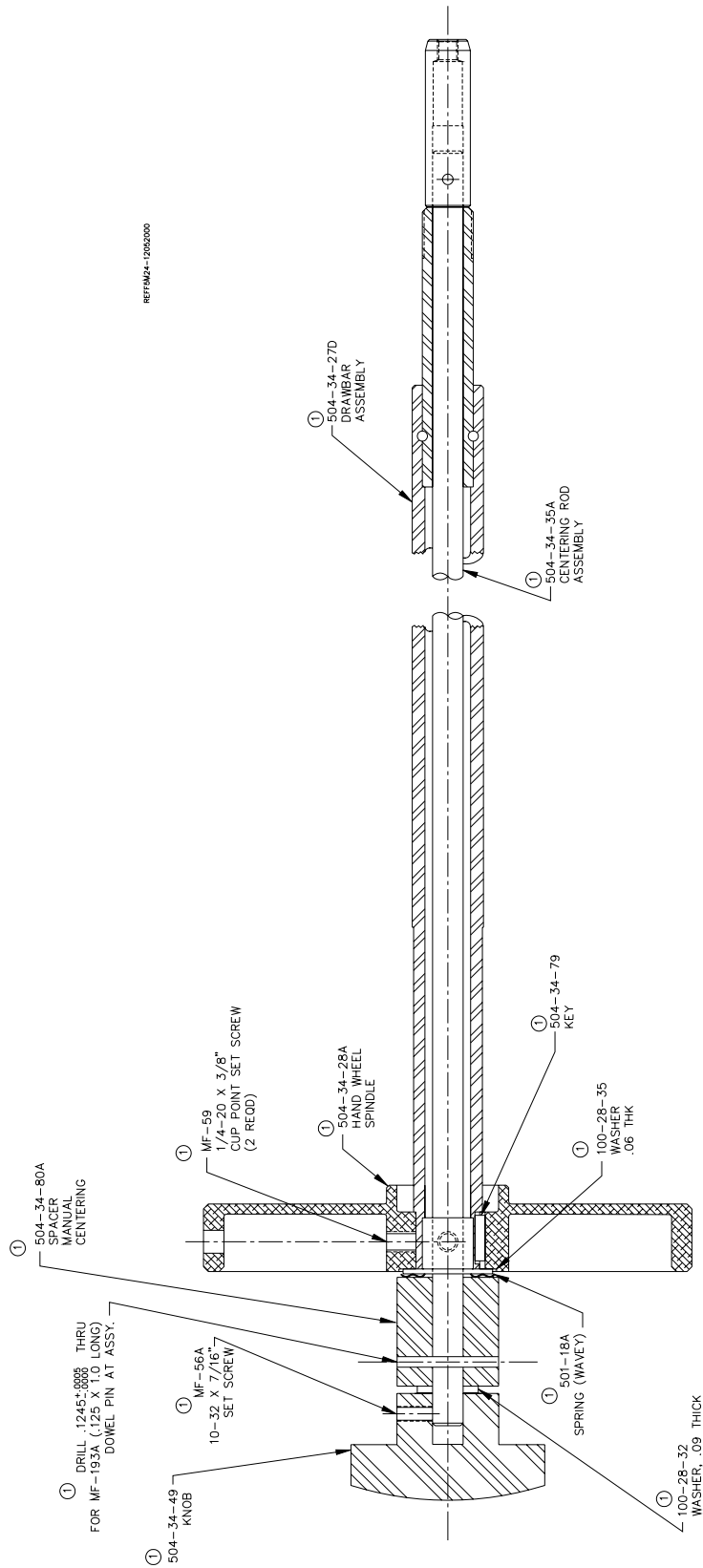

Upper Housing Drive Sprocket:

REFFSM11-020899

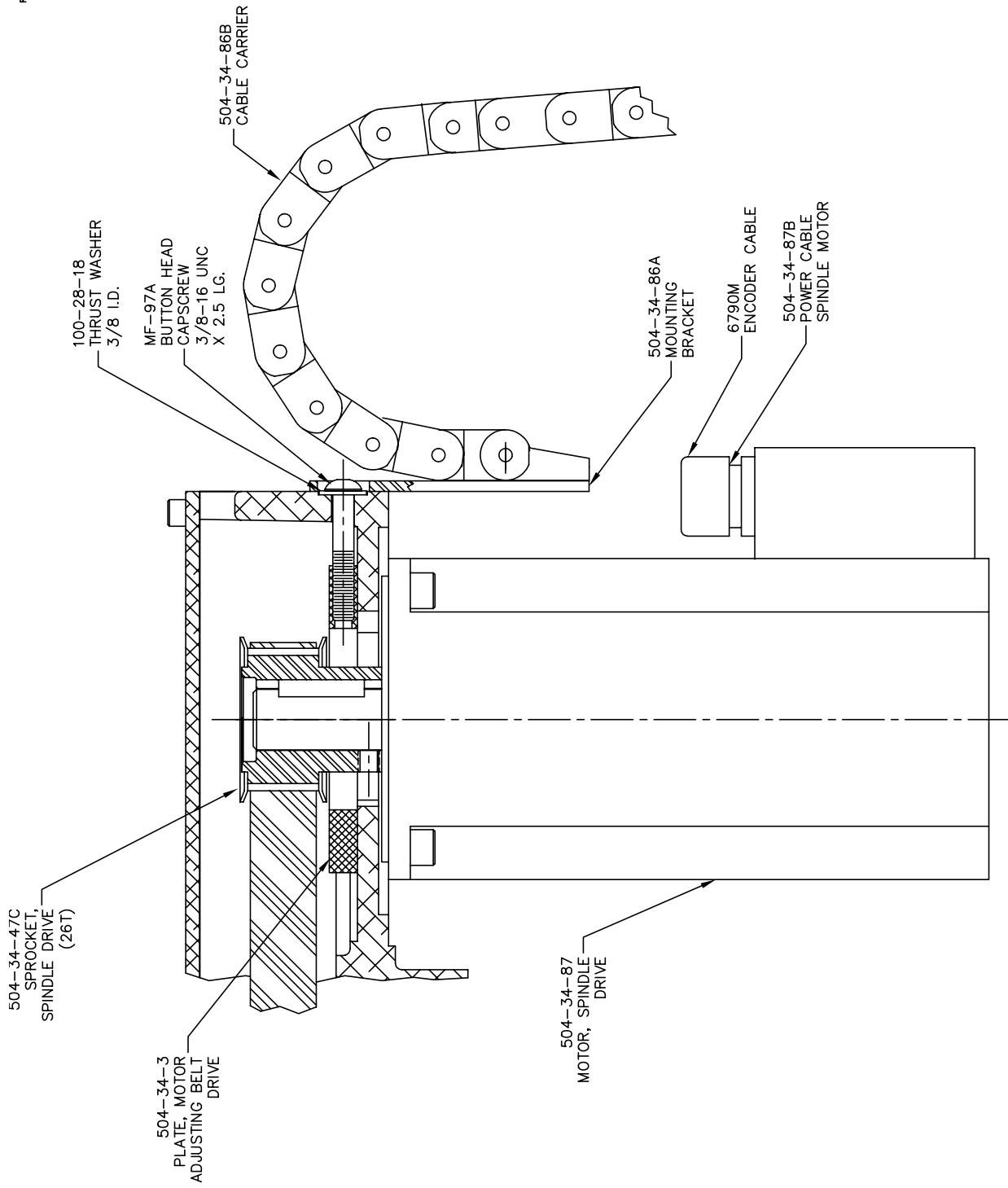

Block Clamp Assembly: 502-1-30

REFFA2EB24-010595

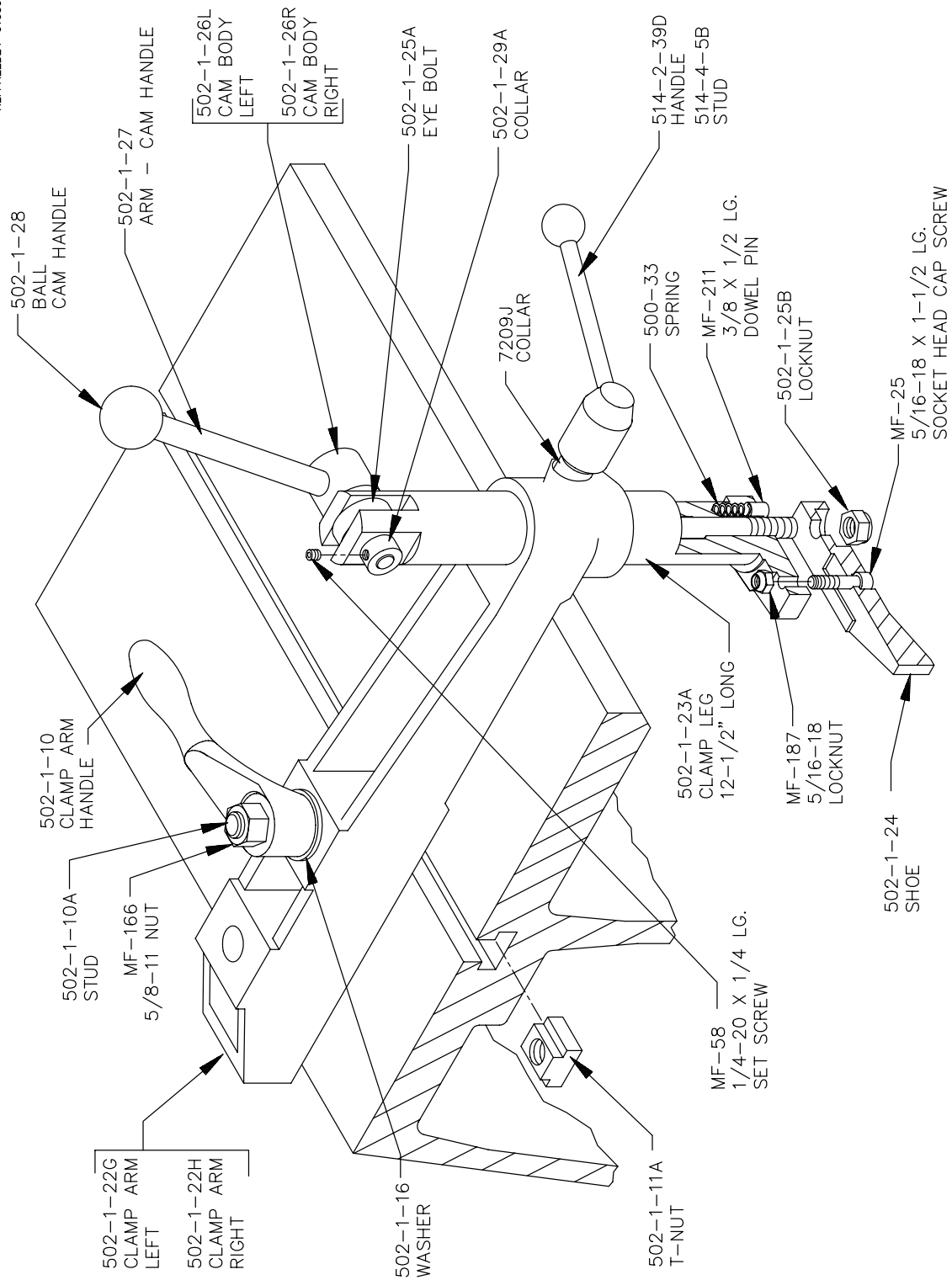

Tools:

REF5M8-12202001

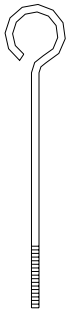

100-24
TOOL
PULLER



MICROMETER
WRENCH

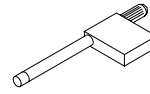

511-29-12D
TORX WRENCH

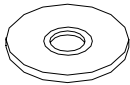

502-1-12
WASHERS
(4 REQUIRED)

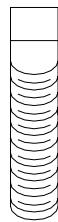

502-1-12A
JACKING SCREW
(4 REQUIRED)

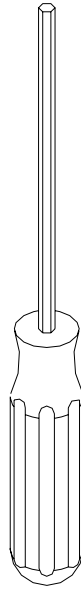

501-72
7/32"HEX
DRIVER

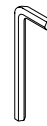

501-72H
1/4" ALLEN
WRENCH



501-72C
7/64" ALLEN
WRENCH



501-72B
3/32" ALLEN
WRENCH



501-72G
5/64" ALLEN
WRENCH

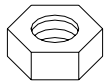

502-1-12F
JAM NUT
(4 REQUIRED)

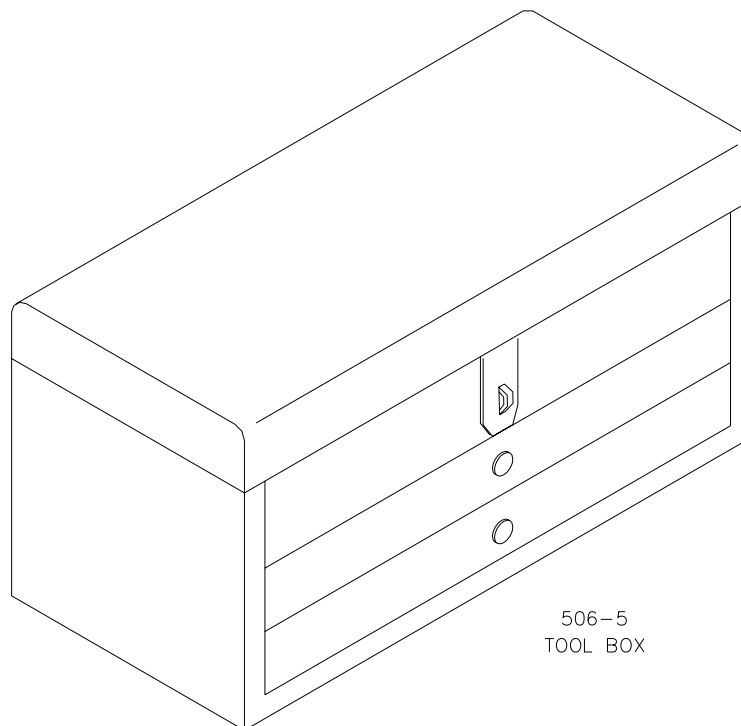

506-5
TOOL BOX