

ROTTLER

F69ATC CNC MACHINING CENTER

OPERATION AND MAINTENANCE MANUAL



MANUAL SECTIONS

INTRODUCTION

INSTALLATION

SAFETY

CONTROL DEFINITIONS

OPERATING INSTRUCTIONS

MAINTENANCE

TROUBLESHOOTING

MACHINE PARTS

OPTIONS

MSDS

ORDERING PROCEDURE

Contact your regional Rottler sales rep for assistance in ordering optional equipment, replacement parts, or tooling.

If you are unable to contact your regional Rottler sales rep, call the factory at 253-872-7050 and ask to speak to the parts sales specialist.

Have the following information handy to expedite the ordering process:

1. Your name, business name, and contact number
2. Customer number
3. If you don't have a customer number, your billing address
4. Shipping address if different from billing address
5. Machine model and serial number
6. Part number and description of what you want to order
7. Preferred method of shipment
8. You may also contact us via e-mail with the above information. Send e-mail requests to:
parts@rottlermfg.com

In some cases you may be requested to send a photo of the part you are ordering if it is a replacement part, or doesn't appear in the database.

If you are unsure which part you need to order, contact our service department and ask to speak to one of our service consultants. They will assist you in determining which part you require.

THERE IS A MINIMUM ORDER OF \$25.00

INTRODUCTION

Contents

Introduction.....	1-1
Description.....	1-2
Disclaimer	1-2
Limited Warranty	1-3
Online Documentation Access.....	1-4

Introduction

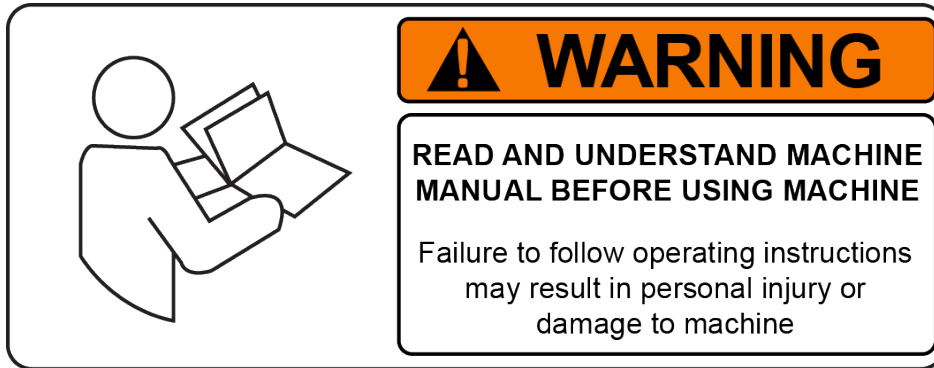

READ THE SAFETY CHAPTER BEFORE INSTALLING MACHINE. THOROUGHLY UNDERSTAND ALL SAFETY ISSUES BEFORE OPERATING MACHINE.

ATTENTION OWNER/BUSINESS MANAGER

To validate the warranty on your new Rottler machine, please be sure to sign and complete the “Installation Report” located in the Installation Chapter of this manual.

We suggest that the new user of the F69ATC read the CONTROL DEFINITIONS to get an idea how the machine operates.

The Operating Instructions chapter should be read in order to familiarize the user with the actual button pushing sequences required to carry out a job. These chapters in the manual should be considered an introduction. As the operators of the F69ATC series machines gain experience with using the different functions of the machine, complicated setups and programs will make more sense.

The rest of the manual contains information and part number reference on fixtures, cutting tools, and machine maintenance. The operator should read and become familiar with these areas as well.

Description

The model F69ATC is a precision, single point, high speed boring machine. The F69ATC can be equipped with tooling and accessories for re-boring most American passenger car and truck engines, In-lines as well as 60 and 90 degree V-types.

The F69ATC machines can be easily tooled to machines a wide range of engines, including European and Asian.

The machine is designed to maintain the alignment of cylinder bores to the Pan Rails and Main Bearing bore locations, as was done in the original factory machining. This overcomes the many inaccuracies and out-of-alignment problems associated with the clamping of portable boring bars to the cylinder head surface of the blocks.

Convenient controls, fast block clamping, air floated Spindle Base positioning and clamping, means considerable savings in floor to floor time and operator involvement.

Change over or re-setting time required to set up V-type or In-Line engines is a minimum, making this machine highly suited to the jobber shop where engines cannot be run through in model lots.

Disclaimer

The F69ATC Manual (henceforth to be referred to as the "Manual") is proprietary to Rottler Manufacturing LLC. ("Rottler Manufacturing") and no ownership rights are hereby transferred. No part of the Manual shall be used, reproduced, translated, converted, adapted, stored in a retrieval system, communicated or transmitted by any means, for any commercial purpose, including without limitation, sale, resale, license, rental or lease, without the prior express written consent of Rottler Manufacturing.

Rottler Manufacturing does not make any representations, warranties or guarantees, express or implied, as to the accuracy or completeness of the Manual. Users must be aware that updates and amendments will be made from time to time to the Manual. It is the user's responsibility to determine whether there have been any such updates or amendments. Neither Rottler Manufacturing nor any of its directors, officers, employees or agents shall not be liable in any manner whatsoever to any person for any loss, damage, injury, liability, cost or expense of any nature, including without limitation incidental, special, direct or consequential damages arising out of or in connection with the use of the Manual.

Rottler Manufacturing and its employees or representatives are not responsible for any information regarding final specifications of any workpiece that is created as a final product when using Rottler equipment. It is the responsibility of the end user of Rottler equipment to determine the final dimensions and finishes of the workpiece that they are working on. Any information regarding final dimensions and finishes that appears in any Rottler literature or that is expressed by anyone representing Rottler is to be regarded as general information to help with the demonstration of or for operator training of Rottler equipment.

Limited Warranty

Rottler Manufacturing Company Model F69ATC parts and equipment is warranted as to materials and workmanship. This limited warranty remains in effect for one year from the date of installation or two years from the date of the original shipment from Rottler or whichever date occurs first. This only applies if the machine is owned and operated by the original purchaser and is operated and maintained as per the instructions in the manual. A machine is warranted only if the Installation Report has been properly executed by a certified installation person and received by Rottler at the time of actual installation.

The products are warranted upon delivery to conform to their published specifications and to be free from defects in material and workmanship under normal use for a period of one year from shipment. Should a product not be as warranted, Rottler sole obligation shall be, at its option, to repair, correct or replace the product or to refund the amounts paid for the Product upon its return to a location designated by Rottler. No warranty shall extend to rapid wear Products (including tooling) or to Products which have been subject to misuse (including any use contrary to Rottler instructions), neglect, accident (including during shipment), improper handling or installation, or subject to any modification, repair or service not certified by Rottler. Rottler shall not be liable for any consequential, direct or indirect damages or for any other injury or loss. Buyer waives any right, beyond the foregoing warranty, to make a claim against Rottler. No warranty is provided for any Products not paid in full. Merchandise cannot be returned to Rottler without prior approval. Customer must contact the Order Department or representative to get approval and to be issued a Return Goods Authorization number (**RGR#**). Merchandise authorized for return must be returned prepaid. If merchandise is returned with shipping charges collect, the actual amount of these charges may be deducted from any credit which may be due the customer. The **RGR #** assigned by the Order Department should be written on the shipping label and must appear on a copy of the invoice(s) covering the original shipment. This invoice copy must be included in the box with the parts. Shipment must contain **ONLY** those items on the **RGR** as approved for return. Merchandise must be received within 10 days of the date of **RGR** or the **RGR** will be canceled. All returned merchandise may be subject to a 20% restocking fee on under \$1,000.00 amount or 10% on any items over \$1,000.00. Parts or tooling over 30 days old are considered as customer property and can only be returned with prior written approval from Rottler Corporation Management and/or Shipping Department.

The issuance of a **RGR DOES NOT** guarantee credit - it is only authorization for the return of the goods. Credit for return merchandise is at the sole discretion of Rottler. Credit will be issued only after inspection of returned goods.

Tools proven to be defective within the warranty period will be repaired or replaced at the factory's option.

We accept no responsibility for defects caused by external damage, wear, abuse, or misuse, nor do we accept any obligation to provide compensation for direct or indirect costs in connection with cases covered by the warranty.

Online Documentation Access

Online documentation for machines and optional equipment can be accessed at the Rottler website. To access documentation open your browser and navigate to <https://www.rottlermfg.com>.

Scroll to the bottom of the page and under the Owner Resources title click the type of documentation you want to access.

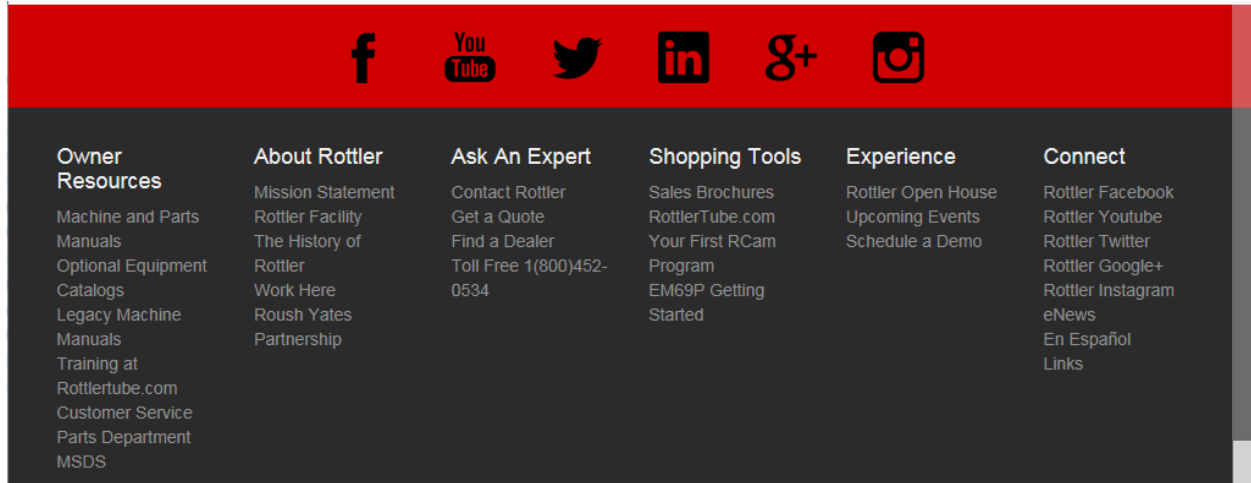

If a log in window pops up asking for user name and password fill in the blanks as shown.

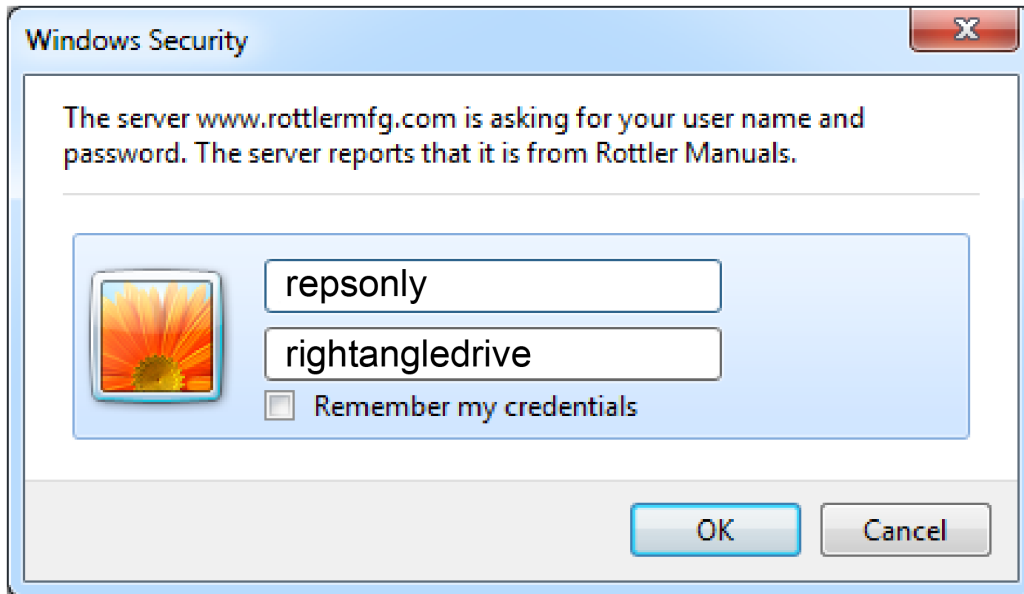

This page intentionally left blank

INSTALLATION

Contents

F69ATC Installation Report.....	2-2
Machine Dimensions.....	2-8
Front Dimensions	2-8
Side Dimensions	2-9
Clearance Dimensions	2-10
Installation Procedure.....	2-11
Location.....	2-11
Unpacking and Lifting.....	2-11
Type One	2-12
Type Two	2-12
Leveling and Alignment	2-13
Leveling Bolt Locations	2-14
Air Supply.....	2-15
Power Supply.....	2-16
Grounding.....	2-17
Getting Started.....	2-18
Power Up	2-18
Shipping Restraints.....	2-20
Spindle Support.....	2-20
Counter-Weight Bar and Bolt	2-21
Creating a Skype Account.....	2-22

ATTENTION OWNER/BUSINESS MANAGER

To validate the warranty on your new Rottler machine, please be sure to sign the installation report after the installation technician has installed the machine and verified the machine is operating correctly and given the operators operation and maintenance training.

Thank you for your cooperation and the opportunity to be of service to you.

ROTTLER MANUFACTURING



INSTALLATION REPORT

F69ATC
REV 062718

OFFICE USE ONLY
Route to: Servicer Mgr → Accounting → Andy → Accounting **Warranty Exp Date**

ROTTLER MANUFACTURING MUST HAVE THIS REPORT RETURNED TO PROPERLY QUALIFY WARRANTY ON EQUIPMENT

Customer: _____ Address: _____
City: _____ State: _____ Zip: _____ Phone: _____
Country: _____
Machine Model: _____ Serial Number: _____ Representative: _____

MACHINE INSTALLATION: Electrical information MUST be complete to validate this report.

_____ Customer has read and fully understands importance of machine location as explained in the installation section of the manual.

Customer/Sales Rep responsibility prior to the arrival of Rottler Sales/Service technician. Please Initial each item when it is completed.

- _____ Remove machine from truck.
- _____ Remove fixturing and misc. from machine and clean.
- _____ Remove rust inhibitor from machine surfaces. Remove X,Y and Z axis way covers clean with mineral spirits, WD40 or kerosene and do not reinstall.
- _____ Install machine with jack pads under jacking bolts. Refer to the Installation section of the F69ATC manual for proper uncrating and leveling instructions.
- _____ Customer is responsible for providing electricity to machine in a manner that meets the local electrical code requirements.



VERY IMPORTANT: Modern design machines contain electronic low voltage circuitry that provides great advantages and a better machine life. BUT, you must have an excellent, stable, isolated power supply along with an isolated ground. If not, electrical noise problems are likely to interfere with machine operation unexpectedly.

- _____ Have Internet connection available for the machine. Either via Ethernet cable or Wireless. The machine comes equipped with a wireless USB adapter.
- _____ The F69ATC machine must have a ground rod installed. Not having a ground rod installed can cause unexpected movement of the machine. Refer to the Operation Manual for correct installation of the ground rod.
- _____ Briefly describe the isolated ground connection to the machine you have made:

- _____ Air of the proper pressure and capacity connected to the machine. Air supply must be free from oil and water. Oil or water will damage electrical and air components.
- _____ This machine requires between 208 and 240 Volts AC, Three Phase, 50/60 Hz, isolated power supply. For voltages above 240 or below 208 VAC, a 17kva transformer will be required and is available at Rottler. Please specify voltage when ordering. Measure the incoming voltage between L1 and L2, L2 and L3, and L1 and L3. Current requirements for this machine is 50 amps. Measure the incoming AC voltage at least twice during installation.
1. L1to L2 _____ VAC, L2 to L3 _____ VAC, L1 to L3 _____
 2. L1to L2 _____ VAC, L2 to L3 _____ VAC, L1 to L3 _____
- _____ Measure each leg of the incoming supply to ground. Sometimes you may find a "high" leg to ground. When this happens make sure the high leg is running to L3.
L1 to ground _____ VAC L2 to ground _____ VAC L3 to ground _____ VAC

CAUTION Neutral and machine ground are not the same thing. You should measure an open circuit between Neutral and ground.

CAUTION IF VOLTAGE IS OUTSIDE THE CORRECT RANGE AT ANY TIME THE MACHINE WILL NOT OPERATE PROPERLY AND MAY BE DAMAGED.

- _____ Customer should attempt to have junk work piece available.
- _____ Have the operator read through the operation manual before training begins. This will help him be familiar with the button pushing sequences. Have the operator read through the manual again after training and some of the sequences will make more sense.
- _____ Remove the ball screw locks on the left side of the table for the X axis, and the front of the table for the Y axis. They may be covered up by the way covers.
- _____ Place a thin film of silicone on one side of the ball screw caps and install them in place of both the X and Y axis locks.

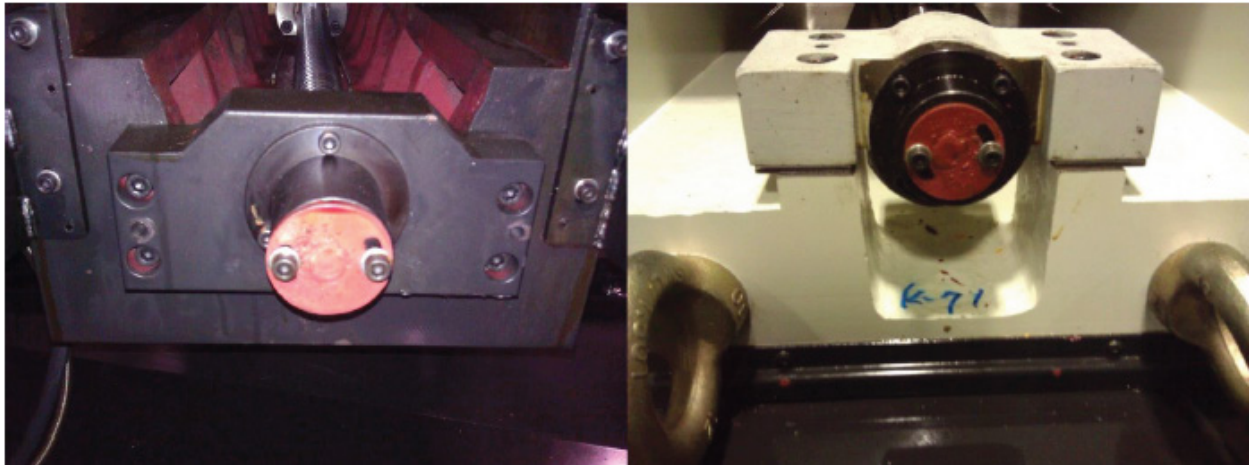

Rottler Technician Installation checklist

- _____ Install toolholder drum if machine was shipped with it removed.
- _____ **BEFORE** turning power on to the machine: Check all wires for security by gently tugging on the wires and then use the correct screw driver, turning CW until movement stops. Stranded wire can "spread" slightly from vibration during transport.
- _____ Install electrical component covers inside the electrical enclosure with fasteners provided.

- _____ Clean remaining rust inhibitor from the machine surfaces. Remove the way covers from the front and back of the Y (In/Out) Axis. Clean the rust inhibitor from exposed areas of the In/Out and Vertical axis. If the side trays for the Horizontal have been put on the machine, remove them. Use cleaner such as WD40 or Kerosene to clean the ways. Remove way wipers and clean each wiper.
- _____ Remove all rust inhibitor from the axis way surfaces.

 **CAUTION** *Do not attempt to move any axis until all rust inhibitor has been removed.*

- _____ Reinstall way wipers. Confirm that all wipers make full contact with way surfaces.

Note: The positioning of the machine in small increments will be detrimentally affected if all rust inhibitor is not removed from the ways.

- _____ Remind customer of the proper air pressure and capacity connected to the machine. Air supply must be free from oil and water. Oil or water will damage electrical and air components.
- _____ Connect electrical wires in main rear enclosure if required using machine wiring diagram.
- _____ When installing the way covers on the ends of the table. If there is not weather stripping on the mating surfaces. Put a bead of silicone on one of the mating surfaces before installing the covers. This will keep chips from getting between the two and dropping onto the horizontal turcite.
- _____ Install and test the Internet connection to the machine. DO NOT download any updates unless instructed to do so by Rottler.

 **WARNING**

- _____ Explain to the customer and operator that at NO time is there to be any software or hardware other than Windows Auto Update and Rottler installed on this machine. This includes screen savers, anti-virus software, and any hardware device that installs software on the machine. Installation of screen savers and anti-virus software can cause dangerous control problems. Any installation of software or hardware will void the warranty on the machine.
- _____ Explain to the customer the proper way for turn the machine off when it is not in use. Do not leave the machine on overnight. It is important to close all programs followed by shutting down Windows before turning the main power switch off. Do not turn the main power switch off before shutting down Windows.
- _____ Explain to the customer and operator that the machine should be hooked up to the Internet anytime it is on. The software on the machine will automatically connect to our server to send back useful information on machine status.
- _____ Connect customer supplied Internet to the machine. Verify that the Internet is accessible from the machine.
- _____ Once the machine has been fully setup and is ready for operation create a Skype account for the machine following the instructions in the Installation Section of the manual.
- _____ Explain to the customer and the operator how the to log onto Skype and communicate with Rottler when needed.

 **WARNING**

- _____ Computer Viruses will cause the machine control system to become unstable. This may cause the machine to make uncontrolled moves which could create a dangerous environment for the machine operator.

IMPORTANT

Refer to Chapter 4, Control Definitions of the Machine Manual, Section: Computer and Controller System Safety. Explain and discuss this section carefully with Owner/Manager/Operator and have them sign off. Failure to do so will result in the machine warranty being Null and Void.

Signature / Title

Explain to the customer the importance of backing up the block profiles to a separate device. Any computer failure or possible operator input error can result in the loss of all block profiles that were created for the machine. Refer to Chapter 5 of the machine manual for detailed instructions on backing up and restoring block profiles.

MACHINE START-UP



When starting the machine for the first time, it may move out of control. Make sure all hands are clear of machine parts. Be ready to press the Emergency Stop button if needed.

_____ Turn main power on at the main disconnect switch located on the rear enclosure.

If machine moves out of control, turn power off and contact factory for help in trouble shooting.

If any of the circuit breakers "trip", reset and call factory for possible trouble shooting.

MACHINE MOVEMENTS

_____ Make sure there is nothing obstructing the full vertical or horizontal travel of the machine taking special notice of the way travel and top of the spindle unit.

_____ Put the machine in hand wheel mode and verify Z Axis operation. Put an indicator on the cutterhead and verify .001" movement per detent, if not correct adjust backlash after machine has been oiled properly.

_____ Put the machine in hand wheel mode and verify X Axis operation. Put an indicator on the cutterhead and verify .001" movement per detent, if not correct adjust backlash after machine has been oiled properly.

_____ Put the machine in hand wheel mode and verify Y Axis operation. Put an indicator on the cutterhead and verify .001" movement per detent, if not correct adjust backlash after machine has been oiled properly.

_____ Use the rapid buttons and verify proper vertical and horizontal travel.

_____ Move the machine to its vertical limits and verify maximum upper and lower limit operation.

_____ Move the machine to its horizontal limits and verify operation of the left and right maximum limit operation.

_____ Start the spindle and verify operation at all speeds.

_____ Use the spindle creep buttons and verify proper operation.

_____ Level the machine:

INSTRUCTING THE OPERATOR

Note: Rottler employees and representatives per company policy are not permitted to provide end user of Rottler equipment with any OEM specifications for the workpiece that is created by end user using Rottler equipment.

- _____ Using the operating manual as a guide explain the function of all buttons.
- _____ Cycle all machine movements and supervise the handling of same by operator.
- _____ Demonstrate the differences of Manual and Auto operation.
- _____ Fully explain the entire Auto Cycle from Centering to Auto Retract.
- _____ Explain machine parameters and error messages. It is very important that the customer does not change parameter settings without first checking with Rottler Manufacturing. If certain parameters are changed the machine may make uncontrolled moves or not operate at all.
- _____ Point out safety features to customer and operator. **Do not push any buttons without thinking of safety first.**



CAUTION

Do not assume the cutterhead micrometer has been calibrated.

- _____ Install a work piece in the machine and perform an undersize test bore to qualify the micrometer setting to the customers measuring tools.
Note adjustments: + _____, - _____.
- _____ Explain precision reset of tool in cutterhead.
- _____ The following is a checklist to go through every time the machine is started to begin a cut or automatic cycle.
 - Work piece secure
 - RPM set
 - Feed Rate set
 - Correct program in use
 - Program oriented correctly (vertical zero at correct place) Guards in place
 - Cutterhead secure
 - Tool holder adjusted to the correct size
 - Tool holder locked in place
- _____ Proceed to have operator bore block to size.
- _____ Demonstrate and explain boring with the electronic hand wheel.
- _____ Fully demonstrate full and partial clamp force use.
- _____ Explain and demonstrate the correct feed rates and speeds for carbide, CBN, PCD and coated inserts.
- _____ Cutter head change and expected stub bar performance.
- _____ Parts ordering:, refer to the operating manual for part numbers and description.
- _____ Offset tool bits, calibration of micrometer and anvil setting.
- _____ Review Emergency stop procedure with operator per operating manual.

MAINTENANCE SECTION

- _____ Use the manual as a reference when explaining routine maintenance and lubrication.
- _____ Overload devices, There are no mechanical overload devices on this machine. The machine is protected from overload by the motor controllers. If the system is overloaded the controllers shut the motors off. The controllers can be reset by turning the main power off for at least 1 minute, then turning it back on.
- _____ Micrometer and anvil thread adjustment.
- _____ Inspection of tool bit hole in tool holders (deformation due to accidental impact).

Rottler Manufacturing and its employees or representatives are not responsible for any information regarding final specifications of any workpiece that is created as a final product when using Rottler equipment. It is the responsibility of the end user of Rottler equipment to determine the final dimensions and finishes of the workpiece that they are working on. Any information regarding final dimensions and finishes that appears in any Rottler literature or that is expressed by anyone representing Rottler is to be regarded as general information to help with the demonstration of or for operator training of Rottler equipment.

Note: Rotter employees and representatives per company policy are not permitted to provide end user of Rottler equipment with any OEM specifications for the workpiece that is created by end user using Rottler equipment.

General remarks on machine performance, adjustments as received and any further organization or parts required to complete the installation.

Instructions given to: _____

Sales/Service Engineer: _____ Date _____

Shop Foreman/Superintendent or Owner: _____ Date _____

**Once completed send this form to:
Rottler Manufacturing
attn: Service Manager
8029 S 200 St
Kent, WA 98032 USA**

**Alternately you may send this form via fax or e-mail:
fax: [+1] 253-395-0230
e-mail: service@rottermfg.com**

Machine Dimensions

Front Dimensions

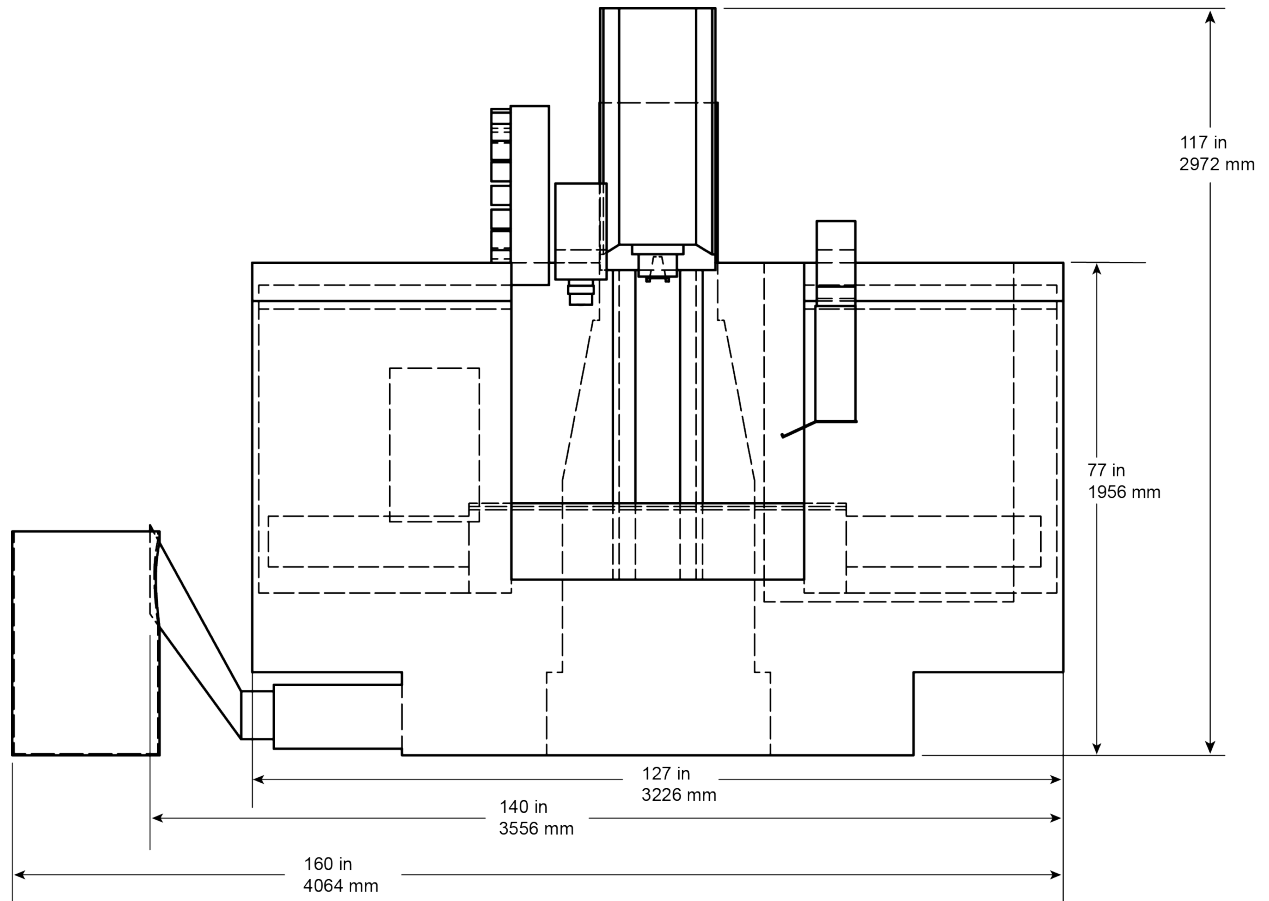

Side Dimensions

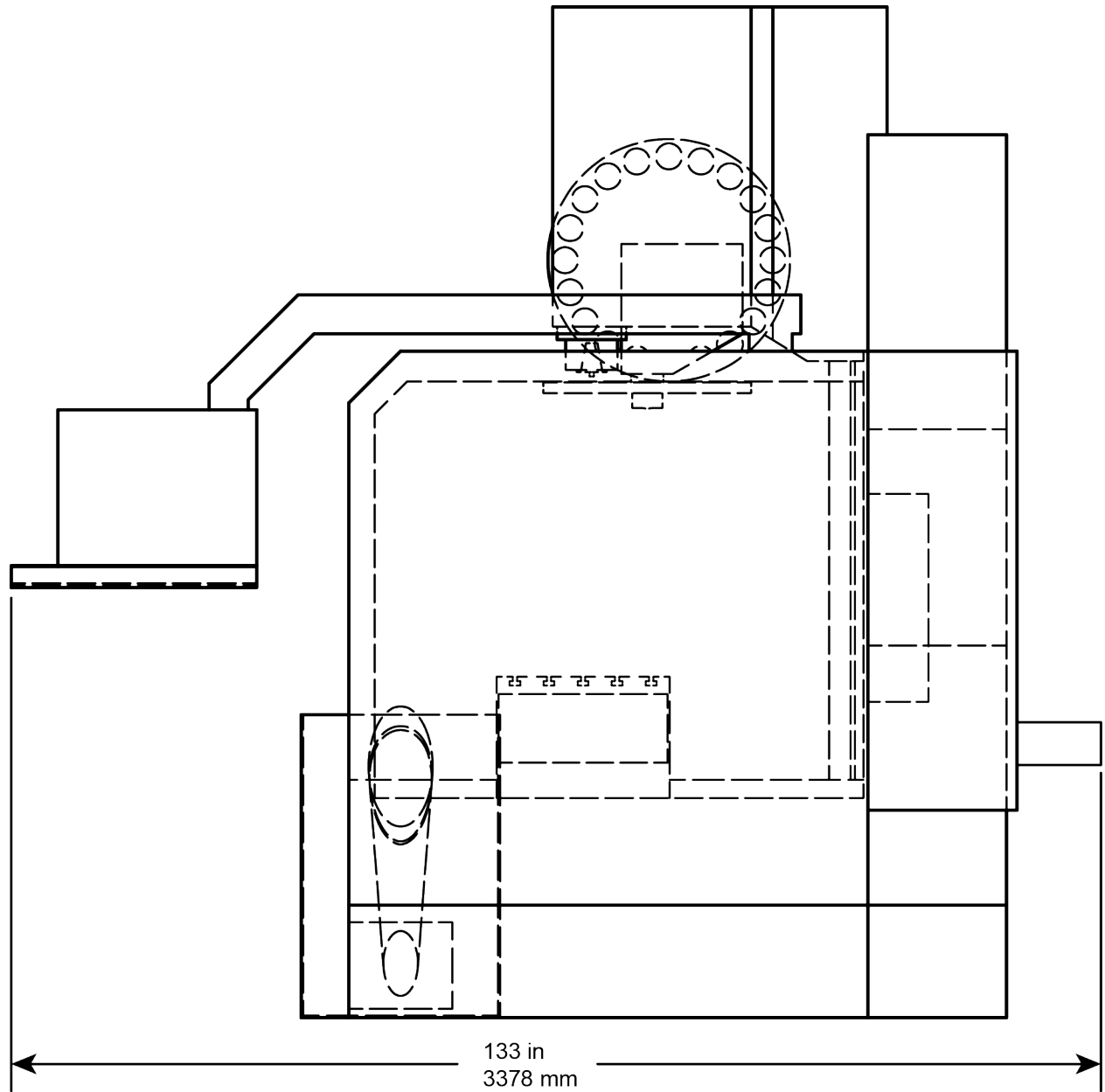

Clearance Dimensions

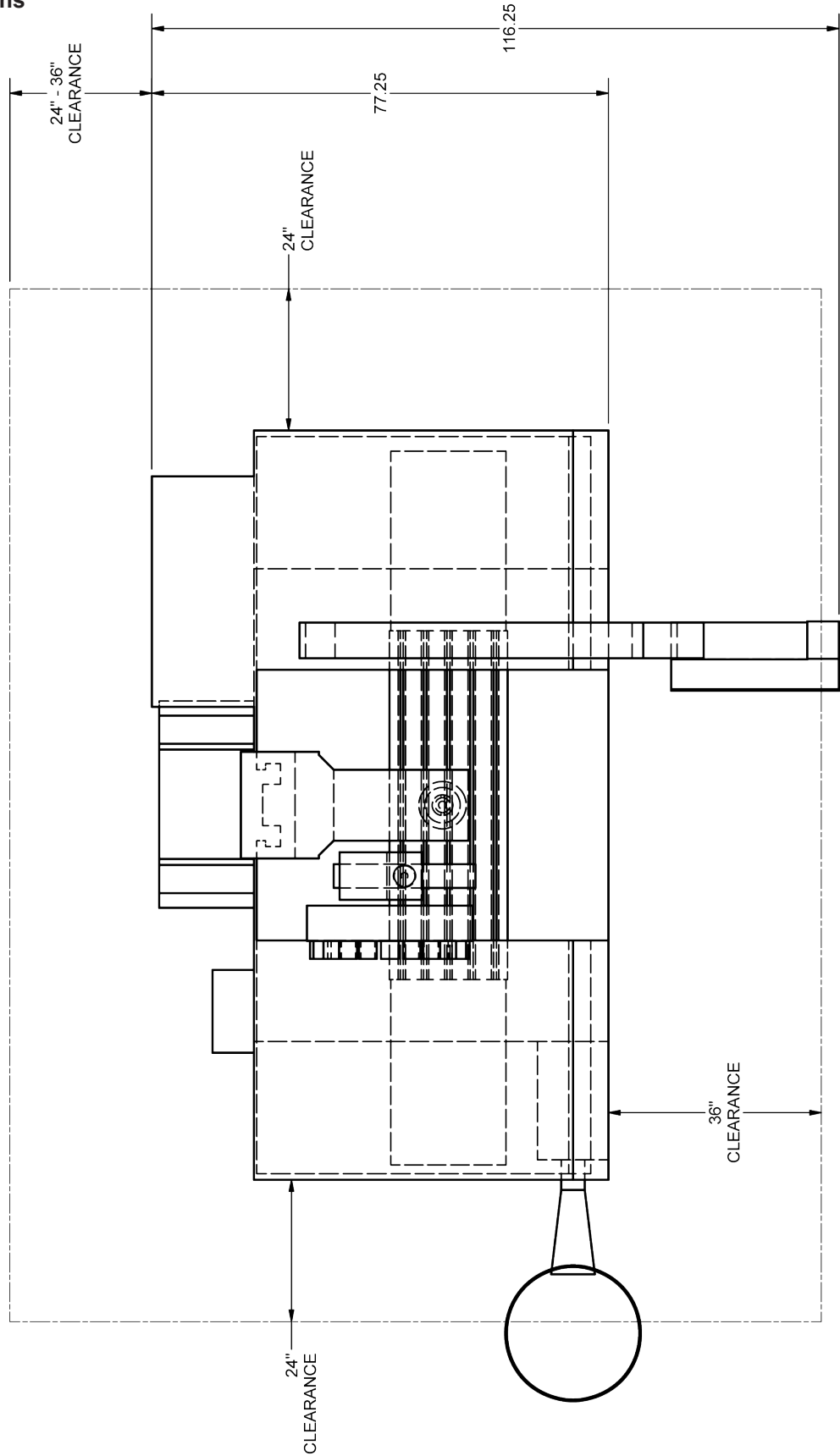

Installation Procedure

NOTE: Pictures and drawings are examples only, they may not match your machine exactly. Many drawings are shown without the outer shields in place



IMPORTANT! Placement of Machine

It is critical that the machine be placed in an area of the facility that has a stable thermal environment. The machine should be kept away from direct sunlight, large heating units, and doorways that would allow outside air direct contact on the machine.

Exposure to the above and other extremes in temperature will cause thermal drift to occur in the machines which could have a detrimental effect on machining accuracy. A number of unrepeatability errors in machine performance have been linked to this condition.

Location

The productivity of the F69 ATC will depend a great deal on the proper initial installation. Pay particular attention to the means by which work pieces are lifted into and out of the machine as well as the material handling to and from other operations in your shop. The proper loading arrangements and work location for your F69 ATC is extremely important.

A slow travel (6' to 10' per minute) power hoist, operated from either a bridge or jib crane arrangement works very well. A 1000 lb. is generally adequate for lifting most engine blocks. An air hoist with speed control makes an ideal method for fast, efficient loading and unloading.

For shops where large production runs are anticipated, the work pieces should be loaded and unloaded directly from a conveyor. If this is not the case, we suggest you pay considerable attention to the crane so that it covers an adequate area to allow the operator to back up and remove work pieces without creating a cluttered, dangerous work area.

Unpacking and Lifting

Use care when removing the crate materials from the machine. Be careful not to use force on any part of the machine.

Remove the Nuts and Jam Nuts from the Four (4) bolts holding the F69 ATC to the crate. These bolts are located at the four bottom corners of the Main Base.

You will need a Fork Truck with a minimum of 8,000 lb. Capacity. The F69 ATC can be picked up from the pallet in two (2) different ways. See the following page for illustration of these procedures.

Type One

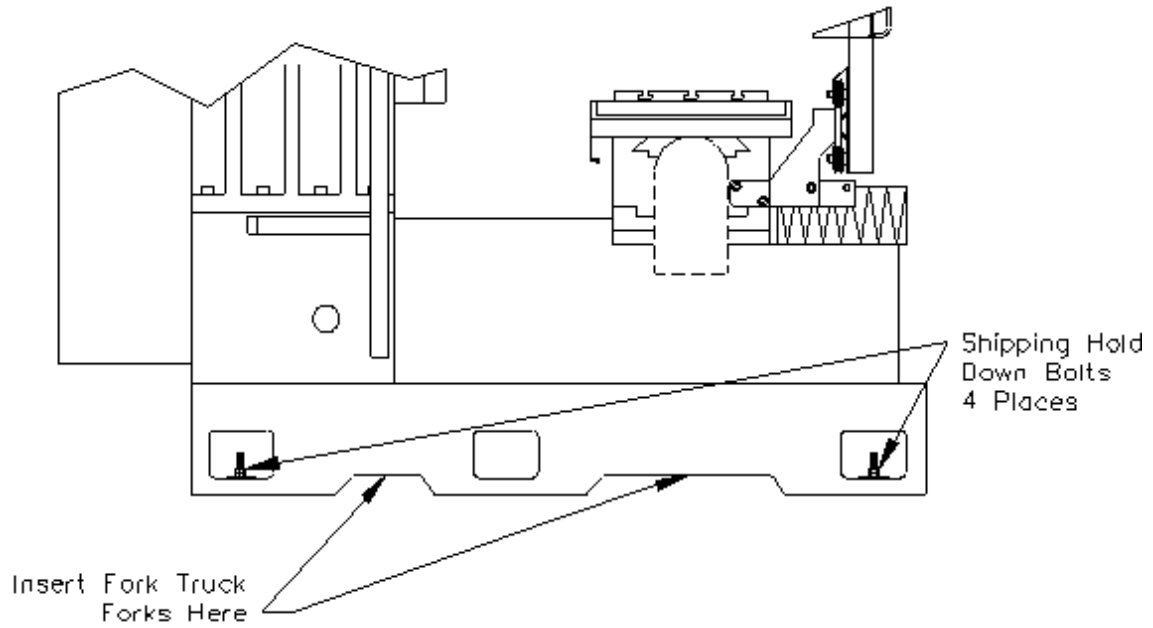

Be sure that the forks are at least Four inches through the opposite side of the casting.



This machine is extremely top heavy. Use extreme care whenever this machine is being used. Do not use quick or sharp movement.

Type Two

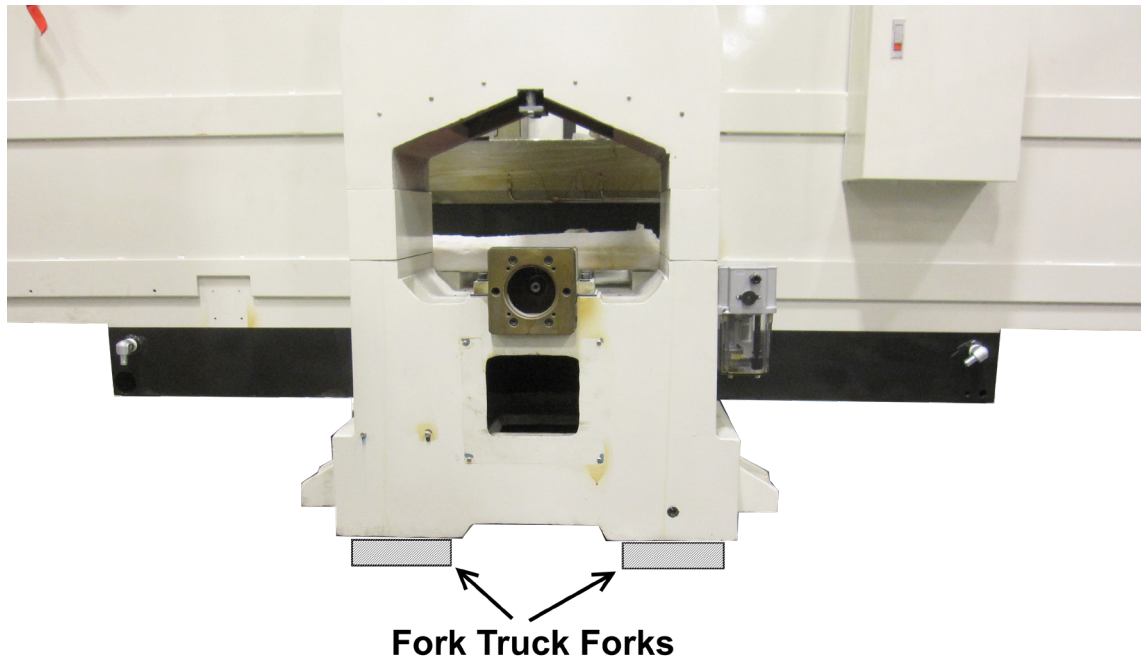

Remove the Toolbox, Parallels and optional equipment from the machine. Completely clean these articles along with the rest of the machine with solvent, rust inhibitor was applied at the time of shipment. Any of the rust inhibitor left on the machine will allow Cast Iron dust to build up and cause premature wear to the machine.

IMPORTANT

The ways under the table as well as the ways behind the Vertical gibs were sprayed with rust inhibitor as well. It is extremely important that these surfaces be cleaned thoroughly. Use a cleaner, such as WD-40 to clean the ways where the table and the spindle unit are not sitting. Move the table and spindle unit onto the area that has been cleaned and clean where they were sitting. Spray the ways with WD-40 and move the table and spindle unit over the sprayed area. You must do this several times to get all of the rust inhibitor off of the gib surfaces. If you do not the rust inhibitor will plug up the oiler holes and also cause shuddering when moving in small increments, such as handwheel.

Leveling and Alignment

Leveling the F69 ATC properly is very important if you are to use the F69 ATC to its full blue printing capabilities as well as maximizing the use of Rottler fixturing.

Use the following instructions to properly level the F69 ATC.

Six Hex head bolts, six jam nuts, and six purple leveling pads are provided with the machine for leveling. Refer to the following illustrations for leveling bolt locations. Screw the jam nuts all the way onto the bolts; insert the bolts at the base support points. Screw the bolts in until they are just protruding from the bottom of the base casting. Lower the machine onto the Leveling pads, making sure the bolts seat into the recessed area of the leveling pads.

Make sure there is equal pressure on each of the leveling bolts. Remove the protective rubber cover, located behind the table, from the Y-Axis (In/Out). Place the level on the Y-Axis ways, level the ways in both directions (Horizontal / In-Out) within .0005".

Check the level in both directions on the Table. If it does not match the alignment of the Y-Axis ways refer to the Maintenance Chapter of this manual for full alignment procedures.

Leveling Bolt Locations

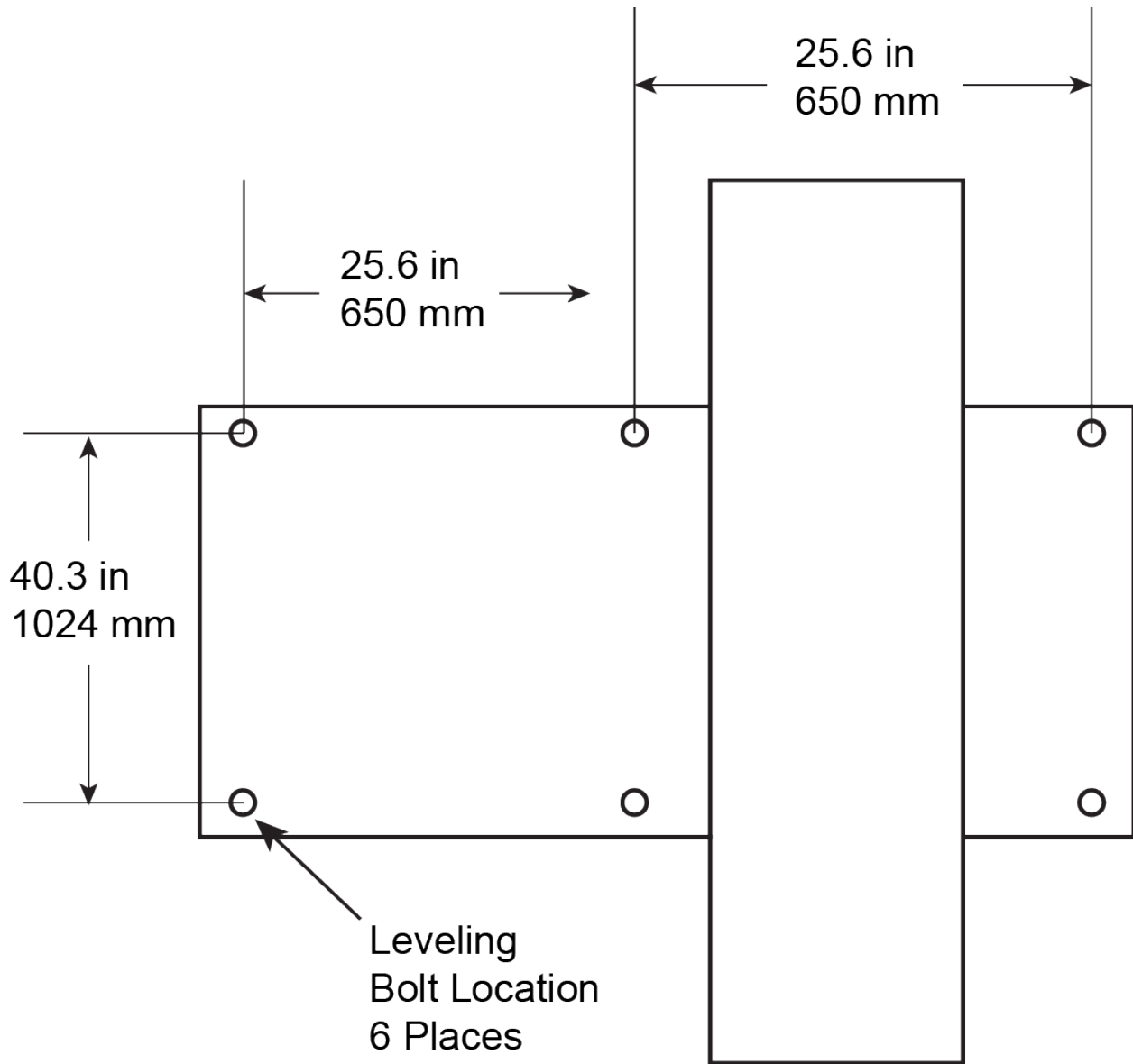

Air Supply

It is very important that the air source for the F69 ATC be moisture free. Water and oil in the air lines will result in early cylinder and valve failure as well as introducing moisture into the Inner spindle bearings. The factory recommends installing a water trap at the machine.

Attach a 100 PSI air source to the main air intake located on bottom of the Air Regulator Enclosure located on the back of machine next to the Electrical Enclosure.



Power Supply

This machine has the following power requirements:

- 208 to 240 VAC
- Three Phase
- 50 or 60 Hertz
- 50 amps

See illustration for correct connection of “measured” incoming power. Connect three phase wiring to the power terminals located in the main rear enclosure, located on the right rear of machine base. The connection terminals are located on the DIN rail. Connect high leg of 3 phase power to L3 blue terminal. Attach other 2 power lines to terminal blocks L1 and L2. Attach wire from the grounding rod to the ground block.

(This illustration is for reference only. Actual location of components may be different.)

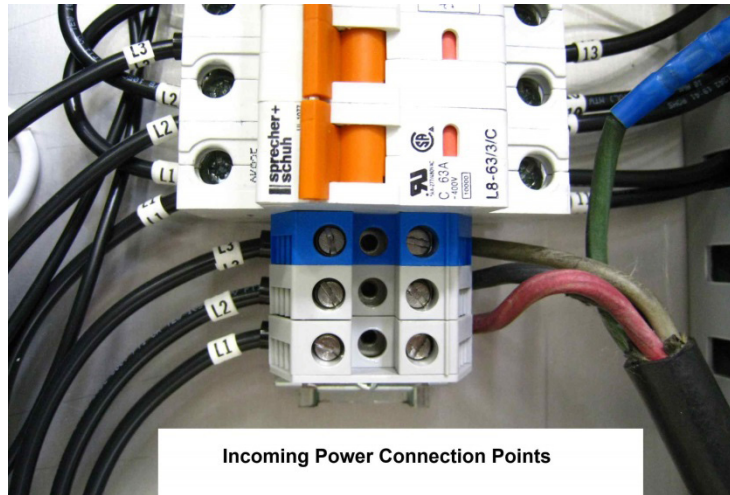

IMPORTANT

Electrically connect in accordance with national and local electrical codes.

Grounding

This machine must be connected to a good earth ground rod. A 6 foot, 1/2" diameter, 15 OHM, Copper grounding rod driven into the earth next to the machines is preferred. **Not providing a grounding rod could void factory warranty.**

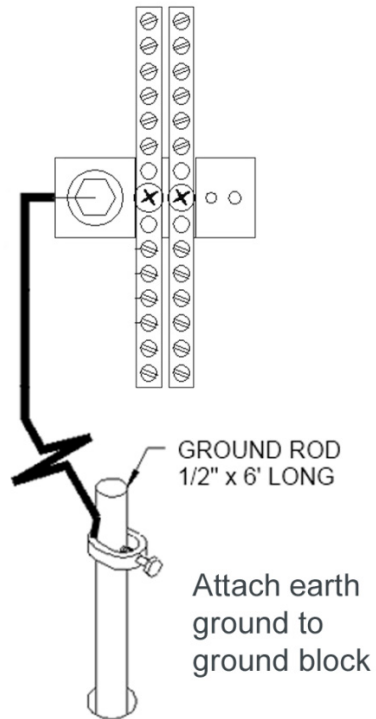
**IMPORTANT**

Electrically connect in accordance with national and local electrical codes.

Getting Started

Once power has been supplied to the machine measure the incoming voltage with a meter to verify proper voltages before turning the Main Power switch on. Failure to measure and record proper voltages to the machine could cause damage and will void factory warranty. Measure L1 to L2 and record on the installation report. Record L1 to ground and L2 to ground and record on the installation report.

Power Up

Turn the Main Power switch on. Allow a few minutes for the machine to fully boot up.

Note: The Rottler F69 ATC uses a touch screen for control and data transfer to the computer. Be careful not to touch the screen until the machine has fully booted up and a Rottler screen is showing. If the screen is touched prior to full boot –up it may activate a function or interfere with proper boot-up.

The first screen to appear is the Rottler Manufacturing Program Select screen. Press the ENTER button to start the Rottler software.



The next screen to appear is the Block Select screen. At this point, select any block from the top level and any mode from the lower level. Then press SELECT. This needs to be done to be able to move the machine in Handwheel mode.

The following Screen will appear.



Shipping Restraints

There are two main shipping restraints on the F69 ATC. A restraint under the spindle and a bar through the counter weight. The following is the procedure for removing these restraints.

IMPORTANT: Do not touch any of the rapid travel movements on the machine at this time.

Spindle Support

Once in the General Bore Mode (Set Zero Tab) press the VERTICAL .001 Handwheel button. Use the handwheel to move the spindle up until it clears the spindle support. Unbolt and remove the spindle support from the table.



Counter-Weight Bar and Bolt

Remove the two bolts securing the Counter-Weight Bar. Using the Vertical handwheel move the Spindle head up slowly until the Counter-Weight bar is free. Remove the bar and save for possible later use in shipping. The Bolt to the counter weight is no longer used.

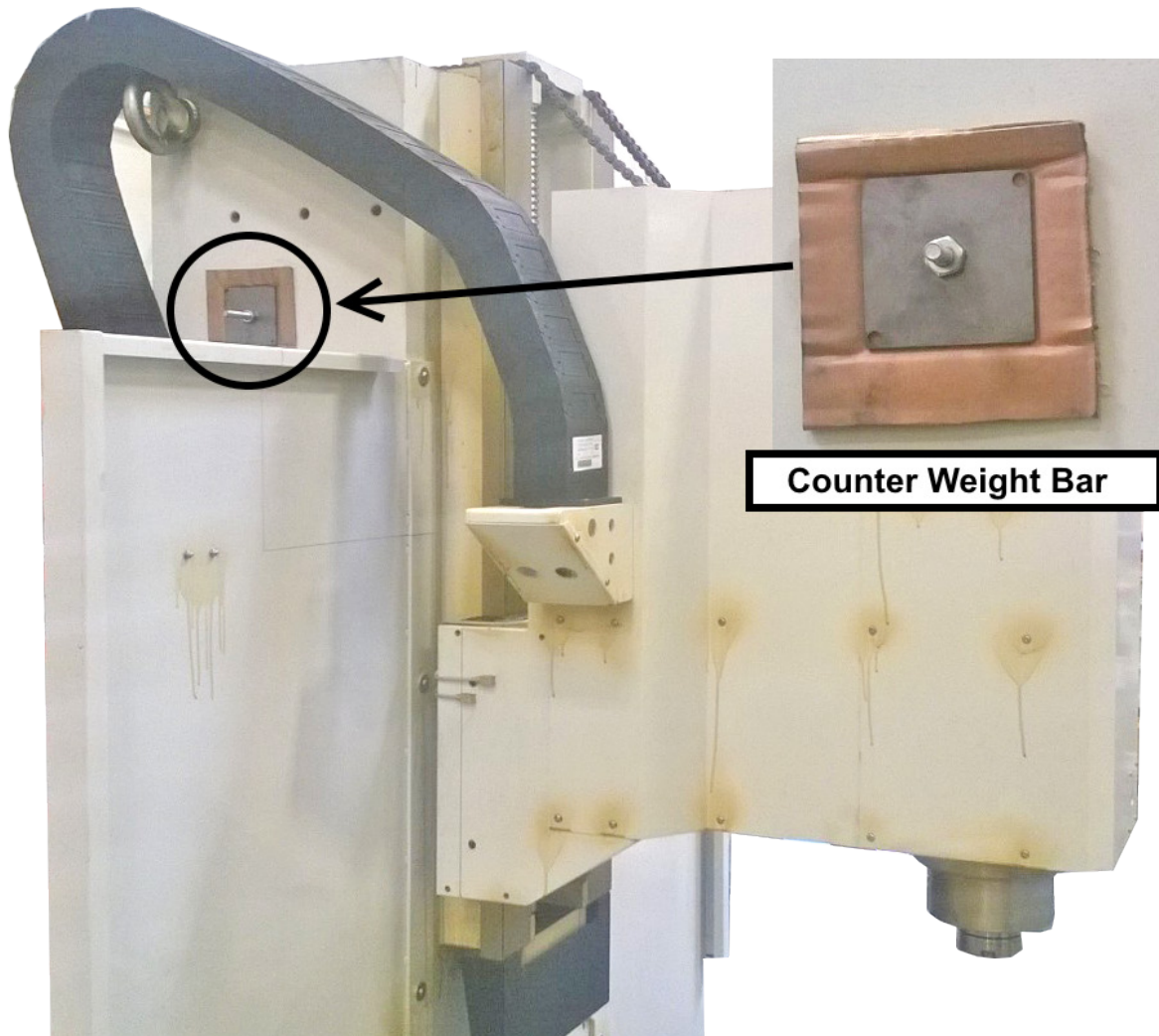

It is important that the operator of the F69 ATC read the Control Definitions chapter in this manual before proceeding any further.

Creating a Skype Account

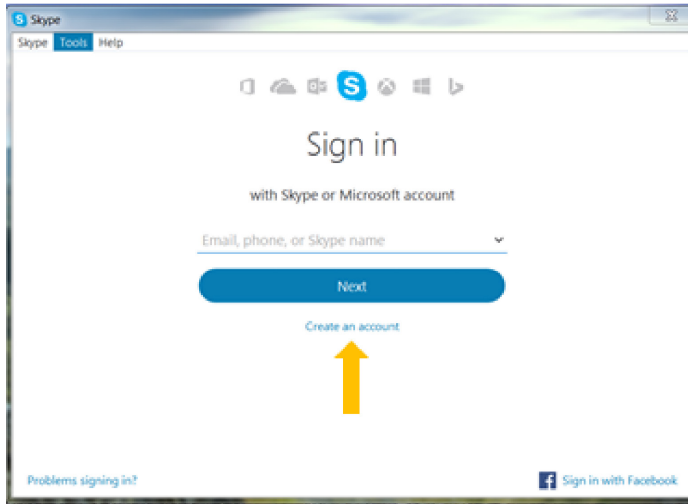

Click on create an account

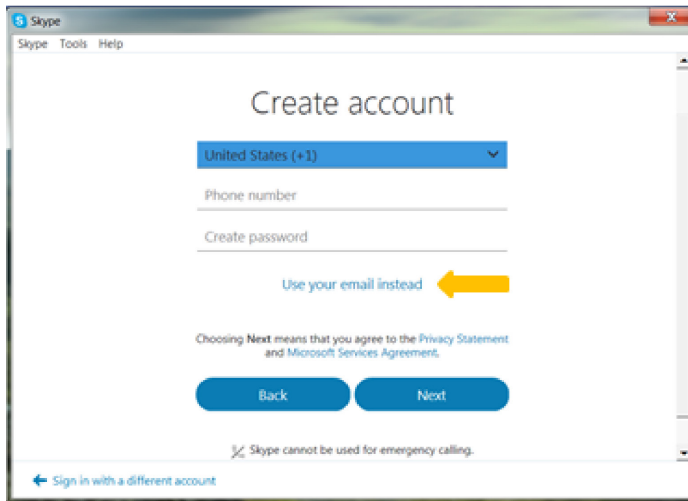

Click on: Use your email instead

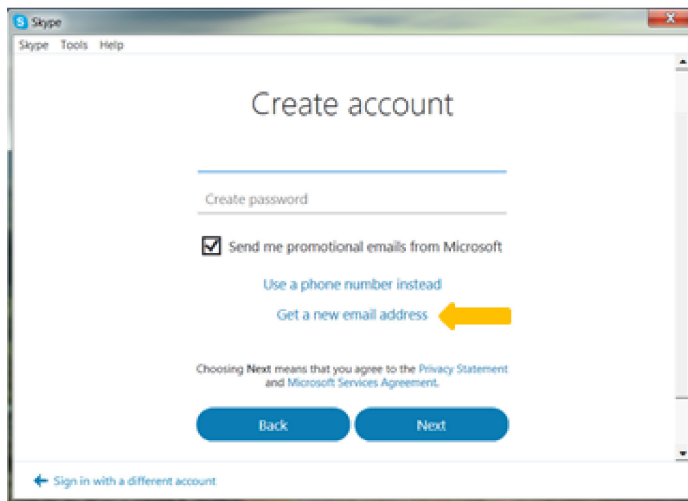

Click on: Get new email address

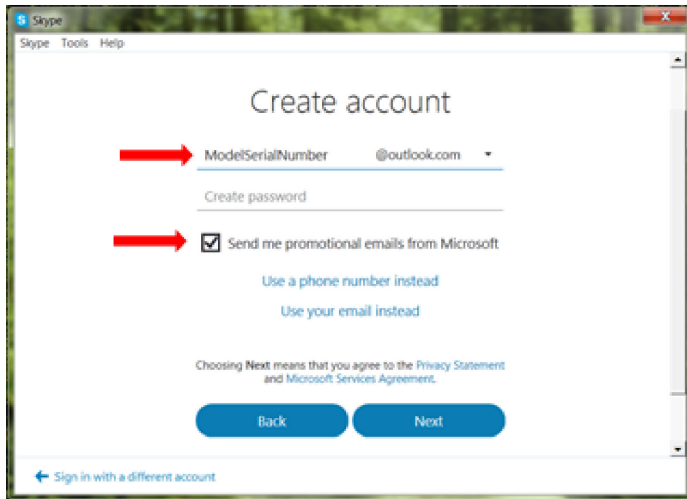

Name the email account using the Rottler machine Model and Serial number.

Ex: H85A111, EM69P001

Create a password that is easy to remember.

Uncheck the box to receive emails from Microsoft.

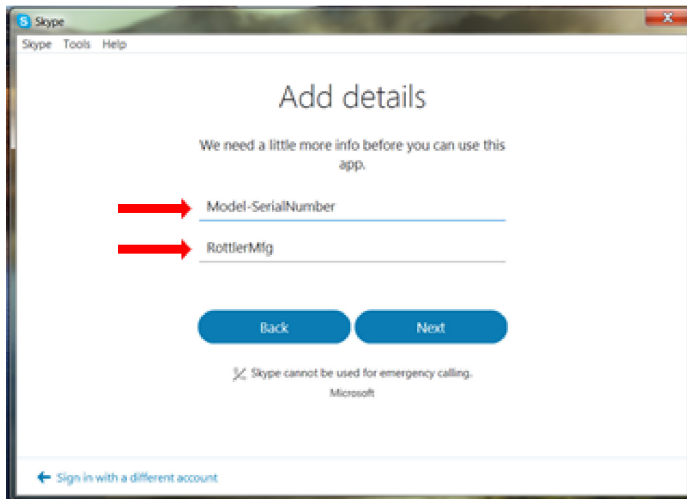

First Name: Model-Serial Number

Ex: H85A-111, EM69P-001

Last Name: RottlerMfg

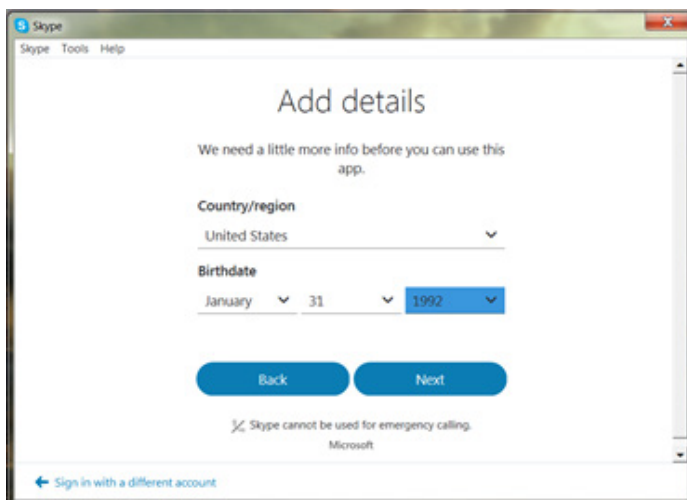

Select your Country/region

Birthday: Today's date, year 1992



Type the code exactly as it appears.

Click "Next"

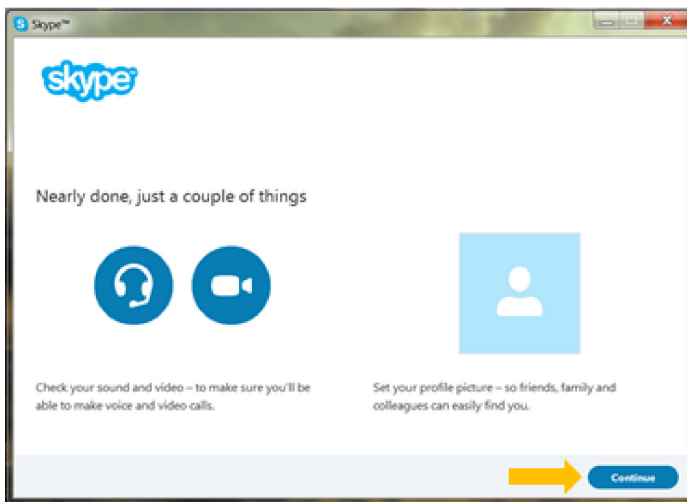

Click "Continue"

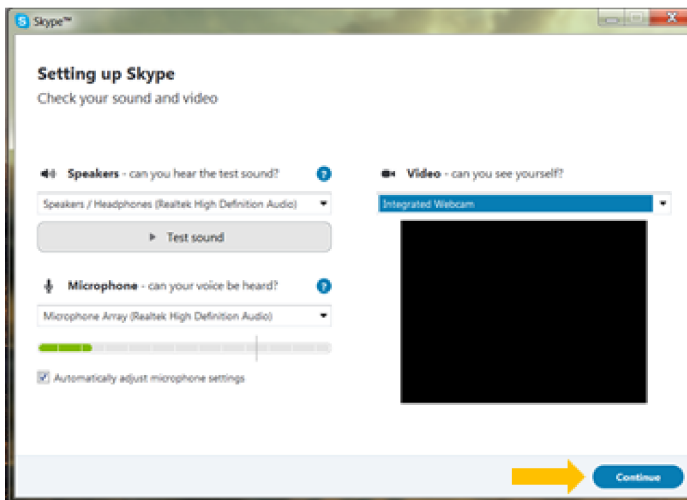

If your headset and/or web camera are hooked up you can verify that they are working here.

Otherwise, click "Continue"

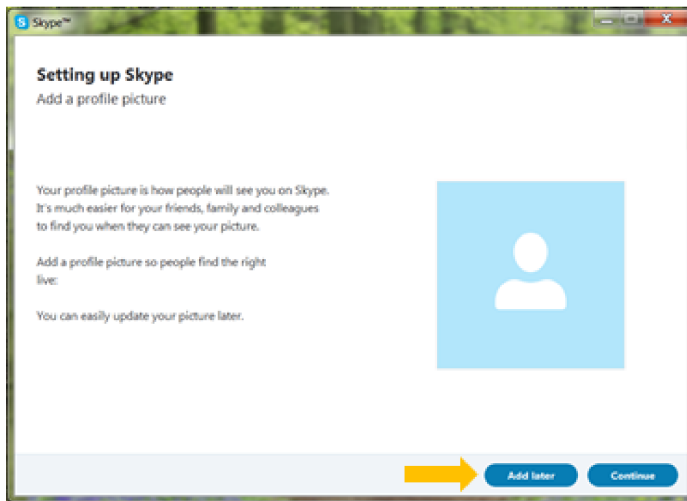

Click "Add later" to skip this part.

Your Skype account is set up and ready for use.

SAFETY

Contents

Safety Information	3-1
Safety Instructions for Machine Use	3-1
This machine is capable of causing severe bodily injury	3-1
Electrical Power.....	3-3
Machine Operator	3-5
Emergency Procedure	3-6
Computer and Controller System Safety	3-6
Electrical Safety Features Of Rottler DM Controlled Machines	3-7

Safety Information

For Your Own Safety Read This Instruction Manual Before Operating This Machine.

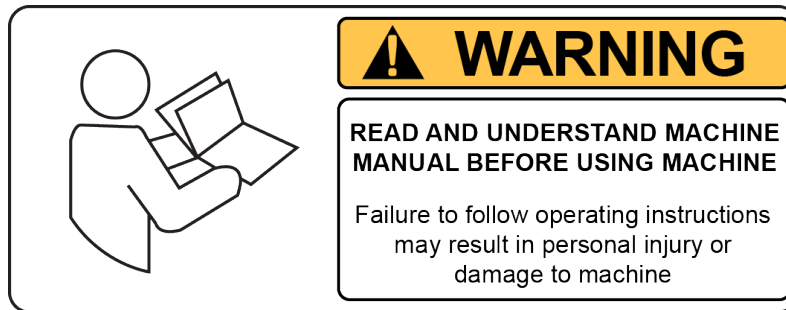

This is the safety alert symbol. It is used to alert you to potential personal injury hazards. Obey all safety messages that follow this symbol to avoid possible injury or death.



DANGER indicates an imminently hazardous situation which, if not avoided, will result in death or serious injury.



WARNING indicates a potentially hazardous situation which, if not avoided, could result in serious injury.



CAUTION indicates a potentially hazardous situation which, if not avoided, may result in minor or moderate injury.



CAUTION used without the safety alert symbol indicates a potentially hazardous situation which, if not avoided, may result in property damage.

Safety Instructions for Machine Use



This machine is capable of causing severe bodily injury

ONLY A QUALIFIED, EXPERIENCED OPERATOR SHOULD OPERATE THIS MACHINE. NEVER ALLOW UNSUPERVISED OR UNTRAINED PERSONNEL TO OPERATE THE MACHINE. Make sure any instructions you give in regards to machine operation are approved, correct, safe, and clearly understood. Untrained personnel present a hazard to themselves and the machine. Improper operation will void the warranty.

KEEP GUARDS IN PLACE and in proper working order. If equipped with doors, they must be in the closed position when the machine is in operation.



KEEP WORK AREA CLEAN. Cluttered areas and benches invite accidents.

KEEP CHILDREN AND VISITORS AWAY. All children and visitors should be kept a safe distance from work area.

WEAR THE PROPER APPAREL. DO NOT wear loose clothing, gloves, rings, bracelets, or other jewelry which may get caught in moving parts. Non-Slip foot wear is recommended. Wear protective hair covering to contain long hair.

ALWAYS USE SAFETY GLASSES. Also use face or dust mask if cutting operation is dusty. Everyday eye glasses only have impact resistant lenses, they are NOT safety glasses.



DO NOT OVER-REACH. Keep proper footing and balance at all times.

USE THE RECOMMENDED ACCESSORIES. Consult the manual for recommended accessories. The use of improper accessories may cause risk of injury.

CHECK DAMAGED PARTS. Before further use of the machine, a guard or other part that is damaged should be checked to determine that it will operate properly and perform its intended function. Check for alignment of moving parts, breakage of parts, mounting, and other conditions that may affect its operation. A guard or other part that is damaged should be properly repaired or replaced.

NEVER OPERATE A MACHINE WHEN TIRED, OR UNDER THE INFLUENCE OF DRUGS OR ALCOHOL. Full mental alertness is required at all times when running a machine.

IF AT ANY TIME YOU ARE EXPERIENCING DIFFICULTIES performing the intended operation, stop using the machine! Then contact our service department or ask a qualified expert how the operation should be performed.

DO NOT MODIFY OR ALTER THIS EQUIPMENT in any way. If modifications are deemed necessary, all such requests must be approved and/or handled by Rottler Manufacturing. Unauthorized modifications could cause injury and/or damage to machine and will void the warranty.

SAFETY DECALS SHOULD NEVER BE REMOVED. They are there to convey important safety information and warn of potential hazards.

ALL LOCAL SAFETY CODES AND REGULATIONS should be followed when installing this machine.

ONLY QUALIFIED PERSONAL should perform service on the electrical and control systems.

When boring the machine is capable of throwing metal chips over 10- feet from the cutting area. Always use the guards. Eye protection must be worn at all times by the operator and all other personnel in the area of the machine.



CAUTION No list of safety guidelines can be complete. Every piece of shop environment is different. Always consider safety first, as it applies to your individual working conditions. Use this and other machinery with caution and respect. Failure to follow guidelines could result in serious personal injury, damage to equipment or poor work results.

Electrical Power

THIS MACHINE IS AUTOMATICALLY CONTROLLED AND MAY START AT ANYTIME

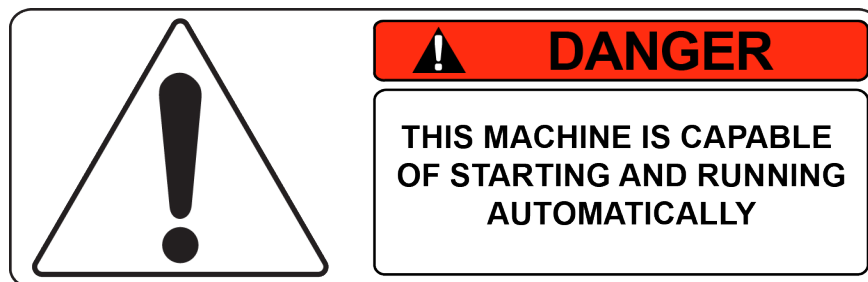

All electrical power should be removed from the machine before opening the rear electrical enclosure.

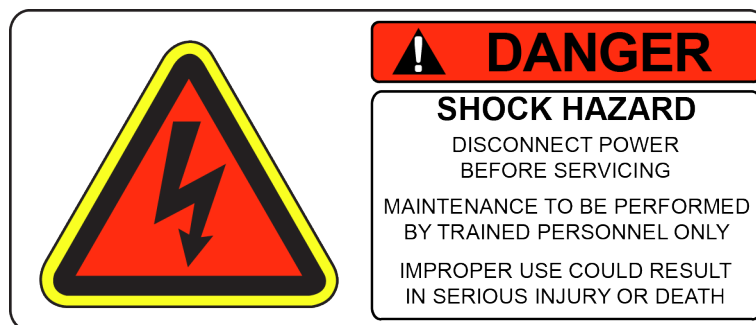

In the event of an electrical short, grounding reduces the risk of electric shock by providing a path of least resistance to disperse electric current.

Electrocution or a fire can result if the machine is not grounded correctly. Make sure the ground is connected in accordance with this manual. DO NOT operate the machine if it is not grounded.

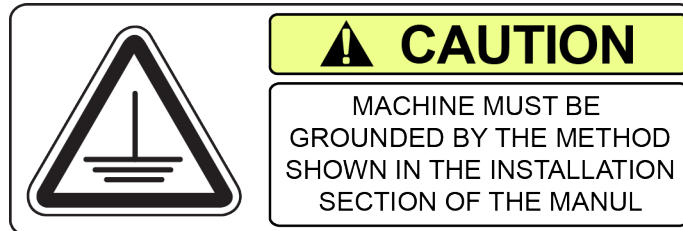

CAUTION No single list of electrical guidelines can be comprehensive for all shop environments. Operating this machinery may require additional electrical upgrades specific to your shop environment. It is your responsibility to make sure your electrical system comply with all local codes and ordinances.

WARNING This machine operates under computerized control and, as is all computerized equipment, and is susceptible to extraneous electrical impulses internally for externally produced. The machine may make moves out of the operator control at any time. The operator should work in and around the machine with caution at all times.

The operator and nearby personnel should be familiar with the location and operation of the Emergency Stop Button.

Make sure all electrical equipment has the proper overload protection. This machine should have **a fully isolated** power supply to prevent damage and uncontrolled movement of the machine. If this machine is on the same power lines that are running to other electrical equipment (grinders, welders, and other AC motors) electrical noise can be induced into this machines electrical system. Electrical noise can cause the controller to see false signals to move. Not supplying a fully isolated supply to the machine may void factory warranty. Refer to the Power supply section located in the Installation section for voltage and amperage requirements of this machine.

Machine Operator

The operator of this machine should be a skilled machinist craftsman who is well versed in the caution, care, and knowledge required to safely operate metal cutting tools.

If the operator is not a skilled machinist he/she must pay strict attention to the Operating Instructions outlined in this manual, and get instruction from a qualified machinist in both production and operation of this machine.

This machine has the following areas of exposed moving parts that you must train yourself to respect and stay away from when they are in motion:

Cutting Tool Area – Any operation involving hands in the cutter head area, such as inspection or alignment of the cutter head or tools, changing Centering Fingers, tool insertion, and removal, cutter head changes, and size checking etc. requires the machine to be in Neutral.



Machining – Eye protection must be worn during all operations of the machine. Hands must be kept completely away from the cutter head. All chip guards must be in position during machine operations.



CAUTION **Work Loading and Unloading** – Carefully develop handling methods of loading and unloading work pieces so that no injury can result if hoist equipment or lift connection should fail. Periodically check lift components for damage that may cause failure.

CAUTION **Machine Maintenance** – Any machine adjustment, maintenance or parts replacement absolutely requires a complete power disconnection from the machine.

Emergency Procedure:

Assuming one of the following has occurred: tool bit set completely off size, work piece or spindle base not clamped, spindle is not properly centered, and these mistakes will become obvious the minute the cut starts

PRESS THE EMERGENCY STOP BUTTON (on the front control panel) **IMMEDIATELY!**

Find out what the problem is; return the spindle to its up position without causing more damage. To restart the machine, turn the Emergency Stop Button CW until the button pops out

Be alert to quickly stop the machine in the event of a serious disruption of the boring process either at the top or bottom of the bores.

“REMEMBER” metal cutting tools have the speed and torque to severely injure any part of the human body exposed to them.

Computer and Controller System Safety:

The computer and controller are located in the main rear electrical enclosure. This unit is a full computer, running Windows 7 64 Bit operating system. Contact the factory if more information on the computer system is required.

IMPORTANT The computer in this machine has the ability to connect to the World Wide Web via Ethernet or Wireless using a USB wireless (Wi-Fi) adapter. Updating the Rottler software should **ONLY** be done when directed to do so by a Rottler service technician. Updating Rottler Software when not directed by Rottler personnel will result in a non-operational machine.

The machine should be hooked up to the Internet anytime it is on. The software on the machine will automatically connect to our server to send back useful information on machine status.

Any “IT” personnel should **ALWAYS** get approval from Rottler before doing **ANYTHING** on the computer.

DANGER This machine is capable of causing severe injury or death. Doing any of the following without Rottler’s direct consent may cause severe injury or death.

WARNING Do not attempt to install USB devices in the PCI ports. These ports have high voltage and any attempt to connect a USB device in these ports will result in destruction of that device. There is also the possibility of damage to the computer system of the machine.



IMPORTANT Downloading any program or changing any Rottler or Computer settings may cause the machine and/or software to become unstable. **DO NOT** install ANY screen saver, Anti-Virus, Spyware or any type of Security software on the computer. This could create a hazardous environment for the operator and personnel around the machine. Performing any of the above will also result in the machine warranty being NULL and VOID.

IMPORTANT **DO NOT** connect any type of external hardware to the computer via USB or any other means. Do not install any type of Device Driver. This could create a hazardous environment for the operator and personnel around the machine. Performing any of the above will also result in the machine warranty being NULL and VOID.

Electrical Safety Features Of Rottler DM Controlled Machines

All Rottler machines that use the DM operational control system are designed to comply with all applicable safety standards. This includes but is not limited to the following systems:
Thermal sensors in all motors and motor controls.

1. Current sensors in all motor control panels.
2. Electrical breakers to prevent voltage surges and spikes from reaching electrical system.
3. Electrical lockout on main electrical enclosure.
4. E-Stop that shuts down all operational systems in an event of an emergency.

All thermal and current limits for motors and motor controls are preset at the factory. In the event that any of those parameters are exceeded during operation of the machine, the machine control system will shut down the machine and a warning of the specific fault will appear on the control screen.

CONTROL DEFINITIONS

Contents

Control Definitions	4-1
Computer and Controller System Safety for DM Controlled Machines.....	4-1
Master Power On/Off Switch	4-2
Initialization Screen.....	4-3
General Information	4-3
HOME.....	4-3
FIXTURE SELECT	4-3
TABLE OF TOOLS.....	4-4
PROGRAM SELECT.....	4-4
NEW	4-4
OPTIONS	4-4
DELETE:	4-4
MODE SELECT.....	4-4
SELECT	4-4
NEW	4-4
OPTIONS	4-4
STANDARD SETUP.....	4-4
DELETE	4-5
Mode Select.....	4-5
New.....	4-6
Std (Standard) Setup	4-8
Options	4-8
Delete	4-9
Cylinder Bore, General Bore 3 Axis	4-9
Set Zero Tab.....	4-9
Actual Position	4-9
Velocity Override.....	4-9
Zeroing Buttons	4-9

SETTING HORIZONTAL AND IN/OUT ORIGIN.....	4-10
SETTING SPINDLE ORIGIN	4-10
SETTING 4TH AXIS	4-10
SETTING THE VERTICAL ORIGIN- IMPORTANT SECTION	4-11
Handwheel Buttons	4-11
Spindle Start.....	4-11
CW and CCW	4-11
Jog Buttons	4-12
Move to	4-12
Move To Zeros	4-12
CW and CCW Index.....	4-12
Probe Auto Center	4-12
Vertical Stops Tab.....	4-13
Horizontal Offset for Homing.....	4-14
Left and Right Locations Tab	4-15
Cylinder Bore – Bore Locations	4-15
Blueprint	4-15
Move Buttons	4-15
Bore Buttons	4-16
Indicated	4-16
Set Buttons.....	4-16
Copy Values.....	4-16
Difference	4-16
Bore Left and Right.....	4-16
Probing	4-17
Probe Buttons	4-17
Probe Left or Right	4-17
Probed Diameter	4-17
Lifter Bore	4-18
Cylinder Bore 4 Axis.....	4-18
Jog Controls	4-18
4Th-	4-18
4Th+.....	4-18
4th Axis Degree and Move	4-18
4th axis Brake.....	4-19
Light Clamp	4-19
Full Clamp.....	4-19
Retract.....	4-19

ATC Specifications	4-19
Table Of Tools	4-20
Table Of Tools General Information	4-20
Accessing Table Of Tools.....	4-21
Tool Number versus TC Pocket.....	4-22
Add Tool.....	4-22
Remove Tool.....	4-23
Set Active Tool	4-23
Setting Tool Offsets.....	4-24
Z Location from Zero	4-25
Z Touch Off Height.....	4-25
Add Tool Radius?.....	4-25
Applying Table of Tools to Rottler Programs	4-26
Fixture Select	4-26

Control Definitions

The purpose of this chapter is to define the function of the buttons throughout the various screens. Certain button functions may not make sense right away in this chapter. As the operator reads through the Operating Instructions chapter of this manual, the function of these buttons will become clear.

Computer and Controller System Safety for DM Controlled Machines

The computer and controller are located in the main rear electrical enclosure. This unit is a full computer, running Windows 7 64 Bit operating system. Contact the factory if more information on the computer system is required.

IMPORTANT The computer in this machine has the ability to connect to the World Wide Web via Ethernet or Wireless using a USB wireless (Wi-Fi) adapter. Updating the Rottler software should **ONLY** be done when directed to do so by a Rottler service technician. Updating Rottler Software when not directed by Rottler personnel could result in a non-operational machine.

It is recommended that the machine be hooked up to the Internet anytime it is on. The software on the machine will automatically connect to our server to send back useful information on machine status. It will also record performance parameters that will be used to evaluate any occurrence of a malfunction.

The Auto Update for the Windows Firewall (Security) and Windows Defender (Anti-Virus) is turned on. The computer will automatically download the updates and then install them when the computer is shut down every Friday night.

Any "IT" personnel should **ALWAYS** get approval from Rottler before doing **ANYTHING** on the computer.

WARNING Downloading **ANY** program from the Internet or by other means when not directed by Rottler is prohibited and will result in the machine warranty being **NULL and VOID**.

WARNING Downloading any program or changing any Rottler or Computer settings may cause the machine and/or software to become unstable. **DO NOT** install **ANY** screen saver, Anti-Virus, Spyware or any type of Security software on the computer. This could create a hazardous environment for the operator and personnel around the machine. Performing any of the above will also result in the machine warranty being **NULL and VOID**.

Master Power On/Off Switch

This switch is located on the main electrical control enclosure on the right hand side of the machine. The switch must be in the off position before opening the rear enclosure door.

When first applying power to the machine the computer will need to boot up. Be patient, it will take several minutes to complete booting. The Rottler program will not automatically start. Double tap the Rottler_WPF icon on the screen to start Rottler.

When turning the main power to the machine off there is a specific procedure to follow so as not to damage the computer. The computer must shut down its internal systems before main power is removed from it.

Press the "Start" button in the left-hand side of the Start Bar. This will bring up the "Start Menu". Press the "Shutdown" line at the bottom of the Start Menu. This will bring up a Pop Up menu, make sure that "shut down computer" is selected and press "OK".

This will shut down the computer. It is now OK to turn Main Power off to the machine.

Initialization Screen

When the F69ATC is powered up the Rottler program will not automatically start. It may take several minutes for the computer to power. Start the Rottler program by double tapping the Rottler_WPF icon on the desktop. Once the program is started, the Rottler Program Select will appear.

NOTE: Do not push any buttons or icons on the screen before the Rottler program starts or an error may be caused on the computer.



General Information

The Rottler software operates on a Block Model format. You select or create the block you are working with. Then select or create an operation to be performed on that block.

HOME

Pressing this button will cause the machine to move all axis to their home (Machine Origin) position. The vertical will home first to be sure it is clear to move the other axis. The machine **MUST** be homed after it is turned on. This is how the machine gets its reference points to operate.

FIXTURE SELECT

Fixture Select allows end user to use several different part origins for many different blocks. This is used more for advanced level programming. It essentially allow user to store origins in one central place eliminating the need zero out IN/OUT and HORIZONTAL locations.

TABLE OF TOOLS

Similar to Fixture Select this is where the end user will store all of the heights of the various tools used for programming. In the Table of Tools you can define the cutter name, diameter, and most importantly the height offset. It is important to note that when using the table of tools it is unnecessary in most cases to zero out the vertical axis. Using the table of tools defines your vertical information.

PROGRAM SELECT

Under the Program Select section you will be building a library of different blocks. Within each of the blocks that are created there will be all of the operations that pertain to the defined block.

NEW

Click on this button to begin the process of defining a new block which will include the name of the block, how many cylinders, and whether it is an inline or v-block.

OPTIONS

By highlighting a block that has already been defined you can then click on the options button and edit the configuration of the block.

DELETE:

Highlight the block that you would like to delete then simply click on the delete button to eliminate the block.

MODE SELECT

Under mode select on the right side of the screen there are several options to choose from including SELECT, NEW, OPTIONS, STD SETUP, and DELETE.

SELECT

Under Mode Select on the right side of the screen after you have defined one or more new modes they will appear in a list in the order in which they were select. For example lets say you are working on the sbc block and you want to get into the bore mode. Simply highlight bore followed by clicking on Select.

NEW

Once block is selected click on the New button which will open a box that contains all the modes in which you can select to do various operations to the block such as BORE CYLINDER, MILL CYCLE, LIFTER BORE ect. As you select a mode you will see a list building to the right side listing the various operations that are associated with the block.

OPTIONS

The Options button located under mode select allows user to select a box allowing positive horizontal values to be entered in certain modes such as boring mode. By default the software assumes that you will be working form the right cylinder to the left so everything in this case would have negative values. There are however certain occasions in which positive values will be necessary. This option allows for this condition.

STANDARD SETUP

By clicking on standard setup this will apply every machining operation to the block that is active. If you already have a block set up with modes clicking on this will replace all your preexisting modes.

DELETE

To delete any mode from any active block, simply highlight the mode and click delete.

New

Click on New under program select to define a block. Input your block name, number of cylinders and the type of block

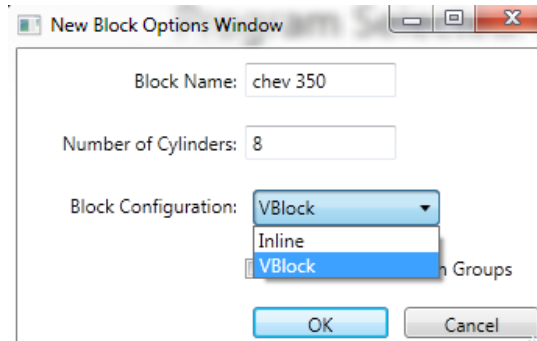

Pressing OK will result in the Block Model being inserted into the left hand side of the screen.

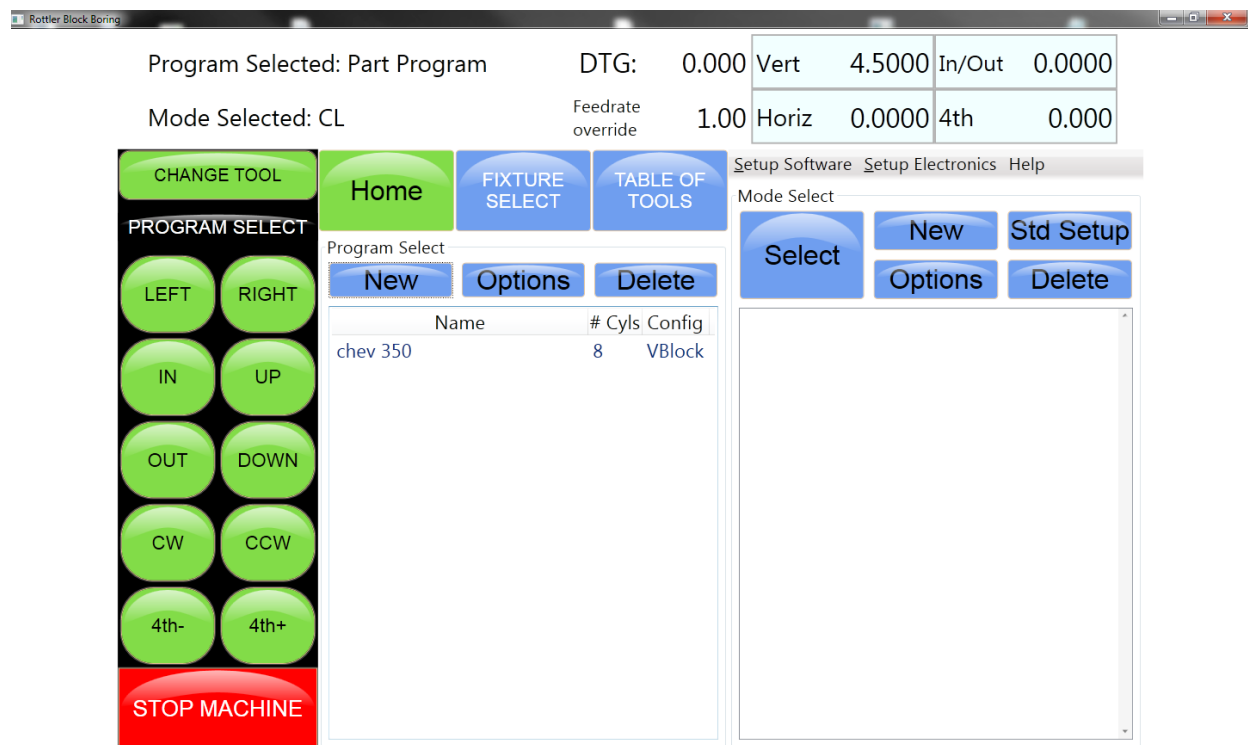

Mode Select

This is the right section of the screen. This is where you create or select operations to be performed on the selected Block. This area will be blank when you first create a block.

You can create only certain modes you will use on a block or use a standard set up that inserts all modes available. You can also create a new mode and rename if for a specific use.

New

Pressing the New button will bring up a dialog box with Rottler standard operations.

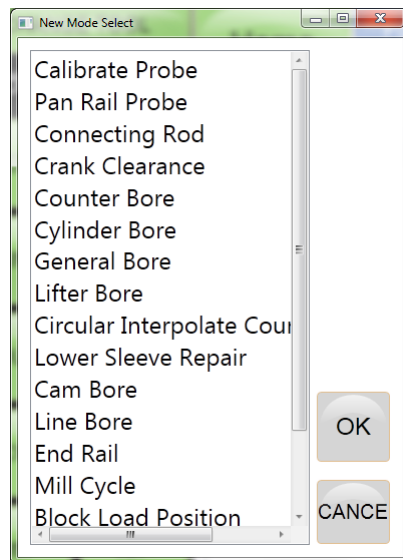
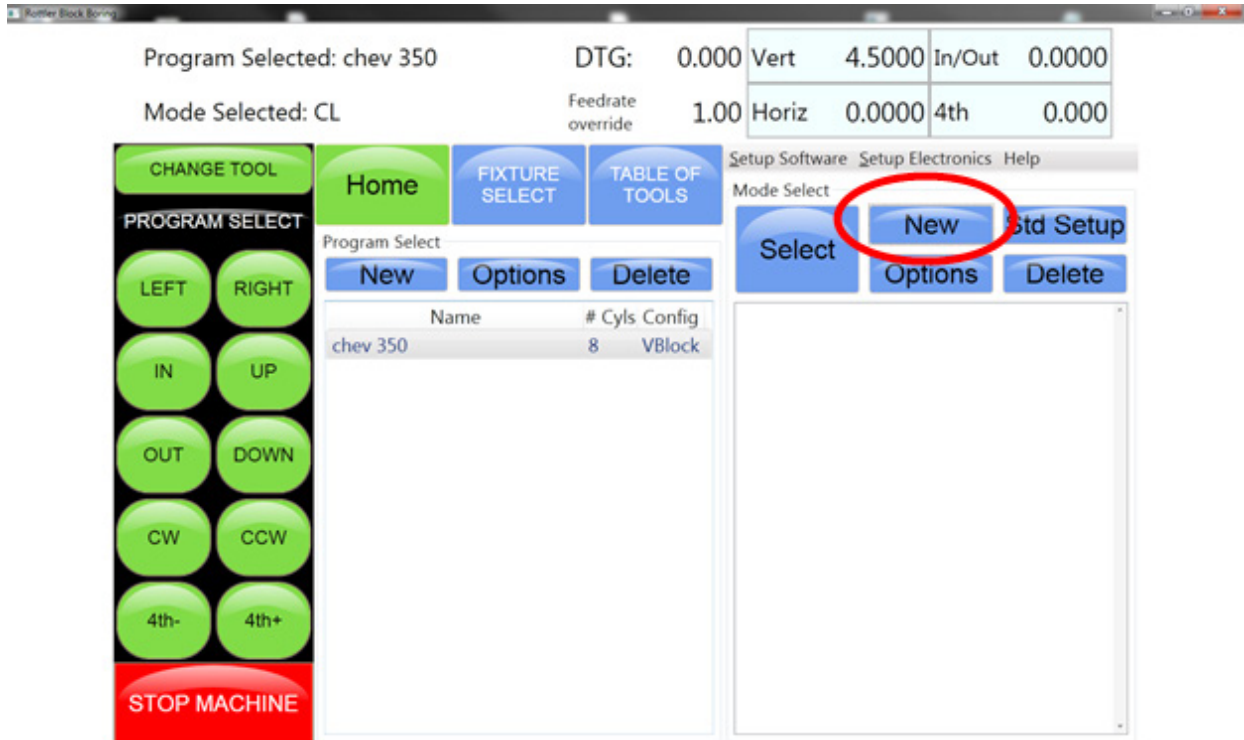

Select the operation you want to create and then press OK. The example below places a Cylinder Bore operation under the Cylinder bore mode in the right hand section.

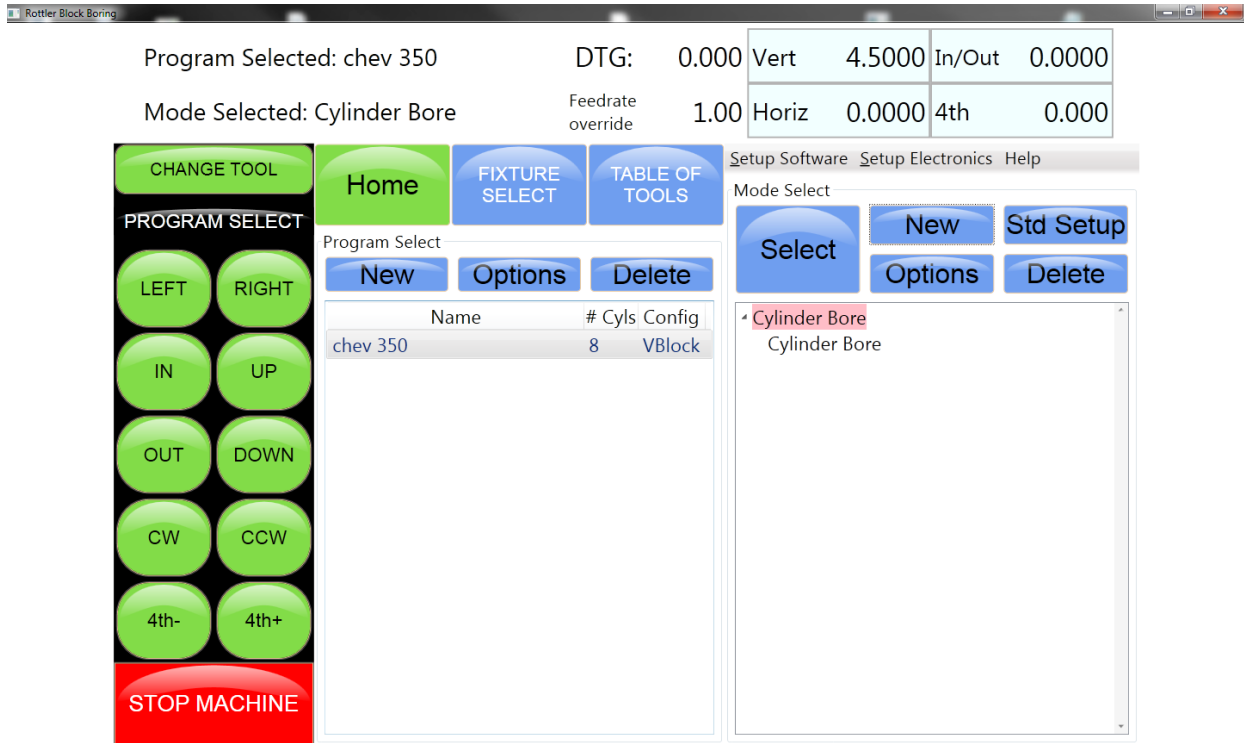

To enter General Bore mode highlight it and then press Select. This will take you to the operation screens that will be described later.

Std (Standard) Setup

Pressing this button will insert all the Rottler operations into the right hand section automatically.

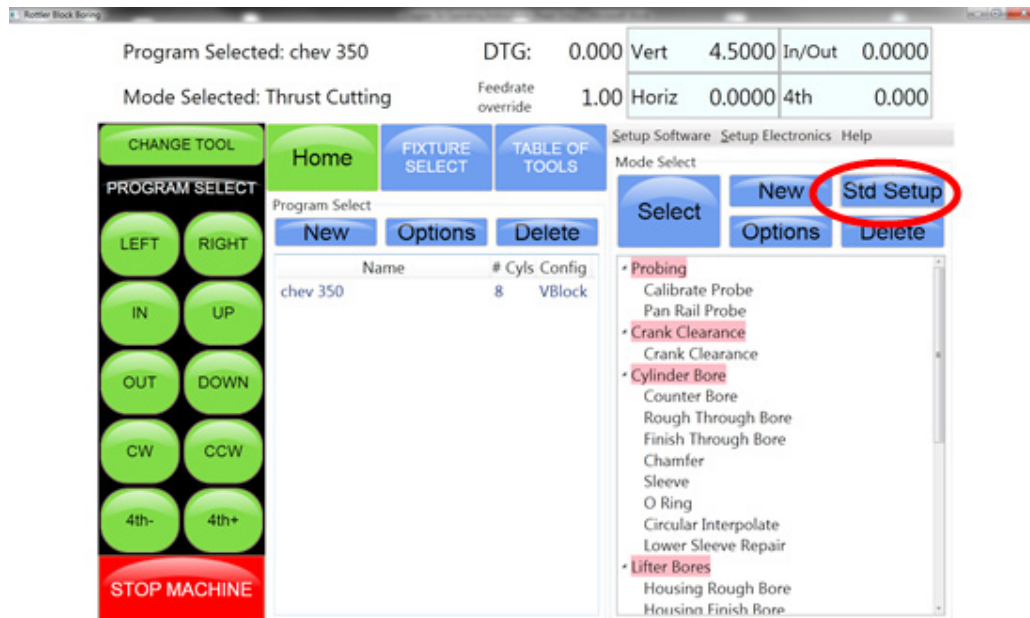

Use the slide bar on the right hand side to scroll through all the operations.

Options

Press this button to bring up a dialog box to allow positive numbers to be entered in the horizontal stops. In most cases programmers will pick up on the dowel pin or the first cylinder on the right and work to the left of the block using all negative horizontal values. However, not everyone will program the same way. There are occasions in which an end user may want to program from the left to right in which the numbers in this case will all be positive. There may also be cases where when a block is rotated from one bank to the other the first cylinder to the right maybe be shifted in a positive direction relative to the first cylinder on the opposite bank. In this case horizontal values will be both positive and negative.

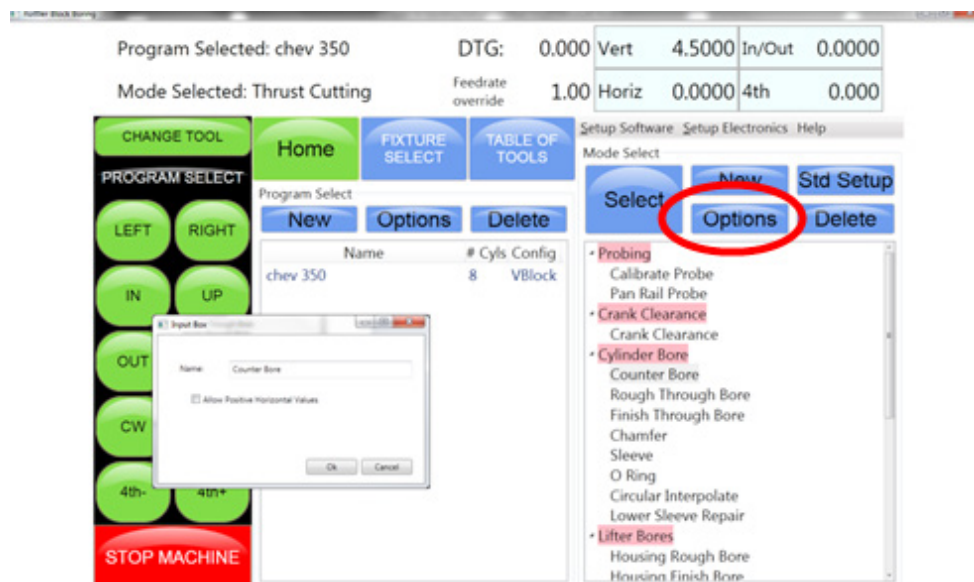

Delete

This will delete the selected Mode. It will ask you if you want this mode deleted before deleting it.

NOTE: Once the control definition for a particular button has been discussed it will not be repeated in the different modes of operation. Only new buttons or buttons with a different function will be discussed in different modes.

For these descriptions the Tool# and Probe # are not being used. They will be described later in this chapter.

Cylinder Bore, General Bore 3 Axis

Each buttons function will be described in this section. In the different MODES, the same buttons will not be described again.

Set Zero Tab

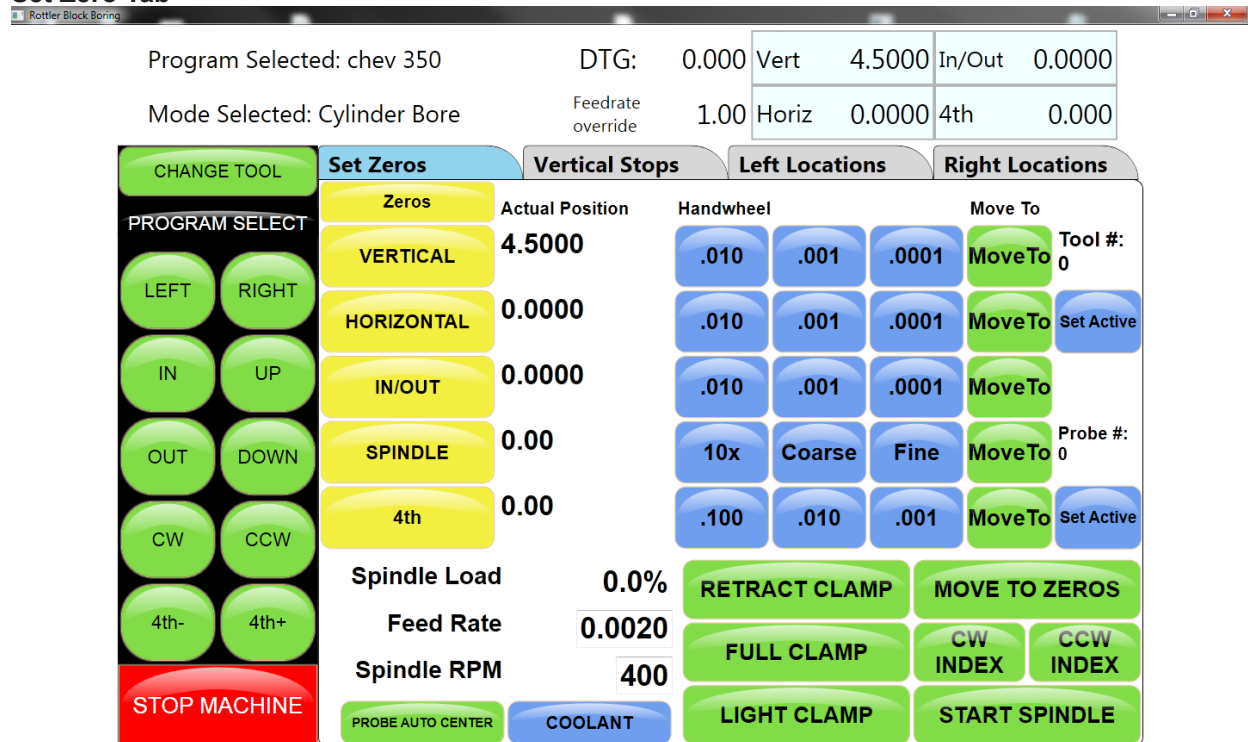

Actual Position

These are a numerical display showing the actual distance the axis are away from where they have been zeroed.

Velocity Override

The Velocity override is displayed in the upper left of the Actual Position display. The default is 100% of the programmed Feed Rate. When operating... turning the handwheel Counter Clockwise will override the axis rapid travel and feed rate 100 and 0% when in an automatic cycle.

Zeroing Buttons

(IMPORTANT SECTION. PLEASE READ AND UNDERSTAND BEFORE MOVING ON TO ANOTHER SECTION OF THE MANUAL ESPECIALLY HOW THE TOOL OFFSETS ARE RELATED TO THE VERTICAL ZEROING BUTTON.)

Zeroing buttons include Vertical, Horizontal, IN/OUT, Spindle, and the 4th axis. The ZEROS button that you see above the VERTICAL button stores your offset values. Without zeroing anything if you click on the ZEROS button you will see that the values for X,Y,Z,A, and S will read zero as you see in the dialog box below. These values are zeros by default when starting a brand new block.

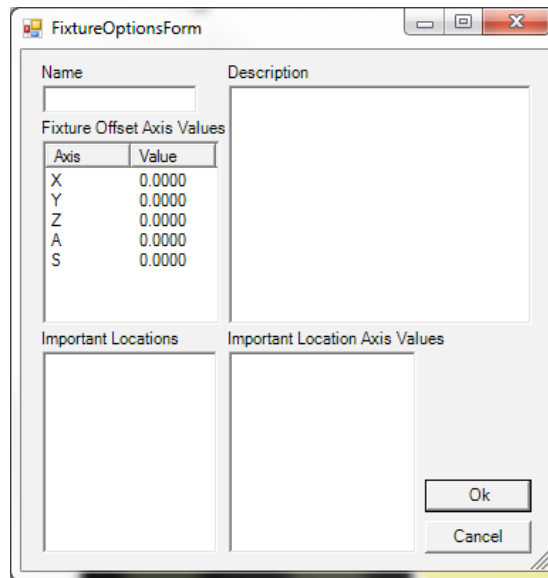

SETTING HORIZONTAL AND IN/OUT ORIGIN

To better understand how zeroing works let use an example. We have a 350 Chevy block loaded on a auto 4th axis unit. We will use cylinder 1 on the right side of the block on the left bank as our point of reference or origin. Eyeball the probe in the center of the cylinder and hit probe auto center to locate the center of the cylinder. Once the probe has finished the probing routine and found center simply click on the yellow HORIZONTAL and IN/OUT button. It will ask you if you are sure you want to zero out that axis. Select yes. You should then see that the digital read out(DRO) reads 0.000 for both the HORIZONTAL and IN/OUT locations. If you click on the ZEROS button now you will see that there are now values loaded in the X and Y. These values reflect the distance from the limit switches to the origin (center of cylinder in this case).

SETTING SPINDLE ORIGIN

When creating a program in boring mode in particular the other axis that you must zero is the spindle axis. The most effective way to handle this is to have the boring tool loaded in the spindle and with your hand physically move the spindle such that the cutting cartridge is facing the right(X positive direction) or what would otherwise be considered zero degrees. After physically moving spindle to zero degrees the DRO will have some arbitrary number in it. Click on the yellow SPINDLE button to zero out the spindle in this mode. This is important because at the end of a boring cycle the spindle will position itself at zero degrees then move away from the cylinder wall approximately .020" in the -X direction. Zeroing the spindle for a mill cycle is unnecessary.

SETTING 4TH AXIS

It will be unnecessary to have to zero the 4th axis. By homing the machine upon first starting the software the 4th axis always knows where it is the minute it hits the limit switch.

SETTING THE VERTICAL ORIGIN- IMPORTANT SECTION. PLEASE READ AND UNDERSTAND

When using the F69ATC 95% of time you will never have to zero out the vertical origin using the yellow

Vertical button. The vertical origin will simply be defined in the table of tools when setting up your tools. The table of tools which is addressed in section 2-21 stores all of the tool height offsets based off a known location. Usually you will set the tools up so that the origin or Z zero is in the middle of the main(not always however. This is purely personal preference and you can certainly set you Vertical anywhere this is simply a place to start and to learn how the software works together). To get to the middle of the main you can touch off the flat of the tailstock and subtract approximately 3.5" from that value(This is thoroughly discussed in section 2-21). There are a few circumstances in which you will use both tool height offsets and the Vertical zeroing button. Especially, when first beginning the ATC simply leave this button alone. When you click on the ZEROS button everything except the X,Y and SPINDLE(when boring) should have zeros loaded in each of these fields. There are a few occasions in which the Vertical button will be used but this will be covered in a later section.

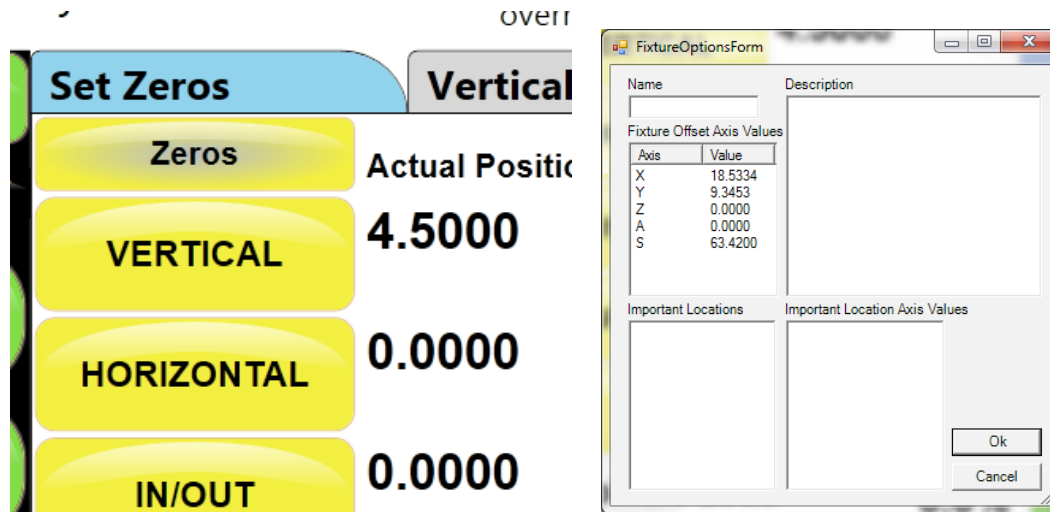

Handwheel Buttons

These buttons will activate their associated axis for use with the handwheel. The left button of each axis will move the machine in .010" per detent, the middle button .010" per detent and the right .0001" per detent of the handwheel. Pressing any of the axis Jog buttons will disengage the handwheel.

Spindle Start

This button will start the spindle at the RPM that is specified on the Auto Bore Cycle tab. Once the button has been pressed and the spindle is running the button will turn red and read Spindle Stop. Pressing the button again will stop the spindle and cause the button to go back to green.

CW and CCW

These buttons will cause the spindle to rotate slowly CW or CCW direction. The spindle will continue to rotate as long as the button is pressed. The speed at which the spindle will rotate is set in the Machine Parameters and should not be changed unless instructed to do so by the factory.

Jog Buttons

The green jog buttons (LEFT, RIGHT, IN, OUT, UP, DOWN, CW, CCW, AND (-+)4th) control the rapid travel of the Vertical, Horizontal and In/Out axis. Pressing these buttons will allow you to move the machine through all ranges of its travel. If the spindle is turned on these buttons become feed buttons and the machine will feed in whatever direction you have pressed. The rate at which the machine will feed is determined by the value set in the Auto Bore Cycle tab. When in rapid travel, these buttons are momentary contact and you will have to keep them pressed to keep the machine moving. When the spindle is on, they are latching buttons and once they are pressed the travel will continue until they are pressed again.

Move to

Pressing these buttons will bring up a dialog box for the associated axis. Enter a value that you want the axis to move to and press ENTER. That axis will then move to that position. You can do multiple "Move To" at the same time. One after another.

Move To Zeros

Pressing this button will cause the vertical to move the zero position first. The in/out and horizontal will move after the vertical has moved to zeros.

CW and CCW Index

Pressing either of these buttons will cause the spindle to rotate to the index position. Index position is with the tool to the right as you are facing the machine.

Probe Auto Center

The Probe is an option on the F69ATC machine. When clicking on the auto probe button you will see the box appear. Notice the blue highlighted section labeled ProbingRoutine. There are actually many different probing routines but by default the machine will probe an Inside Diameter. Click on the drop down arrow to see other options. If you simply eyeball the probe in the center of the cylinder then hit the GO button the machine will automatically find 4 points then center the probe about the 4 points. You will then zero out your Horizontal and IN/OUT if you wish.

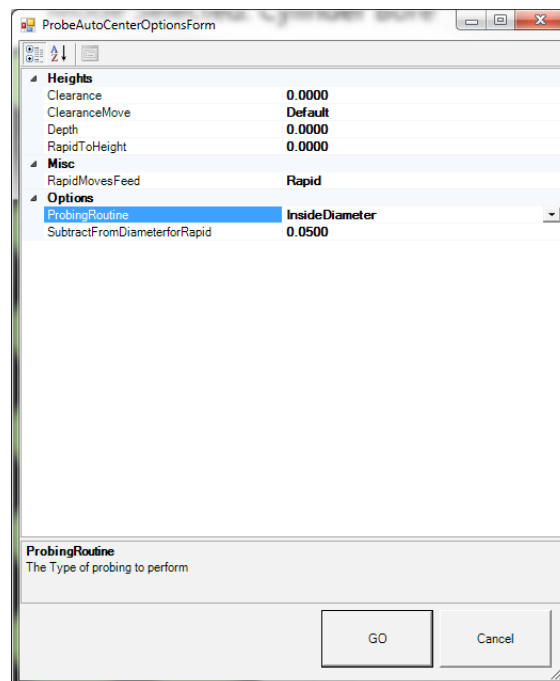

Vertical Stops Tab

This screen is used to set the Vertical stops the machine will use to bore a cylinder. There are four Vertical stops used on this screen plus two optional Lower Clearance stops.

If the machine is equipped with a probe there are two (2) additional stops, Probe Clearance and Probe Height.

The function of the Vertical stops will be defined in the Operating Instructions chapter in this manual.

To enter any of the Vertical Stops press the Data box next to the Vertical stop you want to enter. A pop-up menu will appear. Press the desired numerical value and then press ENTER. The numerical data will then appear in the data box. You can also move the Vertical physically to the location you want the stop to be at and press the "SET" button next to the Data Box. This will take the current position from the Digital read out and insert it into the associated Data Box.

The screenshot displays the control interface for a Rottler Block Boring machine. At the top, it shows the selected program 'chev 350' and mode 'Cylinder Bore'. A data table indicates current settings: DTG at 0.000, Feedrate override at 1.00, Vertical stop at 4.5000, In/Out at 0.0000, Horizontal stop at 0.0000, and 4th stop at 0.000.

The main interface is divided into several sections:

- Vertical Stops Tab:** The active tab, showing 'BORE PROFILE' settings:
 - Block Clearance: 0.0000 [SET]
 - Centering Height: 0.0000 [SET]
 - Start Boring Height: 0.0000 [SET]
 - Bottom of Bore: 1.0000 [SET]
- PROBE OPTIONS:**
 - Probe Clearance: 0.0000 [SET]
 - Probing Height: 0.0000 [SET]
 - Largest Probe Diameter: 0.0000
- Handwheel:** Vertical movement controls with buttons for .010, .001, and .0001.
- Navigation Panel:** Includes 'CHANGE TOOL', 'PROGRAM SELECT' (with LEFT, RIGHT, IN, UP, OUT, DOWN, CW, CCW, 4th-, 4th+ buttons), and a prominent red 'STOP MACHINE' button.

Horizontal Offset for Homing

There is often the need to machine out the “webbing” at the bottom of a cylinder to get the correct honing clearance. Checking the box next to “Horizontal Offset for Honing” will bring up an additional screen section on the lower right.

This is where you will set the amount, direction and speed the offset will cut. It is highly advised to run an air cut to make sure that the boring bar is offsetting in the correct direction. To offset one direction or the other click on the drop down boxes in the lower left corner and offset the direction accordingly. By default there is no offset entered. You can also change your speeds and feeds for your horizontal offset in the event that your material removal is different when cutting horizontal versus vertical.



Left and Right Locations Tab

This screen is used to set the Horizontal and In/Out stops the machine will use to bore a block. The number of In/Out and horizontal stop on this page will change with the block configuration i.e V6, V8 or inline.

The function of the Horizontal and In/Out stops will be defined in the Operating Instructions chapter of this manual.

To enter any of the Horizontal and In/Out stops press the Data box next to the Horizontal or In/Out stop you want to enter. A pop-up menu will appear. Press the desired numerical value and then press OK. The numerical data will then appear in the data box

Cylinder Bore – Bore Locations

Program Selected: Part Program DTG: 0.000 Vert 4.5000 In/Out -9.3453
 Mode Selected: Cylinder Bore Feedrate override 1.00 Horiz -18.5334 4th 0.000

Set Zeros	Vertical Stops	Left Locations	Right Locations	
Blueprint	Indicated	Probed	Difference	
Copy Values	MOVE 1	MOVE 2	MOVE 3	MOVE 4
Horizontal	0.0000	0.0000	0.0000	0.0000
In/Out	0.0000	0.0000	0.0000	0.0000
Move In/Out	BORE 1	BORE 2	BORE 3	BORE 4
0.0000				

HANDWHEEL Angle 45.00

Vertical .010 .001 .0001
 Horizontal .010 .001 .0001 4th .010 .001
 In Out .010 .001 .0001 Spindle 10x Coarse

PROBE LEFT START PROBING
 BORE LEFT
 START AUTO CYCLE

STOP MACHINE

There are three (3) different modes you can operate the machine in on these screens, Blueprint, Indicated and Probing.

Blueprint

This mode of operation allows you to enter specific values for the bore locations from a blueprint type document.

It is helpful to have the blue print numbers entered on this screen even if you are not going to bore to the blueprint locations on a particular block. They help to set the general area of the bore if you are manually centering (indicating) or probing the block.

Move Buttons

When pressed, these buttons will move the machine, under power, to the Horizontal and In/Out positions shown in the data boxes below the Move button. The Vertical will move to the Clearance height before it makes the Horizontal or In/Out moves. After it has moved to the Horizontal and In/Out positions the Vertical will move to the Centering Height. After this, all motion stops.

Bore Buttons

Pressing this button once will cause it to turn yellow. This indicates when the “Bore Left” button is pressed this cylinder will not be bored.

Touching this button again (with a pause in between touches) will turn the button back to green. All green

bores will be bored if the “Bore Left” button is pressed. The control will ask you if you sure you want to bore the selected bores.

Double Clicking a Bore button will keep it green and turn all other bore buttons yellow.

Indicated

This screen is designed to manually indicate each cylinder in for it's specific location.



Set Buttons

Once a cylinder has been indicate, pressing the associated Set Button will take the current machine position and place the values in the Data Box associated with that cylinder.

Copy Values

Pressing this button will bring up another window where you can select to copy the In/Out and Horizontal values from Blueprint, Indicated or Probed screen.

Difference

Checking this Box will cause a green check mark to be placed in the box. The Data Boxes will then display the difference in values from the blueprint screen to the indicated screen. This is helpful to know how far the cylinders actual location is from blueprint values.

Bore Left and Right

Pressing this button will cause the entire Left or Right bank to be bored automatically. The Bore buttons that are yellow will not be bored though.

Probing

The probe is an option on the F69ATC machine.

This screen is designed to automatically probe one or all of the cylinders.

Program Selected: Part Program DTG: 0.000 Vert 4.5000 In/Out -9.3453
 Mode Selected: Cylinder Bore Feedrate override 1.00 Horiz -18.5334 4th 0.000

Set Zeros	Vertical Stops	Left Locations	Right Locations	
BluePrint	Indicated	Probed	Difference	
Copy Values	MOVE 1	MOVE 2	MOVE 3	MOVE 4
Horizontal	0.0000	0.0000	0.0000	0.0000
In/Out	0.0000	0.0000	0.0000	0.0000
Move In/Out	PROBE 1	PROBE 2	PROBE 3	PROBE 4
0.0000	BORE 1	BORE 2	BORE 3	BORE 4
	0.0000	0.0000	0.0000	0.0000

HANDWHEEL
 Vertical .010 .001 .0001
 Horizontal .010 .001 .0001 4th .010 .001
 In Out .010 .001 .0001 Spindle 10x Coarse

Angle 45.00
 PROBE LEFT START PROBING
 BORE LEFT
 START AUTO CYCLE

STOP MACHINE

Probe Buttons

Pressing this button will cause a probing routine to be run on the associated cylinder.

Probe Left or Right

Pressing this button will cause the entire Left or Right banks to be probed automatically.

Probed Diameter

This Data Box will display the diameter of the cylinders as they are probed.

Lifter Bore

The Lifter Bore Mode and its buttons operate identical to the Bore Mode with a couple of exceptions.

On the Program Vertical Stops screen, lower Clearance Offset is not an option.

After a bore is complete the spindle will not offset .020" for tool clearance unless the "Horizontal Offset after Cycle" box is checked. This is used when a single point boring tool is used for lifter boring.

Cylinder Bore 4 Axis

Most of the Control Definition in the 4th axis is the same as the 3 axis version of software. Only the differences or new features will be discussed in this section.

Set Zero Tab:

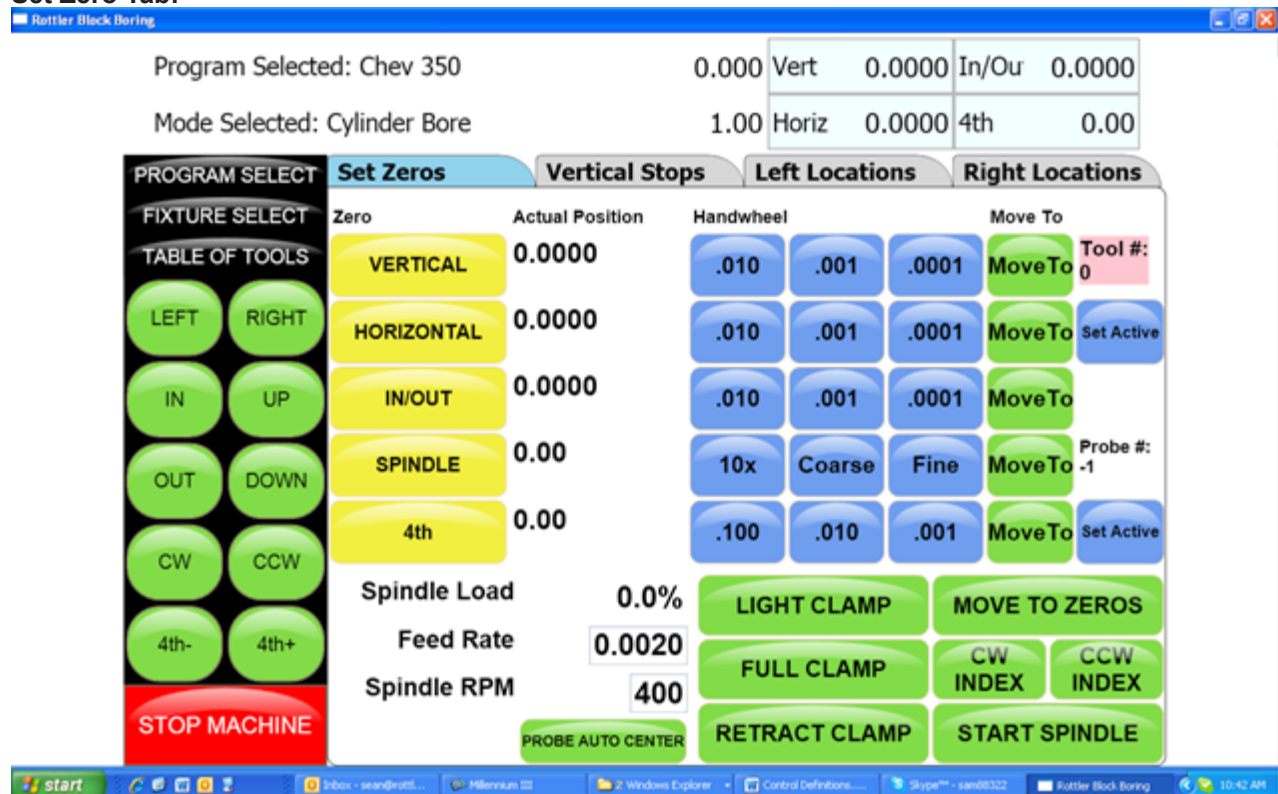

Jog Controls

4Th-

Pressing this button will cause the 4th axis to rotate in a negative direction while held.

4Th+

Pressing this button will cause the 4th axis to rotate in a positive direction while held.

4th Axis Degree and Move

Touching the 4th Axis Degree Data Box will bring up a Pop-Up Menu so a degree can be entered. Once a value is entered (even zero), pressing the Move button will move the 4th axis to that position.

4th axis Brake

This shows the status of the 4th axis brake as well as manually turning the brake on and off. When the 4th axis is rotated using the jog controls the fixture will automatically switch the brake On and Off.

Light Clamp

Pressing this button will cause light pressure to be exerted from the Tail Stock towards the Head stock. When the 4th axis is rotated using the jog controls the fixture will automatically switch from Full to Light clamp and back.

Full Clamp

Pressing this button will cause full pressure to be exerted from the Tail Stock towards the Head stock.

Retract

Pressing this button will cause the tail stock to fully retract. A dialog box will appear when this button is pressed to assure you want to retract the tail stock. This is to prevent an accidental retraction when a block is in the fixture.

ATC Specifications

ITEM	SPECIFICATION
Maximum Tool Diameter (Full Pockets)	3.1" (80mm)
Maximum Tool Diameter (Empty Holder Each Side)	5.9" (150mm)
Maximum Tool Diameter (2 Empty Holders Each Side)	10.5" (267mm)
Maximum Tool Weight	17.6lbs (8kg)
Maximum Tool Capacity	24
Tool to Tool Changing Time	1.8 seconds
Tool Indexing Time	0.5 seconds

Table Of Tools

The Table Of Tools is a very powerful feature. Only the program specific uses will be described here.

Table Of Tools General Information

The Table Of Tools is used to set different tool lengths so multiple tools can be used in one program and reference the same vertical zero position.

As an example, if you were to use two boring bars in one program. One boring bar is 8.000 long and the other is 4.000 long. There is then a 4.000 difference in length between the spindle and the end of the bore bar. Using the table of tools allows tools to be set up from a common vertical(or Z) location even though the length from the spindle to the tip of the cutter will vary from one cutter to the next. The process of using the table of tools maximizes the efficiency of the machine because it eliminates the need to have to redefine the cutter lengths every time the block or work piece is changed. This is true if you have one common location you are using to reference each of the blocks. For example, if you use the mains as an origin for all blocks then you can set all of the cutters at the centerline of the mains or through the center of the 4th axis(No difference). See example below on how to set up tools. As a rule of thumb when using the Table of Tools in programming there will not be a need to use your vertical zero button in the program itself(ie boring cycle, mill cycle). Of course there are always exceptions to the rule and there will be some circumstances where the vertical zero button will be needed in combination of the table of tool. We will cover this in a later segment. You will typically rely on the table of tools for all of your vertical Z height positioning. One way to double check to be certain that you have touched of the tool correctly is to physically move the cutter to the top of a deck of a known height and the vertical zero should read that height. As an example, you have tool number 1 active and in the spindle. You have defined your z zero through the center of the mains. You know that the distance from the center of the main to the top of the deck is 9.000. Wheel the cutter down to the deck and look at your vertical numbers on the DRO. This should read close to 9.000. You must be sure that this is the tool that is active and highlighted in red in the table of tools.

Accessing Table Of Tools

Select TABLE OF TOOLS which you will see circled in red. This will open up the Table Of Tools page.

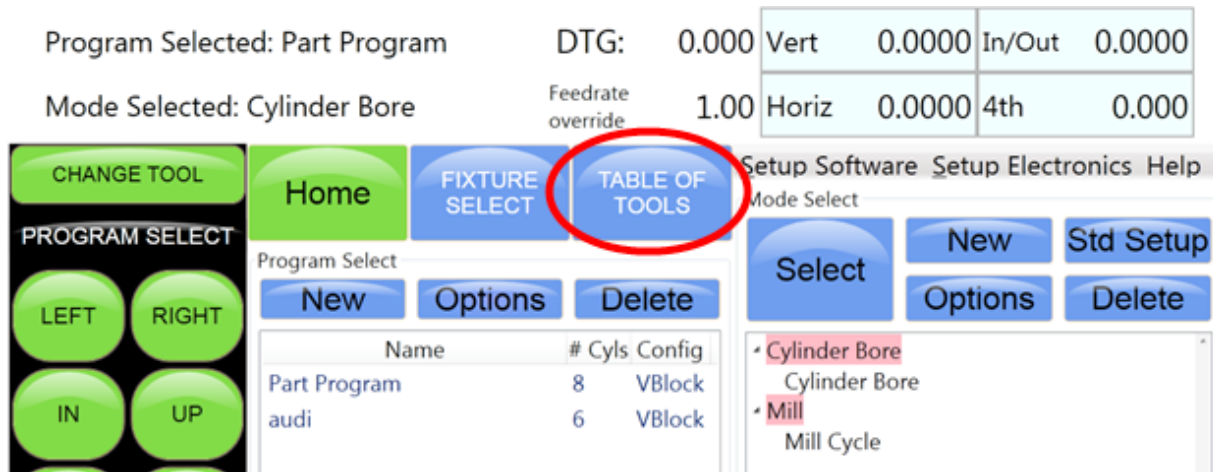

On this screen you will be able to Add, Remove or Set a tool Active (Calls tool up that is in magazine and loads to spindle. Once in spindle the tool is considered active and the tool height can now be defined).

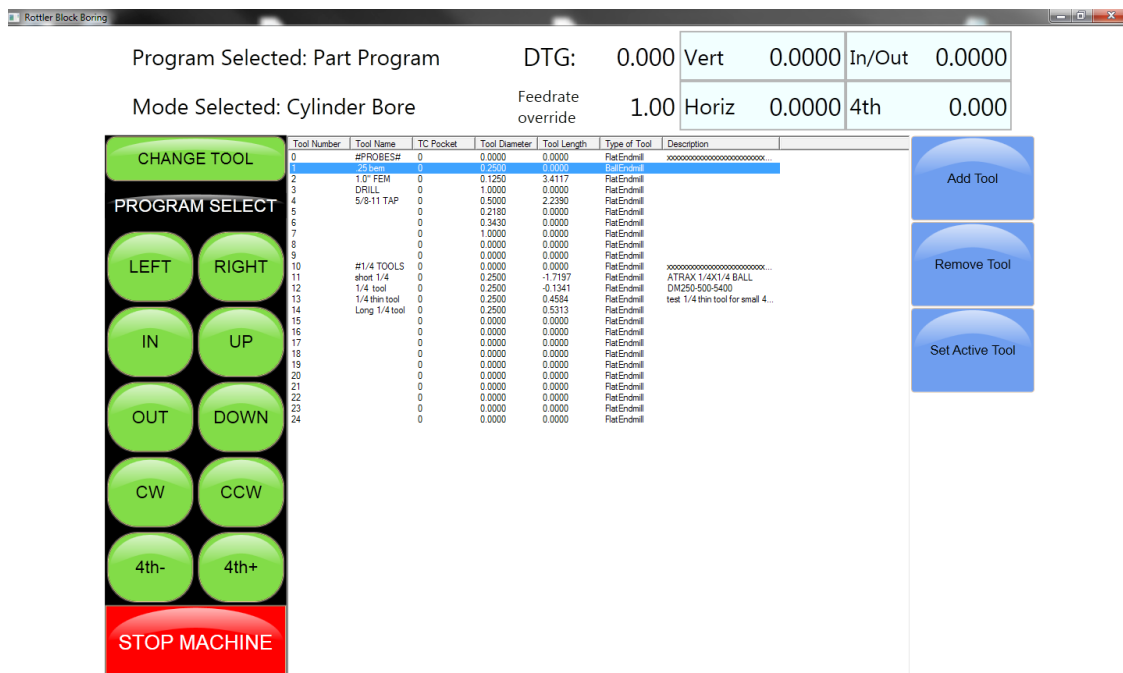

Tool Number versus TC Pocket

Looking at the Table of Tools you will see that there is a column for Tool Number and TC Pocket. This tool changer is considered a Random Access Toolchanger. What this means is as the tools begin changing from one tool to another they begin “trading” pocket locations. For example, let say you placed tool # 1 in pocket #1, initially. Then you placed tool #10 in Pocket #10, initially. Machine completes machining with tool # 1 then you have a callout for tool #10. What happens with this system is that pocket #10 will move to the tool change position and swap tool #1 for tool #10 leaving tool #1 in pocket #10. So in this case the tool moved from pocket #1 to pocket #10. BUT, the tool #1 will still be considered Tool # 1 even though it now resides in pocket #10. So, if the magazine is completely loaded with tools you could imagine that as different tools are being pulled up their pocket locations are changing constantly. The software keeps track of all of the pocket locations. So as in this example if you were to look under the TC Pocket location you will see that for tool # 1 the TC pocket location will read 10. It is important to know that when you initially set up the Table of Tools you must assign a pocket location to a tool. If there is a zero in the column the spindle will simply move to location and do nothing. It needs to have a pocket number assigned. Once you have a tool defined and assigned to a pocket all you have to remember at this point is the tool number and tool name. For all intensive purposes you don't really care which pocket they are in. All you care about is when you activate a certain tool number it pulls up the tool you want regardless of which pocket it resides in. Bottom line is that you can initially set up the tools so that the tool pocket matches the tool # but once you start to make tool changes the tool number will almost never be the same as the tool pocket. Only by chance will they be the same. Also note that if the tool # has a defined pocket of (-1) that mean this is the tool that is supposed to be in the spindle. Obviously if it is in the spindle it is not in a pocket therefore not TC pocket can be designated.

Add Tool

To add a tool to the Table of Tools press Add Tool. This will open another window. Here you will name the Tool you are adding. Such as 2.9 production Stub. It is important to give an accurate name to the tool. You want the tool easily identifiable by its name. You will also need to define the tool pocket number. Please note that there is a box that you can check on labeled “Fixed Pocket Access(Large Tool). This is for cutters that have a greater diameter than 3.0”. As an example a typical flycutter used for surfacing decks is 10.0” diameter. I this case you would definitely want to select the Fixt Pocket box and leave the two pods just before and just after the flycutter in the drum(total of 5 pods including the pod the fly cutter is loaded in. The only other data box the Rottler software uses is the Length Data Box. This will be discussed later. Press OK.

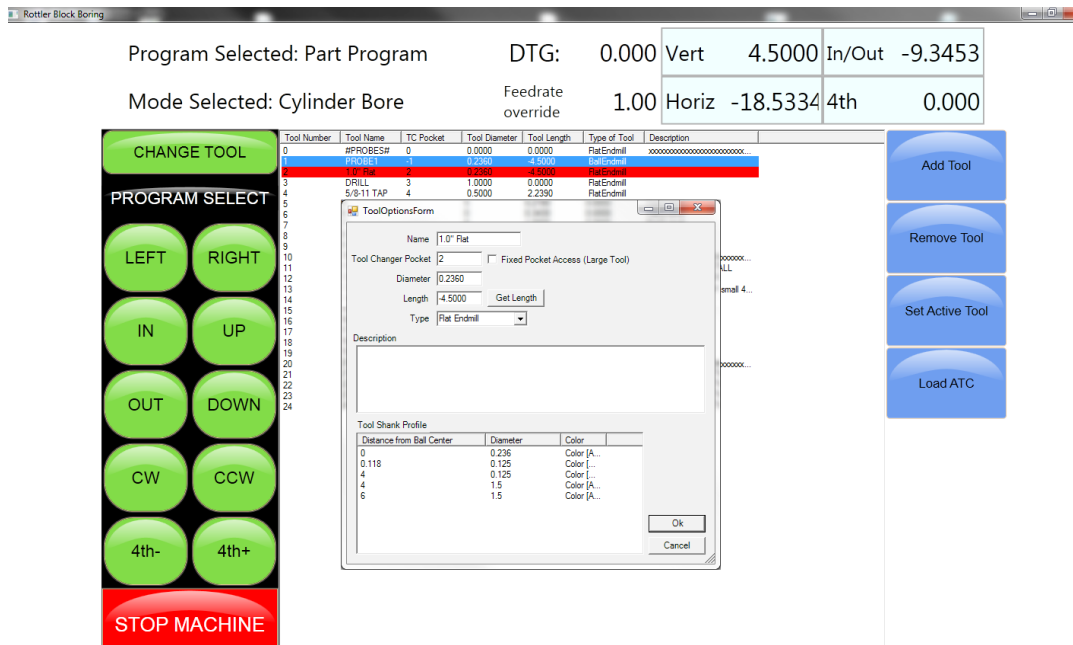

The Added tool will now show in the Table of Tools.

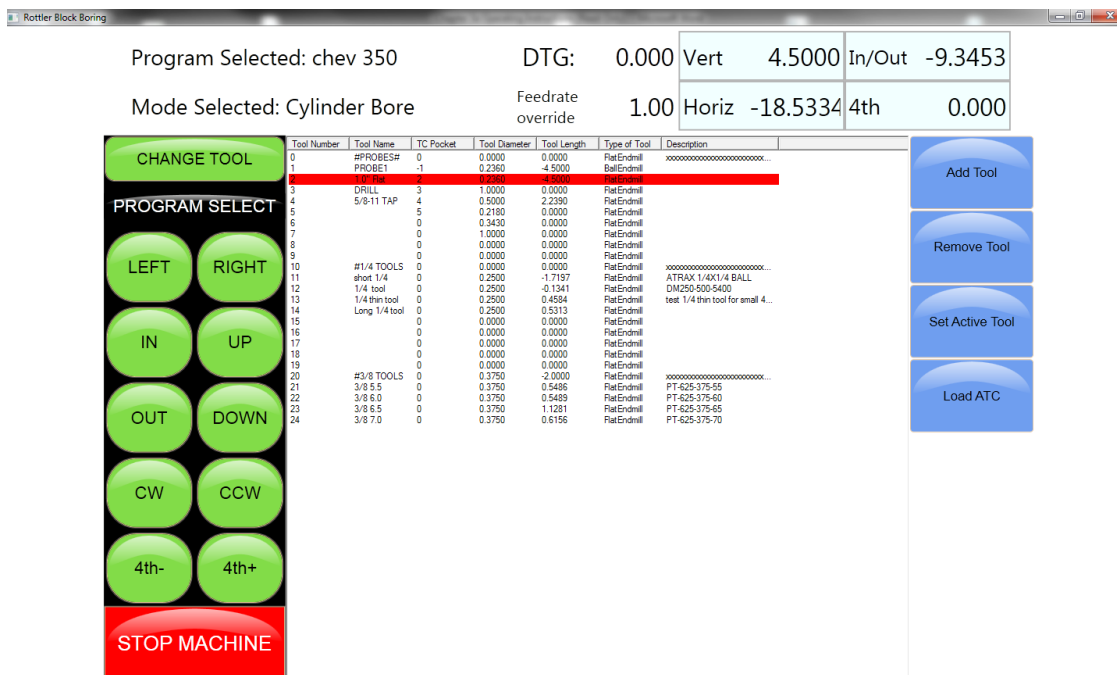

Remove Tool

Pressing this button will remove the highlighted tool from the Table of Tools.

Set Active Tool

Pressing this button will set the highlighted tool to an Active Status which triggers the tool changer to perform a tool change to that specific tool. Any Vertical offset associated with that tool will be used when a program is run. You can tell which tool is active because it is highlighted in Red. When setting a tool active another window will open. This is the Tool Change Form. It is basically there to verify the tool information before it is set to an active status. Verify the information and press OK.

This window will open when the machine does an automatic tool change. This will be discussed in

To set Tool Offsets you will need a fixed vertical reference point on the machine that does not change such as the head stock of the 4th axis or Performance Fixture or the head or tailstock of the auto 4th axis. Install the first tool such as the 2.9 Production Stub with Cutting insert installed. Bring the cutting insert down until it just touches the flat on the tail stock of the 4th axis fixture. Go to the TABLE OF TOOLS and double click the 2.9 Production Stub tool. Select Get Length from that window. This will bring up the Tool Length window.

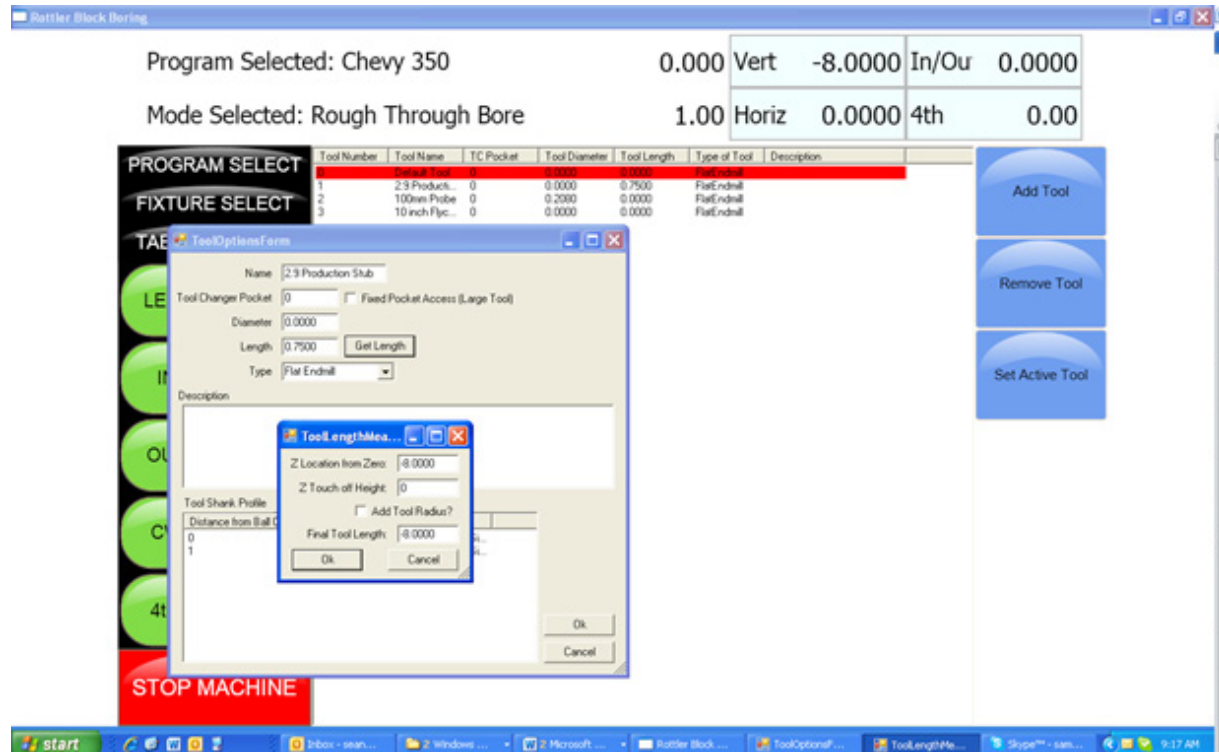

Z Location from Zero

This is the distance the Vertical Axis is from the home position. NOT where the operator has set the Vertical Zero in the program. This value is set by the computer automatically. In this example the tool just touched the flat at 8.0000.

Z Touch Off Height

This value is an additional value you want added to the Z location from zero. For example, if you wanted to use the center of the Crankshaft as the vertical reference point, but you are touching the tool off of the flat of that head stock, you would enter the distance from where you are touching off to the center of the Crank (this value is stamped into the headstock by Rottler). The values from Z Location from Zero and Z Touch off Height are added together by the computer to get the Final tool Length value. If you are not referencing another vertical position then this value will remain 00.000.

Add Tool Radius?

Checking this box will add the Tool Radius to the Final Tool Length. This is not used in the Rottler programs and should remain unchecked for all tools.

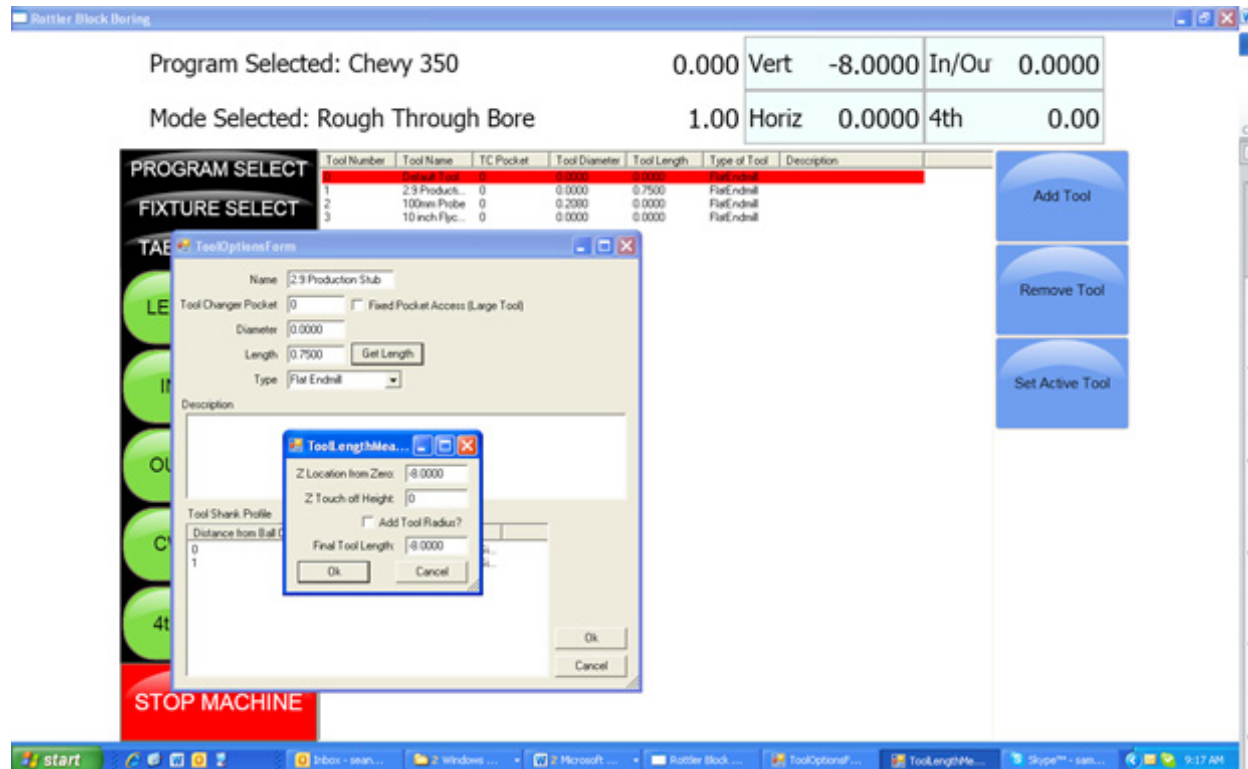

Repeat this procedure for each tool. Touch ALL of them off from the same point. The video shows an example of touching off the flat of the tailstock. From that point to the center of the main line would be 3.5 entered into "Z touch off height"

When running a Rottler program the cutting insert for each tool will reference the Vertical Zero the operator set in the program and come into contact with the surface to be machined at the same vertical value.

Applying Table of Tools to Rottler Programs

The use of the Table of Tools to specific Rottler programs such as Bore and Mill will be defined in Chapter 3 Operating Instructions.

Fixture Select

This is also a very powerful tool. It is not generally used in the Rottler Programs. It's basic function is to offset a program and table of tools a set distance on each axis (if desired) and run the same program without resetting axis zero points.

For example, if you have fixtures that are identical but are set at a different location on the table you can set the difference values in the table of fixtures and run the program.

It is recommended this is not used unless you are a very experienced operator.

This page intentionally left blank

OPERATING INSTRUCTIONS

Contents

Operating Instructions	5-1
Loading a Block.....	5-1
Performance Fixture 650-3-1 Boring	5-1
Performance Fixture 650-3-1 Lifter Boring	5-4
Lower End Machining Package 650-3-1A	5-5
Block End Truing Fixture 650-3-30	5-7
Block End Truing Fixture 650-3-30 when used with Cam Boring	5-11
Cam Tunnel Boring	5-12
650-3-20A Pan Rail Wedge Fixture	5-13
Installation and Operation.....	5-13
Mounting.....	5-13
Loading the block	5-14
Switching Banks	5-15
V6/V8 Manual Fixture Assembly 502-1-72H.....	5-16
650-3-59 Auto Performance Fixture	5-18
Using the 4th Axis Fixture	5-21
Loading an engine block.....	5-22
Readjusting tailstock piston alignment	5-23
Block Blueprint Dimensions.....	5-25
Block Dimensions: Cylinder Bore Dimensions	5-25
Block Dimensions: Other Dimensions	5-27
Chrysler 318 Dimensions.....	5-29
Chevrolet Big Block Dimensions	5-30
Chevrolet Small Block Dimensions	5-31
Ford 289-302-351W Dimensions	5-32
Ford 351C-400 Dimensions	5-33
Ford 390-427 Dimensions	5-34
General Machine Information	5-35

Homing.....	5-35
Building Programs	5-35
Table of Tools for 3 and 4th Axis Bore Mode.....	5-35
Building a Program with Table of Tools.....	5-35
Assign Tools.....	5-35
Setting Tools Active.....	5-37
Create a Block Program.....	5-38
New.....	5-38
Options	5-38
Creating Operating Modes for a Block Model	5-38
New.....	5-39
Std (Standard) Setup	5-40
Select	5-40
Options	5-40
Cylinder Bore Mode 3 and 4 Axis.....	5-41
Setting Zeros	5-42
Horizontal and In/Out Zero.....	5-42
Vertical Zero	5-43
Spindle Zero	5-43
Blueprinting	5-44
Programming Vertical Stops.....	5-44
Block Clearance	5-44
Centering Height.....	5-45
Start Boring Height.....	5-45
Bottom of the Bore	5-45
Horizontal Offset for Honing.....	5-46
Start Offset Height	5-46
Horizontal Offset	5-46
Change Speeds at Horizontal Offset.....	5-46
Washout Cycle	5-46
Stop and Index Spindle after Cycle.....	5-46
Bore Locations	5-47
Left Locations	5-48
Right Locations.....	5-48
Boring a Block.....	5-49
Running the Program	5-49
Indicating.....	5-50
Vertical Zero	5-50

Programming Vertical Stops	5-51
Block Clearance	5-51
Centering Height	5-52
Start Boring Height	5-52
Bottom of the Bore	5-53
Bore Locations	5-54
Boring a Block	5-56
Probing	5-56
Vertical Zero	5-56
Programming Vertical Stops	5-57
Block Clearance	5-57
Centering Height	5-57
Start Boring Height	5-57
Bottom of the Bore	5-58
Probe Height	5-58
Bore Locations	5-59
Probe Auto Center	5-59
Automatic Probing Procedure	5-59
Boring a Block	5-60
Cylinder Bore Mode 4th Axis	5-60
Setting Zeros	5-60
4th Axis (Rotational) Zero	5-60
Finding the In/Out (Y) Axis Zero with 4th Axis	5-60
Building Programs with the 4th Axis	5-60
Setting Vertical Clearance with 4th Axis	5-60
Mill Mode 3 Axis	5-61
Setting Zeros	5-61
Horizontal Zero	5-61
In/Out Zero	5-61
Vertical Zero	5-61
Mill Operation	5-63
End	5-63
Horizontal End	5-63
Amount Per Pass	5-63
Vertical Start	5-63
Vertical End	5-63
Copy Lowest Copy Highest	5-63
Rough Settings	5-64

Rough Feed Rate	5-64
Rough Spindle RPM.....	5-64
Finish Cut Settings.....	5-64
Finish Amount	5-64
Finish Feed Rate	5-64
Finish RPM	5-64
Start Auto Cycle.....	5-65
Mill Mode 4th Axis	5-65
Setting Zeros	5-65
Horizontal Zero.....	5-65
In/Out Zero.....	5-65
Vertical Zero	5-65
Mill Operation.....	5-67
End.....	5-67
Horizontal End.....	5-67
Amount Per Pass	5-67
Vertical Start	5-67
Vertical End	5-67
Copy Lowest Copy Highest	5-68
4th Axis Angles	5-68
Left Bank Angle.....	5-68
Right Bank Angle	5-68
Rollover Vertical Clearance.....	5-68
In/Out Offset	5-68
Rough Settings	5-68
Rough Feed Rate	5-68
Rough Spindle RPM.....	5-68
Finish Cut Settings	5-68
Finish Amount	5-68
Finish Feed Rate	5-68
Finish RPM	5-68
Cut Left and Cut Right	5-69
Start Auto Cycle.....	5-69
Milling Using Automatic Deck Probing.....	5-70
Table of Tools for Milling.....	5-70

Assigning Tools	5-72
Setting Tools Active	5-73
Building a Program Using Table of Tools	5-73
Left Deck Probe.....	5-74
Right Deck Probe	5-74
Auto Probing	5-74
Auto Milling	5-75
Vertical Start	5-75
Vertical End	5-75
Cut Left or Cut Right.....	5-75
Start Auto Cycle	5-75
Lifter Bore Mode 3 Axis	5-76
In / Out Zero	5-76
Start Boring Height	5-76
Lifter Bore Angle	5-76
Lifter Bore 4th Axis	5-77
Start Boring Height	5-77
Lifter Bore Angle	5-77
Calculate In/Out.....	5-77
Line Bore Mode	5-78
Mounting and Aligning the 90 Degree Head	5-78
Setting Zeros	5-78
Horizontal Zero.....	5-79
In/Out and Vertical Zero.....	5-79
Programming Vertical Stops	5-80
Bore Centerline	5-80
Block Clearance	5-80
Programming Horizontal Stops	5-80
Programming Bore Length	5-80
Running the Auto Cycle	5-80
Thrust Cutting	5-81
Setting Zeros	5-81
Horizontal Zero	5-81

Dimensions & Auto Cycle	5-82
Thrust Dimensions	5-82
Outside	5-82
Inside	5-82
Cutter	5-82
Clearances	5-82
Vertical	5-82
Horizontal	5-82
Dimensions	5-82
Main Width	5-82
Insert Width	5-83
Left Depth of Cut	5-83
Right Depth of Cut	5-83
Cut Right Side	5-83
Cut Left Side	5-83
Description and Running of the Auto Cycle	5-83
Start Auto Cycle	5-83
Cam End Tunnel Boring	5-83
Cam Tunnel Boring	5-85
Setting Cutting Size	5-86
Setting Vertical Stops	5-89
Setting Horizontal Stops	5-89
Auto Cycle	5-89
Manual Bore	5-89
Recommended Boring Procedure	5-89
Con Rod	5-90
Manual Screen	5-90
Setting In/Out and Horizontal Zero	5-90
Setting Vertical Zero	5-91
Program Screen	5-92
Measure	5-92
Clearance	5-92
Centering	5-92
Start Bore	5-92
Bore Depth	5-92
Center Set	5-92
Automatic Screen	5-93

Fixture Control Panel.....5-94
Set up procedure for conrod fixture5-94
Backing Up and Restoring Block Profiles.....5-96
Backing Up and Restoring RCam Programs5-103
Backing Up and Restoring RCam Tables 5-111
Using 3rd Party Tooling in Rottler Machines with CAT 40 Tooling..... 5-119

Operating Instructions

The purpose of this chapter is to explain and then guide the operator from loading blocks to running an automatic cycle.

All modes of operation will be discussed in this chapter.

Loading a Block

Performance Fixture 650-3-1 Boring

Install and align the performance fixture head stock on the left hand side of the table as shown below. Follow the alignment procedures for the Performance fixture in the Maintenance section of this manual. Tighten the Head Stock to the table securely using the four Hex bolts and T-Nuts. Install the Tail Stock onto the right hand side of the table but do not tighten down.

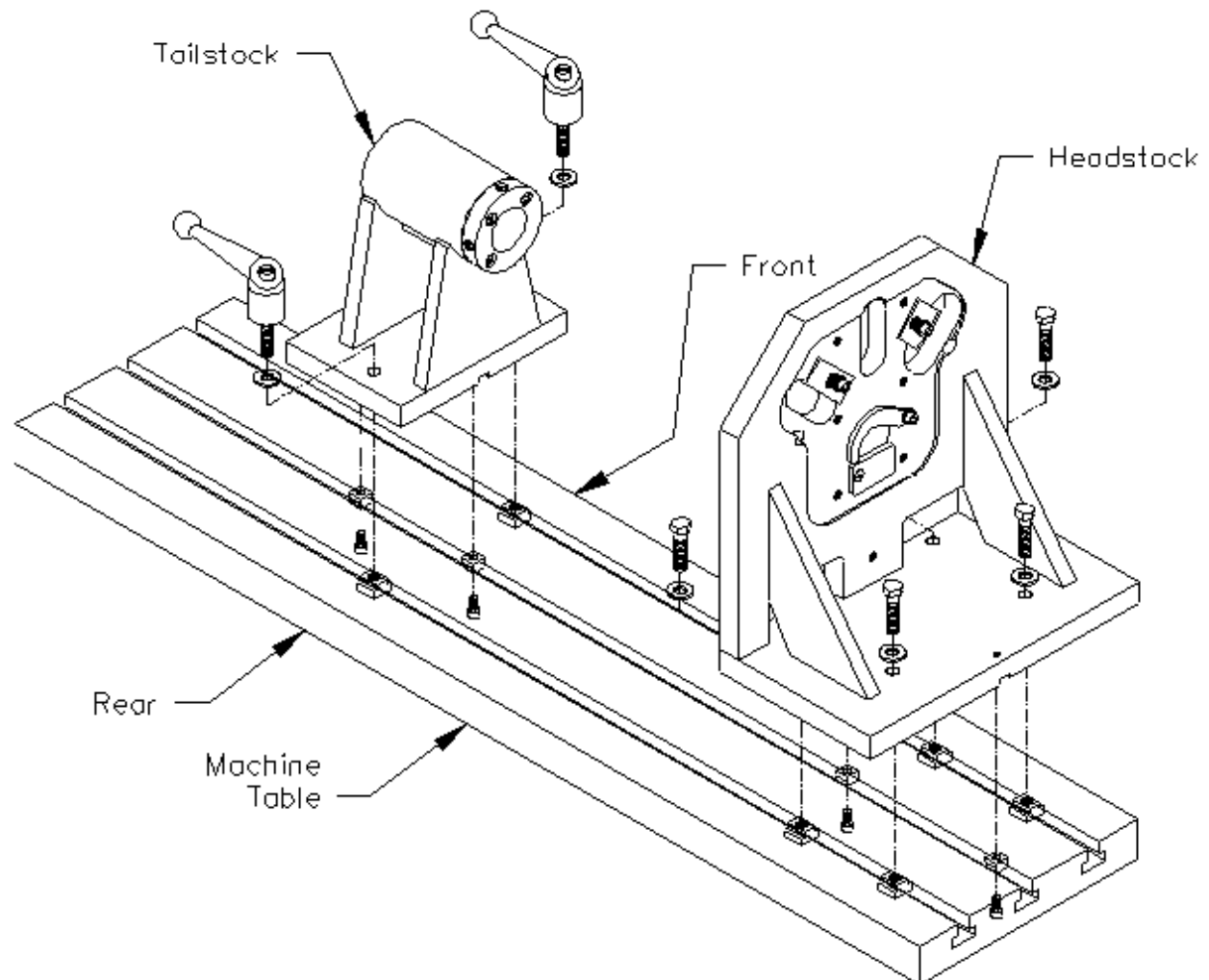

Select the correct Main and Cam bushing for the block you are going to be using from the tables in the Options section of this manual. Place bushings in block as shown below.

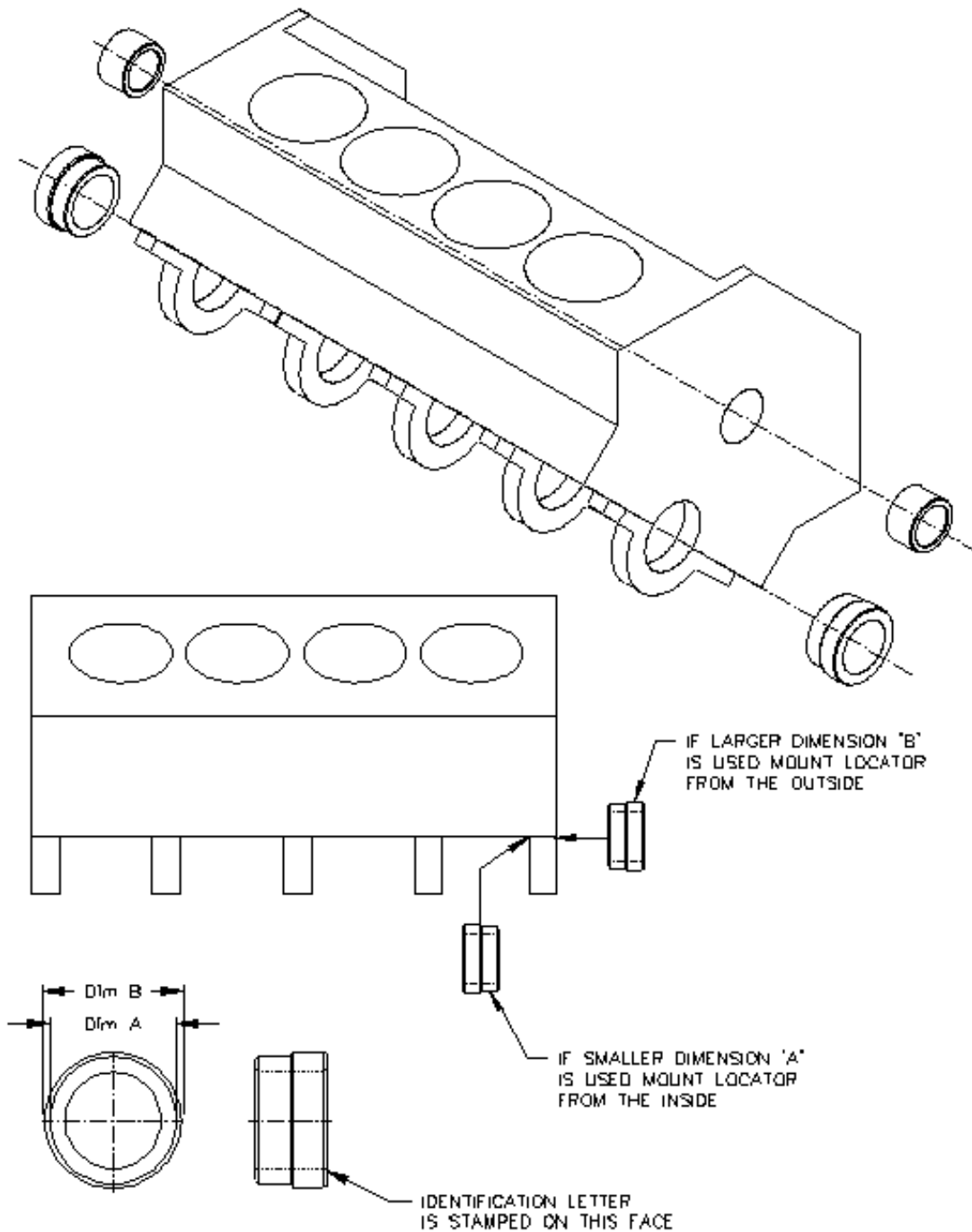

Note: Each locator covers two bearing diameters ('A' and 'B'). The unused diameter **MUST** be placed **INSIDE** the block to prevent interference with the Index plates.

- 1) Using a slow travel hoist, position the block between the Head stock and Tail stock with the Bell housing end of the block towards the Head stock.
- 2) Slide the unthreaded end of the Main Bar through the Tail stock, both Main bushings and into the Head stock with the flat facing down. The threaded end of the Main Bar should be on the Tail stock side of the table. Slide the Lock into the groove on the Main Bar.
- 3) Rotate the block until the bank you want to bore is facing up. Make sure the cam spacer is not in the cam Bore area at this time. Slide the Cam Bar through the two Cam bushings and into the Head stock with the reduced diameter at the Head stock.
- 4) Snap the Cam spacer into place.
- 5) Push the Tail stock up to the block. Tighten the Handwheel with a quick snapping motion.
- 6) Tighten the two handles on the Tail stock.

The block and fixture are now locked in place and ready for machining.

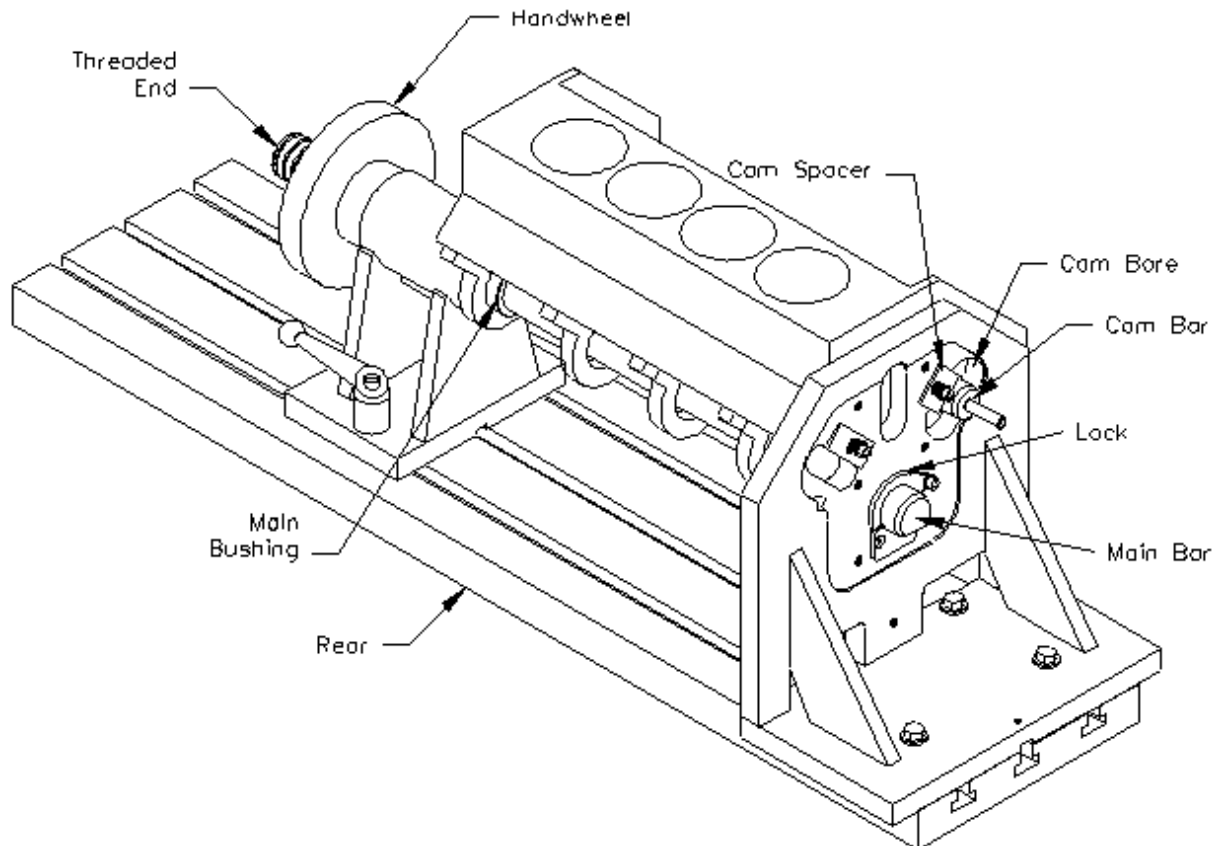

Performance Fixture 650-3-1 Lifter Boring

The same procedure for loading a block in Lifter boring as was used in Boring with an exception in the Cam Bar area.

- 1) Instead of the Cam Bar being slid through the Cam Bore to its full Diameter, the small shaft on the end of the Cam Bar is used in conjunction with spacer Blocks.
- 2) Select the correct Spacer from the Chart in the Options section of this manual for the angle of the Lifter Bores.
- 3) The Cam Spacer must be out of the Cam Bore.
- 4) See illustration below for spacer installation.

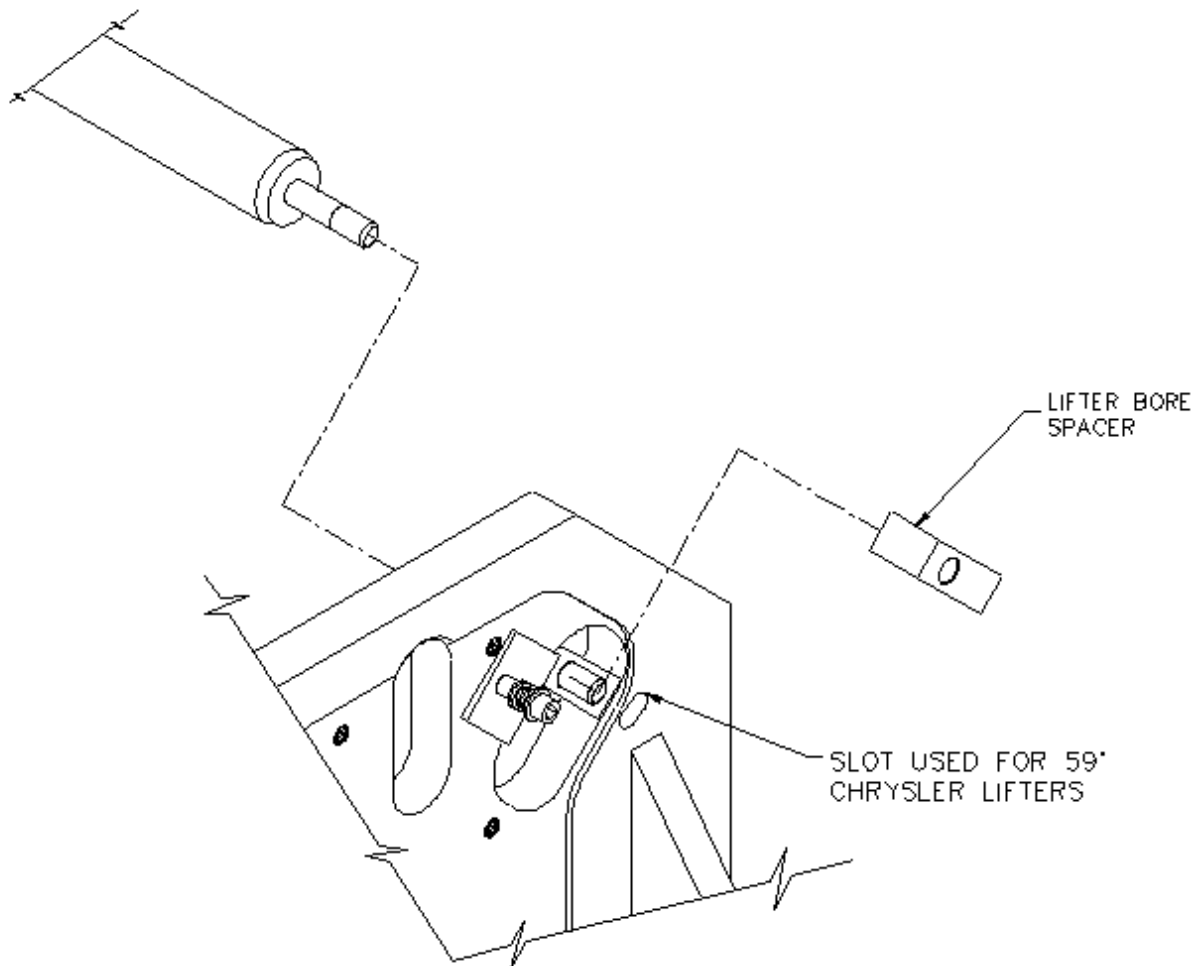

Lower End Machining Package 650-3-1A

- 1) Install and align the performance fixture head stock on the left hand side of the table as shown in the Performance Fixture section. Follow the alignment procedures for the Performance fixture in the Maintenance section of this manual. Tighten the Head Stock to the table securely using the four Hex bolts and T-Nuts.

Install the Tail Stock onto the right hand side of the table but do not tighten down.

Install the Tail stock bushings 650-3-6E and 650-3-6M into the Tail stock as shown below.

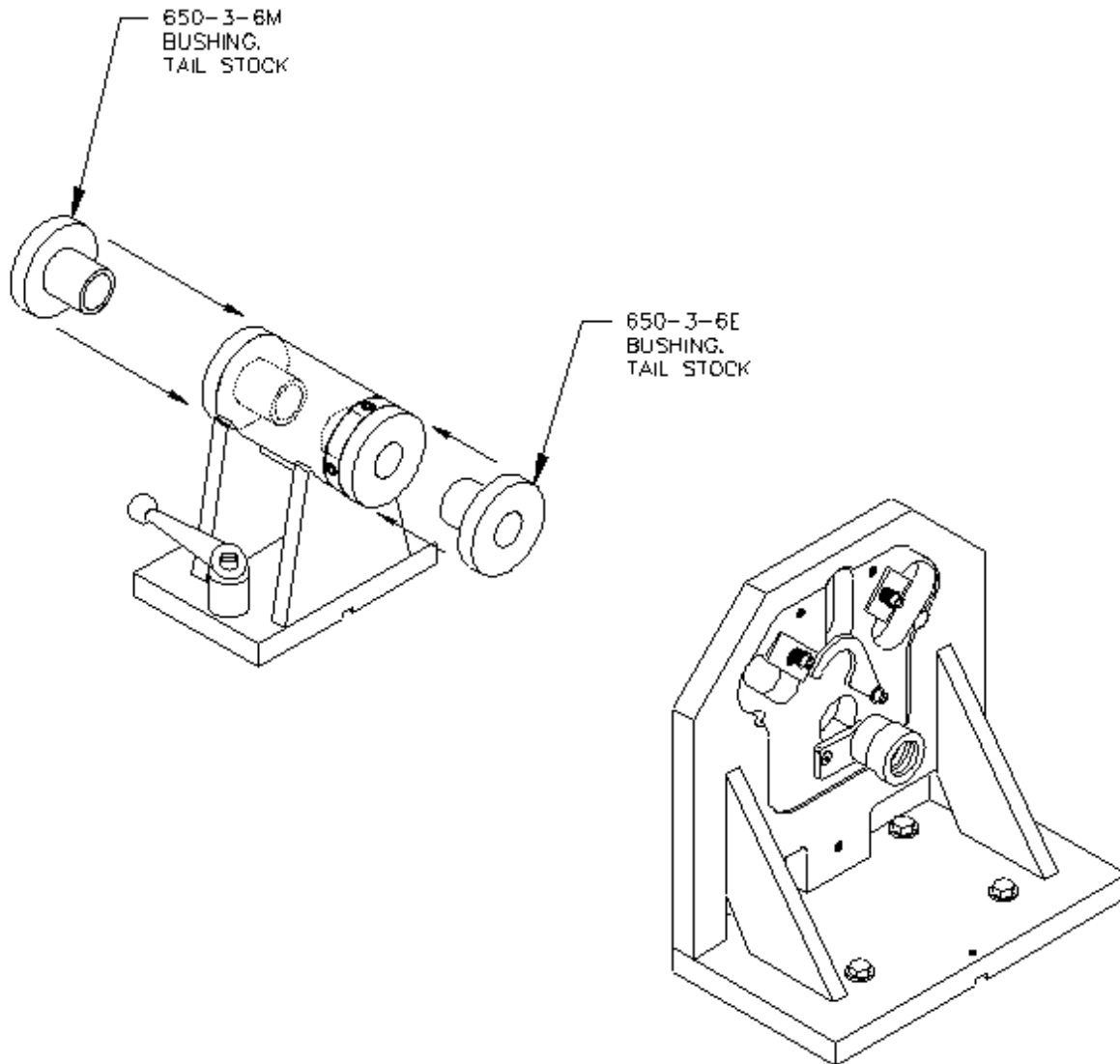

- 2) Select the correct size Cam Bushings for the block you are using and install them into the block.
- 3) Using a slow travel hoist, position the block between the Head stock and Tail stock with the Bell housing end of the block towards the Head stock with the Main Caps facing up.
- 4) Install Head stock bushing into Head stock with the flat facing down and the smaller diameter into the Main bore of the Head stock.
- 5) Slide the Cam Bar (short threaded end first) through the Tail stock bushings, Cam bushings (installed in block) and Head stock Spacer.
- 6) Thread the Cam Bar into the Head stock Bushing until tight.
- 7) Slide the Tail stock up to the block.
- 8) Snug the handwheel up to the Tail stock but do not lock in place.
- 9) Install the Leveling Jacks between the underside of the block and the bed of the machine. One each side.
- 10) Rotate the block until the Pan Rails are even to each other.
- 11) Make sure there is even pressure on each of the Leveling Jacks.
- 12) Tighten the Handwheel into place.
- 13) Tighten the Tail stock into place using the handles.

The block and fixture are now locked in place and ready for machining.

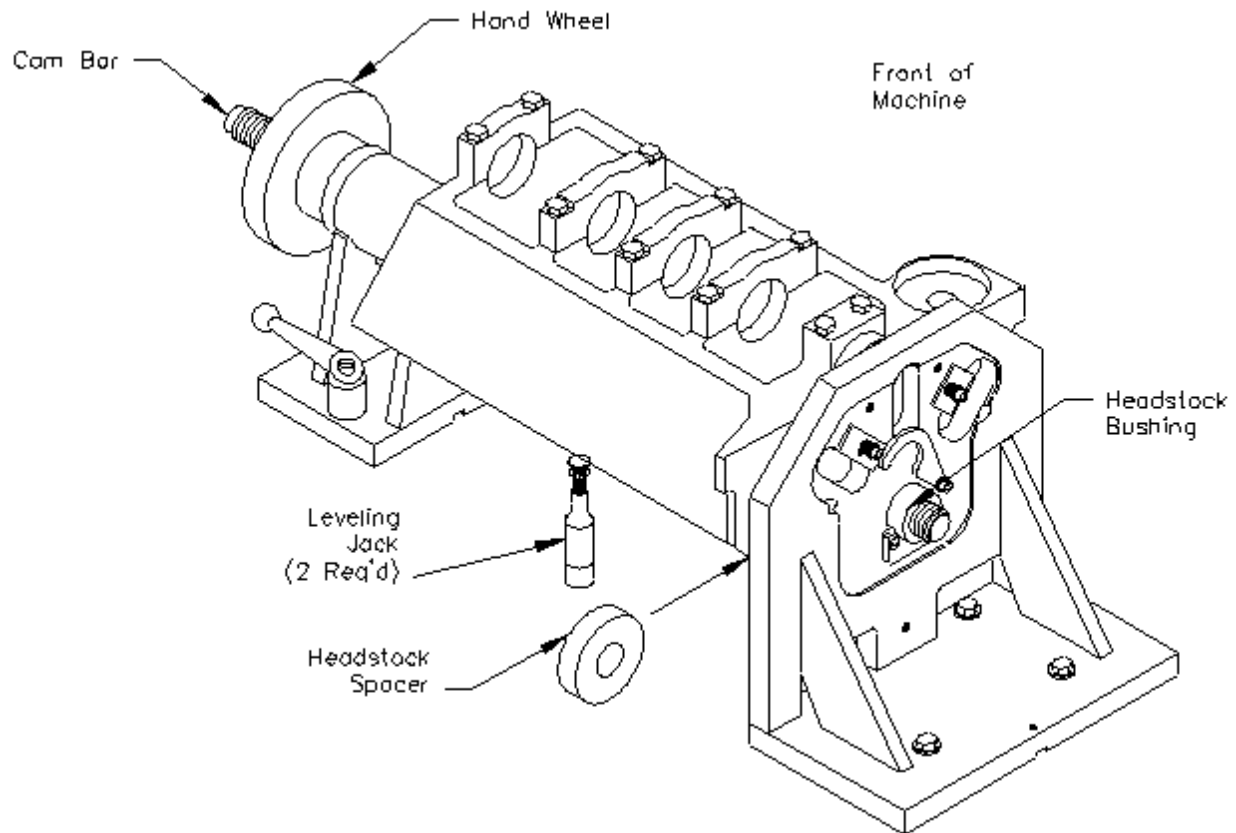

Block End Truing Fixture 650-3-30

If you are truing the ends of a block use the standard Head stock mentioned in the Maintenance section of this manual.

If you are Boring the Cam Tunnels with this fixture follow the standard Head stock in the Maintenance section of this manual plus the procedure below:

- 1) Do not have the Head stock hold down bolts all the way tight, the fixture may need to be moved slightly.
- 2) The center of the Key Way on the Head stock need to be lined up with the center of the middle Key Way on the machine bed. This will place the center of the Main bore directly inline with the center of the Cam bore.
- 3) Lock the Head stock in place.

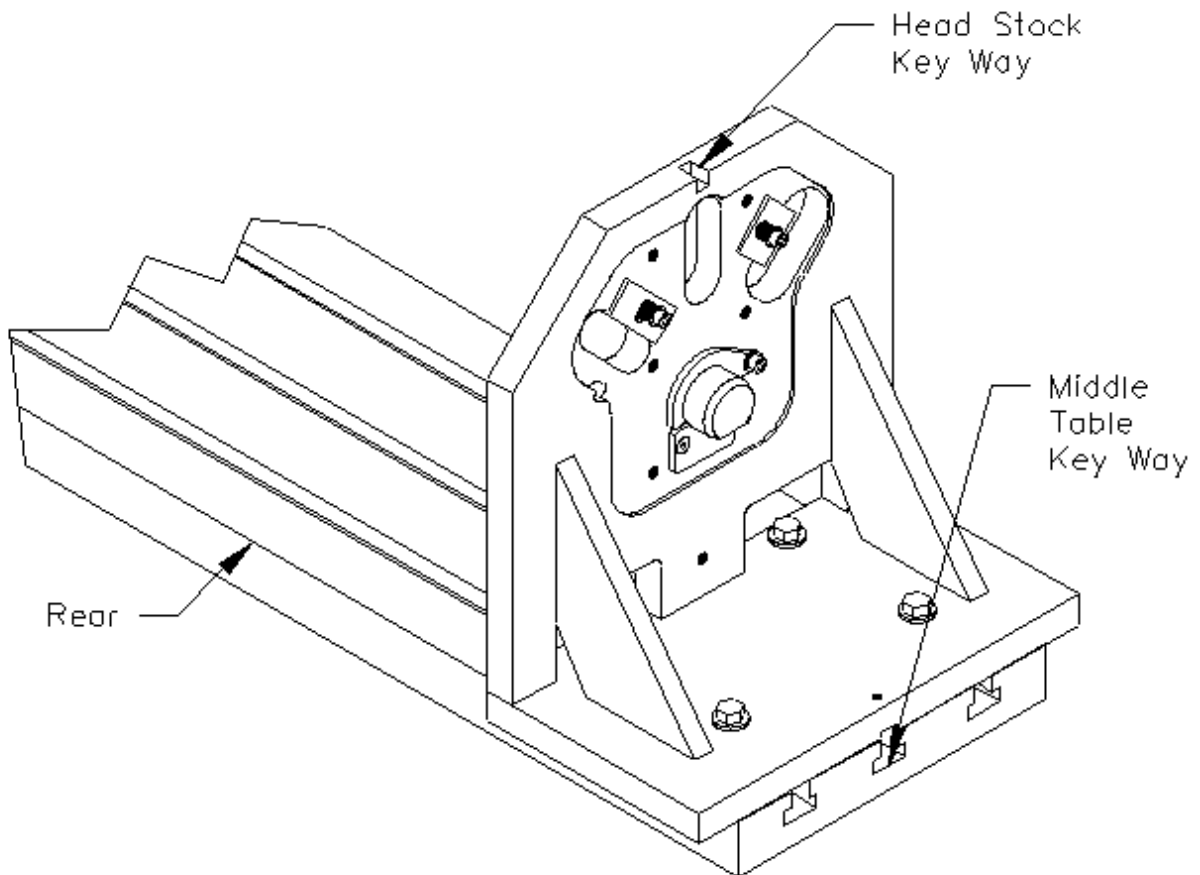

- 4) Install the Truing Fixture onto the Head stock. Slide the two Dowel pins on the Truing Fixture into the appropriate Dowel holes on the Head stock.
- 5) Bolt the Truing Fixture to the Head stock using the three supplied Hex Head Bolts.

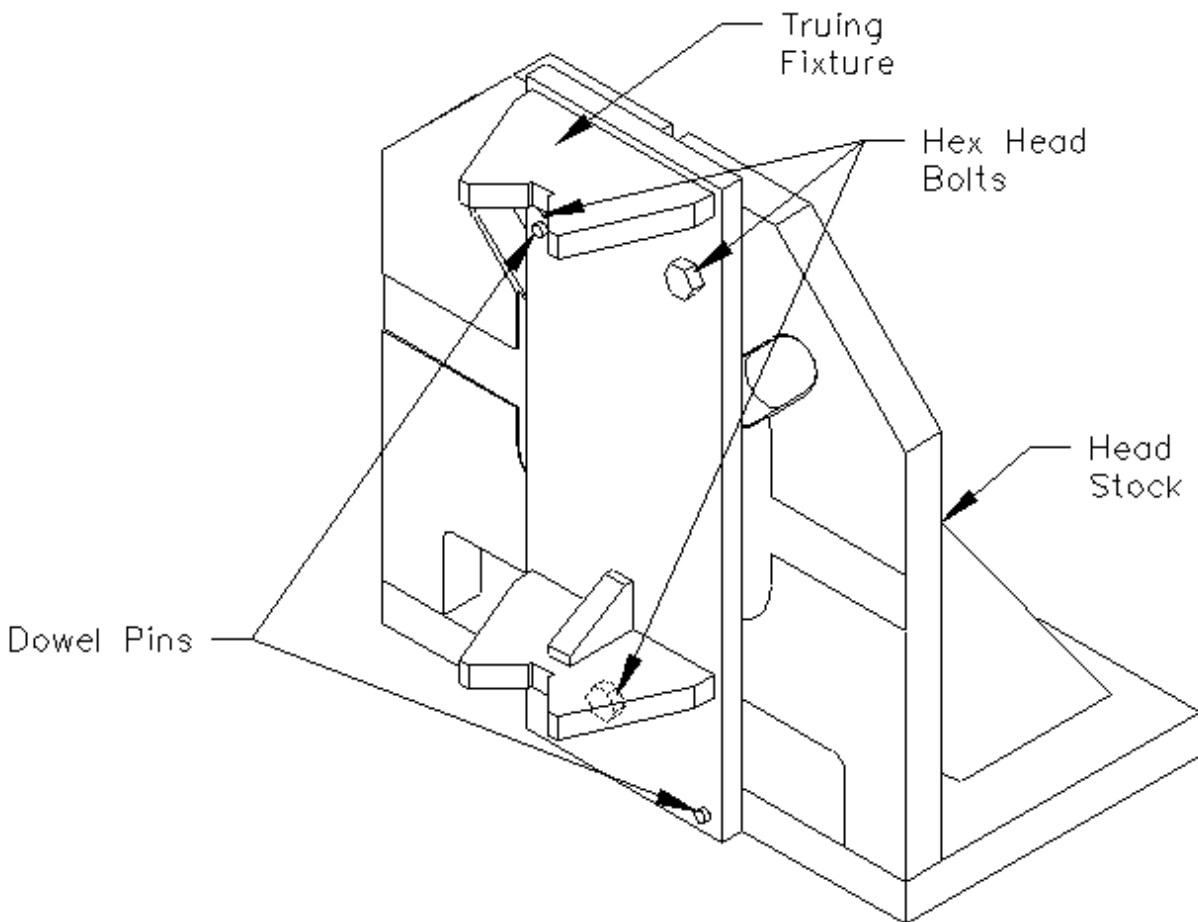

The following steps are designed to check the Vertical Bar for straightness. This Bar was checked and tested at Rottler Manufacturing. The following steps are to make sure there is not a burr or debris between any of the parts.

- 6) Slide the Main Bar through the Tail stock (threaded end first).
- 7) Thread the Handwheel onto the Main Bar.
- 8) Place the Vertical Bar into the "V" on the Truing Fixture.
- 9) Slide the Tail stock towards the Head stock until the Main Bar just touches the vertical Bar.
- 10) Tighten the Tail stock down.
- 11) Turn the Handwheel until the Main Bar holds the Vertical Bar securely in place.
- 12) Attach an indicator to the machine spindle or cutterhead and run it up and down the front and side face of the Vertical Bar. It should be within .0015 variance.

Note: Front face will only have half travel as the Main Bar obstruct full travel.

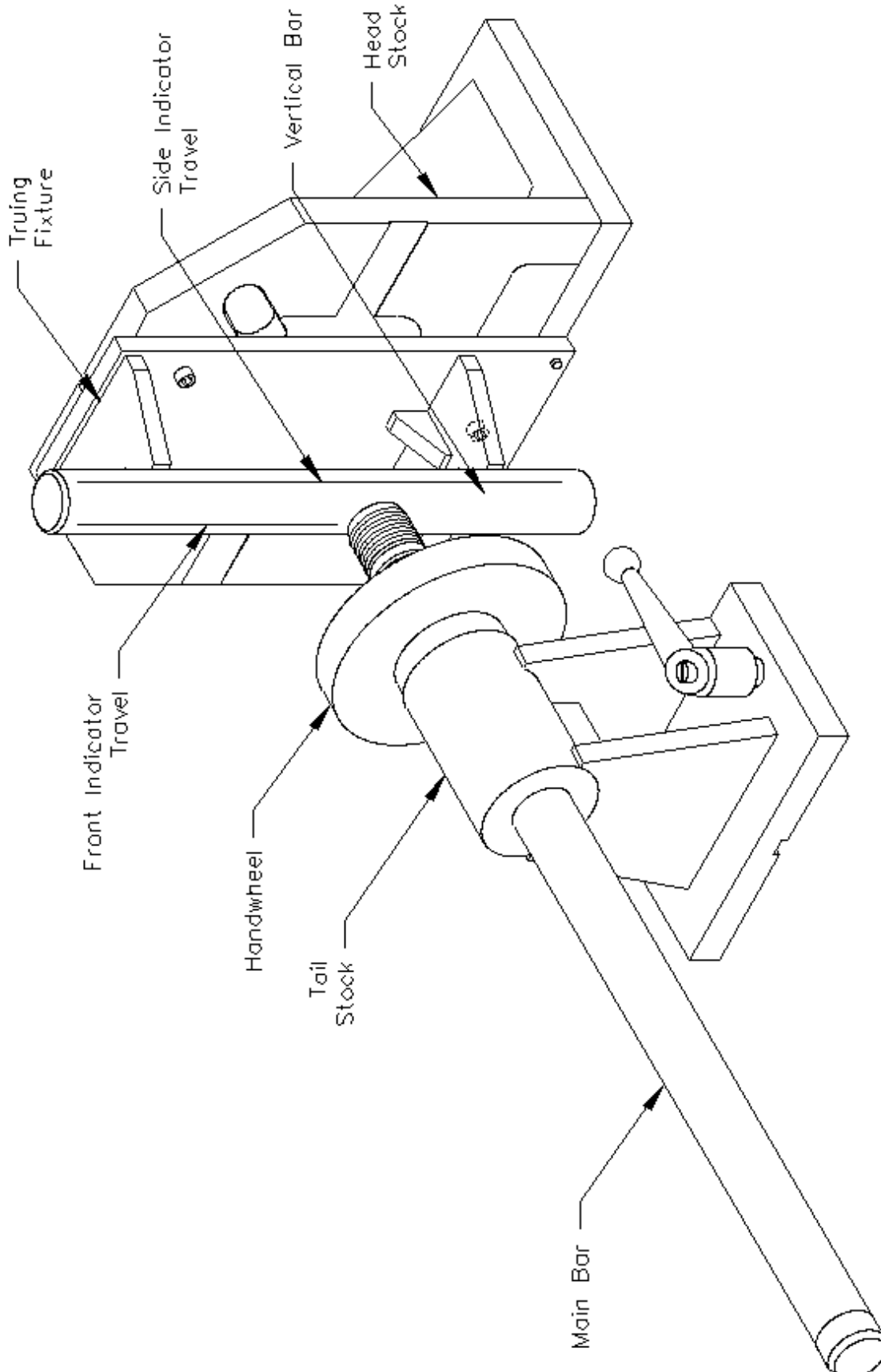

- 13) Loosen the Handwheel and remove the Vertical Bar.
- 14) Loosen the Tail stock and slide it to the right hand side of the machine table.
- 15) Select the correct Main Bushing for the block you are machining from the table in the Options section of this manual. Install the Main bushings as shown in the Performance Fixture earlier in this section.
- 16) Using a slow travel hoist position the block between the Head stock and tail stock with the Main Caps facing the Head stock as shown.
- 17) Slide the Vertical Bar into the Main bushings from the top. You will want to put a spacer on the table below the Vertical Bar so the bar does not go below the top V on the Truing fixture
- 18) Slide the towards the Head stock so that the Main Vertical Bar come to rest in the Vs on the truing fixture.
- 19) Slide the Tail stock up to the block and insert push plate as shown.
- 20) Tighten down the Tail stock.
- 21) Turn the Handwheel until the push plate has enough tension on it to keep the block from moving.

The block and fixture are now locked in place and ready for machining.

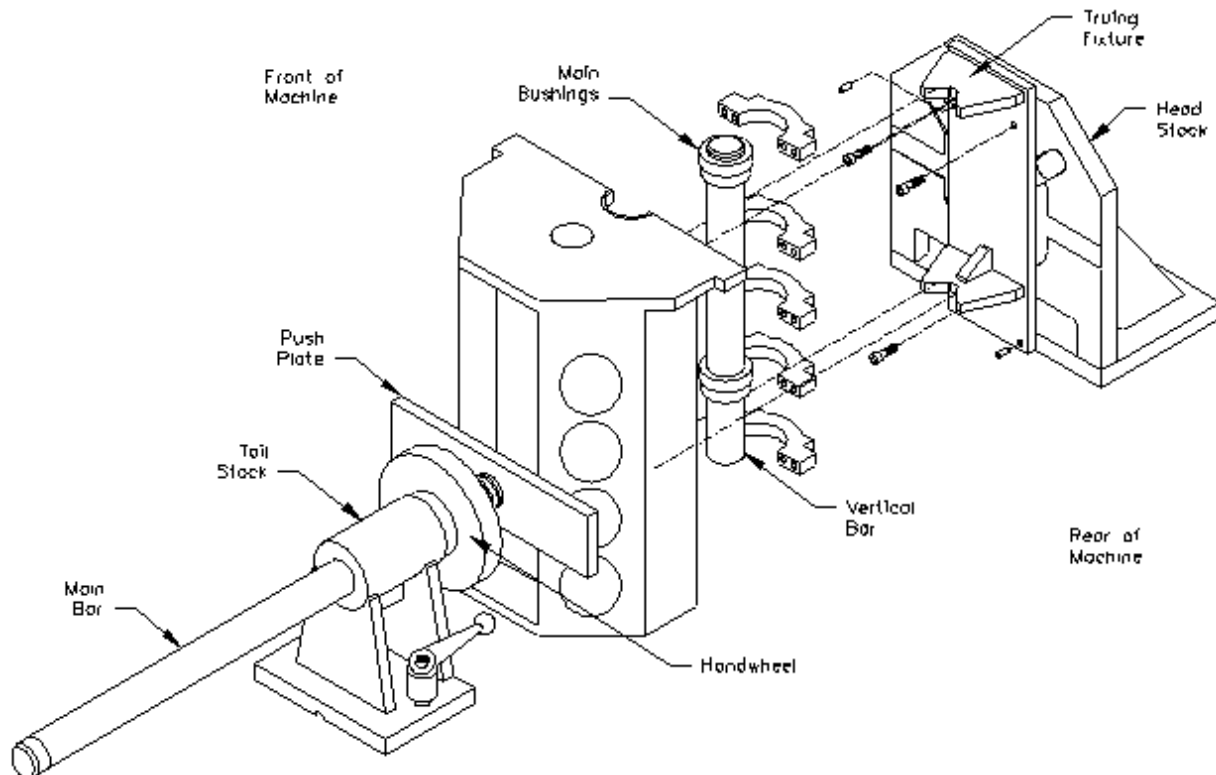

Block End Truing Fixture 650-3-30 when used with Cam Boring

When using the End truing Fixture for Cam Boring you will also need tooling package 650-3-43A

- 1) Use the same set up and line up procedure as with the standard End Truing Fixture discussed earlier in this section.
- 2) Place the Cam Spacer in the middle T-slot of the machine bed along with T-Nut and Bolt.
- 3) Select the correct Cam Bushing for the block you are going to be machining from the table in the Option section of this manual.
- 4) Place the Cam Bushing over the Cam Spacer. This will put the Cam and Main in-line and on center with the Fixturing.

The block and fixture are now locked in place and ready for machining.

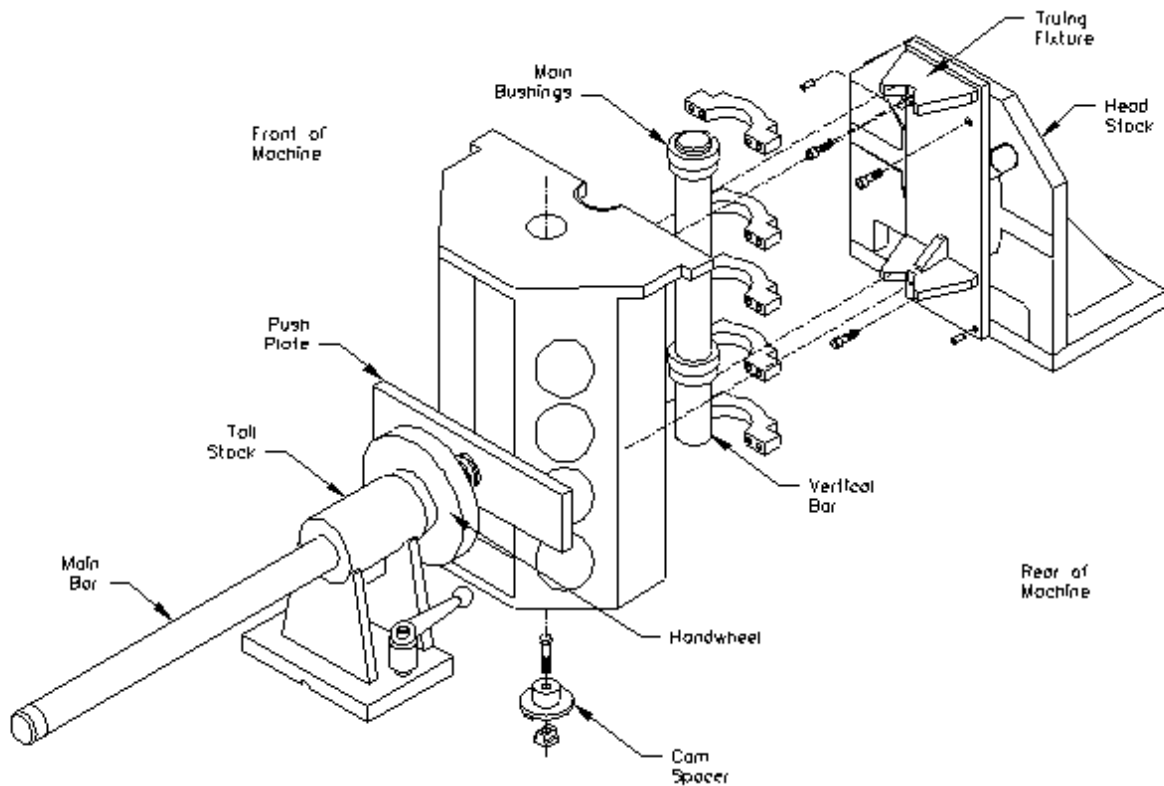

Cam Tunnel Boring

Place two T-Nuts in the outside keyway (closest to operator).

Mount block onto machine bed, as shown below with the right most cylinder hanging off the machine bed.

Place threaded rod through the first and third bores and thread into T-Nuts.

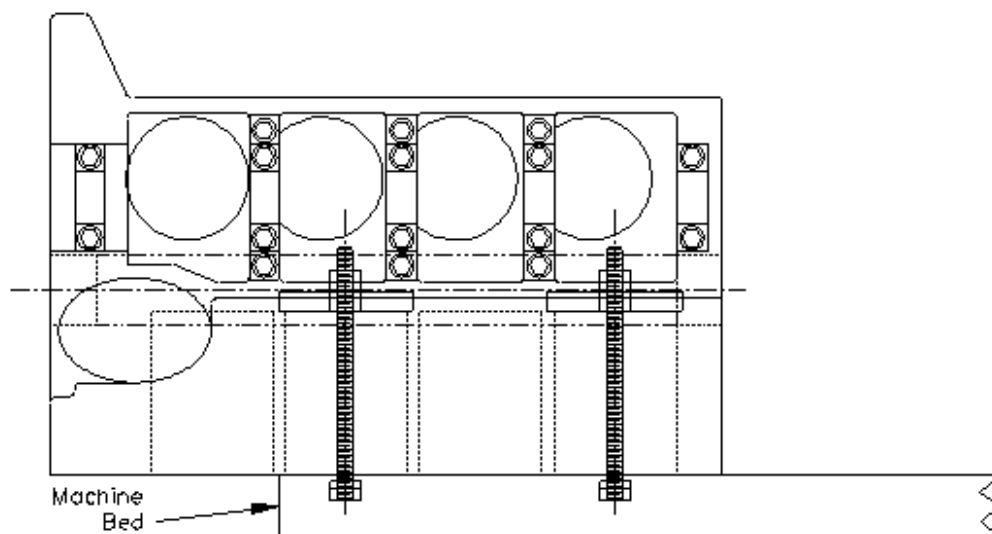
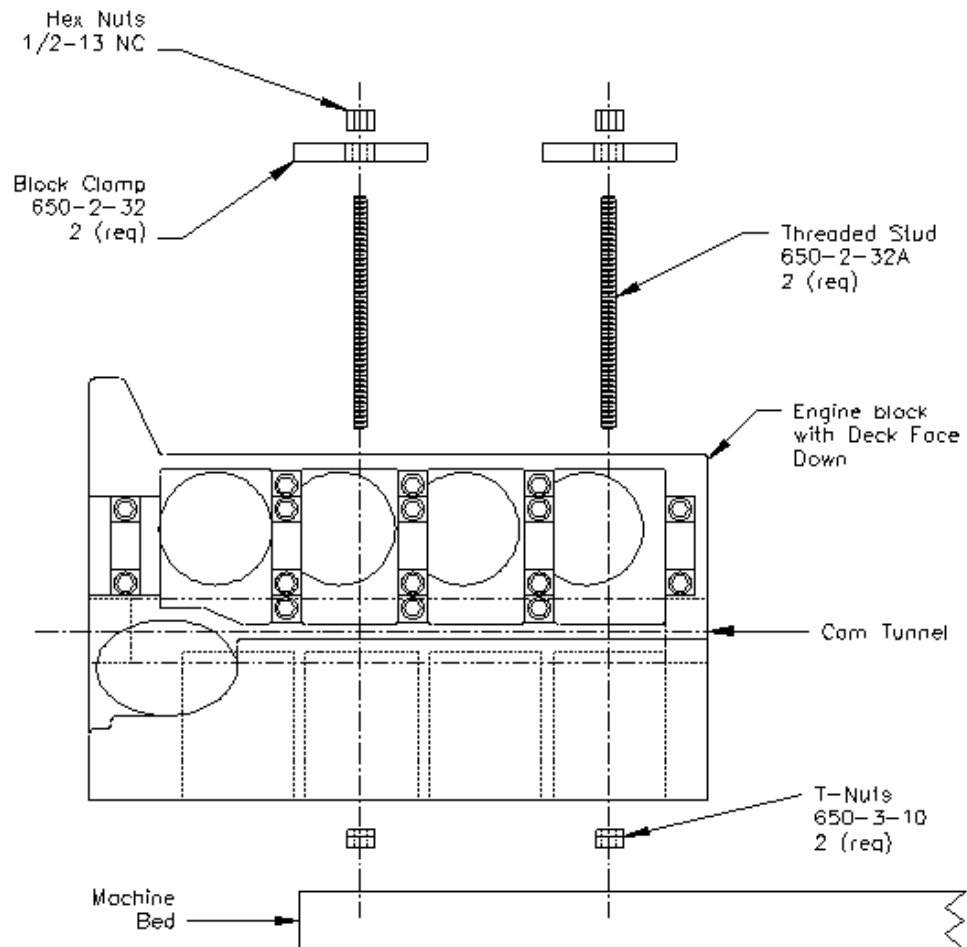

Screw the supplied 1/2-13 NC nuts on to the threaded rod and snug them up. Do not tighten them all the way at this point.

Attach a magnetic base indicator to the spindle and run it along the upper pan rail to get it relatively straight. It does not need to be perfectly straight because a double flex coupling is used.

Tighten the 1/2-13 nuts down.

The block and fixture are now locked in place and ready for machining.

650-3-20A Pan Rail Wedge Fixture

Installation and Operation

The 650-3-20A Pan Rail Wedge Fixture is used with the Performance fixture to set the correct cylinder bank angle for milling and boring operations. This fixture positions the block using the pan rail to set this angle. Both V-blocks and Y-blocks, as well as overhead cam blocks can all be set using this fixture.

Mounting

The pan rail fixture is mounted to the machine table between the head stock and tail stock of the performance fixture. Locate the fixture approximately centered between two of the main bearing caps. The key attached to base locates to the center keyway of the table. Once positioned, tighten the (2)(MF-150) hex bolts to secure. Choose the correct wedge for the block being machined from the list below:

650-3-23H Tall 30 deg. Wedge – 60 deg. V-blocks

650-3-23G Tall 45 deg. Wedge – 90 deg. V-blocks

650-3-23B Short 30 deg. Wedge – 60 deg. Y-blocks

650-3-23A Short 45 deg. Wedge – 90 deg. Y-blocks

These wedges can be flipped to face angled surface toward front or rear, depending on which bank of the block will be machined first. Mount the wedge to the fixture by sliding the keyhole over the shoulder screw in the 650-3-24 support plate. Turning the knob clockwise moves the wedge towards the operator, counterclockwise moves the wedge away from the operator. Operate the knob to move the wedge away from the block for loading.

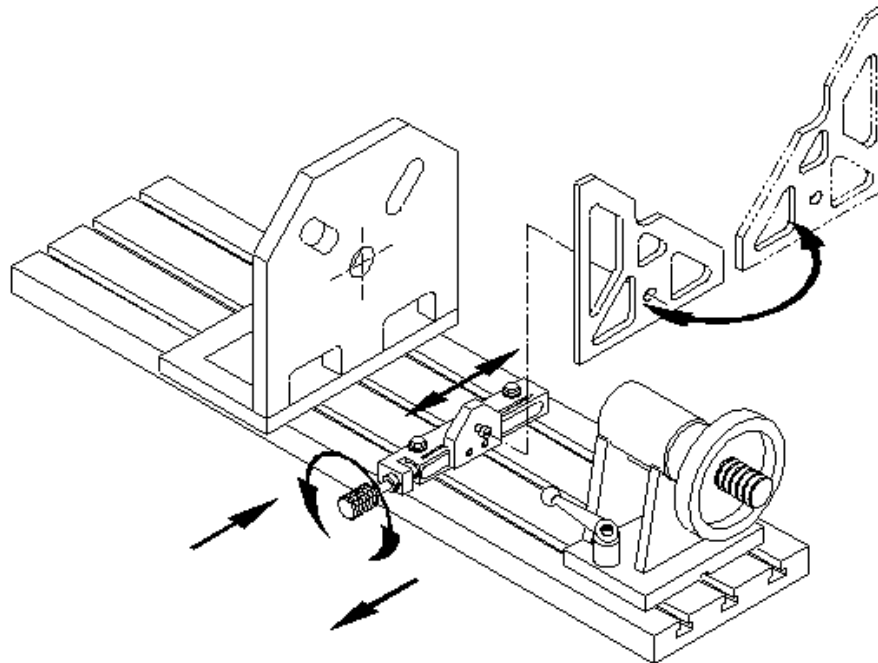

Loading the block

Note: for this fixture to work properly and with accuracy the block pan rails must be clean, smooth, and free of burrs. Burrs, dirt, and gasket material left of the pan rails will not let this fixture perform correctly. Install the wedge on the support plate with the angled surface facing the pan rails. Turn the knob to move support plate and wedge away from the centerline of the fixture to allow room to install the block in the fixture. Load the block with the bank you wish to machine approximately in position. Turn knob to bring wedge up to contact the pan rail. Once contacted, keep turning the knob until the wedge contacts both pan rails. At this point, the wedge should make firm contact with both the pan rails and the table. This contact can be checked with shim at both pan rails and front and rear at bottom of the wedge. Now the operator can tighten the performance fixture and proceed with machining. Note: this fixture is designed to position the block, not hold the block. Failure to tighten the fixture could result in block movement, causing possible block and/or machine damage and operator injury.

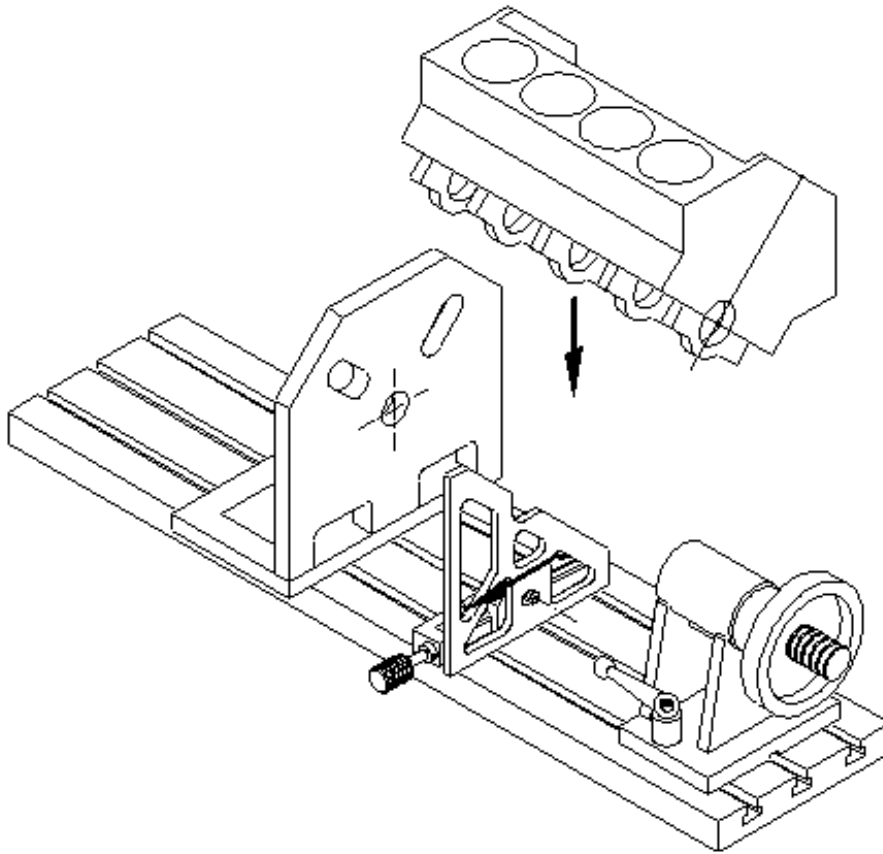

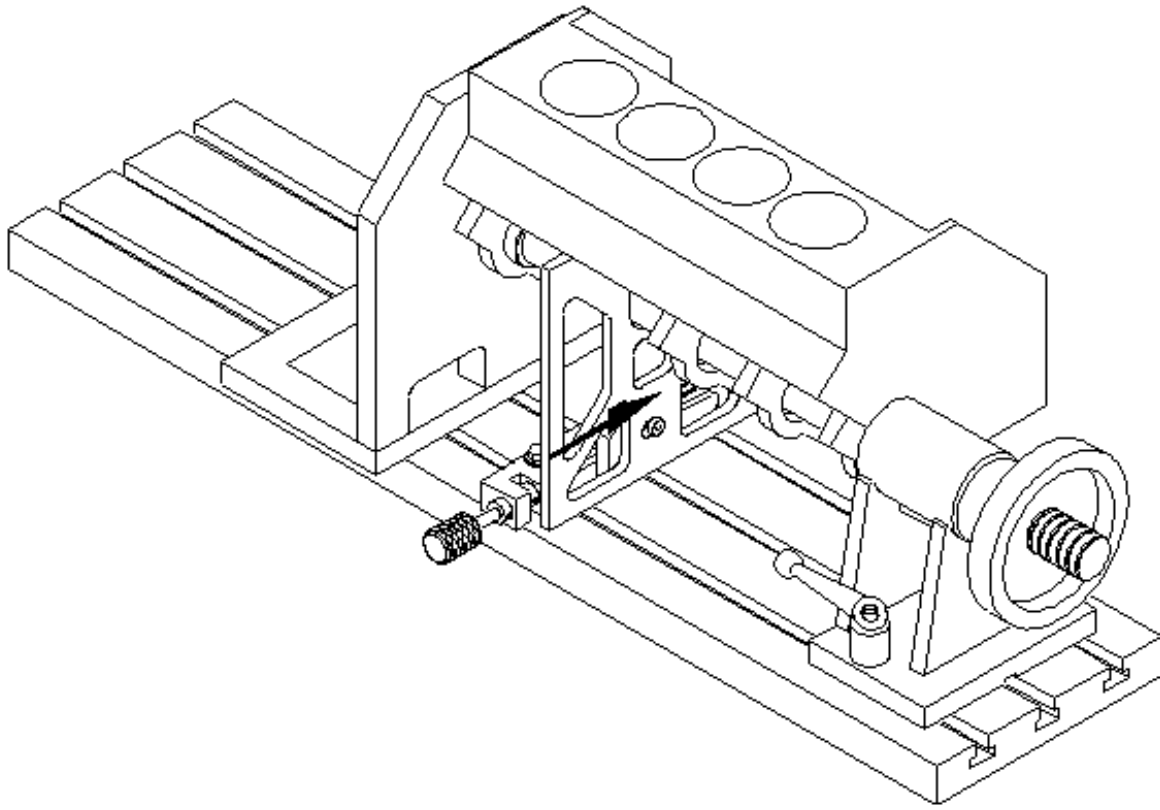

Switching Banks

After machining the first bank, clear chips away from the fixtures moving parts, especially around the contact surfaces of the wedge. Turn the knob to move the wedge away from the pan rails. Move the support plate away far enough to disengage the wedge from the shoulder screw. Remove the wedge from the support plate. Loosen the block and rotate to the other bank, again, approximately in the correct position. Turn the knob to position the support plate to install the wedge, turned around to again face the angled surface to the pan rails. Make sure the contact surfaces of the wedge are clean and free of chips. Turn the knob to move the wedge into contact with the pan rails, and continue until full contact with pan rails is made. Full contact can be checked with shim at both pan rails and front and rear at bottom of the wedge. Tighten the performance fixture and proceed with machining.

V6/V8 Manual Fixture Assembly 502-1-72H

Place parallels 650-3-34 on Machine bed 10 inches apart and secure with T-Nut and Hex bolts that are provided. The keys on the bottom of the parallels go in the back Key Way.

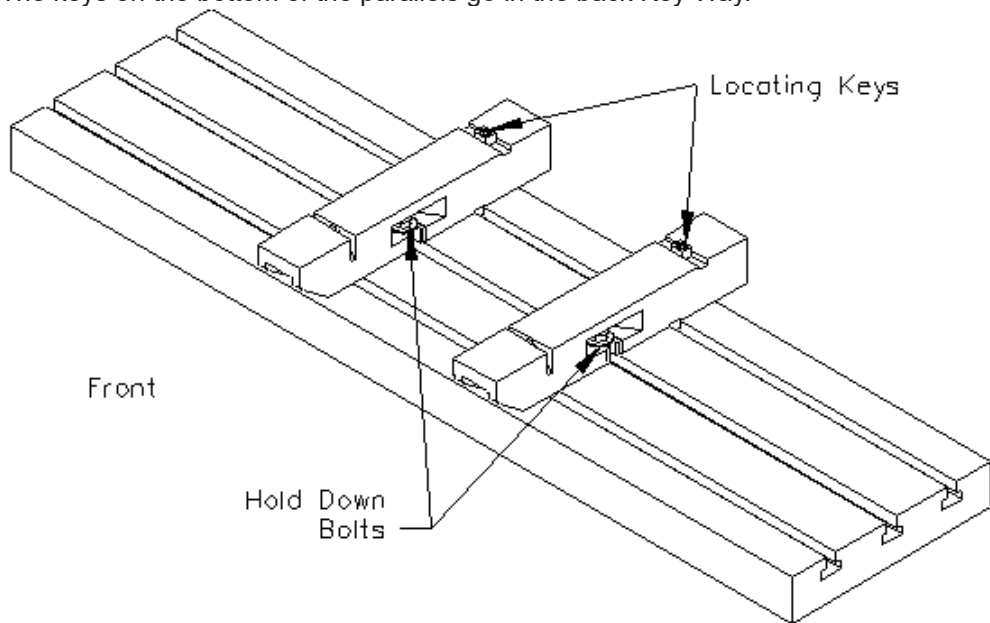

Select the 60 or 90 degree position for the fixture. Using a slow moving hoist, set the V6/V8 fixture onto the parallels.

Push the V6/V8 fixture back on the parallels until the keys in the top of the parallels line up to the machined sections on the rear of the V6/V8 fixture.

Use the supplied Socket Head cap Screw and T-Nut to secure the fixture in place.

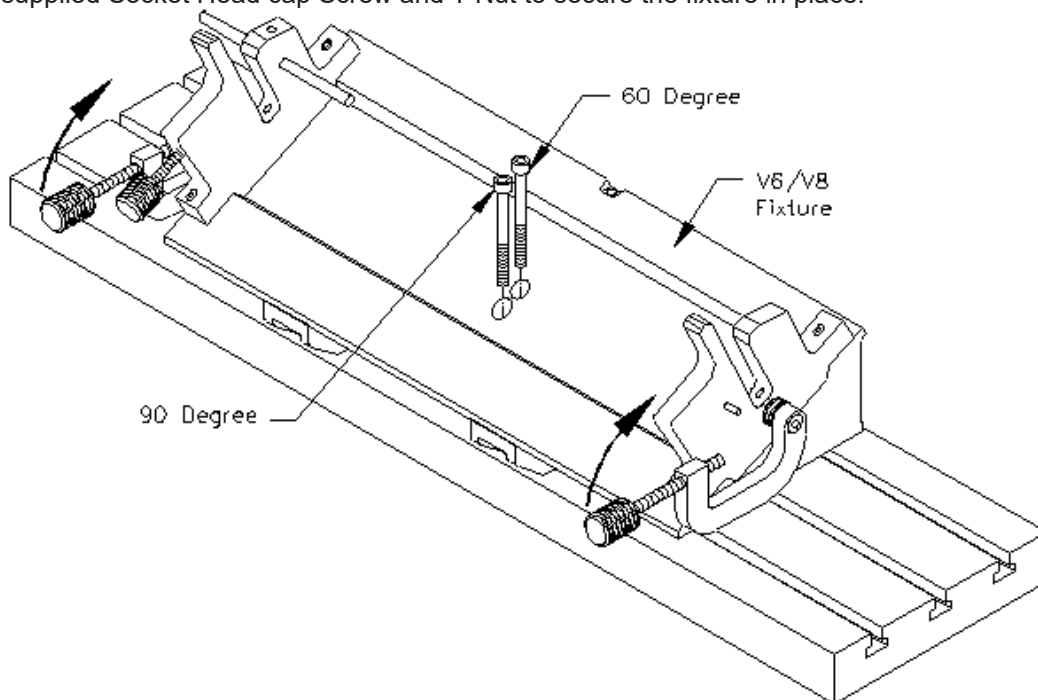

Decide if the Picture Frame or the 1" X 3" will need to be used.

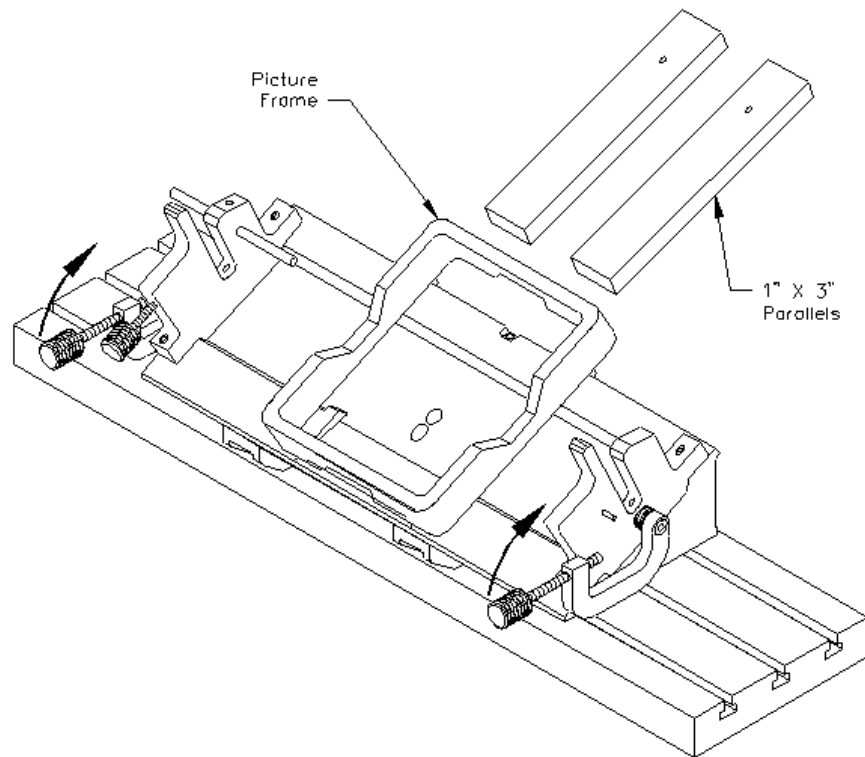

Slide the Locator Bar through the Mains of the block.

Lower the block with the Locator Bar installed into the V6/V8 fixture. Clamp the Locator Bar with the screw in clamps.

For a more detailed description on properly using and adjusting the V6/V8 fixture refer to the Manual V6/V8 Combination Fixture 502-1-72H in the Optional Equipment Parts Manual located on the manual CD.

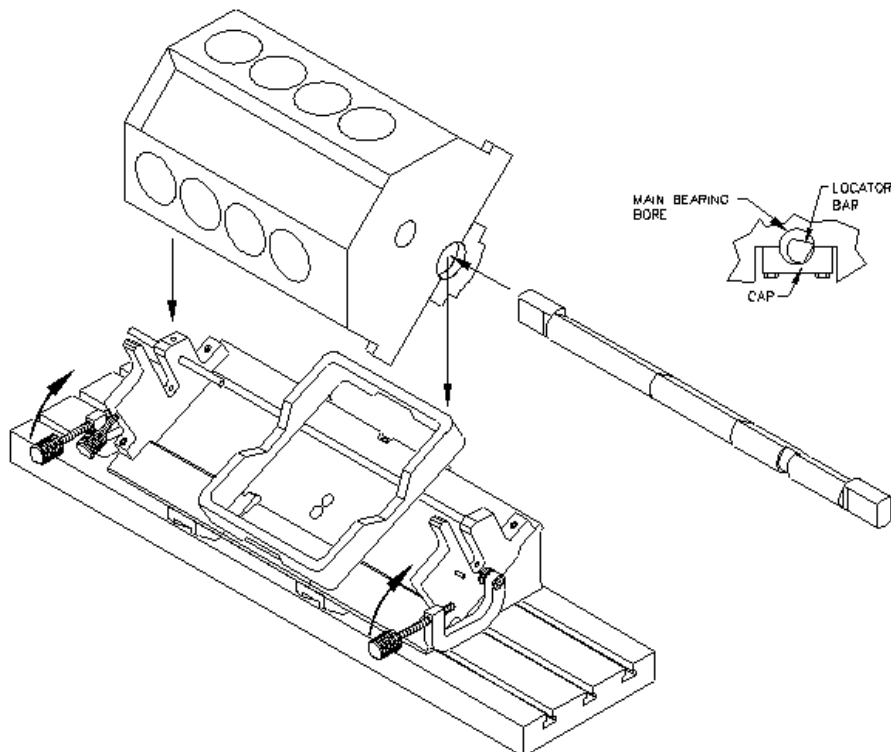

650-3-59 Auto Performance Fixture

The 650-3-59 Auto performance fixture is designed to quickly and accurately fixture v-style engine blocks for boring, surfacing, and other assorted machining operations. This fixture consists of an indexing headstock and an extending tailstock. This fixture is controlled with on screen commands on the F69 series machines. Locator sets are available to fit specific blocks and provide quick change over between different block styles. As with any precision tooling, careful machine set up and block preparation are critical to consistent accuracy and quality work.

Mount the indexer unit to machine.

The indexer unit for this fixture can be lifted using the supplied lift eye on top of the indexer. This eye can stay on the indexer in use. The indexer should be positioned on the left end of the machine table with the keys on the bottom of the 650-3-62Q riser plate in the center keyway.

Push the indexer back so the keys are against the backside of the center keyway of the machine table and tighten (4) mounting bolts. Use an indicator to check 650-3-62B faceplate for straightness both vertically and horizontally.

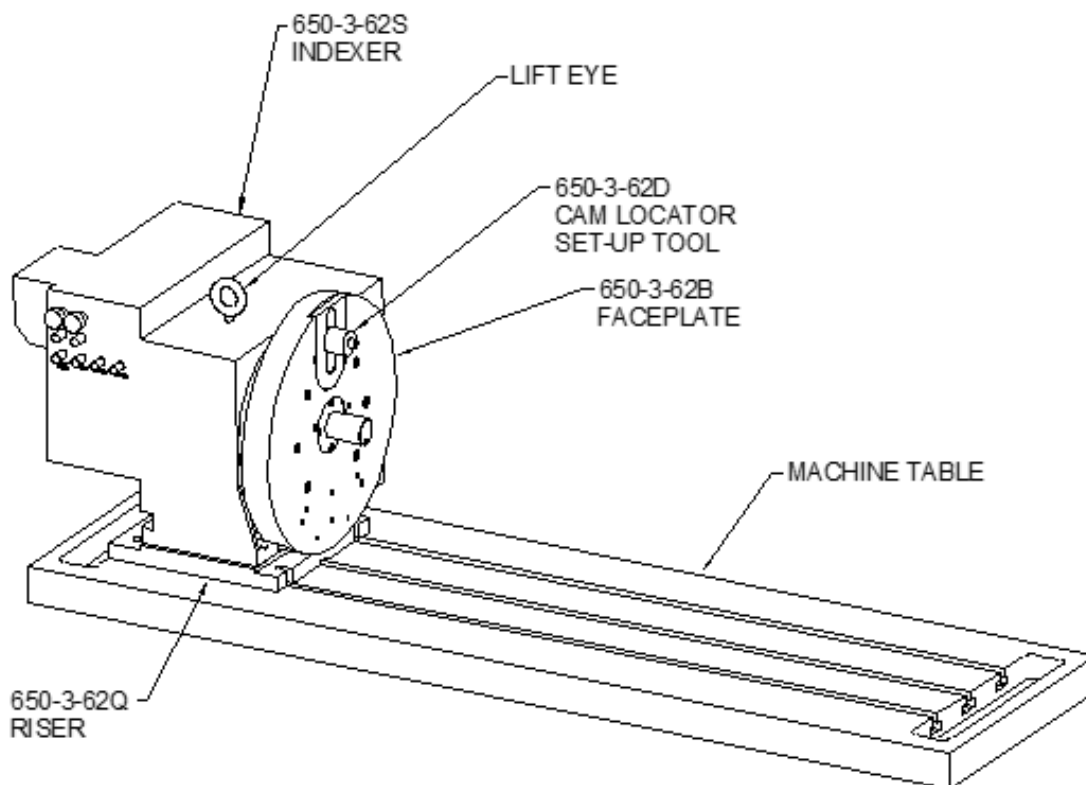

The 650-3-62D cam locator set-up tool should be installed on the indexer from the factory. This tool is used to check the angle '0' of the indexer. The diameter of this tool is the same diameter as the shaft on the 650-3-62H faceplate pinion. With the indexer set to 0 degrees these two shafts should be aligned vertically. An indicator can be used to check this. With the two shafts aligned vertically, the flat machined on the top of the 650-3-62B faceplate should indicate 0. The number stamped on the machined flat is the exact distance from the flat to the headstock centerline. The two flats milled at 45 degrees to each side of this central flat are set to the same distance from centerline.

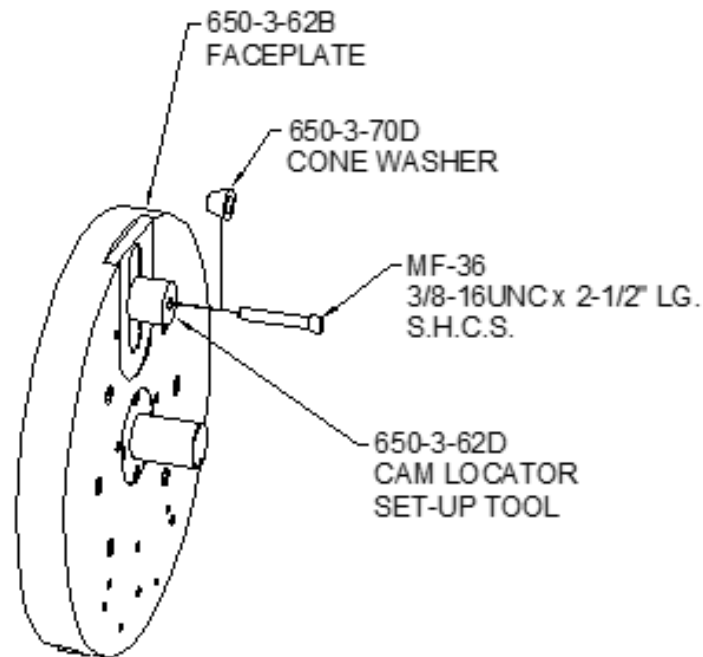

Mount the tailstock unit onto machine.

The tailstock can be lifted using the supplied 502-3-13 lift eye. Note: the lift eye has (2) 1/2-13unc nuts attached to it to prevent threading the lift eye too deep into the housing and contacting the 650-3-61G piston tube. Do not remove these nuts or substitute a longer thread as this will damage precision parts of this assembly. After moving the tailstock into position remove the lift eye and replace it with 650-3-61S 1/2-13 x 5/8" long socket button head screw to keep contamination out of the housing.

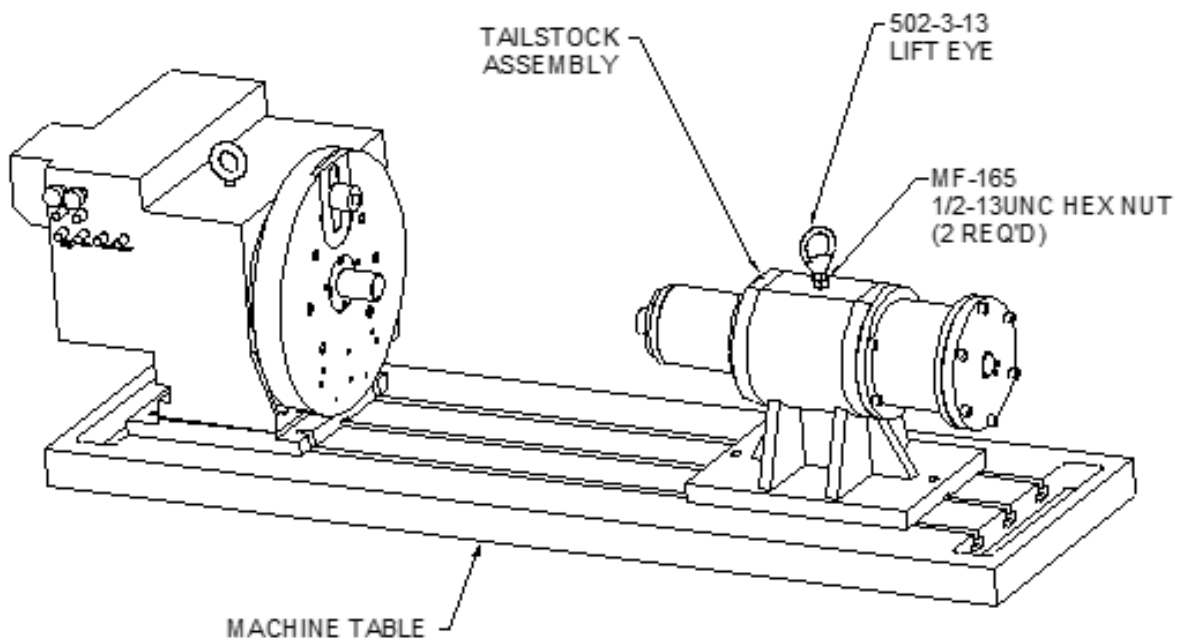

Install 650-3-61T alignment tool assembly to the pinion shaft of the indexer unit. Slide the tailstock up to place the 650-3-61H piston cap nose into the alignment tool. At this point the keys of the tailstock should be against the back of the machine table center keyway. When moving the tailstock to accommodate different block sizes the keys must be pushed against the keyway each time to ensure alignment before tightening the (2) mounting bolts. Remove the alignment tool assembly and place aside for future checking of alignment.

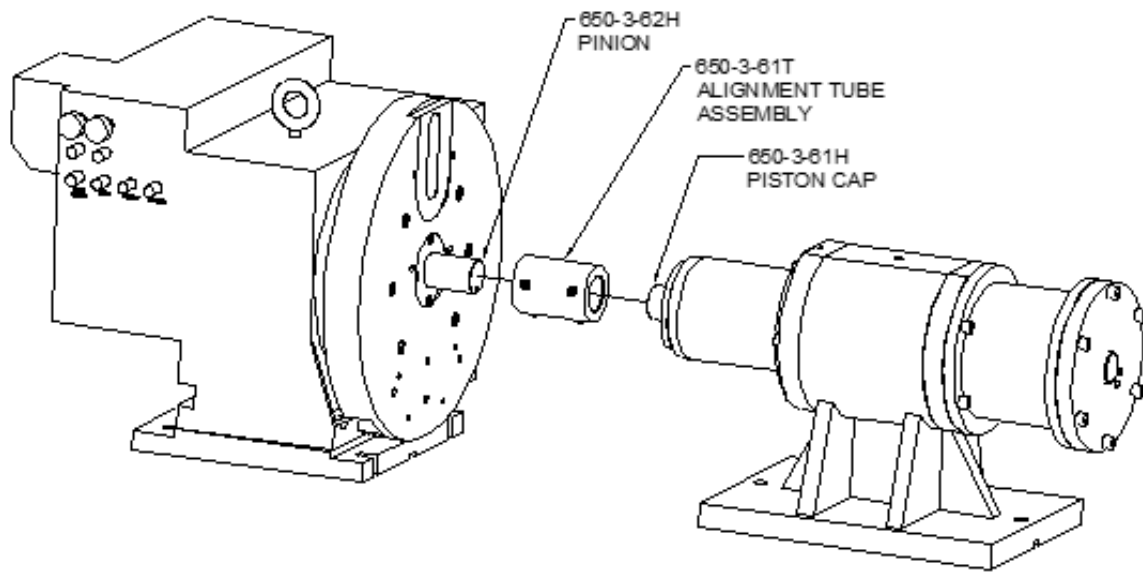

Using the 4th Axis Fixture

The 650-3-62D cam locator set-up tool should be installed on the indexer from the factory. This tool is used to check the angle '0' of the indexer. The diameter of this tool is the same diameter as the shaft on the 650-3-62H faceplate pinion. With the indexer set to 0 degrees these two shafts should be aligned vertically. An indicator can be used to check this. With the two shafts aligned vertically, the flat machined on the top of the 650-3-62B faceplate should indicate 0. The number stamped on the machined flat is the exact distance from the flat to the headstock centerline. The two flats milled at 45 degrees to each side of this central flat are set to the same distance from centerline.

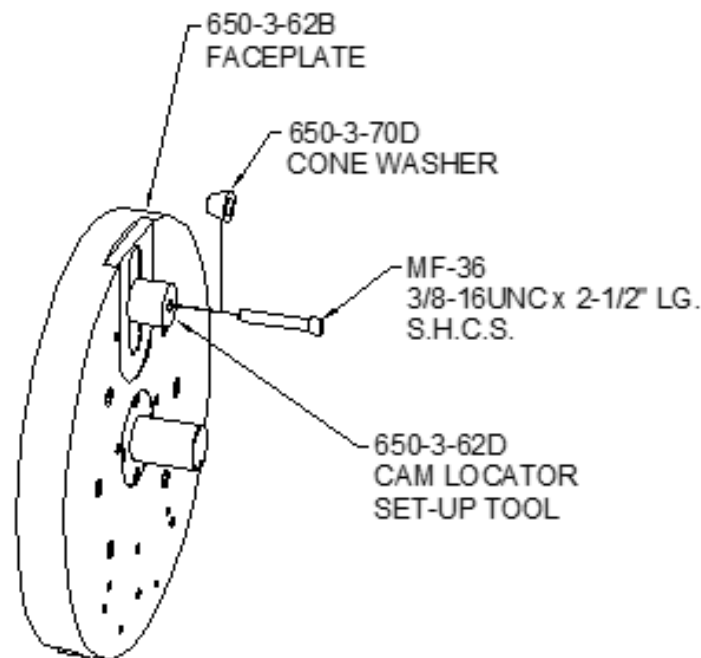

Locators: This fixture requires the use of locator sets, sized to fit individual engine blocks. These sets consist of (1) cam bearing bore locator, (1) #5 main bearing bore locator, and (1) #1 main bearing bore locator.

Main bearing bore locators: The #5 main locator is sized to fit onto the 650-3-62H faceplate pinion with the tapered end facing out. This locator is retained on the pinion by the MF-86 button head screw in the pinion. The #1 main locator is sized to fit onto the 650-3-61H piston cap of the tailstock with the tapered end facing out. This locator is also retained by an MF-86 button head screw.

Expanding cam bore locator: The cam bore locator is sized to fit into the 650-3-62B faceplate. To load the specific locator: remove the MF-36 3/8-16UNC cap screw and the 650-3-62D setup tool from the faceplate. The setup tool should be set aside for checking indexer '0' in the future. Install the cam locator with its socket fitting into the slot in the faceplate. The 650-3-70D cone washer is installed into the mating countersink in the locator, and held in by re-installing the 3/8-16UNC cap screw. This cap screw threads into the 650-3-62V cam locator nut that is trapped in the 650-3-62B faceplate. Tighten the cap screw just enough to hold the locator in the desired location in the slot.

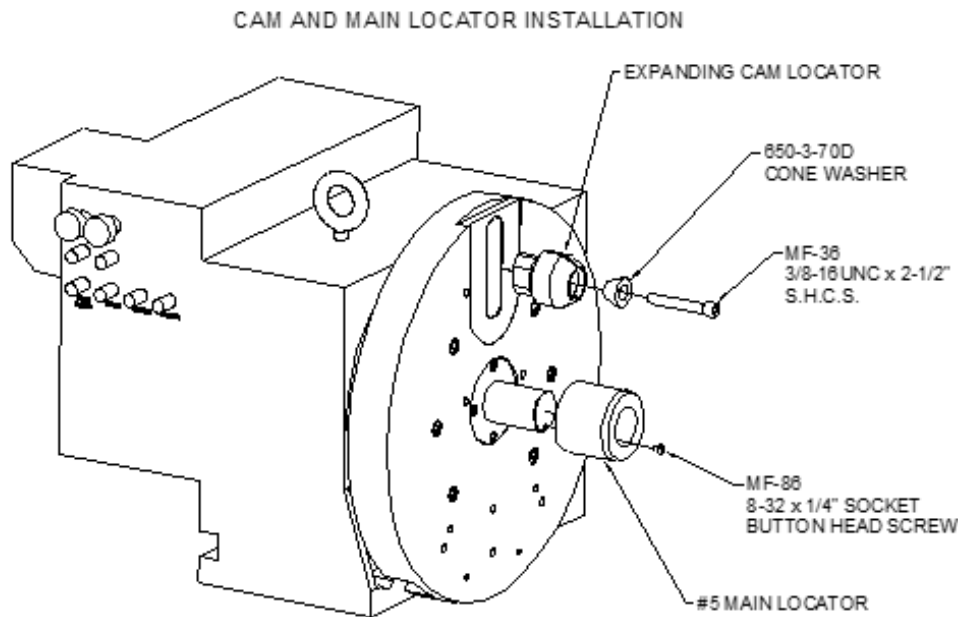

Loading an engine block

This fixture requires the main bearing bores, the rear cam bearing bore, and the transmission mounting surface of the engine block be clean and free from nicks, dings, and foreign particles. Failing to ensure this will result in poor performance of your fixture.

The tailstock must be positioned to allow space to install the engine block, but still be close enough to clamp the block within the 6" of stroke allowed by the tailstock piston. Approximately 3-1/2" of the stroke will be used to take up the required length of the locators, leaving approximately 2-1/2" of room to position the tailstock.

Generally, measure the overall length of the engine block and add 1". This will be the space to leave between the pinion noses of the headstock and tailstock with the tailstock piston retracted. Example: a 20" long engine block will require the pinion noses to be 21" apart. This will leave 1/2" of room on each end of the engine block for loading and still be within the stroke length of the tailstock.

After setting the distance between the pinion noses, tighten the tailstock down with its keys pushed back against the center keyway of the table.

Measure the distance between the centerlines of the main and cam bores of the block. Slide the adjustable cam locator to be equal to this distance. Lightly tighten the MF-36 cap screw to keep the cam locator in place.

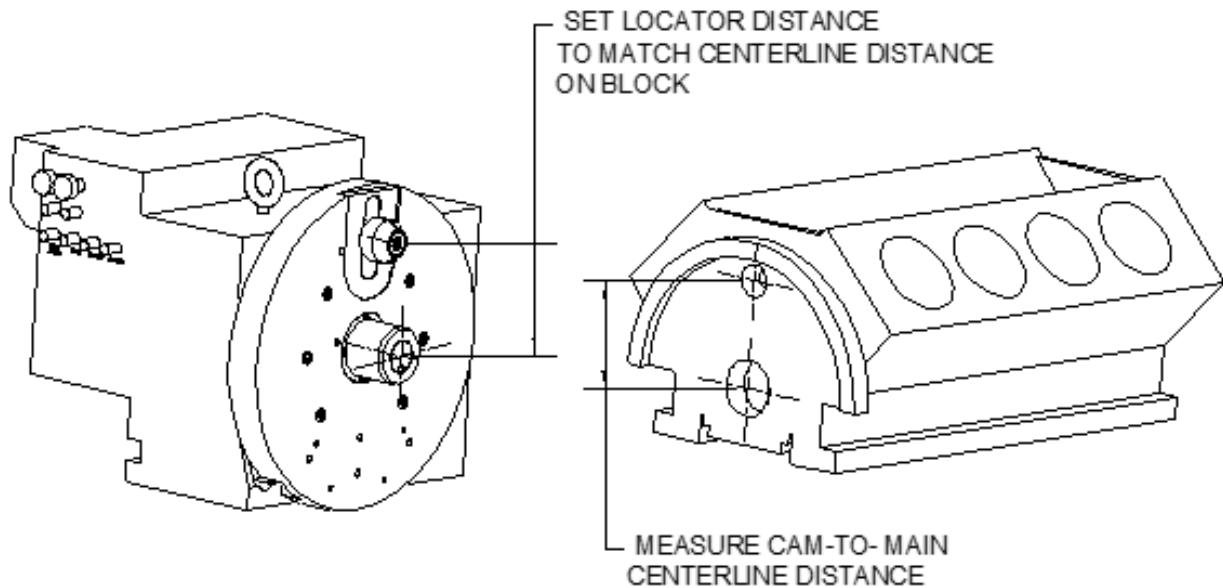

Using a hoist, load the engine block down between the pinions with the bell housing surface facing the headstock. Slide the block's main bore over the #5 main locator on the headstock and position the block to slide the cam bore over the cam locator. Tapers on the outside of both locators will aid in positioning. Push the block flush up against the faceplate and activate the 'light extend'. This will extend the tailstock piston with limited pressure to locate the block on the tailstock. **CAUTION:** keep fingers and all other objects out of the path of the tailstock piston. Even with limited pressure, severe injury could occur if this rule is not followed. If desired, a hex socket and long extension can reach through the cam bores from the front of the block and be used to tighten the cap screw holding the cam locator in place. The 650-3-70D cone washer will expand the cam locator to provide a tighter fit on the cam bore, further centering the block on the indexer '0'. Once the block is located properly, full tailstock pressure can be applied after rotating the indexer to the desired angle.

After machining is complete, unload the block in reverse order. Loosen the cap screw on the cam locator to release pressure on the cam bore of the block. Position the hoist to hold block and retract the tailstock. Slide the block off the faceplate and locators to remove.

Readjusting tailstock piston alignment

Checking for tailstock alignment may be required after heavy use or after a crash has occurred. The first step is to check all possible variables before making adjustments.

Headstock: make sure the headstock is pushed back with the keys against the back of the center keyway of the machine table. Tighten the (4) bolts to secure the headstock to the table and check faceplate for squareness.

Tailstock: the tailstock also must be pushed back with the keys against the back of the center keyway of the machine table.

With both units tightened down as described above, an indicator can be used to check the alignment between the two pinions both vertically and horizontally. If the alignment is out more than .001 in either direction an adjustment must be made.

The headstock pinion should be checked for runout. With an indicator placed on the 650-3-62H pinion, rotate the indexer. The runout here should be no more than .0005. Runout of this pinion can be adjusted by loosening the (6) MF-33A 3/8-16 cap screws holding the faceplate to the indexer and tapping the faceplate until the pinion runs true. Retighten the (6) cap screws. Check both pinions with an indicator again for alignment. If still not aligned within specs the tailstock will need adjustment.

Begin with the tailstock piston retracted. Remove the 650-3-61K cushion from the tailstock piston cap. Note the timing of the 650-3-61H piston cap relative to the piston tube to reassemble in the same configuration. Remove the (4) MF-5 cap screws from the 650-3-61H piston cap. If the cap does not slide out, the MF-5 cap screws can be threaded into the four tapped holes of the cap and evenly tightened to push the cap out of the 650-3-61G piston tube. Beneath the piston cap is the 650-3-61J nose plate which is attached to the piston of the 650-3-61E stroking cylinder with a MF-172 1/2-20 hex nut. Activating the tailstock to light extend should push the nose plate out of the piston tube. Using the flats on the cylinder piston to keep it from turning, removed the 1/2-20 hex nut. Slide the nose plate off of the cylinder piston. Remove the (4) MF-34 3/8-16 x 2" long cap screws holding the 650-3-61C tailstock extension on. The tailstock extension with the stroking cylinder should slide out through the back of the housing.

Slide the piston tube to be centered in the tailstock housing. Reinstall the 650-3-61H nose plate in the piston tube. Remove 6247A retainer, 6248 wiper, 6249 felt compressor, and 6251 felt oiler from front of 6225A bearing carrier. Loosen 100-82-2B 8-32 brass tipped set screw in bearing carrier. Tighten 6223 spindle nut until piston tube will not slide by hand. Loosen the (6) MF-32 3/8-16 cap screws holding the 6225A carrier on the housing. Loosen the (6) MF-31 3/8-16 cap screws holding the 650-3-61F rear bushing on the housing.

Install the 650-3-61T alignment tube assembly over the pinion of the headstock. Slide the tailstock up to fit the tailstock pinion into the alignment tube. Tighten (4) setscrews on the alignment tube to lock the two pinions in alignment. Push the tailstock housing to the rear to contact the keys with the middle keyway of the machine table and tighten its two mounting bolts. Check the piston tube with an indicator across the top and the back on both ends for straightness. Tap on either the carrier or the rear bushing to adjust alignment. The piston tube should be straight within .0005 in both directions. Retighten the 3/8-16 cap screws holding both the carrier and the rear bushing. Loosen the tailstock mounting bolts. Loosen the (4) set screws of the alignment tube assembly and slide the tailstock back from the headstock. Push the tailstock back on the middle keyway and tighten the mounting bolts. Recheck alignment of the pinions with an indicator in both directions. Recheck the straightness of the piston tube with an indicator. If alignment is within specs, reassemble the tailstock as follows:

Loosen the 6223 spindle nut until the piston tube can be moved by hand applying about 40-50 lbs. of force. Tighten the 100-82-2B set screw to lock the nut in place. Remove the 650-3-61H piston cap. Reinstall the 650-3-61C tailstock extension with the stroking cylinder attached and lightly tighten its (4) mounting cap screws. The stroking piston cylinder should be sticking out the front of the piston tube. Reinstall the 650-3-61J nose plate and tighten the 1/2-20 nut to secure. Release the air pressure from the stroking cylinder and slide its piston back by hand into the piston tube until the nose plate contacts the bottom of the counterbore in the piston tube. Tighten the (4) cap screws holding the 650-3-61C tailstock extension on. Reinstall the 650-3-61H piston cap and 650-3-61K cushion.

Block Blueprint Dimensions

Specifications are accurate to the best of our knowledge and have been obtained from reliable sources. We provide no guarantee on dimensional accuracy. OEM specs change frequently and we are not notified, check with OEM to obtain specifications for a particular year of block.

Block Dimensions: Cylinder Bore Dimensions

Block Make & Model	Cylinder Bore Location Left Bank	Cylinder Bore Location Right Bank	Cylinder Bore Spacing	Cylinder Bank Offset	Cylinder Bore Center from Dowel Pin Location
Dimension From					
Chevy 302,305,307 327,350, 400	1. 2.40 front dowel 2. 6.80 3. 11.20 4. 15.60	1. 2.40 front dowel 2. 6.80 3. 11.20 4. 15.60	4.4	.880 offset	1.42
Chevy 396, 427	1. 2.24 front dowel 2. 7.08 3. 11.92 4. 16.76	1. 2.47 front dowel 2. 7.32 3. 12.15 4. 16.99	4.84		1.85
Chevy 454	1. 2.24 front dowel 2. 7.08 3. 11.92 4. 16.76	1. 2.47 front dowel 2. 7.32 3. 12.15 4. 16.99	4.84		1.85
Chevy LS1	1. 2.200 front dowel 2. 6.600 3. 11.00 4. 15.400	1. 2.200 front dowel 2. 6.600 3. 11.00 4. 15.400	4.4		2.2
Chevy SB 2	1. 2.40 front dowel 2. 6.80 3. 11.20 4. 15.60	1. 2.40 front dowel 2. 6.80 3. 11.20 4. 15.60	4.4	.880 offset	1.42
Ford 289,302,351W	1. 2.190 rear dowel 2. 6.570 3. 10.950 4. 15.33	1. 2.190 front dowel 2. 6.570 3. 10.950 4. 15.330	4.38		Left Bank 2.115/2.125 Right Bank 2.118/2.122
Ford 351C, 351M & 400	1. 2.190 rear dowel 2. 6.57 3. 10.950 4. 15.33	1. 2.190 front dowel 2. 6.570 3. 10.950 4. 15.330	4.38		Left Bank 2.120 Right Bank 2.120
Ford 390 & 427	1. 2.305/2.325 rear 2. 6.935/6.955 3. 11.565/11.585 4. 16.195/16.215	1. 2.305/2.325 front 2. 6.935/6.965 3. 11.565/11.585 4. 16.195/16.215	4.63		Left Bank 2.220 Right Bank 2.220

Block Make & Model	Cylinder Bore Location Left Bank	Cylinder Bore Location Right Bank	Cylinder Bore Spacing	Cylinder Bank Offset	Cylinder Bore Center from Dowel Pin Location
Dimension From					
Ford 428			4.63		
Ford 429 & 460	1. 2.45 rear dowel 2. 7.35 3. 12.25 4. 17.15	1. 2.45 front dowel 2. 7.35 3. 12.25 4. 17.15	4.9		
Ford 4.6 & 5.4			3.937		
Ford V10			3.937		
Chrysler 318,340,360	1. 4.02 rear dowel pan rail 2. 8.48 3. 12.94 4. 17.40	1. 3.14 rear dowel pan rail 2. 7.60 3. 12.06 4. 16.52	4.46	0.88	
Chrysler 383, 426 wedge	2.52 front dowel 7.32 12.120 16.92	2.52 front dowel 7.32 12.120 16.920	4.8		
Chrysler 426 Hemi, 440	2.52 front dowel 7.32 12.120 16.92	2.52 front dowel 7.32 12.120 16.920	4.8	9.5	
Chrysler V10 Iron					

Block Dimensions: Other Dimensions

Block Make & Model	Lifter Bore Angle	Lifter Bore Location Left Bank	Lifter Bore Location Right Bank	Crank Bore Diameter	Cam Bore Diameter	Cam Bore to Crank Bore Centerline	Deck Height
Dimensions From							
Chevy 302,305,307 327,350,400	41 degrees Int & Ex	1. 1.58 front dowel 2. 3.14 3. 6.16 4. 7.72 5. 10.38 6. 11.94 7. 14.96 8. 16.52	1. 1.48 front dowel 2. 3.04 3. 6.06 4. 7.62 5. 10.28 6. 11.84 7. 14.86 8. 16.42	small journal 2.4906/2.4916 late model journal 2.6406/2.6416 400 sbc 2.8406/2.8416	1st Journal 2.0190/2.0210 5th Journal 2.009/2.0110	4.521	9.0315
Chevy 396,427	45 degrees Int. 38 degrees Ex. Caution Dart & World Blocks are 38.75 degrees	1. 1.34 front dowel 2. 3.14 3. 6.18 4. 7.98 5. 11.02 6. 12.82 7. 15.86 8. 17.66	1. 1.57 front dowel 2. 3.37 3. 6.41 4. 8.21 5. 11.25 6. 13.05 7. 16.09 8. 17.89	2.9365/2.9375	1st Journal 2.1395/2.1405 5th Journal 2.1295/2.1305	5.15	9.8
Chevy 454	45 degrees Int. 38 degrees Ex. Caution Dart & World Blocks are 38.75 degrees	1. 1.34 front dowel 2. 3.14 3. 6.18 4. 7.98 5. 11.02 6. 12.82 7. 15.86 8. 17.66	1. 1.57 front dowel 2. 3.37 3. 6.41 4. 8.21 5. 11.25 6. 13.05 7. 16.09 8. 17.89	2.9365/2.9375	1st Journal 2.1395/2.1405 5th Journal 2.1295/2.1305	5.15	9.8
Chevy LS1		1. 1.4004 ft dowel 2. 3.227 3. 5.800 4. 7.627 5. 10.200 6. 12.027 7. 14.600 8. 16.427	1. 1.173 ft dowel 2. 3.00 3. 5.573 4. 7.400 5. 9.973 6. 11.800 7. 14.373 8. 16.200	2.750/2.751	2.3276/2.3295 1st & 5th Journal	4.885	9.235/9.245

Block Make & Model	Lifter Bore Angle	Lifter Bore Location Left Bank	Lifter Bore Location Left Bank	Crank Bore Diameter	Cam Bore Diameter	Cam Bore to Crank Bore Centerline	Deck Height
Dimension From							
Chevy SB 2		1. 1.518 front dowel 2. 3.353 3. 5.918 4. 7.753 5. 10.340 6. 12.152 7. 14.740 8. 16.552	1. 2.306 front dowel 2. 4.140 3. 6.706 4. 8.540 5. 11.127 6. 12.940 7. 15.527 8. 17.340	1st Journal 2.0190/2.0210 5th Journal 2.009/2.0110	4.521		
Ford 289,302,351W	41degrees, 15 min. Intake & Exhaust	1. 1.375 Rear dowel 2. 3.105 3. 5.755 4. 7.485 5. 10.135 6. 11.865 7. 14.515 8. 16.245	1. 1.375 front dowel 2. 3.105 3. 5.755 4. 7.485 5. 10.135 6. 11.865 7. 14.515 8. 16.245	2.441/2.442 289/302 3.192/3.1930 351W	1st journal 2.2041/2.2051 5th journal 2.1440/2.1450	4.804/4.807	8.206
Ford 351C, 351M & 400	41 degrees 15 min Intake & Exhaust	1. 1.375 rear dowel 2. 3.105 3. 5.755 4. 7.485 5. 10.135 6. 11.865 7. 14.515 8. 16.245	1. 1.375 front dowel 2. 3.105 3. 5.755 4. 7.485 5. 10.135 6. 11.865 7. 14.515 8. 16.245	2.941/2.942	1st journal 2.2495/2.2505 5th journal 2.1440/2.1450	5.0435/5.0465	351M/400 10.292/10.302 351C 9.206
Ford 390 & 427	41 degrees 15 min Intake & Exhaust	1. 1.145/1.165 rear 2. 3.125/3.145 3. 5.775/5.795 4. 7.755/7.775 5. 10.745/10.765 6. 12.725/12.745 7. 15.375/15.395 8. 17.355/17.375	1. 1.145/1.165 front 2. 3.125/3.145 3. 5.775/5.795 4. 7.755/7.775 5. 10.745/10.765 6. 12.725/12.745 7. 15.375/15.395 8. 17.355/17.375	2.941/2.942	1st journal 2.3095/2.3105 5th journal 2.2495/2.2505	5.0475/5.0485	
Ford 428				2.941/2.942	1st journal 2.3095/2.3105 5th journal 2.2495/2.2505	5.044	10.17

Chrysler 318 Dimensions

Block	Cam Bore Center to Crank Bore Center Distance	Lifter Bore Angle	Cam Bore Dia	Crank Bore Dia
318	6.1215/6.1275	48deg or 59deg (All production small blocks are 59 degrees)	#1 2.1290 / 2.1305 #5 1.6915 / 1.6930	2.6925 / 2.6932

We have heard that these dimensions are the same for 318/340/360 but we have been unable to confirm.

Specifications are accurate to the best of our knowledge and have been obtained from reliable sources. We provide no guarantee on dimensional accuracy. OEM specs change frequently and we are not notified, check with OEM to obtain specifications for a particular year of block.

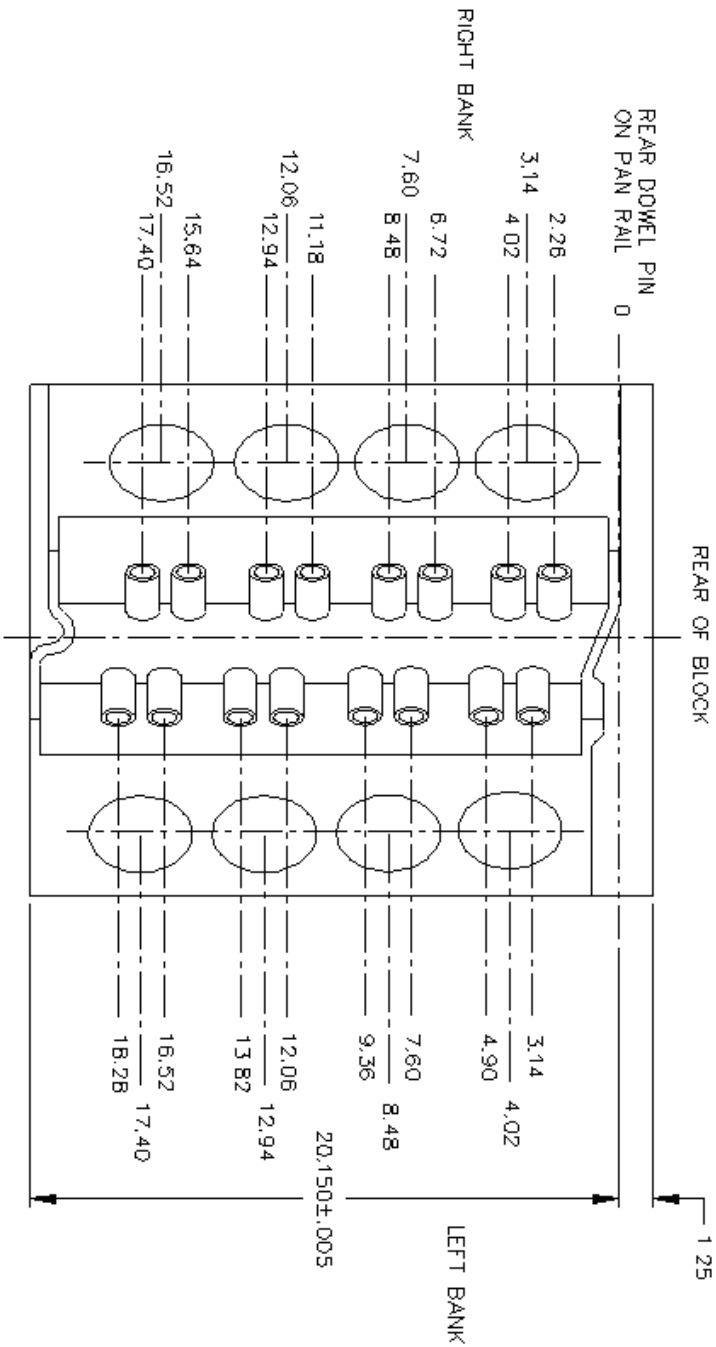

Chevrolet Big Block Dimensions

Block	Cam Bore Center to Crank Bore Center Distance	Lifter Bore Angle	Cam Bore Dia	Crank Bore Dia
Big Block Chev.	5.15	45 or 38 (Tall Deck)	#1 2.1395 - 2.1405 #5 2.1295 - 2.1305	2.9365 - 2.9375

Specifications are accurate to the best of our knowledge and have been obtained from reliable sources. (HP Books "Chevrolet Power" IZBN #1-55788-087-5 available through most book stores) We provide no guarantee on dimensional accuracy. OEM specs change frequently and we are not notified, check with OEM to obtain specifications for a particular year block.

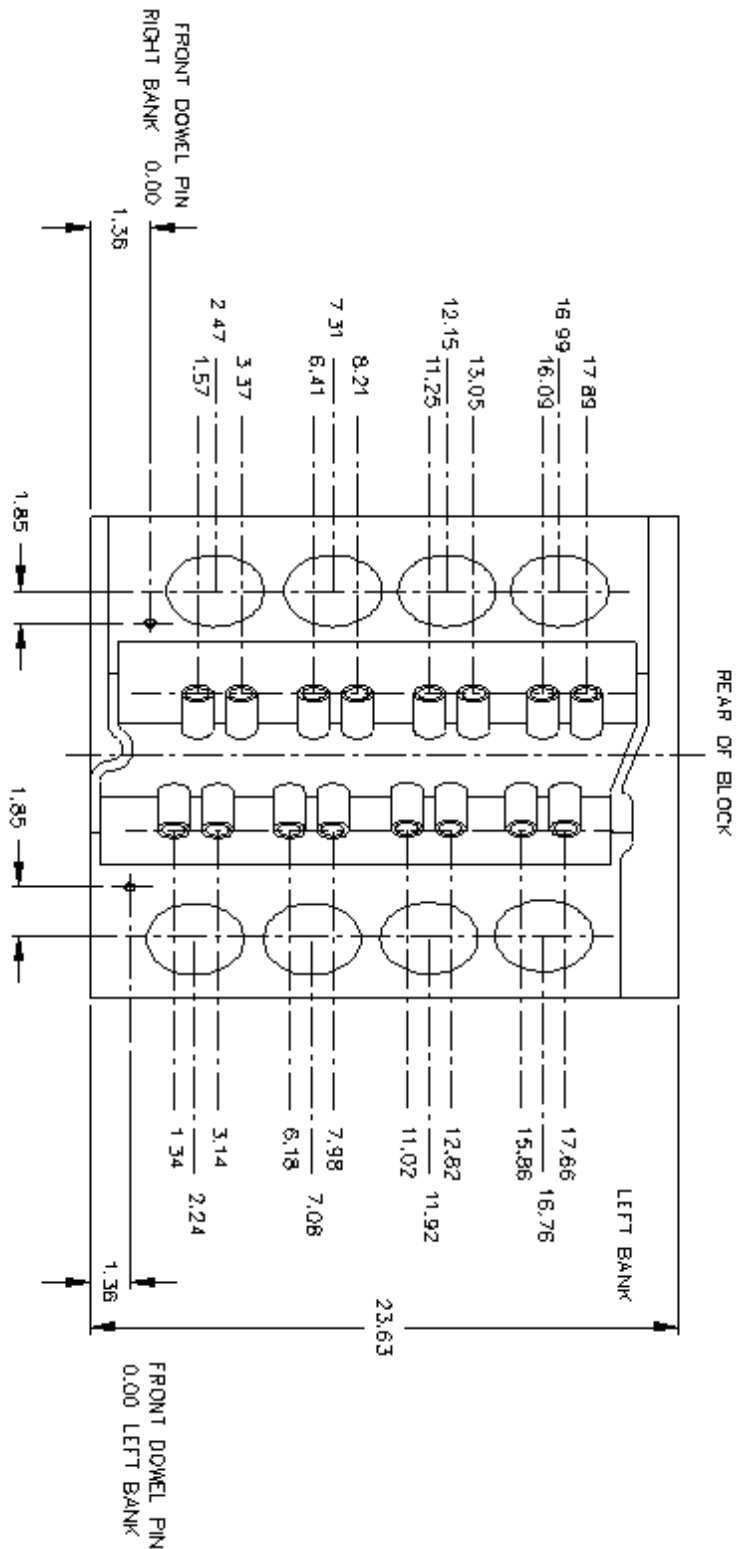

Chevrolet Small Block Dimensions

Block	Cam Bore Center to Crank Bore Center Distance	Lifter Bore Angle	Cam Bore Dia	Crank Bore Dia
Small Block Chev.	4.521	49	#1 2.0190 / 2.0210 #5 2.0090 / 2.0110	

Specifications are accurate to the best of our knowledge and have been obtained from reliable sources. (HP Books "Chevrolet Power" IZBN #1-55788-087-5 available through most book stores) We provide no guarantee on dimensional accuracy. OEM specs change frequently and we are not notified; check with OEM to obtain specifications for a particular year block.

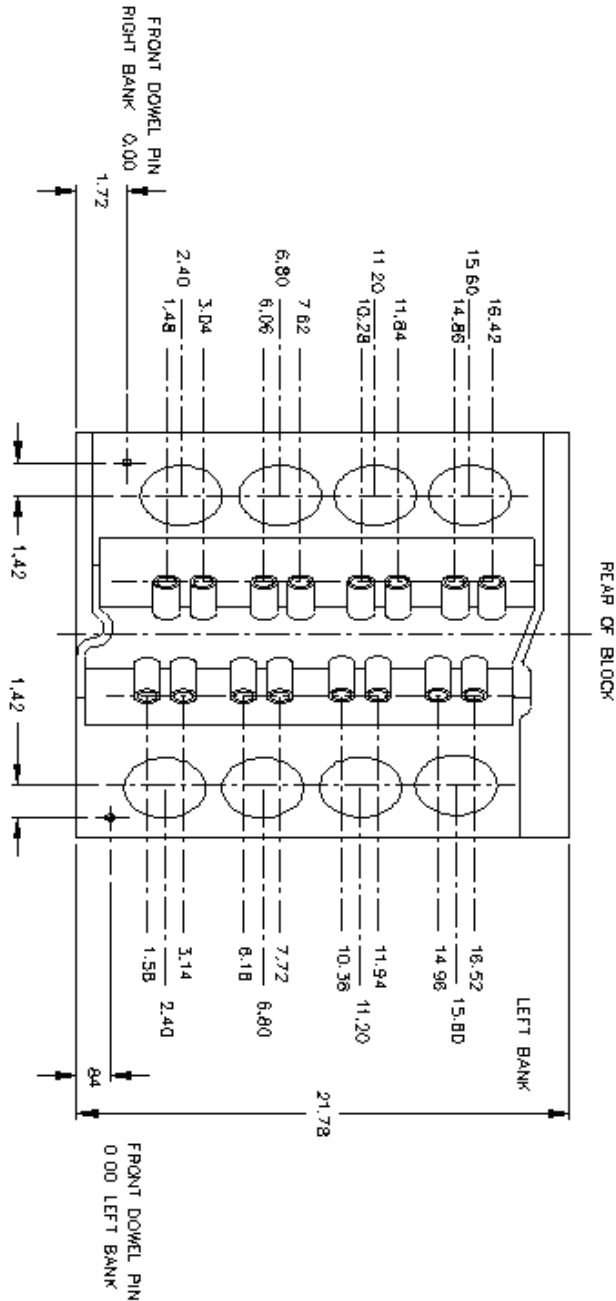

NOTE: REFERENCE DOWEL PIN LOCATION IS DIFFERENT FOR EACH BANK.

Ford 289-302-351W Dimensions

Block	Cam Bore Center to Crank Bore Center Distance	Lifter Bore Angle	Cam Bore Dia	Crank Bore Dia
Ford 289/302/351W Small Blocks	4.804" - 4.807"	41deg 15min / 41deg 45min	2.0925 - 2.0835	2.9417 - 2.9425

Specifications are accurate to the best of our knowledge and have been obtained from reliable sources. We provide no guarantee on dimensional accuracy. OEM specs change frequently and we are not notified, check with OEM to obtain specifications for a particular year of block.

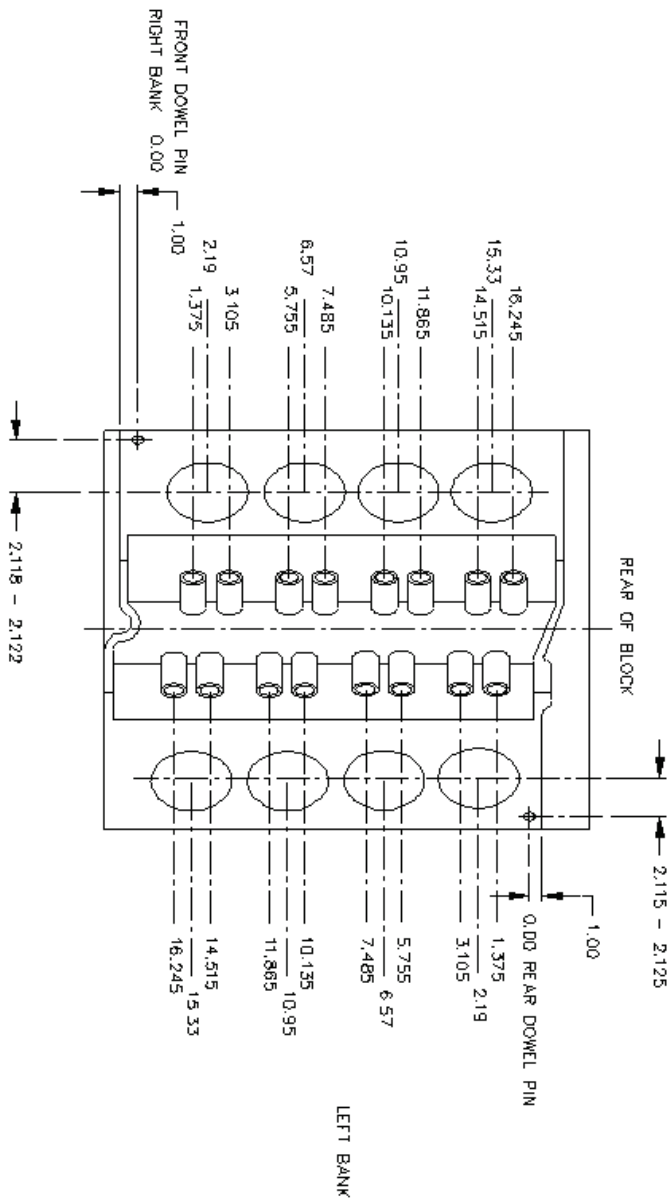

NOTE: REFERENCE DOWEL PIN LOCATION IS DIFFERENT FOR EACH BANK.

Ford 351C-400 Dimensions

Block	Cam Bore Center to Crank Bore Center Distance	Lifter Bore Angle	Cam Bore Dia	Crank Bore Dia
Ford 351C/400 BIG Blocks	5.0435 - 5.0465	41deg 15min / 41deg 45min	#1 2.1258 - 2.1268 #5 2.0225 - 2.0235	2.9417 - 2.9425

Specifications are accurate to the best of our knowledge and have been obtained from reliable sources. We provide no guarantee on dimensional accuracy. OEM specs change frequently and we are not notified, check with OEM to obtain specifications for a particular year of block.

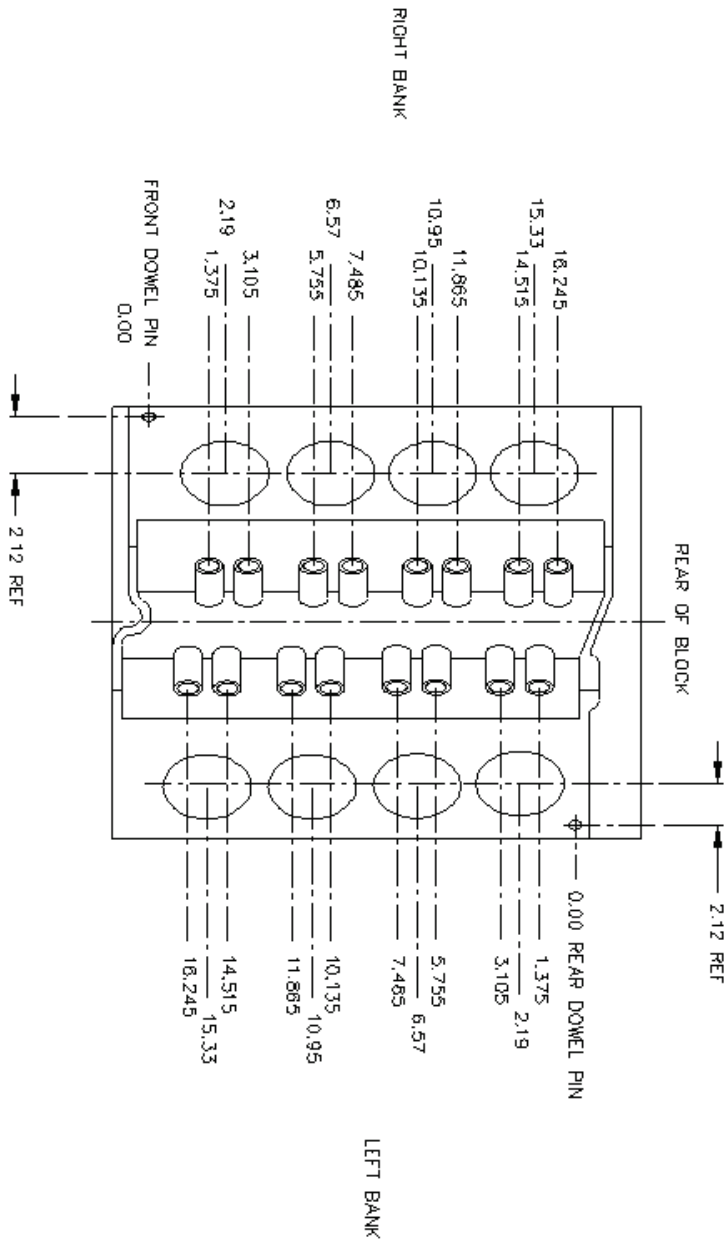

NOTE: REFERENCE DOWEL PIN LOCATION IS DIFFERENT FOR EACH BANK.

Ford 390-427 Dimensions

Block	Cam Bore Center to Crank Bore Center Distance	Lifter Bore Angle	Cam Bore Dia	Crank Bore Dia
Ford 390 / 427 BIG Blocks	5.0475 - 5.0485	41deg 15min / 41deg 45min	#1 2.3095 - 2.3105 #5 2.2495 - 2.2505	2.9417 - 2.9425

Specifications are accurate to the best of our knowledge and have been obtained from reliable sources. We provide no guarantee on dimensional accuracy. OEM specs change frequently and we are not notified; check with OEM to obtain specifications for a particular year of block.

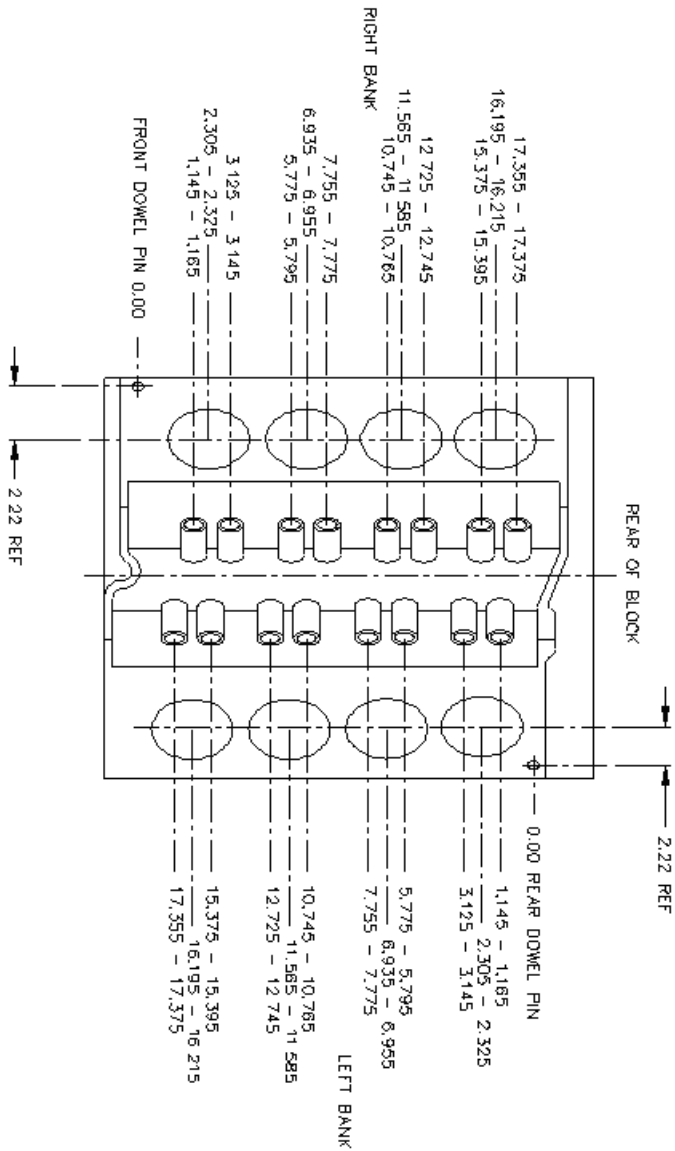

NOTE: REFERENCE DOWEL PIN LOCATION IS DIFFERENT FOR EACH BANK.

General Machine Information

Before starting to build or use any of the Rottler operating programs it is important to understand how the machine operates internally.

The Rottler F69ATC model uses Computerized Numeric Control (CNC). The CNC is always operating when the machine is turned on. However, you will not see the CNC controls unless you switch over to the CNC operating screen.

Homing

The F69ATC **MUST** be homed anytime the software has been started. If the machine has not been homed the reference positions for all programs will be off.

The purpose of Homing the machine is to set reference points in each axis for the machine to operate from. If the machine is not homed the reference points may be off position. The reference point is set in exactly the same position each time the machine is homed. The machine keeps track of these reference positions internally and the operator will not see them. It is important to note that with later model machines the X,Y, and Z have an encoder in them that when the machine is turned on the motors automatically know where they are positioned. In other words, these three motors stay stationary and do not need to move in order to find limit switches and machine home they already know where they are positioned. However, the drum and the spindle are configured such that they will move in order to establish the proper positioning. Also if you have an auto 4th axis fixture or a porting rock and roll fixture these axes will move to find machine home position.

Building Programs

Table of Tools for 3 and 4th Axis Bore Mode

Before building any automatic programs for blocks it is important to understand how the tools are set up in the software. The table of tools within Rottler will be used to define parameters of a tool such as tool name, height offset, and diameter.

Building a Program with Table of Tools

Build the program as described above for 3 and 4 Axis programs using the same vertical zero locations. Put the tools to be used into the Table of Tools.

Assign Tools

Tools to be used in the various operations are set on the Set Zeros page. Simply click on the SET ZEROS tab. To select a Tool, double click on Tool # (Not Set Active. Clicking on Set Active button will engage tool changer to pull up defined tool) on the right side of the screen. This will bring up the Table of Tools window. Highlight the tool you will be using (tools should be defined at this point), and select OK. Do the same to select the Probe you will be using by double clicking on Probe #.



NOTE: The Tool highlighted in red is the currently Active tool.

Below shows the table of tools box that will appear after clicking on either Tool# or Probe#

Program Selected: chev 350 DTG: 0.000 Vert 4.5000 In/Out 0.0000
 Mode Selected: Cylinder Bore Feedrate override 1.00 Horiz 0.0000 4th 0.000

CHANGE TOOL Set Zeros Vertical Stops Left Locations Right Locations

PROGRAM SELECT

LEFT RIGHT IN UP OUT DOWN CW CCW 4th- 4th+

STOP MACHINE

Tool Number	Tool Name	TC Pocket	Tool Diameter	Tool Length	Type of Tool	Des
0	#PROBES#	0	0.0000	0.0000	FlatEndmill	xxxx
1	PROBE1	-1	0.2360	-4.5000	BallEndmill	
2	Probe	1	0.2360	-4.5000	BallEndmill	
3	DRILL	3	1.0000	0.0000	FlatEndmill	
4	5/8-11 TAP	4	0.5000	2.2390	FlatEndmill	
5		5	0.2180	0.0000	FlatEndmill	
6		0	0.3430	0.0000	FlatEndmill	
7		0	1.0000	0.0000	FlatEndmill	
8		0	0.0000	0.0000	FlatEndmill	
9		0	0.0000	0.0000	FlatEndmill	
10	#1/4 TOOLS	0	0.0000	0.0000	FlatEndmill	xxxx
11	short 1/4	0	0.2500	-1.7197	FlatEndmill	ATR
12	1/4 tool	0	0.2500	-0.1341	FlatEndmill	DMG
13	1/4 thin tool	0	0.2500	0.4584	FlatEndmill	test
14	Long 1/4 tool	0	0.2500	0.5313	FlatEndmill	
15		0	0.0000	0.0000	FlatEndmill	
16		0	0.0000	0.0000	FlatEndmill	
17		0	0.0000	0.0000	FlatEndmill	
18		0	0.0000	0.0000	FlatEndmill	
19		0	0.0000	0.0000	FlatEndmill	
20	#3/8 TOOLS	0	0.3750	-2.0000	FlatEndmill	xxxx
21	3/8 5.5	0	0.3750	0.5486	FlatEndmill	PT-t
22	3/8 6.0	0	0.3750	0.5489	FlatEndmill	PT-t
23	3/8 6.5	0	0.3750	1.1281	FlatEndmill	PT-t
24	3/8 7.0	0	0.3750	0.6156	FlatEndmill	PT-t

Move To

01 .0001 MoveTo Tool #: 2

01 .0001 MoveTo Set Active

01 .0001 MoveTo

01 .0001 MoveTo

01 .0001 MoveTo Probe #: 1

01 .0001 MoveTo Set Active

01 .001 MoveTo Set Active

CLAMP MOVE TO ZEROS

AMP CW INDEX CCW INDEX

AMP START SPINDLE

Okay Cancel

The following shows what the screen will look like with two tools assigned and tool #2 is active and machine thinks it is in the spindle. It is highlighted in pink.

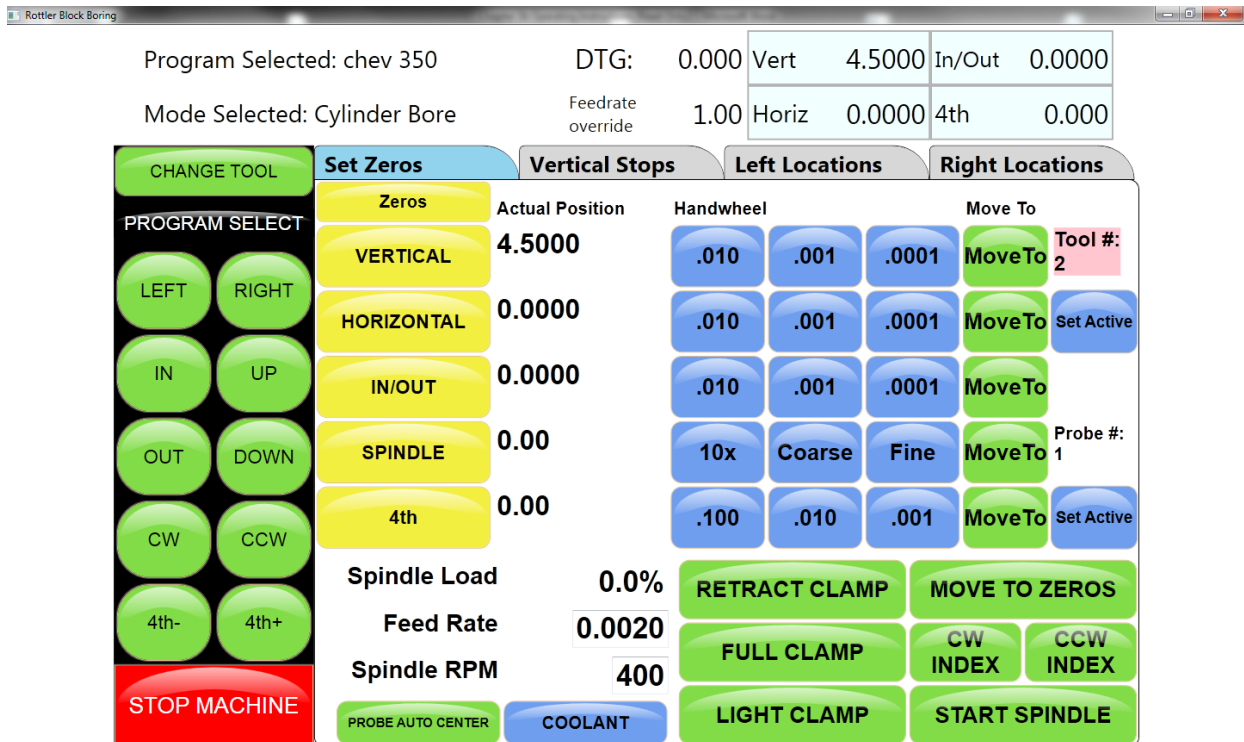

Setting Tools Active

By clicking on the Set Active button above you will engage the tool changer to pull up this tool if it is not already in the spindle (Active). You will know if it is active if the tool # is highlighted in pink.

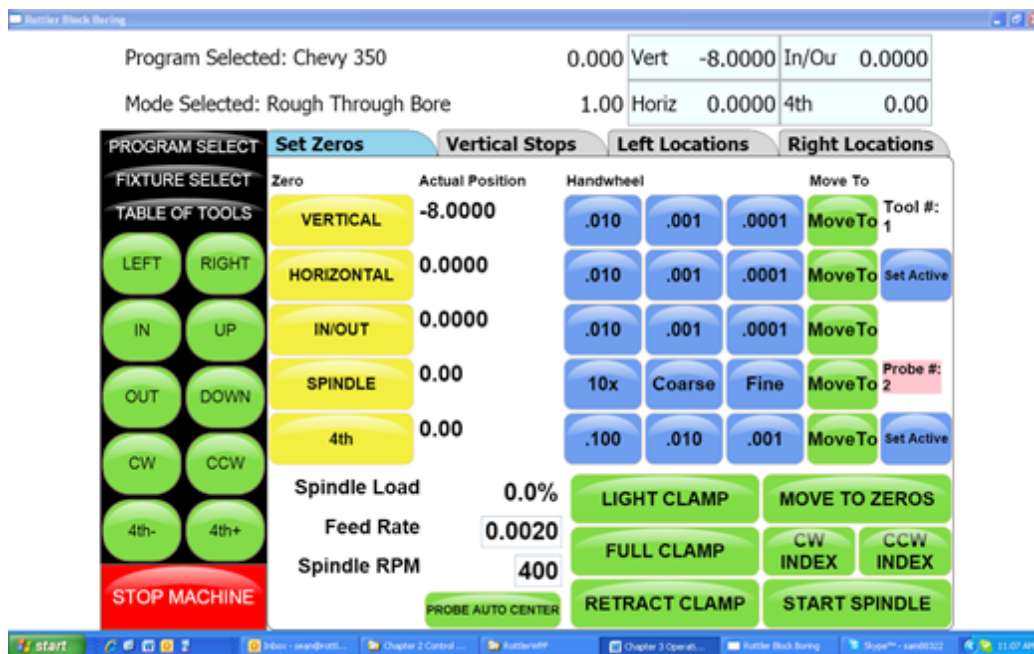

Create a Block Program

Block Programs are listed on the left hand side of the screen. Mode programs that are for a specific Block Model are listed on the right side of the screen.

New

From the Program Select screen select New from the Left hand menu. This will open a window where will enter the Block name and configuration i.e. V6, V8 or Inline and number of cylinders.

NOTE: There is an existing program on start-up of new software called Part Program. This can be deleted after the first Block Program is entered. Or, you can simply highlight Part Program then click on the options button you can then simply change the name.

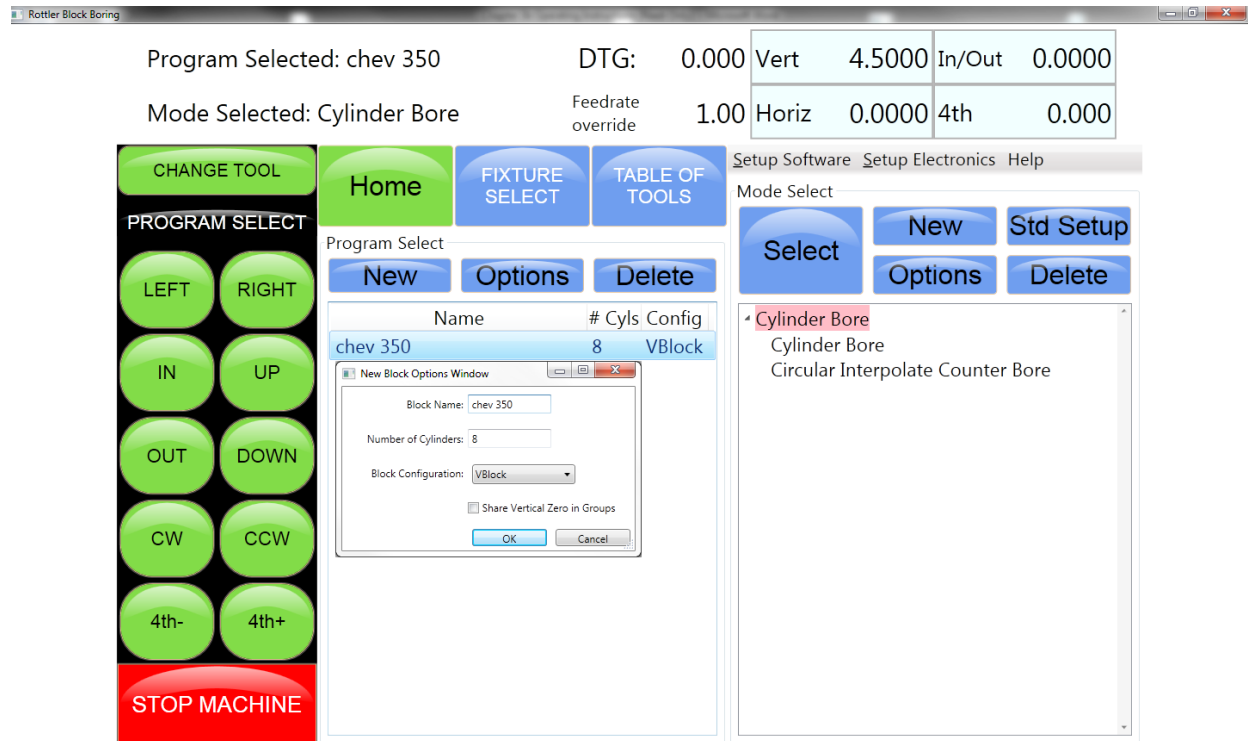

Options

If you need to change the block configuration or name of a block that has already been created, use the Options button. This will bring up the same window as when the block was created.

Creating Operating Modes for a Block Model

Under Program Select on the left side of screen highlight the block you want to start building a program for.

New

Once block is selected, click on New on the right side of the screen. This will bring up a window that lists all the modes that can be performed on the selected block model. Highlight the Mode you want to create and press OK.



The selected mode will show up on the right hand side of the screen.



Std (Standard) Setup

Pressing Std Setup will cause all of the available Modes to be inserted into the Modes area on the right hand side.



Select

Highlight the mode you want to start building a program for then click on the Select button.

Options

Pressing the Options button with a Mode highlighted will open a window where you can change the mode name. There is also a check box to allow positive numbers to be entered into the program where they are negative by default.

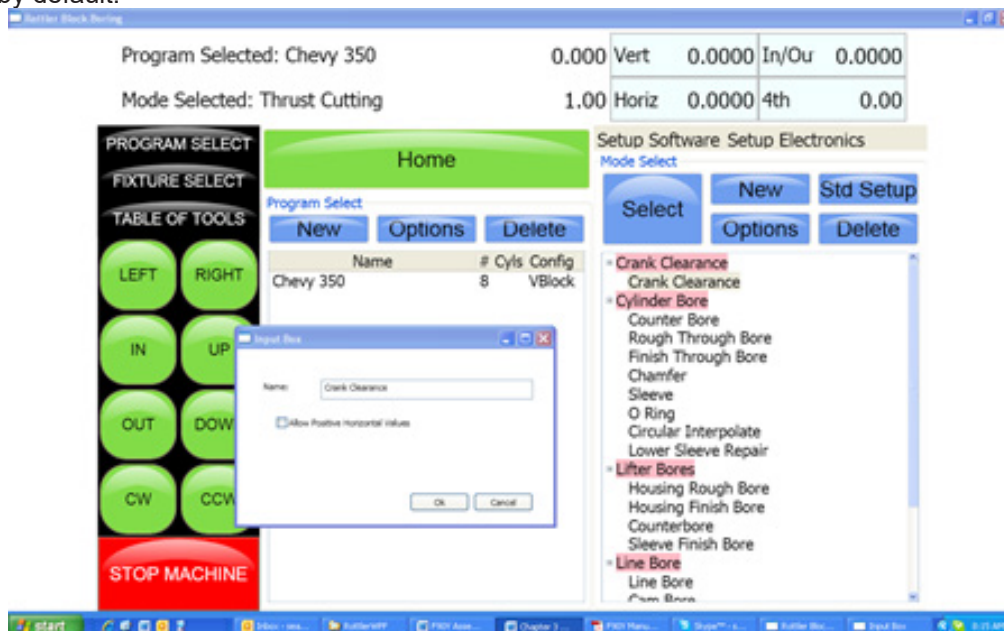

Cylinder Bore Mode 3 and 4 Axis

Select Cylinder Bore found under mode select. This will bring up the boring program with the Set Zeros tab shown below.

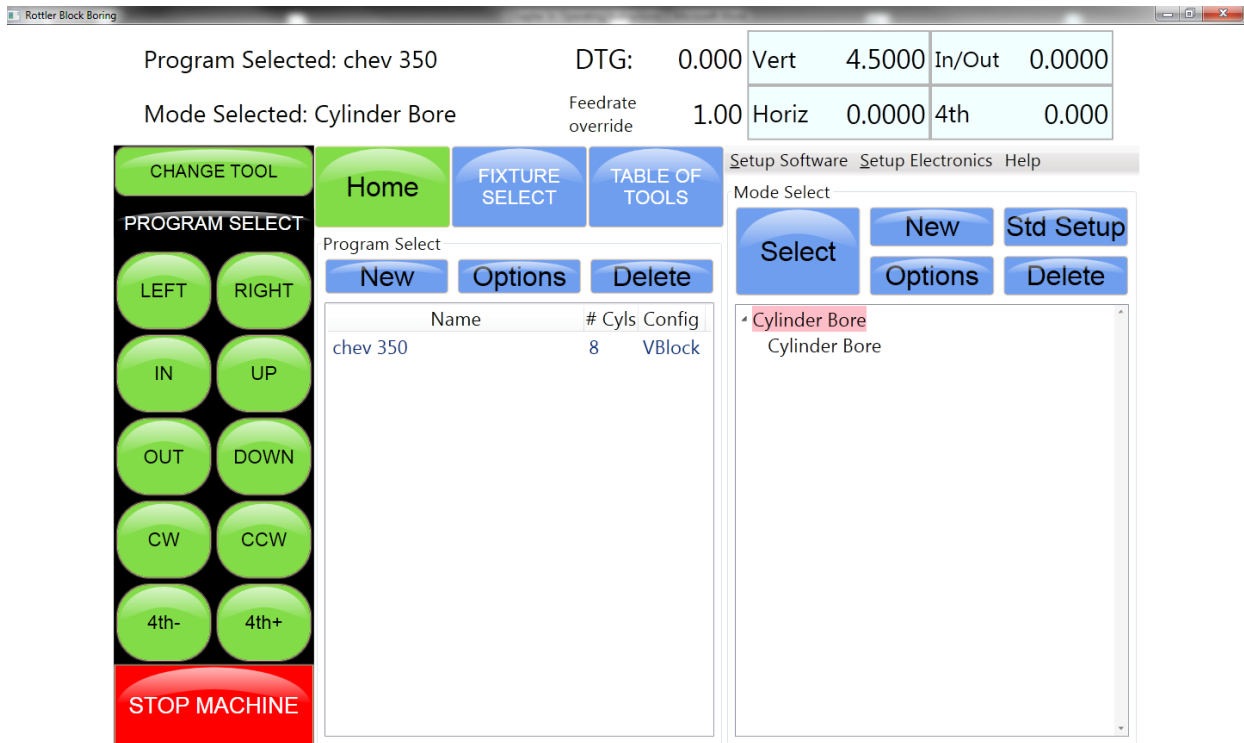

NOTE: Once a certain feature is discussed in a particular mode it will not be discussed again in the following modes.



Setting Zeros

The purpose of setting zero points is to give the operator a specific point to build programs from. The machine also uses these zero points to run the program from. The zero points can be set at any point in the machines' travel. Each axis (except the 4th axis and Vertical. Vertical referencing is done using the table of tools. **(PLEASE READ SECTION IN SECTION 4 DISCUSSING VERTICAL ZEROS)** will need to have a zero point set for the machine to operate from. Every program will save it's individual zero positions. The next time that program is selected the zero position will be the exact same distance from the Home position for each axis.

Horizontal and In/Out Zero

For this example, the Dowel Pin will be our zero point for the Horizontal and In/Out axis. Using an indicator or electronic probe center the spindle on the Dowel Pin then press the Horizontal and In/Out Zero buttons. The display next to these buttons will go to zeros. The Horizontal and In/Out zero positions have now been set.

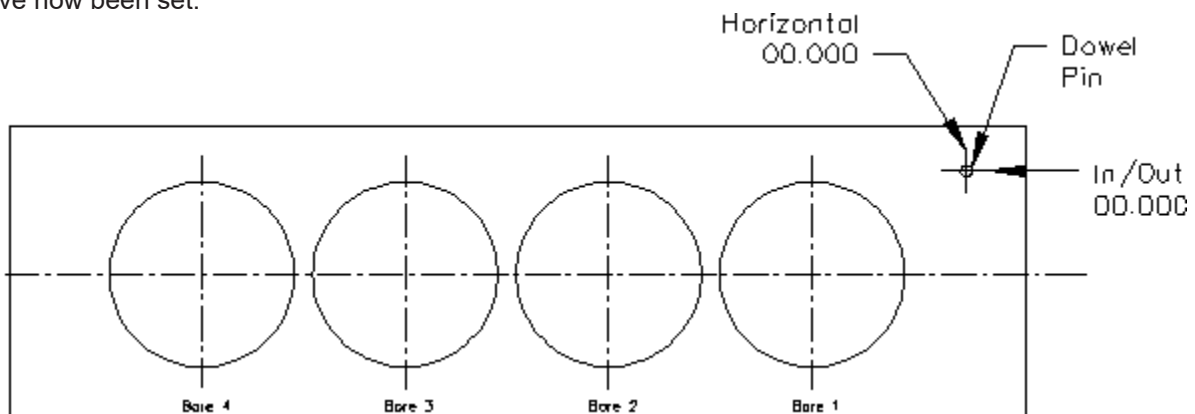

Vertical Zero

There are three different ways to use the boring software, Blueprinting, Indicating and Probing. It is not unusual for all three modes to be used on the same size block. The vertical stops for these different operating programs will vary. Be sure the vertical stops are set correctly for the mode you are using. For this example the mains(or the 4th axis rotation) will be our zero for the Vertical axis.

Spindle Zero

When boring it is necessary to orient the cutter cartridge to the right(X0) then click on the yellow spindle button. At the end of a bore cycle the boring head will move away from the cylinder wall in negative x direction then pull out of the cylinder so you do not score the cylinder wall.

You are finished with the Set Zeros screen, select the next Tab to the Right, Vertical Stops.

Blueprinting

Even if you are not going to be boring a block to the blue print specifications it is recommended to have the Blueprint values entered. It will speed up the process of indicating and probing a block by giving the operator a close estimate of bore location.

Programming Vertical Stops

To build a program you must set the Vertical Stops for the program.

Program Selected: chev 350		DTG: 0.000	Vert 4.5000	In/Out 0.0000
Mode Selected: Cylinder Bore		Feedrate override 1.00	Horiz 0.0000	4th 0.000

CHANGE TOOL	Set Zeros	Vertical Stops	Left Locations	Right Locations	
PROGRAM SELECT LEFT RIGHT IN UP OUT DOWN CW CCW 4th- 4th+ STOP MACHINE	BORE PROFILE		PROBE OPTIONS		
	Block Clearance	12.0000 SET	Probe Clearance	12.0000 SET	
	Centering Height	9.2500 SET	Probing Height	8.8000 SET	
	Start Boring Height	9.1000 SET	Largest Probe Diameter	0.0000	
	<input type="checkbox"/> Horizontal Offset for Honing				
	Bottom of Bore	3.0000 SET			
	<input type="checkbox"/> Washout Cycle				
	<input checked="" type="checkbox"/> Stop and Index Spindle After Cycle				
	HANDWHEEL				
	Vertical	.010 .001 .0001			

Block Clearance

This is the distance above the zero position or block deck allowing the cutterhead to move to the next bore unobstructed. If you are Blueprinting a block the number will be just enough to allow the cutterhead to clear the block deck. Since in this example we are using the main as our vertical zero the block clearance will be a larger number. Given that the approximate deck height for a small block Chevy will be in the neighborhood of 9.00" let's use a Block clearance of 12.0"

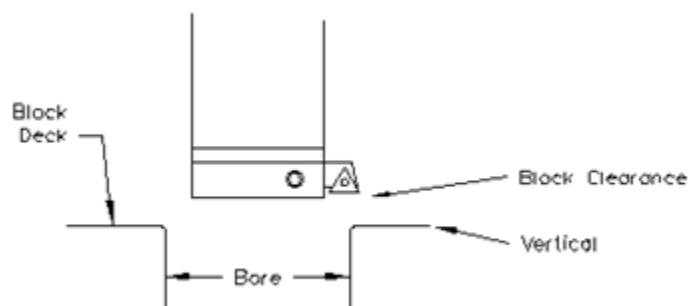

Centering Height

Centering height is the point where the vertical rapids down to get closer to the deck from its block clearance position. In our example the centering height will be 9.25".

Start Boring Height

This is the distance above zero or the block deck where you want the cutterhead to start rotating and the downward feed to start. Generally this is just a short distance above the block deck to minimize the amount of time the machine bores through air. With this example start bore height will be 9.1".

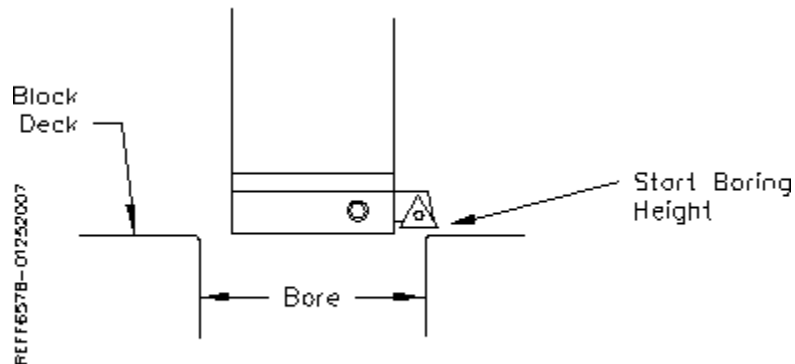
**Bottom of the Bore**

This is the distance below the Block deck where you want the machine to stop boring and retract out of the cylinder. With the above example let us say that the sleeve length is 6.0" that would mean that the bottom of bore distance will be somewhere in the area of 3.0" ($9.0 - 6.0 = 3.0$ "). At the bottom of the bore the boring head should stop so that the cutter cartridge stops at zero degrees then backs away from the wall. When the spindle retracts it will then go to the Block Clearance position.

Note: When Blueprinting the Probe is not used. It will be discussed later in this Section.

Horizontal Offset for Honing

This feature is designed to offset the cutter at a certain height in the lower bore to cut out block web intrusions to make room for the honing process. Checking this box will bring up another value to be entered on the left hand side of the screen.

Program Selected: chev 350		DTG: 0.000	Vert 4.5000	In/Out 0.0000
Mode Selected: Cylinder Bore		Feedrate override 1.00	Horiz 0.0000	4th 0.000

CHANGE TOOL	Set Zeros	Vertical Stops	Left Locations	Right Locations
PROGRAM SELECT LEFT RIGHT IN UP OUT DOWN CW CCW 4th- 4th+ STOP MACHINE	BORE PROFILE		PROBE OPTIONS	
	Block Clearance	12.0000 SET	Probe Clearance	12.0000 SET
	Centering Height	9.2500 SET	Probing Height	8.8000 SET
	Start Boring Height	9.1000 SET	Largest Probe Diameter	0.0000
	<input checked="" type="checkbox"/> Horizontal Offset for Honing		AFTER HORIZONTAL OFFSET	
	Start Offset Height	0.0000 SET	Horizontal Offset	0.0100
	Bottom of Bore	3.0000 SET	<input checked="" type="checkbox"/> Change Speeds At Horizontal Offset	
	<input type="checkbox"/> Washout Cycle		Feed Rate	0.0020
	<input checked="" type="checkbox"/> Stop and Index Spindle After Cycle		Spindle RPM	300
	HANDWHEEL		Left Bank	Right Bank
Vertical	.010 .001 .0001	Right Offset	No Offset	

Start Offset Height

This is the vertical depth at which the cutter will shift to the side to start cutting.

Horizontal Offset

This is the distance the cutter will offset from the bore center.

Change Speeds at Horizontal Offset

Often the clearance cut is much larger than the cut for the rest of the bore. For this you can check this box and enter a different RPM and Feed Rate. If a different speed and feed are not needed do not check this box and the same feed and speed will be used that was used to bore the cylinder.

For each bank (of a V Block) you can select the direction the offset should go.

Washout Cycle

Checking this box will open another window on the right hand side of the screen. Here you can enter the RPM and number of revolutions that will be performed when the cutter reaches the Bottom of Bore position. In Through Boring this is not generally used. This is used when a certain type of finish is required on a counter bore or the bottom of a sleeve cut.

Stop and Index Spindle after Cycle

Checking this box will cause the spindle to be indexed to the three O'clock position after the cylinder has been bored but before it retracts. It will also offset to the left before the tool is retracted. This is the default setting. You would not want this check in an operation such as Lifter Boring.

Bore Locations

To build a program you must set the Horizontal and In/Out Stops for the program. All Horizontal and In/Out stop are based from where their zero positions were set. The following illustration shows how the stop positions were derived. These stops would be used when blueprinting a block.

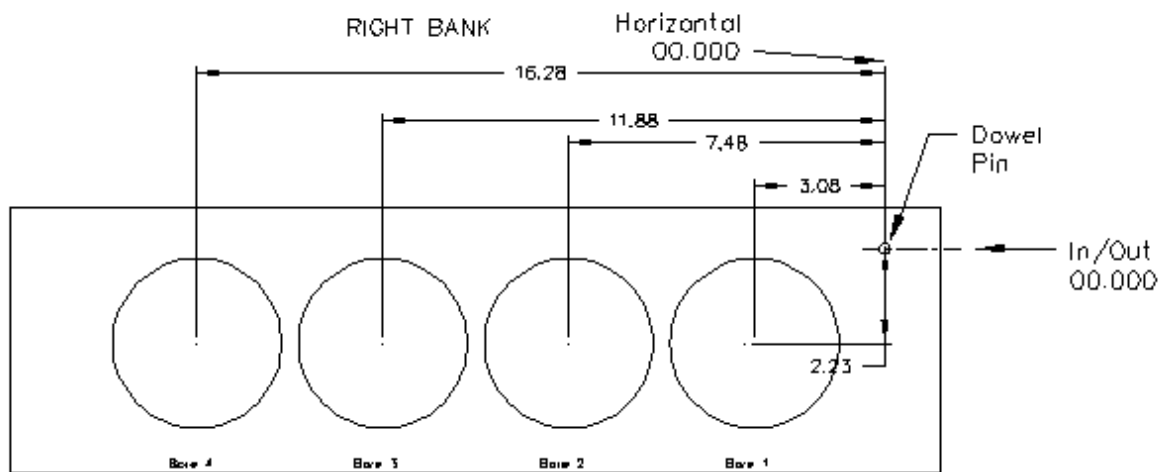
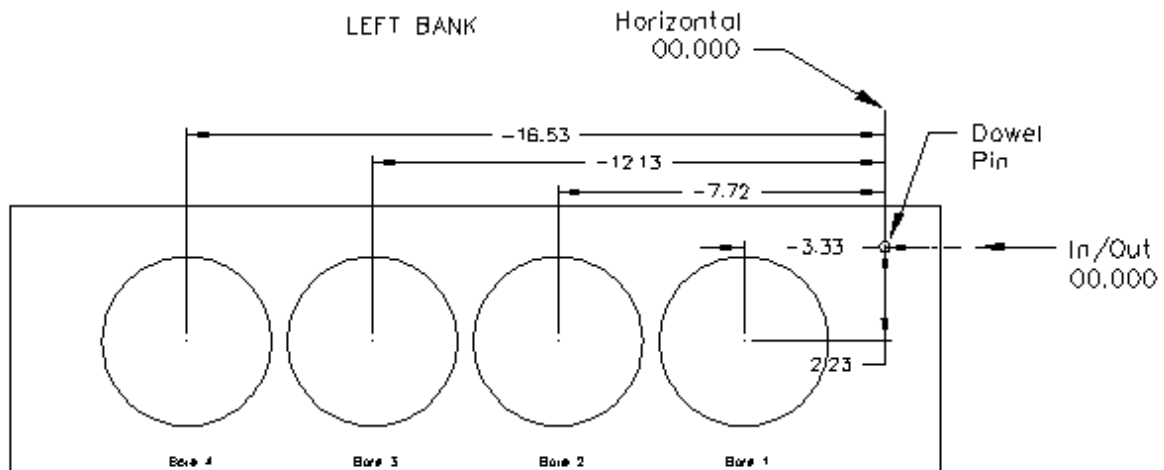

The following is an example of what the screens would look like for the above block.

Left Locations

Program Selected: chev 350 DTG: 0.000 Vert 4.5000 In/Out 0.0000
 Mode Selected: Cylinder Bore Feedrate override 1.00 Horiz 0.0000 4th 0.000

Set Zeros	Vertical Stops	Left Locations	Right Locations
BluePrint	Indicated	Probed	Difference
Copy Values	MOVE 1	MOVE 2	MOVE 3
Horizontal	-3.3300	-7.7200	-12.1300
In/Out	2.2300	2.2300	2.2300
Move In/Out	BORE 1	BORE 2	BORE 3
0.0000			

HANDWHEEL Angle 45.00

Vertical .010 .001 .0001
 Horizontal .010 .001 .0001 4th .010 .001
 In Out .010 .001 .0001 Spindle 10x Coarse

PROBE LEFT START PROBING
 BORE LEFT
 START AUTO CYCLE

Right Locations

Program Selected: chev 350 DTG: 0.000 Vert 4.5000 In/Out 0.0000
 Mode Selected: Cylinder Bore Feedrate override 1.00 Horiz 0.0000 4th 0.000

Set Zeros	Vertical Stops	Left Locations	Right Locations
BluePrint	Indicated	Probed	Difference
Copy Values	MOVE 1	MOVE 2	MOVE 3
Horizontal	-3.0800	-7.4800	-11.8800
In/Out	2.2300	2.2300	2.2300
Move In/Out	BORE 1	BORE 2	BORE 3
0.0000			

HANDWHEEL Angle -45.00

Vertical .010 .001 .0001
 Horizontal .010 .001 .0001 4th .010 .001
 In Out .010 .001 .0001 Spindle 10x Coarse

PROBE RIGHT START PROBING
 BORE RIGHT
 START AUTO CYCLE

The Horizontal and In/Out stops have now been set. If you are using an auto 4th axis you will set your angle in the angle field you see above. If you are not using an auto 4th axis and just using a 3 axes you will not see a field in which you can enter a value.

Boring a Block

Once the Vertical, Horizontal and In/Out stops have all been entered the Spindle RPM and Feed Rate need to be entered. This is done on the Set Zeros screen. Once this is done you can go to the Left and/or Right Bore location screens and bore the cylinders.

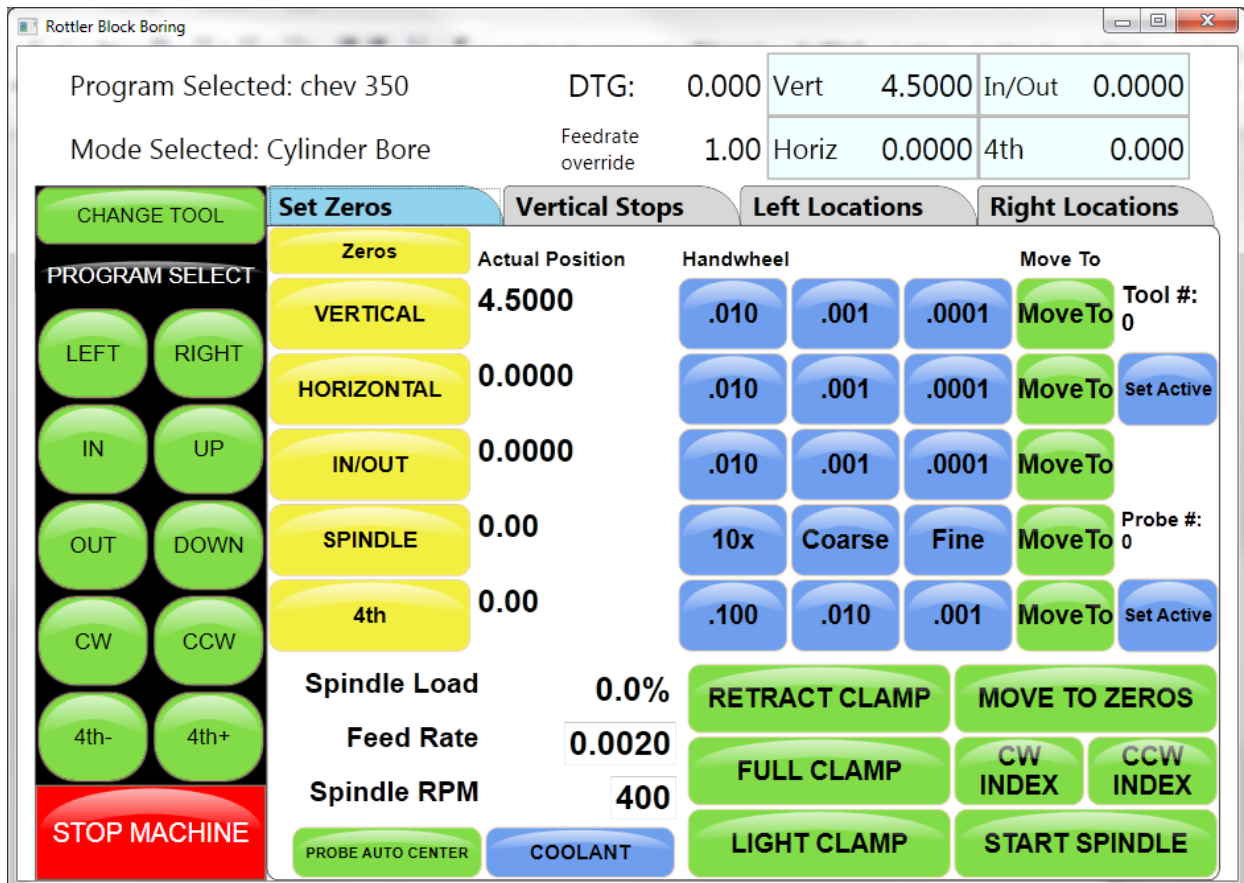

Running the Program

Pressing the Bore Left or Bore Right buttons Will Bore all the cylinders that have Green bore button below them.

Pressing a Bore button once will turn the button Yellow. Any Yellow button will not be bored when the Bore Left or Right button is pressed. In the example below by clicking on the bore left button this would engage the boring routine on the left bank and would exclude bores 2 and 3.

Double clicking any Bore button will turn all the Bore button yellow EXCEPT the one that was double clicked.

Programming Vertical Stops

To build a program you must set the Vertical Stops for the program.

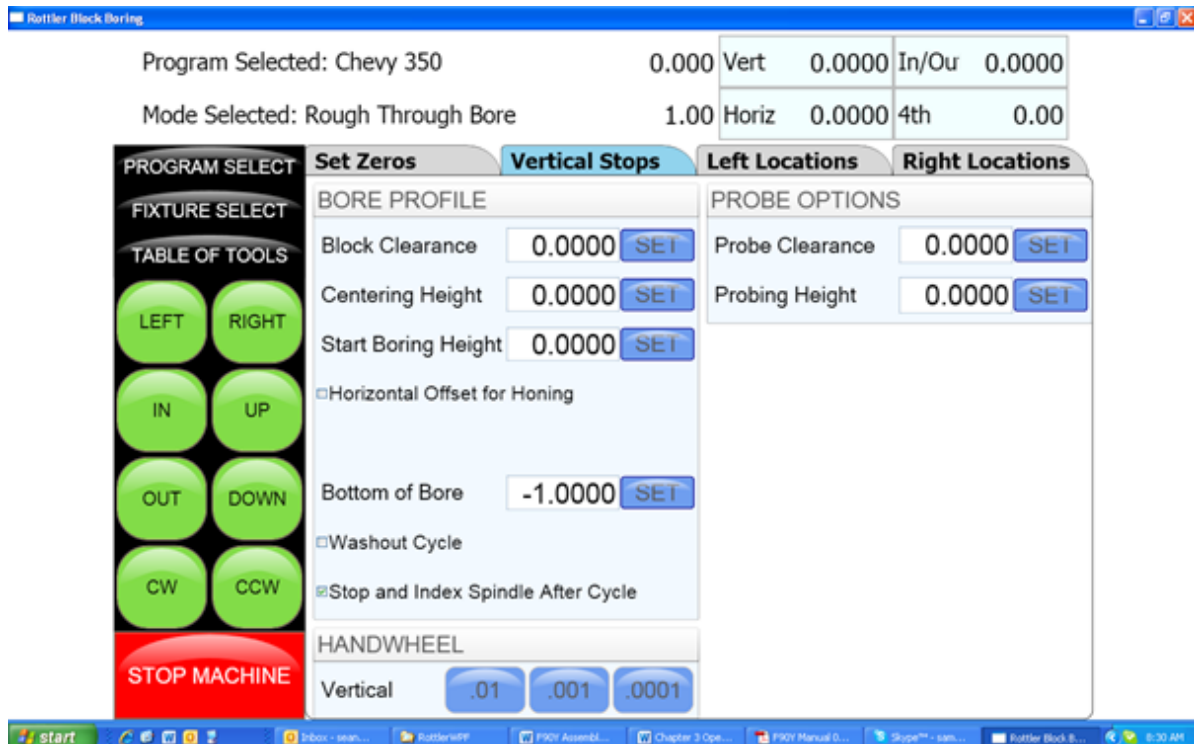

Block Clearance

This is the distance above the zero position or block deck allowing the cutterhead to move to the next bore unobstructed. When you are indicating the cylinders in you must have this stop set so the indicator will clear the block surface when traveling to the next cylinder.

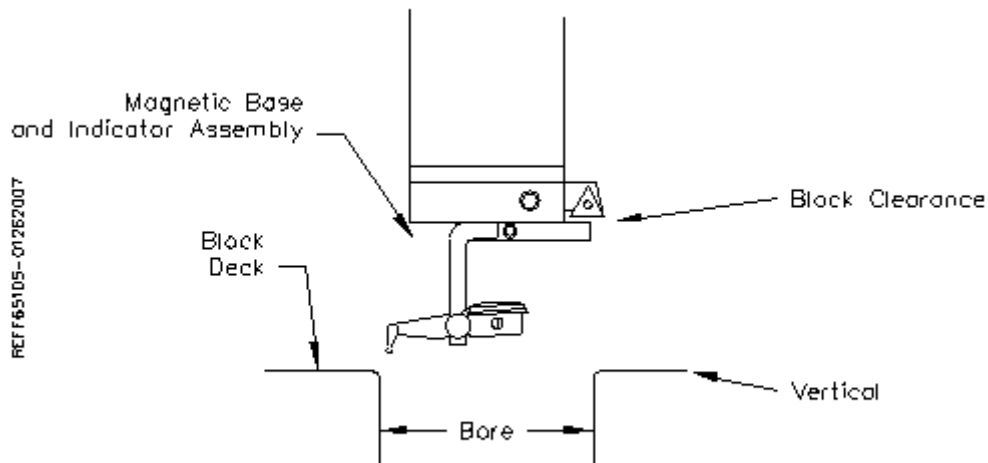

Centering Height

This is a distance above the vertical zero where you will be manually centering the block. The drawing below is a typical set up for manual centering or indicating a cylinder.

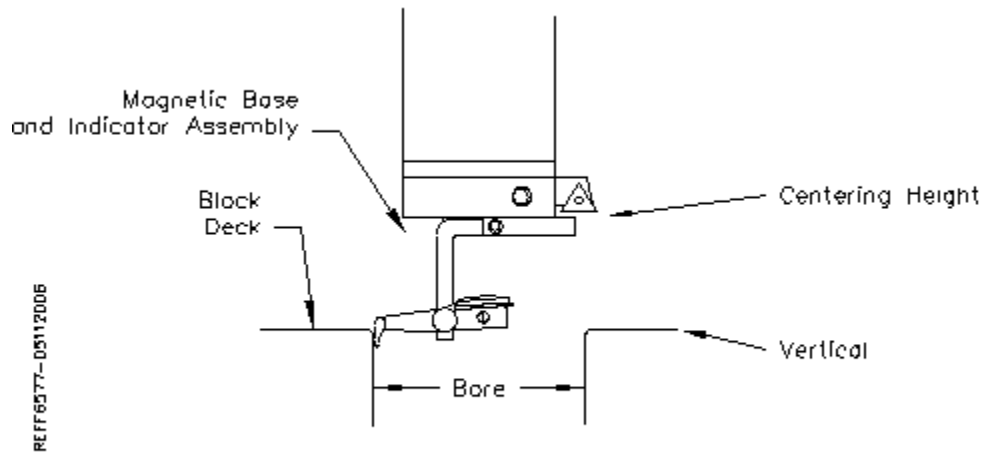
**Start Boring Height**

This is the distance above zero or the block deck where you want the cutterhead to start rotating and the downward feed to start. Generally this is just a short distance above the block deck to minimize the amount of time the machine bores through air. This will be a negative number.

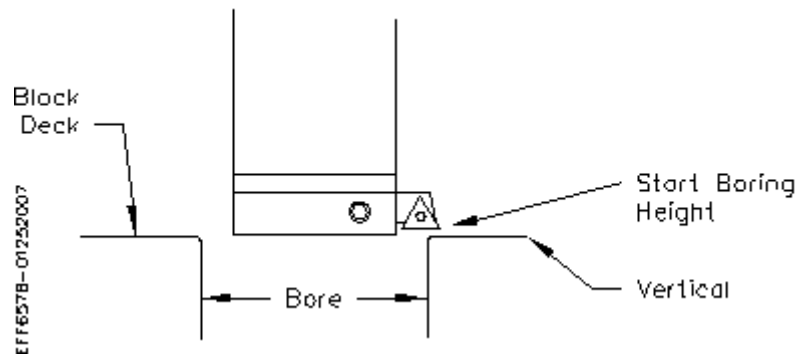

Bottom of the Bore

This is the distance below zero or the Block deck where you want the machine to stop boring and retract out of the cylinder. When the spindle retracts it will then go to the block Clearance position.

This is an example of what the above program would look like on the vertical stops.

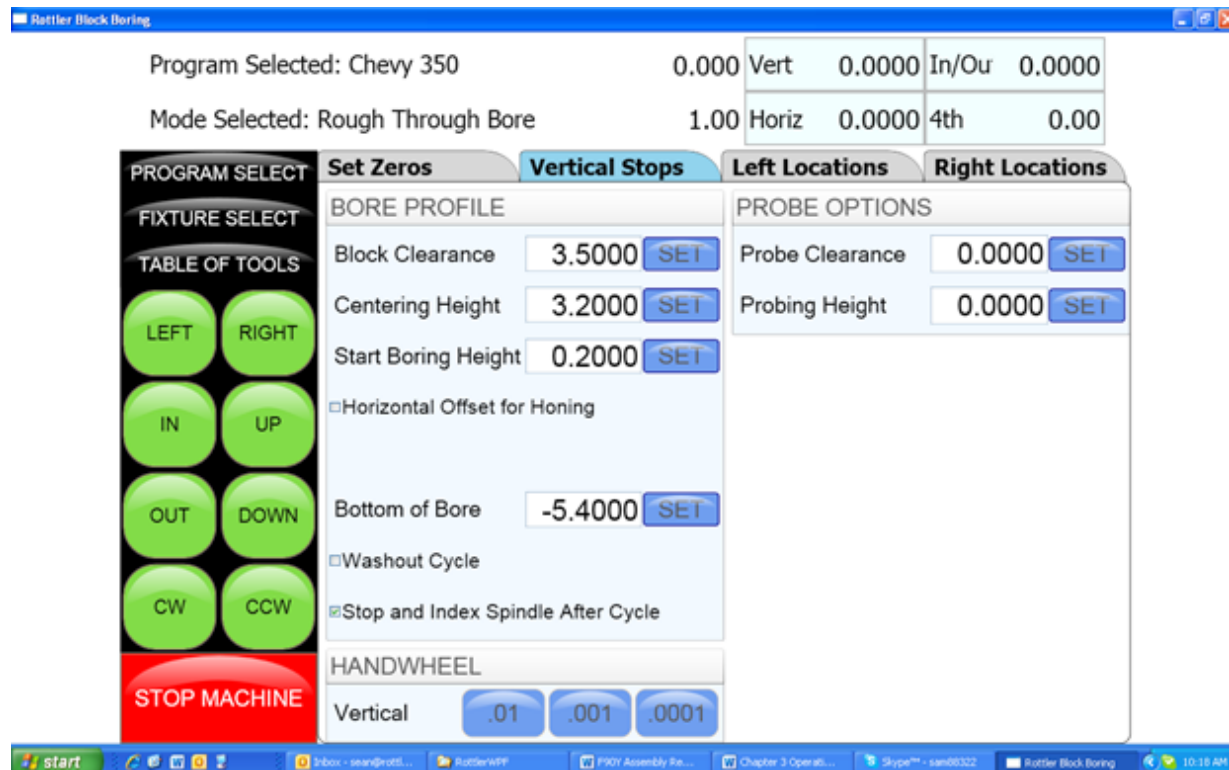

The Vertical stops have now been set. You are finished with the Vertical Stops screen, select Left and/or Right Locations.

Bore Locations

To build a program you must set the Horizontal and In/Out Stops for the program. There are eight (8) Horizontal and In/Out stops used in the boring program. All Horizontal and In/Out stop are based from where their zero positions were set.

Select Left Locations and the Blueprint. Program the blueprint values (or close approximation) into the Horizontal and In/Out stops. Do the same for the Right Locations.

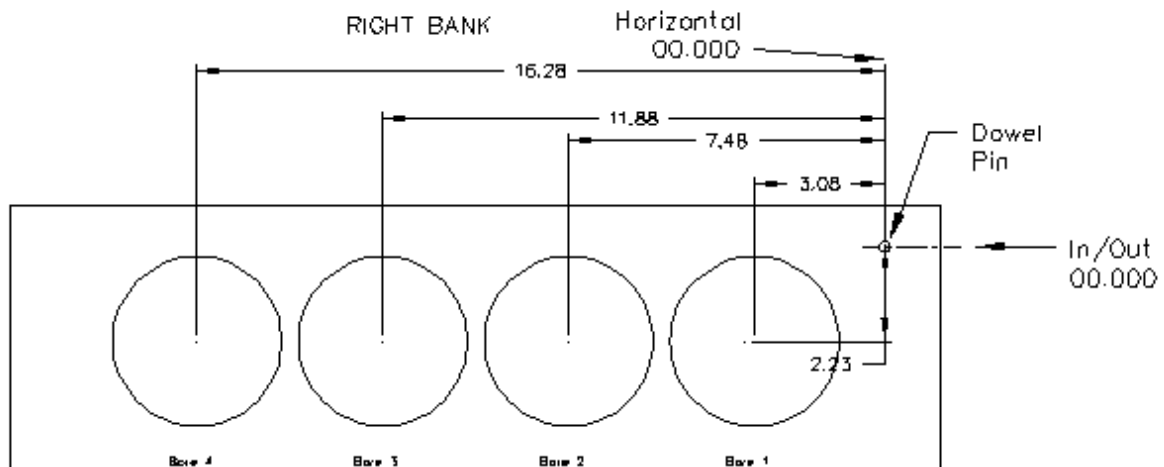
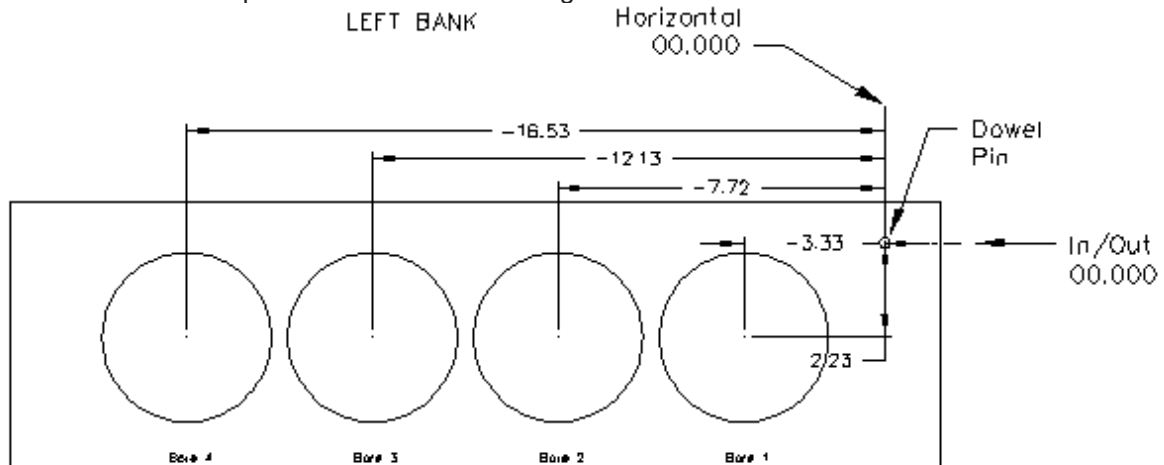

Select Left Locations and then Indicated. If you have programmed the blueprint locations into this program then press Copy Values and then Blueprint. This will cause the values from the Blueprint page to be copied into the Indicated page. This give you a starting point to indicate the individual cylinder from.

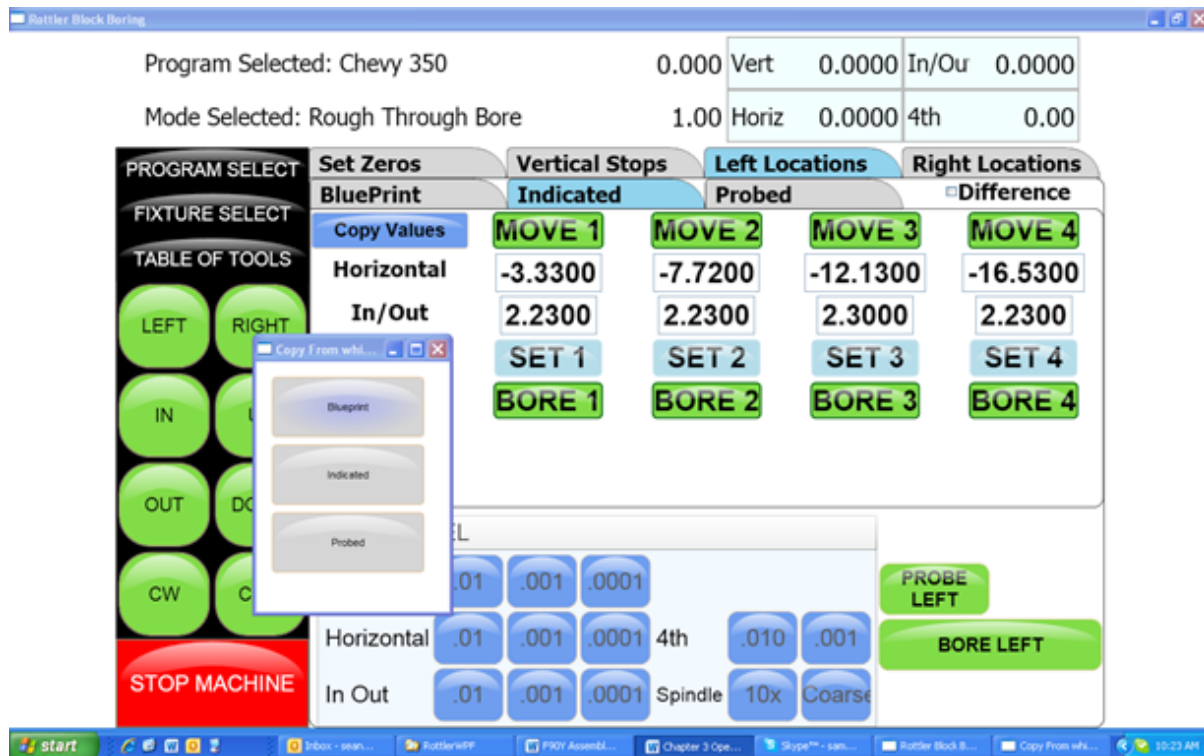

Press the Move 1 button. The machine will move to the first cylinder and stop at the centering position. Manually indicate the cylinder in using the Horizontal and In/Out handwheel. Once the cylinder is centered press the Set 1 button. This will transfer the current position of the machine into the first set of Data Boxes. Repeat this process for all the cylinders that need to be indicated. Press the Right Locations tab and repeat the above procedure for the cylinders to be indicated on the right bank.

Boring a Block

Once the Vertical, Horizontal and In/Out stops have all been entered the Spindle RPM and Feed Rate need to be entered. This is done on the Set Zeros screen. Once this is done you can go to the Left and/or Right Bore location screens and bore the cylinders.

Pressing the Bore Left for Bore Right buttons Will Bore all the cylinders that have Green bore button below them.

Pressing a Bore button once will turn that button Yellow. Any Yellow button will not be bored when the Bore Left or Right button is pressed.

Double clicking any Bore button will turn all the Bore button yellow EXCEPT the one that was double click.

Probing

Even if you are not going to be boring a block to the blue print specifications it is still recommended to have these values entered. It will speed up the process of indicating and probing a block by giving the operator a close estimate of bore location.

Vertical Zero

There are three different ways to use the boring software, Blueprinting, Indicating and Probing. It is not unusual for all three modes to be used on the same size block. The vertical stops for these different operating programs will vary. Be sure the vertical stops are set correctly for the mode you are using. For this example the deck will be our zero for the Vertical axis. Insert a tool holder into the cutterhead you will be using to bore the block. Center the cutterhead over a cylinder. Using the Vertical Handwheel, bring the cutterhead down until the tool just touches the deck and press the Vertical Zero button. The display above this button will go to zero. The Vertical zero has now been set.

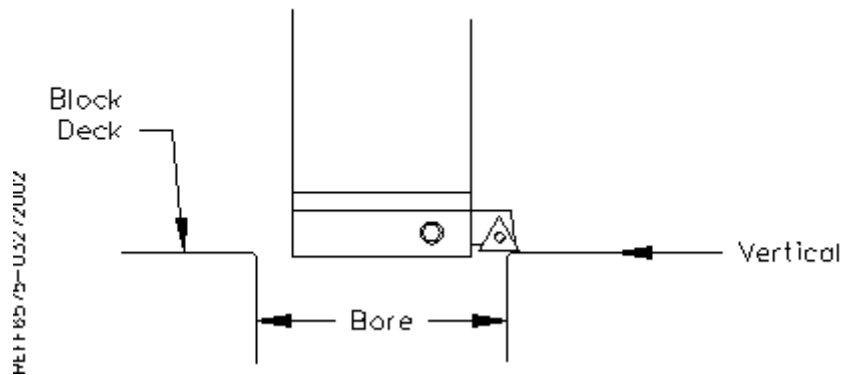

The zeros points for all axis have now been set. All the numbers entered from this point on will reference these zero positions. You are finished with the Set Zeros screen, select the next Tab to the Right.

Programming Vertical Stops

To build a program you must set the Vertical Stops for the program.

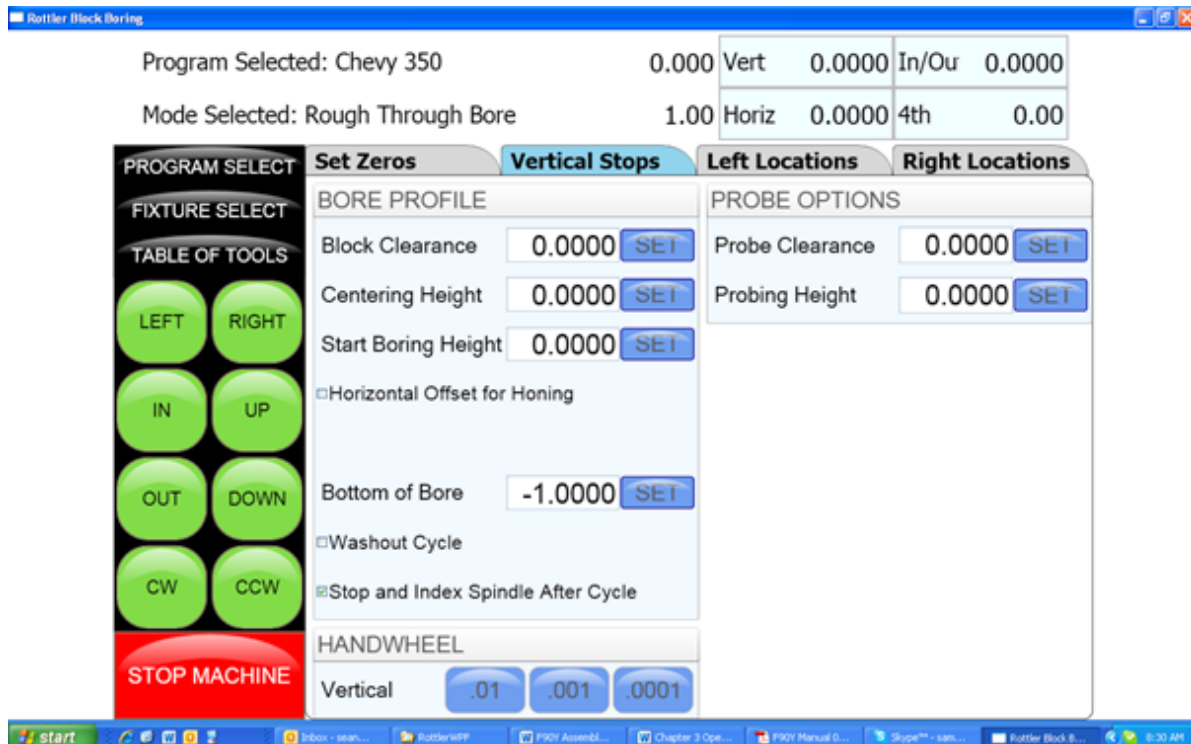

Block Clearance

This is the distance above the block deck allowing the probe to move to the next bore unobstructed.

Centering Height

This stop is not used when you are using the probing feature. It is recommended that it be set to the same value as the Block Clearance.

Start Boring Height

This is the distance above zero or the block deck where you want the cutterhead to start rotating and the downward feed to start. Generally this is just a short distance above the block deck to minimize the amount of time the machine bores through air.

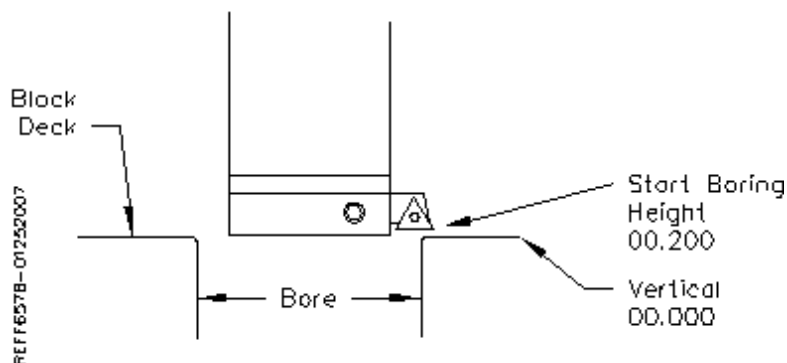

Bottom of the Bore

This is the distance below zero or the Block deck where you want the machine to stop boring and retract out of the cylinder. When the spindle retracts it will then go to the block Clearance position. This is an example of what the above program would look like on the vertical stops.

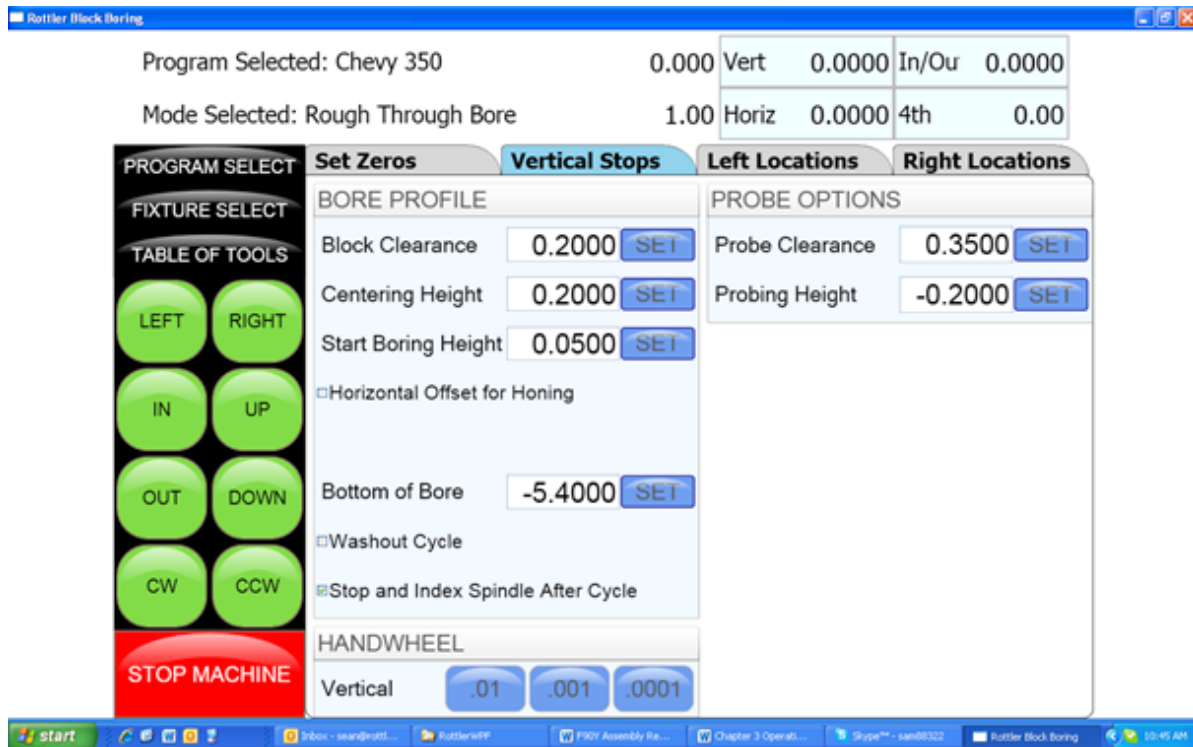

Probe Height

When using the optional Probe... install the probe into the spindle after your vertical positions have been set using the cutterhead.

Using the handwheel and bring the Probe down to the location in the cylinder you will be probing. Press the SET button next to Probe height. This will set the probing height position.

Using the handwheel move the probe up until it can safely move horizontal to the next cylinder. Press the SET button next to Probe Clearance. This will set the clearance height.

The Vertical stops have now been set. You are finished with the Vertical Stops screen, select Left and/or Right Locations.

Bore Locations

To build a program you must set the Horizontal and In/Out Stops for the program All Horizontal and In/Out stop are based from where their zero positions were set.

Select Left Locations and the Blueprint. Program the blueprint values (or close approximation) into the Horizontal and In/Out stops. Do the same for the Right Locations.

Select Left Locations and then Probing. You can probe each cylinder individual by pressing the associated Probe button or you can probe the entire bank by pressing the Probe Left Button. This is the same procedure for the Right Bank.

Probe Auto Center

This feature is located on the Set Zero page. This allows easily find the center of a hole or cylinder.

Roughly place the probe in the center of a cylinder. Press Probe Auto Center. The cylinder will be probed in 4 places, when finished the probe will move to the center of the probed cylinder. Pressing Horizontal and In/Out zero will then establish the center of that hole.

Automatic Probing Procedure

The probe will move to the center of the cylinder to be probed. It will then move to the right at a slow rate until the side of the cylinder is touched, it will then back off slightly and touch the same spot again to confirm position. The probe will then touch off the cylinder in three more spots and retract from cylinder. As each cylinder is probed the Probed Diameter, Horizontal and In/Out positions will be placed into the Data Boxes for the corresponding cylinder.

Press the Right Locations tab and repeat the above procedure for the cylinders to be probed on the right bank.

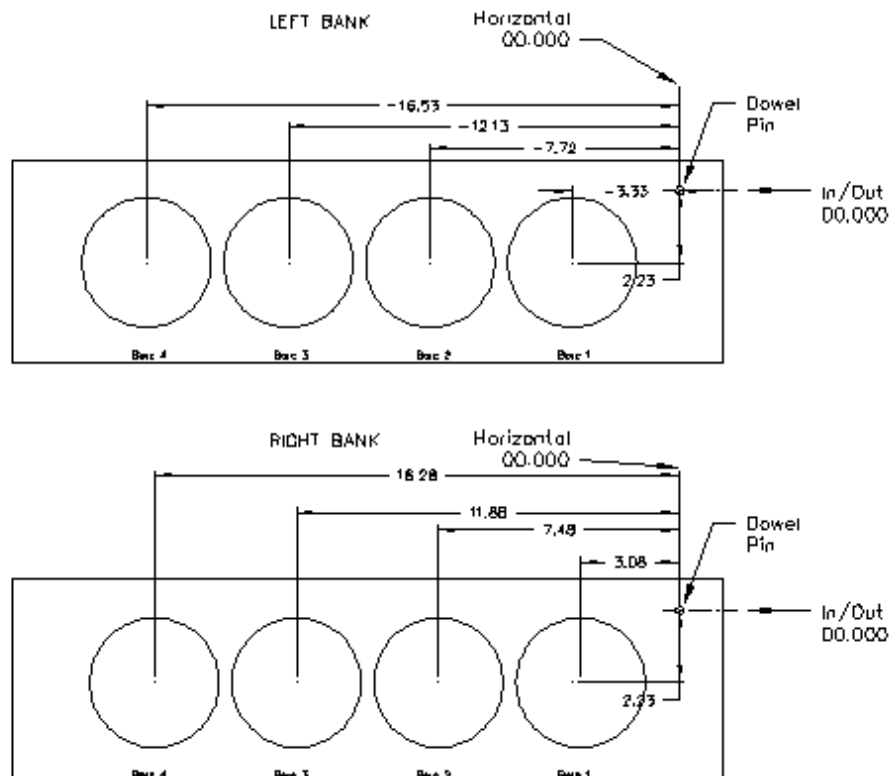

The Horizontal and In/Out stops have now been set.

Boring a Block

Once the Vertical, Horizontal and In/Out stops have all been entered the Spindle RPM and Feed Rate need to be entered. This is done on the Set Zeros screen. Once this is done you can go to the Left and/or Right Bore location screens and bore the cylinders.

Pressing the Bore Left for Bore Right buttons Will Bore all the cylinders that have Green bore button below them.

Pressing a Bore button once will turn that button Yellow. Any Yellow button will not be bored when the Bore Left or Right button is pressed.

Double clicking any Bore button will turn all the Bore button yellow EXCEPT the one that was double click.

Cylinder Bore Mode 4th Axis

NOTE: The program with the 4th axis installed works basically the same as the 3 axis mode. ONLY the differences in operation and screens will be discussed here. Carefully read through the 3 Axis mode and then the 4th axis mode for operation and building programs.

Select Cylinder Bore and then Through Bore on the control panel. This will bring up the boring program with the Set Zeros tab shown.

Setting Zeros

The purpose of setting zero points is to give the operator a specific point to build programs from. The machine also uses these zero points to run the program from. The zero points can be set at any point in the machines' travel. Each axis (except the Spindle rotation) will need to have a zero point set for the machine to operate from.

4th Axis (Rotational) Zero

The Zero position for the 4th (Rotational) Axis should be preset from the factory. If the zero needs to be reset use the following procedure.

There are three (3) flats cut onto the Head Stock Plate. Use the middle flat to set the rotational zero.

Using an indicator off of the spindle indicate the middle flat to Zero all the way along it. Use the 4th Axis hand wheel to do this. When the middle flat is indicated in press the 4th Axis Zero button. You 4th (Rotational) Zero is set.

Finding the In/Out (Y) Axis Zero with 4th Axis

The Head Stock Plate has a hole in it next to the Middle Flat. This hole is centered on the center of the Main and Cam locator shafts.

Building Programs with the 4th Axis

Program are built the same as in the 3 Axis mode with the exception of setting the Angle for each Bank. The Left and the Right Locations page each have an Angle Data Box. Here you enter the angle of each bank from the 4th Axis (Rotational) zero position. The zero position is with the Cam and Crank Locators lined up vertically.

Example: On a Chevy 350 the Left bank would be positive 45 Degrees and the Right Bank would be a negative -45 Degrees.

Setting Vertical Clearance with 4th Axis

It is very important when setting your Vertical and Probe Clearance height that you be sure to account for the Roll Over of the block from bank to bank. When in an automatic program the block will roll from the Left Bank to the Right bank at the Left Bank Bore1 position. It will also rotate from the Bore1 position when going from Right Bank to Left.

Mill Mode 3 Axis

Setting Zeros

The purpose of setting zero points is to give the operator a specific point to build programs from. The machine also uses these zero points to run the program from. The zero points can be set at any point in the machines' travel. Each axis will need to have a zero point set for the machine to operate from.



Horizontal Zero

For this example we are going to set the Horizontal Zero approximately 1/4" from the right hand side of the work piece.

In/Out Zero

For this example we are going to set the In/Out Zero at the center line of the work piece.

Vertical Zero

For this example the Vertical Zero will be at the deck height of the work piece.

Example

Install the Milling cutterhead you will be using into the machine. Move the In/Out axis and center the work piece under the spindle. Press the In/Out Zero button here. Move the Horizontal Axis to that the cutter is overhanging the work piece about 1/4". Bring the Vertical Axis down until the cutter is just above the work piece. At this time it should look similar to the drawing below.

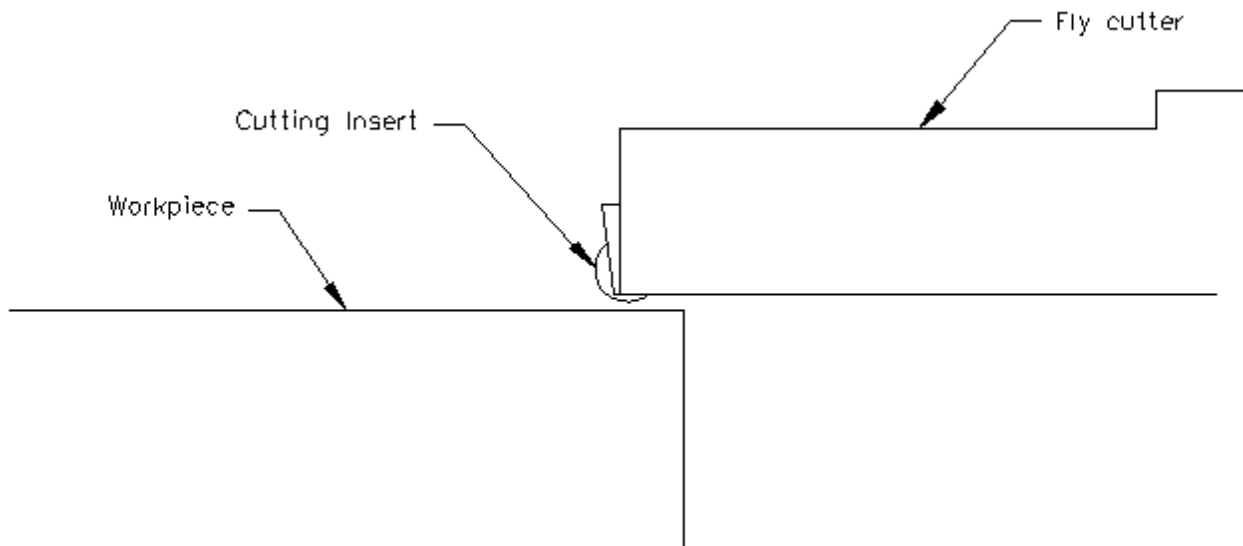

Set the Spindle RPM and Feed rate on this screen.

Start the spindle. Press the Vert .001 button to put the handwheel in .001 per detent. Slowly move the spindle downward until you can hear or see the cutter just touch the block. Press your Vertical Zero button here. Press the Right travel button to feed the spindle off of the work piece. When the cutter has cleared the work piece press the Right travel button again to stop the feeding. Press the Horizontal Zero button here.

Your zero position for all axis have now been set.

Mill Operation

This screen is used to set certain parameters the F69ATC will use to run the automatic cycle.

The screenshot shows the 'Mill Operation' screen with the following data and controls:

Program Selected: chev 350	DTG: 0.000	Vert 4.5000	In/Out 0.0000
Mode Selected: Mill Cycle	Feedrate override 1.00	Horiz 0.0000	4th 0.000

Navigation and Control Buttons:

- CHANGE TOOL
- PROGRAM SELECT
- LEFT, RIGHT, IN, UP, OUT, DOWN, CW, CCW, 4th-, 4th+
- STOP MACHINE
- CUT LEFT, CUT RIGHT, START AUTO CYCLE

Parameter Settings:

Parameter	Value	Action
End		
Horizontal End	-10.0000	SET
Amount per Pass	0.0040	
Vertical Start	0.0000	Copy Highest
Vertical End	-0.0100	Copy Lowest
Additional Depth	0.0000	
4th Axis		
Left Bank Angle	45.00	
Right Bank Angle	-45.00	
Rollover Vertical Clearance	0.0000	
In/Out Offset	0.0000	

Probe and Deck Settings:

Section	Parameter	Value
Rough Settings	Rough Feed Rate	0.0030
	Rough Spindle RPM	600.0000
Overlap Mill Settings	Max Workpiece Width	0.0000
	Cutter Diameter	0.0000
Finish Cut Settings	Finish Amount	0.0020
	Finish Feed Rate	0.0020
	Finish Spindle RPM	400.0000

End

Horizontal End

This displays the current end stop value. To enter a new value press the display and a pop-up numerical key pad will appear. Press the desired end stop value and then ENTER. This is the distance from where the Horizontal Zero was set. You can move the fly cutter manually to the end of the cut and press the SET button. This will automatically put the Horizontal End value in for you.

Amount Per Pass

This is the amount of material removed from the work piece on each pass of the cutterhead.

Vertical Start

This is the Vertical Position the machine will start cutting at. This value is usually Zero which is usually the starting Deck Height.

Vertical End

This is the Vertical Position the machine will stop cutting at. It is the Total amount of material you want to remove in the Milling process.

Copy Lowest Copy Highest

These buttons will be discussed in the Mill Probing section of this Chapter.

Rough Settings

These values are used when taking multiple passes on a work piece. These values can be wet high to remove material quickly. The finish on the work piece does not matter in these settings. There will be a Final pass that will apply the finish to the work piece.

Rough Feed Rate

Enter the desired Roughing Feed Rate;

Rough Spindle RPM

Enter the Desired Roughing Spindle RPM.

Finish Cut Settings

These values will be used for the last pass the machine will make on the work piece. These will determine the finish left on the work piece.

Finish Amount

Enter the amount to be removed on the last pass.

Finish Feed Rate

Enter the desired Finish Feed Rate.

Finish RPM

Enter the desired Finish Spindle RPM.

NOTE: You do not need to have evenly divisible numbers in these sections. The computer will do the math to remove the correct amount each time and for the final pass to be at the amount you set.

The screenshot shows the control interface for a Rottler Block Boring machine. At the top, it displays 'Program Selected: chev 350' and 'Mode Selected: Mill Cycle'. The DTG (Direct Tool Geometry) is set to 0.000, and the Feedrate override is 1.00. A table shows 'Vert' at 4.5000, 'In/Out' at 0.0000, 'Horiz' at 0.0000, and '4th' at 0.000. The interface is divided into several sections: 'Set Zeros', 'Operation', 'Left Deck Probe', and 'Right Deck Probe'. The 'Operation' section is active, showing 'End' settings: Horizontal End (-10.0000), Amount per Pass (0.0040), Vertical Start (0.0000), Vertical End (-0.0100), and Additional Depth (0.0000). The '4th Axis' section shows Left Bank Angle (45.00), Right Bank Angle (-45.00), Rollover Vertical Clearance (0.0000), and In/Out Offset (0.0000). The 'Right Deck Probe' section shows 'Rough Settings' with Rough Feed Rate (0.0030) and Rough Spindle RPM (600.0000), and 'Overlap Mill Settings' with Max Workpiece Width (0.0000) and Cutter Diameter (0.0000). The 'Finish Cut Settings' section shows Finish Amount (0.0020), Finish Feed Rate (0.0020), and Finish Spindle RPM (400.0000). On the left, there is a 'PROGRAM SELECT' panel with buttons for LEFT, RIGHT, IN, UP, OUT, DOWN, CW, CCW, 4th-, and 4th+. At the bottom, there are buttons for 'STOP MACHINE', 'CUT LEFT', 'CUT RIGHT', and 'START AUTO CYCLE'.

Start Auto Cycle

Pressing this button will start the machines automatic cycle. The cycle to be run is determined by the setting on this page. If you only require one pass to be made, do not enter any values into the Rough Setting, only the Finish Cut Settings.

Mill Mode 4th Axis

Setting Zeros

The purpose of setting zero points is to give the operator a specific point to build programs from. The machine also uses these zero points to run the program from. The zero points can be set at any point in the machines' travel. Each axis will need to have a zero point set for the machine to operate from.

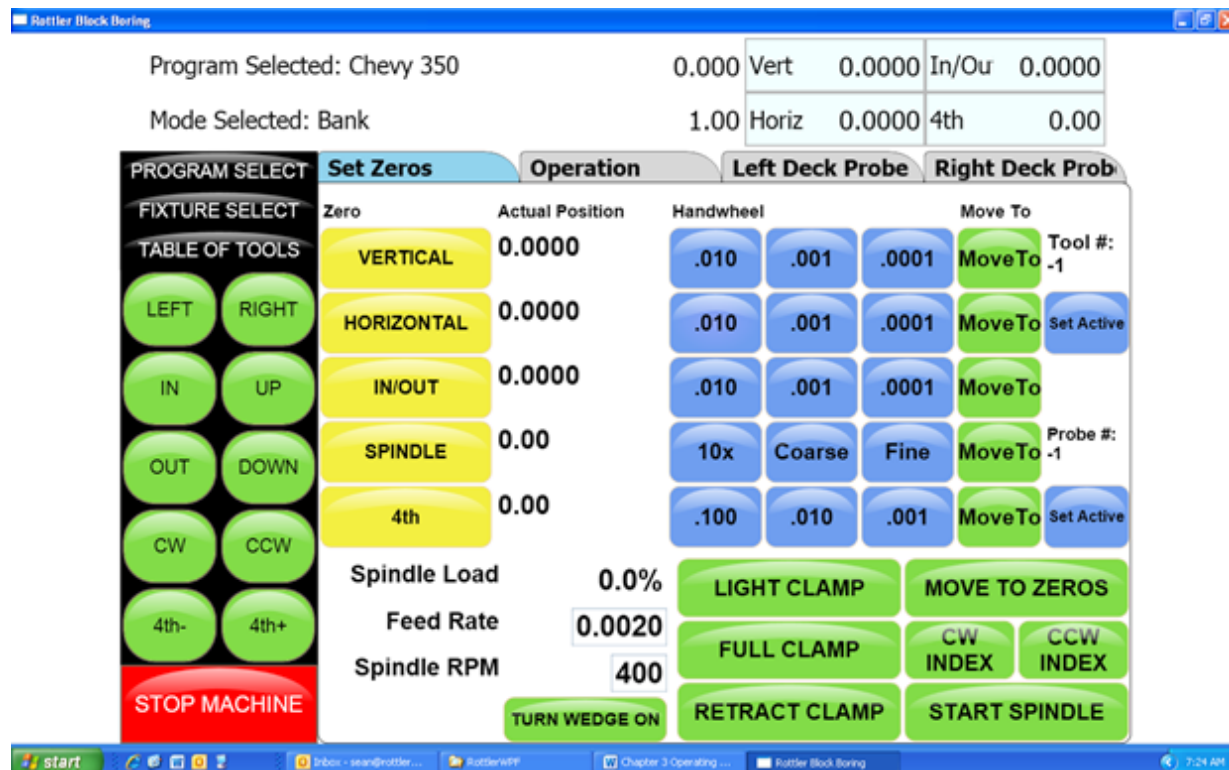

Horizontal Zero

For this example we are going to set the Horizontal Zero approximately 1/2" from the right hand side of the work piece. Assume you have a fly cutter in the spindle and the fly cutter is off to the right of the block so that there is approximately .5 inches from the end of the cutter and the furthest point of the casting of the block(allow enough clearance for rollover from one bank to the other). This will be considered your horizontal zero. So when establishing probing points they will be established from this point of reference in most cases.

In/Out Zero

For this example we are going to set the In/Out Zero at the center line of the work piece.

Vertical Zero

For this example the Vertical Zero will be at the deck height of the work piece.

CAUTION

When setting the vertical zero it is important to check the deck height on both banks of the block before starting a cycle. It is possible that the right bank may be higher than the left bank where the vertical zero was set. This would cause a crash when the block rotated and the cycle was started on the right side.

Example

Install the Milling cutterhead you will be using into the machine. Move the In/Out axis and center the work piece under the spindle. Press the In/Out Zero button here. Move the Horizontal Axis to that the cutter is overhanging the work piece about $\frac{1}{4}$ ". Bring the Vertical Axis down until the cutter is just above the work piece. At this time it should look similar to the drawing below.

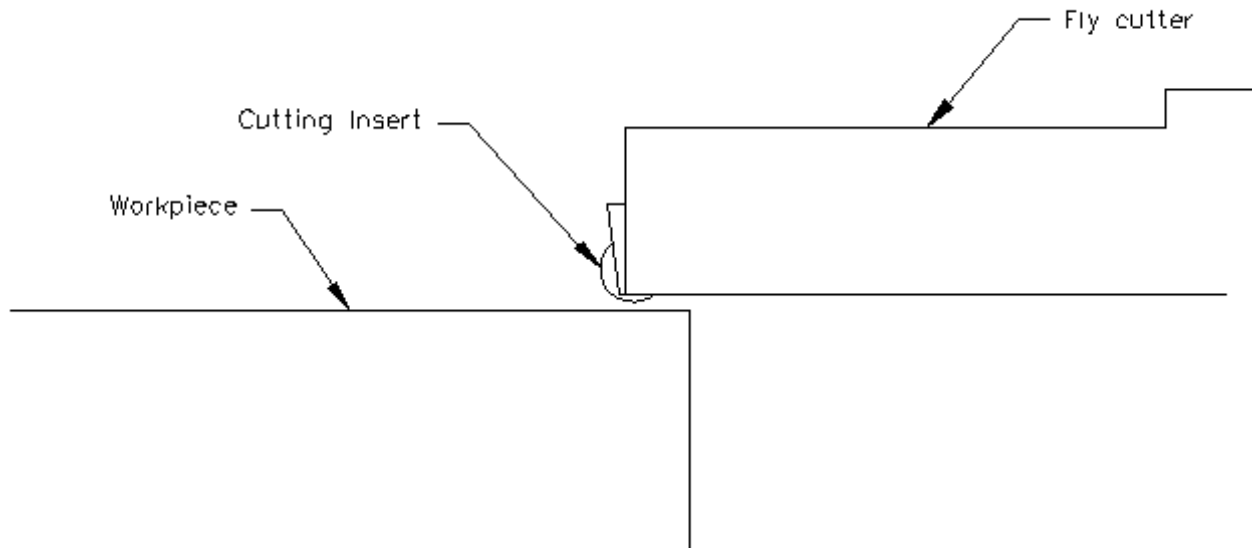

Set the Spindle RPM and Feed rate on this screen.

Start the spindle. Press the Vert .001 button to put the handwheel in .001 per detent. Slowly move the spindle downward until you can hear or see the cutter just touch the block. Press your Vertical Zero button here. Press the Right travel button to feed the spindle off of the work piece. When the cutter has cleared the work piece press the Right travel button again to stop the feeding. Press the Horizontal Zero button here.

Your zero position for all axis have now been set.

Mill Operation

IMPORTANT: Do not move the machine In/Out with the Wedge on. The Wedge comes on automatically when the Mill program is entered. If you need to move the machine In/Out to center on the work Piece use the turn Wedge On/Off button at the bottom of the page to do so. Make sure the Wedge is back on when you start the cycle.

This screen is used to set certain parameters the F69ATC will use to run the automatic cycle.

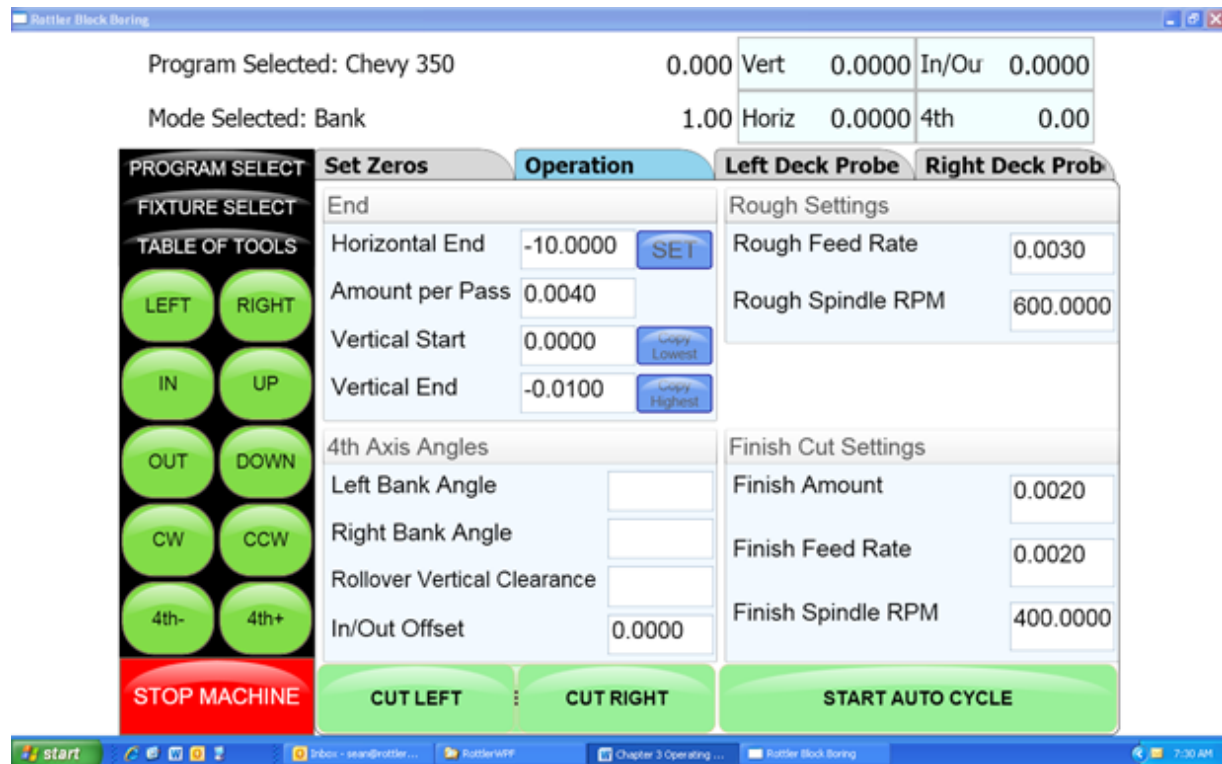

End

Horizontal End

This displays the current end stop value. To enter a new value press the display and a pop-up numerical key pad will appear. Press the desired end stop value and then ENTER. This is the distance from where the Horizontal Zero was set. You can move the fly cutter manually to the end of the cut and press the SET button. This will automatically put the Horizontal End value in for you.

Amount Per Pass

This is the amount of material removed from the work piece on each pass of the cutterhead.

Vertical Start

This is the Vertical Position the machine will start cutting at. This value is usually Zero which is usually the starting Deck Height.

Vertical End

This is the Vertical Position the machine will stop cutting at. It is the Total amount of material you want to remove in the Milling process.

Copy Lowest Copy Highest

These buttons will be discussed in the Mill Probing section of this Chapter.

4th Axis Angles**Left Bank Angle**

Enter the angle of the Left Deck. This is the angle of the block in reference to the Cam and Crank bore being lined up Vertically.

Right Bank Angle

Enter the angle of the Right Deck. This is the angle of the block in reference to the Cam and Crank bore being lined up Vertically.

Rollover Vertical Clearance

Enter the value the Fly Cutter will have to move up vertically to clear the block when it rolls over from bank to bank.

In/Out Offset

This is a value that can be entered to center the fly cutter in the middle of the deck. You In/Out center on the Left bank will not be the center of the In/out on the Right bank. Enter the value the In/Out will need to be moved to center on the Right Bank when it rolls over.

Rough Settings

These values are used when taking multiple passes on a work piece. These values can be set high to remove material quickly. The finish on the work piece does not matter in these settings. There will be a Final pass that will apply the finish to the work piece.

Rough Feed Rate

Enter the desired Roughing Feed Rate;

Rough Spindle RPM

Enter the Desired Roughing Spindle RPM.

Finish Cut Settings

These values will be used for the last pass the machine will make on the work piece. These will determine the finish left on the work piece.

Finish Amount

Enter the amount to be removed on the last pass.

Finish Feed Rate

Enter the desired Finish Feed Rate.

Finish RPM

Enter the desired Finish Spindle RPM.

NOTE: You do not need to have evenly divisible numbers in these sections. The computer will do the math to remove the correct amount each time and for the final pass to be at the amount you set.

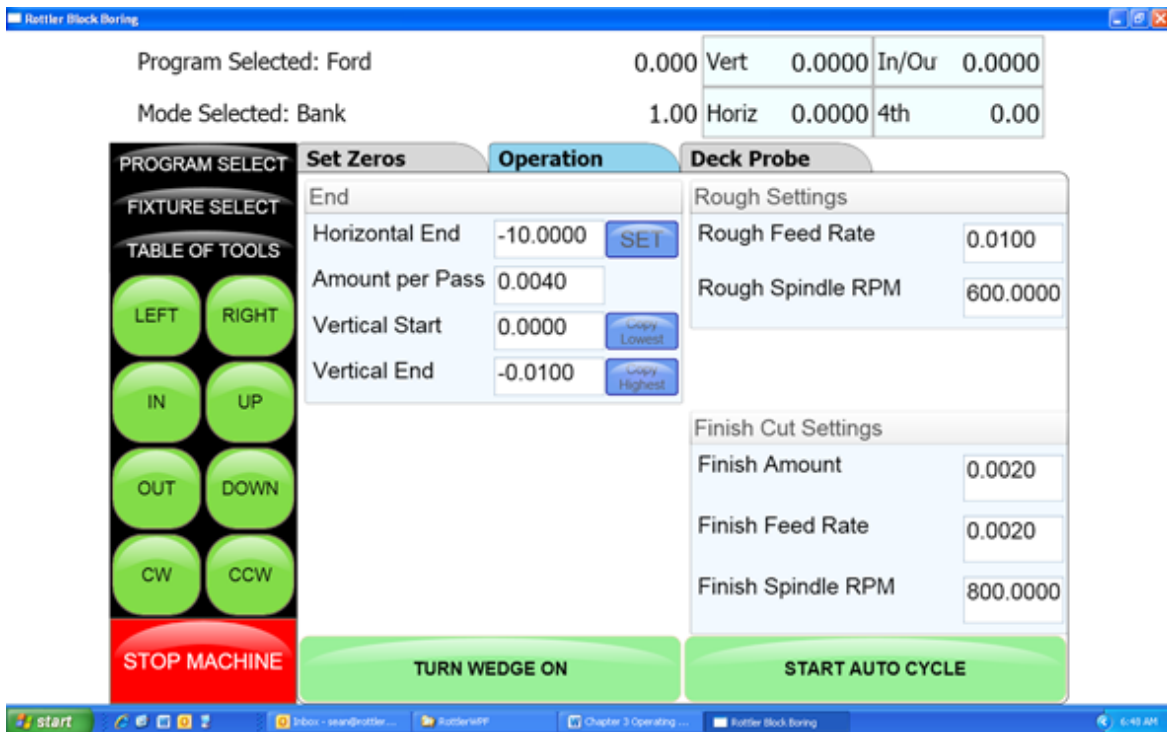

Cut Left and Cut Right

Pressing these buttons will cause the machine to run an automatic cycle (per the parameter defined in the Operations page) on the associated bank.

Start Auto Cycle

Pressing this button will start the machines automatic cycle. The cycle to be run is determined by the setting on this page. If you only require one pass to be made, do not enter any values into the Rough Setting, only the Finish Cut Settings.

Milling Using Automatic Deck Probing

The Rottler Milling program is set up to Automatically Probe the Deck height of a block and then Mill it to a set Deck Height. This can be done on a 3 or 4 axis machine.

Table of Tools for Milling

You MUST use the Table of Tools if you want to Automatically Probe the deck height and cut it to a set height.

Refer to Chapter 2 – Table of Tools to put your Fly Cutter and Probe into the Table of Tools. Once done the Table of Tools Should look similar to the below picture.



The 100mm Probe is Tool 1. The 10" Fly Cutter is Tool 2.

Go to Program Select, then select the block you are working with and then Mill Mode.

Install the Probe physically into the spindle. Rotate the 4th axis to Zero degrees. Indicate the Middle flat on the head stock to be sure it is zero all the way across. There should be a number stamped into the headstock. This is the distance from the Flat to the center of the Crank. Bring the probe down until it just touches the middle flat.

Open the Table of Tools and double click on Tool1 100 mm Probe. Enter the Measured diameter of your Probe. This is not used in the Milling Program but needs to be entered accurately for Probing in the Bore mode.

On the open window select Get Length. This will open another Window. There will be a value, that you cannot edit, in the "Z Location from Zero" this is the distance the Vertical Axis is from home when the Probe touches the Middle flat.

In the Data box for "Z Touch off Height" enter the number that is stamped on the Head Stock. This is the distance from the flat to the center line of the Crank.

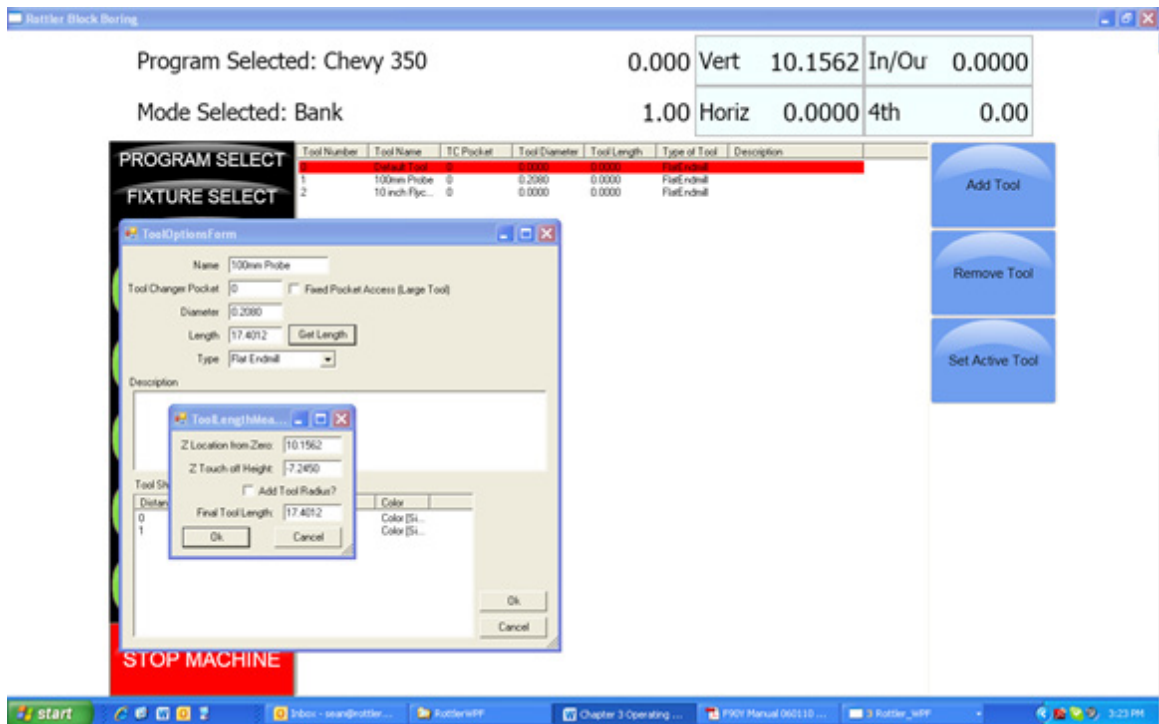

Select OK on both windows. This will put the Total tool length into the Table of Tools. The Vertical Digital Read Out will now consider the center of the Crank bore to be the Vertical Zero position.

When the Probe tip or Cutting insert touches the Deck the Vertical DRO will be reading out the distance from the center of the Crank bore (Actual Deck Height).

Assigning Tools

From the Set Zero Tab, select Probe#. This will open the Tools Select Form. Select Tool 1, 100 mm Probe and click OK.

Select the Tool#. This will open The Tool Select Form. Select Tool 2, 10 inch Fly Cutter and click OK. The tools to be used have now been assigned to the program.

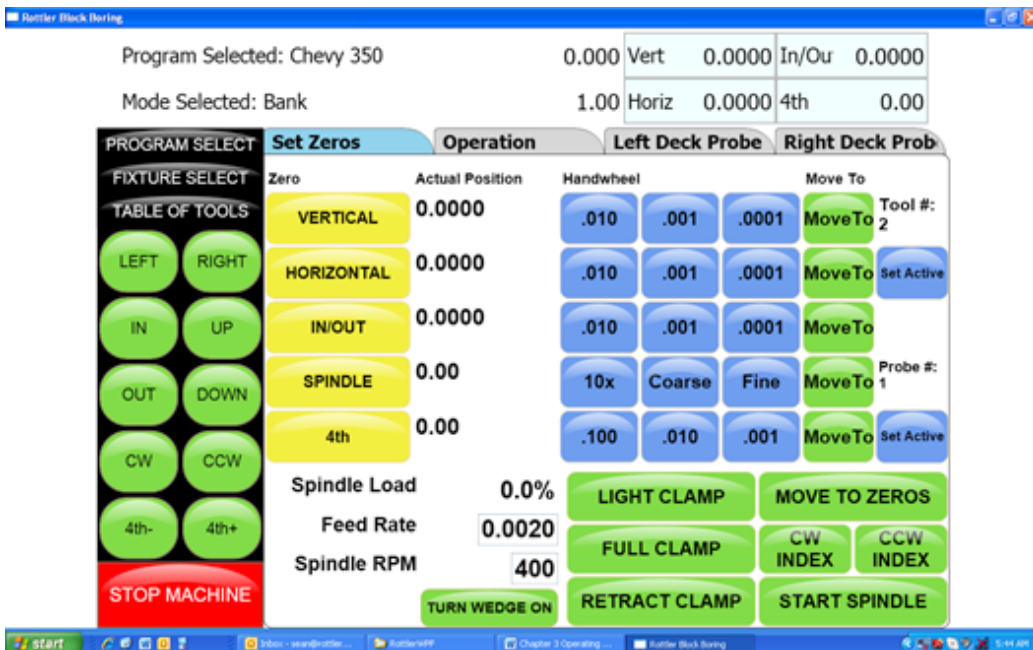
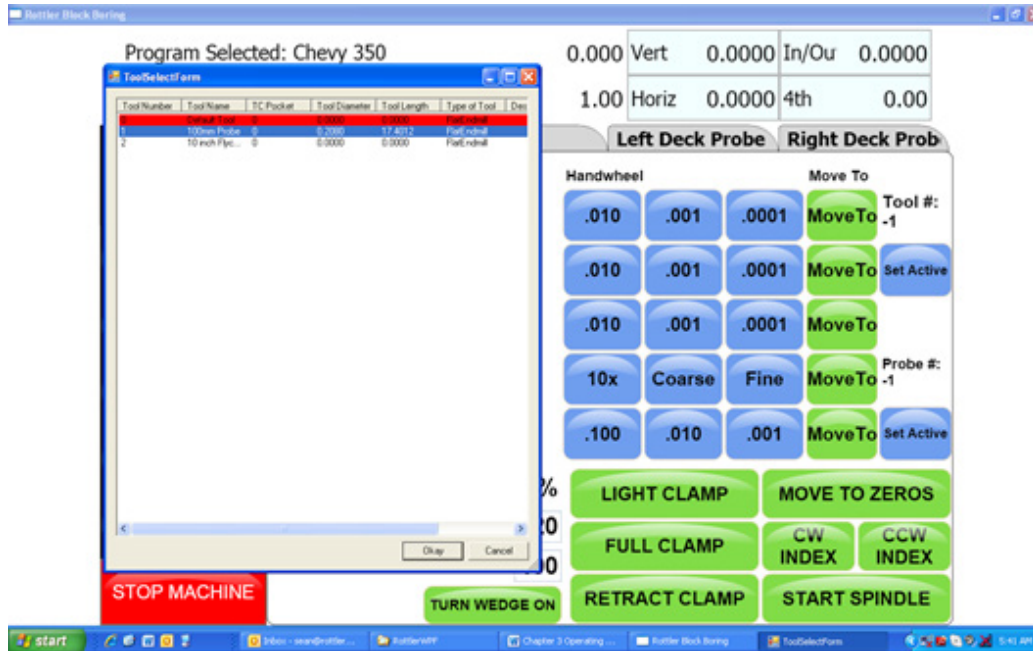

Setting Tools Active

To set a Tool Active (tool to be used) Press the Set Active button below that tool. Set the Probe Active. This will bring up the Tool Change Form. Here you can verify the information for the tool. Select OK. Select OK on the Spindle warning form if it appears.

The Probe# will now be highlighted in Pink, this indicates that the tool is active (being used). If you were to open the Table of Tools at this point, Tool 1 will be highlighted in Red. This also indicates that Tool 1 is active.

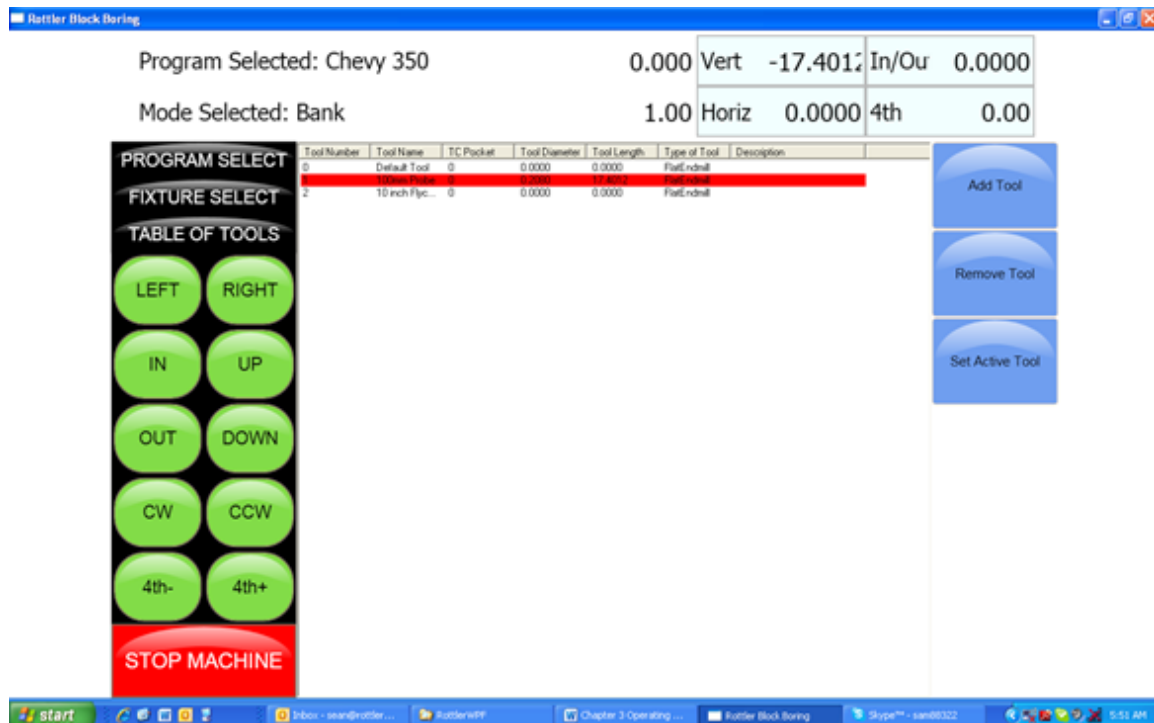

Building a Program Using Table of Tools

Enter all the values that were described in 3 and 4 Axis Milling earlier in the chapter. Physically install the probe into the spindle and set active. Bring the probe down until it just touches the Deck. Look at the value in the Vertical DRO. This is the current deck height at position. Enter that numeric value into the Vertical Start. This gives the Probe a value to start probing the deck at.

Left Deck Probe

Enter the positions you want the Probe to probe here. You can physically move the probe to the locations on the bank you want to probe and hit the set button also.

Right Deck Probe

Roll the block over to the Right Bank. Enter the positions you want the Probe to probe here. You can physically move the probe to the locations on the bank you want to probe and hit the set button also.



Auto Probing

Press the Start Probing button. The machine will first probe each programmed location on the left bank and record the height. The spindle will move to Vertical Clearance height and the block will roll over to the right bank and probe the programmed locations and record them. The block will then roll back over to the Left bank and the spindle will move to the first Left location and stop.

Auto Milling

Go to the Operations Tab.

Vertical Start

Press Copy Highest next to Vertical Start. This will copy the Highest Probed point of either bank. This is the Height at which the Start Auto Cycle would start the first cutting pass.

Vertical End

Press Copy Highest next to Vertical Start. This will copy the Highest Probed point of either bank. This is the height at which the Start Auto Cycle would end the Final Pass. You would use this value if you just wanted to clean the deck up to the lowest point. If you want to cut the Deck Height to a certain value you would manually enter that value into the Vertical End Data Box.

Cut Left or Cut Right

Pressing either of these buttons will Start the Auto Cycle for only the associated bank. That bank will be cut to the set parameters and the machine will stop.

Start Auto Cycle

Pressing this button will start the Auto Cycle for Both Banks. First the Left bank will be cut to the set parameters. The spindle will go to the Clearance Height and Roll over to the Right bank and cut it to the set parameters. The Spindle will again go to the Clearance Height and roll over to the Left bank. The machine will go idle at this point.

Lifter Bore Mode 3 Axis

Lifter Bore programs are built the same as described in the Bore Mode 3 Axis. Only the differences will be discussed in this section.

In / Out Zero

The In/Out zero position for Lifters is the center line of the Cam Bore. An easy way to find the center of the cam line is to use the electronic probe. The following is an example of this procedure. Install the probe into the holder and the holder into the spindle. Bring the probe down until it is in the approximate center of the cam Bar Vertically. Press the Vertical Zero button now (this is only a temporary Vertical Zero position). Using the In/Out handwheel bring the probe up to the Cam Bar until it lights. Press the In/Out zero button here. Move the spindle up enough to clear the Cam Bar, move the probe to the other side of the Cam Bar. Bring the vertical down to the zero position. Hand wheel the probe into the Cam Bar until the light comes on. Note the In/Out position reading. Divide this reading by two. Bring the spindle up until it can clear the Cam Bar. Use the In/Out handwheel and move the In/Out position until it matches the divided number. This is the center line of the Cam Bar. Press the IN/Out Zero button now. The In/Out zero position has been set. The following illustration visual shows the above description.

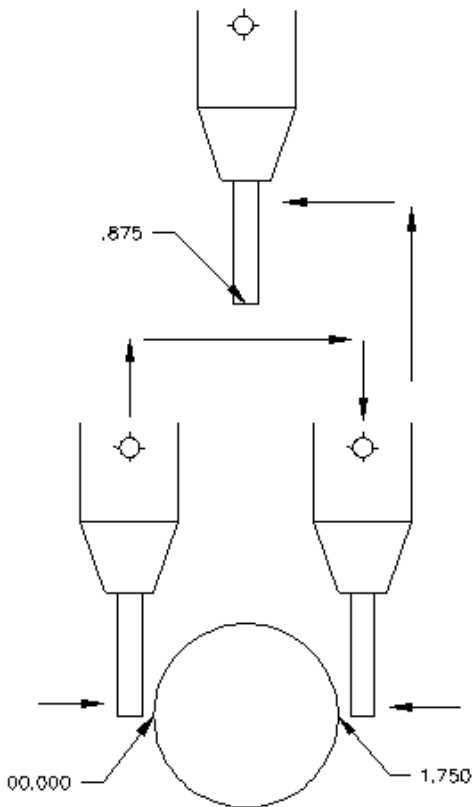

Start Boring Height

Pay particular attention when setting this height, there are often protrusions in the casting that will not allow the End Mill to travel unobstructed all the way to the start of the lifter bore. It is safest to set the Start Boring Height above the Deck.

Lifter Bore Angle

Rottler has specific Lifter Bore spacers that are installed on the Cam bar to set the correct angle for lifter boring when using the Performance Fixture.

Lifter Bore 4th Axis

Lifter Bore programs are built the same as described in the Bore Mode 4th Axis. Only the differences will be discussed in this section.

Start Boring Height

Pay particular attention when setting this height, there are often protrusions in the casting that will not allow the End Mill to travel unobstructed all the way to the start of the lifter bore. It is safest to set the Start Boring Height above the Deck.

Lifter Bore Angle

The angle for each bank is located on the associated Locations page. Press the angle numerical value and a pop-up will open so you can type in the Lifter Bore angle.

Calculate In/Out

This button is located next to the In/Out Locations for each Bank. You must first have the Correct angle entered into the Angle data box. Then press the Calculate In/Out button. A window will open where you enter the center to center distance of the Cam to Crank bores. The In/Out locations will automatically be filled in.

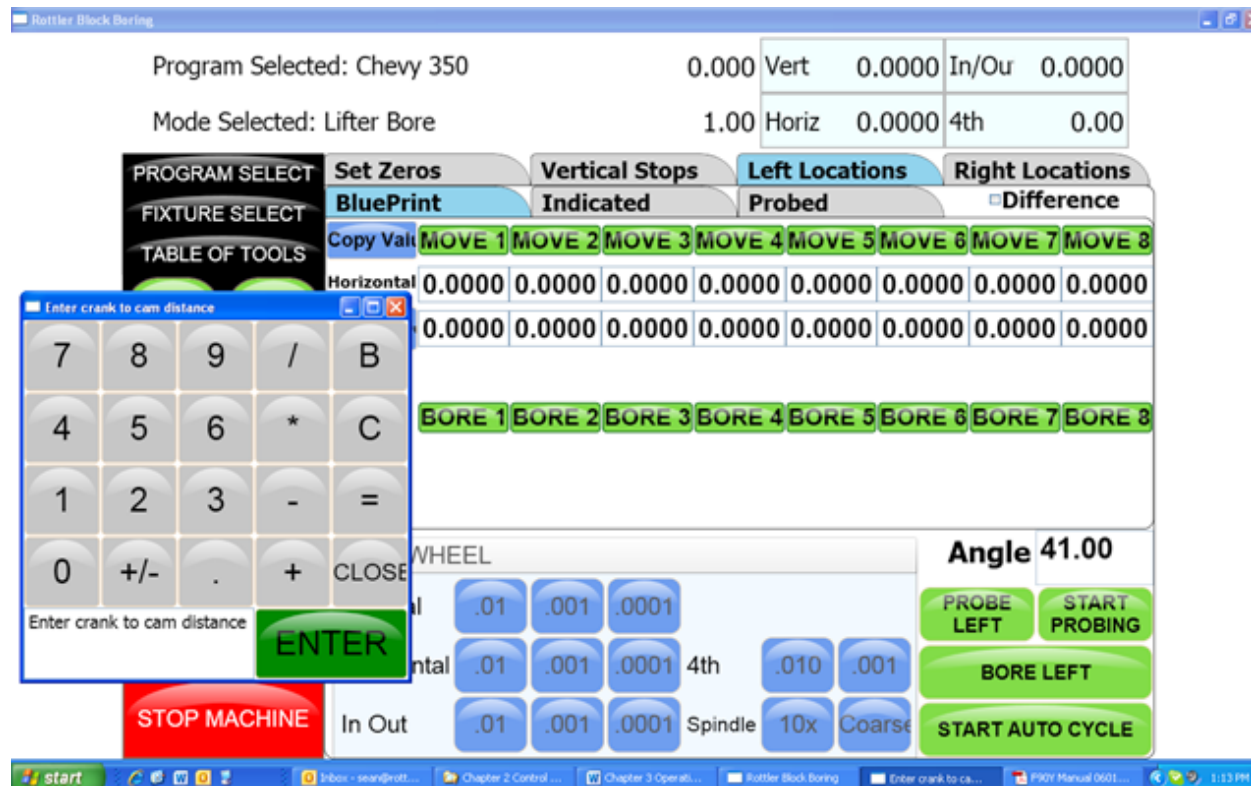

Line Bore Mode

Select the Line Bore button from the Main Menu. This will bring up the Line Bore Mode with the Set Zeros tab shown.

Mounting and Aligning the 90 Degree Head

Mount the 90 degree head onto the spindle and just snug the four mounting bolts. Use the following instructions to align the head.

Mount a .001" or .0001" dial indicator to the machine table or block. The 90 degree head has two machined surfaces that can easily be used to align the head. The two surfaces and indicator positions are shown below.

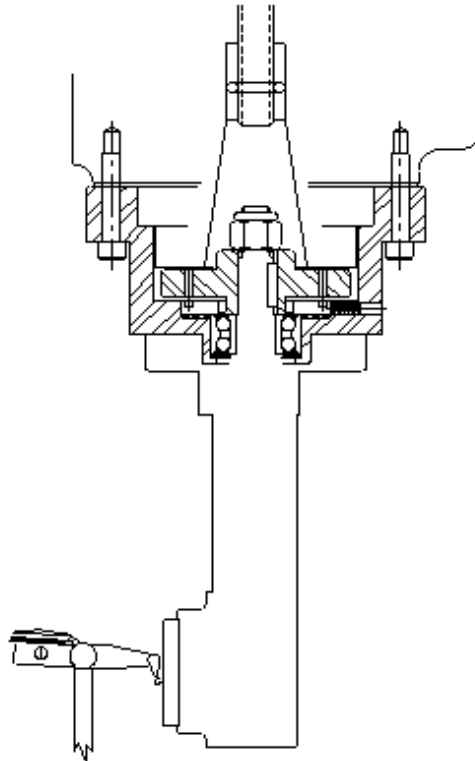

Put some pressure on the indicator. Using the In/Out handwheel move the indicator from one side to the other noting the amount of difference. Keep the indicator on that side of the head and rotate it half of the noted distance. Repeat this procedure until there is less than .0005" variance.

Tighten the four mounting bolts for the head and check the surface again to be sure it did not shift when tightening the head.

Setting Zeros

The purpose of setting zero points is to give the operator a specific point to build programs from. The machine also uses these zero points to run the program from. The zero points can be set at any point in the machines' travel. Each axis (except the Spindle rotation) will need to have a zero point set for the machine to operate from.

Horizontal Zero

The Horizontal should be set about .050" from the front of the first main to be bored, making sure that that position will allow the head to travel up without interference. Bring the head down and roughly center it in front of the first main. It does not need to be perfectly centered to set the horizontal zero. Press the Horizontal Zero button at this location.

In/Out and Vertical Zero

Locate the supplied Last Word indicator and small magnetic base. Mount on cutterhead as shown below.

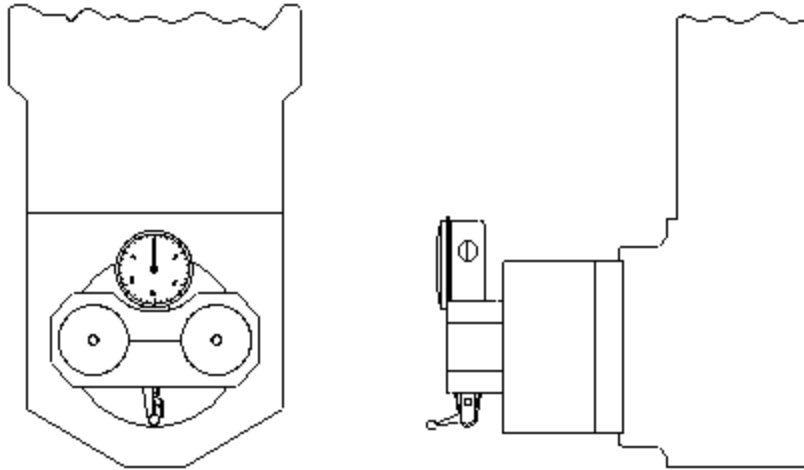

Using the Horizontal handwheel move the indicator inside the main bore, making sure the indicator is not touching the main bore at this point. You will be indicating both sides and the bottom of the saddle, generally the cap is not used to indicate from.

Physically move the indicator and mag base on the cutterhead until there is about .010" pressure on it. Start rotating the spindle CW and CCW watching the indicator. As there is too much or too little pressure on the indicator, use the In/Out and Vertical handwheel to adjust the spindle in the bore until all three points are equal. Press the In/Out and Vertical zero buttons at this point.

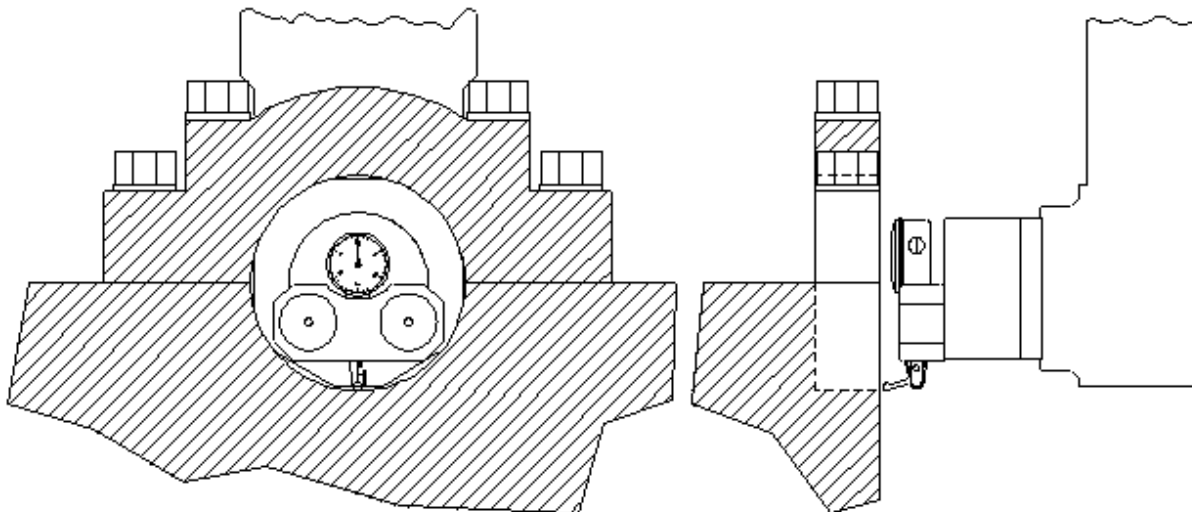

The Vertical stops have now been set. You are finished with the Program Vertical Stops screen, select the next Tab to the Right.

Programming Vertical Stops

To build a program you must set the Vertical Stops. There are two (2) vertical stops used in the Line bore mode.

Bore Centerline

The first vertical stop is on the main bore centerline. The vertical zero was set on the bore centerline, Therefore this stop will always be zero.

Block Clearance

This stop is set at a negative value that will allow the 90 degree head to travel over the cap and bolts to the next main bore unobstructed.

Programming Horizontal Stops

The Horizontal Zero was set .050" before the first Main Bore, so the first Horizontal stop will be 00.000. Measure the distance between each main and enter it into the corresponding stop number.

Programming Bore Length

Measure the length of each Main Bore and enter that value into the corresponding length box

Running the Auto Cycle

You will need to set a Feed Rate and Spindle RPM on this screen to run an auto cycle. After this is done press the "Move to Zeros" button. The spindle will move up the Vertical Block Clearance distance if it is not already there. It will then move to the Horizontal and In/Out axis to the zero position. The vertical will then move down to the zero position and stop.

CAUTION

If you press the MOVE buttons or the Cycle Start button the machine will not move the In/Out axis to the zero position. You need to move the In/Out axis to the zero position manually before you press Cycle Start.

The machine will go idle at this time. Pressing the "Start Auto Cycle" button will cause the entire cycle to run.

After a program has been completed the machine will move the spindle over to the first Main Bore at the Clearance Distance.

Thrust Cutting

Refer to Line Bore in this section for mounting the block and aligning the 90 degree head.

Note: It is important to read through the entire Thrust Bearing Cutting section before entering any values or starting the Auto Cycle. You will better understand how the program operates and how the values affect the operation of the Auto Cycle.

The Thrust Cutting program can cut a single or double thrust face using circular interpolation.

Select the Thrust Bearing Cutting button from the Main Menu. This will bring up the Thrust Bearing Cutting Bore Mode with the Set Zeros tab shown.



Setting Zeros

The purpose of setting zero points is to give the operator a specific point to build programs from. The machine also uses these zero points to run the program from. The zero points can be set at any point in the machines' travel. Each axis (except the Spindle rotation) will need to have a zero point set for the machine to operate from.

Horizontal Zero

To set the Horizontal Zero, bring the cutter in using the Horizontal Hand Wheel until it just touches off the current thrust face. Press the Horizontal Zero Button here. The computer will use this zero point when cutting the depth of the thrust face.

Follow the procedure for setting zeros in the Line Bore Mode section of this chapter. Set the Horizontal zero on the Main Bearing that is to have the Thrust cut.

After the zeros have been set select the nest tab to the right, Dimensions.

Dimensions & Auto Cycle

There are several values that need to be set on this screen for the program to operate properly. Below is illustration and a description of each of these values.



Thrust Dimensions

Outside

This is the Outside dimension of the thrust face to be machined.

Inside

This is the Inside dimension of the thrust face to be machined.

Cutter

This is the diameter that the cutting tool is set to.

Clearances

Vertical

This is the distance, from zero, the 90 degree head will have to travel up to clear the main caps on the block.

Horizontal

This is the distance, from zero, the 90 degree head will have to travel to clear the main for the next vertical move.

Dimensions

Main Width

Width of the Main.

Insert Width

Width of the Insert.

Left Depth of Cut

Depth of left cut.

Right Depth of Cut

Depth of right cut.

Cut Right Side

If you select Cut Right Side the automatic cycle will cut the thrust face on the right hand side of the Main.

Cut Left Side

If you select Cut left Side the automatic cycle will cut the thrust face on the left hand side of the Main.

Description and Running of the Auto Cycle

You will need to enter the Feed Rate and Spindle RPM the program will run at.

There are no Move to buttons in this program. You MUST be at the zero positions when the Auto Cycle is started.

Start Auto Cycle

When you are at the zero positions press the Auto Cycle, the spindle will start at the programmed RPM. The vertical feed will start at the programmed rate in an upward direction until the correct Outside diameter is reached. The circular interpolation will start at this point and go 360 degrees. It will then continue the circular interpolation back towards the center of the Main to clear the cutting tool from the thrust face. When the cutterhead is back at the center point (zero positions) of the Main, all motion will stop. The cutterhead will then rapid travel to the left taking the main width and the cutter diameter into account to reach the correct depth on the second thrust face. The same circular interpolation process will then be repeated for the second face. The cutterhead will then retract horizontally to the clearance distance then vertically to the block clearance distance.

When the program is running the "Start Auto Cycle" button will change to "Press to Pause". If this button is pressed the machine will pause the program right where it is. At this point the screens are locked out from changing anything. The button will change to "Press to Resume". If you want to resume press the button and the program will continue from that point on. If you do not wish to continue press the "Stop" button. This will put the machine back in idle mode and changes can be made to the program.

Cam End Tunnel Boring

To bore the end tunnels on a block refer to Block End Truing Fixture 650-3-30 when used with Cam Boring for set up the block. Select a Cam bushing that will fit the existing Cam bore and place it in the Cam Spacer. Place the distributor end of the block facing up. You will need to be in the Bore Mode on the control panel.

Center the spindle over the Main bore using the electronic probe or magnetic base with indicator. Zero the Horizontal and In/Out axis.

The Cam spacer placed in the center T-Slot should put the Cam tunnel in line with the Main bore.

Move the table the specified distance toward the Cam Tunnel. This distance should in the blue printing specifications for the block you are working with.

Check that you are on center of the cam bore with the electronic probe or indicator. If it is not on center the block may have been previously bored or honed incorrectly.



Be very careful when correcting the existing Cam bore on the In/Out axis. This could cause the distributor gears to be damaged.

You can also skip the above procedure and center on the existing Cam bore.

Once centered on the Cam bore or set to correct the Cam bore, zero the Horizontal and In/Out axis.

Install the 650-2-3F cutterhead into the spindle.

Refer the Bore Mode, Programming Vertical Stops earlier in this chapter to set the vertical stops.

Note: It is important to bore the Cam End bores the full length of the cutterhead on both ends. If you do not you may have trouble getting the Cam Bar to bore the full length between Cam End Bores.

Hint: It is helpful and more efficient to have three (3) tool holders set up for this procedure, two (2) of them for large material removal and one for a finish pass of .020" to .030".

Bore the distributor end Cam bore.

Note: To bore the oil groove in the Cam Bore, refer to the Cam Bore Oil Groove section in this chapter.

This is a CNC operation.

Remove the block from the fixture, select a Cam bushing that will fit the bore that was made on the distributor end of the block.

Rotate the block so that the distributor end is now facing down. Tighten the block into the fixture. The Cam spacer will put the end bores in line.

Press the move to zeros button.

Bore this end off the block.

Remove the block and the fixturing from the machine.

Refer to Cam Tunnel Boring in this chapter to bore the center tunnel of the Cam.

Cam Tunnel Boring

To bore the center of the Cam tunnel refer to Cam Tunnel Boring in the Block Mounting section of this chapter. Mount the block as shown.

The following illustration shows the cutting tool and holder and how they are set inside the Cam Boring Bar.

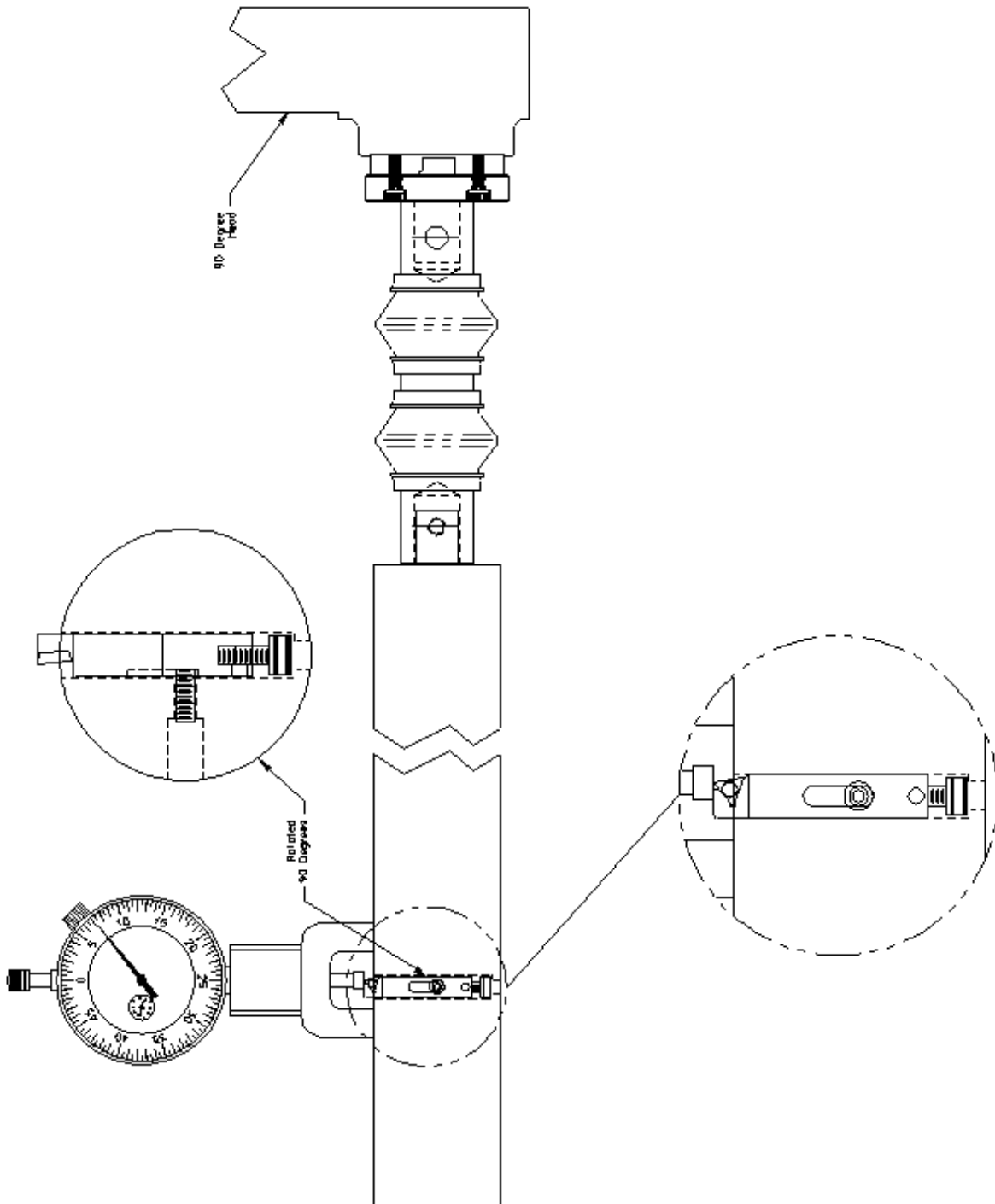

Zeroing the Micrometer

Remove the magnet keepers from the bottom of the indicators magnetic base. These should be put back on when the magnet is not in use to keep the magnet strong.

Place the magnet on the smooth portion of the bar next to the tool holder hole. Set the zero on the indicators dial, noting the number of revolutions the dial has made.

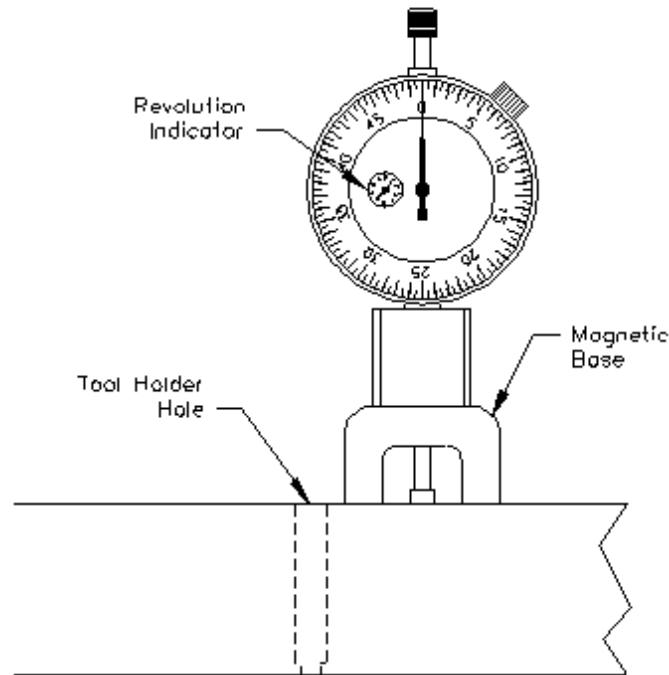

Setting Cutting Size

The diameter of the Cam Bar 650-2-32D is 1.7500". The 8-32 X 1/2" socket head cap screw on the back of tool holder is used to adjust size. When the tool holder is inserted into the Cam Bar the cap screw goes against a ledge inside the Cam Bar. When the cap screw is turned in the size will get smaller. When the cap screw is turned out the size will get bigger.



When adjusting the size on the tool holder, you must remember that the amount that will be taken off of the diameter will be twice the reading on the dial indicator.

When the dial indicator reads zero the bar will cut 1.7500". Double the amount past zero on the dial indicator and add that to 1.7500" to determine the cut diameter.

Once the size has been set, lock the set screw in the Cam Bar to secure the tool.

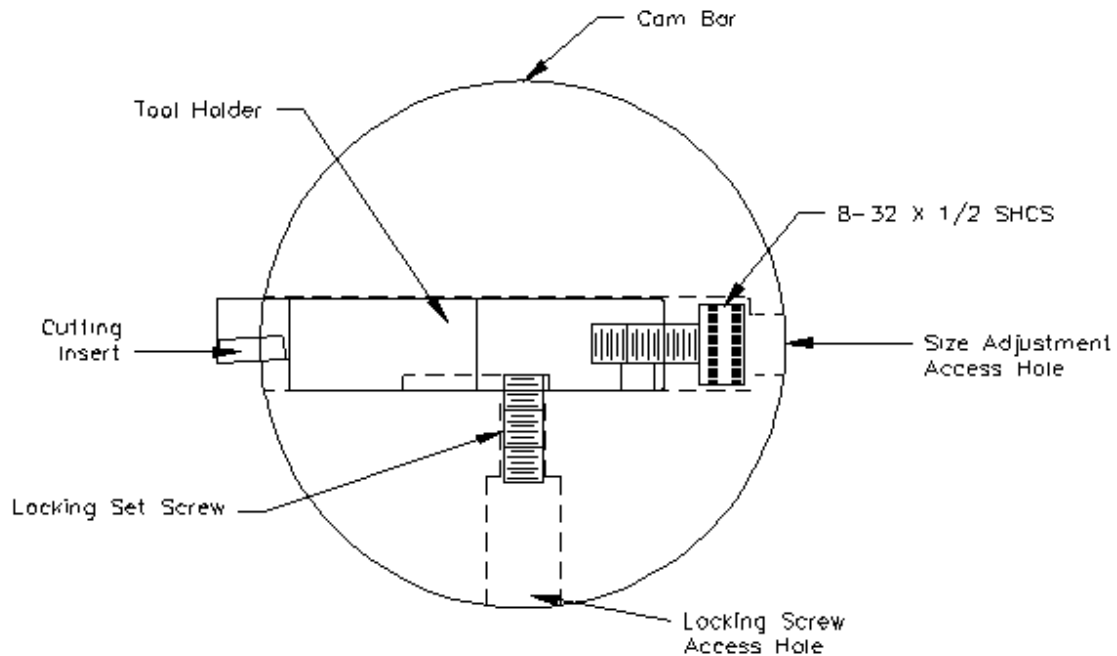

Refer to the Line boring section of this chapter for mounting and alignment of the 90 degree head.

Select Line Bore Mode of operation.

Mount the dual flex coupling to the 90 degree head with the two (2) supplied socket head cap screws.

Install one Cam Bearing Locator into the left side of the block.

Slide the Cam Bar into the Cam Tunnel and then into the right side locator. Keep the end of the Cam Bar with the adapter on it to the right.

Slide the second locator onto the Cam Bar, then the locator into the Cam Bore. The cutting tool needs to be between the two (2) locators.

Bring the 90 degree head down and line up the end of the dual flex coupling with the adapter on the Cam Bar. This does not have to be a precise line up, the dual flex coupling will take care of any alignment variance. Tighten the socket head cap screw on the dual flex coupling on to the adapter on the Cam Bar. Press the Vertical, Horizontal and In/Out zero buttons.

Final set up should look like the drawing on the following page. The mounting components are not shown on this drawing. Refer to the block mounting section of this chapter.

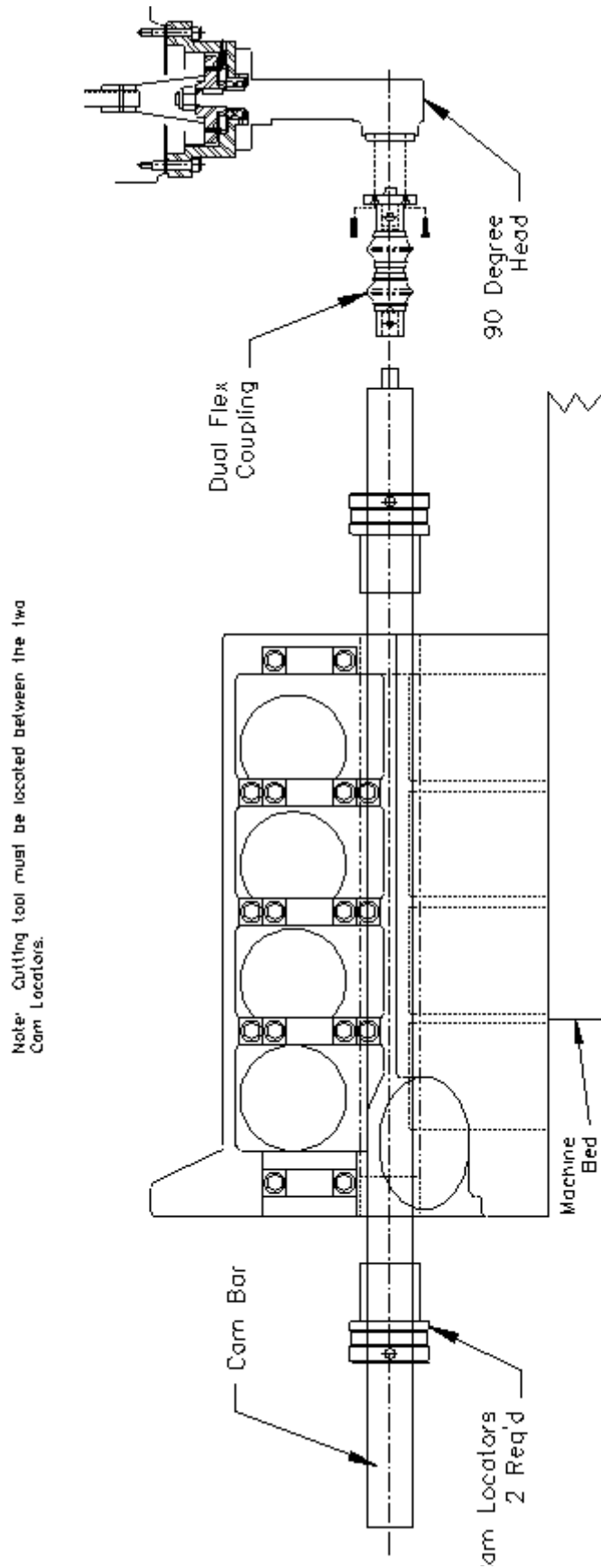

Setting Vertical Stops

Make sure the machine is at the zero positions as described previously.

When using the Line Bore Mode to do the Cam Tunnel boring the vertical stops described here will never change. They must be used to run an a cycle without damaging parts.

Block Clearance: -.001
Block Center Line: 00.000

Setting Horizontal Stops

All of the Horizontal stops are to remain at 00.000 when using the Line Bore Mode to do Cam Tunnel boring. The only setting that gets changed on this screen is the Bore Length for Horizontal stop 1. This will be the distance between the two (2) end Cam bores that needs to be bored out.

Auto Cycle

You **DO NOT USE** the Auto Cycle when Cam Tunnel boring. The only items that get used on this screen are the Feed Rate and Spindle RPM.

Recommended feeds and speeds will be discussed later in this chapter.

Manual Bore

This screen is used to bore the Cam Tunnel. With the Horizontal and the In/Out axis at the zero position and the Vertical at or above the Block Clearance Height, Press the BORE1 button.

The spindle will do a rapid move down to the Block Center Line position (this is only .001 so will not notice the move). The spindle and Horizontal feed will start at the programmed speed. The machine will continue boring horizontally until the horizontal position set in the Bore Length is reached. The Vertical will retract .001 and the horizontal will retract back to the zero position.

Recommended Boring Procedure

The three (3) tool holders included in this package should be used as dedicated holders. Two of them set for roughing passes and the third set for a final finish pass.

It is recommended to set the first two tool holders for a .100" pass each, then set the third tool for the finish size.

Size is not critical on the first two passes, these tools can be set and not adjusted for each use. The third tool should be checked with the dial indicator for final size each time you use it.

Recommended Feed Rate: .001 - .003
Recommended Spindle RPM: 300 – 500

IMPORTANT: You should put a light coating of light weight oil on the Cam Bar to prevent it from seizing up as it goes through the Cam Locators. At higher spindle speeds the bar heats up more.

Con Rod

Manual Screen

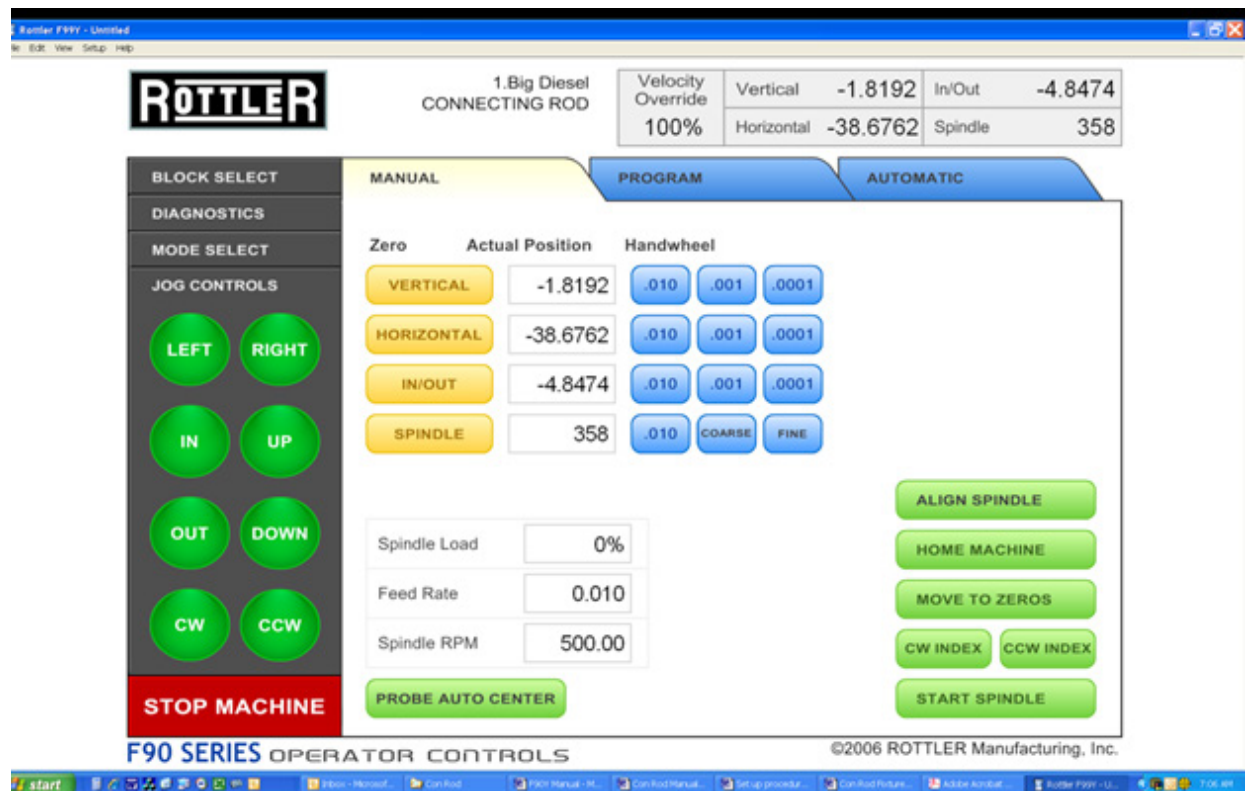

This screen is used to set the center of the conrod to be bored and a vertical height reference for the cutterhead and boring tool to be used.

Setting In/Out and Horizontal Zero

Using a suitable Magnetic Base and Indicator assembly as shown below, indicate in the center of the conrod and touch the Yellow Horizontal Zero and In/Out Zero Buttons to set the machine to the center of the conrod. Normally only the conrod half of the big end is used for centering. When setting the In/Out Zero, the last movement of travel when indicating the bore of the conrod, must be in the inwards direction. When setting the Horizontal Zero, the last movement of travel when indicating the bore of the conrod, must be in the leftwards direction. This will eliminate any backlash that may be in the machine.

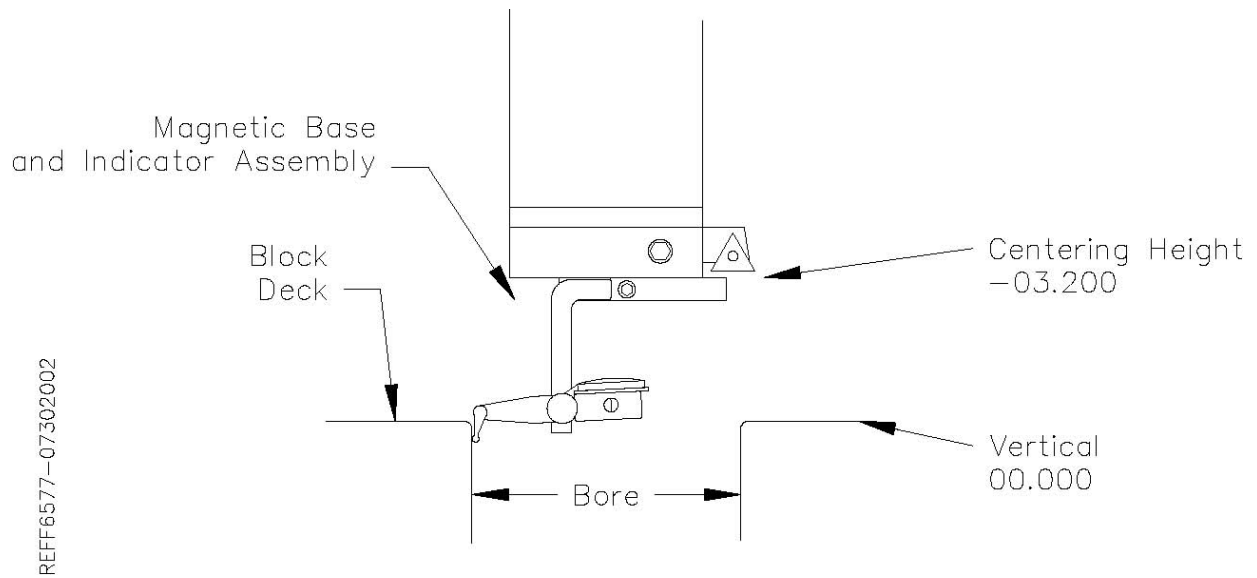

Setting Vertical Zero

Fit the cutterhead and boring tool that is going to be used to bore the big end. Once the Horiz and In/Out center has be established, slowly lower the cutterhead until the boring tool just makes contact with the thrust face of the big end of the conrod. At this point, press the yellow Vert Zero button.

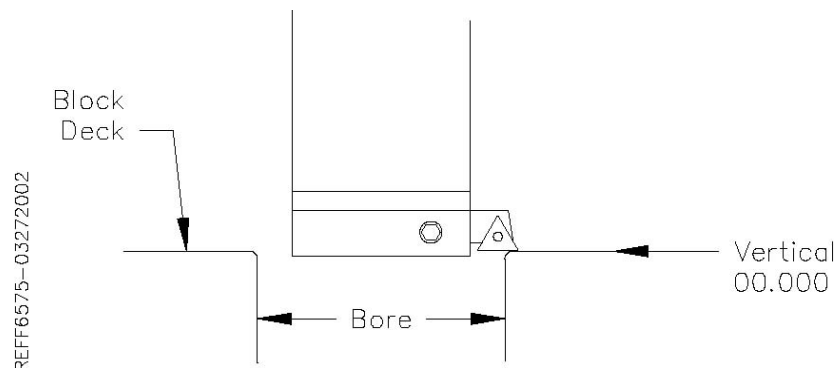

Program Screen

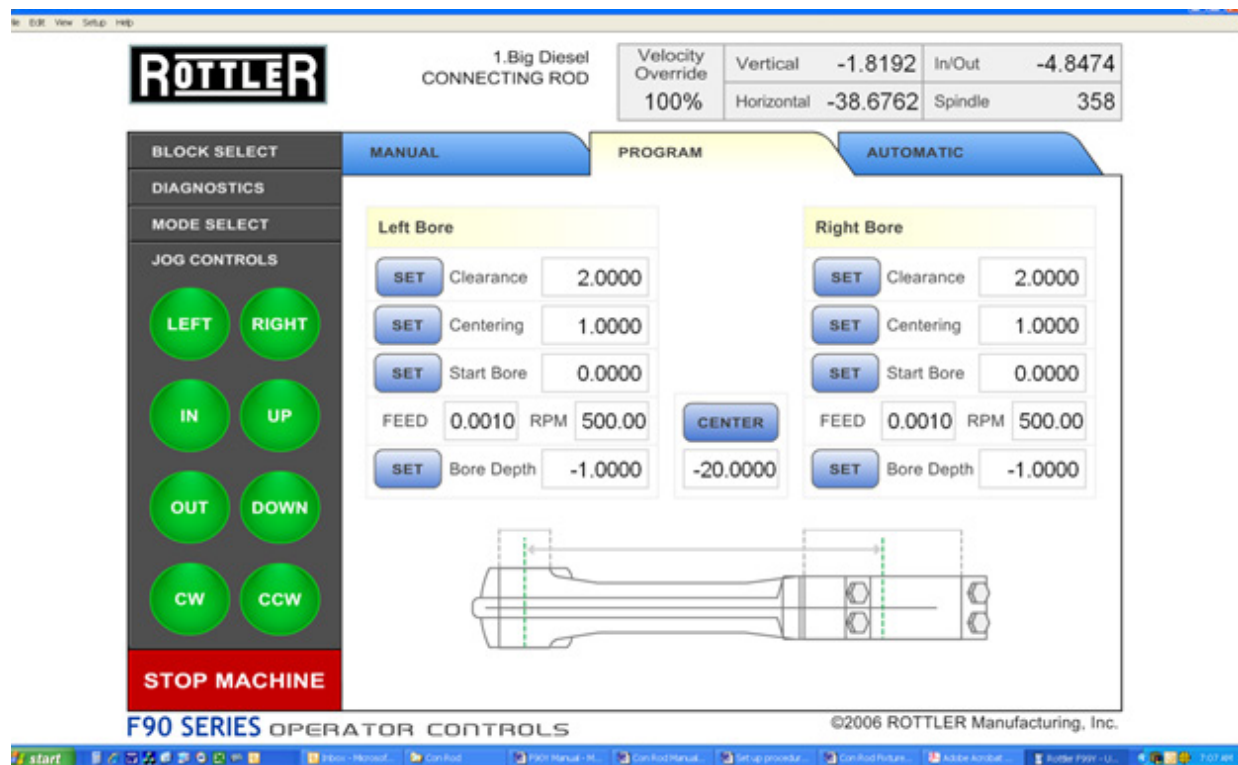

This screen is used to input all the parameters for boring both the big and small end of the rod plus setting positions for centering and measuring.

Measure

This allows a position to be set where the conrod will move to be able to measure a bore easily without interference of the cutterhead, this is normally set to move the conrod away from the machine towards the operator.

Clearance

This is the vertical height of the cutterhead with reference to vertical zero to where the cutterhead will move before any horizontal movements take place.

Centering

This is the vertical height of the cutterhead with reference to vertical zero to where the cutterhead will move in order to center the bore with a dial gauge.

Start Bore

This is the vertical height of the cutterhead with reference to vertical zero to where the cutterhead will move to start boring the conrod. This is set about .040" (1mm) above the side of the conrod bore.

Bore Depth

This is the vertical height of the cutterhead with reference to vertical zero to where the cutterhead will stop boring, index the boring tool to the right, move the conrod to the right for tool clearance then rapid the cutterhead upwards to the clearance position.

Center Set

This is where the center to center distance of the big end and small end of the rod can be programmed.

Automatic Screen



This screen is used to run programs such as bore right big end of the conrod. When the green buttons are touched, the machine will move to the position or start an automatic cycle.

Bore Both: If special cutterheads with big and small end tooling in one are being used, the block can be checked so that the machine will bore both big and small end in one cycle. Normally the big and small ends are bored with different cutterheads and this block will be unchecked.

Note: *Do not stop an automatic cycle in mid cycle and then try to start it again. The CNC code running behind the Rottler screens use offsets in the controller. If the machine is stopped during an automatic cycle the machine must be shut down and restarted to clear the offsets. Otherwise the displayed position and actual position of the machine will not be correct.*

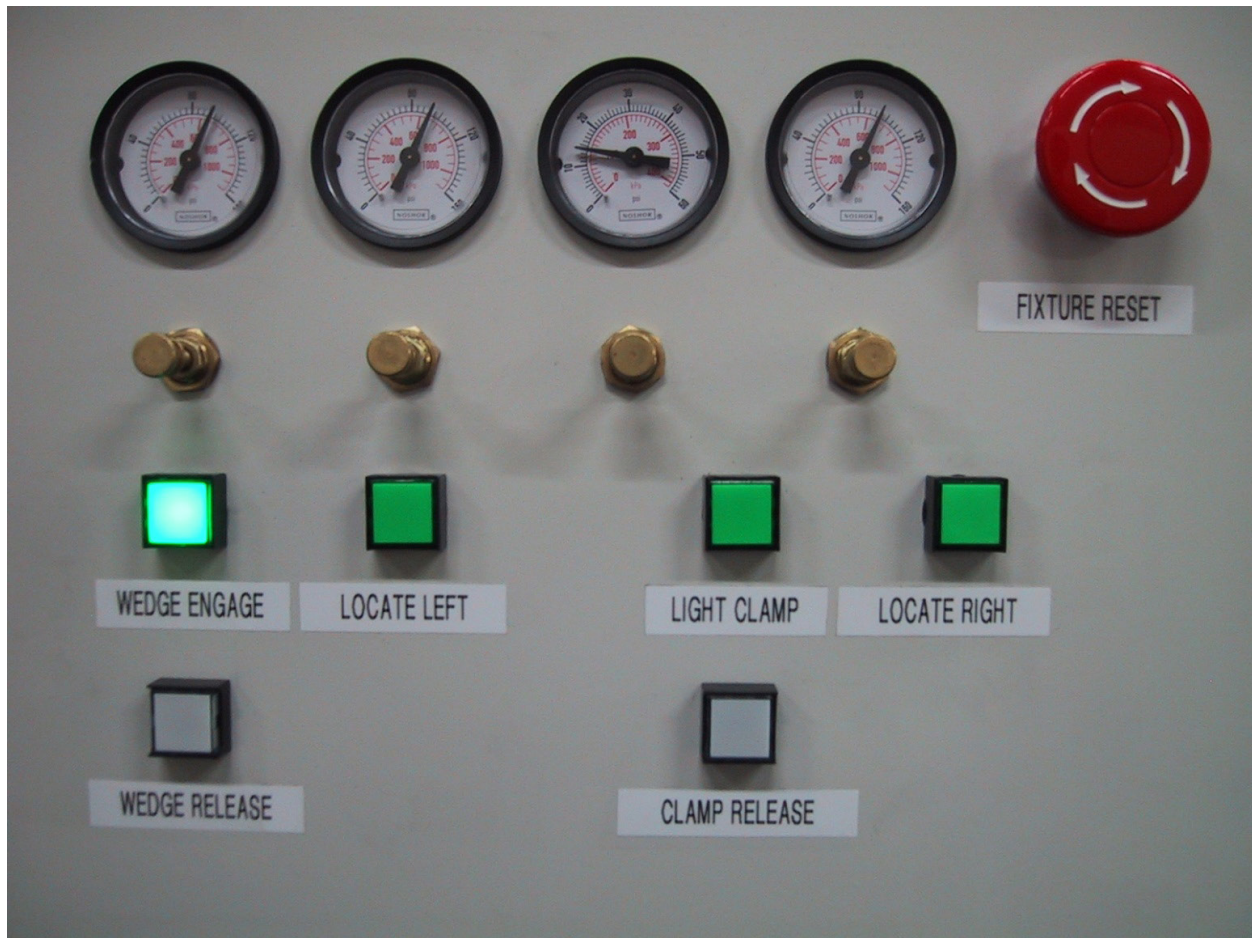
Fixture Control Panel**Set up procedure for conrod fixture**

Select the widest big and small end ball locators that will fit inside the conrod big and small end bores. Press Locate Right and the right hand ball locator will move up and stop against it's end stop, then remove the air pressure supply to the conrod fixture so that the ball locator pivot arms may be moved manually.

Fit the selected ball locators to the right and left hand mounting positions. Be sure there are no chips and that the locators fix exactly in their mounting positions.

Connect the air pressure to the fixture.

Press Locate Right Button, the right hand ball locator will move up and stop against it's end stop.

Select the correct conrod support and place across the conrod fixture.

Place the conrod to be bored into the fixture so that the big end bore touches both the balls of the right hand ball locators.

Adjust the conrod rest so that the rod lies approximately horizontal.

Adjust the 3 big end support pads so that each support pad locates on the side of the big end and does not protrude into the big end bore. This will require removing and refitting the conrod to be sure the 3 support pads are correctly located and their hold down cap screws are tight. Readjust the conrod support to allow the conrod to lie horizontal with no rock or tilt of the conrod on the 3 big end support pads.

Remove the conrod from the fixture.

Press locate left and the left hand small end ball locating device will lift up.

When the left hand ball locating device is at it's end of travel, place the conrod back in the fixture and adjust the left hand slide assembly so that both the left hand locating balls contact the bore inside the conrod small end.

Remove the conrod from the fixture.

Slide the left hand locating assembly approx 1/2" (12.7mm) to the right and lock both hold down handles securely, this will ensure that the small end ball locators contact the small end with some preload.

Place the conrod in the fixture.

Position the clamp arms so that their feet are approx 1/8" (3mm) above the side of the big end, be sure that they do not protrude into the big end bore to be machined and adjust their travel limit stops and lock the lock nuts.

Press the Light Clamp button, this will place light clamping pressure on the clamp arms and lightly hold the conrod down against the 3 support pads under the big end of the conrod.

Press the Locate Left button, the small end ball locator will move up and contact the bore of the small end of the conrod and firmly press it against the big end and straighten the conrod along the center of the fixture.

Select a set of wedges that will allow the outside of the small end of the conrod to be supported during boring so that there is no chatter or vibration during boring.

Press Wedge Engage button, the wedges will be pressed against the outside of the small end.

The conrod is now ready to be bored.

Air Pressure Settings

Right Hand Side Air Gage:	Locate Right	100psi	(6.5Bar)
Second from Right Hand Side:	Light Clamp	15psi	(1.0Bar)
Second from Left Hand Side:	Locate Left	30psi	(2.0Bar)
Left Hand Side Air Gage:	Wedge Engage	30psi	(2.0Bar)

Backing Up and Restoring Block Profiles

This section will explain how to back up and restore the operator created block profiles for DM controlled machines for archival purposes or to transfer to a different machine.

First step is to open your file browser and locate the RottlerWPF file on the C disk drive.

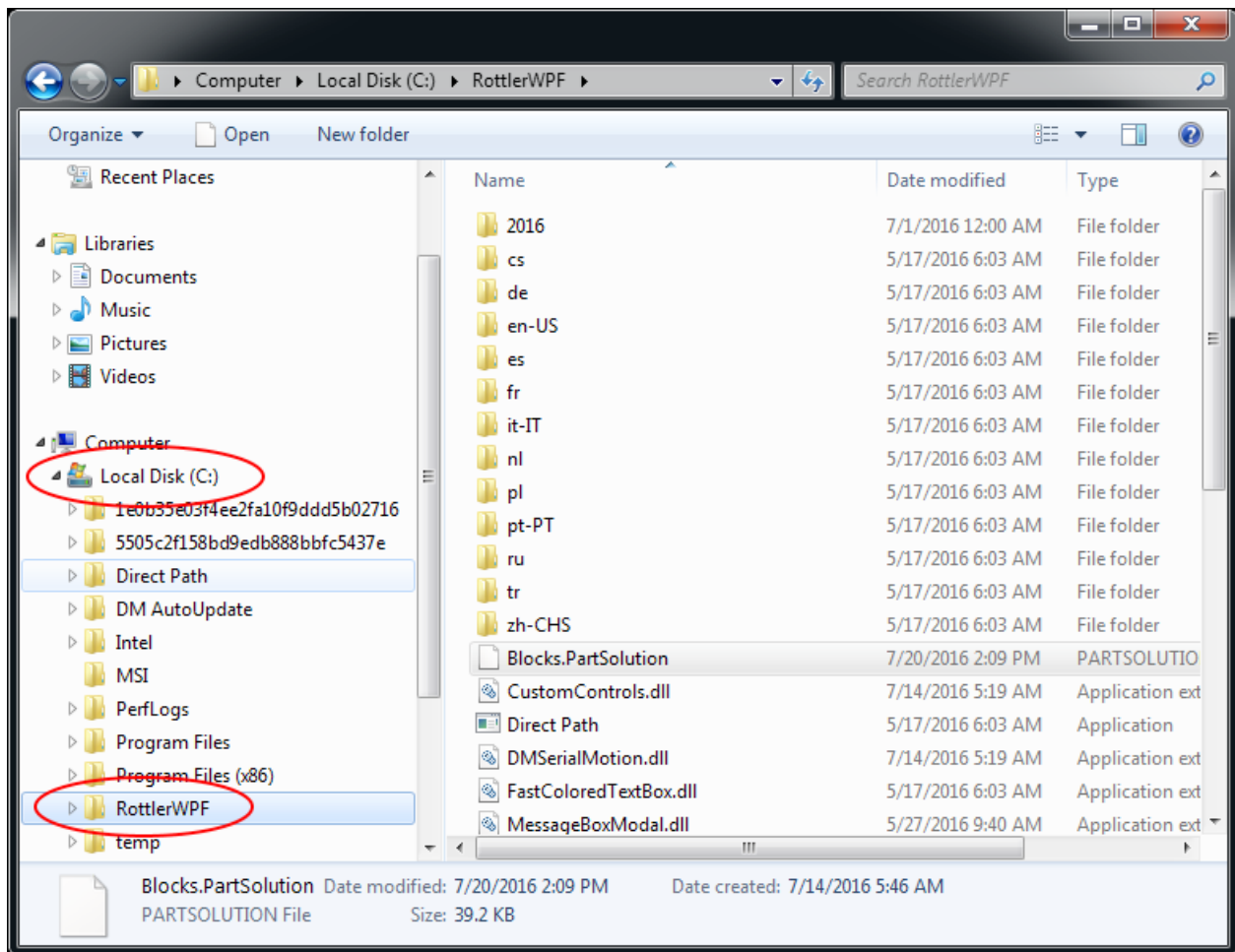

The next step is to plug in a flash drive to an open USB port



The following pop up box will appear on your screen.

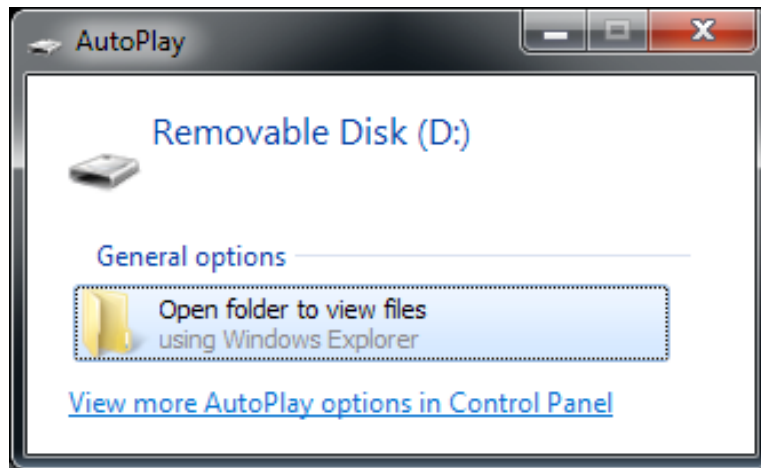

Click on the Open folder to view files option and the following screen will appear. This is the contents of the flash drive you just plugged in.

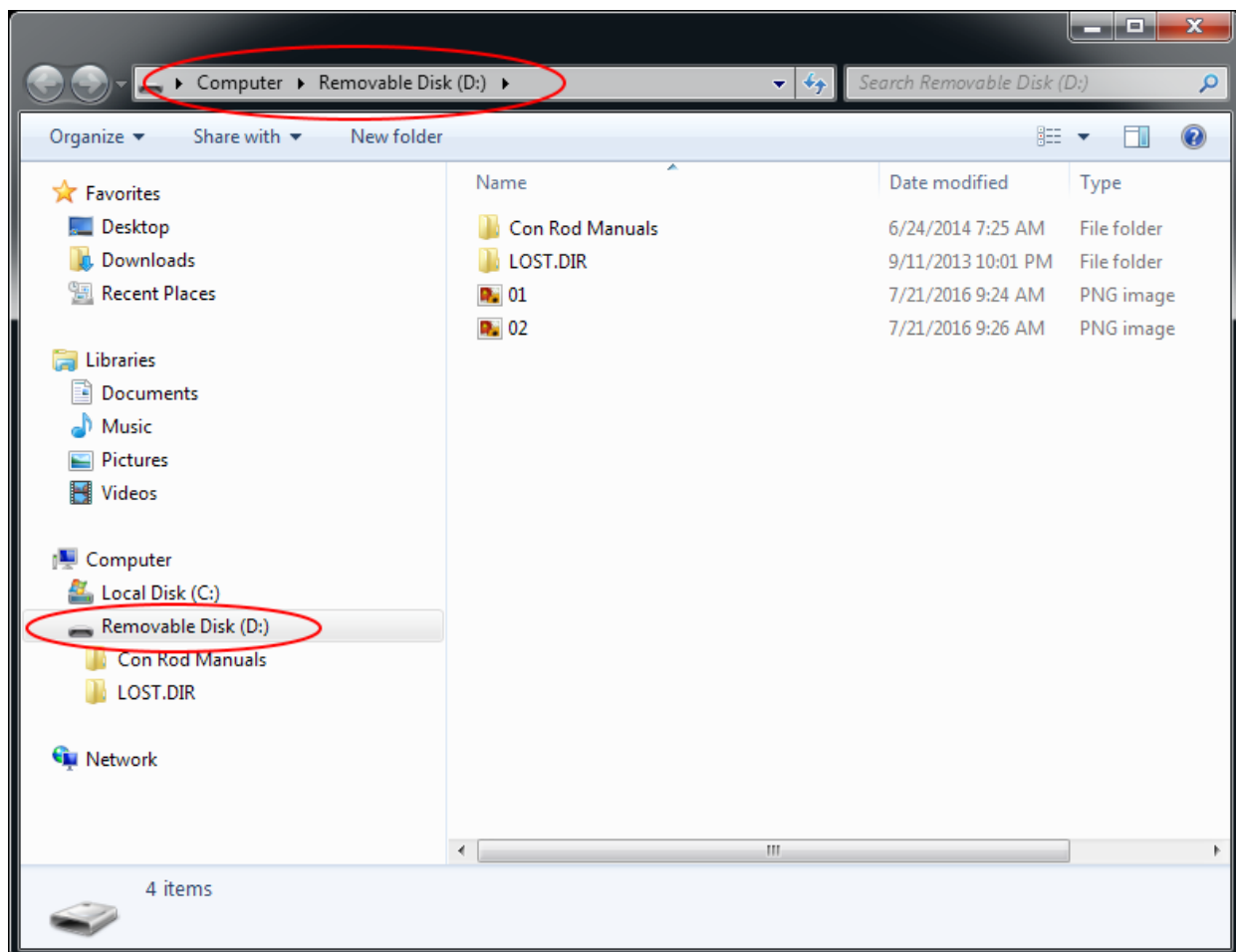

Next resize and arrange both file browsers so that they are side by side.

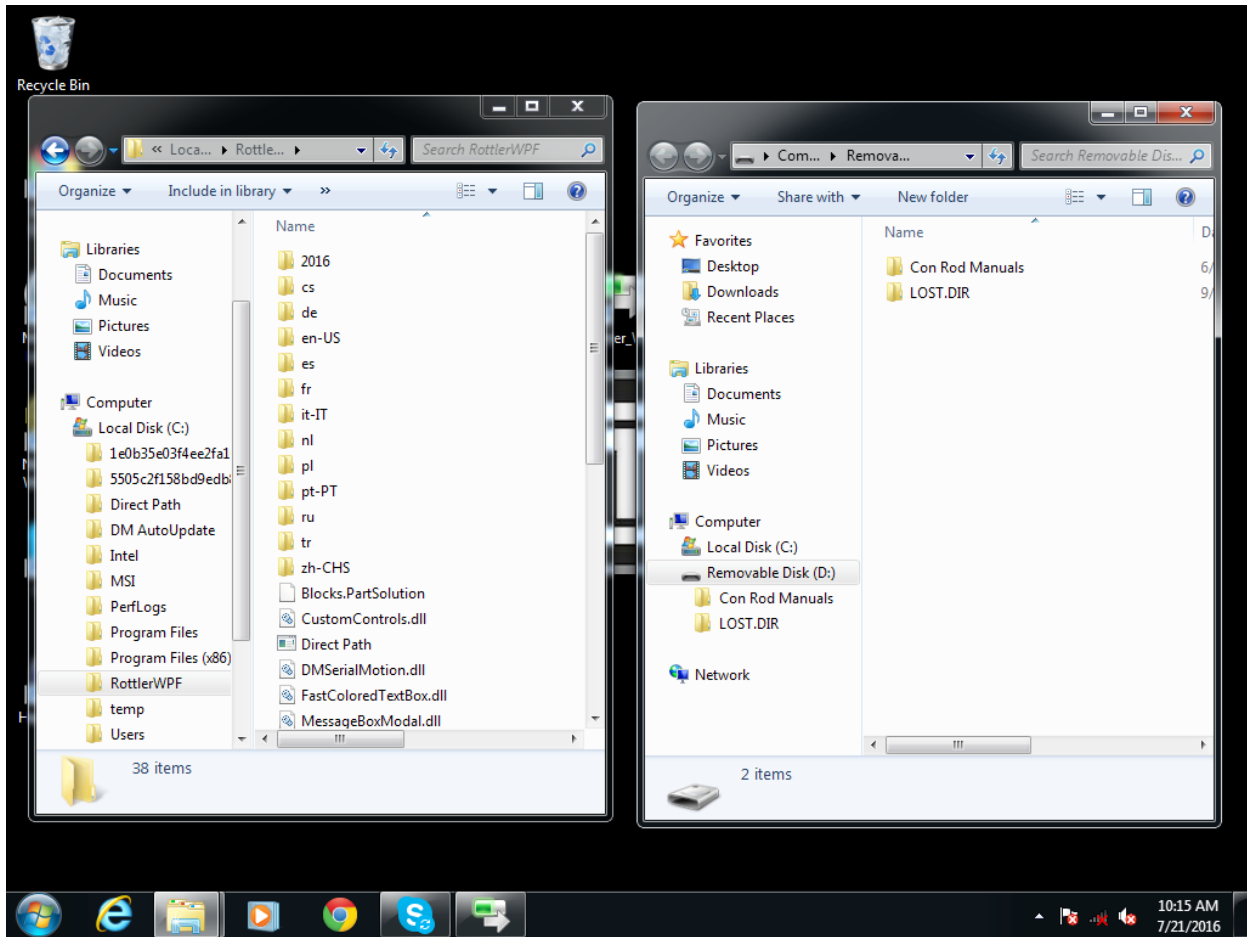

Block profiles are backed up each time the machine is run with the current profiles being shown in the RottlerWPF folder. All that needs to be done to back up the current profile is to simply drag it from the RottlerWPF folder to the flash drive folder. A copy of the file will be placed on the flash drive.

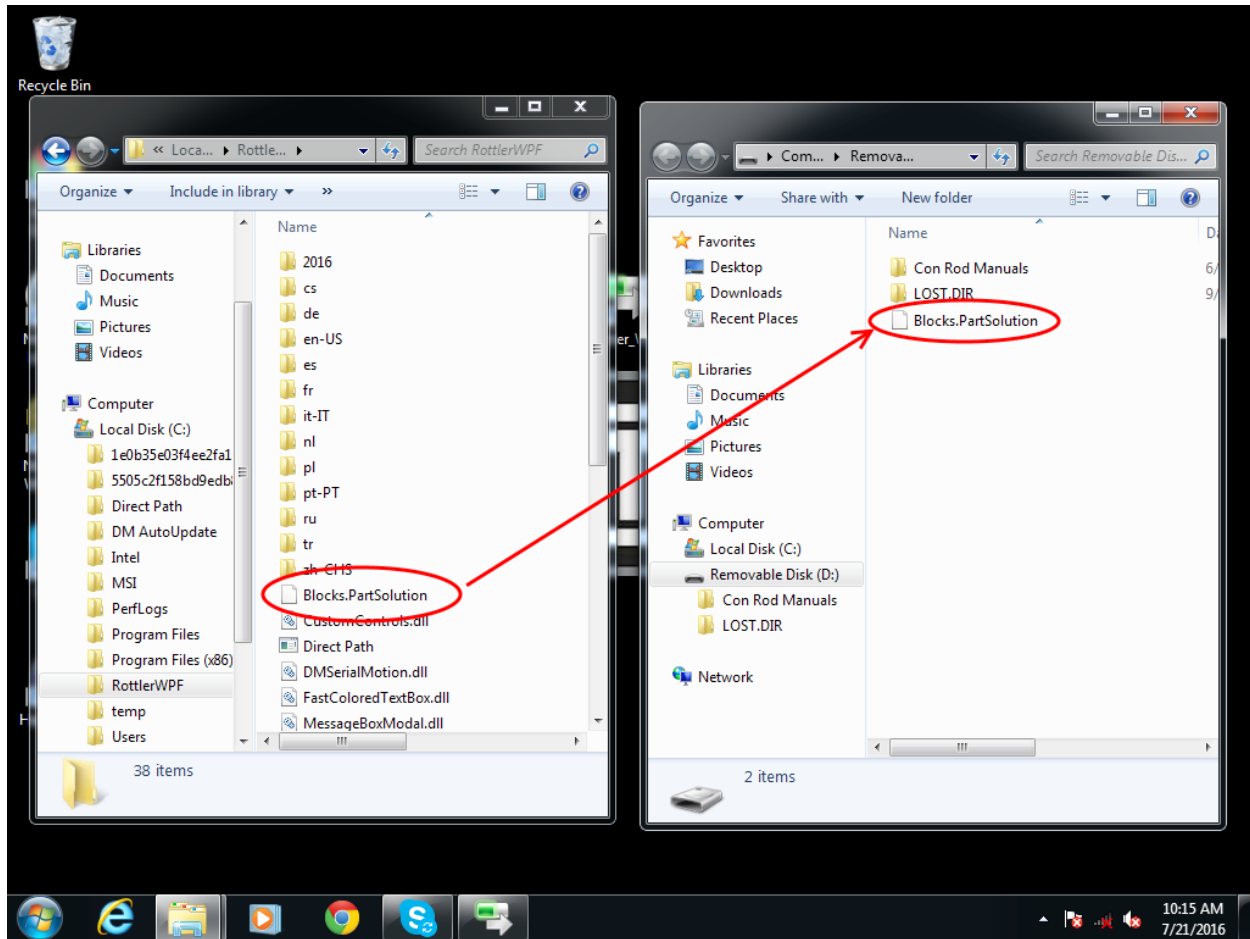

Backup is now complete. Close both file browser windows and remove the flash drive.

To restore or add block profiles go through the first 5 steps explained previously.

Highlight the block profiles file in the flash drive and drag it into the RottlerWPF folder on the local hard drive.

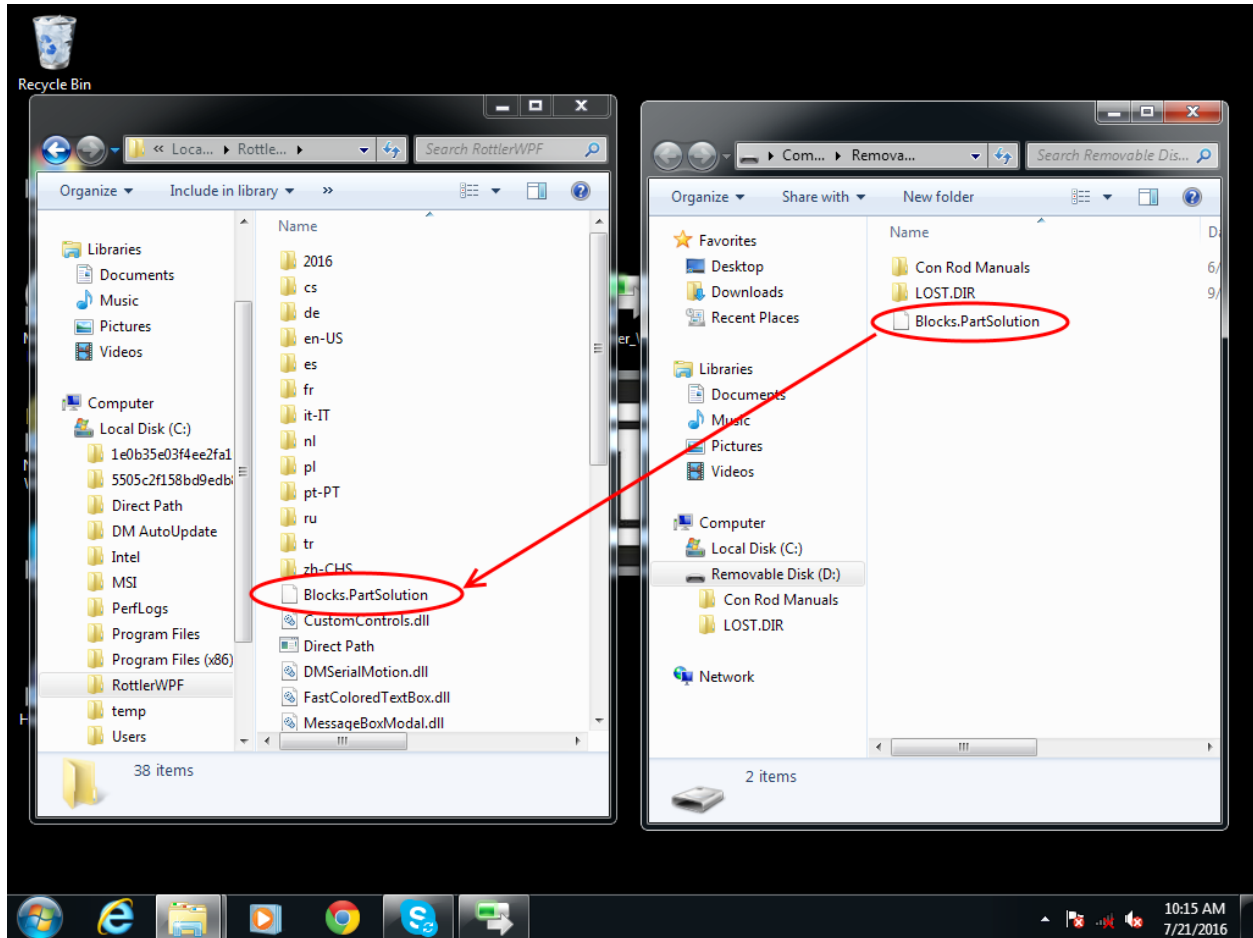

You will get a pop up window about there being a file of the same name in the destination folder. Click on the Copy and Replace option.

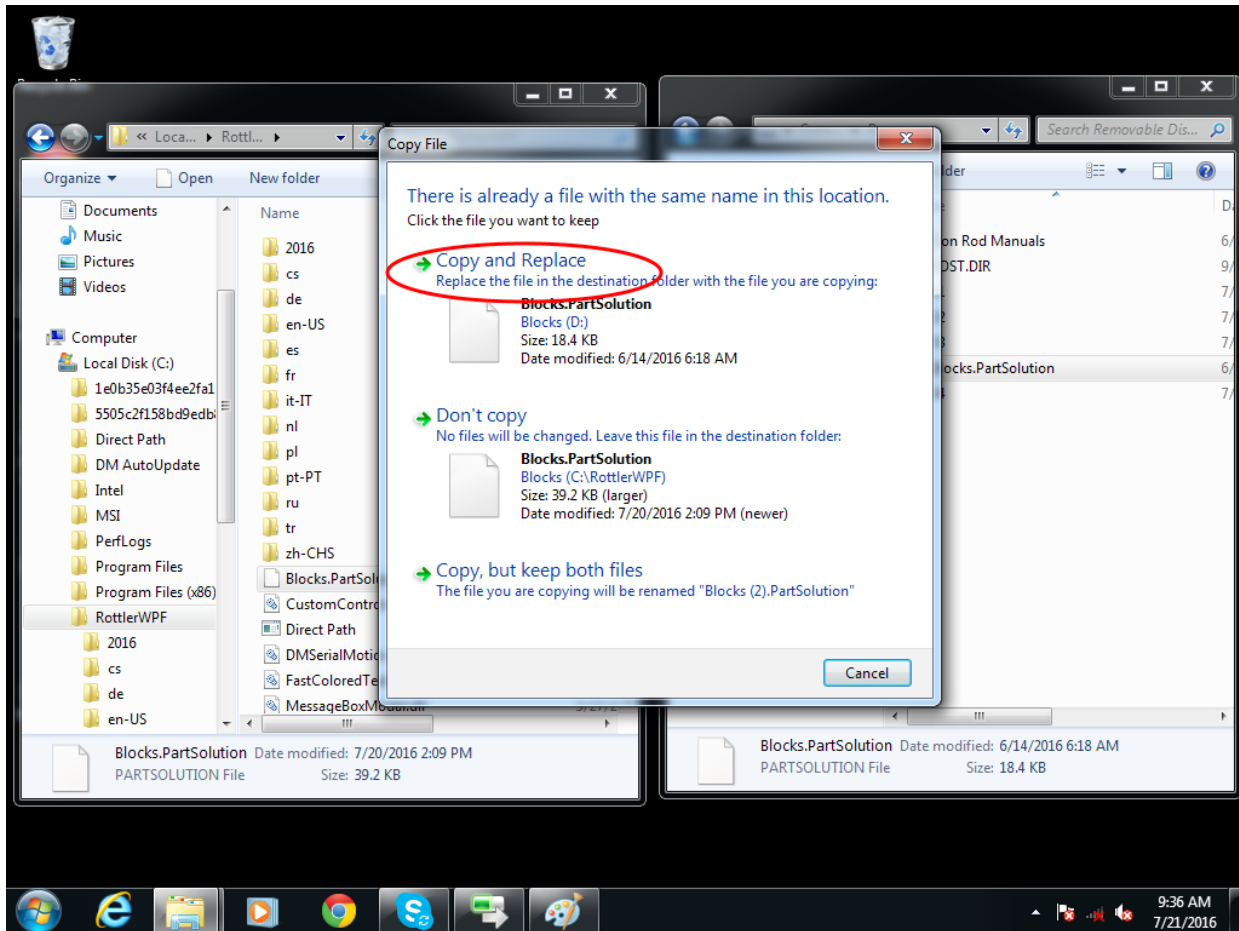

The archived block profiles will now be installed.

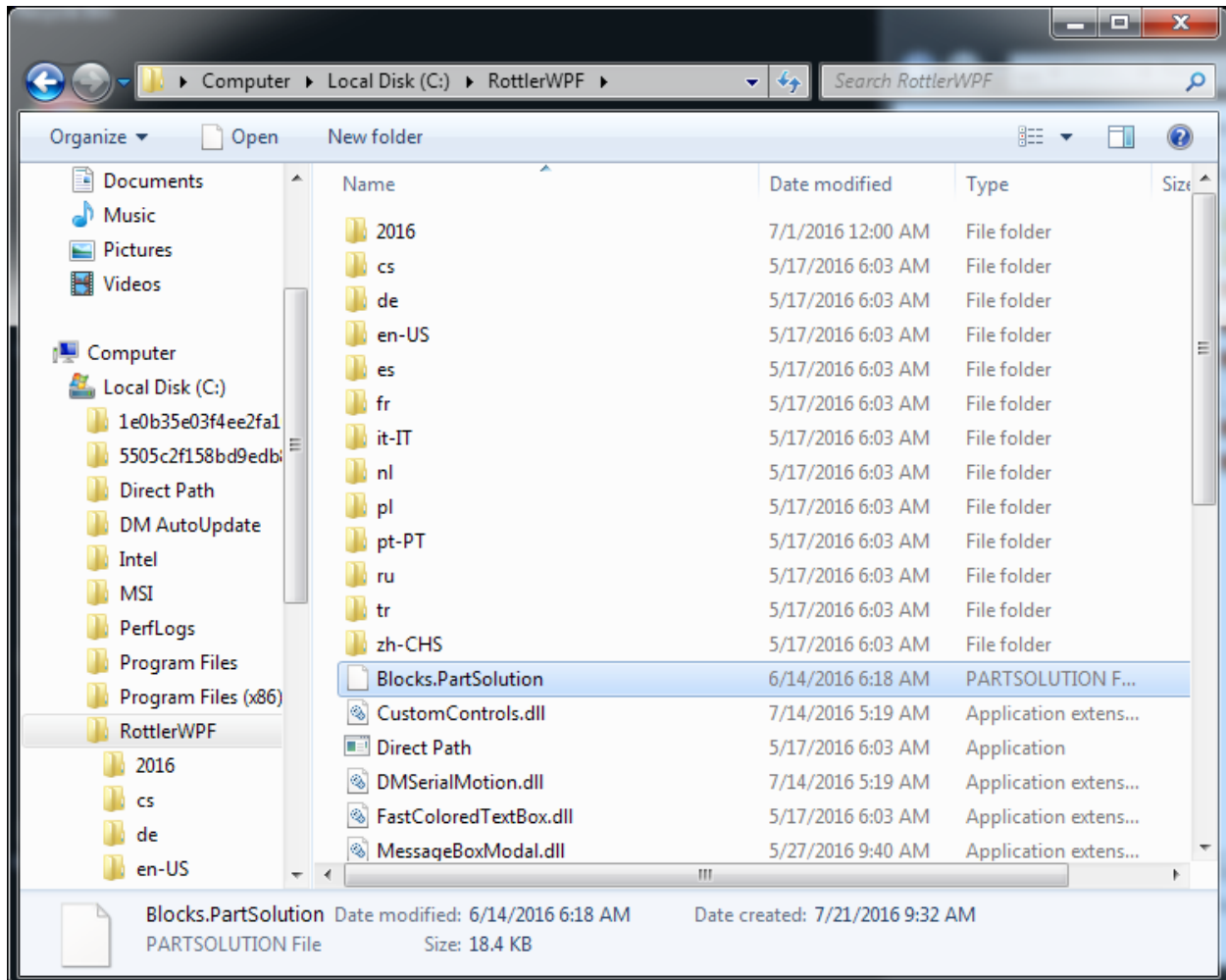

Close both browser windows and remove the flash drive. The restore process is now complete.

Backing Up and Restoring RCam Programs

Click on the Windows icon and type “hidden” in the search box.

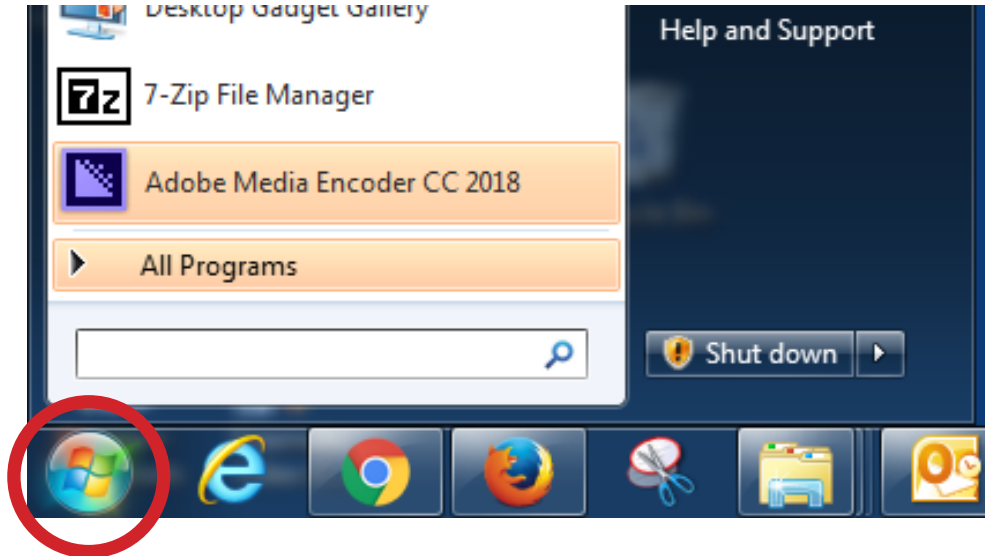

When the search results appear, click on the Show hidden files and folders option.

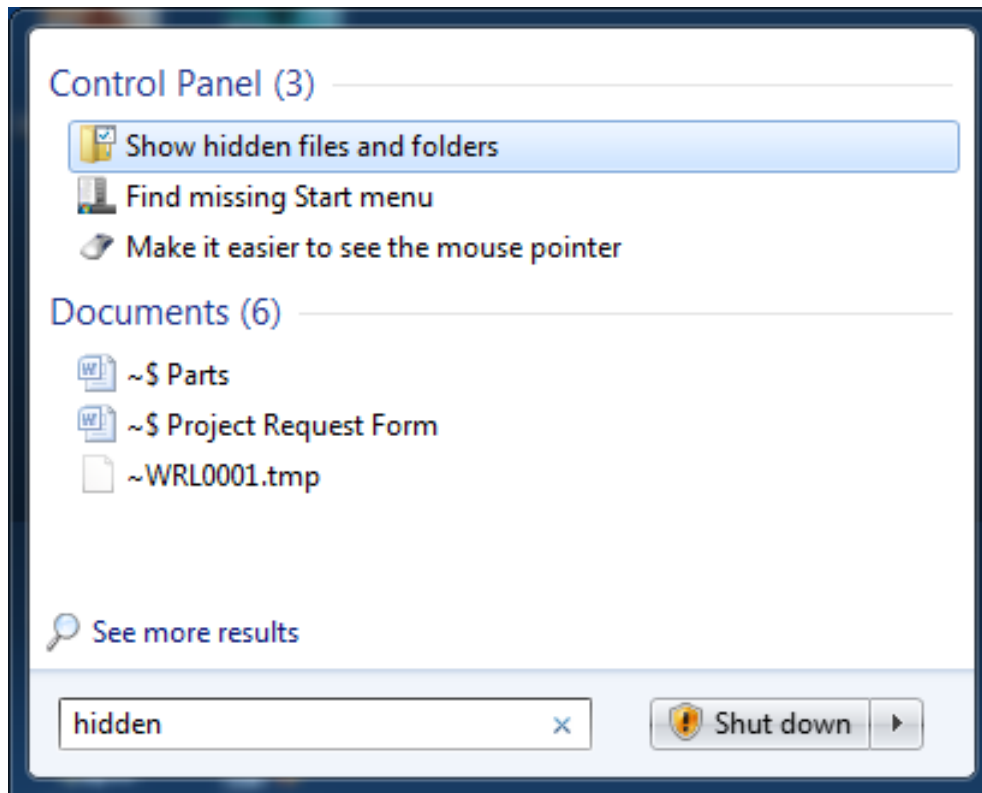

The Folders Options box will appear. Click to on the Show hidden files, folders, and drives to activate the option. Click on Apply, then OK.

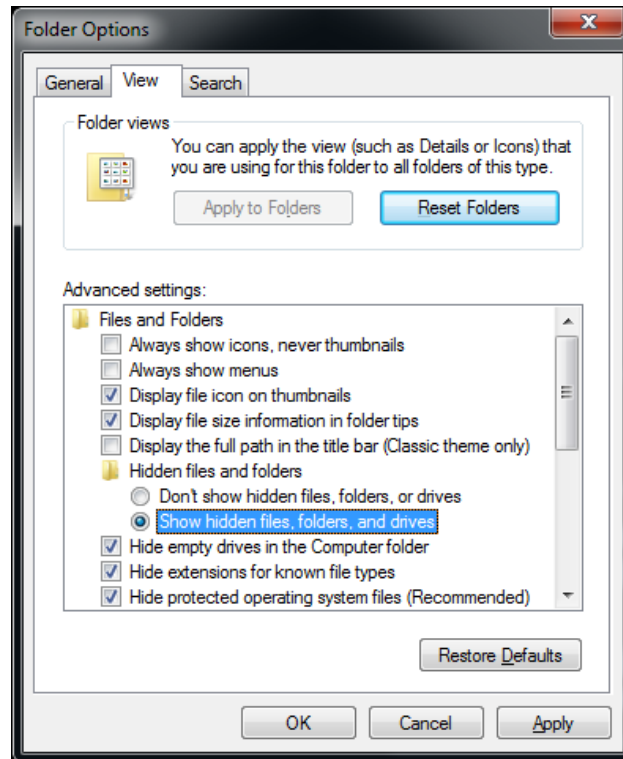

Right click on the desktop, click New, then click Folder. This will place and empty folder on the desktop. Give the folder a name. In this example the folder was named Erik Programs.

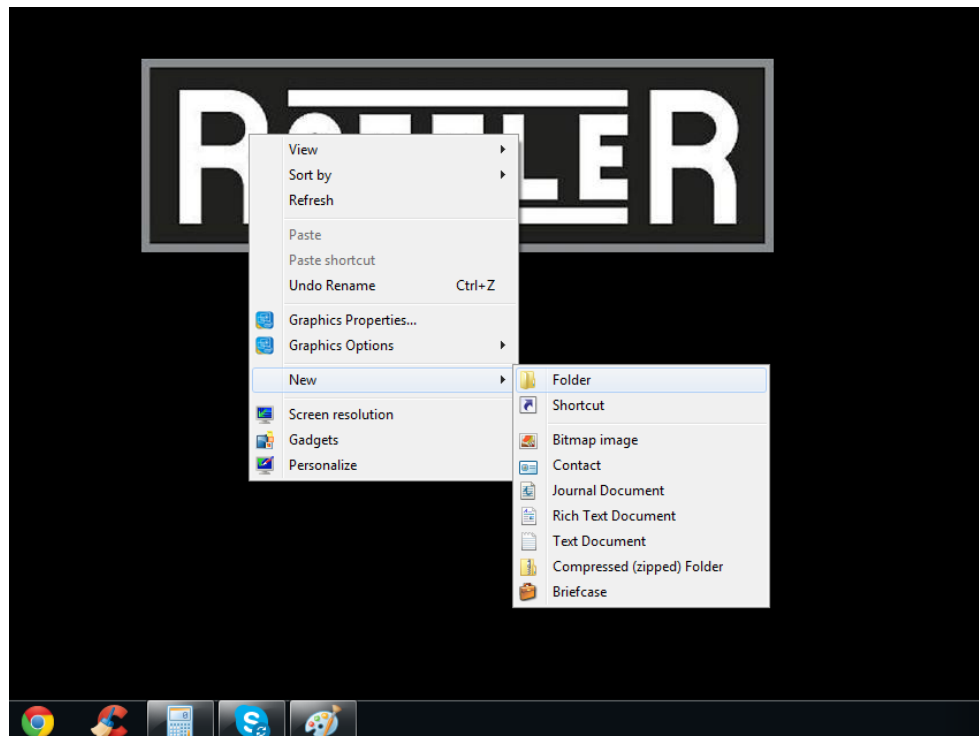

Open Windows Explorer and click on Local Disk (C), then Direct Path.

Once the Direct Path folder is open, locate all the PartSolution files and move them into the folder you created.

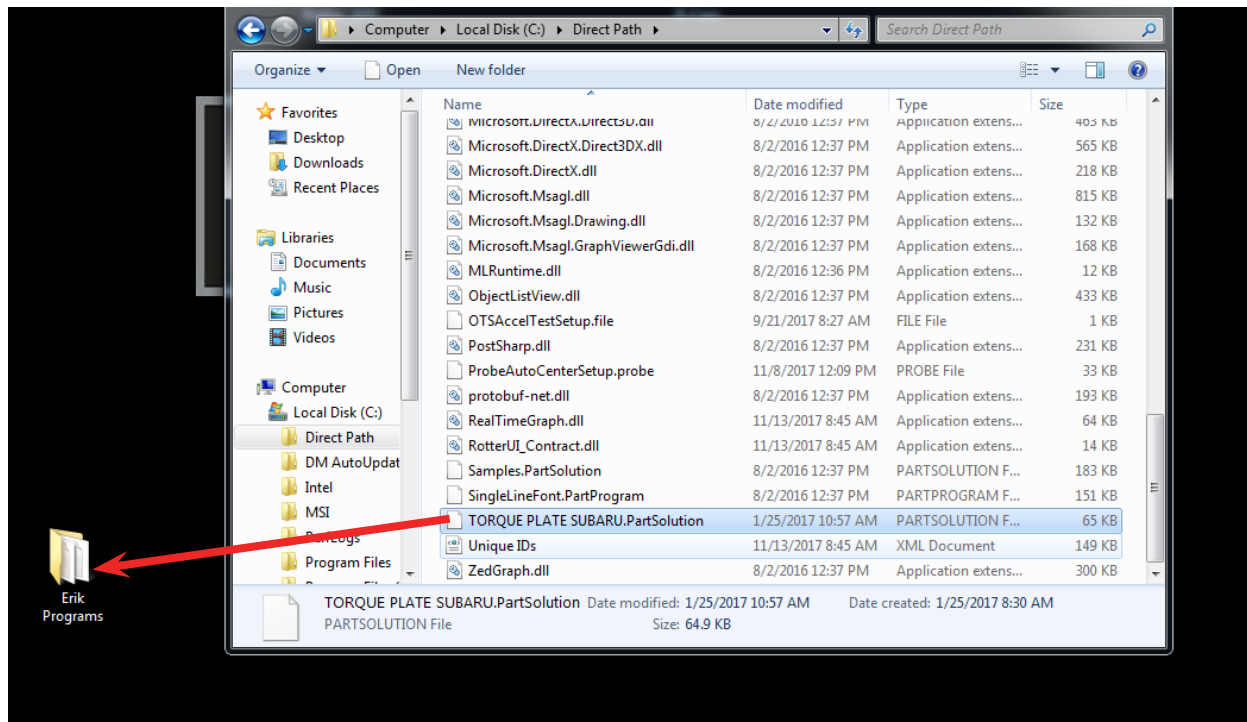

Once you have completed moving all the files, open the folder to confirm that the files are in the folder.

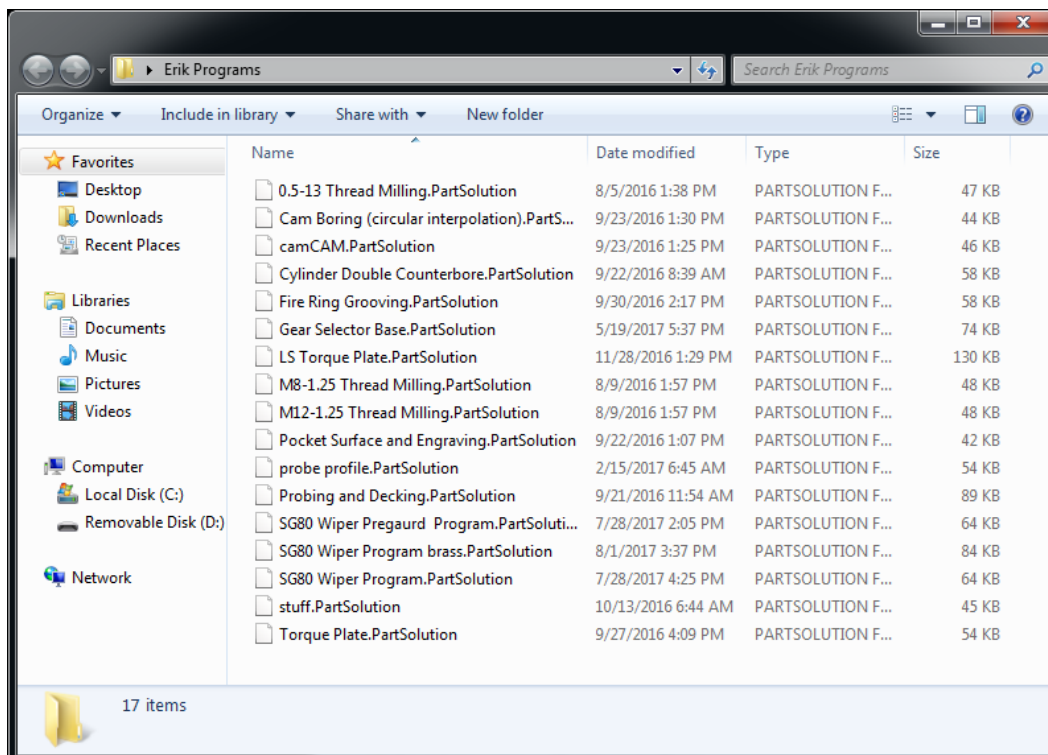

Take a flash drive and plug it into an open usb port located on the side of the monitor housing.

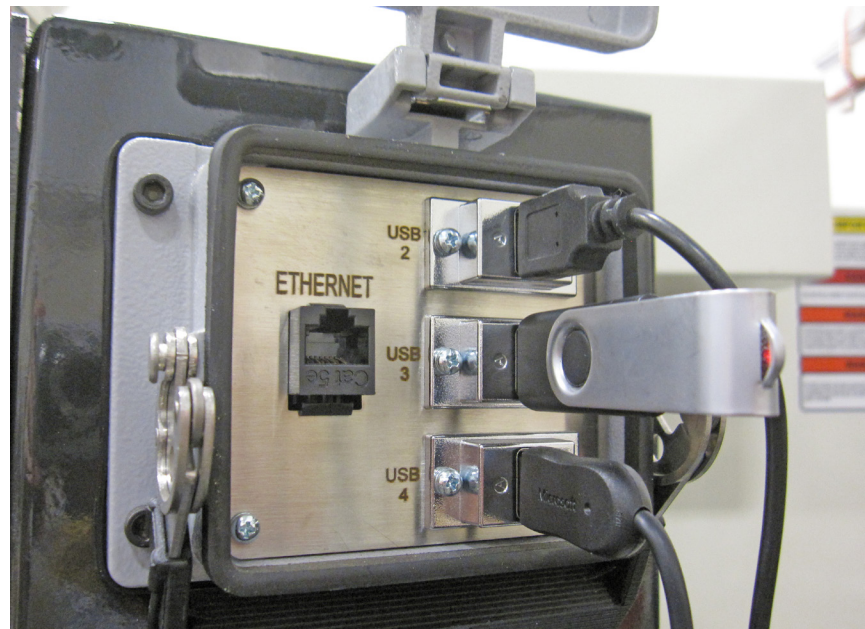

When the AutoPlay window appears, click on Open folder to view files.

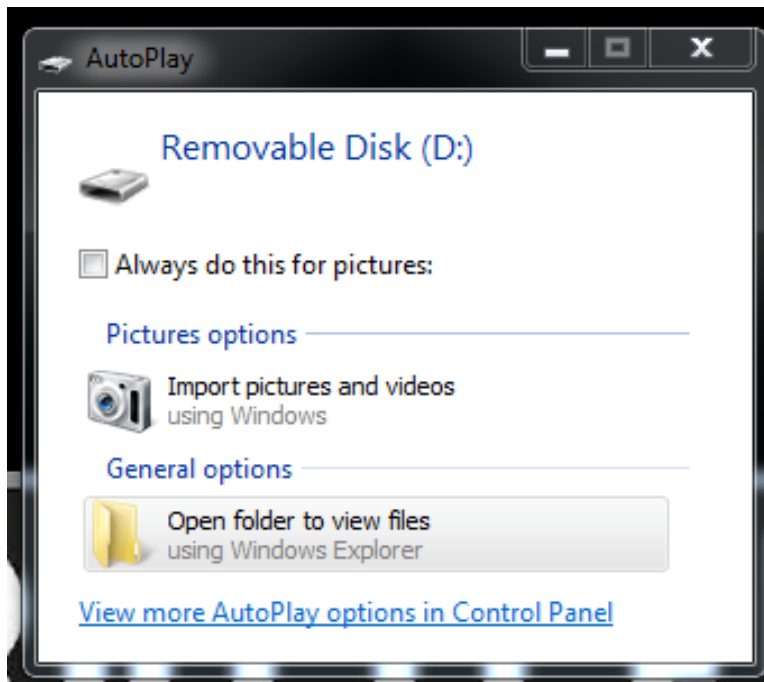

Once the window for the flash drive opens, click and drag the folder you created into the flash drive folder.

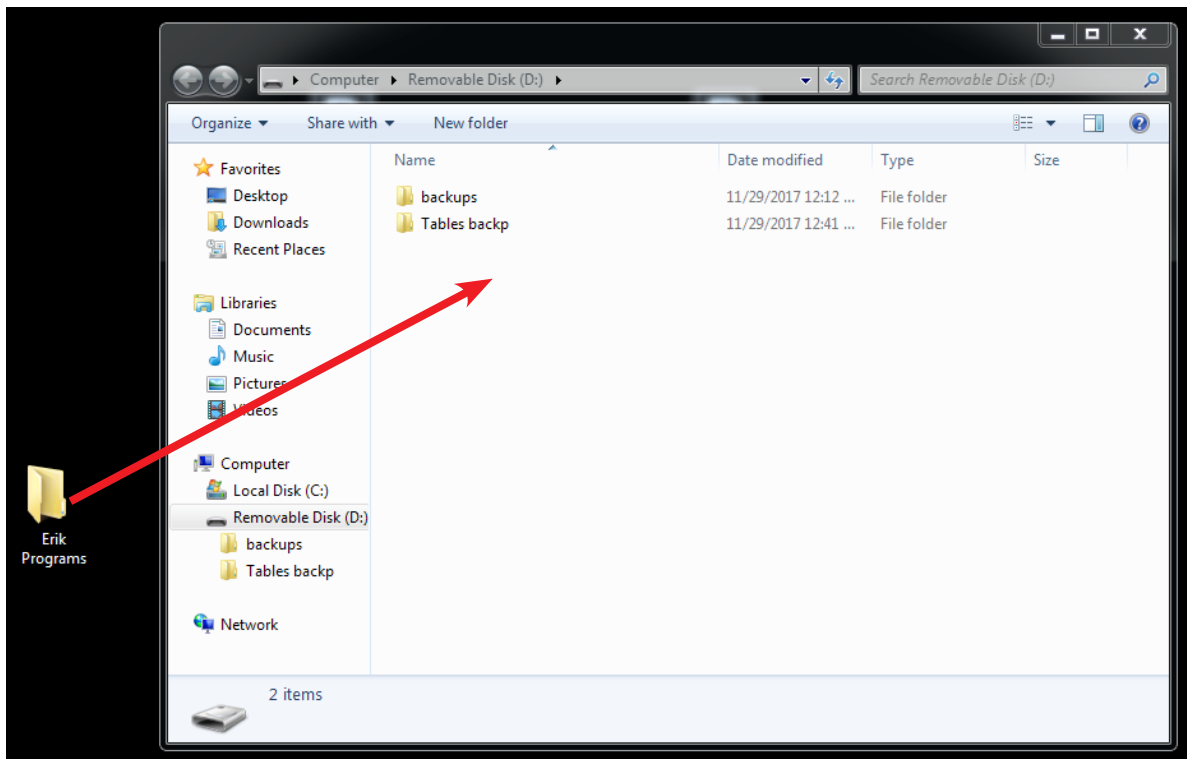

A copy of the folder will appear in the flash drive directory. Backup is now complete. Close the window and remove the flash drive.

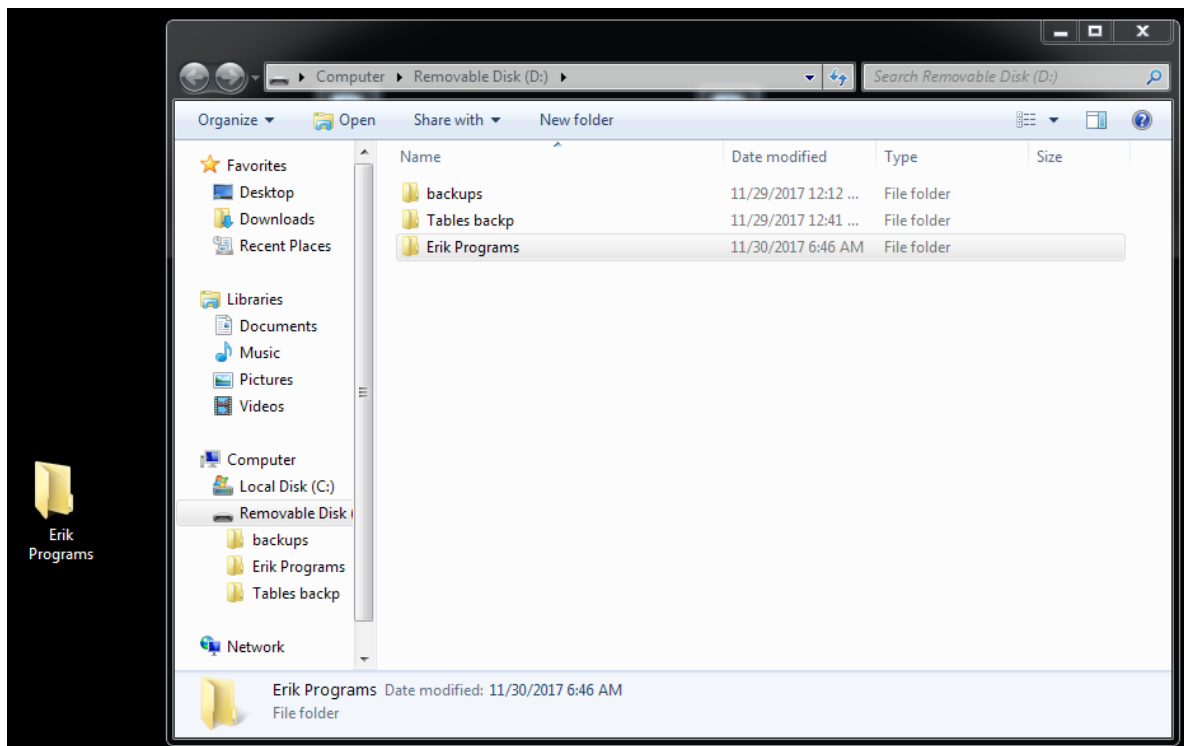

To restore RCam programs plug the flash drive with the backups into the usb hub on the side of the monitor housing.

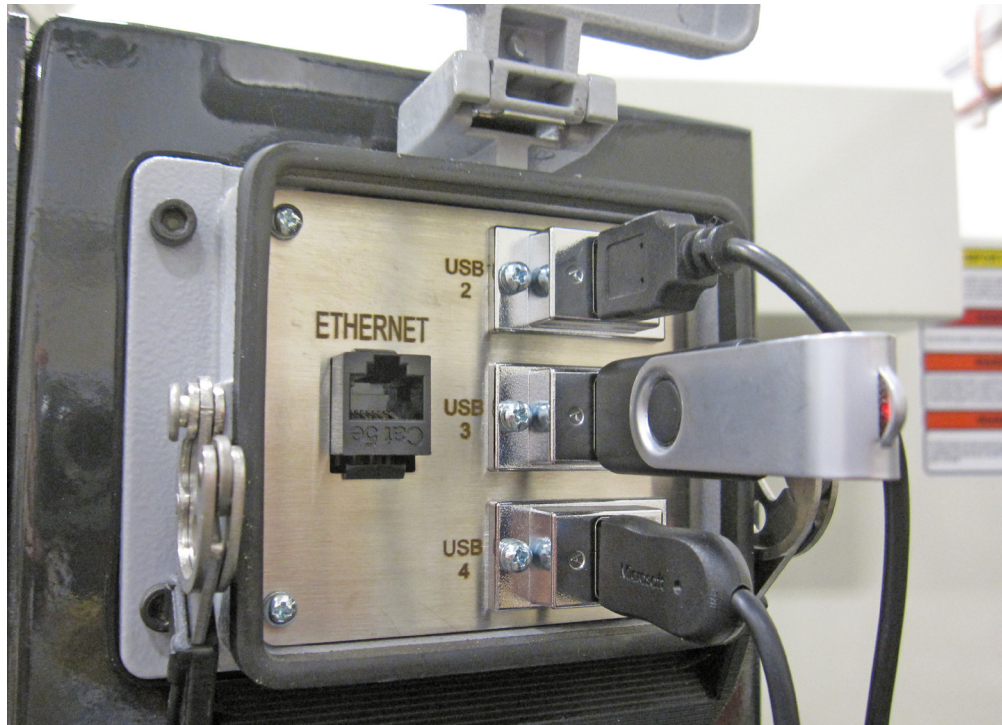

When the AutoPlay window appears, click on Open folder to view files.

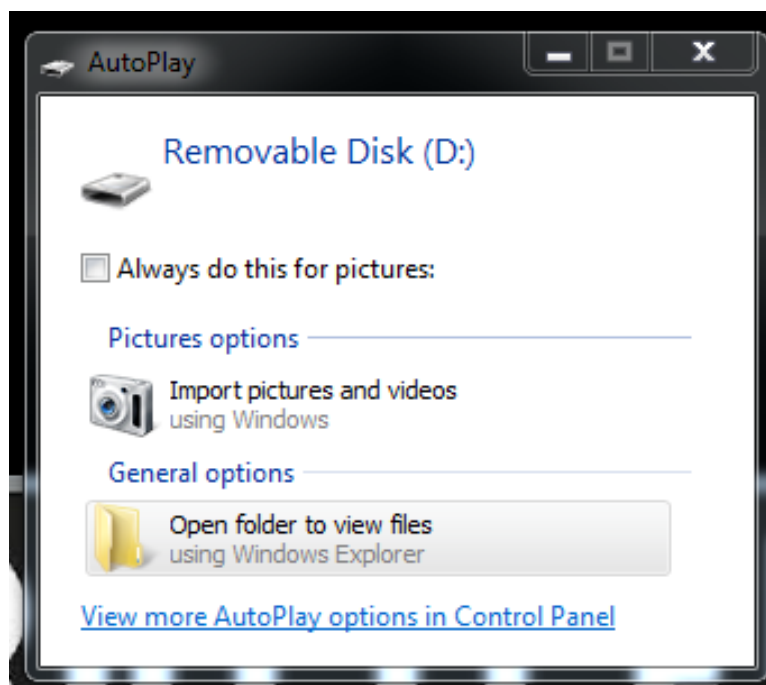

Once the window for the flash drive opens, click and drag the backup folder to the desktop.

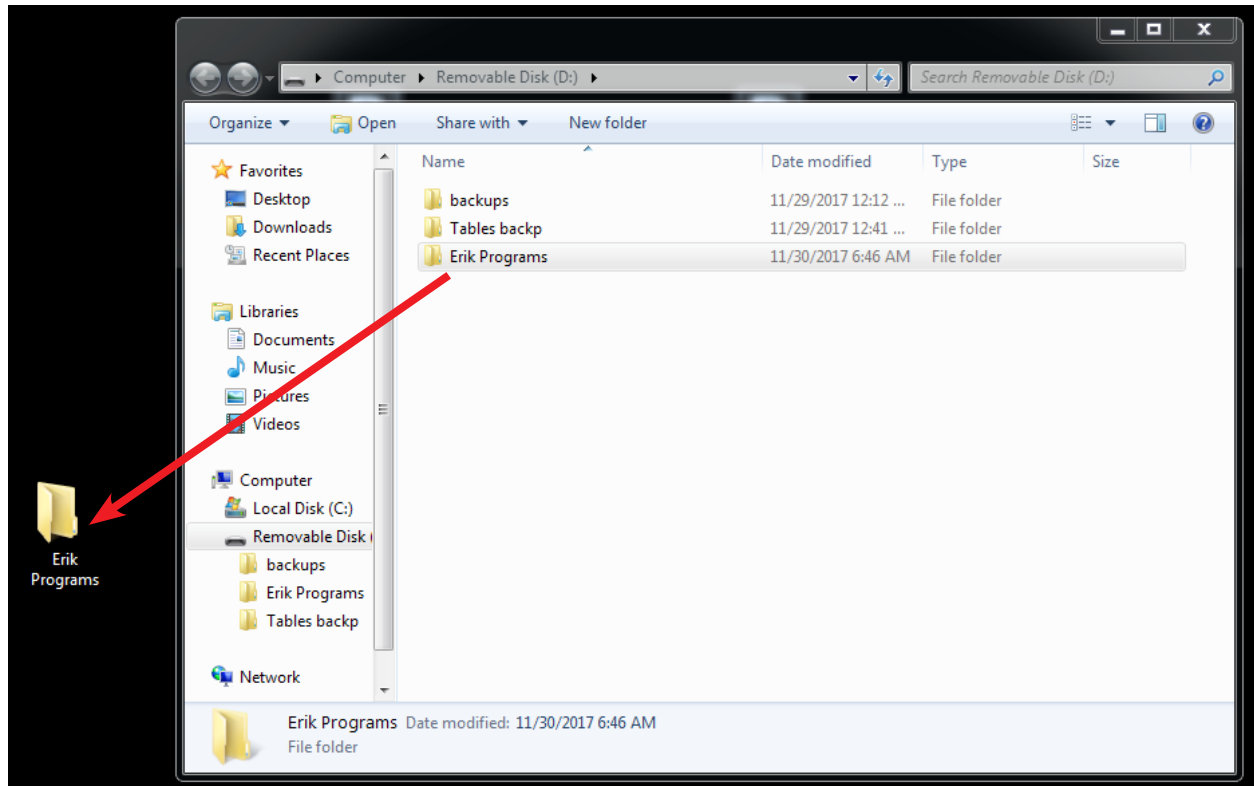

If you still have a program folder on the desktop you will get the following message. Click Yes.

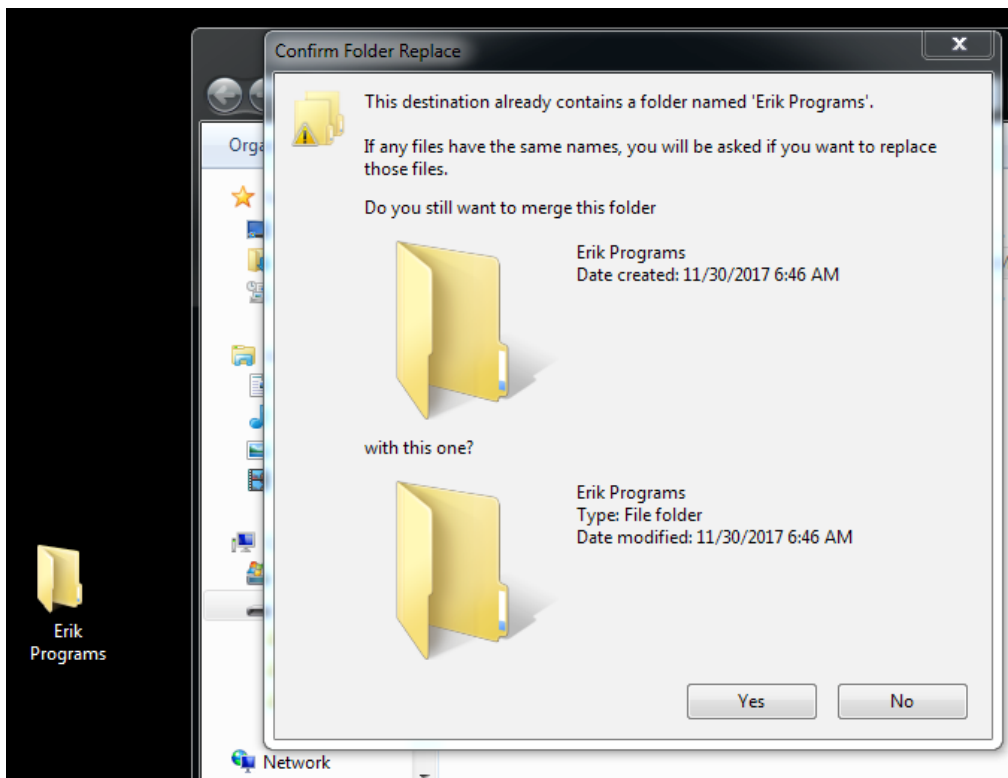

If the Copy File window appears, click on the Copy and Replace option.

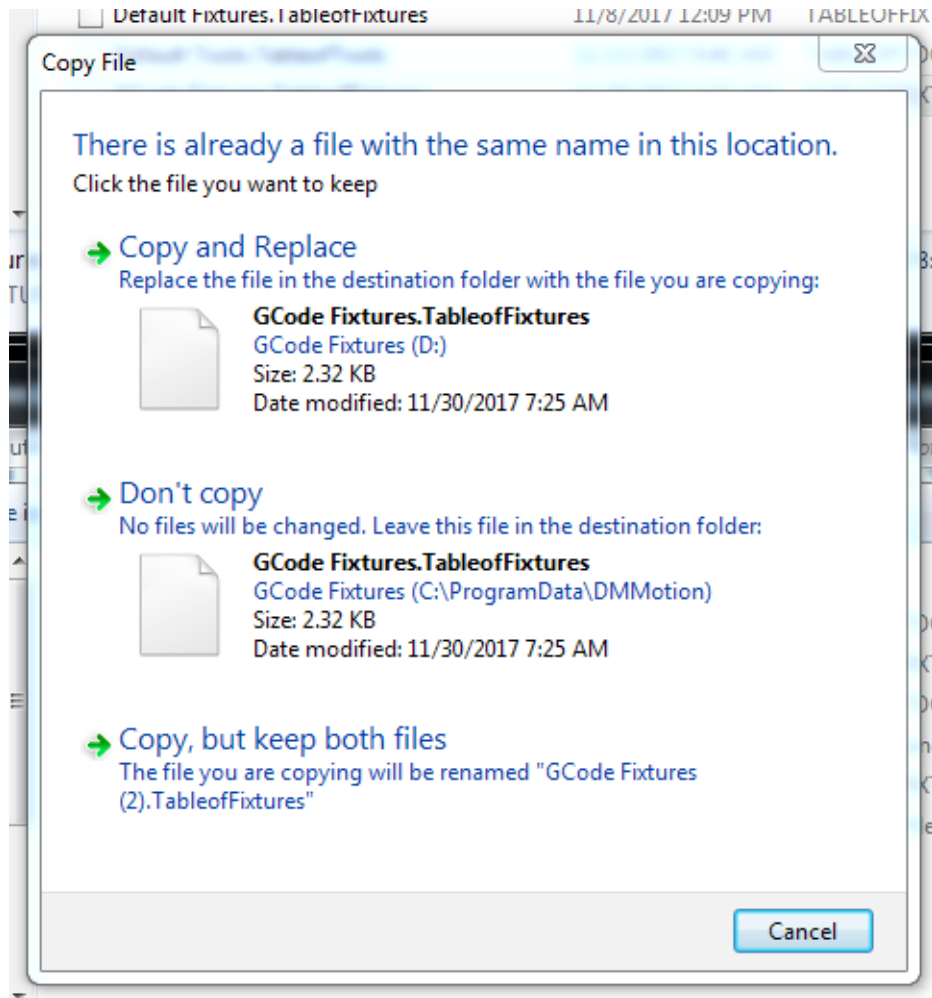

After all the programs have been restored close the window and remove the flash drive.

Backing Up and Restoring RCam Tables

Click on the Windows icon and type “hidden” in the search box.

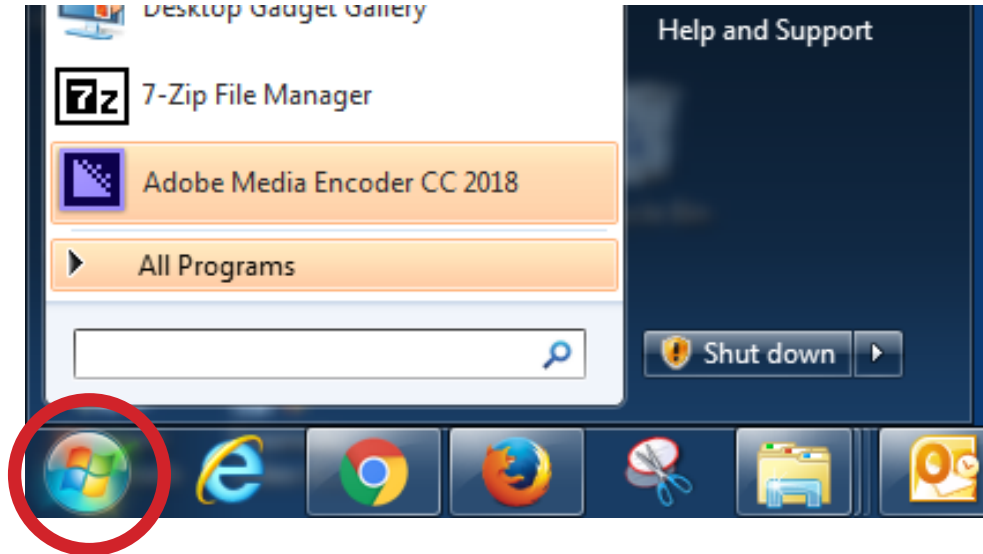

When the search results appear, click on the Show hidden files and folders option.

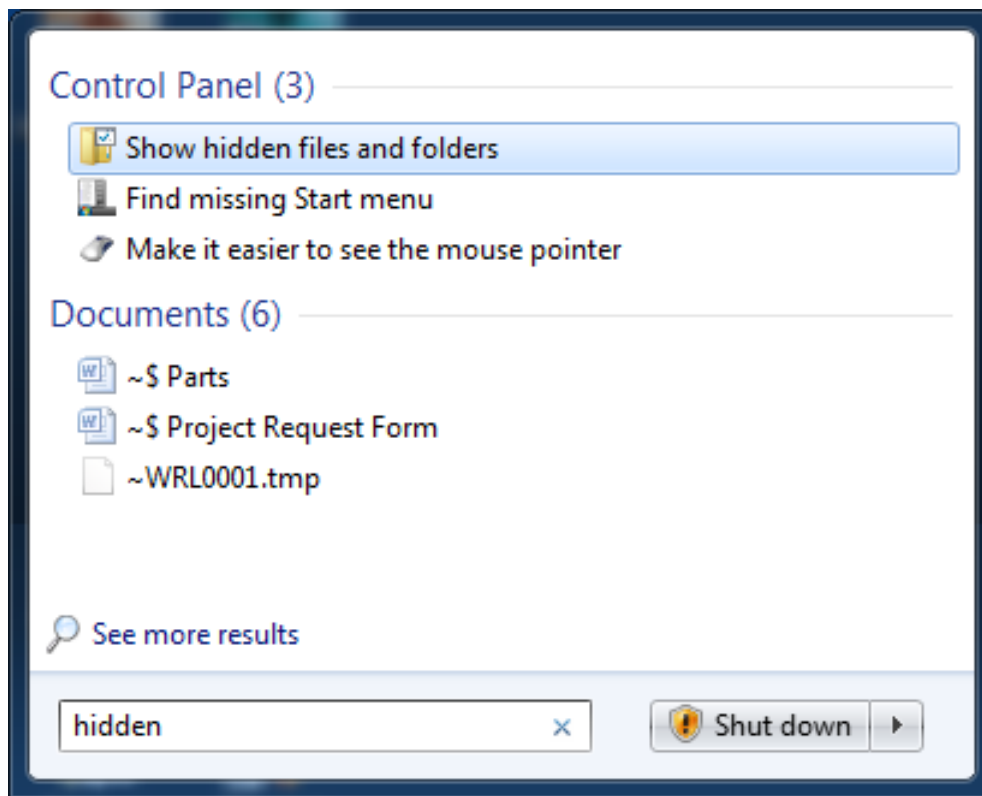

The Folders Options box will appear. Click to on the Show hidden files, folders, and drives to activate the option. Click on Apply, then OK.

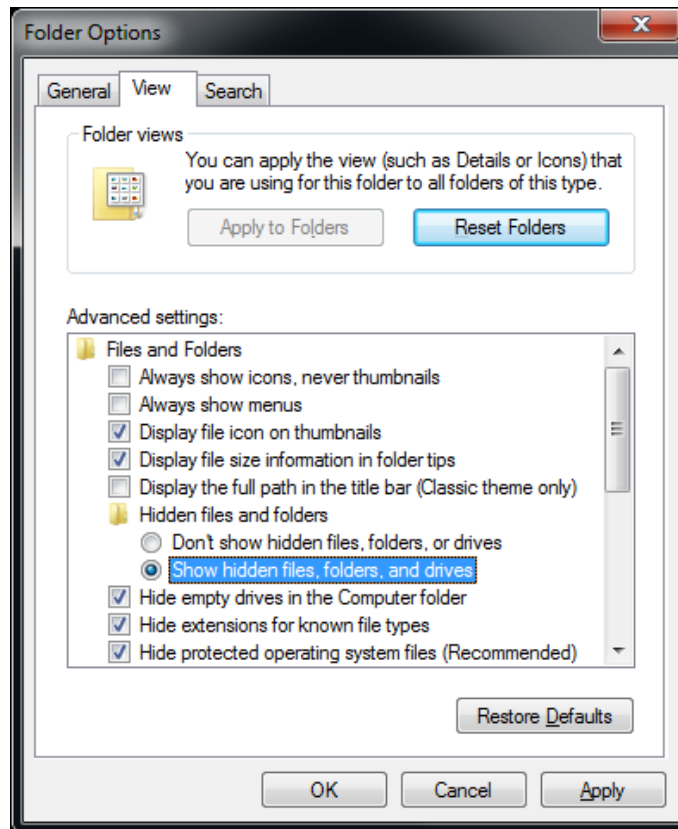

Take a flash drive and plug it into an open usb port located on the side of the monitor housing.

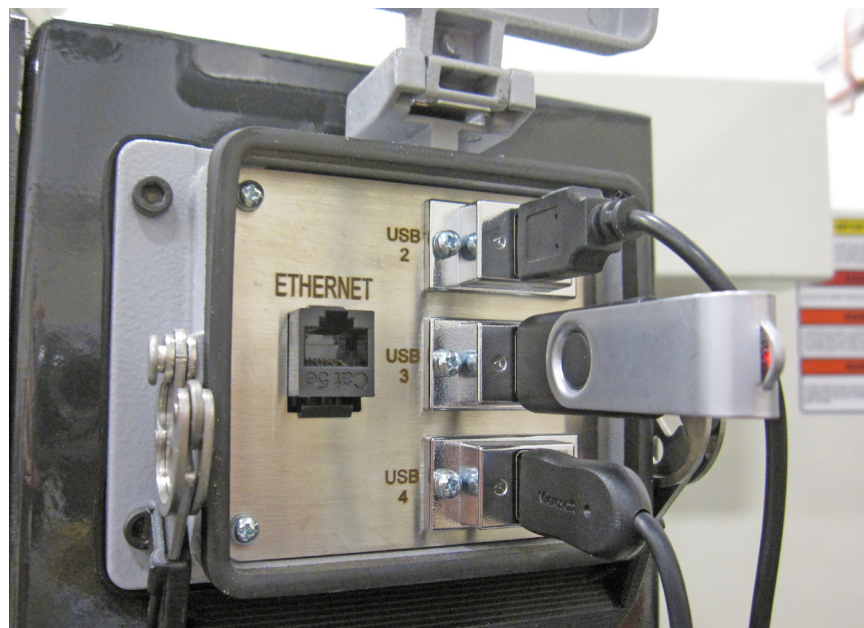

When the AutoPlay window appears, click on Open folder to view files.

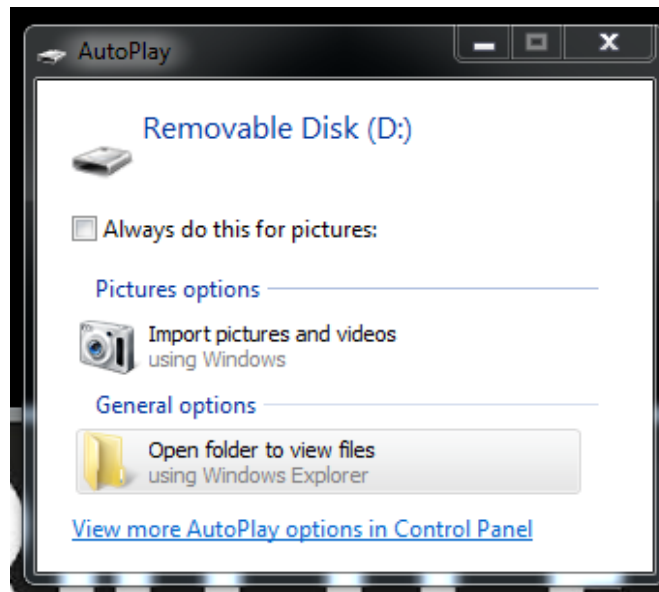

When the explorer window opens, click on Local Disk (C:), then ProgramData folder to open it.

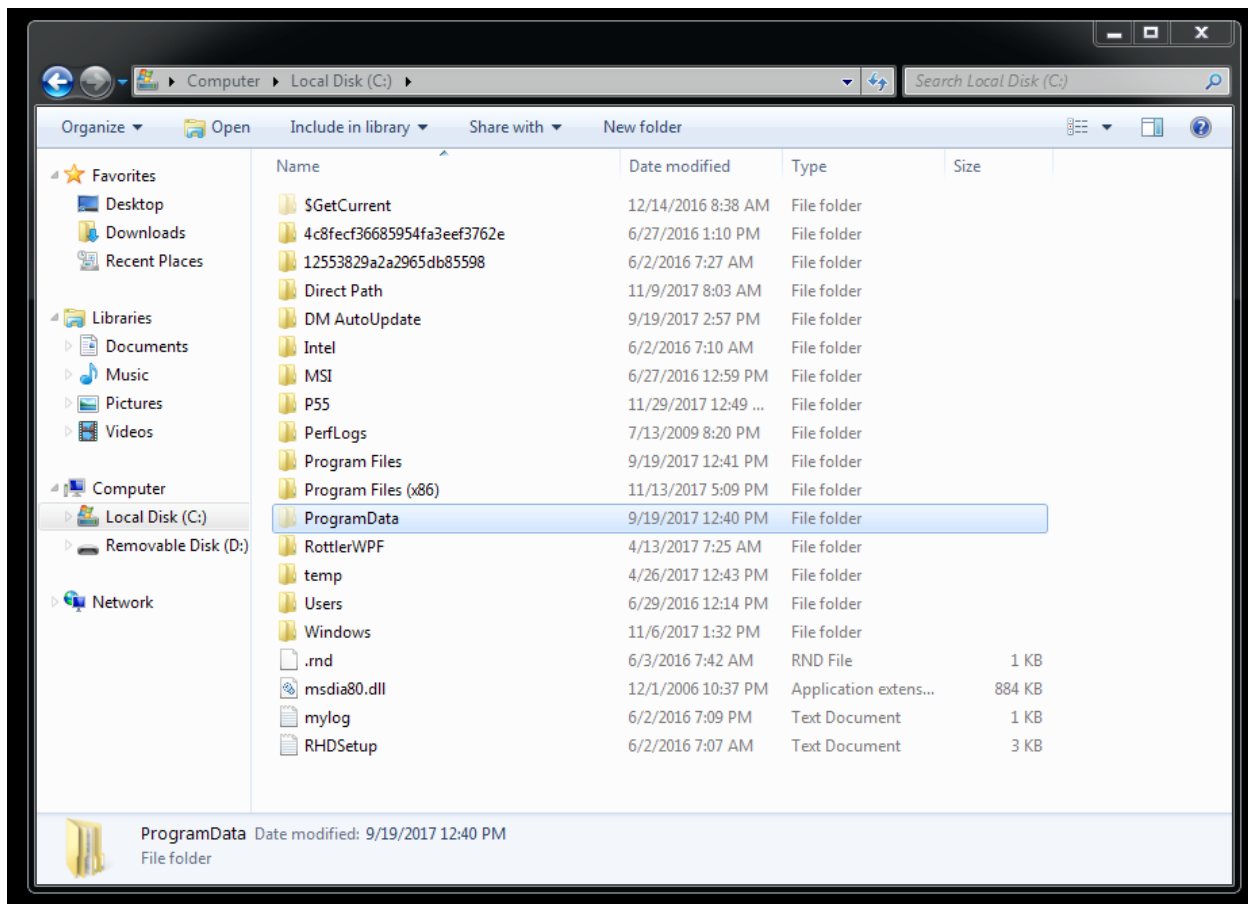

Click on the DMMotion folder to open it.

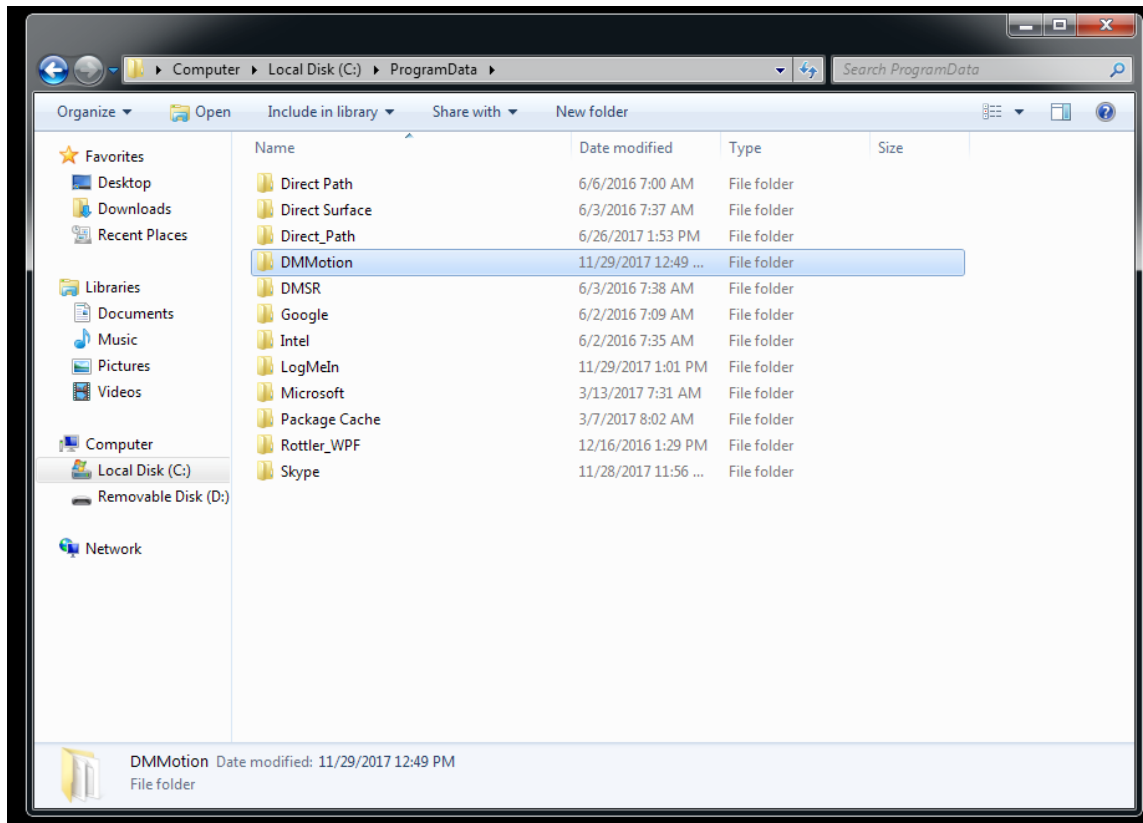

Once the folder is open find all the Table files and drag them to the flash drive.

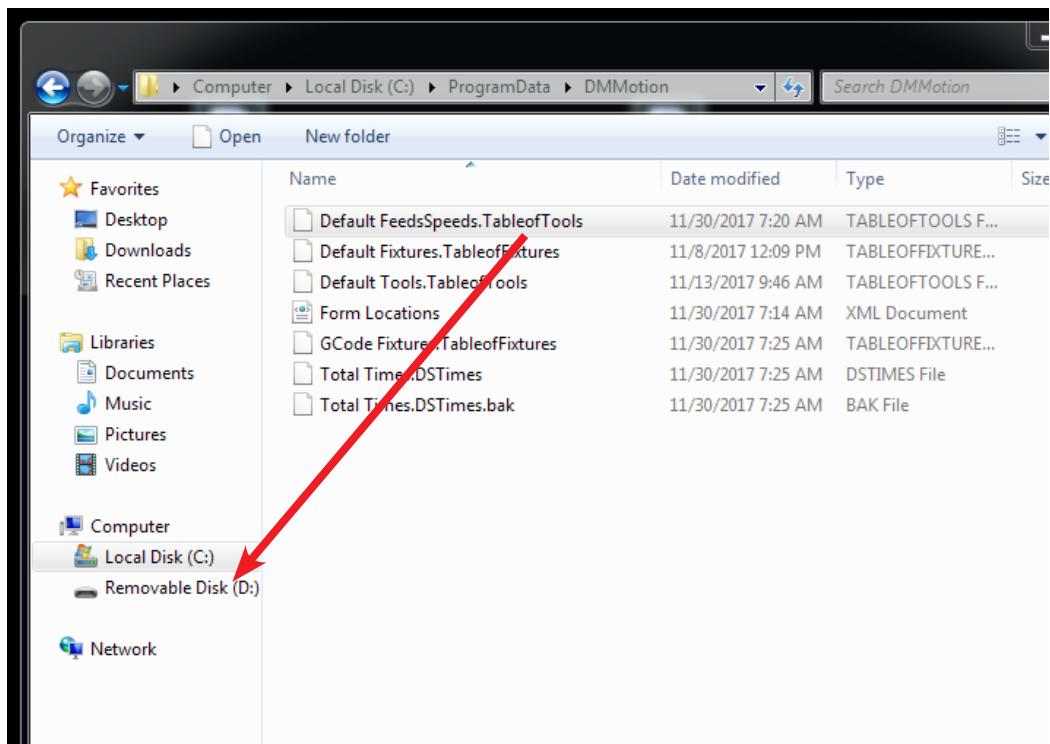

Open the flash drive folder to confirm that all the Tables files were copied.

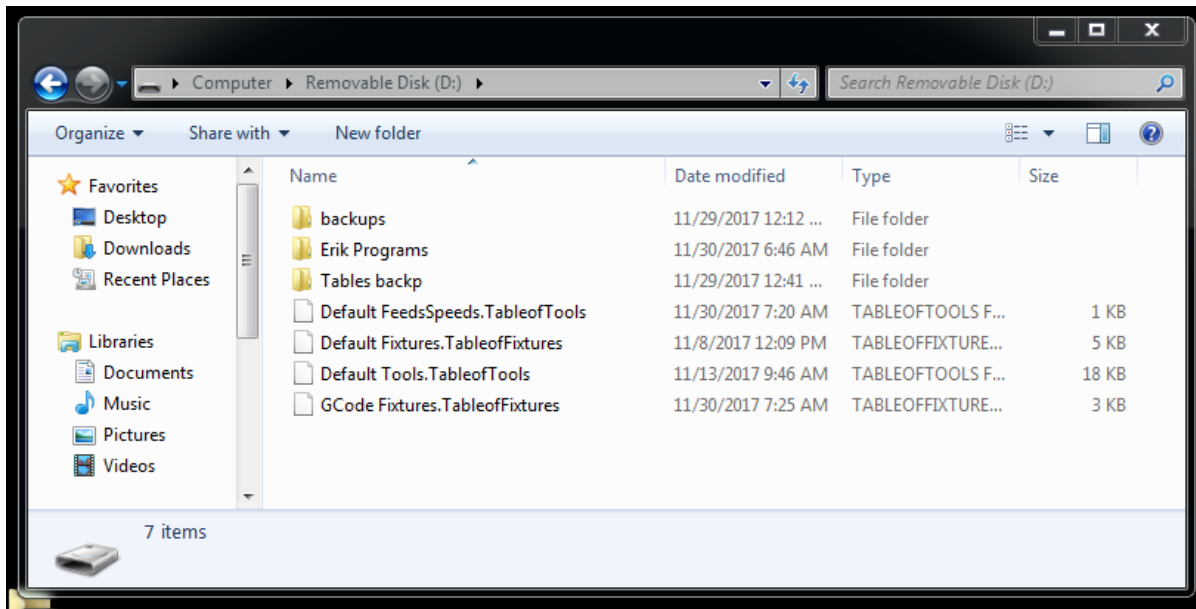

Close the window and remove the flash drive. Backup is now completed.

To restore RCam programs plug the flash drive with the backups into the usb hub on the side of the monitor housing.

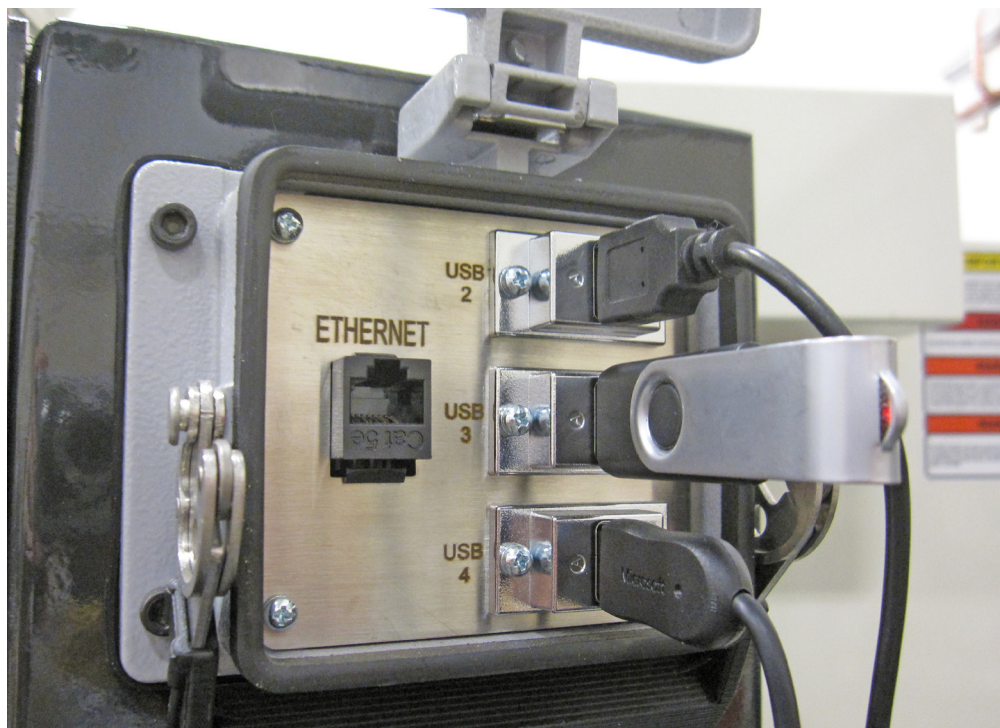

When the AutoPlay window appears, click on Open folder to view files.

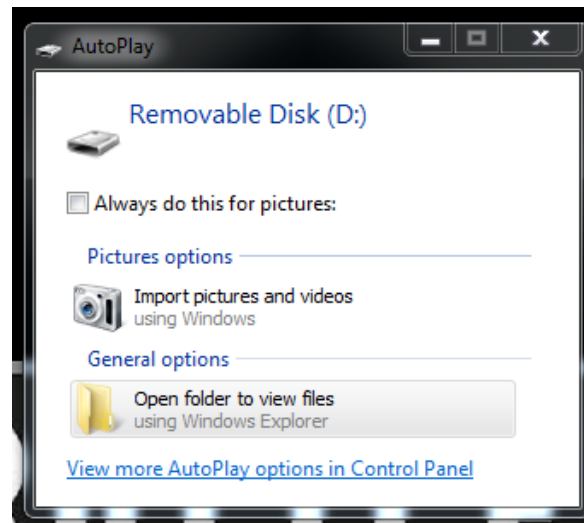

Open a second file explorer window and navigate to the DMMotion folder. Arrange both windows as shown.

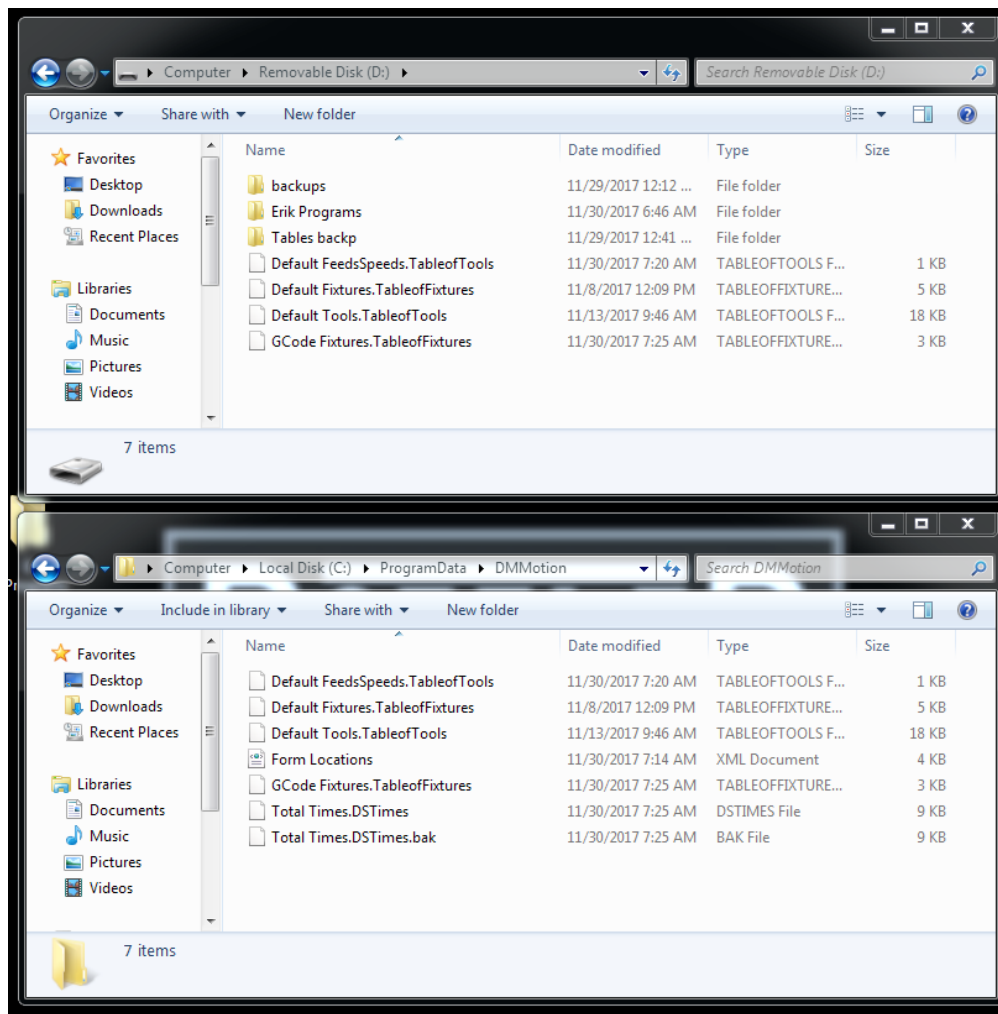

Drag all the Table files from the flash drive to the DMMotion folder.

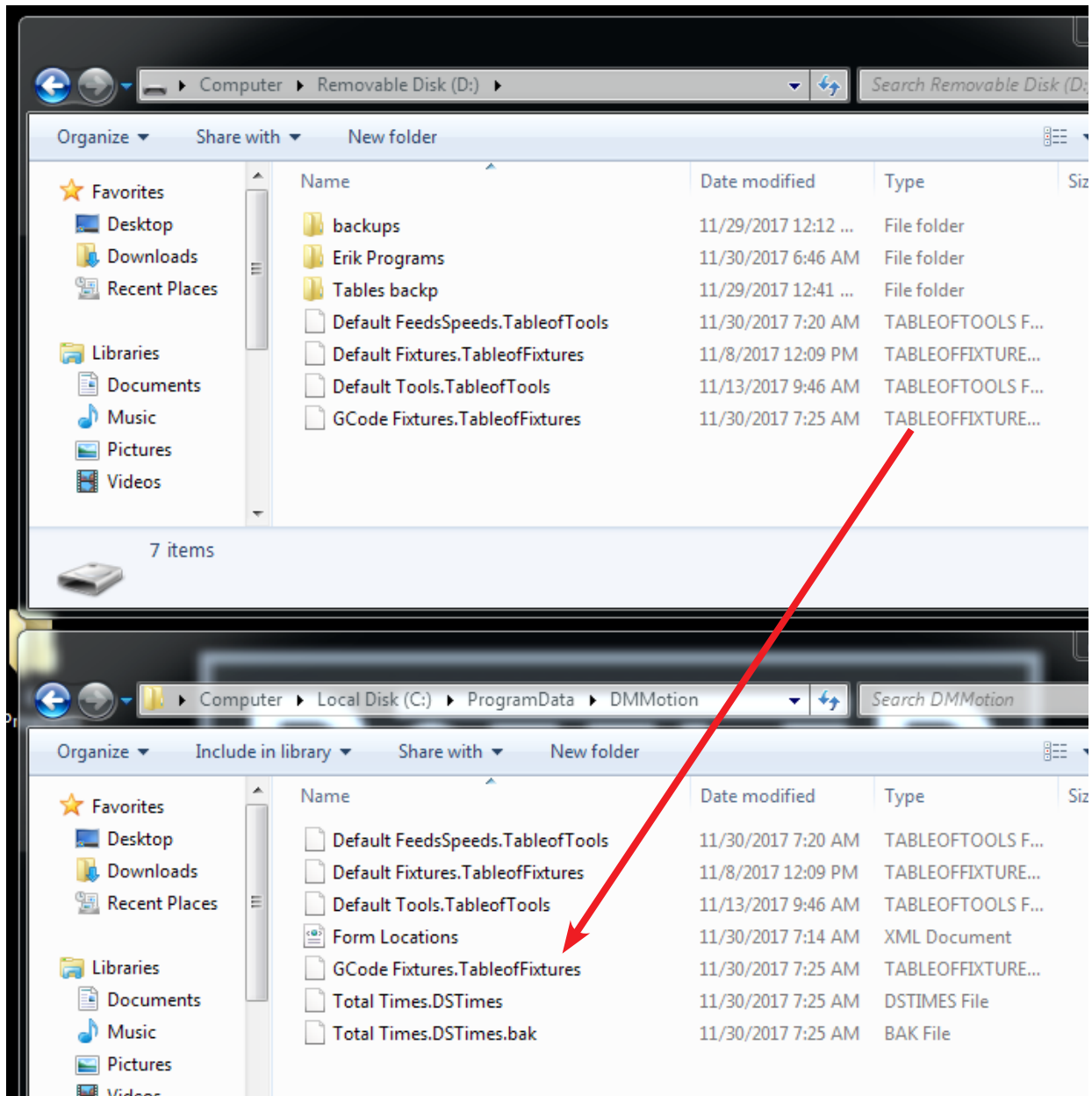

If the Copy File window appears, click on the Copy and Replace option.

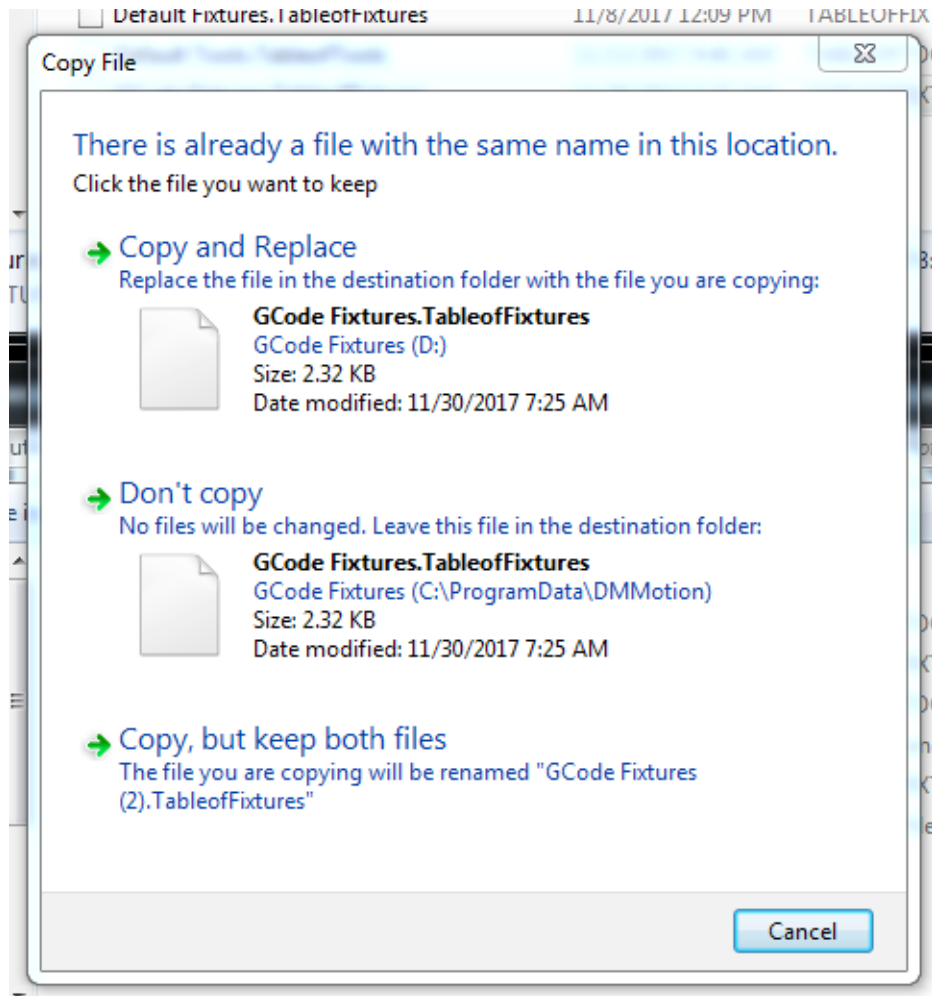

After all the programs have been restored close the window and remove the flash drive.

Using 3rd Party Tooling in Rottler Machines with CAT 40 Tooling.

When it is not convenient for the customer to order CAT 40 tooling from the factory or if the customer needs tooling that we don't stock, they may purchase tooling from 3rd party vendors such as MSC Metalworking.

Rottler uses a Parlec - A Style, CAT40 Taper, 5/8-11 Thread, 45 Degree Angle Radius, Standard Retention Knob with the following specifications: 1.68 Inch Overall Length, 0.281 Inch Coolant Hole Diameter, 0.74 Inch Knob Diameter, 0.12 Inch Flange Thickness, 0.64 Inch Knob to Flange Length, 0.635 Inch Pilot Diameter, Through Coolant.



The metric equivalent is a Parlec - A Style, BT40 Taper, M16 x 2 Thread, 45° Angle Radius, Standard Retention Knob 1.65 Inch Overall Length, 0.281 Inch Coolant Hole Diameter, 0.74 Inch Knob Diameter, 0.12 Inch Flange Thickness, 0.64 Inch Knob to Flange Length, 0.669 Inch Pilot Diameter, Through Coolant.



MAINTENANCE

Contents

Maintenance	6-1
Quick Reference Lubrication Chart: F69ATC	6-1
Quick Reference Preventative Maintenance: F69ATC	6-2
Lubrication	6-5
Automatic Lubrication System	6-5
Power Draw Bar Lubrication	6-6
Probe “On-Center” Adjustment	6-7
Leveling and Alignment	6-11
Leveling the Machine.....	6-11
Alignment	6-12
Middle Leveling Bolts	6-15
Sweeping the Spindle.....	6-17
Vertical Gib Adjustment.....	6-19
Performance Fixture Line-Up.....	6-20
Performance Fixture Line-Up (Cam End Tunnel Boring).....	6-21
To Copy Block Info From Your Machine	6-22
To Install Block Info Onto Your Machine	6-22
Replacing the Motherboard Battery	6-23
Digital Micrometer setting instructions	6-26
Tool Changer Maintenance	6-31

Maintenance

Quick Reference Lubrication Chart: F69ATC

Refer to the maintenance section in the manual for lubrication location points and instruction.

Assembly	Frequency Hours	Lube Operation	Recommended Lubricant	Date Serviced
Way Oil Level	40	Fill as needed	Conoco Brand 76 Way Oil HD 68 or ISO VG 68 equivalent	
Lube ATC arm	160	Grease per instruction procedure	76 Unoba EP2 or equivalent NLGI 2 Multi-Purpose Grease	
Drawbar oil level	160	Fill as needed	General Purpose air tool oil	

Quick Reference Preventative Maintenance: F69ATC

Refer to the procedures in the maintenance section of the manual to make or check these adjustments. Not all of the items listed in the table below have adjustment. The information should be recorded and the amount of wear tracked so the part can be replaced before down time on the machine occurs.

Procedure	Frequency Hours	Date Serviced/Comments
Check Way Oil Functionality	160	
Visually Inspect Way Covers	160	
Replace Coolant	480	
Check Air Pressure Regulators	480	
Check Backlash	960	
Check Gibbs	960	
Check Home Presets	960	
Check for Loose Bolts	960	
Check Machine Geometry	960	
Check Incoming Voltage	960	
Flush Cooling System	1920	

Removable copy

Quick Reference Lubrication Chart: F69ATC

Refer to the maintenance section in the manual for lubrication location points and instruction.

Assembly	Frequency Hours	Lube Operation	Recommended Lubricant	Date Serviced
Way Oil Level	40	Fill as needed	Conoco Brand 76 Way Oil HD 68 or ISO VG 68 equivalent	
Lube ATC arm	160	Grease per instruction procedure	76 Unoba EP2 or equivalent NLGI 2 Multi-Purpose Grease	
Drawbar oil level	160	Fill as needed	General Purpose air tool oil	

Removable copy

Quick Reference Preventative Maintenance: F69ATC

Refer to the procedures in the maintenance section of the manual to make or check these adjustments. Not all of the items listed in the table below have adjustment. The information should be recorded and the amount of wear tracked so the part can be replaced before down time on the machine occurs.

Procedure	Frequency Hours	Date Serviced/Comments
Check Way Oil Functionality	160	
Visually Inspect Way Covers	160	
Replace Coolant	480	
Check Air Pressure Regulators	480	
Check Backlash	960	
Check Gibbs	960	
Check Home Presets	960	
Check for Loose Bolts	960	
Check Machine Geometry	960	
Check Incoming Voltage	960	
Flush Cooling System	1920	

Lubrication

Automatic Lubrication System

The automatic lubrication system includes metering valves for proportional distribution and includes an alarm for low fluid level warning. Still, please check fluid level before operation. Add **ISO VG 68 Way Oil** as needed in reservoir at rear of machine.



Power Draw Bar Lubrication

The Power Draw Bar assembly has a gravity feed oiling system. Use machine tool oil in this reservoir. The reservoir is located on the side of the Draw Bar Assembly cylinder. There is a window on the side of the headstock cover to observe the oil level in the reservoir. Add ISO VG 22 Air Tool Oil as needed. Refer to the following illustration for filling location.







Probe “On-Center” Adjustment

This covers setup and calibration of the probe, so it will accurately position your machine.

- Verify that the four adjusting screws and two locking screws are installed in the probe tool holder.
- Assemble probe on either CAT 40 Shank or Rottler Taper
- With the machine breaker that supplies power to the probe receiver turned off;
- Install batteries in the probe WITH stylus deflected.

Probe LED check will run.

- Release stylus after battery check this will put you in edit mode.
- First will be Switch off method, you want this at **purple, purple, yellow** (Radio On). If it is not, deflect and release stylus quickly to change the mode.
- Hold the stylus deflected until the colors change to move to the next setting.
- You should be at Switch Off method; it should be **red, red, yellow** (134 seconds). If it is not, deflect and release stylus quickly to change the mode.
- Hold the stylus deflected until the colors change to move to the next setting.
- You should be at Enhanced trigger filter; it should be **green, green, green** (on). If it is not, deflect and release stylus quickly to change the mode.
- Hold the stylus deflected until the colors change again to move to the next setting.
- You should be at Acquisition mode, **light blue, light blue, light blue**.
- Turn on machine and quickly deflect and release the stylus. This must be done within 10 seconds of turning on the power breaker to the probe. If you are watching the RMI-Q (located ON the machine) you will see the right light turn **red, yellow, red, yellow, red, yellow** is shows the partnership has been acquired.
- Go into the software and do a probe auto center and hit start probe to verify that it works correctly.

Key to the symbols	
	LED short flash
	LED long flash
	Deflect the stylus for less than 4 seconds to move to the next menu option.
	Deflect the stylus for more than 4 seconds to move to the next menu.
	To exit, leave the stylus untouched for more than 20 seconds.

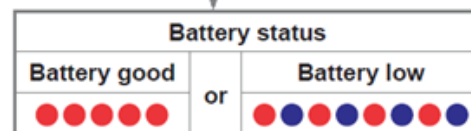
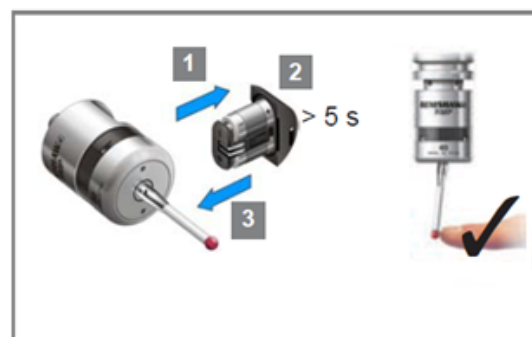

Switch on method, next page

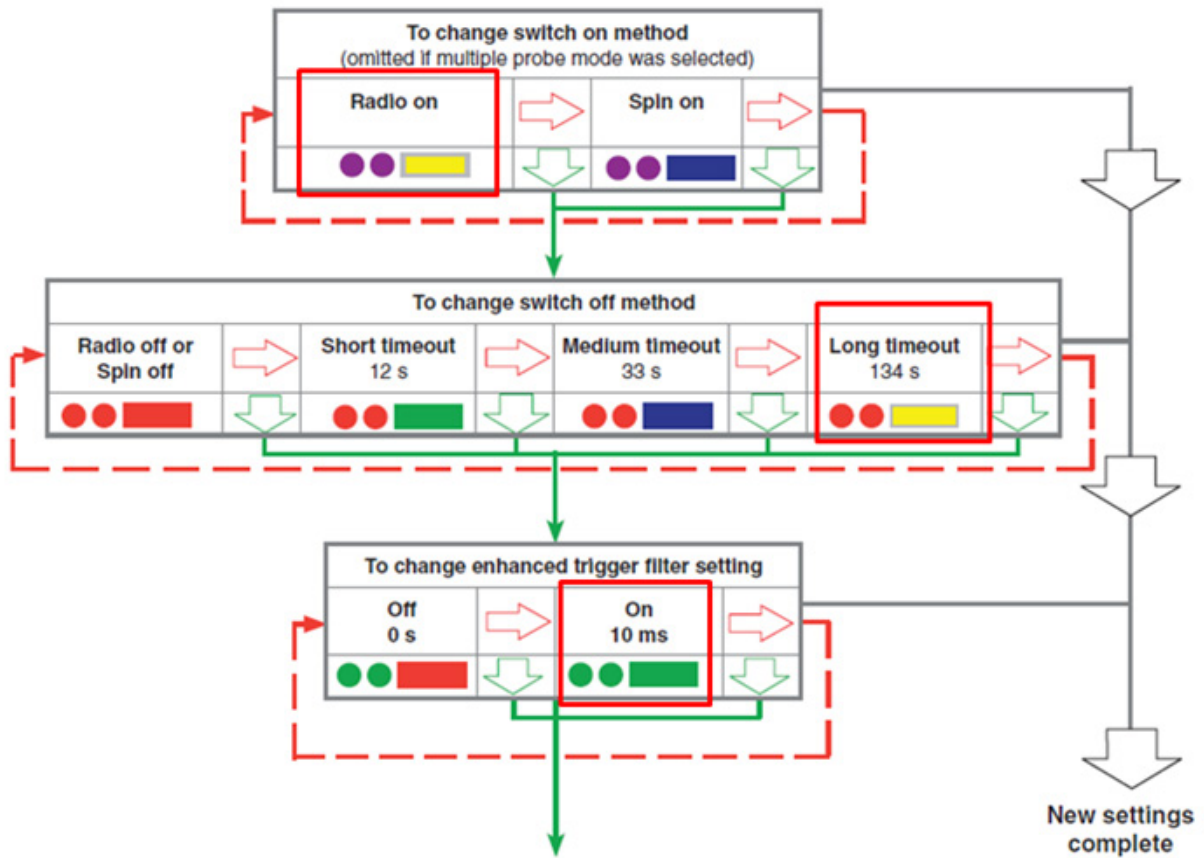

Changing the probe settings (continued)

Note: After the RMI has been acquired, the RMP40 will only show Acquisition mode off.

See RMP40 - RMI partnership.

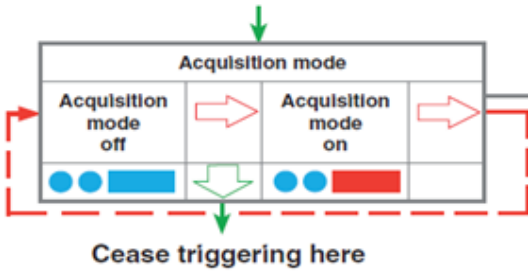

If the Probe does not turn off after 137 seconds you will need to make sure that the RMI-Q switches are shown in the following positions:

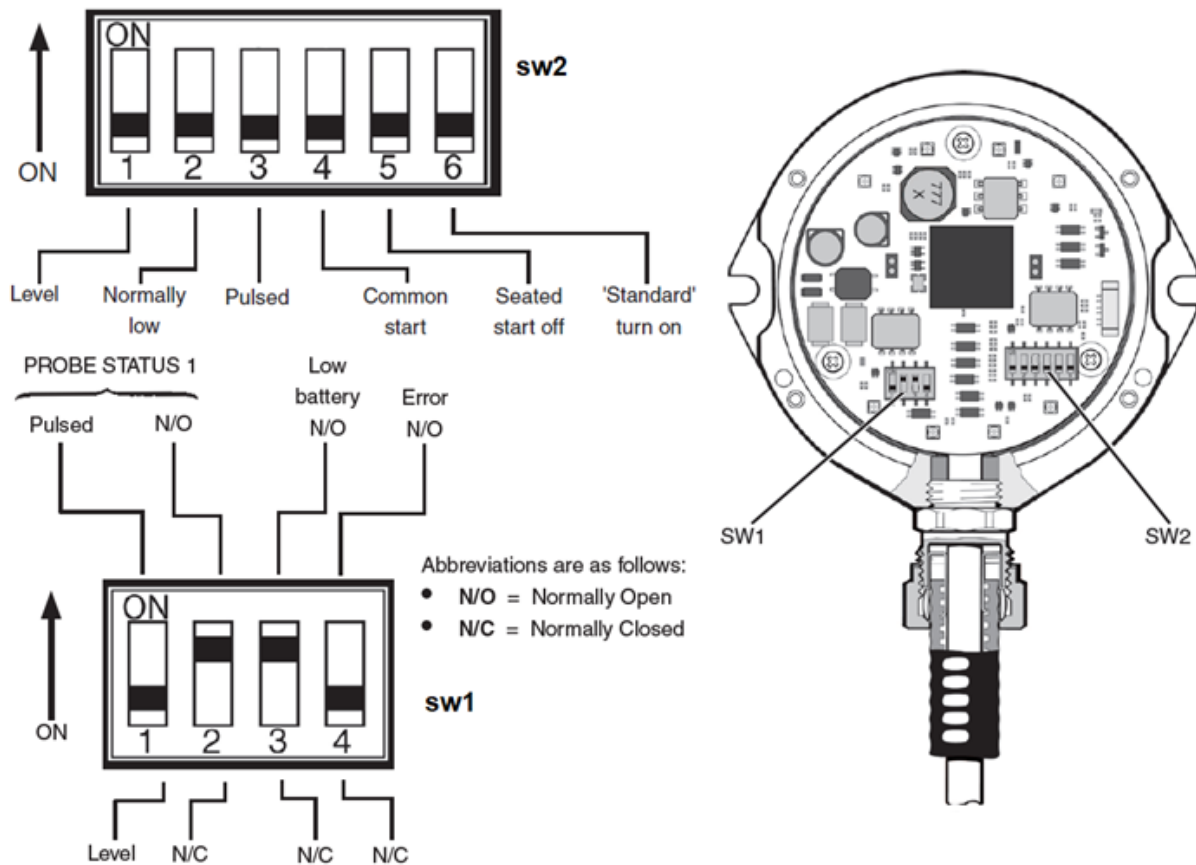

During normal use, the difference between the touch position and the reported position does not change, but it is important that the probe is calibrated in the following circumstances:

- when a probe system is to be used for the first time;
- when a new stylus is fitted to the probe;
- when it is suspected that the stylus has become distorted or that the probe has crashed;
- at regular intervals to compensate for mechanical changes of your machine tool;
- if repeatability of relocation of the probe shank is poor. In this case, the probe may need to be recalibrated each time it is selected.

It is good practice to set the tip of the stylus on center, because this reduces the effect of any variation in spindle and tool orientation. A small amount of run-out is acceptable, and can be compensated for as part of the normal calibration process.

- calibrating either in a bored hole of know size, a ring gauge, or on a datum sphere.

Mounting the probe on a shank

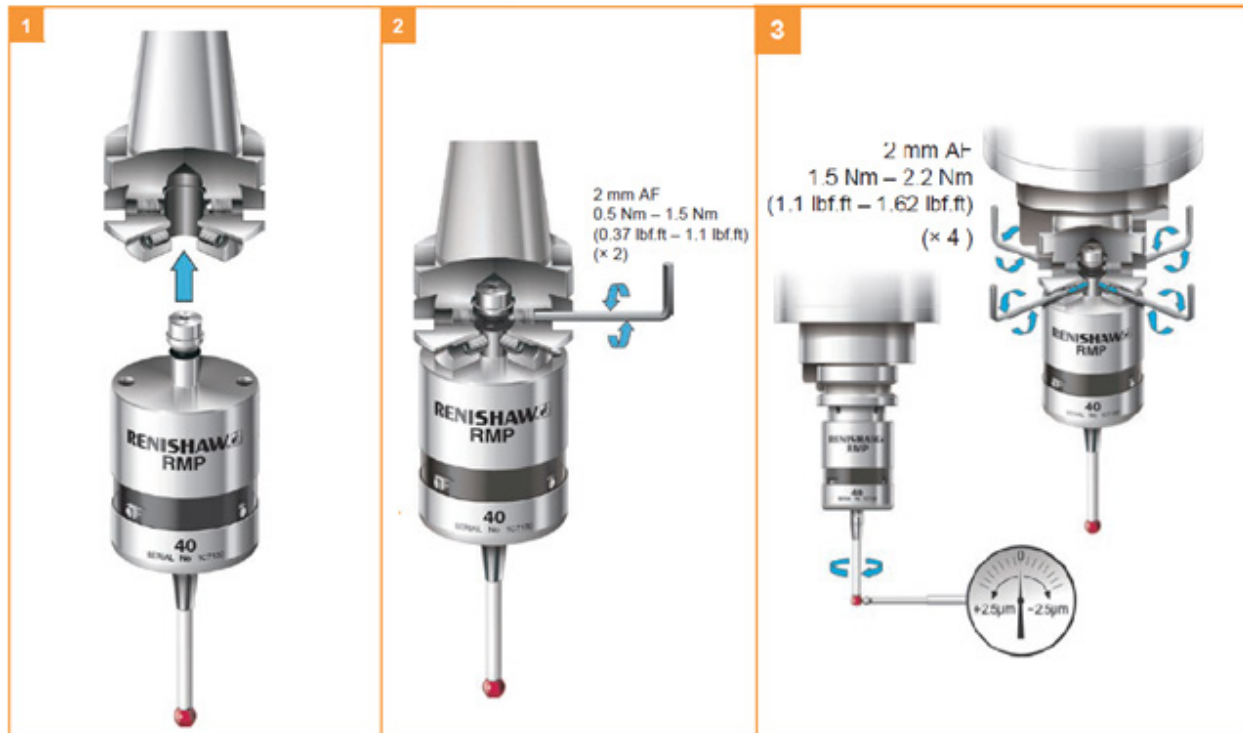

- Dial the probe stylus into center using a .0001" indicator to within .0005" the tighter tolerance you hold the more accurate the machine will be. You must use an indicator that takes very little pressure to get a reading. Excessive pressure on the stylus will deflect the probe and you will not be able to dial it in correctly.
- Go to the Main/Block Model screen and select the Table of Tools. You may only have a Default Tool #0 listed.
- Press Add Tool. This will bring up a dialog box. Change the name from default tool to probe style that you are installing i.e. 50mm stylus, 100mm stylus. Set the diameter to .2360" this is default probe tip on a 50mm, 100mm, and 17.5mm.
- Install a block, or parallels onto the machine and secure it solidly to the machine table.
- Place the Ring Gauge onto the top of the block, use Probe Auto Center to find center zero your X and Y axis here. Make sure you use a ring gauge or a hole of a known diameter. This will set the correct probe timing.
- Adjust the probed diameter by going to the IO under Setup Electronics and changing the Probe MS. You will need to increase or decrease the MS of the probe to achieve correct Probe Diameter.
- Repeat until the correct diameter is displayed.
- Probe Auto Center the ring gauge, without moving X or Y, remove the probe up in Z and Install the cutter head. Put a magnet base with the Last Word indicator on the cutter head and sweep the cylinder/ring gauge.
- The variation in X and Y Should be less than .0005.
- If not add compensation to ProbeOffset under > Setup Eletronics-Addins-ProbeSetup

Leveling and Alignment

The following is a description of how to properly level and align the F69A machine. These procedures should be followed in the order they written to obtain correct machine level and alignment.

Leveling the Machine

After uncrating the F69A set it down in desired location with leveling bolts and leveling pads installed.

Remove the Y-Axis protective rubber located on the backside of the table. This is where you will position the level to level the machine. A .0005" increment per foot precision level is required.

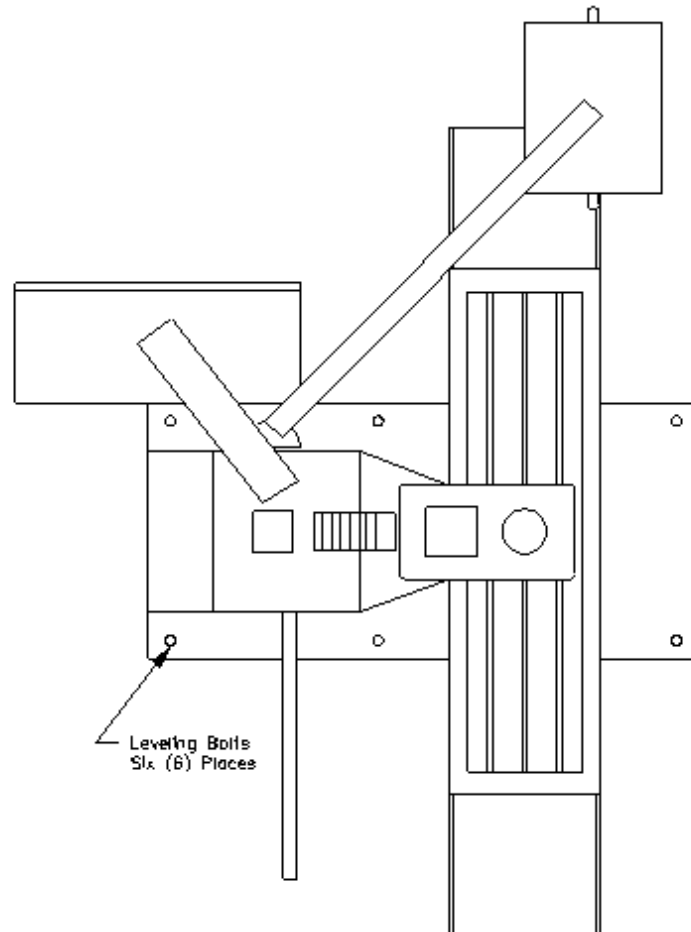

Using the four (4) corner leveling bolt to start with, bring the machine up to level in both directions (front to back and left to right) within .0005" per foot.

After you have leveled the bed using the four corner bolts, move to the middle leveling bolts. Bring these bolts down until they have approximately the same amount of pressure on them as them as the four corner bolts. Be careful not to throw the level of the machine off while doing this.

This will put the lower casting level.

Alignment

Place the alignment cylinder on the table in roughly the same position as shown on the following page.

Note: The position (angle) of the probe to the surface you are indicating is critical. Using an incorrect angle on the probe will result in inaccurate readings from the surface being indicated. The angle of the probe should be at about 15 degrees from the surface being indicated (see illustration 2).

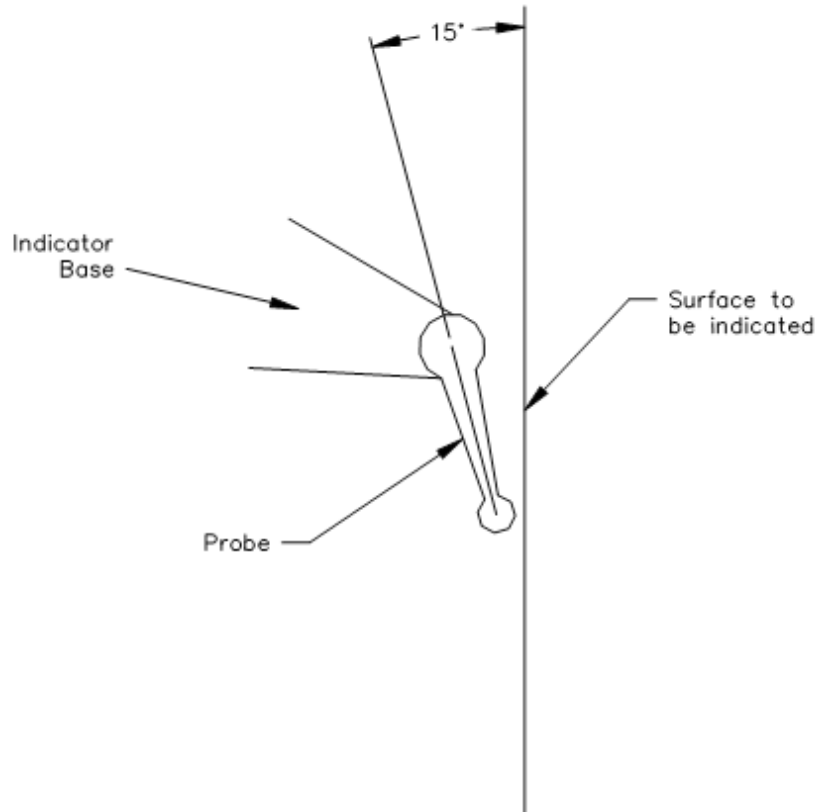

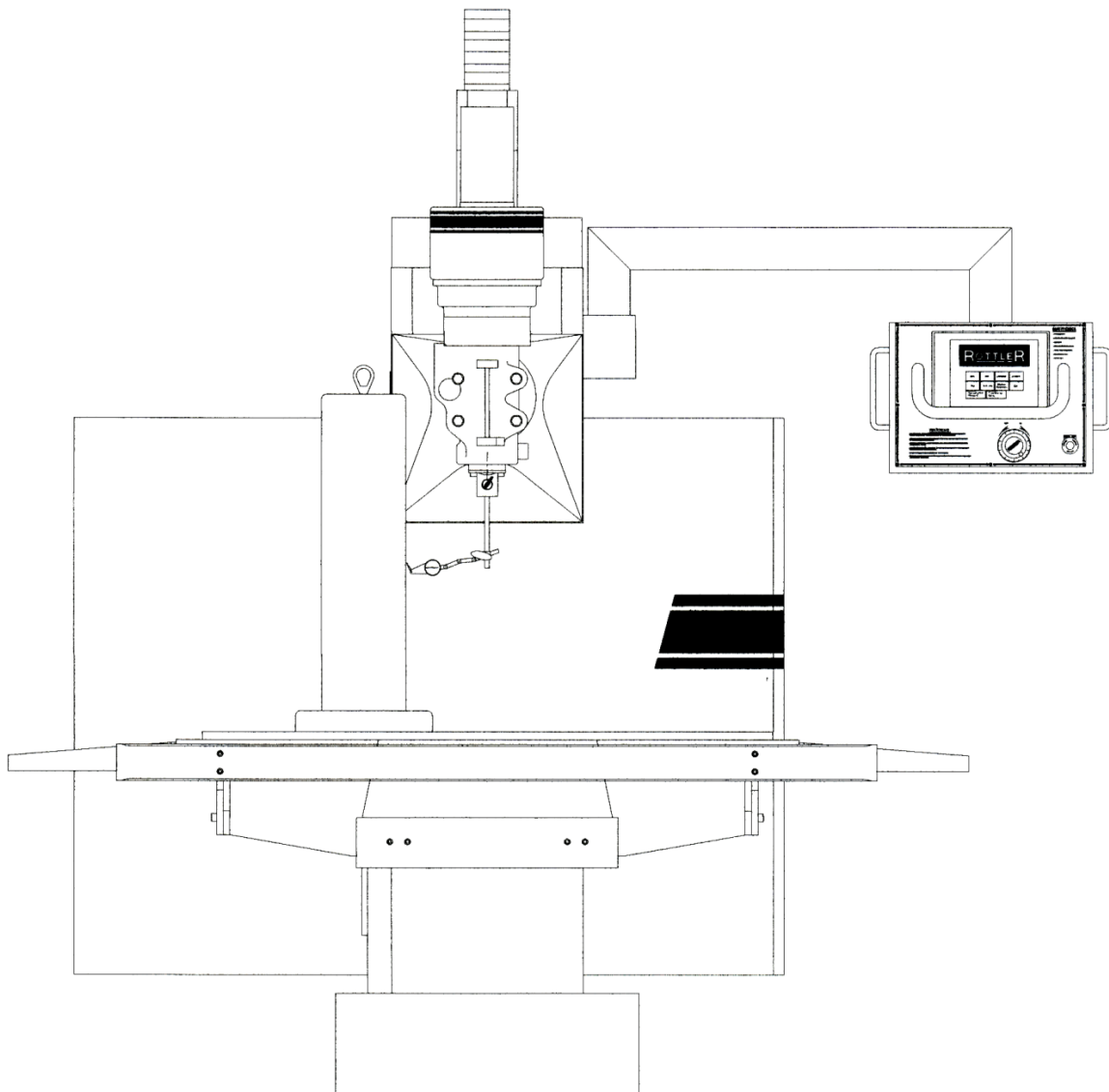

Put about .010" pressure on the indicator. Run the vertical throughout its full travel. The runout should not be more than .0005. If the runout is more than this, check the table top as well as the bottom of the alignment cylinder for burrs or debris.

Move the table out and check the perpendicularity of the vertical ways. This should be within .0005".

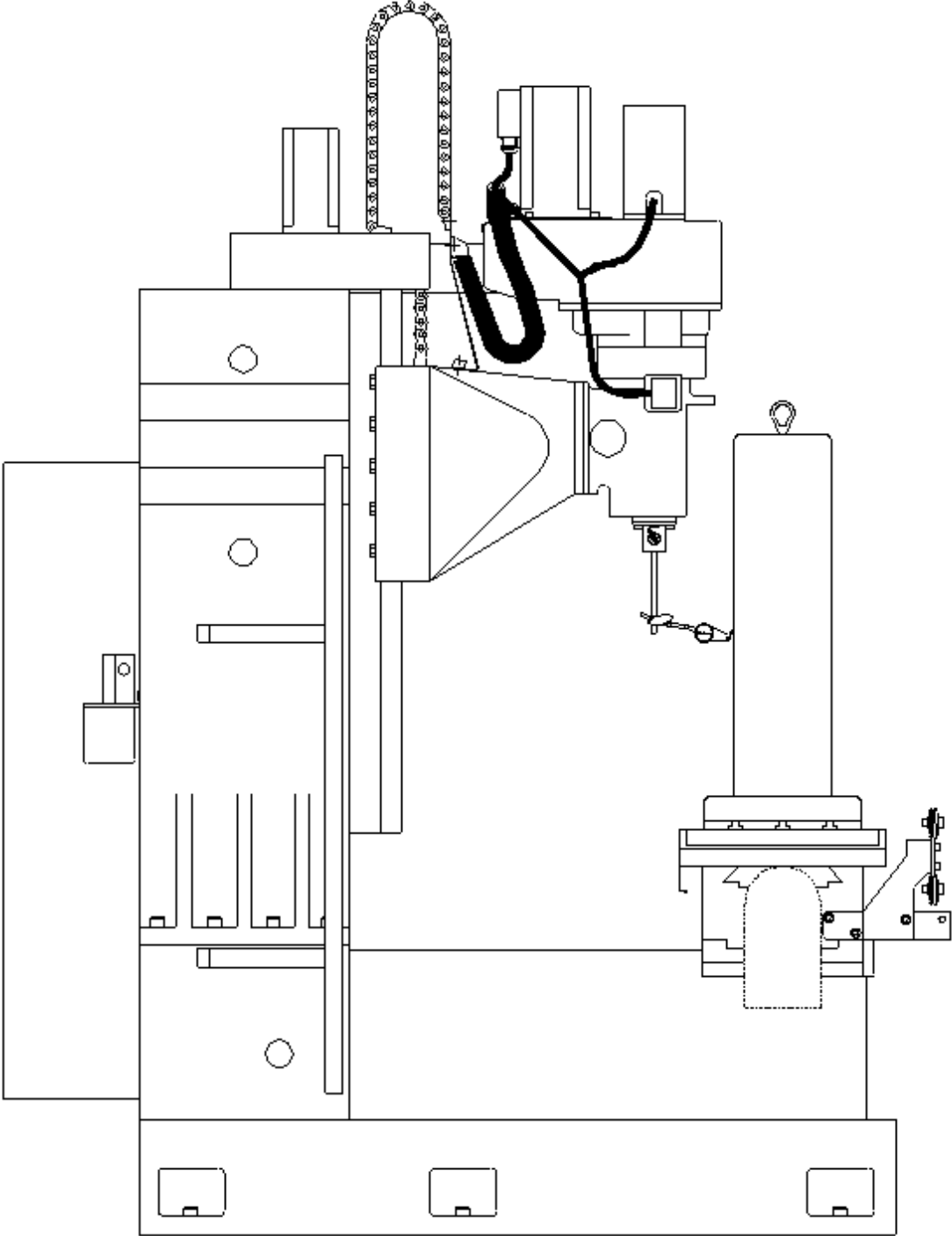

If the Vertical perpendicularity is not within tolerance the Middle Leveling Bolts may need to be adjusted.

Middle Leveling Bolts

If the procedures for the Leveling was followed correctly, it is unlikely that the deviance from Front to Back is being caused by the Middle Leveling Bolts. The following are examples of what could be caused by incorrect pressure on the middle leveling bolts.

Example 1: Zero the indicator on the top of the cylinder. When traveling to the bottom of the cylinder, if the reading decreases past $-.001$ " to something such as $-.002$ ", then the middle leveling bolts have too little pressure on them and it is bowing the casting slightly in the middle as shown below.

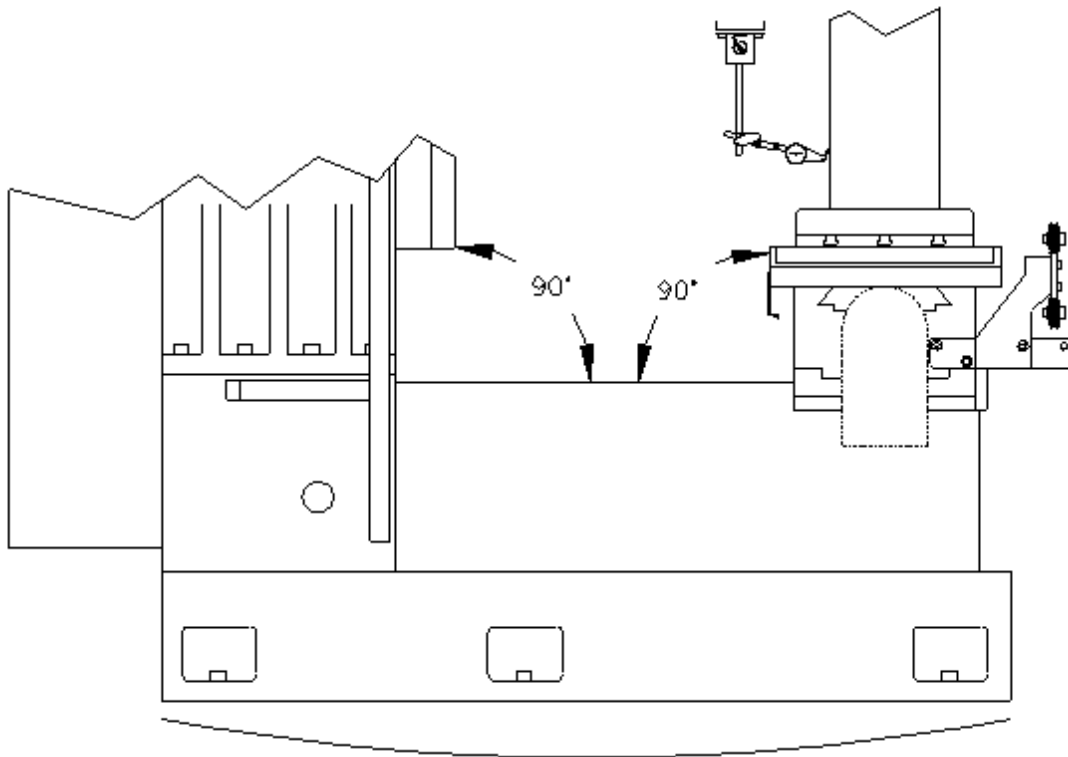

The arched line underneath the picture is illustrating the bow to the casting if the middle leveling bolts have too little pressure on them.

To correct the deviance slowly add pressure to the middle bolts equally. Be sure to watch the level of the machine to be sure not to throw it off. After adding pressure from the middle bolts you can remove pressure from the front and rear corner bolts to bring the deviance within $.001$ ".

Example 2: Zero the indicator on the top of the cylinder. When traveling to the bottom of the cylinder, if the reading decreases past $+.001$ " to something such as $+.002$ ", then the middle leveling bolts have too much pressure on them and it is bowing the casting slightly in the middle as shown below.

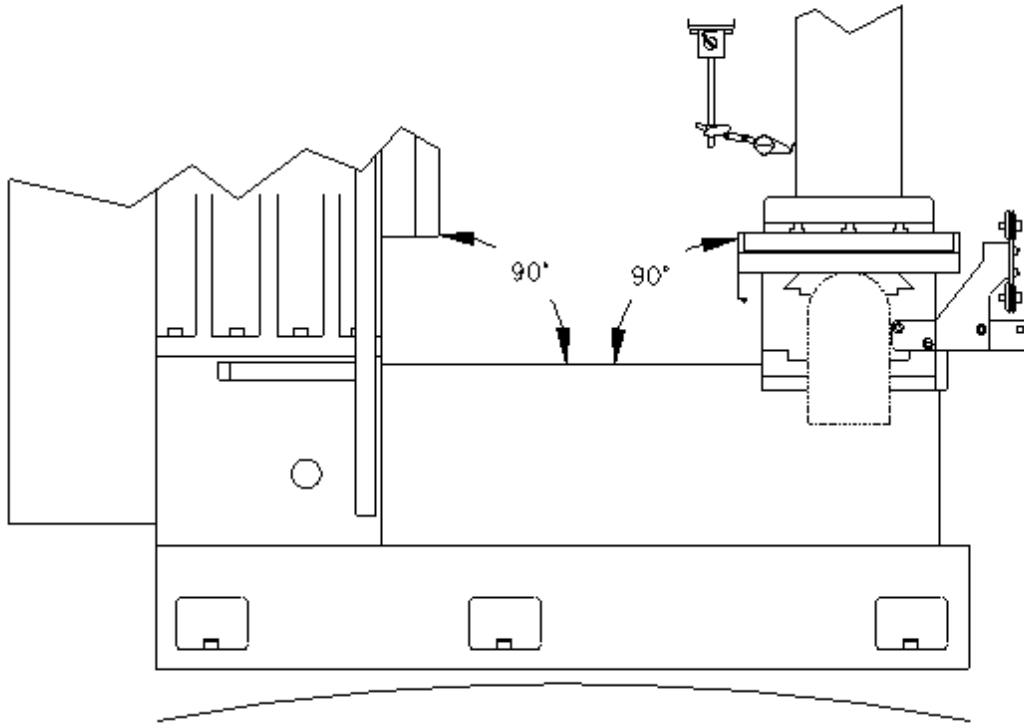

The arched line underneath the picture is illustrating the bow to the casting if the middle leveling bolts have too much pressure on them.

To correct the deviance slowly remove pressure from the middle bolts equally. Be sure to watch the level of the machine to be sure not to throw it off. After relieving pressure from the middle bolts you can apply slightly more pressure to the front corner bolts to bring the deviance within $.001$ ".

Sweeping the Spindle

Remove any fixturing or tooling from the machine table and clean thoroughly.

Attach a magnetic base indicator to the bottom of the spindle. Make sure that the magnetic base is attached in such a way that the spindle is able to be rotated 360 degrees without interference.

Use the following illustration for a visual reference on installing and using the Magnetic base indicator correctly.

Left Side

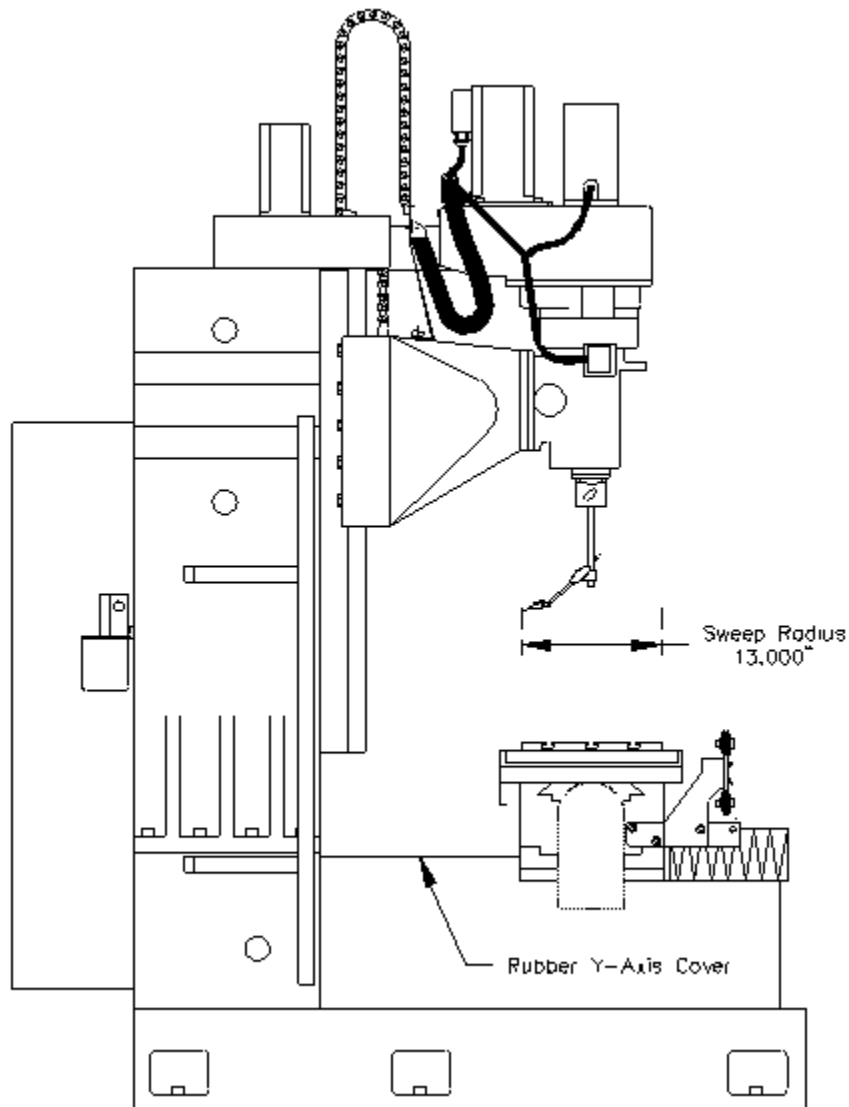

Loosen the four Spindle Main Bolts slightly. Using the Adjustment bolt on the right hand side of the spindle head, sweep the spindle to within $\pm .0002$ Left to Right. Do not worry about the Front to Back reading at this time as the Spindle Main bolts are not tight

Once the Left to Right has been aligned, tighten the Spindle Main Bolts to 80-ft. lbs. Verify the Left to Right sweep again to make sure it did not change while tightening the Spindle Main bolts.

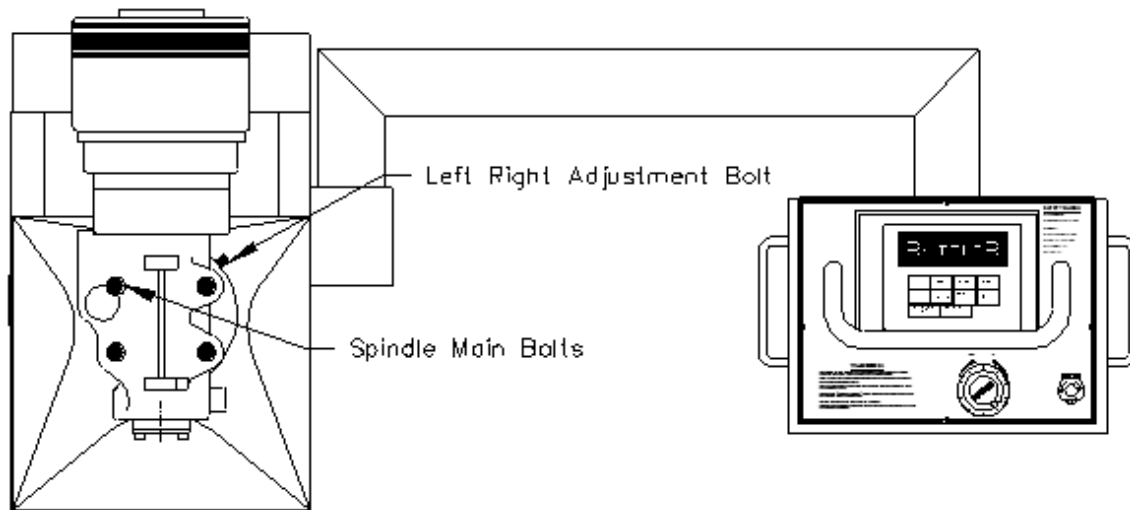

Check the Front to Back sweep it should be within .0005. If it is not, the Vertical gibs may need adjustment.

Vertical Gib Adjustment

Gib adjustments can affect the sweep of the spindle front to back. With the indicator in the 6 O'clock position (as you face the front of the machine) tightening the vertical gibs will lessen the pressure on the indicator probe. Loosening the gib will increase the amount of pressure on the indicator probe.

Example: If you have a reading of 0.0 on the indicator at the 6 O'clock position and $-.002$ " in the 12 O'clock position, tightening the gibs will bring the front of the spindle up. Adjust the gibs until you are within the factory specified $.001$ " deviance.

To adjust the vertical gibs locate the screw at the top and bottom of the gibs.

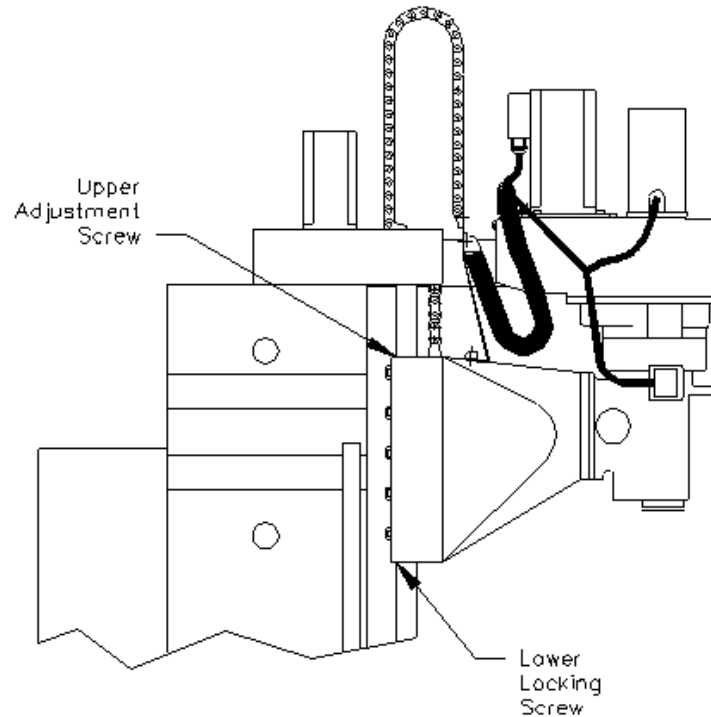

Tightening Gibs

To tighten the gibs, loosen the lower screw. Start tightening the top screw until the correct alignment is achieved. When the correct alignment is achieved, tighten the lower screw to lock the adjustment in place.

Note: *Adjusting the gibs too tight will cause adherence and erratic movement in the vertical travel.*

Loosening Gibs

To loosen the gibs, loosen the top screw. Start tightening the lower screw until the correct alignment is achieved. When the correct alignment is achieved, tighten the upper screw to lock adjustment in place.

Note: *Having the gibs too loose will cause erratic bore size and finish.*

If you do not know how tight or loose the gibs are adjusted, you can remove the way wipers from the top of the gib. When you look in at the gib you will see a horizontal scribe line on most of the gibs. This can be aligned with the internal casting for a starting point. The gibs may need further adjustment at this point. This is only recommended as a starting point.

If there are any questions on this procedure contact Rottler Manufacturing Service Department.

Performance Fixture Line-Up

Install the keys for the Head and Tail Stock into the machine bed as shown below. Place the Head and Tail Stock onto the machine table. Install the hold down bolts but do not tighten them down.

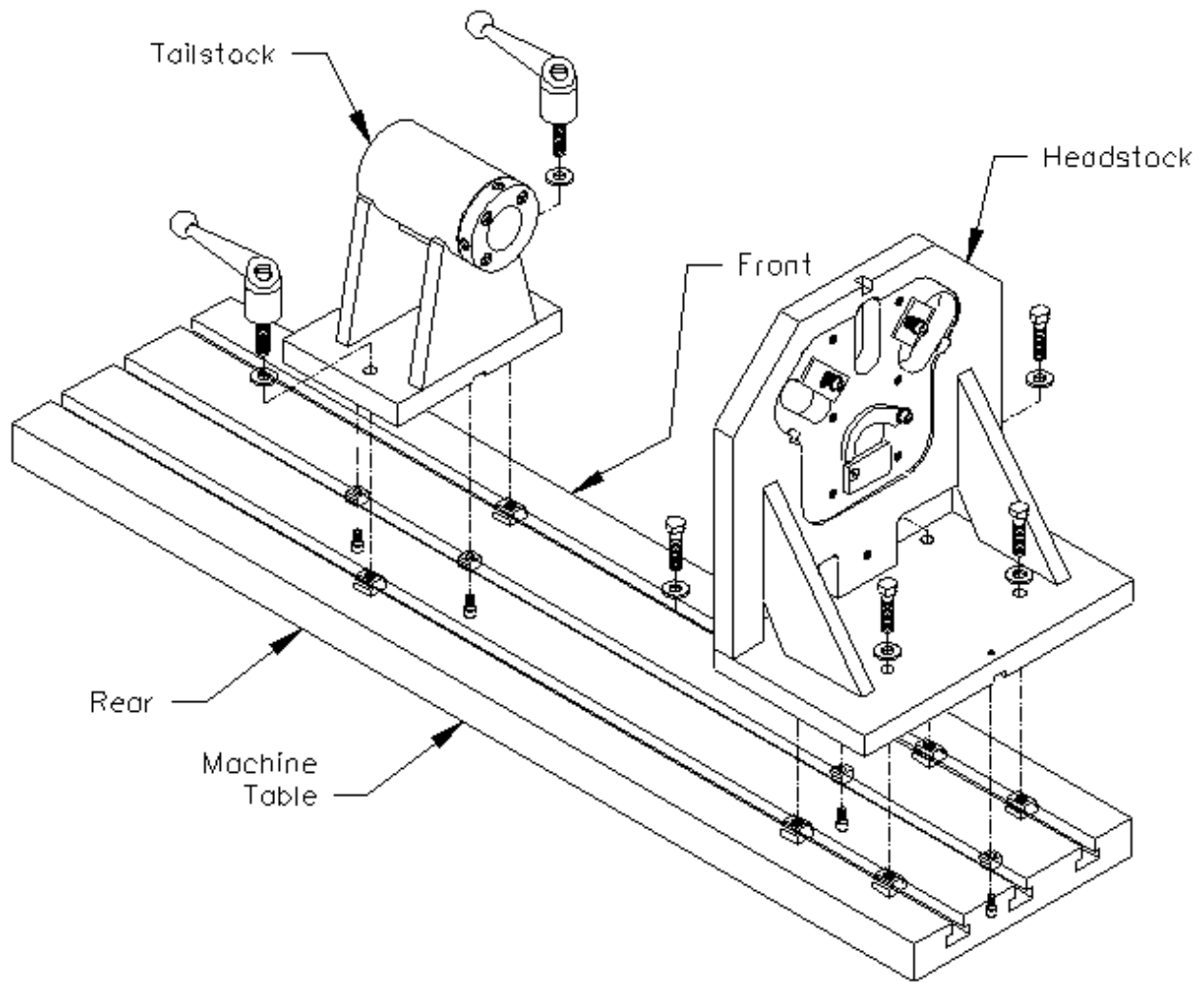

Push the head and tail stock toward the rear of the machine until their keys but up against the table key ways. Snug the hold down bolts and handles. Attach a magnetic base and indicator to the spindle. Run the indicator across the face of the head stock front to back. Adjust the fixture until the indicator runs within .001". Lock the hold down bolts in place. Run the indicator from top to bottom on the head stock. It should be within .001". If it is not, pull the fixture from the table and check for burrs or dings in the head stock and table surface. Be sure there is not debris on the head stock or machine table. Re-install the head stock and follow the previous procedure. Check the face of the head stock again to be sure it did not move while tightening down the bolts.

Install the Main Bar through the tail stock and into the head stock. Run the indicator along the back side of the bar. It should be within .002" through out the travel. Adjust the tail stock in or out as needed to align the bar. Tighten down the locking handles. Run the indicator along the top of the bar. It should be within .002". If it is not, pull the fixture from the table and check for burrs or dings in the tail stock and table surface. Be sure there is not debris on the tail stock or machine table. Re-install the tail stock and follow the previous procedure. Check the bar again to be sure it did not move while tightening down the bolts.

Performance Fixture Line-Up (Cam End Tunnel Boring)

Install the keys for the Head and Tail Stock into the machine bed as shown on previous page. Place the Head and Tail Stock onto the machine table. Install the hold down bolts but do not tighten them down.

The center of the middle table key way needs to be lined up with the center of the Head Stock notch. Using the electronic probe, touch the front side of the middle keyway. Zero the In/Out position. Using the handwheel, move the table out until the probe touches the back side of the key way. Record the numerical reading in the In/Out position box. Divide this number in half, handwheel the In/Out axis until the numerical reading is the same as the halved number. Zero the In/Out axis again. The spindle is now centered over the middle key way. Adjust the head stock In/Out until the center of the Head Stock notch is at the In/Out zero position.

Attach a magnetic base and indicator to the spindle. Run the indicator across the face of the head stock front to back. Adjust the fixture until the indicator runs within .001". Lock the hold down bolts in place. Run the indicator from top to bottom on the head stock. It should be within .001". If it is not, pull the fixture from the table and check for burrs or dings in the head stock and table surface. Be sure there is not debris on the head stock or machine table. Re-install the head stock and follow the previous procedure. Check the face of the head stock again to be sure it did not move while tightening down the bolts.

Mount the End Truing V-End Truing Fixture (650-3-31) to the Head stock. Mount the block to the Truing Fixture. The above procedure has aligned the fixture so the main bore in on the same center line as the middle keyway.

Install the Cam spacer into the middle keyway. Place the bottom Cam Bore on the block over the cam Spacer with the correct bushing installed. This will put the Cam Bore in line with the Main bore.

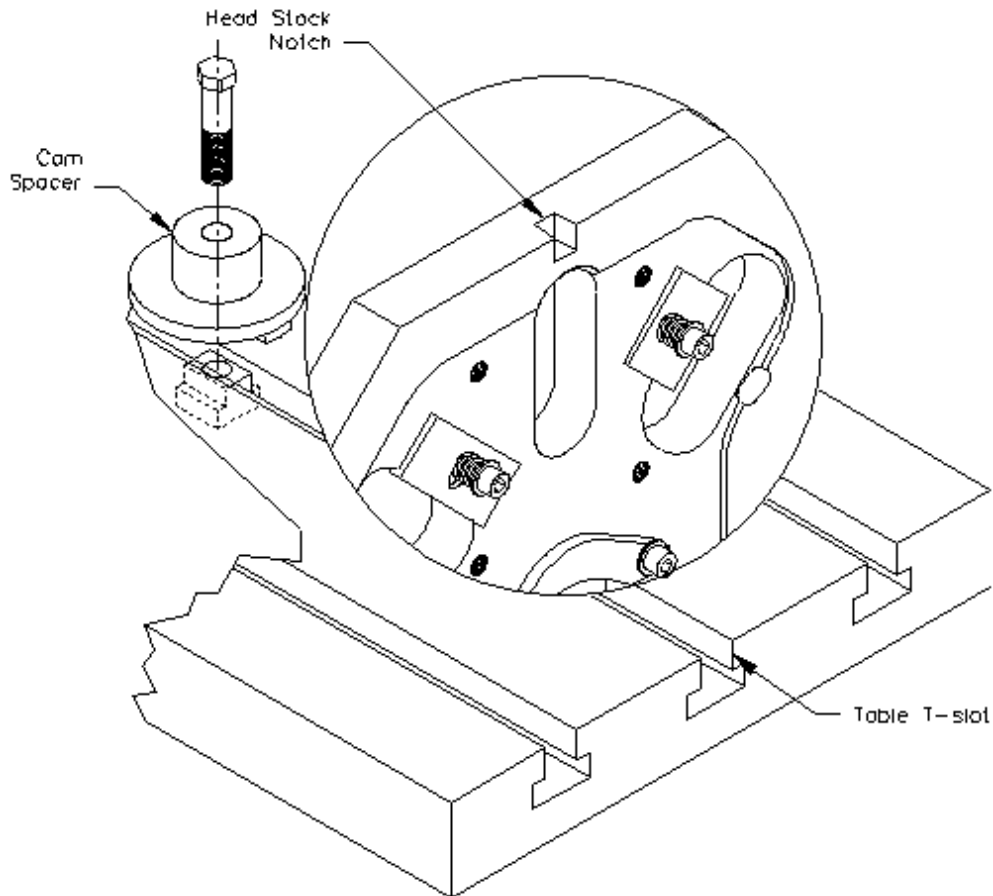

To Copy Block Info From Your Machine

On the machine that has the info to be copied from, with the Rottler program up, go to **file**, click **open**, with the new window open scroll to **local disk C:**, open **rottler**, open **backup 3 axis** (if you have an F90 or a F60 with only 3 axis software) or **backup 4 axis** (if it is newer F60 software or has 4thaxis), open **2008** (or the latest year), open **08** (or the latest month), then pick a date in the following list that comes up (these are constantly added to, they are current dates: **2008** = year, **08** = month), copy it to thumb drive.

To Install Block Info Onto Your Machine

On the machine to copy this to, with the Rottler program up, go to **file**, click **open**, when the new window opens up scroll to USB memory stick and find the copied file, and then open. You will need to select a block and mode, re-input the spindle speed, choose a different mode, so it will ask you if you want to save changes, that is the key.

Replacing the Motherboard Battery

If computer fails to boot up and you get a CMOS error message on the screen, then the battery on the computer motherboard has failed and needs to be replaced.

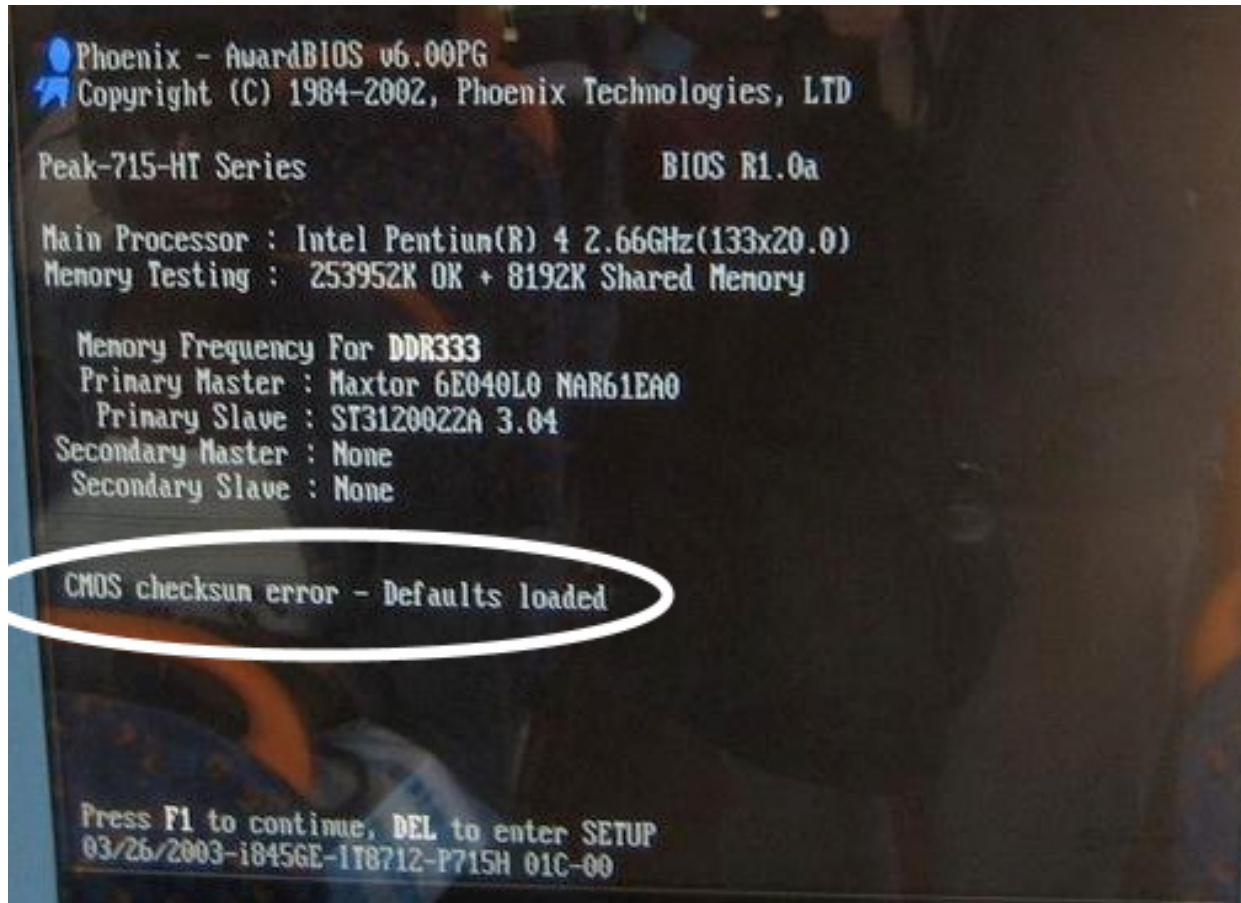

The following is the procedure for replacing the motherboard battery.

Turn off the power on the electrical enclosure and remove the enclosure cover.



Locate the computer and check to see that the power light is not on. If it is on turn off the power switch.
Note: On some machines it may be necessary to unbolt the computer from the enclosure in order to gain access to the cover screws.

Remove the 6 screws indicated by the arrows from the cover.

Remove the cover.



Locate the battery on the motherboard.



Push the battery retention clip away from the battery. When the clip is released the battery will pop up.

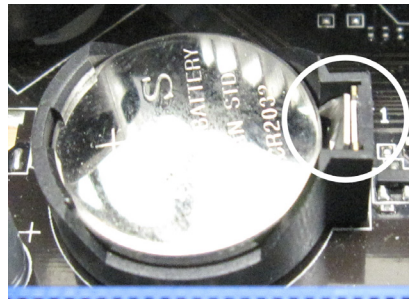

Remove the battery and place new battery in the battery holder.

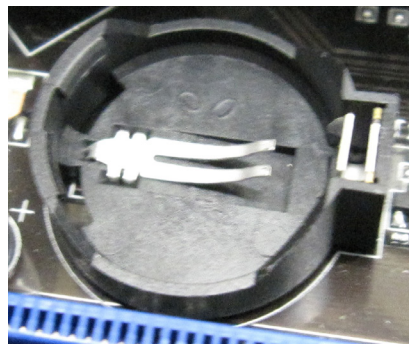

Using your finger tip push down on the battery until the retention clip is in its lock position.



Replace computer cover and make sure that power switch on the computer is on.
Replace the enclosure cover and switch power back on.

Digital Micrometer setting instructions

Turn the thimble until the '0' line on the thimble lines up with the vertical line nearest the spindle lock ring.



Determine which cutter head bore range the micrometer is going to be used on. (example; 2.9 – 6.0)
We want to initially set the micrometer to the minimum bore diameter of this cutterhead.

NOTE: MICROMETER CAN NOT BE PROGRAMMED IF THE LETTERS INC APPEAR IN THE DISPLAY. To get rid of INC, quickly press the in/mm/ABS button.

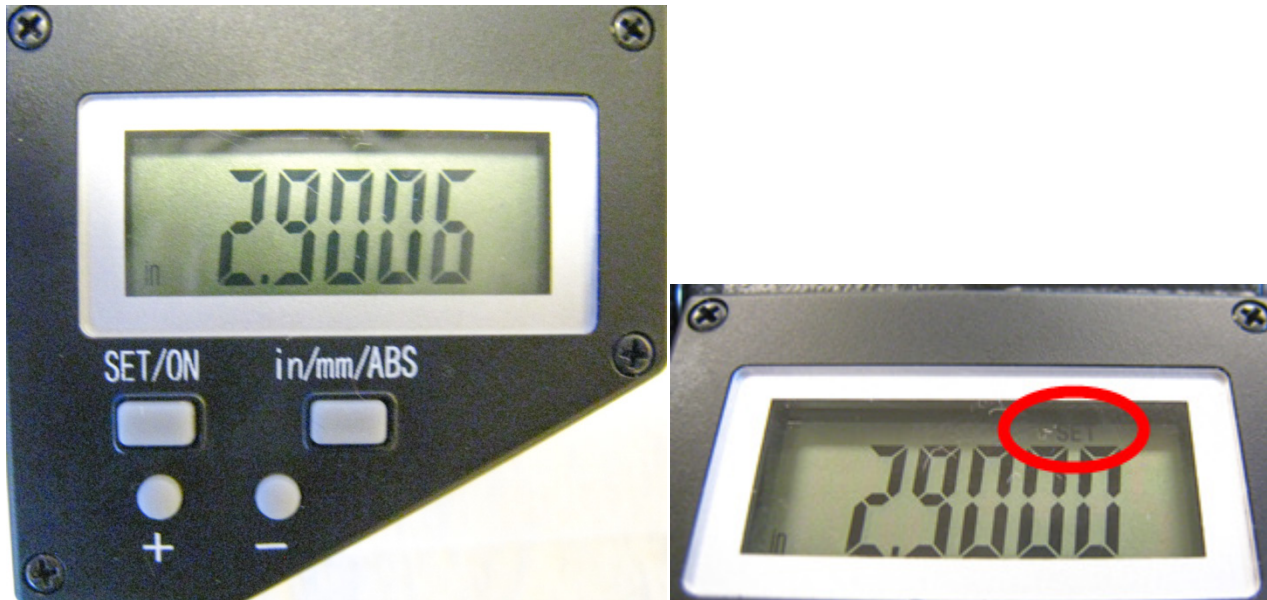

To set or edit micrometer

Press and hold the set/on button and the + or – button at the same time. “Set” will flash in the display. This places the micrometer in edit mode. (**CAUTION:** use a pencil tip or something similar to gently push the small round buttons - they are quite small and a bit delicate.)

Press and hold the + or – buttons to change the display number to the minimum bore diameter determined earlier (example; 2.9). Caution: Pushing the + or – buttons and holding in place will cause the numbers to scroll automatically. The numbers will count slowly at first and once 0.010” has been counted off the scrolling speed will pick dramatically.

After you have reached the desired number in the display, press the set/on button twice quickly to exit the edit mode. “Set” should no longer be flashing in the display. The micrometer is now ready for use.

CAUTION: AFTER MICROMETER SET-UP IS COMPLETE, DO NOT PUSH SET/ON BUTTON AGAIN. PUSHING THE SET/ON BUTTON DURING USE WILL RETURN THE DISPLAY TO THE ORIGINAL MINIMUM BORE DIAMETER. THE ONLY TIME YOU SHOULD USE THE SET/ON BUTTON AGAIN IS TO- A. To shut micrometer off at which time you push and hold the button or B. to turn micrometer display back on at which time you push button one time. The display will then show the last reading before micrometer was shut off.

CAUTION: DO NOT BACK THE THIMBLE ALL THE WAY OUT TO THE END OF IT’S TRAVEL. ONCE THE THIMBLE IS BACKED ALL THE WAY OUT, IT WILL NO LONGER ROTATE PROPERLY AND THE DIGITAL HEAD WILL NEED TO BE REPLACED.

Micrometer is calibrated in inch mode. If metric is desired, press and hold in/mm/ABS button until mode changes to metric (approximately 3-4 seconds). A quick press of the in/mm/ABS button will put micrometer in ABS mode: 0.000, with another quick press returning it to initial setting.

Set up the cutter head and bore a set up hole. Measure the bore accurately. Set the digital display to this bore dimension and then -

Loosen the set screw holding the large diameter anvil. Slide the anvil back out of the way.



Place the tool holder used to bore the hole into the micrometer frame. Slide the location nub on the back of the tool holder gently up against the end of the digital micrometer shaft.



Slide the large diameter anvil up until it touches the end of the cutting tip of the tool holder. Tighten the set screw.





Back the digital micrometer shaft off, then bring it up to touch the tool holder and recheck that the numbers in the display are the same as the numbers previously shown.

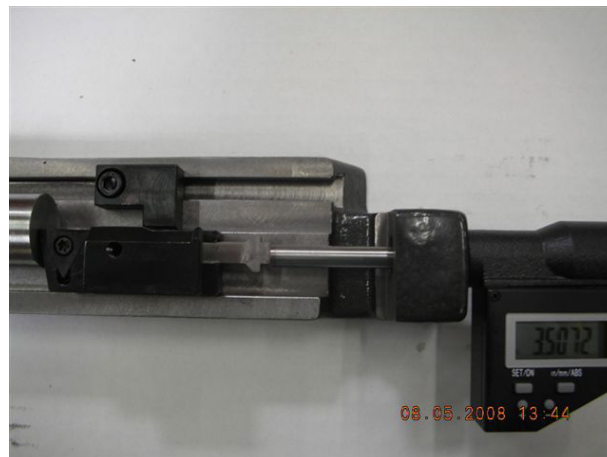

The micrometer is now set up for use with this cutter head.

Note: this procedure must be repeated to set the micrometer to a different cutter head. The micrometer can only be set to one cutter head at a time.

To shut off micrometer press and hold set/on button until screen goes blank or let micrometer set until display disappears.

With initial setting of micrometer it is recommended that you use the procedure detailed below in the event you think you have size problems.

**Procedure:**

The short vertical lines that cross the horizontal scale on the micrometer sleeve are reference marks. Set the zero on the micrometer thimble even with the first vertical line and note the size shown in the digital display. Record this size for future reference. Now follow the same procedure for each line and record the sizes. At any time you feel your micrometer is reading incorrectly, you can quickly refer to the recorded size of the line closest to the range you are using and check that the micrometer is still accurate.

Tool Changer Maintenance

4.1 Lubricate groove of tool claw

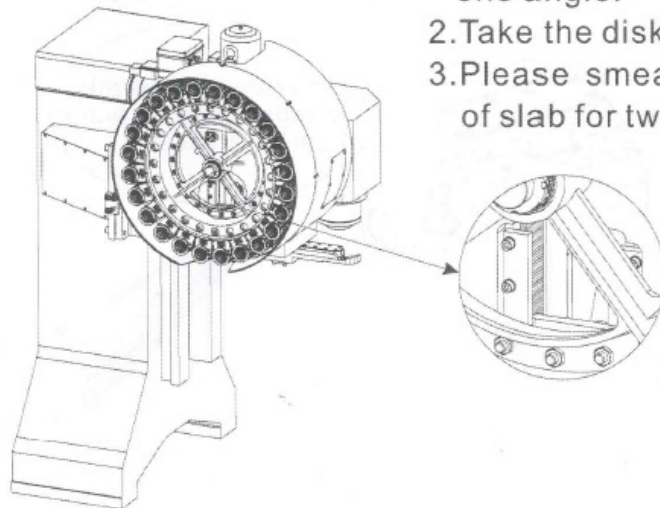

1. Turn off the power before the disk runs one angle.
2. Take the disk cap apart.
3. Please smear lubrication oil on interface of slab for two-side and tool claw.

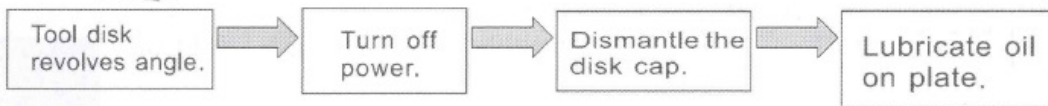

4.2 Tool change cam maintenance

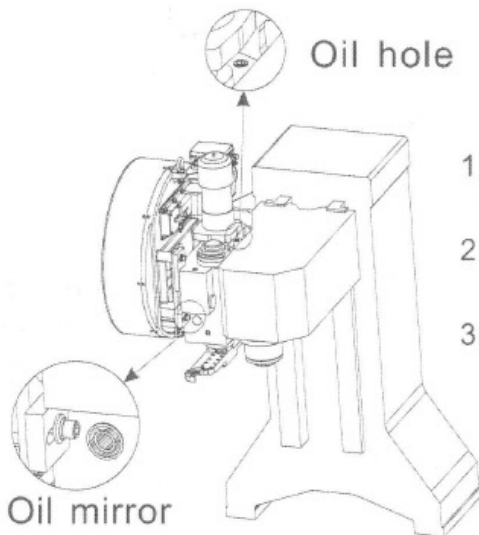

1. Please check if oil quantities is enough. (A half is enough.)
2. Please add EP 150-200 or 85W/90 gear oil when it is not enough.
3. It should make a replacement once a year.

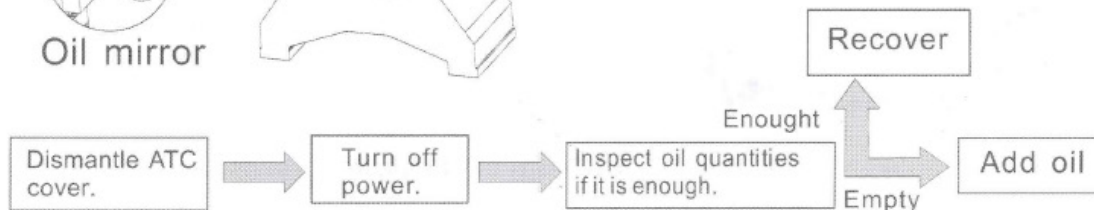

4.9 Inspect the tool pocket supporting cam periodically

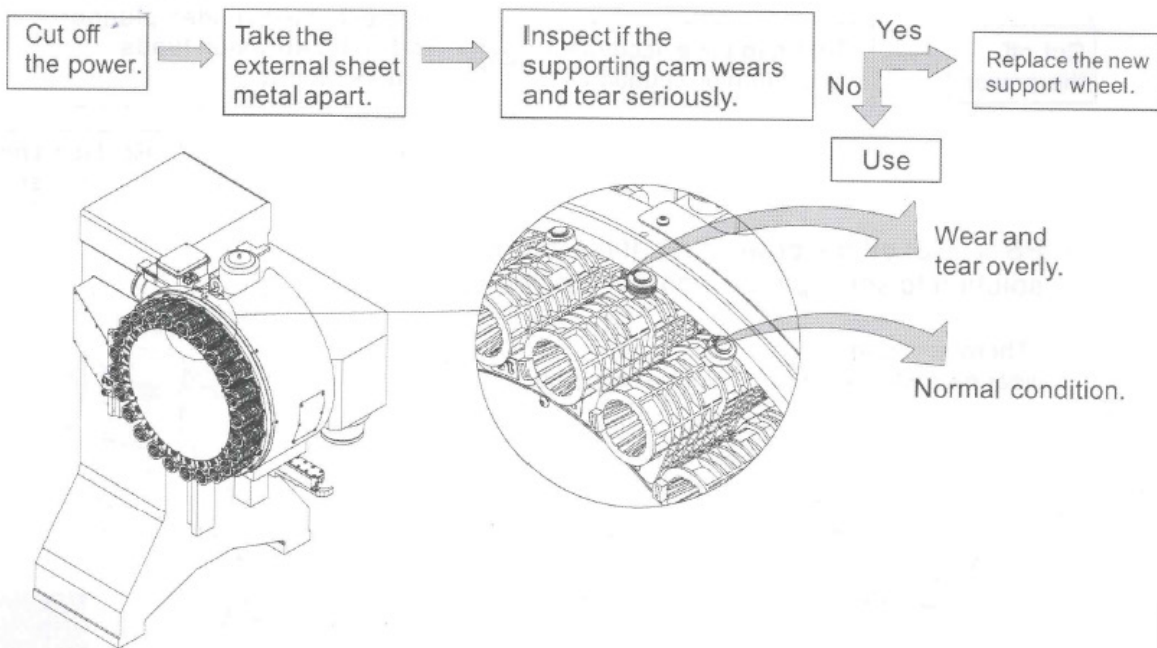

4.10 Inspect the tool pocket pulley periodically

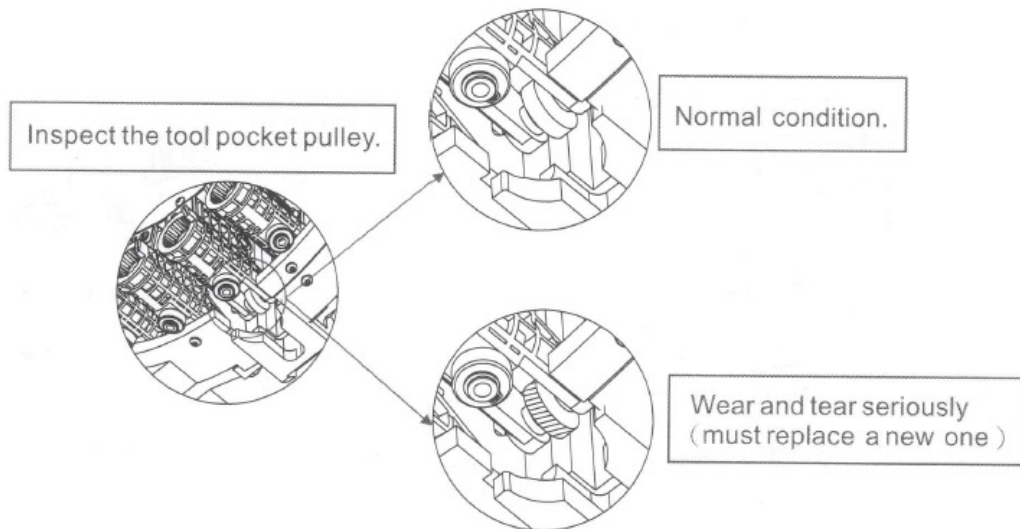

4.11 Inspect Air Cylinder Tappet Periodically

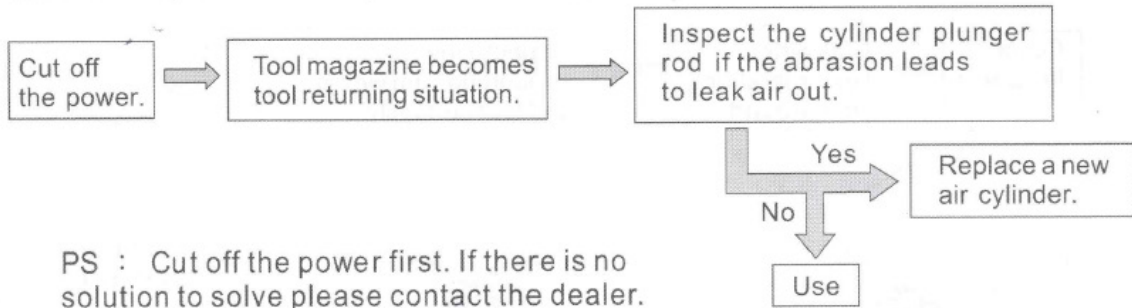

PS : Cut off the power first. If there is no solution to solve please contact the dealer.

There is too much wearing and tearing.

Normal condition.

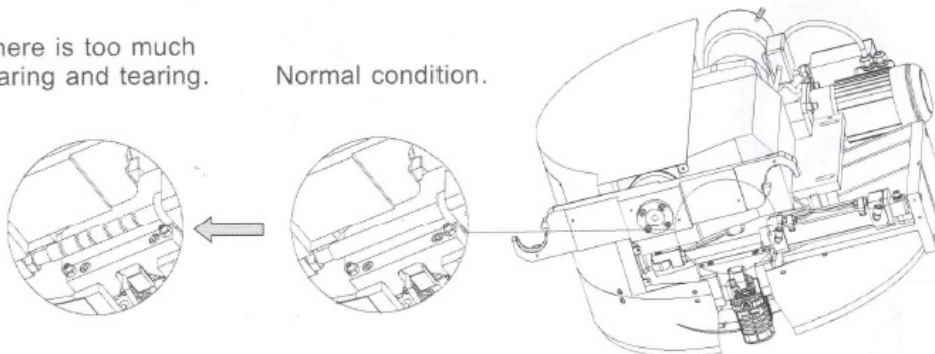

4.12 Sensor adjusting and trouble shooting

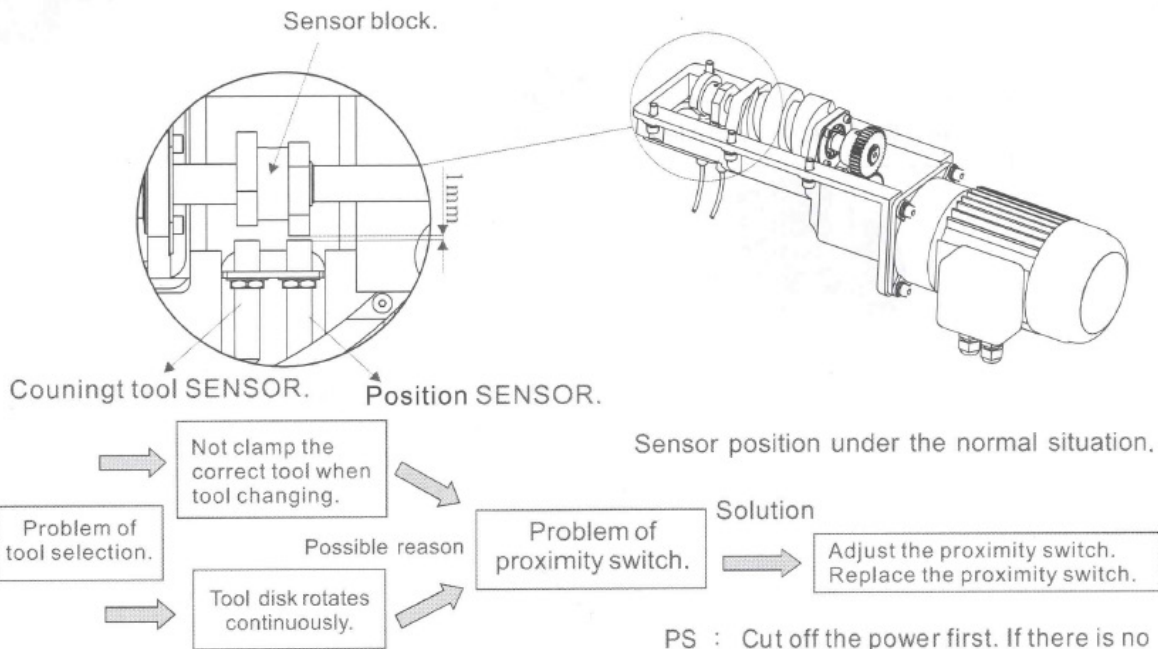

PS : Cut off the power first. If there is no solution to solve please contact the dealer.

4.3 Tool arm maintenance

1. Dismantle the sliding slab and can see chinks beside the arm and sliding block.
2. Fill oil in chinks beside the arm and sliding block.

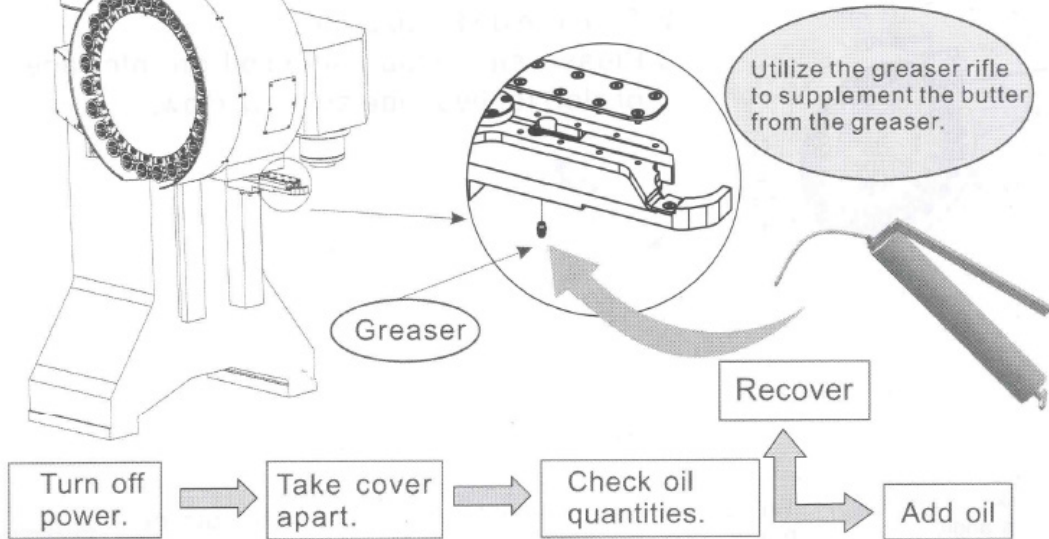

This page intentionally left blank

TROUBLESHOOTING

Contents

Troubleshooting	7-1
Tool Changer Troubleshooting	7-1
Tool change was interrupted and not completed:.....	7-1
Icon on screen does not move to area touched.....	7-4

For further assistance in troubleshooting:

Please visit the service tab of our web page at Send a Service Request www.rottlermfg.com or contact the Rottler Factory Service at service@rottlermfg.com for assistance and your service request.

You may also call Rottler at 1-800-452-0534 or 1-253-872-7050

Please ensure you have the Machine Model and Serial Number available when contacting Rottler for Service

Troubleshooting

Tool Changer Troubleshooting



Tool change was interrupted and not completed:

If a tool change is interrupted and not completed, the machine must be shut down. Disconnect the power supply and remove the air supply from the machine. Remove the tool by hand.

4.4 Eliminate the noise of driving pedestal

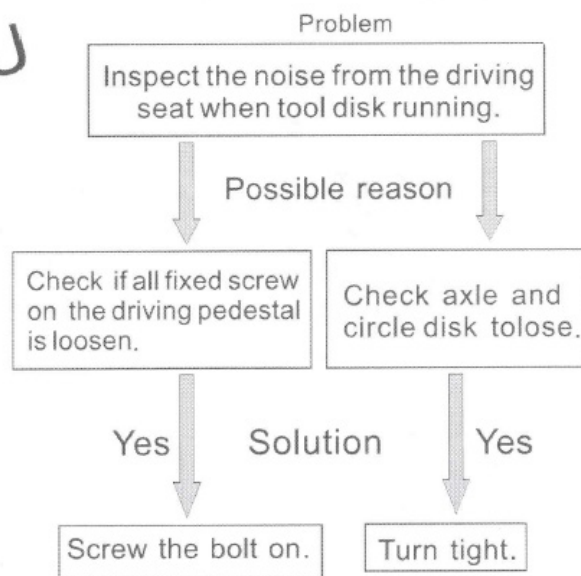
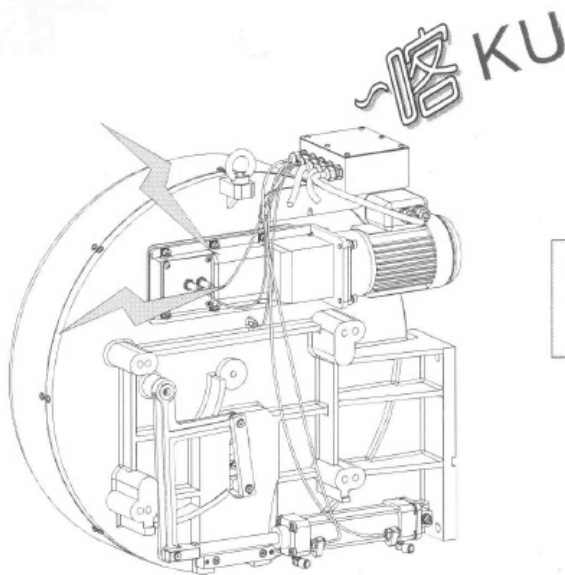

PS : Cut off the power first or contact the dealer.

4.5 Eliminate noise when disk running

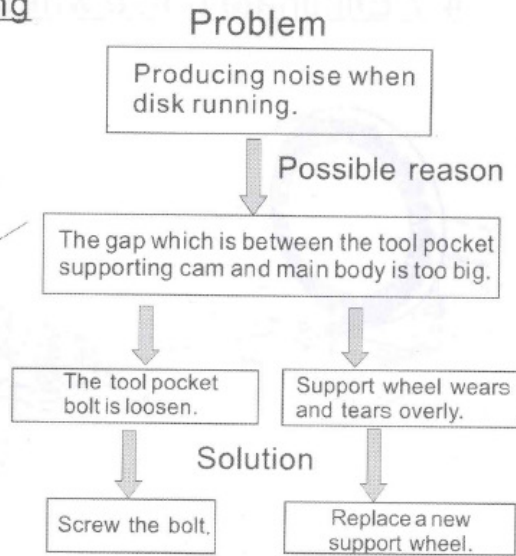
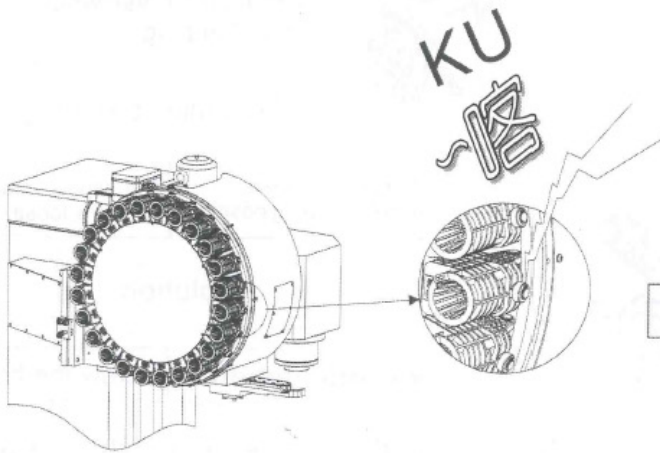

PS : Cut off the power first. If there is no solution to solve please contact the dealer.

4.6 Eliminate noise when tool-tappling

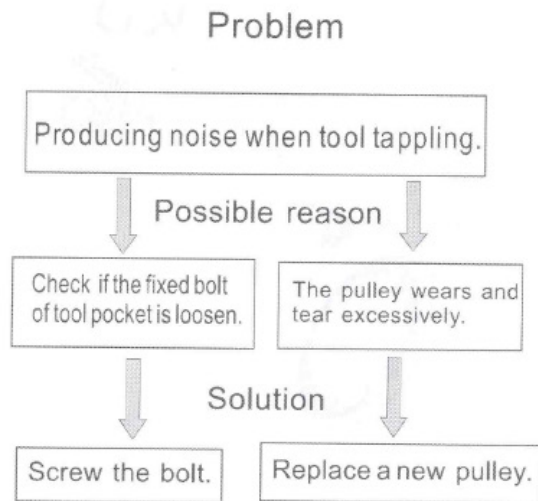
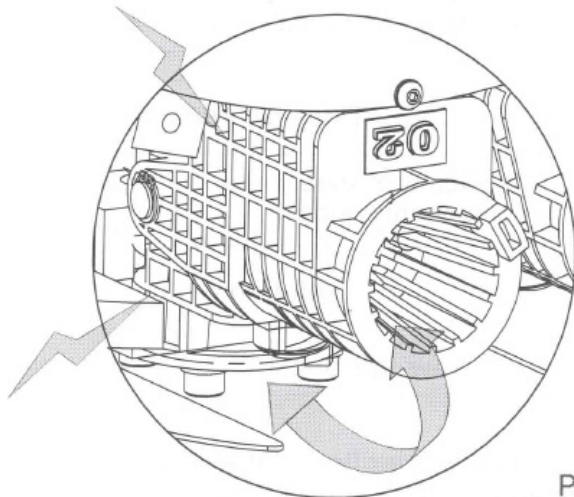

PS : Cut off the power first. If there is no solution to solve please contact the dealer.

4.7 Eliminate noise when tool clamping

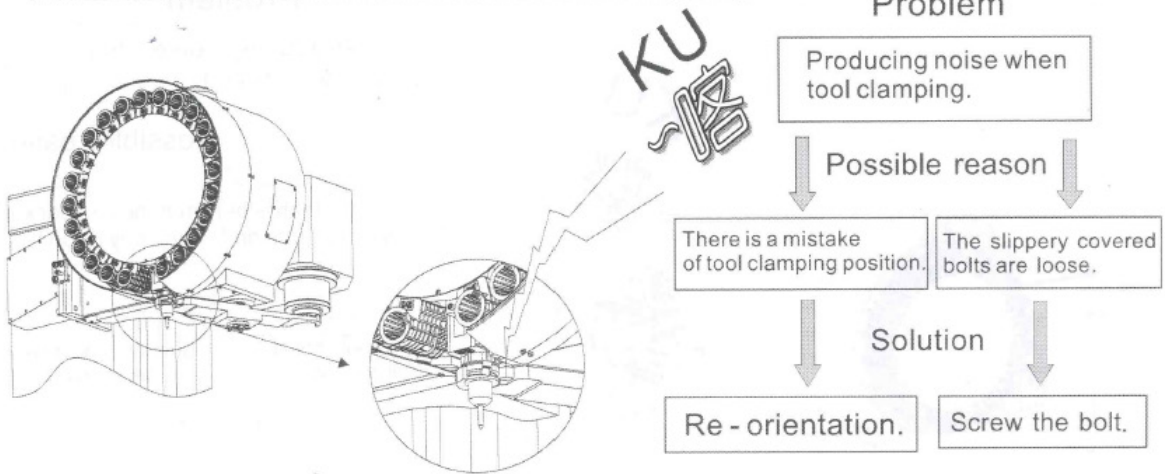

PS : Cut off the power first. If there is no solution to solve please contact the dealer.

4.8 Eliminate noise from the external sheet metal

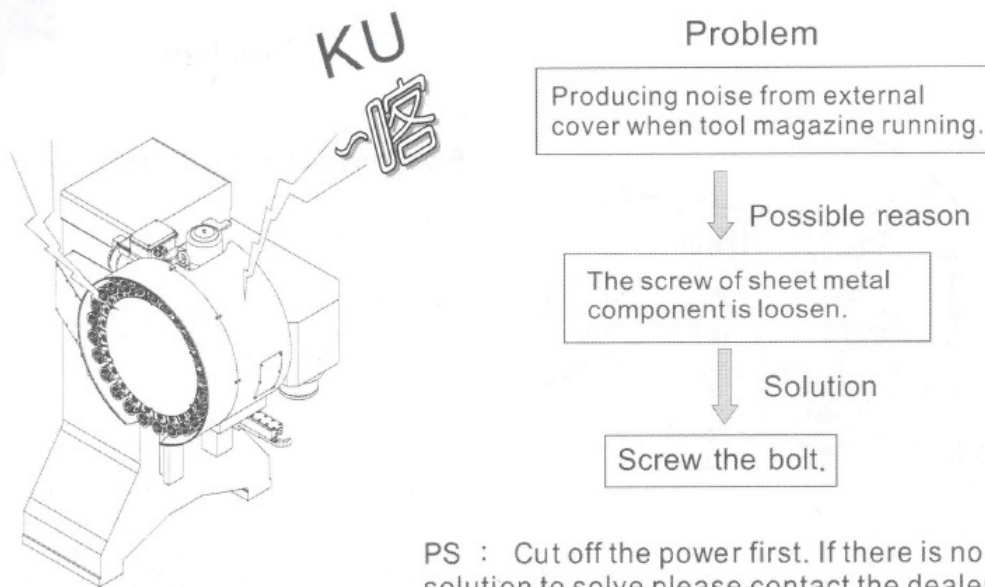

PS : Cut off the power first. If there is no solution to solve please contact the dealer.

Problem:

Icon on screen does not move to area touched.

Solution:

Follow the procedure below to recalibrate the touchscreen.

1. Get to the Alignment screen.
 1. If an Elo icon is available in the tool tray at the lower right side of the desktop, click it, then click Align.
 2. Otherwise, go to the Windows Control Panel, double-click Elo Touchscreen and click the Align button on the General tab.
 1. If Windows XP and no Elo icon, click the "Switch to Classic View" button on the left
 2. If Windows 7 and no Elo icon, look for "View by: Category" text toward the upper right; click it and select "Small icons"
2. Touch and release the upper left target; the target should jump to the lower right.
3. Touch and release the lower right target; the target should jump to the upper right.
4. Touch and release the upper right target; a check screen should appear.
5. Touch and release the green check mark; the check screen should disappear.
6. The cursor should now jump to the point of touch.
7. If the Elo Control Panel is open, close it and the Windows Control Panel.

This page intentionally left blank

MACHINE PARTS

Contents

Rottler Replacement and Specialty Inserts.....	8-1
GENERAL INFORMATION.....	8-1
Tool Nose Radius	8-1
Edge Preparation.....	8-1
Surfacing Inserts Cutting Speed Calculation	8-2
CYLINDER BORING INSERTS	8-2
RT321 (General purpose and sleeving).....	8-2
RT322 (General purpose and sleeving).....	8-3
RTS321 (Steel Cutting).....	8-3
RTS322 (Steel Cutting).....	8-3
RT211 (General purpose and sleeving)	8-4
RT212 (General purpose and sleeving).....	8-4
RT321F (Precision Counterboring and Finishing).....	8-4
RT322F (Precision Counterboring and Finishing).....	8-4
RT211F (Precision Counterboring and Finishing).....	8-5
RT212F (Precision Counterboring and Finishing).....	8-5
RS322 (High speed oversize through boring).....	8-5
6301E (High speed oversize through boring)	8-5
501-29-6K (High speed aluminum boring).....	8-6
511-29-20E (Steel boring).....	8-6
SURFACING INSERTS.....	8-6
6303B	8-6
6303M.....	8-6
6303U	8-6

6303K.....	8-7
RS322.....	8-7
6301J.....	8-7
6303V	8-7
1/2" (12.70mm) SURFACING INSERTS	8-7
6303P	8-7
6303Q	8-7
6864E	8-8
Bi-metal Surfacing.....	8-8
6303S	8-8
6303U	8-8
6303R.....	8-9
6301I.....	8-9
6301V	8-9
7202X.....	8-9
7202Z	8-9
INSERTS FOR SHELL MILLING CUTTERHEADS.....	8-10
6514T	8-10
MAIN LINE BORING INSERTS	8-10
CONNECTING ROD INSERTS.....	8-10
Machine Parts	8-11
F69ATC Front View	8-11
Electrical Panel.....	8-13
Computer 650-7-1	8-14
Computer Components.....	8-15
Accessory Amps	8-16
Axis Amps	8-17

Contactor, Output Board, LG Power Board	8-18
Input Boards	8-19
Spindle Amp	8-20
DIN Rail Components	8-21
Chip Shield Assembly	8-22
Chip Shield Parts	8-23
Base	8-24
Base Parts	8-25
Column and Head	8-26
Column and Head Parts	8-27
Table and Bed	8-28
Table and Bed Parts	8-29
Tool Changer Parts	8-30
Tool Magazine	8-30
Arm Components	8-33
Mounting Assembly	8-35
Wiring Diagram	8-37
Tool Changer Wiring Diagram	8-39
Pneumatic System Diagram	8-40

Rottler Replacement and Specialty Inserts

Below is a description of the cutting inserts available from Rottler. The inserts have gone through extensive performance testing. To take full advantage of the capabilities of your Rottler machine, we highly recommend Rottler cutting tools be used. Rottler machine performance can be significantly reduced if qualified tooling is not used. Using an incorrect insert can result in bore geometry inconsistency, short tool life, and poor surface finish.

Below are general guidelines. When using these inserts it is best to refer to the operator manual of the particular machine you are using. Rottler Manufacturing's latest operator manuals have more detailed information on feeds and speeds for the particular machine and cutterhead that you are using.

GENERAL INFORMATION

Rottler CBN and PCD Inserts are laser marked with our part number on one side. On single sided inserts, the part number is on the back side of the insert.

Rottler surfacing insert toolholders are designed so they can hold square and round inserts that are of the same basic size. For example, a 3/8" (9.52 mm) IC round and 3/8" (9.52 mm) IC square insert will fit into the standard 3/8" (9.52 mm) IC Rottler toolholders. IC refers to inscribed circle.

Rottler SF, F60, F80 and F90 Series surfacing cutterheads are supplied standard with Rottler 3/8" (9.52 mm) IC toolholders fitted to our surfacing heads. Optional 1/2" (12.7 mm) toolholders are interchangeable with 3/8" (9.52 mm) toolholders.

Insert breaking or chipping can be caused by several things. It can be caused by not operating the insert at the correct RPM. It is very typical for an insert to break or chip when cutting too slow. Interrupted cuts can cause an insert to break as well. When making a heavy sleeve cut in a cylinder that has been cracked it is often required to slow the RPM down to 1/2 the normal operating speed to prevent chipping of the insert.

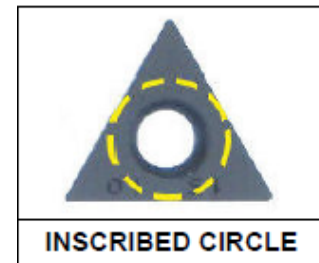

Tool Nose Radius

The tool nose radius has an important effect on the cutting process. If you use the same feed rate per revolution on two different sized tool nose radius the larger tool radius will give a smoother finish. There are two other important characteristics of the tool radius. The larger the tool radius the stronger the cutting edge. The larger radius will hold up to interrupted cuts better than a smaller radius.

A disadvantage of a larger tool radius is that it creates more tool pressure than a smaller radius. When using long small diameter boring bars or large diameter milling cutterheads the high tool pressure of a large radius can cause chatter in the finish.

Edge Preparation

Rottler inserts have edge preparations specifically designed for proper cutting performance. Some inserts have sharp edges, some have a few ten thousandths of an inch honed edge. Others have a T land which is actually a beveled edge. Generally the sharp edge will require the minimum amount of cutting pressure but the edge will not be as strong and long lasting. The T land insert is at the opposite end of the spectrum. It generates a lot of cutting force and can create chatter. The advantage of a T land is that it is very tough. Most Rottler inserts have a honed edge which gives a good balance between cutting performance and tool life.

Surfacing Inserts Cutting Speed Calculation

Inserts are designed to cut within a speed range – SFPM. In order to convert from cutting speed to RPM, use the following formula:

$$\text{RPM} = \frac{\text{SFPM} \times 3.82}{\text{DIAMETER}}$$

SFPM = Surface Feet per Minute

RPM = Revolutions per Minute

DIAMETER in Inches

The feed rate on most Rottler machines is designated in inches / revolution. The F65M and the SFM have feed rates designated in inches / minute. It is important to adjust the inches / minute rate to obtain the correct load (inches / revolution). Following are the formulas to use. You do not have to perform this calculation with an “A” model machine

If you know the RPM and the Feed Rate per Revolution you want, use the following formula to obtain the correct Feed Rate per minute.

$$\text{FRM} = \text{RPM} \times \text{FRR}$$

FRM = Feed Rate Inches per Minute

FRR = Feed Rate Inches per Revolution

RPM = Spindle Revolutions per Minute

METRIC CONVERSION
1 inch = 25.4mm = 2.54cm
1mm = .040 inches

CYLINDER BORING INSERTS

Rottler has just completed the development of group of new triangular inserts for cylinder boring. Extensive trials were made to come up with new inserts that would outperform the older inserts. The result is a group of inserts that are the same unit cost but have 5 – 50% increased tool life. The increased tool life decreases overall operation cost to the end user.

Rottler offers either triangular or square inserts for cylinder boring, sleeving, and counter boring. Triangular inserts are excellent general purpose inserts for doing all boring, sleeving and counterboring operations. When doing counter boring operations it is important to use a tool nose radius small enough that it will not interfere with the mating corner on the part that is installed in the counterbore.

When removing less than .060” (1.50mm) on the diameter a square insert is the most economical insert to use. The square inserts Rottler offers have 8 cutting edges. A Triangular insert only has 3 cutting edges.

RT321 (General purpose and sleeving)



A 3/8” (9.52 mm) IC triangular insert with a black ceramic coating and 1/64” (.4 mm) cutting radius. This insert is the best to use for counterboring when the small corner radius is required for clearance or when the machine is at its extended travel limits.

The 1/64” (.4 mm) radius should be used when machining to a step where the mating part requires a smaller radius to eliminate an interference problem in the radius. If you are machining a long bore where the spindle must be extended towards the limits of its travel or if a long stub bar is being used, the 1/64” (.4 mm) radius will minimize the possibility of chatter. A feed rate of .002” - .005” (.05 mm - .12 mm) per revolution should be used to obtain a typical surface finish. When machining large counter bores typically found in Cummins or Cat Blocks, a feed rate of .002” - .004”/rev (.02 mm-.1 mm/rev) should be used. When cutting gray cast iron use a speed in the 800 – 1200 SFPM area for best productivity and tool life.

When cutting nodular, ductile, or compacted graphite cast iron the speed should be in the 200 – 400 SFPM area – 300 RPM on a 4" (100 mm) diameter bore. Nodular, ductile, or compacted graphite cast irons, is found most often in high performance engine blocks or sleeves. When cutting these tough cast irons it is best to use a feed rate of between .002 and .005 (.05 mm and .13 mm) per revolution.

RT322 (General purpose and sleeving)



This is the same insert as RT321, except it has a 1/32" (.8 mm) radius. This insert is the best to use for heavy sleeve cutting and can also be used for general machining and counterboring. This larger radius insert will give a smoother finish for a given feed rate when sleeve cutting to allow easier sleeve fitting and closer metal to metal contact for heat transfer. It is possible to use a feed rate that is 30% faster with the RT322 compared with the RT321 and still obtain the same finish. The 1/32" (.8 mm) radius is stronger than the 1/64 (.4mm) radius of the RT321. The RT322 should always be used for heavy sleeve cuts unless the finish part requires the smaller radius for clearance or you are cutting a long bore. The larger radius creates more tool pressure than the small radius. The increased tool pressure may cause chatter in the finish if machining very long bores. A feed rate of .006" - .012" (.15 mm - .3 mm) per revolution should be used to obtain a typical surface finish. When machining large counter bores typically found in Cummins or Cat Blocks, a feed rate of .002" - .004"/rev (.05 mm-.1 mm/rev) should be used. When cutting gray cast iron use a speed in the 800 – 1200 SFPM area for best productivity and tool life.

When cutting nodular, ductile, or compacted graphite cast iron the speed should be in the 200 – 400 SFPM area – 300 RPM on a 4" (100 mm) diameter bore. Nodular, ductile, or compacted graphite cast irons, is found most often in high performance engine blocks or sleeves. When cutting these tough cast irons it is best to use a feed rate of between .006" and .010" (.15 mm and .25 mm) per revolution.

RTS321 (Steel Cutting)



A 3/8" (9.52 mm) IC triangular insert with a grey ceramic coating and 1/64" (.4 mm) cutting radius. This insert is the best to for cutting steel. It has a chip breaker to break steel chips. If you are machining a long bore where the spindle must be extended towards the limits of its travel or if a long stub bar is being used, the 1/64" (.4 mm) radius will minimize the possibility of chatter. A feed rate of .002" - .005" (.05 mm - .12 mm) per revolution should be used to obtain a typical surface finish. When cutting mild steel use a speed in the 400 – 1000 SFPM area for best productivity and tool life. This insert should not be used for cutting cast iron.

Note: When using this insert it is required to use a "0" degree rake cartridge.

RTS322 (Steel Cutting)



A 3/8" (9.52 mm) IC triangular insert with a grey ceramic coating and 1/32" (.8 mm) cutting radius. This insert is the best to for cutting steel. It has a chip breaker to break steel chips. A feed rate of .003" - .008" (.05 mm - .12 mm) per revolution should be used to obtain a typical surface finish. When cutting mild steel use a speed in the 400 – 1000 SFPM area for best productivity and tool life. This insert should not be used for cutting cast iron.

Note: When using this insert it is required to use a "0" degree rake cartridge.

RT211 (General purpose and sleeving)

A 1/4" (6.35 mm) IC triangular insert with a black ceramic coating and 1/64" (.4 mm) cutting radius. The 1/64" (.4 mm) radius should be used when machining to a step where the mating part requires a smaller radius to eliminate an interference problem. If you are machining a long bore where the spindle must be extended towards the limits of its travel or if a long stub bar is being used, the 1/64" (.4 mm) radius will minimize the possibility of chatter. A feed rate of .002" - .005" (.05 mm - .12 mm) should be used to obtain a typical surface finish. When machining large counter bores typically found in Cummins or Cat Blocks, a feed rate of .002" - .004"/rev. (.05 mm - .1 mm/rev) should be used. When cutting gray cast iron use a speed in the 800 – 1200 SFPM area for best productivity and tool life.

When cutting nodular, ductile, or compacted graphite cast iron the speed should be in the 200 – 400 SFPM area – 300 RPM on a 4" (100 mm) diameter bore. Nodular, ductile, or compacted graphite cast irons, is found most often in high performance engine blocks or sleeves. When cutting these tough cast irons it is best to use a feed rate of between .002 and .005 (.05 mm and .13 mm) per revolution.

RT212 (General purpose and sleeving)

This is the same insert as RT212, except it has a 1/32" (.8 mm) radius. This larger radius insert will give a smoother finish when sleeve cutting to allow easier sleeve fitting and closer metal to metal contact for heat transfer. The 1/32" (.8 mm) radius is stronger than the 1/64 (.4 mm) radius of the RT321. The RT322 should always be used for sleeve cuts unless the finish part requires the smaller radius for clearance or you are cutting a long bore. The larger radius creates more tool pressure than the small tool radius. The increased tool pressure will create chatter in the finish. A feed rate of .006" - .012" (.15 mm - .3 mm) per revolution should be used to obtain a typical surface finish. When machining large counter bores typically found in Cummins or Cat Blocks, a feed rate of .002" - .004"/rev. (.05 mm - .1 mm/rev) should be used. When cutting gray cast iron use a speed in the 800 – 1200 SFPM area for best productivity and tool life. When cutting nodular, ductile, or compacted graphite cast iron the speed should be in the 200 – 400 SFPM area – 300 RPM on a 4" (100 mm) diameter bore. Nodular, ductile, or compacted graphite cast iron is found most often in high performance engine blocks or sleeves. When cutting these tuff cast irons it is best to use a feed rate of between .006" and .010" (.15 mm and .25 mm) per revolution.

RT321F (Precision Counterboring and Finishing)

A 3/8" (9.52 mm) IC triangular, uncoated insert with a 1/64" (.4 mm) cutting radius. Gives the best finish results when machining precision counter bores often machined in diesel engine blocks. The 1/64" (.4 mm) radius should be used when machining to a step where the mating part requires a smaller radius to eliminate an interference problem. If you are machining a long bore where the spindle must be extended towards the limits of its travel or if a long stub bar is being used, the 1/64" (.4 mm) radius will minimize the possibility of chatter. A feed rate of .002" - .005" (.05 mm - .12 mm) should be used to obtain a typical surface finish. When machining large counter bores typically found in Cummins or Cat Blocks, a feed rate of .002 - .004/rev. (.05 mm - .1 mm/rev) should be used.

RT322F (Precision Counterboring and Finishing)

A 3/8" (9.52 mm) IC triangular, uncoated insert with a 1/32" (1.6 mm) cutting radius. Gives the best finish results when machining precision counter bores often machined in diesel engine blocks. A feed rate of .004" - .008" (.05 mm - .1 mm) should be used to obtain a typical surface finish. When machining large counter bores typically found in Cummins or Cat Blocks, a feed rate of .002 - .004/rev. (.05 mm - .1 mm/rev) should be used. When cutting gray cast iron use a speed in the 300 - 600 SFPM area for best productivity and tool life. Tool life of this insert is significantly less than the RT322.

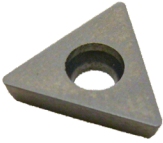
RT211F (Precision Counterboring and Finishing)

A 1/4" (6.35 mm) IC triangular, uncoated insert with a 1/64" (.8 mm) cutting radius. Gives the best finish results when machining precision counter bores often machined in diesel engine blocks. The 1/64" (.8 mm) radius should be used when machining to a step where the mating part requires a smaller radius to eliminate an interference problem. If you are machining a long bore where the spindle must be extended towards the limits of its travel or if a long stub bar is being used, the 1/64" (.8 mm) radius will minimize the possibility of chatter. A feed rate of .002 - .005 (.05 mm - .12 mm) should be used to obtain a typical surface finish. When machining large counter bores typically found in Cummins or Cat Blocks, a feed rate of .002 - .004/rev. (.05 mm - .1 mm) should be used. When cutting gray cast iron use a speed in the 300 - 600 SFPM area for best productivity and tool life. Tool life of this insert is significantly less than the RT211

RT212F (Precision Counterboring and Finishing)

A 1/4" (6.35 mm) IC triangular insert with a gold coating and 1/32" (1.6 mm) cutting radius. The coating gives the best finish results when machining precision counter bores often machined in diesel engine blocks. A feed rate of .002 - .005 (.05 mm - .12 mm) should be used to obtain a typical surface finish. When machining large counter bores typically found in Cummins or Cat Blocks, a feed rate of .002 - .004/rev. (.05 mm - .1 mm/rev.) should be used. When cutting gray cast iron use a speed in the 300 - 800 SFPM area for best productivity and tool life. Tool life of this insert is significantly less than the RT211. RS322 (High speed oversize through boring)

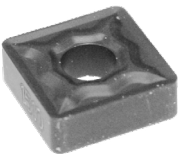
RS322 (High speed oversize through boring)

A 3/8" (9.52 mm) IC, square insert with a black ceramic coating. It is used on Rottler boring machines for through boring when removing .010" - .060" (.25 mm - 1.5 mm) on the diameter. A very economical insert as it has 8 cutting edges. On a 4" (100mm) bore use 1000 - 1200 RPM and a feed rate of .008" - .012" (.2 mm - .3 mm) per rev feed rate to obtain the typical surface finish. The insert can also be used for sleeve cuts when a square step is not required. For example, when used on an F80 or F5 machine it can be run at 1000 - 1200 RPM and .005/rev (.12 mm/rev) feed rate to remove up to .200" (5 mm) on the diameter from a 4.200" (106 mm) bore.

When cutting nodular, ductile, or compacted graphite cast iron the speed should be in the 200 - 400 SFPM area - 300 RPM on a 4" (100 mm) diameter bore. Nodular, ductile, or compacted graphite cast iron is found most often in high performance engine blocks or sleeves. When cutting these tuff cast irons it is best to use a feed rate of between .006" and .010" (.15 mm and .25 mm) per revolution.

6301E (High speed oversize through boring)

This is a square 3/8" (9.52 mm) IC, 1/32" (1.6 mm) radius, double sided, CBN Insert. These inserts are intended for use on high speed boring on Rottler F80 and F60 series machines. On common cast iron blocks the RPM should be set to achieve 1000 - 2200 SFPM On harder cast irons the RPM should be reduced to obtain acceptable tool life. A feed rate of .010" - .014" (.25 mm - .36 mm) per revolution. They have exceptional long life when removing up to .040" (1.02 mm) on the diameter. They do not give good tool life on some cast irons with high sulfur content.

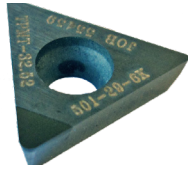
501-29-6K (High speed aluminum boring)

This is a 3/8" (9.52 mm) IC, triangle insert with a black diamond tip. It has a 1/32" (1.6 mm) radius. This insert is used to bore aluminum cylinders. It cannot be used to bore any other material. It is the best insert for finishing aluminum. For best tool life and finish the insert can be run from 400 – 4000 SFPM. Feed rates between .004" and .010" (.1 mm and .25 mm) should be used.

511-29-20E (Steel boring)

A 3/8" (9.52 mm) IC triangular insert with a gold coating and 1/32" (1.6 mm) cutting radius. This insert is for boring steel and ductile iron. It features a chip breaker to break-up the "string" of metal that can often form when boring steel.

SURFACING INSERTS

Rottler offers a wide variety of inserts used for surfacing. There are many applications in surfacing that include a variety of materials to be surfaced. Cylinder heads with pre-combustion chambers are particularly challenging because there are such a variety of materials used by the different cylinder head manufactures. One of the latest inserts we have tested for cutting cylinder heads with pre-combustion chambers is the 7202Z. It is probably the best for cutting a wide variety of heads with pre-combustion chambers. The 6303B is our standard for cutting a wide variety of cast iron heads. The 6303B will cut aluminum but is not ideal. The best insert for cutting aluminum is the 6303M which is a diamond insert.

When machining large cylinder blocks with larger precision depth counter bores using a 18" (450mm) or larger diameter fly cutter it is important to use a square 6301J insert. The smaller radius minimizes cutter deflection and will result in more accurate counterbore depths.

Below are the inserts commonly used on Rottler machines in surfacing/milling applications. Please read carefully..

6303B

A round 3/8" (9.52 mm) IC, double sided, CBN Insert. An excellent, long life insert for surfacing cast iron heads and blocks - round shape gives many cutting edges on each side of insert. When using a 14" (355.6 mm) cutterhead (SF, F65, F80) speeds range from 900-1200 RPM. When using an 18" (457 mm) cutterhead speeds range from 600-800 RPM.

6303M

A round 3/8" (9.52 mm) IC, single sided, PCD Insert. For use on aluminum only - heads and blocks without liners. This insert has a thin layer of PCD applied to a carbide disk. The diamond appears to be a shiny black wafer. The hardness of the diamond resists the abrasive nature of the silica in aluminum heads and blocks. RPM speeds with a 14" (355.6 mm) cutter range from 900-2000 RPM.

6303U

A round 3/8" (9.52 mm) IC, single sided, CBN Insert. This insert does an excellent job when cutting hard cast iron blocks and heads of a single material or bi-metal. This insert is the best to use when machining compacted graphite cast iron heads and blocks often found in the performance industry. RPM speeds with a 14" (355.6 mm) cutter range from 650-750 RPM.

6303K

A round, gold-colored, 3/8" (9.52 mm) IC, single sided, coated carbide insert. This is a very economical, general purpose insert for surfacing aluminum. It is advisable to use this insert for rough cutting to remove welding or contaminants before. A PCD insert should be used for the final cut to give the super fine finish required for MLS (multi layer steel) head gaskets. RPM speeds with a 14" (355.6 mm) cutterhead range from 600-1000 RPM.

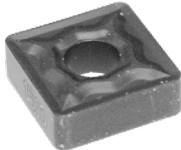
RS322

A square 3/8" (9.52 mm) IC carbide insert with a very dark purple ceramic coating. This carbide insert is normally used for high speed boring. It works well as an economical insert for rough surfacing or heavy stock removal of cast iron. A CBN insert should be used for the final finish cut.

6301J

A square 3/8" (9.52 mm) IC, 1/16" (.0039 mm) radius, double sided, CBN Insert. The 1/16" (.0039 mm) radius of this insert will produce a more accurate (flatter) finish than a round insert typically used for surfacing on F80/F90 Series machines when surfacing large diesel blocks and heads which are high in nickel. The square surfacing insert is intended for F80/F90 applications where it may encounter heavier cuts and greater interrupted cuts. When using an 18" (457 mm) cutter speeds range from 600-800 RPM, and with a 14" (355.6 mm) cutter speeds range from 900-1200 RPM.

6303V

An octagonal 3/8" (9.52 mm) IC, .094" (2.4 mm) corner radius, double sided, solid CBN Insert with 16 cutting corners. The .094" (2.4mm) corner radius of this insert will produce a more accurate (flatter) finish than a round 3/8" (.52mm) or square 1/16" (1.6mm) corner radius insert typically used for surfacing on F70/F80/F90/F100 Series machines when surfacing large diesel blocks and heads which are high in nickel. The octagonal surfacing insert is intended for applications where it may encounter interrupted cuts. When using an 18" (457 mm) cutterhead, speeds range from 600-800 RPM, and with a 14" (355.6 mm) cutter speeds range from 900-1200 RPM. The .094" (2.4mm) corner radius will allow faster feed rates compared to the 6301J square insert.

1/2" (12.70mm) SURFACING INSERTS**6303P**

A round 1/2" (12.7 mm) IC, single sided, PCD Insert. For use on aluminum only - heads and blocks without liners. This insert has a thin layer of PCD applied to the top of a carbide disk. The diamond appears to be a shiny black wafer. The hardness of the diamond resists the abrasive nature of the silica in aluminum heads and blocks. RPM speeds with a 14" (355.6 mm) cutter range from 1000-2000 RPM. Requires the purchase of 1/2" (12.7 mm) negative rake tool holders. The standard Rottler 3/8" (9.52 mm) IC tool holders will not hold this insert.

6303Q

A round 1/2" (12.7 mm) IC double sided, CBN Insert. An excellent insert for machining cast iron heads and blocks. Round shape gives many cutting edges on each side of insert. Requires the purchase of 1/2" (12.7 mm) negative rake tool holders. The standard Rottler 3/8" (9.52 mm) IC tool holders will not hold this insert.

6864E

A five sided / five cornered insert coated carbide insert. There are a total of ten cutting corners on this inserts. This is the best insert for roughing and finishing spray weld. This is used in Rottler milling heads that are designed specifically for cutting spray weld. Currently they cannot be used in Rottler's common "flycutter" style surfacing cutterheads.

Bi-metal Surfacing**Cylinder Heads with Pre-combustion Chambers and Aluminum Blocks with Hard Sleeves**

Cylinder heads with pre-combustion chambers or aluminum engine blocks with cast iron or steel cylinder sleeves are a challenge to cut and most often require a special cutting insert and special cutting technique. There are many different material combinations so there is not one insert that works the best on all applications. Below is information to use as a guide to the best insert to use and some of the required cutting parameters.

Generally the tool life when using any of these inserts in the cutting of bi-metal surfaces will be short when compared to cutting a single material. The cost of the insert per surfacing job will be higher compared with cutting single materials. The customer must incorporate the higher insert cost into the price charged for the surfacing job.

Another excellent alternative to cutting cylinder heads with pre-combustion chambers is to remove the combustion chamber from the head, surface the cylinder head, then use the Rottler Pre-combustion Chamber Re-seating Tool to machine the combustion chamber counterbore back to OEM specification depth. It is fast and economical to use. See Bulletin C49.

Cylinder Heads with Protruding Valve Seats

Some cylinder heads have valve seats that protrude into the head gasket surface. Valve seats are made out of a wide variety of material. Some are very hard or difficult to cut when compared with the aluminum or cast iron head surface. In many cases it is best to cut the valve seat down below the head surface in a seat and guide machine. This takes a few more minutes when cutting the valve seats but it can save a lot of time and minimize tooling cost when surfacing the head.

The following inserts use Rottler 3/8" (9.52mm) Toolholders supplied with Rottler Surfacing Cutterheads;

6303S

A round 3/8" (9.52 mm) IC, single sided, CBN Insert. For use on aluminum blocks with iron liners and aluminum heads with steel pre-combustion chambers. RPM speeds with a 14" (355.6 mm) cutter range from 650-750 RPM.

6303U

A round 3/8" (9.52 mm) IC, single sided, CBN Insert. This insert does an excellent job when cutting hard cast iron blocks and heads of a single material or bi-metal. This insert is the best to use when machining compacted graphite cast iron heads and blocks often found in the performance industry. RPM speeds with a 14" (355.6 mm) cutter range from 650-750 RPM.

6303R

A round 3/8" (9.52 mm) IC, single sided, CBN Insert. For use on cast iron heads with steel pre-combustion chambers. RPM speed with a 14" (355.6 mm) cutter range from 600-700 RPM and with an 18" (457 mm) cutter range from 500-600 RPM.

6301I

A square 3/8" (9.52 mm) IC, double sided, ceramic insert. For use on cast iron heads with pre-combustion chambers. You can make one finish cut and two rough cuts with each new cutting edge. Always use a new edge when making a finish cut. Use 350-500 RPM on a 14" (355.6 mm) diameter cutterhead.

6301V

A round 3/8" (9.52 mm) IC, double sided, ceramic insert. For use on cast iron heads with pre-combustion chambers. You can make one finish cut and two rough cuts with each new cutting edge. Always use a new edge when making a finish cut. Use 350-500 RPM on a 14" (355.6 mm) diameter cutterhead.

SPECIAL TOOLHOLDER AND INSERT FOR SURFACING DIESEL ALUMINUM HEADS WITH STEEL PRE-CHAMBERS

7202X

Fly Cutter Tool Holder Assembly uses special 7202Z insert for surfacing aluminum cylinder heads with steel pre-combustion chambers.

7202Z

Round Insert, 3/8" (9.52 mm) IC gold coated for aluminum cylinder heads with steel pre-combustion chamber. For use with 7202X tool holder only. RPM speeds with 14" (355.6 mm) cutter range from 450-550 RPM and with a 16" (406.4 mm) cutter, 400-500 RPM. Requires very slow feed rate. Surfacing these heads is a difficult operation and only the minimum amount of material can be removed per pass. For best results, rotating the insert so that a new 'corner' is used for the final pass should give good results.

INSERTS FOR SHELL MILLING CUTTERHEADS

6514T

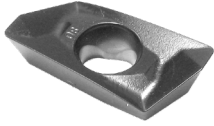

Parallelogram configuration, carbide material. Special insert used with the Rottler 650-2-44P 4" (101.6 mm) shell mills only. Designed for general purpose applications.

MAIN LINE BORING INSERTS

Use the same RT series inserts as defined under cylinder boring. Depending on type of toolholder, either 1/4" (6.35 mm) IC or 3/8" (9.52 mm) IC inserts will be required. Commonly 1/64" (.8 mm) radius inserts are used for rough or heavy cutting, and 1/32" (.4 mm) radius inserts are used for finish boring for a smooth surface finish. In extreme conditions where the material is hard or the tool is extended and prone to chatter, use the 1/64" (.8 mm) inserts.

CONNECTING ROD INSERTS

Many customers have reported good results boring connecting rods with Rottler RT inserts. When boring small end bearings made of bronze, the RTF series of inserts should be used.

Machine Parts

F69ATC Front View



F69ATC Top View

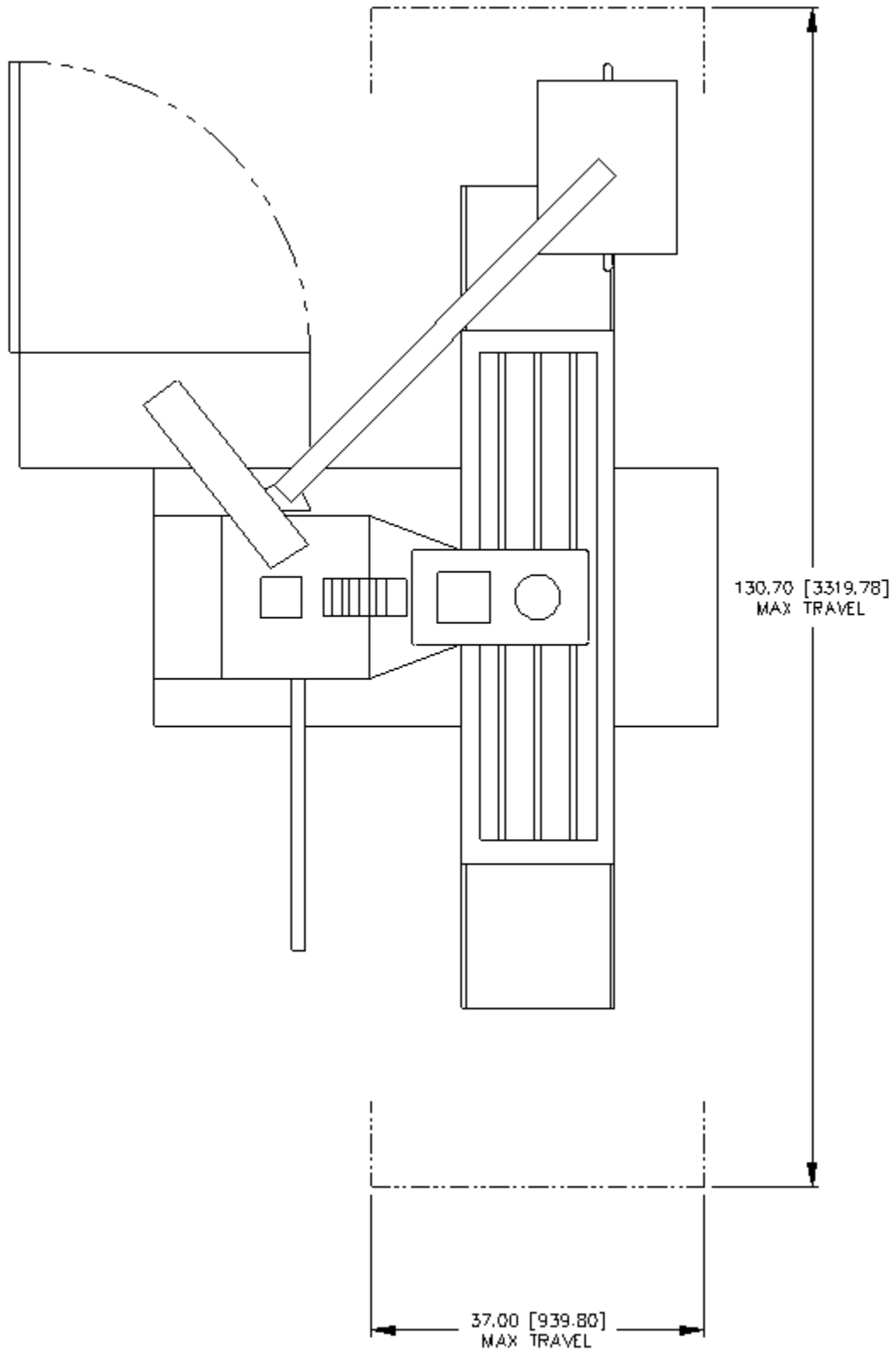

Electrical Panel

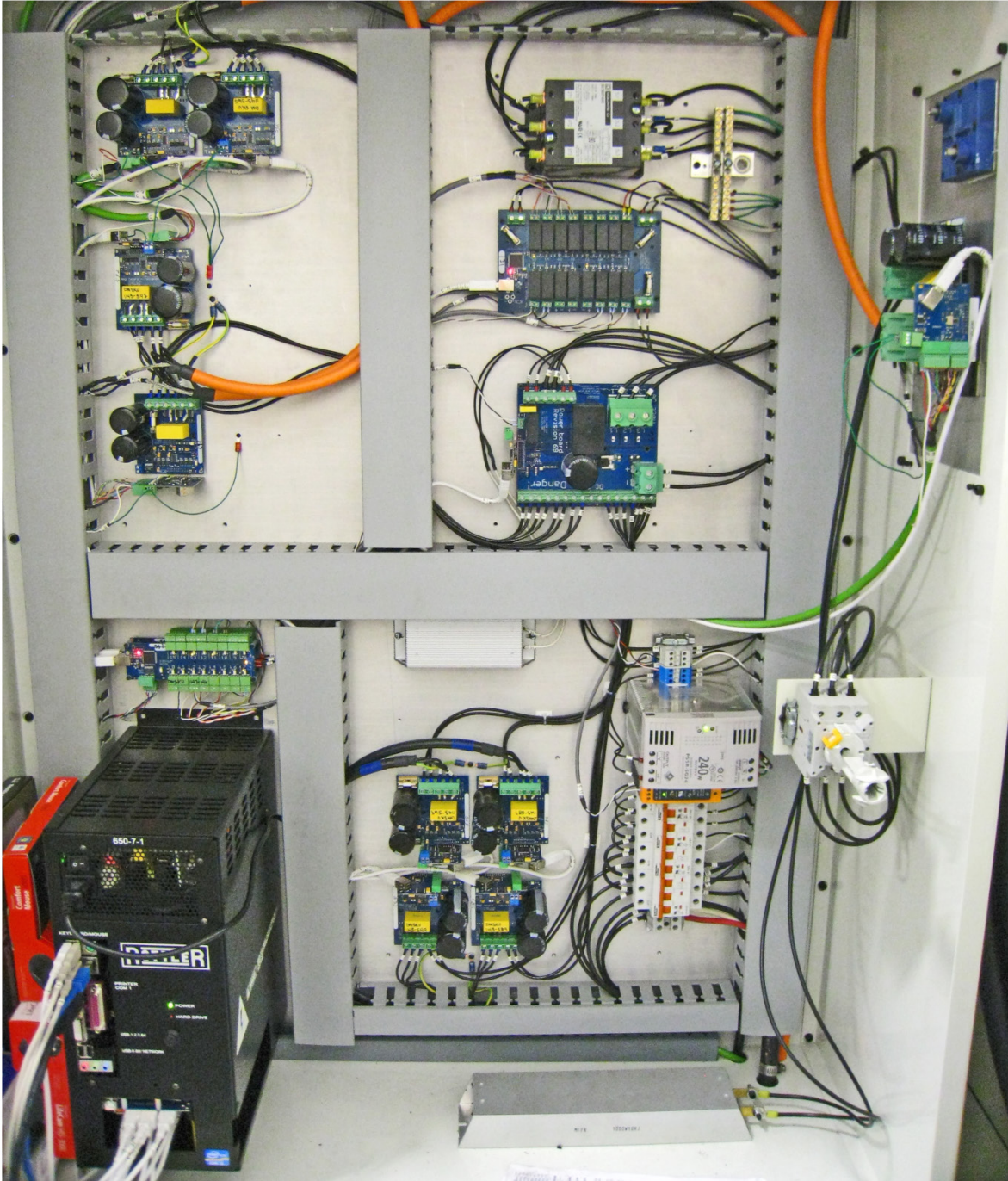

Computer 650-7-1

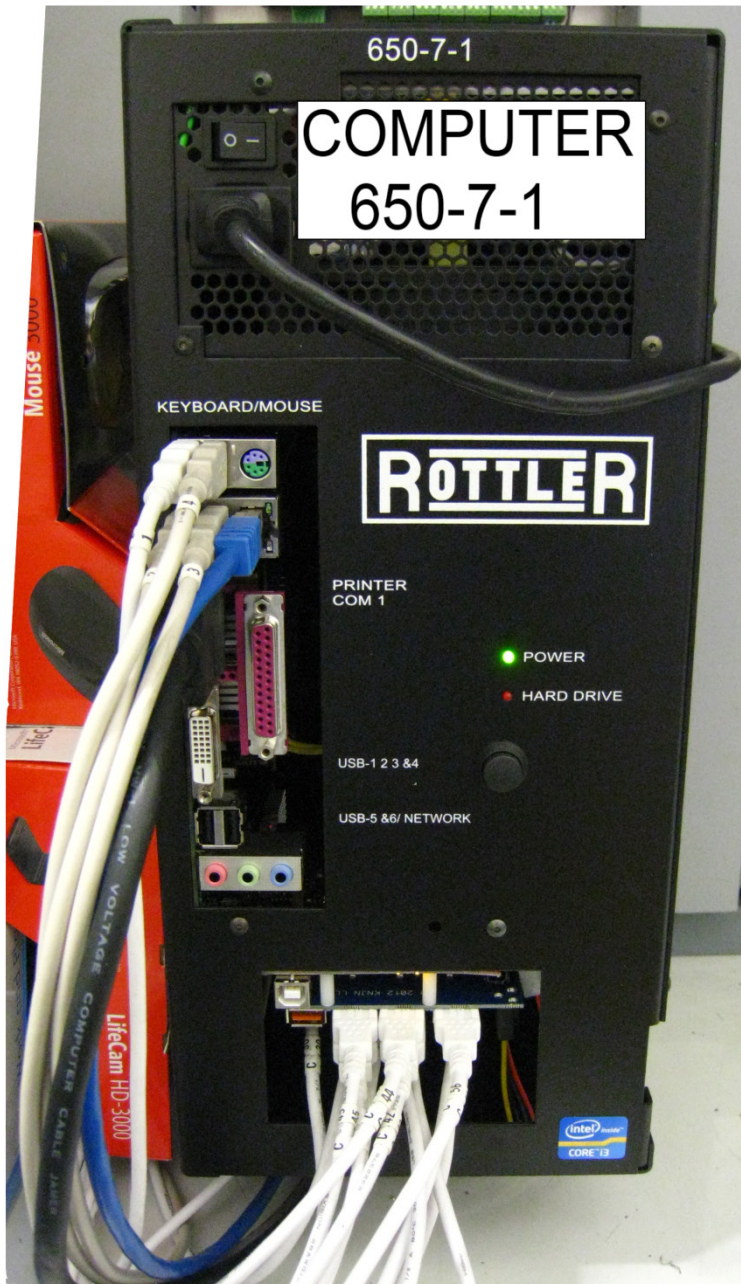

Computer Components

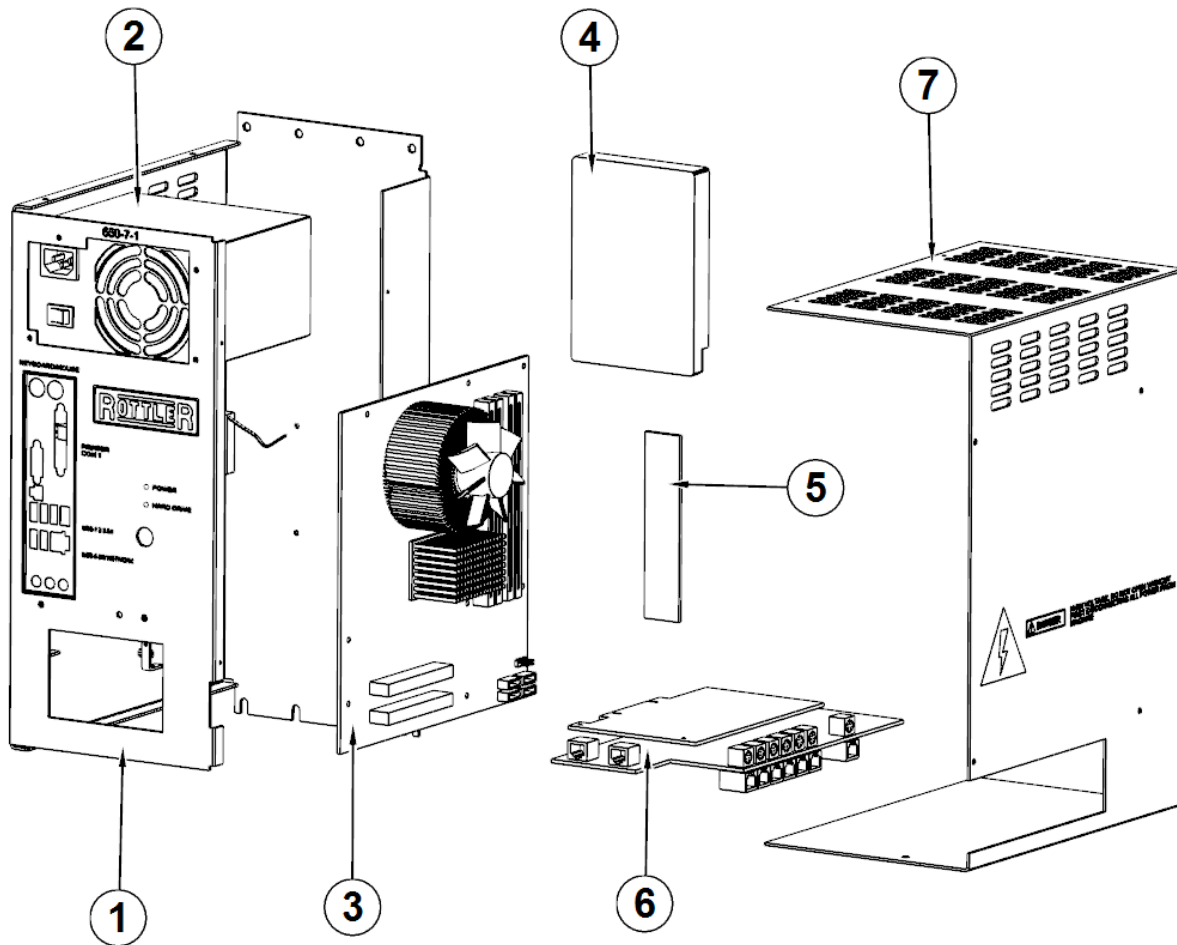

ITEM	PART #	DESCRIPTION
1	650-1-27Y	FRAME,COMPUTER CASE--SOLD IN ASSY #650-1-27X
2	650-7-1C	400W POWER SUPPLY
3	650-7-1A	MOTHER BOARD
4	650-7-1F	HARD DRIVE
5	650-7-2F	8GB DDR4 RAM
6	9035D	PCI E CARD - 16 LINK
7	650-1-27Z	COVER,COMPUTER CASE-SOLD IN ASSY #650-1-27X

Accessory Amps

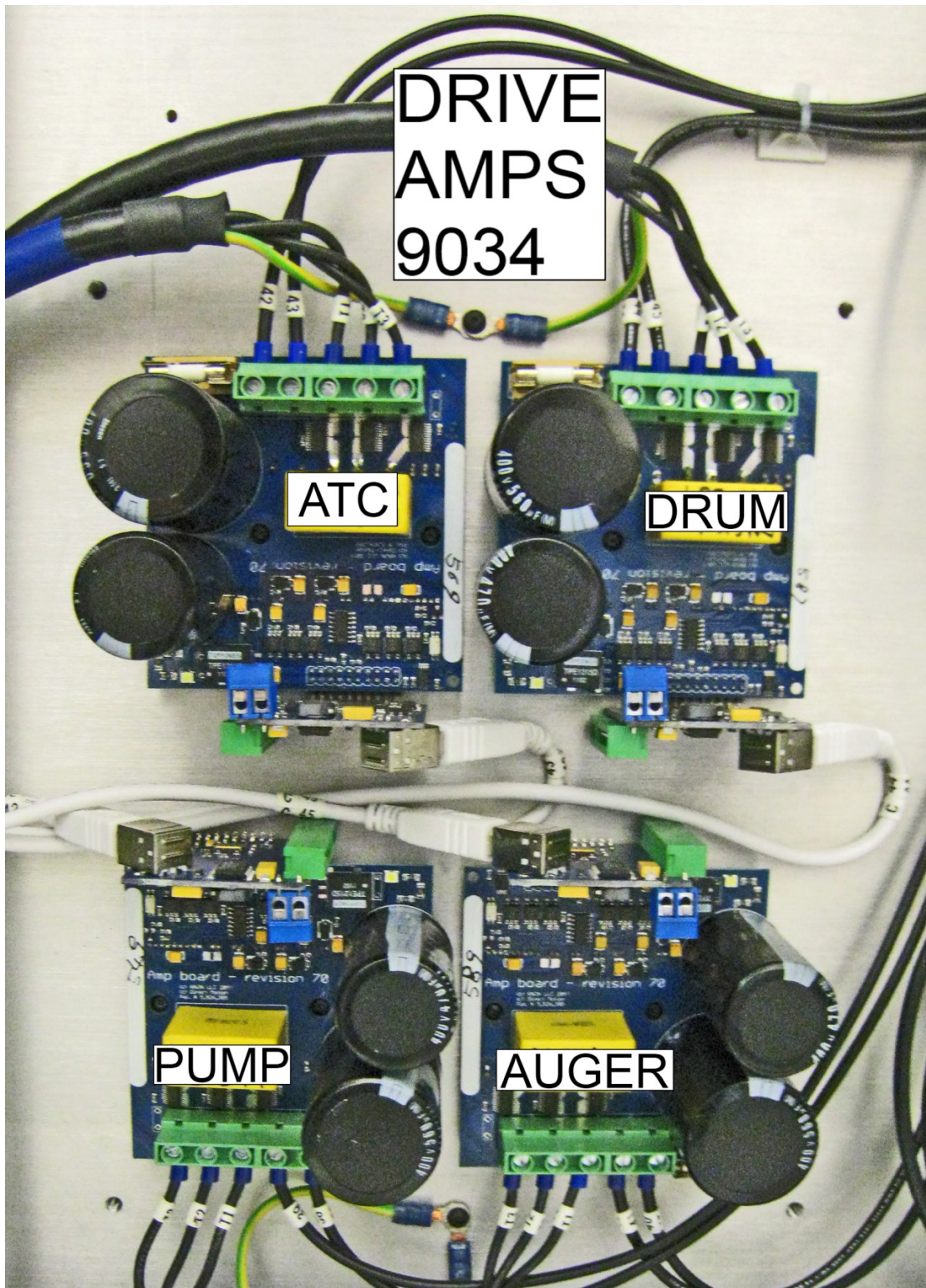

Axis Amps

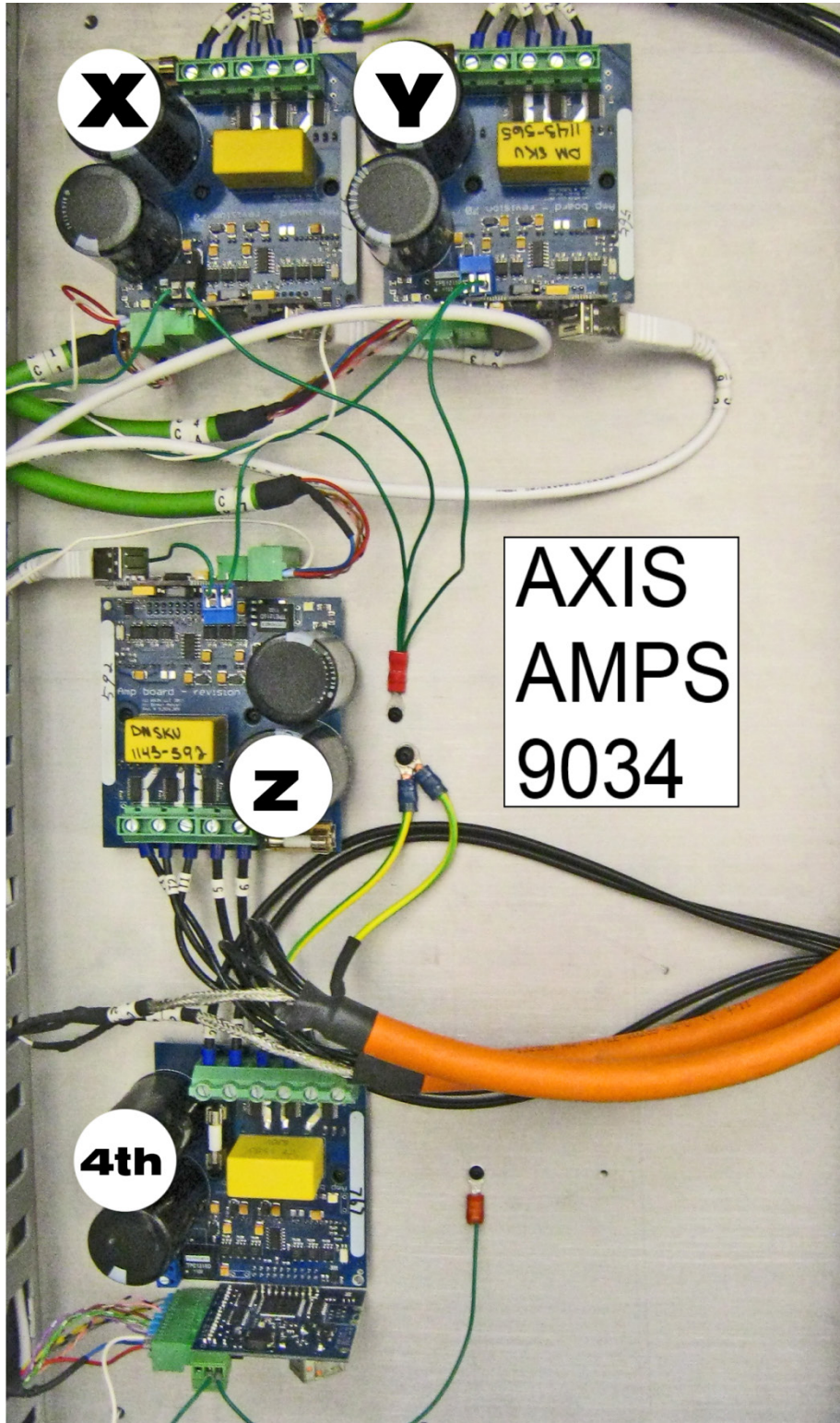

Contactor, Output Board, LG Power Board

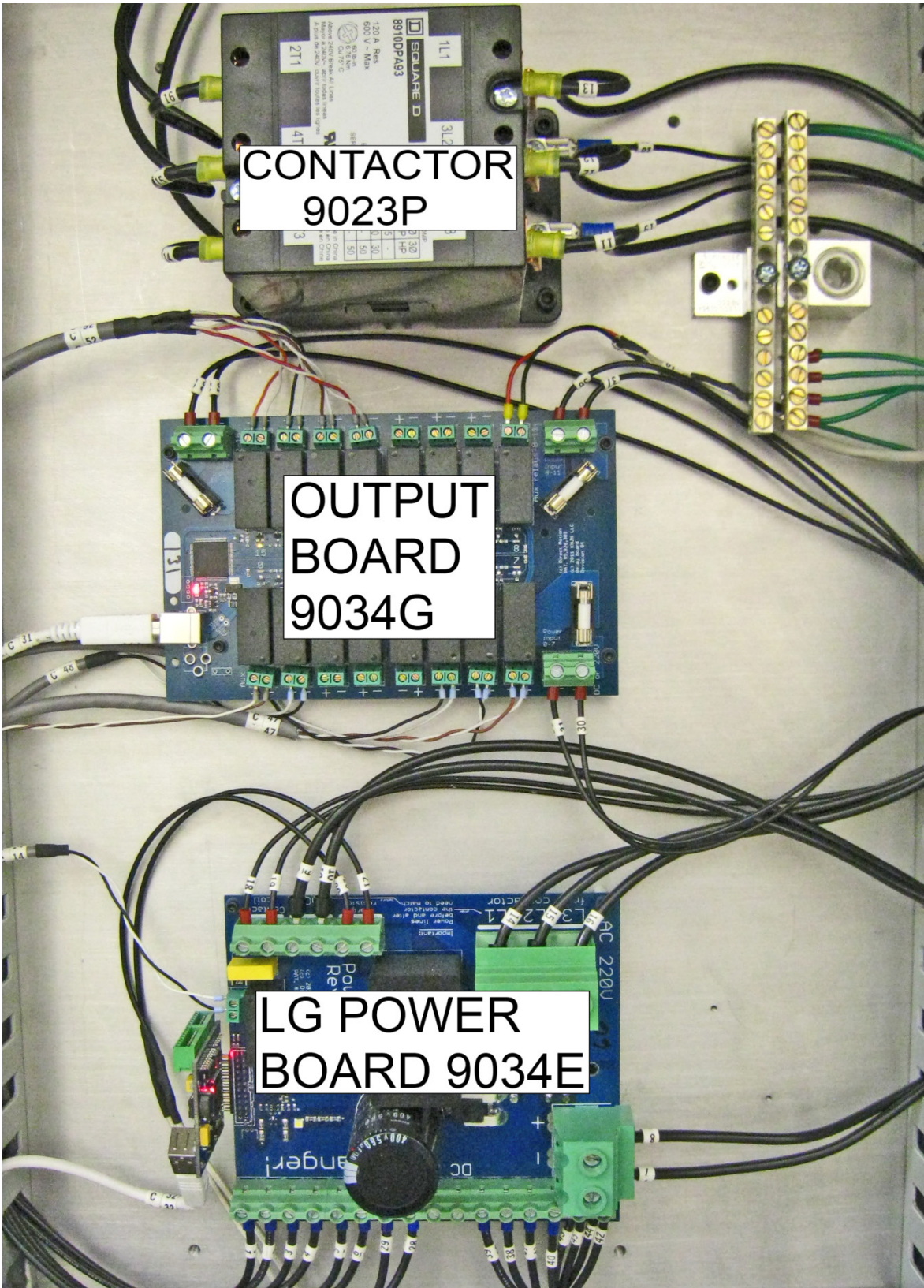

Input Boards

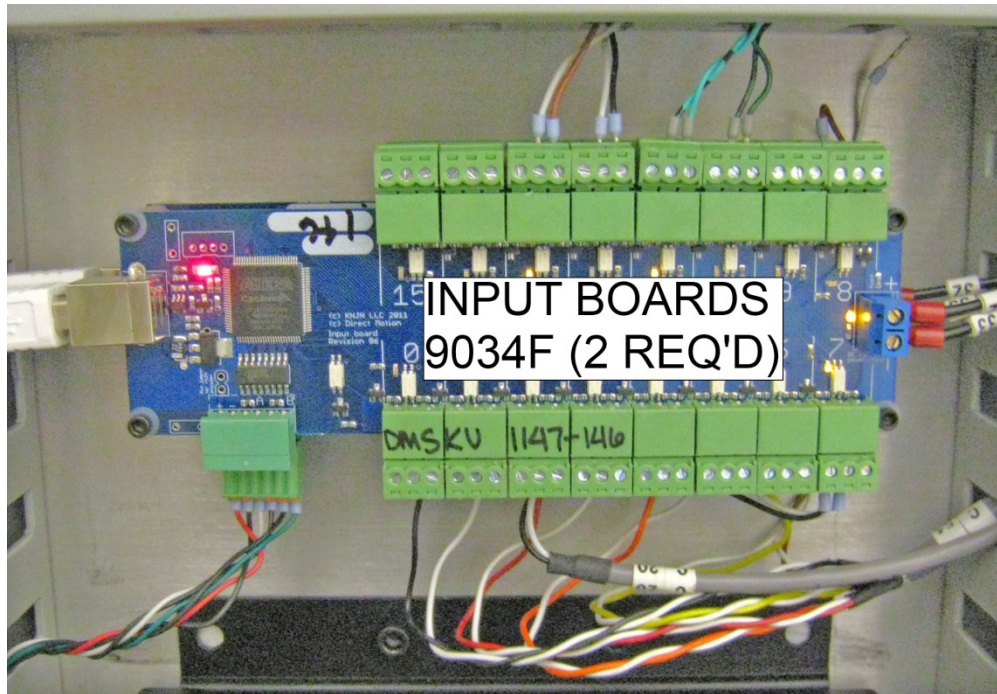

Power Switch

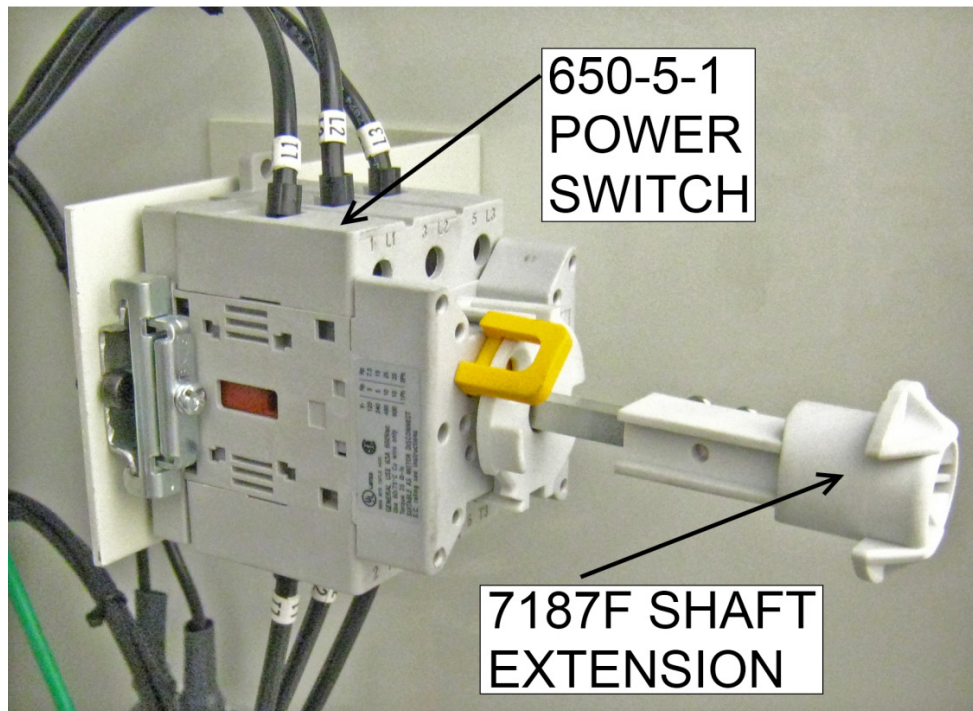

Spindle Amp

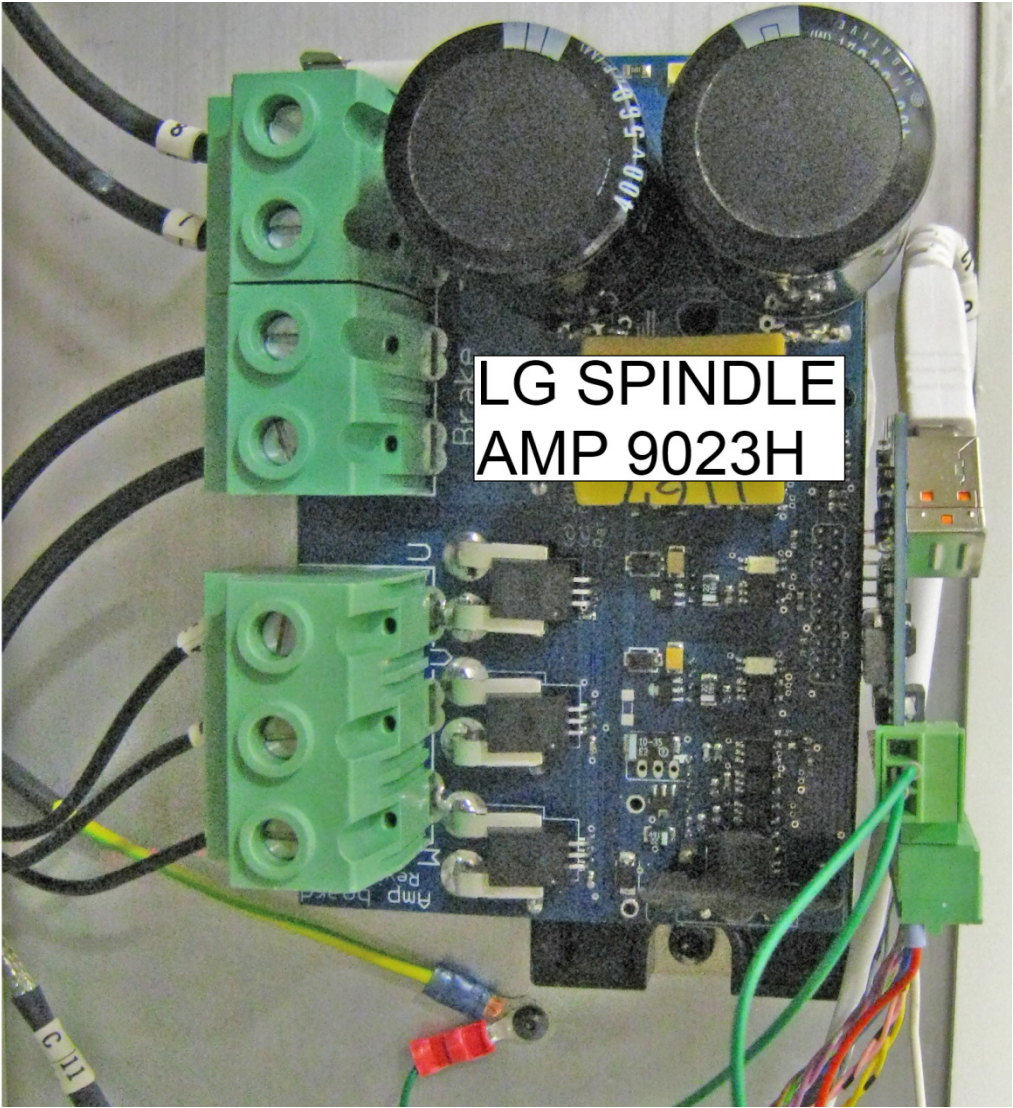

DIN Rail Components

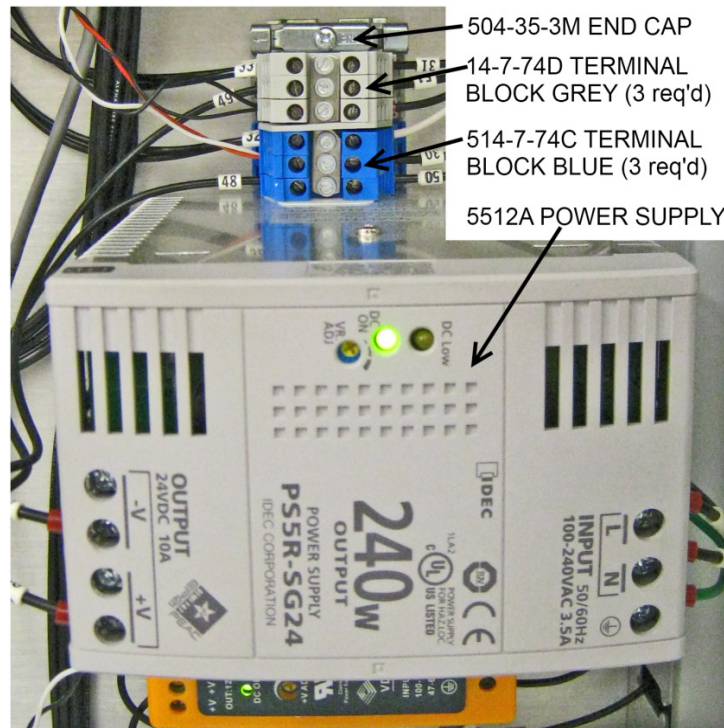

- 504-35-3M END CAP
- 14-7-74D TERMINAL BLOCK GREY (3 req'd)
- 514-7-74C TERMINAL BLOCK BLUE (3 req'd)
- 5512A POWER SUPPLY

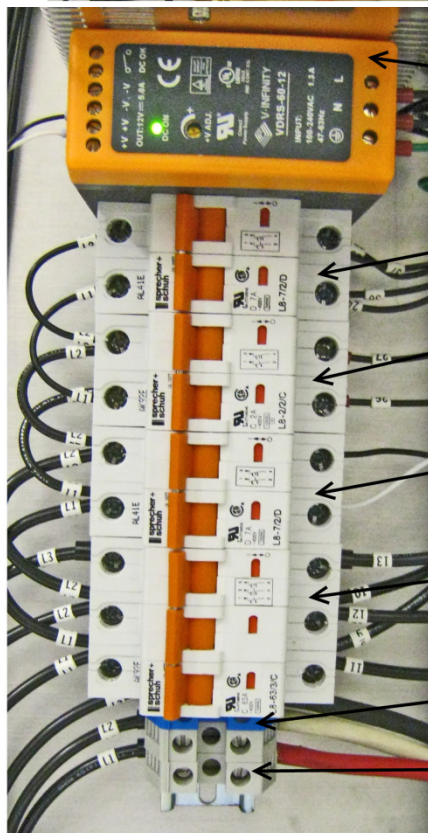

- 9038C POWER SUPPLY
- 504-35-3U 7 AMP BREAKER
- 504-35-3 2 AMP BREAKER
- 504-35-3U 7 AMP BREAKER
- 64623 63 AMP BREAKER
- 514-7-74C TERMINAL BLOCK BLUE
- 514-7-74D TERMINAL BLOCK GREY (2 req'd)

Chip Shield Assembly

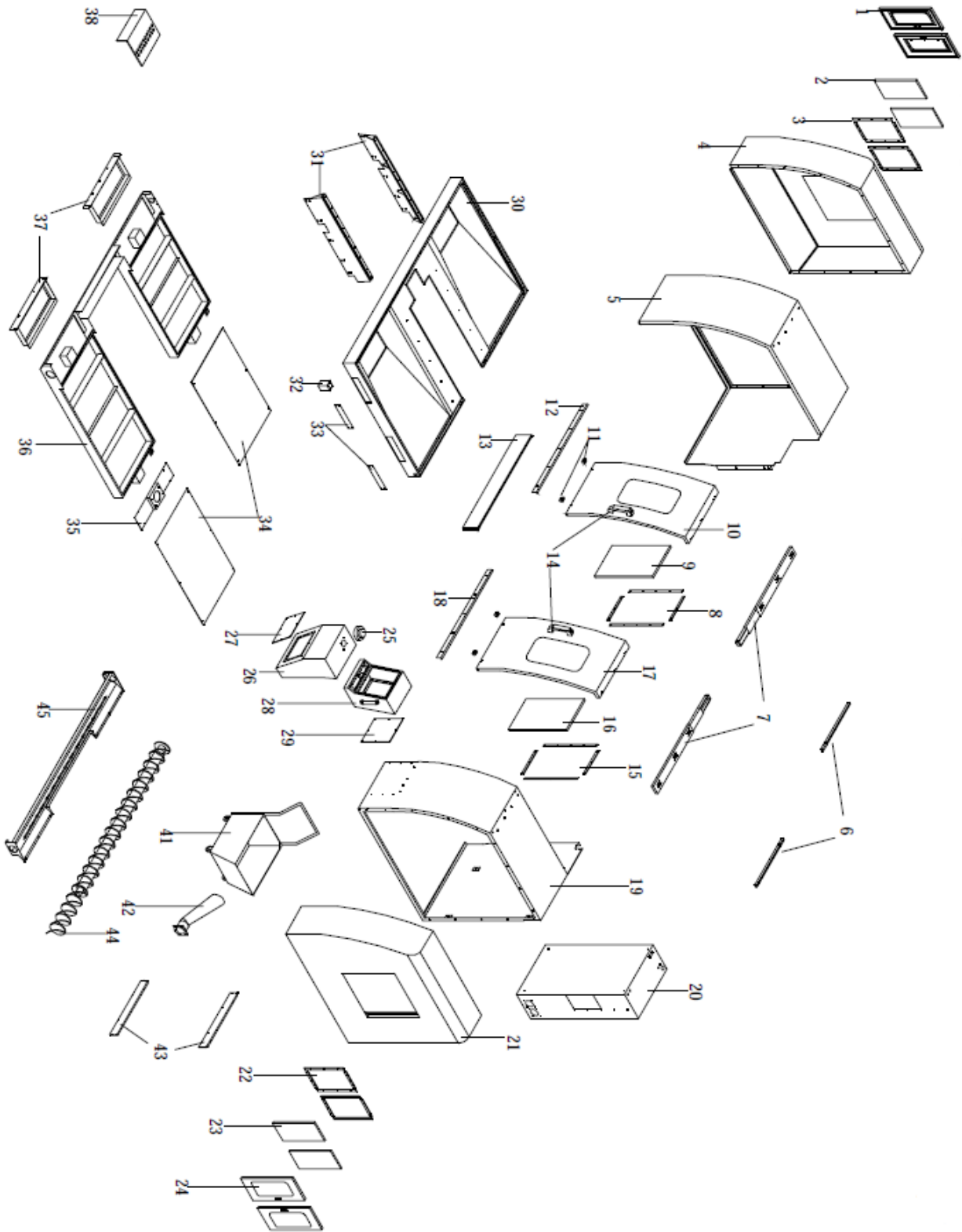

Chip Shield Parts

ITEM	PART	Description	Q'TY	ITEM	PART	Description	Q'TY
01	D10-K001	Left window	1	35	D10-K035	Pump plate	1
02	D10-K002	Sight glass	1	36	D10-K036	Coolant tank	1
03	D10-K003	Sight glass cover	1	37	D10-K037	Chip drawer	2
04	D10-K004	Left end cover	1	38	D10-K038	Filter	1
05	D10-K005	Left sheet metal	1	41	D10-K041	Chip bucket	1
06	D10-K006	Upper fix plate	2	42	D10-K042	Pipe	1
07	D10-K007	Upper slide rail	2	43	D10-K043	Plate	2
08	D10-K008	Sight glass cover	1	44	D10-K044	Chip auger	1
09	D10-K009	Sight glass	1	45	D10-K045	Chip trough	1
10	D10-K010	Left slide door	1				
11	D10-K011	Roller	4				
12	D10-K012	Left rail way	1				
13	D10-K013	Front sheet metal	1				
14	D10-K014	Handle	3				
15	D10-K015	Sight glass cover	1				
16	D10-K016	Sight glass	1				
17	D10-K017	Right slide door	1				
18	D10-K018	Right rail way	1				
19	D10-K019	Right sheet metal	1				
20	D10-K020	Electric cabinet	1				
21	D10-K021	Right end cover	1				
22	D10-K022	Sight glass cover	1				
23	D10-K023	Sight glass	1				
24	D10-K024	Right window	1				
25	D10-K025	Rotor	1				
26	D10-K026	Monitor bracket	1				
27	D10-K027	Cover	1				
28	D10-K028	Monitor box	1				
29	D10-K029	Cover	1				
30	D10-K030	Chip pan	1				
31	D10-K031	Support	2				
32	D10-K032	Foot	4				
33	D10-K033	Side cover	2				
34	D10-K034	Coolant tank cover	2				

Base

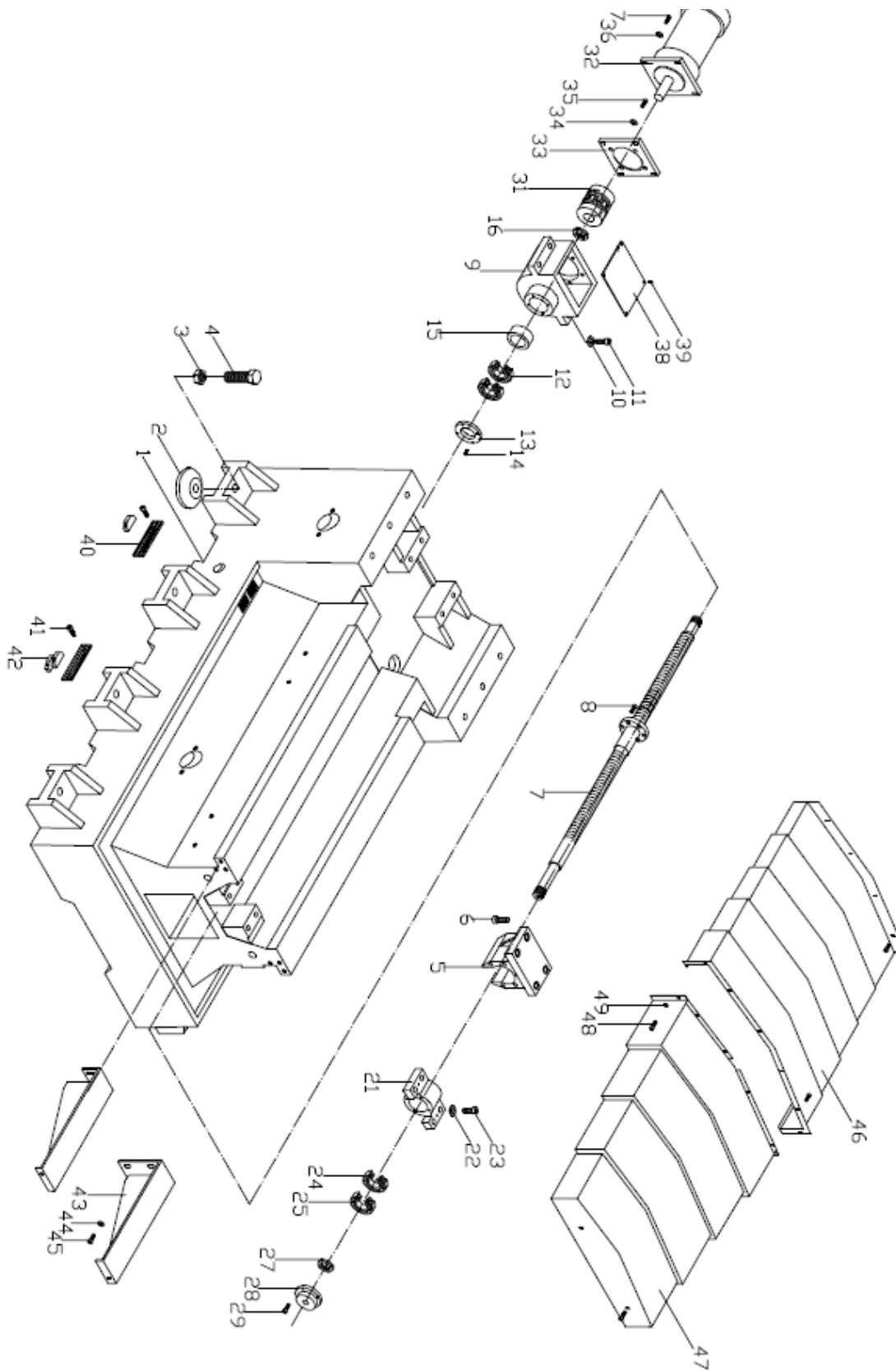

Base Parts

ITEM	PART	Description	Q'TY	ITEM	PART	Description	Q'TY
1		Base	1	40		Seat	2
2		Leveling pad	8	41		Screw (M6*12)	4
3		Nut	8	42		Dog	3
4		Screw (M24*70)	8	43		Cover Brace	2
5		Nut Bracket	1	44		Washer (M6)	6
6		Screw(M12*40)	4	45		Screw (M6*20)	6
7	650-6-6A	Ballscrew	1	46		Rear Way Cover	1
8		Screw (M10*25)	5	47		Front Way Cover	1
9		Bearing Bracket	1	48		Screw (M6*12)	18
10		Washer (M12)	4	49		Washer (M6)	18
11		Screw (M12*60)	4				
12		Bearing (25T AC62B)	2				
13		Bearing Cover	1				
14		Screw (M6*20)	4				
15		Spacer	1				
16		Nut (YSF M25*1.5P)	1				
21		Bearing Bracket	1				
22		Washer (M12)	4				
23		Screw (M12*70)	4				
24		Bearing (6305)	1				
25		Bearing (25T AC62B)	1				
27		Nut(YSF M25*1.5P)	1				
28		Cover	1				
29		Screw(M6*12)	4				
31	650-6-6	Coupling	1				
32		Motor	1				
33		Motor Plate	1				
34		Washer (M10)	4				
35		Screw (M10*35)	4				
36		Washer (M10)	4				
37		Screw (M10*35)	4				
38		Cover	1				
39		Screw (M5*8)	4				

Column and Head

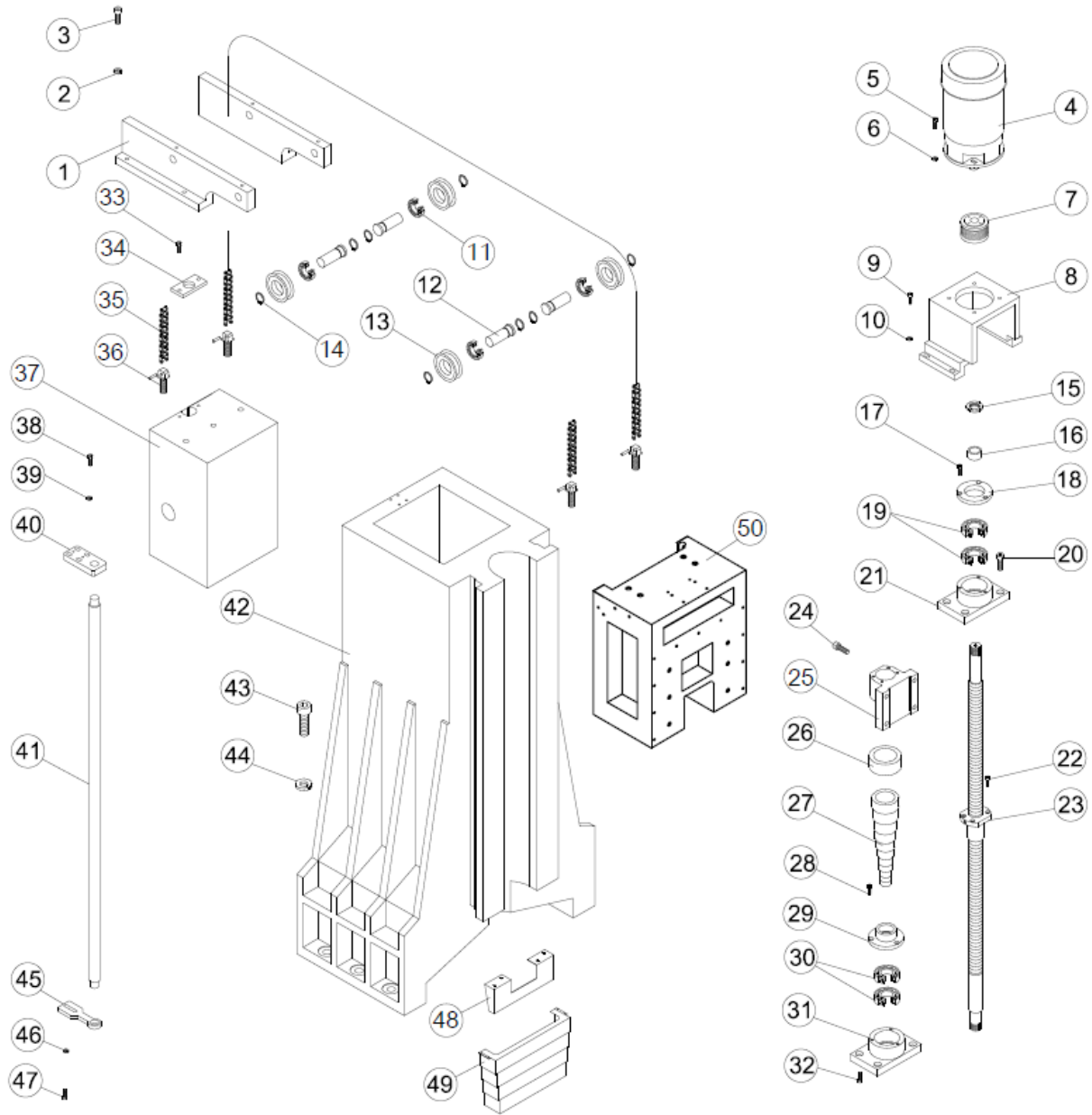

Column and Head Parts

ITEM	DESCRIPTION	Q'TY	ITEM	DESCRIPTION	Q'TY	ITEM	DESCRIPTION	Q'TY
①	Chain Supporter	2	⑬	Wheel	4	⑳	Nut Bracket	1
②	Washer	4	⑭	C-Ring	8	㉑	Upper Stay	1
③	Screw (M8)	4	⑮	Nut	1	㉒	Ballscrew Chip Cover	1
④	Motor	1	⑯	Spacer	1	㉓	Screw (M6)	3
⑤	Screw	4	⑰	Screw (M6*20)	3	㉔	Lower stay	1
⑥	Washer	4	⑱	Bearing Cover	1	㉕	Bearing (#6025)	2
⑦	Coupling 650-6-7	1	㉚	Bearing (#7025)	2	㉖	Bearing Bracket	1
⑧	Motor seat	1	㉛	Screw (M10*35)	4	㉗	Screw (M10*35)	4
⑨	Screw (M8)	4	㉜	Bearing Bracket	1	㉘	Screw (M8)	4
⑩	Washer	4	㉝	Screw (M10*25)	4	㉙	Buffer pad	1
⑪	Bearing (#6025)	4	㉞	Ballscrew 650-6-7A	1	㉚	Chain	2
⑫	Shaft	4	㉟	Screw (M12*40)	4	㉛	Screw (M16)	2
ITEM	DESCRIPTION	Q'TY	ITEM	DESCRIPTION	Q'TY			
㉟	Count Balance	1	㉞	Cover	1			
㊱	Screw (M8)	4	㊲	Headstock	1			
㊳	Washer	4	㊳					
㊴	Guide pad	1	㊴					
㊵	Guide shaft	1	㊵					
㊶	Frame	1	㊶					
㊷	Screw (M24)	6	㊷					
㊸	Washer	6	㊸					
㊹	Guide pad	1	㊹					
㊺	Washer	2	㊺					
㊻	Screw (M8)	2	㊻					
㊼	Cover brace	1	㊼					

Table and Bed

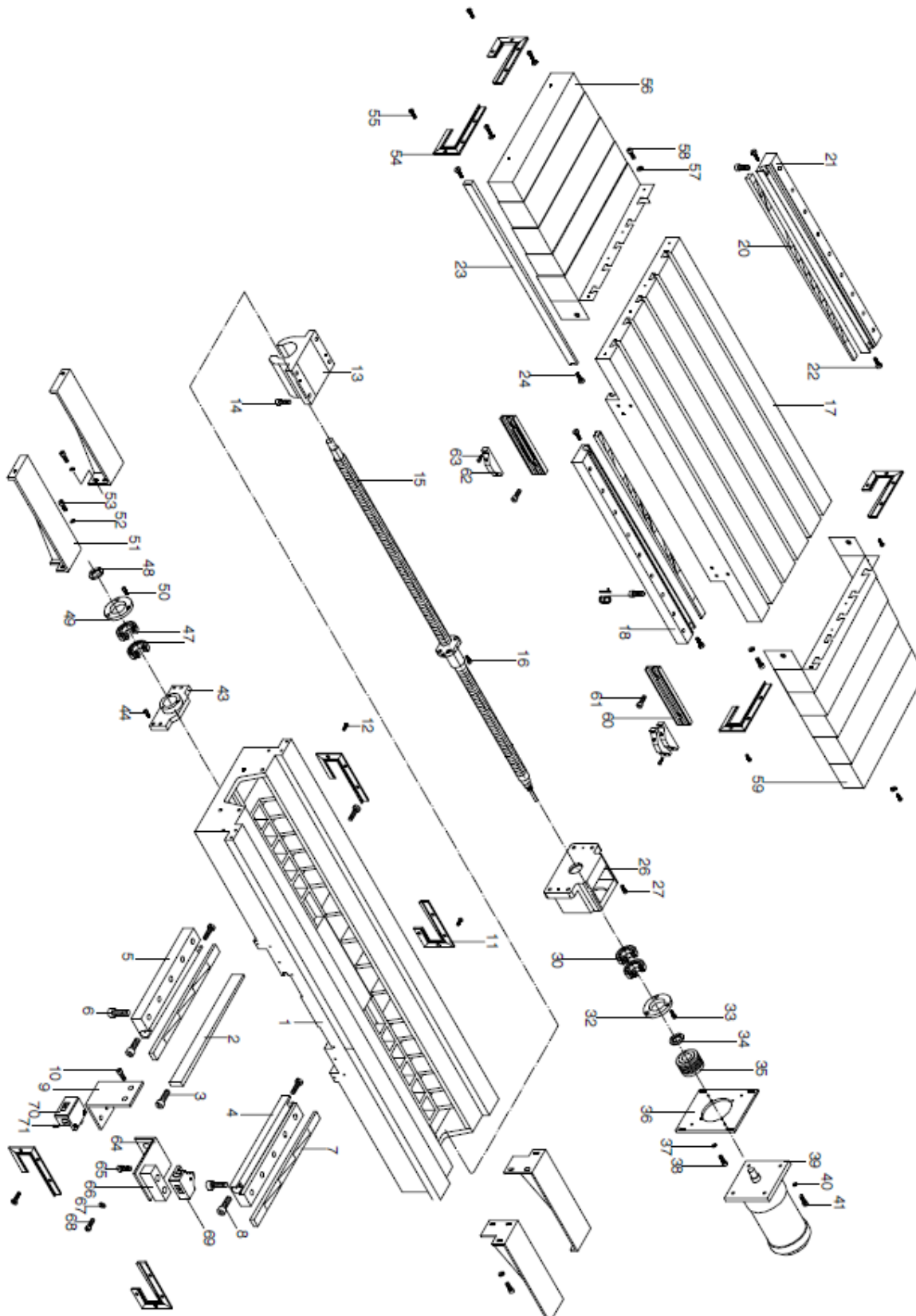
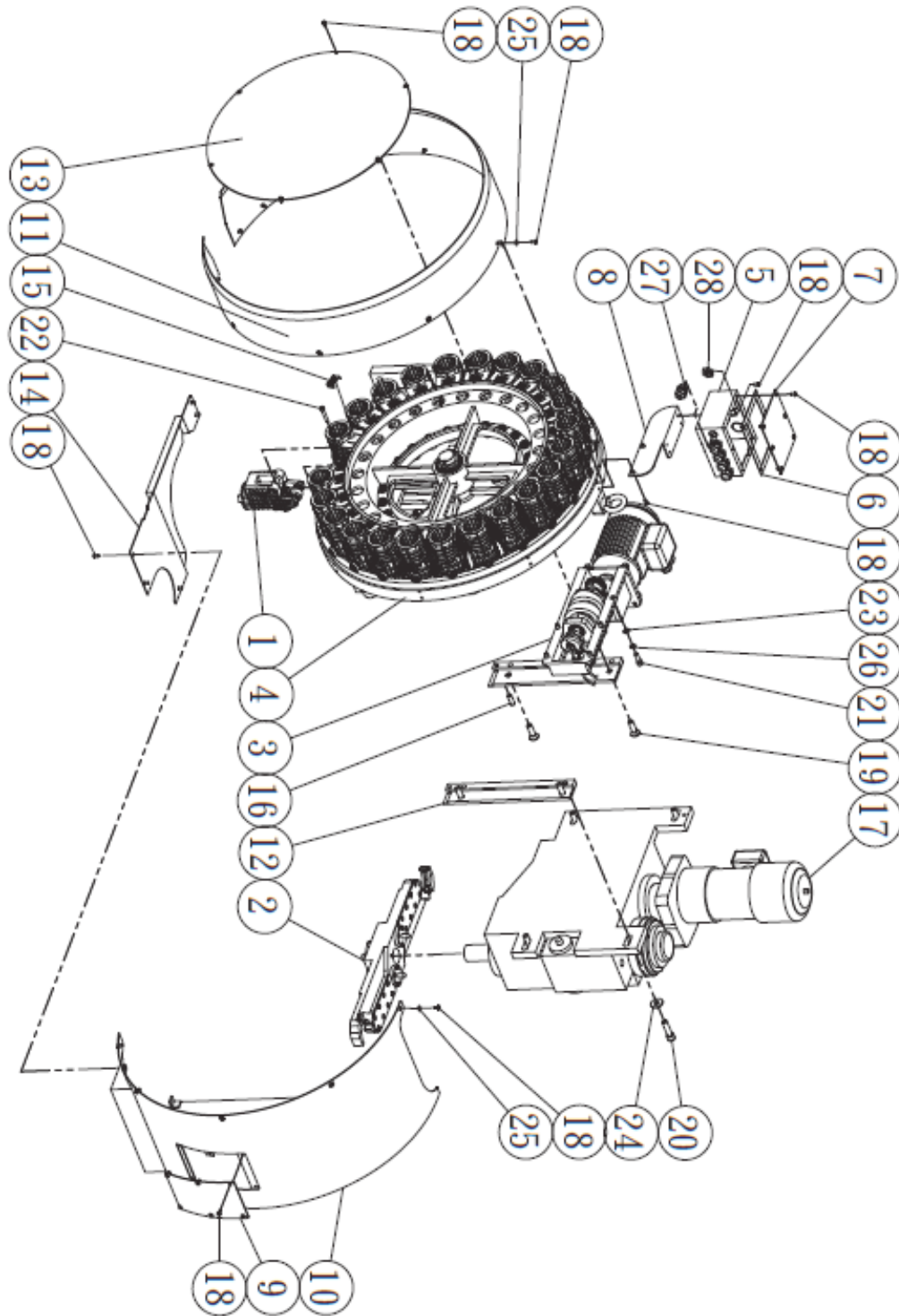

Table and Bed Parts

ITEM	PART	Description	O'TY	ITEM	PART	Description	O'TY
1		Saddle	1	44		Screw (M8*30)	4
2		Gib	1	47		Bearing(6205)	2
3		Gib Screw(5/16''*30)	2	48		Nut(YSR M25*1.5P)	1
4		Bracket	1	49		Cover	1
5		Bracket	1	50		Screw (M6*12)	4
6		Screw (M12*40)	10	51		Cover Brace	4
7		Gib	2	52		Washer (M6)	12
8		Gib Screw (5/16''*30)	4	53		Screw (M6*20)	12
9		Seat	1	54		Wiper	4
10		Screw (6*16)	2	55		Screw (M5*12)	16
11		Wiper	4	56		Left Way Cover	1
12		Screw(M5*12)	16	57		Washer (M6)	4
13		Nut Bracket	1	58		Screw (M6*12)	12
14		Screw (M12*40)	4	59		Right Way Cover	1
15	650-9-5A	Ballscrew	1	60		Seat	2
16		Screw (M10*25)	5	61		Screw(M6*16)	4
17		Table	1	62		Dog	3
18		Bracket	1	63		Screw(M5-12)	6
19		Screw (M12*40)	18	64		Seat	1
20		Gib	2	65		Screw(M6*16)	2
21		Bracket	1	66		Block	1
22		Gib Screw (5/16''*30)	4	67		Washer (M6)	2
23		Gib	1	68		Screw (M6*16)	2
24		Gib Screw (5/16''*30)	2	69		X Limit Switch	1
26		Bearing Bracket	1	70		Y Limit Switch	1
27		Screw (M10*45)	4	71		Screw(M6*20)	2
30		Bearing(25T AC62)	2				
32		Bearing Cover	1				
33		Screw (M6*20)	3				
34		Nut(YSF M25*1.5P)	1				
35	650-6-5	Coupling	1				
36		Motor Plate	1				
37		Washer (M10)	4				
38		Screw(M10*35)	4				
39		Motor	1				
40		Washer (M10)	4				
41		Screw(M10*35)	4				
43		Bearing Bracket	1				

Tool Changer Parts

Tool Magazine



TOOL MAGAZINE PARTS LIST			
ITEM	PART NUMBER	DESCRIPTION	QTY
1	DA01 BT(DIN, ISO)6001	Tool pocket element	24
	DA01 BT(DIN,ISO)9001	90 degree tool pocket element	24
	DA02 HAKA63	90 degree tool pocket element	24
2	CH.1.3.4	Arm Component	1
3	CH.1.3.5	Driving Component	1
4	CH.1.3.6	Model Component	1
5	DE0102604	Wire Box	1
6	DE0104302	Box Pad	1
7	DE0102703	Wire Box Cap	1
8	DE0102801	Wire Box Mount	1
9	DD0100502	Acrylic Faceplate	1
	DD0100501	Acrylic Faceplate	1
10	DD0101201	Camshaft Cover	1
	DD0100605	Camshaft Cover	1
	DD0104201	Camshaft Cover	1
	DD0104101	Camshaft Cover	1
	DD0104703	Camshaft Cover	1
	DD0104901	Camshaft Cover	1
11	DE0103104	Round Cover	1
	DD0102703	Cover-Left	1
	DD0102803	Cover-Right	1
	DD0104301	Cover-Right	1
	DD0104401	Cover-Left	1
	DD0103001	Acrylic Cover Pellucid	1
	DD0103901	Acrylic Cover-Brown	1
	DD0104501	Acrylic Cover-Opening	1
12	DE0104101	Shim	2
	DE0104001	Shim	2
	DE0104601	Shim	2
	DE0104801	Shim	2
	DE0104701	Shim	2

ITEM	PART NUMBER	DESCRIPTION	QTY
12	DE0105101	Shim	2
13	DD0100101	Tool Disk Cap	1
14	DD0102003	Cam Plate	1
	DD0100807	Cam Plate	1
	DD0103801	Cam Plate	1
	DD0104101	Cam Plate	1
	DD0104802	Cam Plate	1
15	DA0100401	Number Card	24
16	PIN0830	Pin	2
17	A402	Tool Changing Cam	1
	A402	DEX Cam	1
18	MR05080010	Round Bolt	44
19	MB12125040	Round Socket Bolt	4
20	MI1217545	Socket Bolt	4
	MI1217540	Socket Bolt	4
	MI1217550	Socket Bolt	4
21	MI08125025	Socket Bolt	5
22	MI0610040	Socket Bolt	24
23	W08	Washer	5
24	W12S	Washer	4
25	W05	Washer	18
26	WS08	Spring Washer	5
27		Cable Fixed Nut	5
28		Cable Fixed	5

Arm Components

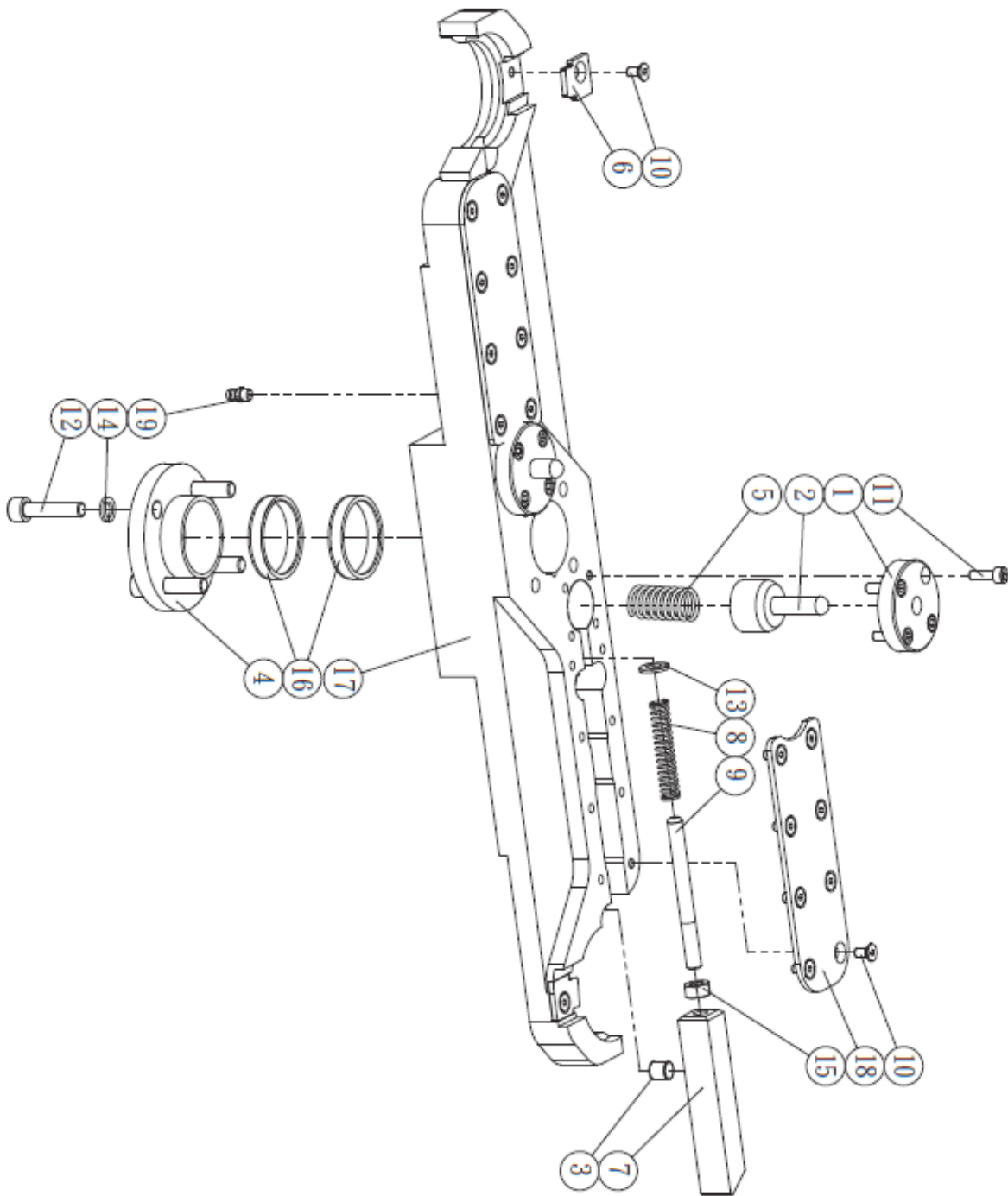

ARM PARTS LIST			
ITEM	PART NUMBER	DESCRIPTION	QTY
1	DB0100202	Braking Pin Cover	2
2	DB0100302	Braking Pin	2
3	DB0100502	Position Pin	2
4	DB0100602	Cap	1
5	DB0100701	Braking Pin Spring	2
6	DB0100901	Position Key	2
7	DB0101401	Terminal Block	2
	DB0200501	Stop Sliding Block	2
	DB0300501	Stop Sliding Block	2
	DB0600502	Stop Sliding Block	2
	DB0700401	Stop Sliding Block	2
8	DB0200109	500BT Tool arm	1
	DB0200202	500CAT Tool arm	1
	DB0200601	500BT80 Tool arm	1
	DB0300103	530BT Tool arm	1
	DB0300603	530CAT Tool arm	1
	DB0600101	620BT Tool arm	1
	DB0700101	680BT Tool arm	1
9	DB0200302	Sliding Block Spring	2
10	DB0200403	Sliding Block Cover	2
11	DB0200701	Terminal Pin	2
12	M08125065	Nut	2
13	MB05080010	Head Cross Bolt	18
14	MI05080016	CAP	8
15	MI08125035	CAP	4
16	M601	Greaser	2
17	W08	Washer	2
18	WS08	Spring Washer	4
19	YB40 45	Steel Circle	2

MOUNTING ASSEMBLY PARTS LIST			
ITEM	PART NUMBER	DESCRIPTION	QTY
1	DE0100113	Main Body	1
2	DE0100203	Disk	1
3	DE0100403	Tool Down Claw Plate	2
4	DE0100502	Tool Pot Position Seat	1
5	DE0100606	Air Cylinder Pushing Shaft	1
6	DE0100701	Tool Down Connecting Shaft	1
7	DE0100802	Air Cylinder Connecting Shaft	1
8	DE0100901	Air Cylinder Connecting Shaft	1
9	DE0101002	Pushing Shaft Position Pin	1
10	DE0101101	Connecting Pin	1
11	DE0101503	Disk Spindle	1
12	DE0101701	Origin Sensor Seat	1
13	DE0101801	Origin Sensor Fixed Slice	1
14	DE0102301	Tool Down Air Cylinder	1
15	DE0102402	Air Cylinder Joint	1
16	DE0102502	Air Cylinder Position Pin	1
17	DE0100310	Tool Down Claw	1
18	DE0107001	Tool Down Sensor Slice	1
19	DE0107102	Tool Down Sensor Seat	2
20	MA06100006	Bolt	1
21	MA08125040	Bolt	2
22	MI06100010	M6*1.0P*10L CAP	3
23	MI06100012	M6*1.0P*12L CAP	4
24	MI06100016	M6*1.0P*16L CAP	2
25	MI06100025	M6*1.0P*25L CAP	11
26	MI06100040	M6*1.0P*40L CAP	1
27	MI08125035	M8*1.25P*35L CAP	2
28	MI08125040	M8*1.25P*40L CAP	1
29	MI08125070	M8*1.25P*70L CAP	1
30	MI10150040	M10*1.5P*40L CAP	1

Wiring Diagram

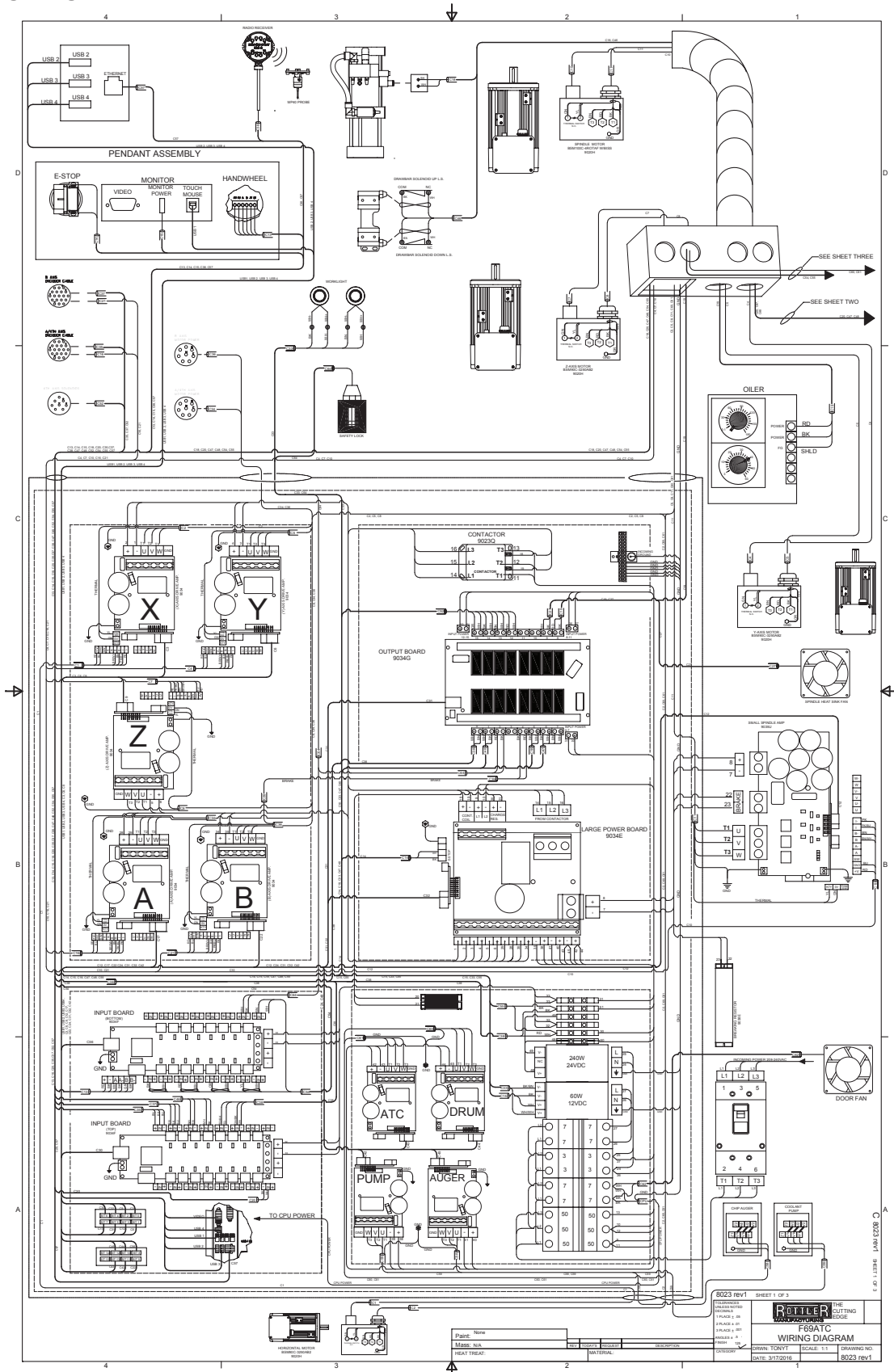

Tool Changer Wiring Diagram

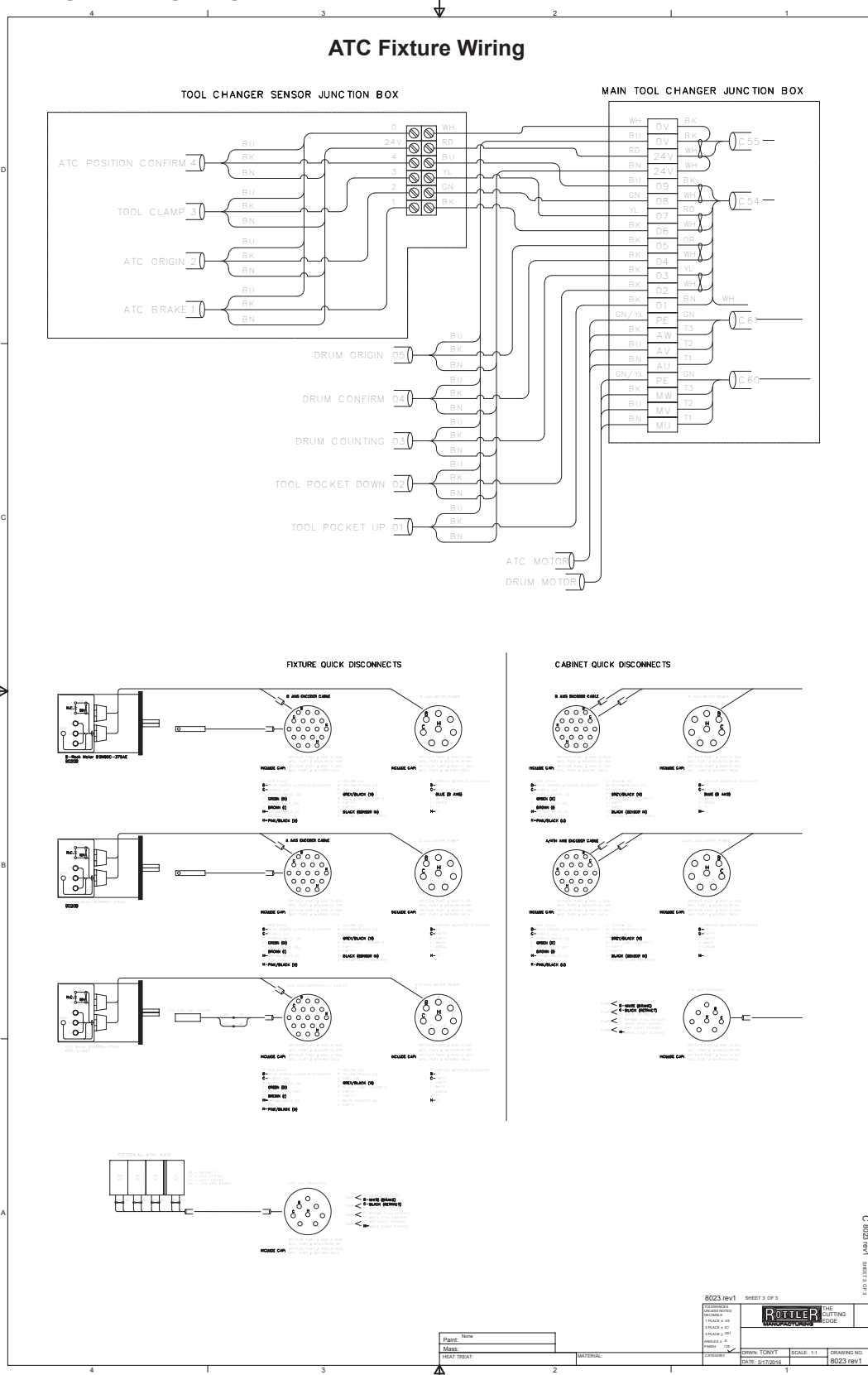

This page intentionally left blank

OPTIONS

Optional Equipment

Optional Equipment Catalog and Parts Manual are located on the Manual CD shipped with machine.

This page intentionally left blank

SDS

The Safety Data Sheets list shown in this section are the substances and materials that an operator is most likely to come in contact with while using this machine.

Other substances and materials are used in the manufacture, testing, and shipping of this machine. A complete list of the Safety Data Sheets of substances and materials used by Rottler Manufacturing during manufacturing, testing, and shipping is located on the Manual flash drive shipped with the machine. Safety Data Sheets are also located on the company web site: <http://www.rottlermfg.com/documentation.php>

- 1) Phillips 66 CP Oil**
- 2) Dyna Cool K-2002**
- 3) Mobil Vactra Oil #2**
- 4) Valvoline High Performance Gear Oil**
- 5) Valvoline Synpower Synthetic Oil**
- 6) Molywhite #00 Grease**

Safety Data Sheet

According to OSHA HCS 2012 (29 CFR 1910.1200), Health Canada HPR (SOR/2015-17), and Mexico NOM-018-STPS-2015



SECTION 1: Identification

Product Identifier **CP Oil**
Other means of identification Phillips 66 CP Oil 22
 Phillips 66 CP Oil 32
Code **LBPH817726**
Relevant identified uses Industrial Oil
Uses advised against All others
24 Hour Emergency Phone Number CHEMTREC: 1-800-424-9300
 CHEMTREC México 01-800-681-9531

Manufacturer/Supplier

Phillips 66 Lubricants
 P.O. Box 4428
 Houston, TX 77210

SDS Information

URL: www.phillips66.com/SDS
 Phone: 800-762-0942
 Email: SDS@P66.com

Customer Service

U.S.: 800-368-7128 or International: 1-832-765-2500
Technical Information
 1-877-445-9198

SECTION 2: Hazard identification

Classified Hazards

No classified hazards

Hazards Not Otherwise Classified (HNOC)

PHNOC: None known

HHNOC: None known

Label elements

No classified hazards

SECTION 3: Composition/information on ingredients

Chemical Name	CASRN	Concentration
Distillates, petroleum, hydrotreated heavy paraffinic	64742-54-7	>95

¹ All concentrations are percent by weight unless ingredient is a gas. Gas concentrations are in percent by volume.

SECTION 4: First aid measures

Eye Contact: If irritation or redness develops from exposure, flush eyes with clean water. If symptoms persist, seek medical attention.

Skin Contact: Remove contaminated shoes and clothing and cleanse affected area(s) thoroughly by washing with mild soap and water or a waterless hand cleaner. If irritation or redness develops and persists, seek medical attention.

Inhalation: First aid is not normally required. If breathing difficulties develop, move victim away from source of exposure and into fresh air in a position comfortable for breathing. Seek immediate medical attention.

LBPH817726 - CP Oil
Issue Date: 17-Apr-2018

Page 1/6
Status: FINAL

LBPH817726 - CP Oil
Issue Date: 17-Apr-2018

Page 2/6
Status: FINAL

Ingestion: First aid is not normally required; however, if swallowed and symptoms develop, seek medical attention.

Most important symptoms and effects, both acute and delayed: Inhalation of oil mists or vapors generated at elevated temperatures may cause respiratory irritation. Accidental ingestion can result in minor irritation of the digestive tract, nausea and diarrhea. Prolonged or repeated contact may dry skin and cause irritation.

Notes to Physician: Acute aspirations of large amounts of oil-laden material may produce a serious aspiration pneumonia. Patients who aspirate these oils should be followed for the development of long-term sequelae. Inhalation exposure to oil mists below current workplace exposure limits is unlikely to cause pulmonary abnormalities.

SECTION 5: Firefighting measures

NFPA 704: National Fire Protection Association

Health: 0 Flammability: 1 Instability: 0



0 = minimal hazard
1 = slight hazard
2 = moderate hazard
3 = severe hazard
4 = extreme hazard

Extinguishing Media: Dry chemical, carbon dioxide, foam, or water spray is recommended. Water or foam may cause frothing of materials heated above 212°F / 100°C. Carbon dioxide can displace oxygen. Use caution when applying carbon dioxide in confined spaces. Simultaneous use of foam and water on the same surface is to be avoided as water destroys the foam.

Specific hazards arising from the chemical

Unusual Fire & Explosion Hazards: This material may burn, but will not ignite readily. If container is not properly cooled, it can rupture in the heat of a fire.

Hazardous Combustion Products: Combustion may yield smoke, carbon monoxide, and other products of incomplete combustion. Oxides of sulfur, nitrogen or phosphorus may also be formed.

Special protective actions for fire-fighters: For fires beyond the initial stage, emergency responders in the immediate hazard area should wear protective clothing. When the potential chemical hazard is unknown, in enclosed or confined spaces, a self contained breathing apparatus should be worn. In addition, wear other appropriate protective equipment as conditions warrant (see Section 8). Isolate the hazard area and deny entry to unnecessary and unprotected personnel. Stop spill/release if it can be done safely. Move undamaged containers from immediate hazard area if it can be done safely. Water spray may be useful in minimizing or dispersing vapors and to protect personnel. Cool equipment exposed to fire with water, if it can be done safely. Avoid spreading burning liquid with water used for cooling purposes.

See Section 9 for Flammable Properties including Flash Point and Flammable (Explosive) Limits

SECTION 6: Accidental release measures

Personal precautions, protective equipment and emergency procedures: This material may burn, but will not ignite readily. Keep all sources of ignition away from spill/release. Stay upwind and away from spill/release. Avoid direct contact with material. For large spillages, notify persons down wind of the spill/release, isolate immediate hazard area and keep unauthorized personnel out. Wear appropriate protective equipment, including respiratory protection, as conditions warrant (see Section 8). See Sections 2 and 7 for additional information on hazards and precautionary measures.

Environmental Precautions: Stop and contain spill/release if it can be done safely. Prevent spilled material from entering sewers, storm drains, other unauthorized drainage systems, and natural waterways. Use water sparingly to minimize environmental contamination and reduce disposal requirements. If spill occurs on water notify appropriate authorities and advise shipping of any hazard. Spills into or upon navigable waters, the contiguous zone, or adjoining shorelines that cause a sheen or discoloration on the surface of the water, may require notification of the National Response Center (phone number 800-424-8802).

Methods and material for containment and cleaning up: Notify relevant authorities in accordance with all applicable regulations. Immediate cleanup of any spill is recommended. Dike far ahead of spill for later recovery or disposal. Absorb spill with inert material such as sand or vermiculite, and place in suitable container for disposal. If spilled on water remove with appropriate methods (e.g. skimming, booms or absorbents). In case of soil contamination, remove contaminated soil for remediation or disposal, in accordance with local regulations.

LBPH817726 - CP Oil
 Issue Date: 17-Apr-2018

Page 3/6
 Status: FINAL

Recommended measures are based on the most likely spillage scenarios for this material; however local conditions and regulations may influence or limit the choice of appropriate actions to be taken. See Section 13 for information on appropriate disposal.

SECTION 7: Handling and storage

Precautions for safe handling: Keep away from flames and hot surfaces. Wash thoroughly after handling. Use good personal hygiene practices and wear appropriate personal protective equipment (see section 8). Spills will produce very slippery surfaces. Do not enter confined spaces such as tanks or pits without following proper entry procedures such as ASTM D-4276 and 29CFR 1910.146. Do not wear contaminated clothing or shoes.

Conditions for safe storage: Keep container(s) tightly closed and properly labeled. Use and store this material in cool, dry, well-ventilated area away from heat and all sources of ignition. Store only in approved containers. Keep away from any incompatible material (see Section 10). Protect container(s) against physical damage.

"Empty" containers retain residue and may be dangerous. Do not pressurize, cut, weld, braze, solder, drill, grind, or expose such containers to heat, flame, sparks, or other sources of ignition. They may explode and cause injury or death. "Empty" drums should be completely drained, properly bunged, and promptly shipped to the supplier or a drum reconditioner. All containers should be disposed of in an environmentally safe manner and in accordance with governmental regulations. Before working on or in tanks which contain or have contained this material, refer to OSHA regulations, ANSI Z49.1, and other references pertaining to cleaning, repairing, welding, or other contemplated operations.

SECTION 8: Exposure controls/personal protection

Occupational exposure limits

The following constituents are the only constituents of the product which have a PEL, TLV or other recommended exposure limit. At this time, the other constituents have no known exposure limits.

Chemical Name	ACGIH	OSHA	Mexico	Phillips 66
Distillates, petroleum, hydrotreated heavy paraffinic	TWA: 5mg/m ³ STEL: 10 mg/m ³ as Oil Mist, if Generated	---	---	---

Note: State, local or other agencies or advisory groups may have established more stringent limits. Consult an industrial hygienist or similar professional, or your local agencies, for further information.

Biological occupational exposure limits

Note: This product, as supplied, does not contain any hazardous materials with occupational exposure limits established by the region specific regulatory bodies

Engineering controls: If current ventilation practices are not adequate to maintain airborne concentrations below the established exposure limits, additional engineering controls may be required.

Eye/Face Protection: The use of eye/face protection is not normally required; however, good industrial hygiene practice suggests the use of eye protection that meets or exceeds ANSI Z.87.1 whenever working with chemicals.

Skin/Hand Protection: The use of skin protection is not normally required; however, good industrial hygiene practice suggests the use of gloves or other appropriate skin protection whenever working with chemicals. Suggested protective materials: Nitrile rubber

Respiratory Protection: Where there is potential for airborne exposure above the exposure limit a NIOSH certified air purifying respirator equipped with R or P95 filters may be used.

A respiratory protection program that meets or is equivalent to OSHA 29 CFR 1910.134 and ANSI Z88.2 should be followed whenever workplace conditions warrant a respirator's use. Air purifying respirators provide limited protection and cannot be used in atmospheres that exceed the maximum use concentration (as directed by regulation or the manufacturer's instructions), in oxygen deficient (less than 19.5 percent oxygen) situations, or under conditions that are immediately dangerous to life and health (IDLH).

Suggestions provided in this section for exposure control and specific types of protective equipment are based on readily available information. Users should consult with the specific manufacturer to confirm the performance of their protective equipment. Specific situations may require consultation with industrial hygiene, safety, or engineering professionals.

SECTION 9: Physical and chemical properties

Note: Unless otherwise stated, values are determined at 20°C (68°F) and 760 mm Hg (1 atm). Data represent typical values and are not intended

LBPH817726 - CP Oil
Issue Date: 17-Apr-2018

Page 4/6
Status: FINAL

to be specifications.

<p>Appearance: Amber, Transparent Physical Form: Liquid Odor: Petroleum Odor Threshold: No data pH: Not applicable Vapor Density (air=1): >1 Upper Explosive Limits (vol % in air): No data Lower Explosive Limits (vol % in air): No data Evaporation Rate (nBuAc=1): No data Particle Size: Not applicable Percent Volatile: No data Flammability (solid, gas): Not applicable Solubility in Water: Negligible</p>	<p>Flash Point: > 302 °F / > 150 °C Test Method: Pensky-Martens Closed Cup (PMCC), ASTM D93, EPA 1010 Initial Boiling Point/Range: No data Vapor Pressure: <1 mm Hg Partition Coefficient (n-octanol/water) (Kow): No data Melting/Freezing Point: < -11 °F / < -24 °C Auto-ignition Temperature: No data Decomposition Temperature: No data Specific Gravity (water=1): 0.86 @ 60°F (15.6°C) Bulk Density: 7.1-7.2 lbs/gal Viscosity: 4.0 - 6 cSt @ 100°C; 20.5 - 35 cSt @ 40°C Pour Point: < -11 °F / < -24 °C</p>
--	--

SECTION 10: Stability and reactivity

Reactivity: Not chemically reactive.

Chemical stability: Stable under normal ambient and anticipated conditions of use.

Possibility of hazardous reactions: Hazardous reactions not anticipated.

Conditions to avoid: Extended exposure to high temperatures can cause decomposition. Avoid all possible sources of ignition.

Incompatible materials: Avoid contact with strong oxidizing agents and strong reducing agents.

Hazardous decomposition products: Not anticipated under normal conditions of use.

SECTION 11: Toxicological information

Information on Toxicological Effects

Substance / Mixture			
Acute Toxicity	Hazard	Additional Information	LC50/LD50 Data
Inhalation	Unlikely to be harmful		>5 mg/L (mist, estimated)
Dermal	Unlikely to be harmful		> 2 g/kg (estimated)
Oral	Unlikely to be harmful		> 5 g/kg (estimated)

Likely Routes of Exposure: Inhalation, eye contact, skin contact

Aspiration Hazard: Not expected to be an aspiration hazard

Skin Corrosion/Irritation: Not expected to be irritating. Repeated exposure may cause skin dryness or cracking.

Serious Eye Damage/Irritation: Not expected to be irritating.

Skin Sensitization: No information available on the mixture, however none of the components have been classified for skin sensitization (or are below the concentration threshold for classification).

Respiratory Sensitization: No information available.

Specific Target Organ Toxicity (Single Exposure): Not expected to cause organ effects from single exposure.

Specific Target Organ Toxicity (Repeated Exposure): Not expected to cause organ effects from repeated exposure.

Carcinogenicity: No information available on the mixture, however none of the components have been classified for carcinogenicity (or are below the concentration threshold for classification).

Germ Cell Mutagenicity: No information available on the mixture, however none of the components have been classified for

LBPH817726 - CP Oil
Issue Date: 17-Apr-2018

Page 5/6
Status: FINAL

germ cell mutagenicity (or are below the concentration threshold for classification).

Reproductive Toxicity: No information available on the mixture, however none of the components have been classified for reproductive toxicity (or are below the concentration threshold for classification).

Information on Toxicological Effects of Components

Distillates, petroleum, hydrotreated heavy paraffinic

Carcinogenicity: This oil has been highly refined by a variety of processes to reduce aromatics and improve performance characteristics. It meets the IP-346 criteria of less than 3 percent PAH's and is not considered a carcinogen by the International Agency for Research on Cancer.

SECTION 12: Ecological information

GHS Classification:

No classified hazards

Toxicity: All acute aquatic toxicity studies on samples of lubricant base oils show acute toxicity values greater than 100 mg/L for invertebrates, algae and fish. These tests were carried out on water accommodated fractions and the results are consistent with the predicted aquatic toxicity of these substances based on their hydrocarbon compositions.

Persistence and Degradability: The hydrocarbons in this material are not readily biodegradable, but since they can be degraded by microorganisms, they are regarded as inherently biodegradable.

Bioaccumulative Potential: Log Kow values measured for the hydrocarbon components of this material are greater than 5.3, and therefore regarded as having the potential to bioaccumulate. In practice, metabolic processes may reduce bioconcentration.

Mobility in Soil: Volatilization to air is not expected to be a significant fate process due to the low vapor pressure of this material. In water, base oils will float and spread over the surface at a rate dependent upon viscosity. There will be significant removal of hydrocarbons from the water by sediment adsorption. In soil and sediment, hydrocarbon components will show low mobility with adsorption to sediments being the predominant physical process. The main fate process is expected to be slow biodegradation of the hydrocarbon constituents in soil and sediment.

Other adverse effects: None anticipated.

SECTION 13: Disposal considerations

The generator of a waste is always responsible for making proper hazardous waste determinations and needs to consider state and local requirements in addition to federal regulations. This material, if discarded as produced, would not be a federally regulated RCRA "listed" hazardous waste and is not believed to exhibit characteristics of hazardous waste. See Sections 7 and 8 for information on handling, storage and personal protection and Section 9 for physical/chemical properties. It is possible that the material as produced contains constituents which are not required to be listed in the SDS but could affect the hazardous waste determination. Additionally, use which results in chemical or physical change of this material could subject it to regulation as a hazardous waste. This material under most intended uses would become "Used Oil" due to contamination by physical or chemical impurities. Whenever possible, Recycle used oil in accordance with applicable federal and state or local regulations. Container contents should be completely used and containers should be emptied prior to discard.

SECTION 14: Transport information

U.S. Department of Transportation (DOT)

UN Number: Not regulated

UN proper shipping name: None

Transport hazard class(es): None

Packing Group: None

Environmental Hazards: This product does not meet the DOT/UN/IMDG/IMO criteria of a marine pollutant

Special precautions for user: If shipped by land in a packaging having a capacity of 3,500 gallons or more, the provisions of 49 CFR, Part 130 apply. (Contains oil)

Transport in bulk according to Annex II of MARPOL 73/78 and the IBC Code: Not applicable

SECTION 15: Regulatory information

CERCLA/SARA - Section 302 Extremely Hazardous Substances and TPQs (in pounds)

LBPH817726 - CP Oil
Issue Date: 17-Apr-2018

Page 6/6
Status: FINAL

This material does not contain any chemicals subject to the reporting requirements of SARA 302 and 40 CFR 372.

CERCLA/SARA - Section 311/312 (Title III Hazard Categories)

Should this product meet EPCRA 311/312 Tier reporting criteria at 40 CFR 370, refer to Section 2 of this SDS for appropriate classifications.

CERCLA/SARA - Section 313 and 40 CFR 372

This material does not contain any chemicals subject to the reporting requirements of SARA 313 and 40 CFR 372.

EPA (CERCLA) Reportable Quantity (in pounds)

This material does not contain any chemicals with CERCLA Reportable Quantities.

California Proposition 65

This material does not contain any chemicals which are known to the State of California to cause cancer, birth defects or other reproductive harm at concentrations that trigger the warning requirements of California Proposition 65.

International Inventories

All components are either listed on the US TSCA Inventory, or are not regulated under TSCA. All components are either on the DSL, or are exempt from DSL listing requirements.

SECTION 16: Other information

Issue Date:	Previous Issue Date:	SDS Number	Status:
17-Apr-2018	23-Jun-2016	LBPH817726	FINAL

Revised Sections or Basis for Revision:

Exposure limits (Section 8); Regulatory information (Section 15)

Legend (pursuant to NOM-018-STPS-2015):

The information within is considered correct but is not exhaustive and will be used for guidance only, which is based on the current knowledge of the substance or mixture and is applicable to the appropriate safety precautions for the product.

Guide to Abbreviations:

ACGIH = American Conference of Governmental Industrial Hygienists; CASRN = Chemical Abstracts Service Registry Number; CEILING = Ceiling Limit (15 minutes); CERCLA = The Comprehensive Environmental Response, Compensation, and Liability Act; EPA = Environmental Protection Agency; GHS = Globally Harmonized System; HPR = Hazardous Products Regulations; IARC = International Agency for Research on Cancer; INSHT = National Institute for Health and Safety at Work; IOPC = International Oil Pollution Compensation; LEL = Lower Explosive Limit; NE = Not Established; NFPA = National Fire Protection Association; NTP = National Toxicology Program; OSHA = Occupational Safety and Health Administration; PEL = Permissible Exposure Limit (OSHA); SARA = Superfund Amendments and Reauthorization Act; STEL = Short Term Exposure Limit (15 minutes); TLV = Threshold Limit Value (ACGIH); TWA = Time Weighted Average (8 hours); UEL = Upper Explosive Limit; WHMIS = Worker Hazardous Materials Information System (Canada)

Disclaimer of Expressed and implied Warranties:

The information presented in this Safety Data Sheet is based on data believed to be accurate as of the date this Safety Data Sheet was prepared. HOWEVER, NO WARRANTY OF MERCHANTABILITY, FITNESS FOR ANY PARTICULAR PURPOSE, OR ANY OTHER WARRANTY IS EXPRESSED OR IS TO BE IMPLIED REGARDING THE ACCURACY OR COMPLETENESS OF THE INFORMATION PROVIDED ABOVE, THE RESULTS TO BE OBTAINED FROM THE USE OF THIS INFORMATION OR THE PRODUCT, THE SAFETY OF THIS PRODUCT, OR THE HAZARDS RELATED TO ITS USE. No responsibility is assumed for any damage or injury resulting from abnormal use or from any failure to adhere to recommended practices. The information provided above, and the product, are furnished on the condition that the person receiving them shall make their own determination as to the suitability of the product for their particular purpose and on the condition that they assume the risk of their use. In addition, no authorization is given nor implied to practice any patented invention without a license.



SAFETY DATA SHEET

DYNA COOL K-2002

Issue Date: 13-May-2015

Revision Date: 25-January-2018

Version 1

1. IDENTIFICATION

Product Identifier

Product Name DYNA COOL K-2002

Other means of identification

SDS # DYNA-004
Product Code 5428

Recommended use of the chemical and restrictions on use

Recommended use Metalworking fluid
Restrictions on use Industrial use only

Details of the supplier of the safety data sheet

Manufacturer Address

Company Name: DYNA TECH Chemical Specialties, Inc.
 Address: P. O. Box 34
 Colgate, WI 53017
 Telephone: 262-646-7600
 Fax: 262-820-9176

Emergency Telephone Number (24 hours/day): INFOTRAC 1-352-323-3500 (International)
 1-800-535-5053 (North America)

2. HAZARDS IDENTIFICATION

Hazard Classification Not classified as hazardous under 29CFR 1910.1200 (HazCom 2012)

Label Elements

Hazard Symbol: No symbol.
Signal Word: No signal word.
Hazard Statement: Not applicable.
Precautionary Statement: Not applicable.

Other hazards which do not result in GHS classification: None.

3. COMPOSITION/INFORMATION ON INGREDIENTS

Hazardous Component(s):

CHEMICAL NAME	CAS-No.	CONCENTRATION
Mineral oil	Confidential	20 – 50%
Triethanolamine	102-71-6	5 – 10%
Ethoxylated alcohol	Confidential	1 – 5%
Biocide	Confidential	1 - 5%
Sodium hydroxide	1310-73-2	10 – 20%

Specific chemical identities and/or exact percentages have been withheld as trade secrets.

DYNA-004 – DYNA COOL K-2002

Revision Date: 25-January-2018

4. FIRST-AID MEASURES

Ingestion:	Rinse mouth thoroughly. Call a POISON CENTER/doctor/.../ if you feel unwell. Do NOT induce vomiting.
Inhalation:	Move to fresh air. Call a POISON CENTER/doctor/.../ if you feel unwell.
Skin Contact:	Remove contaminated/saturated clothing and shoes. Wash contact areas with soap and water. If skin irritation occurs: Get medical advice/attention.
Eye Contact:	Flush thoroughly with water. If irritation occurs, get medical assistance. Continue to rinse for at least 15 minutes.

Most important symptoms/effects, acute and delayed

Symptoms: No data available.

Indication of immediate medical attention and special treatment needed

Treatment: Get medical attention as appropriate or if symptoms persist.

5. FIRE-FIGHTING MEASURES

General Fire Hazards:	No unusual fire or explosion hazards noted.
Suitable (and unsuitable) extinguishing media	
Suitable extinguishing media:	Water spray, fog, CO ₂ , dry chemical or regular foam. Use fire-extinguishing media appropriate for surrounding materials.
Unsuitable extinguishing media:	Do not use water jet as an extinguisher, as this will spread the fire.
Specific hazards arising from the chemical:	Heat may cause the containers to explode. During fire, gases hazardous to health may be formed.
Special protective equipment and precautions for firefighters	
Special firefighting procedures:	No data available.
Special protective equipment for firefighters:	Firefighters must use standard protective equipment including flame retardant coat, helmet with face shield, gloves, rubber boots, and in enclosed spaces, SCBA.

6. ACCIDENTAL RELEASE MEASURES

Personal precautions, protective equipment and emergency procedures:	See Section 8 of the SDS for Personal Protective Equipment. Do not touch damaged containers or spilled material unless wearing appropriate protective clothing. Keep unauthorized personnel away. Ensure adequate ventilation.
Methods and material for containment and cleaning up:	Absorb with sand or other inert absorbent. Stop the flow of material, if this is without risk.
Environmental Precautions:	Avoid release to the environment. Do not contaminate water sources or sewer. Prevent further leakage or spillage if safe to do so.

DYNA-004 – DYNA COOL K-2002

Revision Date: 25-January-2018

7. HANDLING AND STORAGE

- Precautions for safe handling:** End-users should follow industry best practices for handling and using this product.
- Guidance may be found using the current version of ASTM Standard E1497-05: Standard Practice for Selection and Safe Use of Water-Miscible and Straight Oil Metal Removal Fluids. Contains amines. Do not add sodium nitrite or other nitrosating agents which may form cancer causing nitrosamines. Contains a component that when heated at or above 300F (150C) may generate Formaldehyde vapors. Observe good industrial hygiene practices. Wear appropriate personal protective equipment. Do not expose to intense heat as product may expand and pressurize container.
- Conditions for safe storage, including any incompatibilities:** Store in original tightly closed container. Avoid contact with oxidizing agents. Store away from incompatible materials.

8. EXPOSURE CONTROLS/PERSONAL PROTECTION

Exposure Limits

CHEMICAL NAME	TYPE	EXPOSURE LIMIT VALUES	SOURCE
Mineral oil - Mist.	PEL	5 mg/m ³	US. OSHA Table Z-1 Limits for Air Contaminants (29 CFR 1910.1000)
Mineral oil – Mist.	STEL	10 mg/m ³	US. OSHA Table Z-1 Limits for Air Contaminants (29 CFR 1910.1000)
Triethanolamine	TWA	5 mg/m ³	US. ACGIH Threshold Limit Values (03 2012)
Sodium hydroxide	PEL	2 mg/m ³	US. OSHA Table Z-1 Limits for Air Contaminant (29 CFR 1910-1000) (02 2006)
Sodium hydroxide	Ceiling	2 mf/m ³	US. ACGIH Threshold Limit Values (03-2012)

- Protective Measures:** Use personal protective equipment as required.
- Respiratory Protection:** In case of inadequate ventilation, use suitable respirator. Seek advice from supervisor on the company's respiratory protection standards.
- Eye Protection:** Wear safety glasses with side shields (or goggles).
- Skin and Body Protection:** Wear chemical-resistant gloves, footwear, and protective clothing appropriate for the risk of exposure. Contact health and safety professional or manufacturer for specific information.
- Hygiene measures:** Always observe good personal hygiene measures, such as washing after handling the material and before eating, drinking, and/or smoking. Contaminated work clothing should be laundered prior to re-use. Discard contaminated footwear that cannot be cleaned. Avoid contact with skin, eyes, and clothing.

DYNA-004 – DYNA COOL K-2002

Revision Date: 25-January-2018

9. PHYSICAL AND CHEMICAL PROPERTIES**Appearance**

Physical state:	Liquid
Form:	No data available.
Color:	Blue
Odor:	Mild
Odor threshold:	No data available.
pH:	No data available.
Melting point/freezing point:	No data available.
Initial boiling point and boiling range:	No data available.
Flash Point:	Not applicable
Evaporation rate:	No data available.
Flammability (solid, gas):	No data available.
Upper/lower limit on flammability or explosive limits	
Flammability limit - upper (%):	No data available.
Flammability limit - lower (%):	No data available.
Explosive limit - upper (%):	No data available.
Explosive limit - lower (%):	No data available.
Vapor pressure:	No data available.
Vapor density:	No data available.
Relative density:	1.07
Solubility(ies)	
Solubility in water:	Soluble.
Solubility (other):	No data available.
Partition coefficient (n-octanol/water):	No data available.
Auto-ignition temperature:	No data available.
Decomposition temperature:	No data available.
Viscosity:	> 20.5 mm ² /s (40 °C)
Other Information	
VOC:	10.18 g/l (ASTM E 1868-10)

10. STABILITY AND REACTIVITY

Reactivity:	Not reactive during normal use.
Chemical Stability:	Material is stable under normal conditions.
Possibility of Hazardous Reactions:	None under normal conditions.
Conditions to Avoid:	Avoid heat or contamination.
Incompatible Materials:	No data available.
Hazardous Decomposition Products:	Formaldehyde

DYNA-004 – DYNA COOL K-2002

Revision Date: 25-January-2018

11. TOXICOLOGICAL INFORMATION**Information on likely routes of exposure**

Ingestion:	May be ingested by accident. Ingestion may cause irritation and malaise.
Inhalation:	Inhalation is the primary route of exposure. In high concentrations, vapors, fumes or mists may irritate nose, throat and mucus membranes.
Skin Contact:	Prolonged skin contact may cause redness and irritation.
Eye Contact:	Eye contact is possible and should be avoided.

Symptoms related to the physical, chemical and toxicological characteristics

Ingestion:	No data available.
Inhalation:	No data available.
Skin Contact:	No data available.
Eye Contact:	No data available.

Information on toxicological effects**Acute toxicity (list all possible routes of exposure)**

Oral Product:	ATEmix (): > 5000 mg/kg
Dermal Product:	ATEmix (): 2000-5000 mg/kg
Inhalation Product:	Not classified for acute toxicity based on available data.
Repeated Dose Toxicity Product:	No data available.

Skin Corrosion/Irritation Product:	No data available.
Serious Eye Damage/Eye Irritation Product:	No data available.
Respiratory or Skin Sensitization Product:	May cause an allergic skin reaction.
Carcinogenicity Product:	No data available.

IARC Monographs on the Evaluation of Carcinogenic Risks to Humans:

No carcinogenic components identified.

U.S. National Toxicology Program (NTP) Report on Carcinogens:

No carcinogenic components identified.

U.S. OSHA Specifically Regulated Substances (29 CFR 1910.1001-1050):

No carcinogenic components identified.

Germ Cell Mutagenicity

In Vitro Product:	No data available.
In Vivo Product:	No data available.

Reproductive Toxicity Product: No data available**Specific Target Organ Toxicity – Single Exposure Product:** No data available**Specific Target Organ Toxicity – Repeated Exposure Product:** No data available**Aspiration Hazard Product:** No data available.**Other effects:** No data available.

DYNA-004 – DYNA COOL K-2002

Revision Date: 25-January-2018

12. ECOLOGICAL INFORMATION

General information: This product has not been evaluated for ecological toxicity or other environmental effects.

13. DISPOSAL CONSIDERATIONS

Disposal instructions: Discharge, treatment, or disposal may be subject to national, state, or local laws. Dispose of waste at an appropriate treatment and disposal facility in accordance with applicable laws and regulations, and product characteristics at time of disposal. It is the responsibility of the product user or owner to determine at the time of disposal, which waste regulations, must be applied.

Contaminated Packaging: Empty containers should be taken to an approved waste handling site for recycling or disposal.

14. TRANSPORT INFORMATION

DOT Not regulated

IMDG Not regulated.

IATA Not regulated

15. REGULATORY INFORMATION**US Federal Regulations****US. OSHA Specifically Regulated Substances (29 CFR 1910.1001-1050)**

None present or none present in regulated quantities.

Superfund Amendments and Reauthorization Act of 1986 (SARA)**Hazard Categories**

Not listed.

SARA 313 (TRI Reporting)

None present or none present in regulated quantities.

US State Regulations**US. California Proposition 65**

This product contains chemical(s) known to the State of California to cause cancer and/or to cause birth defects or other reproductive harm.

16. OTHER INFORMATION

Issue Date: 13-May-2015
Revision Date: 25-January-2018
Revision Note: Updated information.
Version #: 1
Further Information: No data available.

Disclaimer

The information provided in this Safety Data Sheet is correct to the best of our knowledge, information and belief at the date of its publication. The information given is designed only as a guidance for safe handling, use, processing, storage, transportation, disposal and release and is not to be considered a warranty or quality specification. This information should be used to make an independent determination of the methods to safeguard workers and the environment. The information relates only to the specific material designated and may not be valid for such material used in combination with any other materials or in any process, unless specified in the text.

END OF SAFETY DATA SHEET



Product Name: MOBIL VACTRA OIL NO. 2
 Revision Date: 30 Aug 2018
 Page 1 of 10

SAFETY DATA SHEET

SECTION 1 PRODUCT AND COMPANY IDENTIFICATION

PRODUCT

Product Name: MOBIL VACTRA OIL NO. 2
Product Description: Base Oil and Additives
Product Code: 201560901015, 600494-85
Intended Use: Lubricant

COMPANY IDENTIFICATION

Supplier: East Coast Lubes Pty Ltd (Queensland and Northern Territory)
 A.B.N. 37 117 203 611
 Cnr North and Mort Streets
 Toowoomba, Queensland 4350 Australia

24 Hour Emergency Telephone 1300 131 001
Supplier General Contact 1800 069 019

Supplier: Southern Cross Lubes (Victoria and Tasmania, New South Wales and
 Australian Capital Territory)
 58-66 Ajax Road
 Altona, Victoria 3018, Australia

24 Hour Emergency Telephone 1300 131 001
Product Technical Information
Supplier General Contact 1300 466 245
 1300 552 861

Supplier: Perkal Pty Ltd Trading as Statewide Oil (Western Australia)
 A.B.N. 43 009 283 363
 14 Beete Street
 Welshpool, Western Australia 6106 Australia

24 Hour Emergency Telephone (8:00am to 4:30pm Mon to Fri) 1300 919 904
Product Technical Information
Supplier General Contact (08) 9350 6777
 (08) 9350 6777

Supplier: Perkal Pty Ltd Trading as Statewide Oil (South Australia)
 A.B.N. 43 009 283 363
 6-10 Streiff Rd
 Wingfield, South Australia 5013 Australia

24 Hour Emergency Telephone (8:00am to 4:30pm Mon to Fri) 1300 919 904
Product Technical Information
Supplier General Contact (08) 8359 8995
 (08) 8359 8995

SECTION 2 HAZARDS IDENTIFICATION



Product Name: MOBIL VACTRA OIL NO. 2
 Revision Date: 30 Aug 2018
 Page 2 of 10

This material is not hazardous according to regulatory guidelines (see (M)SDS Section 15).

Contains: PHOSPHORIC ACID ESTERS, AMINE SALT May produce an allergic reaction.

Other hazard information:

Physical / Chemical Hazards:

No significant hazards.

Health Hazards:

High-pressure injection under skin may cause serious damage. Excessive exposure may result in eye, skin, or respiratory irritation.

Environmental Hazards:

No significant hazards.

NOTE: This material should not be used for any other purpose than the intended use in Section 1 without expert advice. Health studies have shown that chemical exposure may cause potential human health risks which may vary from person to person.

SECTION 3 COMPOSITION / INFORMATION ON INGREDIENTS

This material is defined as a mixture.

Reportable Hazardous Substance(s) or Complex Substance(s)

Name	CAS#	Concentration*	GHS Hazard Codes
2,6-DI-TERT-BUTYL-P-CRESOL	128-37-0	0.1 - < 1%	H400(M factor 1), H410(M factor 1)
PHOSPHORIC ACID ESTERS, AMINE SALT	Confidential	0.1 - < 1%	H227, H302, H317, H318, H401, H411

* All concentrations are percent by weight unless ingredient is a gas. Gas concentrations are in percent by volume. Other ingredients determined not to be hazardous up to 100%.

SECTION 4 FIRST AID MEASURES

INHALATION

Remove from further exposure. For those providing assistance, avoid exposure to yourself or others. Use adequate respiratory protection. If respiratory irritation, dizziness, nausea, or unconsciousness occurs, seek immediate medical assistance. If breathing has stopped, assist ventilation with a mechanical device or use mouth-to-mouth resuscitation.

SKIN CONTACT

Wash contact areas with soap and water. If product is injected into or under the skin, or into any part of the body, regardless of the appearance of the wound or its size, the individual should be evaluated immediately by



Product Name: MOBIL VACTRA OIL NO. 2
Revision Date: 30 Aug 2018
Page 3 of 10

a physician as a surgical emergency. Even though initial symptoms from high pressure injection may be minimal or absent, early surgical treatment within the first few hours may significantly reduce the ultimate extent of injury.

EYE CONTACT

Flush thoroughly with water. If irritation occurs, get medical assistance.

INGESTION

First aid is normally not required. Seek medical attention if discomfort occurs.

NOTE TO PHYSICIAN

None

SECTION 5 FIRE FIGHTING MEASURES**EXTINGUISHING MEDIA**

Appropriate Extinguishing Media: Use water fog, foam, dry chemical or carbon dioxide (CO₂) to extinguish flames.

Inappropriate Extinguishing Media: Straight streams of water

FIRE FIGHTING

Fire Fighting Instructions: Evacuate area. Prevent run-off from fire control or dilution from entering streams, sewers or drinking water supply. Fire-fighters should use standard protective equipment and in enclosed spaces, self-contained breathing apparatus (SCBA). Use water spray to cool fire exposed surfaces and to protect personnel.

Hazardous Combustion Products: Aldehydes, Incomplete combustion products, Oxides of carbon, Smoke, Fume, Sulphur oxides

FLAMMABILITY PROPERTIES

Flash Point [Method]: >205°C (401°F) [ASTM D-92]

Flammable Limits (Approximate volume % in air): LEL: 0.9 UEL: 7.0

Autoignition Temperature: N/D

SECTION 6 ACCIDENTAL RELEASE MEASURES**NOTIFICATION PROCEDURES**

In the event of a spill or accidental release, notify relevant authorities in accordance with all applicable regulations.

PROTECTIVE MEASURES

Avoid contact with spilled material. See Section 5 for fire fighting information. See the Hazard Identification Section for Significant Hazards. See Section 4 for First Aid Advice. See Section 8 for advice on the minimum requirements for personal protective equipment. Additional protective measures may be necessary, depending on the specific circumstances and/or the expert judgment of the emergency responders.

For emergency responders: Respiratory protection: respiratory protection will be necessary only in special cases, e.g., formation of mists. Half-face or full-face respirator with filter(s) for dust/organic vapor or Self



Product Name: MOBIL VACTRA OIL NO. 2

Revision Date: 30 Aug 2018

Page 4 of 10

Contained Breathing Apparatus (SCBA) can be used depending on the size of spill and potential level of exposure. If the exposure cannot be completely characterized or an oxygen deficient atmosphere is possible or anticipated, SCBA is recommended. Work gloves that are resistant to hydrocarbons are recommended. Gloves made of polyvinyl acetate (PVA) are not water-resistant and are not suitable for emergency use. Chemical goggles are recommended if splashes or contact with eyes is possible. Small spills: normal antistatic work clothes are usually adequate. Large spills: full body suit of chemical resistant, antistatic material is recommended.

SPILL MANAGEMENT

Land Spill: Stop leak if you can do so without risk. Recover by pumping or with suitable absorbent.

Water Spill: Stop leak if you can do so without risk. Confine the spill immediately with booms. Warn other shipping. Remove from the surface by skimming or with suitable absorbents. Seek the advice of a specialist before using dispersants.

Water spill and land spill recommendations are based on the most likely spill scenario for this material; however, geographic conditions, wind, temperature, (and in the case of a water spill) wave and current direction and speed may greatly influence the appropriate action to be taken. For this reason, local experts should be consulted. Note: Local regulations may prescribe or limit action to be taken.

ENVIRONMENTAL PRECAUTIONS

Large Spills: Dyke far ahead of liquid spill for later recovery and disposal. Prevent entry into waterways, sewers, basements or confined areas.

SECTION 7 HANDLING AND STORAGE

HANDLING

Prevent small spills and leakage to avoid slip hazard. Material can accumulate static charges which may cause an electrical spark (ignition source). When the material is handled in bulk, an electrical spark could ignite any flammable vapors from liquids or residues that may be present (e.g., during switch-loading operations). Use proper bonding and/or earthing procedures. However, bonding and earthing may not eliminate the hazard from static accumulation. Consult local applicable standards for guidance. Additional references include American Petroleum Institute 2003 (Protection Against Ignitions Arising out of Static, Lightning and Stray Currents) or National Fire Protection Agency 77 (Recommended Practice on Static Electricity) or CENELEC CLC/TR 50404 (Electrostatics - Code of practice for the avoidance of hazards due to static electricity).

Static Accumulator: This material is a static accumulator.

STORAGE

The type of container used to store the material may affect static accumulation and dissipation. Do not store in open or unlabelled containers. Keep away from incompatible materials.

Material is defined under the National Standard [NOHSC:1015] Storage and Handling of Workplace Dangerous Goods.

SECTION 8 EXPOSURE CONTROLS / PERSONAL PROTECTION

EXPOSURE LIMIT VALUES

Exposure limits/standards (Note: Exposure limits are not additive)

Substance Name	Form	Limit/Standard	Note	Source
2,6-DI-TERT-BUTYL-P-CRESOL		TWA 10 mg/m ³		Australia OELs



Product Name: MOBIL VACTRA OIL NO. 2

Revision Date: 30 Aug 2018

Page 5 of 10

2,6-DI-TERT-BUTYL-P-CRESOL	Inhalable fraction and vapour	TWA	2 mg/m3			ACGIH
----------------------------	-------------------------------	-----	---------	--	--	-------

Exposure limits/standards for materials that can be formed when handling this product:

NOTE: Limits/standards shown for guidance only. Follow applicable regulations.

Biological limits

No biological limits allocated.

ENGINEERING CONTROLS

The level of protection and types of controls necessary will vary depending upon potential exposure conditions. Control measures to consider:

No special requirements under ordinary conditions of use and with adequate ventilation.

PERSONAL PROTECTION

Personal protective equipment selections vary based on potential exposure conditions such as applications, handling practices, concentration and ventilation. Information on the selection of protective equipment for use with this material, as provided below, is based upon intended, normal usage.

Respiratory Protection: If engineering controls do not maintain airborne contaminant concentrations at a level which is adequate to protect worker health, an approved respirator may be appropriate. Respirator selection, use, and maintenance must be in accordance with regulatory requirements, if applicable. Types of respirators to be considered for this material include:

Particulate

No special requirements under ordinary conditions of use and with adequate ventilation.

For high airborne concentrations, use an approved supplied-air respirator, operated in positive pressure mode. Supplied air respirators with an escape bottle may be appropriate when oxygen levels are inadequate, gas/vapour warning properties are poor, or if air purifying filter capacity/rating may be exceeded.

Hand Protection: Any specific glove information provided is based on published literature and glove manufacturer data. Glove suitability and breakthrough time will differ depending on the specific use conditions. Contact the glove manufacturer for specific advice on glove selection and breakthrough times for your use conditions. Inspect and replace worn or damaged gloves. The types of gloves to be considered for this material include:

Nitrile, Viton

No protection is ordinarily required under normal conditions of use.

Eye Protection: If contact is likely, safety glasses with side shields are recommended.

Skin and Body Protection: Any specific clothing information provided is based on published literature or manufacturer data. The types of clothing to be considered for this material include:

No skin protection is ordinarily required under normal conditions of use. In accordance with good industrial hygiene practices, precautions should be taken to avoid skin contact.



Product Name: MOBIL VACTRA OIL NO. 2

Revision Date: 30 Aug 2018

Page 6 of 10

Specific Hygiene Measures: Always observe good personal hygiene measures, such as washing after handling the material and before eating, drinking, and/or smoking. Routinely wash work clothing and protective equipment to remove contaminants. Discard contaminated clothing and footwear that cannot be cleaned. Practise good housekeeping.

ENVIRONMENTAL CONTROLS

Comply with applicable environmental regulations limiting discharge to air, water and soil. Protect the environment by applying appropriate control measures to prevent or limit emissions.

SECTION 9 PHYSICAL AND CHEMICAL PROPERTIES

Note: Physical and chemical properties are provided for safety, health and environmental considerations only and may not fully represent product specifications. Contact the Supplier for additional information.

GENERAL INFORMATION

Physical State: Liquid
Colour: Amber
Odour: Characteristic
Odour Threshold: N/D

IMPORTANT HEALTH, SAFETY, AND ENVIRONMENTAL INFORMATION

Relative Density (at 15 °C): 0.883
Flammability (Solid, Gas): N/A
Flash Point [Method]: >205°C (401°F) [ASTM D-92]
Flammable Limits (Approximate volume % in air): LEL: 0.9 UEL: 7.0
Autoignition Temperature: N/D
Boiling Point / Range: > 316°C (600°F)
Decomposition Temperature: N/D
Vapour Density (Air = 1): > 2 at 101 kPa
Vapour Pressure: < 0.013 kPa (0.1 mm Hg) at 20 °C
Evaporation Rate (n-butyl acetate = 1): N/D
pH: N/A
Log Pow (n-Octanol/Water Partition Coefficient): > 3.5
Solubility in Water: Negligible
Viscosity: 68 cSt (68 mm²/sec) at 40 °C | 8.6 cSt (8.6 mm²/sec) at 100°C
Oxidizing Properties: See Hazards Identification Section.

OTHER INFORMATION

Freezing Point: N/D
Melting Point: N/A
Pour Point: -6°C (21°F)
DMSO Extract (mineral oil only), IP-346: < 3 %wt

SECTION 10 STABILITY AND REACTIVITY

STABILITY: Material is stable under normal conditions.

CONDITIONS TO AVOID: Excessive heat. High energy sources of ignition.



Product Name: MOBIL VACTRA OIL NO. 2
 Revision Date: 30 Aug 2018
 Page 7 of 10

INCOMPATIBLE MATERIALS: Strong oxidisers

HAZARDOUS DECOMPOSITION PRODUCTS: Material does not decompose at ambient temperatures.

POSSIBILITY OF HAZARDOUS REACTIONS: Hazardous polymerization will not occur.

SECTION 11	TOXICOLOGICAL INFORMATION
-------------------	----------------------------------

INFORMATION ON TOXICOLOGICAL EFFECTS

Hazard Class	Conclusion / Remarks
Inhalation	
Acute Toxicity: No end point data for material.	Minimally Toxic. Based on assessment of the components.
Irritation: No end point data for material.	Negligible hazard at ambient/normal handling temperatures.
Ingestion	
Acute Toxicity: No end point data for material.	Minimally Toxic. Based on assessment of the components.
Skin	
Acute Toxicity: No end point data for material.	Minimally Toxic. Based on assessment of the components.
Skin Corrosion/Irritation: No end point data for material.	Negligible irritation to skin at ambient temperatures. Based on assessment of the components.
Eye	
Serious Eye Damage/Irritation: No end point data for material.	May cause mild, short-lasting discomfort to eyes. Based on assessment of the components.
Sensitisation	
Respiratory Sensitization: No end point data for material.	Not expected to be a respiratory sensitizer.
Skin Sensitization: No end point data for material.	Not expected to be a skin sensitizer. Based on assessment of the components.
Aspiration: Data available.	Not expected to be an aspiration hazard. Based on physico-chemical properties of the material.
Germ Cell Mutagenicity: No end point data for material.	Not expected to be a germ cell mutagen. Based on assessment of the components.
Carcinogenicity: No end point data for material.	Not expected to cause cancer. Based on assessment of the components.
Reproductive Toxicity: No end point data for material.	Not expected to be a reproductive toxicant. Based on assessment of the components.
Lactation: No end point data for material.	Not expected to cause harm to breast-fed children.
Specific Target Organ Toxicity (STOT)	
Single Exposure: No end point data for material.	Not expected to cause organ damage from a single exposure.
Repeated Exposure: No end point data for material.	Not expected to cause organ damage from prolonged or repeated exposure. Based on assessment of the components.

OTHER INFORMATION

For the product itself:

Component concentrations in this formulation would not be expected to cause skin sensitization, based on tests of the components, this formulation, or similar formulations.

Contains:

Base oil severely refined: Not carcinogenic in animal studies. Representative material passes IP-346, Modified Ames



Product Name: MOBIL VACTRA OIL NO. 2
Revision Date: 30 Aug 2018
Page 9 of 10

Empty Container Warning Empty Container Warning (where applicable): Empty containers may contain residue and can be dangerous. Do not attempt to refill or clean containers without proper instructions. Empty drums should be completely drained and safely stored until appropriately reconditioned or disposed. Empty containers should be taken for recycling, recovery, or disposal through suitably qualified or licensed contractor and in accordance with governmental regulations. DO NOT PRESSURISE, CUT, WELD, BRAZE, SOLDER, DRILL, GRIND, OR EXPOSE SUCH CONTAINERS TO HEAT, FLAME, SPARKS, STATIC ELECTRICITY, OR OTHER SOURCES OF IGNITION. THEY MAY EXPLODE AND CAUSE INJURY OR DEATH.

SECTION 14	TRANSPORT INFORMATION
-------------------	------------------------------

LAND (ADG): Not Regulated for Land Transport

SEA (IMDG): Not Regulated for Sea Transport according to IMDG-Code

Marine Pollutant: No

AIR (IATA): Not Regulated for Air Transport

SECTION 15	REGULATORY INFORMATION
-------------------	-------------------------------

This material is not considered hazardous according to Australia Model Work Health and Safety Regulations.

Product is not regulated according to Australian Dangerous Goods Code.

No Poison Schedule number allocated by the Standard for the Uniform Scheduling of Medicines and Poisons (SUSMP) established under the Therapeutic Goods Act.

AS1940 COMBUSTIBLE CLASS: C2

REGULATORY STATUS AND APPLICABLE LAWS AND REGULATIONS

Listed or exempt from listing/notification on the following chemical inventories (May contain substance(s) subject to notification to the EPA Active TSCA inventory prior to import to USA): AICS, DSL, ENCS, IECSC, KECI, PICCS, TCSI, TSCA

SECTION 16	OTHER INFORMATION
-------------------	--------------------------

KEY TO ABBREVIATIONS AND ACRONYMS:

N/D = Not determined, N/A = Not applicable, STEL = Short-Term Exposure Limit, TWA = Time-Weighted Average

KEY TO THE H-CODES CONTAINED IN SECTION 3 OF THIS DOCUMENT (for information only):

H227: Combustible liquid; Flammable Liquid, Cat 4

H302: Harmful if swallowed; Acute Tox Oral, Cat 4

H317: May cause allergic skin reaction; Skin Sensitization, Cat 1



Product Name: MOBIL VACTRA OIL NO. 2
Revision Date: 30 Aug 2018
Page 10 of 10

H318: Causes serious eye damage; Serious Eye Damage/Irr, Cat 1
H400: Very toxic to aquatic life; Acute Env Tox, Cat 1
H401: Toxic to aquatic life; Acute Env Tox, Cat 2
H410: Very toxic to aquatic life with long lasting effects; Chronic Env Tox, Cat 1
H411: Toxic to aquatic life with long lasting effects; Chronic Env Tox, Cat 2

THIS SAFETY DATA SHEET CONTAINS THE FOLLOWING REVISIONS:

Southern Cross Lubes (Victoria and Tasmania): Section 01: Supplier Mailing Address information was deleted.
Southern Cross Lubes (Victoria and Tasmania, New South Wales and Australian Capital Territory): Section 01: Supplier Mailing Address information was added.
Section 11 Acute Toxicity data - Header information was deleted.
Section 11 Substance Name - Header information was deleted.
Section 11 Substance Toxicity table - Header information was deleted.
Section 11 Substance Toxicology table information was deleted.
Section 12: information was modified.

The information and recommendations contained herein are, to the best of ExxonMobil's knowledge and belief, accurate and reliable as of the date issued. You can contact ExxonMobil to insure that this document is the most current available from ExxonMobil. The information and recommendations are offered for the user's consideration and examination. It is the user's responsibility to satisfy itself that the product is suitable for the intended use. If buyer repackages this product, it is the user's responsibility to insure proper health, safety and other necessary information is included with and/or on the container. Appropriate warnings and safe-handling procedures should be provided to handlers and users. Alteration of this document is strictly prohibited. Except to the extent required by law, republication or retransmission of this document, in whole or in part, is not permitted. The term, "ExxonMobil" is used for convenience, and may include any one or more of ExxonMobil Chemical Company, Exxon Mobil Corporation, or any affiliates in which they directly or indirectly hold any interest.

DGN: 7053124DAU (1014681)

Prepared by: Exxon Mobil Corporation
EMBSI, Clinton NJ USA
Contact Point: See Section 1 for Local Contact number

End of (M)SDS

	Page: 1
SAFETY DATA SHEET	Revision Date: 09/28/2016
	Print Date: 11/1/2016
	SDS Number: R0091437
Valvoline™ High Performance SAE 80W-90 Gear Oil ™ Trademark, Valvoline or its subsidiaries, regisred in various countries VV838	Version: 1.4

29 CFR 1910.1200 (OSHA HazCom 2012)

SECTION 1. PRODUCT AND COMPANY IDENTIFICATION

Product identifier

Trade name : Valvoline™ High Performance SAE 80W-90 Gear Oil

™ Trademark, Valvoline or its subsidiaries, regisred in various countries

Relevant identified uses of the substance or mixture and uses advised against

Details of the supplier of the safety data sheet Valvoline LLC 3499 Blazer Parkway Lexington, KY 40509 United States of America (USA) 1-800-TEAMVAL	Emergency telephone number 1-800-VALVOLINE Regulatory Information Number 1-800-TEAMVAL Product Information 1-800-TEAMVAL
---	--

SECTION 2. HAZARDS IDENTIFICATION

GHS Classification

Skin sensitization : Category 1

GHS label elements

Hazard pictograms :



Signal Word : Warning

Hazard Statements : May cause an allergic skin reaction.

Precautionary Statements : **Prevention:**
 Avoid breathing dust/ fume/ gas/ mist/ vapors/ spray.
 Contaminated work clothing must not be allowed out of the workplace.
 Wear protective gloves.
Response:
 IF ON SKIN: Wash with plenty of soap and water.
 If skin irritation or rash occurs: Get medical advice/ attention.
 Wash contaminated clothing before reuse.
Disposal:
 Dispose of contents/ container to an approved waste disposal plant.

		Page: 2
SAFETY DATA SHEET		Revision Date: 09/28/2016
		Print Date: 11/1/2016
		SDS Number: R0091437
Valvoline™ High Performance SAE 80W-90 Gear Oil ™ Trademark, Valvoline or its subsidiaries, regisred in various countries VV838		Version: 1.4

Other hazards

None known.

SECTION 3. COMPOSITION/INFORMATION ON INGREDIENTS

Substance / Mixture : Mixture

Chemical nature : Defatter

Hazardous components

Chemical name	CAS-No.	Classification	Concentration (%)
RESIDUAL OILS (PETROLEUM), SOLVENT-DEWAXED	64742-62-7	This material is not considered hazardous under the OSHA Hazard Communication Standard (HazCom 2012).	21.105
DISTILLATES (PETROLEUM), HYDROTREATED LIGHT	64742-47-8	Asp. Tox. 1; H304	1.393
AMINES, C12-14-TERT-ALKYL	68955-53-3	Flam. Liq. 4; H227 Acute Tox. 4; H302 Acute Tox. 2; H330 Acute Tox. 3; H311 Skin Corr. 1B; H314 Eye Dam. 1; H318 Skin Sens. 1A; H317	0.343

SECTION 4. FIRST AID MEASURES

General advice : Move out of dangerous area.
Show this safety data sheet to the doctor in attendance.
Do not leave the victim unattended.

If inhaled : If breathed in, move person into fresh air.
If unconscious, place in recovery position and seek medical advice.

		Page: 3
		Revision Date: 09/28/2016
SAFETY DATA SHEET		Print Date: 11/1/2016
		SDS Number: R0091437
Valvoline™ High Performance SAE 80W-90 Gear Oil ™ Trademark, Valvoline or its subsidiaries, registered in various countries VV838		Version: 1.4

If symptoms persist, call a physician.

- In case of skin contact : Remove contaminated clothing. If irritation develops, get medical attention.
If on skin, rinse well with water.
First aid is not normally required. However, it is recommended that exposed areas be cleaned by washing with soap and water.
Wash contaminated clothing before re-use.
- In case of eye contact : Flush eyes with water as a precaution.
Remove contact lenses.
Protect unharmed eye.
If eye irritation persists, consult a specialist.
- If swallowed : Do not give milk or alcoholic beverages.
Never give anything by mouth to an unconscious person.
If symptoms persist, call a physician.
- Most important symptoms and effects, both acute and delayed : Acute aspiration of large amounts of oil-laden material may produce a serious aspiration pneumonia. Patients who aspirate these oils should be followed for the development of long-term sequelae. Repeated aspiration of small quantities of mineral oil can produce chronic inflammation of the lungs (i.e. lipoid pneumonia) that may progress to pulmonary fibrosis. Symptoms are often subtle and radiological changes appear worse than clinical abnormalities. Occasionally, persistent cough, irritation of the upper respiratory tract, shortness of breath with exertion, fever, and bloody sputum occur. Inhalation exposure to oil mists below current workplace exposure limits is unlikely to cause pulmonary abnormalities.
Signs and symptoms of exposure to this material through breathing, swallowing, and/or passage of the material through the skin may include:
stomach or intestinal upset (nausea, vomiting, diarrhea)
irritation (nose, throat, airways)
Headache
Dizziness
May cause an allergic skin reaction.
- Notes to physician : No hazards which require special first aid measures.

SECTION 5. FIREFIGHTING MEASURES

- Suitable extinguishing media : Use extinguishing measures that are appropriate to local circumstances and the surrounding environment.
Water spray
Foam

	Page: 4
SAFETY DATA SHEET	Revision Date: 09/28/2016
	Print Date: 11/1/2016
	SDS Number: R0091437
Valvoline™ High Performance SAE 80W-90 Gear Oil ™ Trademark, Valvoline or its subsidiaries, regisred in various countries VV838	Version: 1.4

	Carbon dioxide (CO ₂) Dry chemical
Unsuitable extinguishing media	: High volume water jet
Specific hazards during firefighting	: Do not allow run-off from fire fighting to enter drains or water courses.
Hazardous combustion products	: carbon dioxide and carbon monoxide Hydrocarbons
Specific extinguishing methods	:
	Product is compatible with standard fire-fighting agents.
Further information	: Fire residues and contaminated fire extinguishing water must be disposed of in accordance with local regulations.
Special protective equipment for firefighters	: In the event of fire, wear self-contained breathing apparatus.

SECTION 6. ACCIDENTAL RELEASE MEASURES

Personal precautions, protective equipment and emergency procedures	: Use personal protective equipment. Persons not wearing protective equipment should be excluded from area of spill until clean-up has been completed.
Environmental precautions	: Prevent product from entering drains. Prevent further leakage or spillage if safe to do so. If the product contaminates rivers and lakes or drains inform respective authorities.
Methods and materials for containment and cleaning up	: Soak up with inert absorbent material (e.g. sand, silica gel, acid binder, universal binder, sawdust). Keep in suitable, closed containers for disposal.
Other information	: Comply with all applicable federal, state, and local regulations.

SECTION 7. HANDLING AND STORAGE

Advice on safe handling	: Do not breathe vapours/dust. Do not smoke. Persons susceptible to skin sensitisation problems or asthma, allergies, chronic or recurrent respiratory disease should not be employed in any process in which this mixture is being used.
-------------------------	---

		Page: 5
SAFETY DATA SHEET		Revision Date: 09/28/2016
		Print Date: 11/1/2016
		SDS Number: R0091437
Valvoline™ High Performance SAE 80W-90 Gear Oil ™ Trademark, Valvoline or its subsidiaries, regisred in various countries VV838		Version: 1.4

Container hazardous when empty.
 Avoid exposure - obtain special instructions before use.
 Avoid contact with skin and eyes.
 Smoking, eating and drinking should be prohibited in the application area.
 For personal protection see section 8.
 Dispose of rinse water in accordance with local and national regulations.

Conditions for safe storage : Keep container tightly closed in a dry and well-ventilated place.
 Containers which are opened must be carefully resealed and kept upright to prevent leakage.

SECTION 8. EXPOSURE CONTROLS/PERSONAL PROTECTION

Components with workplace control parameters

Components	CAS-No.	Value type (Form of exposure)	Control parameters / Permissible concentration	Basis
DISTILLATES (PETROLEUM), HYDROTREATED LIGHT	64742-47-8	TWA	5 mg/m3 Mist	OSHA Z-1
		TWA	200 mg/m3 (total hydrocarbon vapor)	ACGIH
		TWA	5 mg/m3 Mist	OSHA P0
		TWA	5 mg/m3 Mist	NIOSH REL
		ST	10 mg/m3 Mist	NIOSH REL
		PEL	5 mg/m3 particulate	CAL PEL

Hazardous components without workplace control parameters

Components	CAS-No.
AMINES, C12-14-TERT-ALKYL	68955-53-3

Engineering measures : Provide sufficient mechanical (general and/or local exhaust) ventilation to maintain exposure below exposure guidelines (if applicable) or below levels that cause known, suspected or apparent adverse effects.

Personal protective equipment

Respiratory protection : Respiratory protection is not required under normal conditions of use.

Hand protection

		Page: 6
		Revision Date: 09/28/2016
SAFETY DATA SHEET		Print Date: 11/1/2016
		SDS Number: R0091437
Valvoline™ High Performance SAE 80W-90 Gear Oil ™ Trademark, Valvoline or its subsidiaries, registered in various countries VV838		Version: 1.4

Remarks	: The suitability for a specific workplace should be discussed with the producers of the protective gloves.
Eye protection	: Not required under normal conditions of use. Wear splash-proof safety goggles if material could be misted or splashed into eyes.
Skin and body protection	: Wear as appropriate: Impervious clothing Safety shoes Choose body protection according to the amount and concentration of the dangerous substance at the work place. Discard gloves that show tears, pinholes, or signs of wear. Wear resistant gloves (consult your safety equipment supplier).
Hygiene measures	: Wash hands before breaks and at the end of workday.

SECTION 9. PHYSICAL AND CHEMICAL PROPERTIES

Physical state	: liquid
Colour	: amber
Odour	: No data available
Odour Threshold	: No data available
pH	: No data available
Melting point/freezing point	: No data available
Boiling point/boiling range	: > 424.9 °F / 218.3 °C (1013.333 hPa)
Flash point	: > 222 °C Method: Cleveland open cup
Evaporation rate	: > 1 Ethyl Ether
Flammability (solid, gas)	: No data available
Upper explosion limit	: No data available
Lower explosion limit	: No data available
Vapour pressure	: < 0.1000000 mmHg
Relative vapour density	: > 1AIR=1

	Page: 7
	Revision Date: 09/28/2016
SAFETY DATA SHEET	Print Date: 11/1/2016
	SDS Number: R0091437
Valvoline™ High Performance SAE 80W-90 Gear Oil ™ Trademark, Valvoline or its subsidiaries, regisred in various countries VV838	Version: 1.4

Relative density	: 0.89 (60.00 °F)
Density	: 0.8916 g/cm ³ (15.56 °C)
Solubility(ies)	
Water solubility	: No data available
Solubility in other solvents	: No data available
Partition coefficient: n-octanol/water	: No data available
Thermal decomposition	: No data available
Viscosity	
Viscosity, dynamic	: No data available
Viscosity, kinematic	: 146 mm ² /s (40 °C)
Oxidizing properties	: No data available

SECTION 10. STABILITY AND REACTIVITY

Reactivity	: No decomposition if stored and applied as directed.
Chemical stability	: Stable under recommended storage conditions.
Possibility of hazardous reactions	: Product will not undergo hazardous polymerization.
Incompatible materials	: Strong oxidizing agents
Hazardous decomposition products	Aldehydes carbon dioxide and carbon monoxide Carbon monoxide

SECTION 11. TOXICOLOGICAL INFORMATION

Information on likely routes of exposure	: Inhalation Skin contact Eye Contact Ingestion
--	--

	Page: 8
	Revision Date: 09/28/2016
SAFETY DATA SHEET	Print Date: 11/1/2016
	SDS Number: R0091437
Valvoline™ High Performance SAE 80W-90 Gear Oil ™ Trademark, Valvoline or its subsidiaries, regisred in various countries VV838	Version: 1.4

Acute toxicity

Not classified based on available information.

Components:

RESIDUAL OILS (PETROLEUM), SOLVENT-DEWAXED:

Acute oral toxicity : LD50 (Rat): > 5,000 mg/kg

Acute inhalation toxicity : LC50 (Rat): > 5.58 mg/l
Exposure time: 4 h
Test atmosphere: dust/mist
Assessment: Not classified as acutely toxic by inhalation under GHS.
Remarks: No mortality observed at this dose.

Acute dermal toxicity : LD50 (Rabbit): > 5,000 mg/kg
Remarks: No mortality observed at this dose.

LD50 (Rabbit): > 2,000 mg/kg
Assessment: Not classified as acutely toxic by dermal absorption under GHS.

DISTILLATES (PETROLEUM), HYDROTREATED LIGHT:

Acute oral toxicity : LD50 (Rat): > 5,000 mg/kg

Acute dermal toxicity : LD50 (Rabbit): > 3,160 mg/kg
Assessment: No adverse effect has been observed in acute dermal toxicity tests.

AMINES, C12-14-TERT-ALKYL:

Acute oral toxicity : LD50 (Rat): 612 mg/kg
Method: OECD Test Guideline 401

Acute inhalation toxicity : LC50 (Rat, female): 1.19 mg/l
Exposure time: 4 h
Test atmosphere: vapour
Method: OECD Test Guideline 403

Acute dermal toxicity : LD50 (Rat): 251 mg/kg
Method: OECD Test Guideline 402

Skin corrosion/irritation

Not classified based on available information.

Product:

Remarks: May cause skin irritation in susceptible persons.

Components:

RESIDUAL OILS (PETROLEUM), SOLVENT-DEWAXED:

Species: Rabbit

Result: No skin irritation

DISTILLATES (PETROLEUM), HYDROTREATED LIGHT:

		Page: 9
SAFETY DATA SHEET		Revision Date: 09/28/2016
		Print Date: 11/1/2016
		SDS Number: R0091437
Valvoline™ High Performance SAE 80W-90 Gear Oil ™ Trademark, Valvoline or its subsidiaries, regisred in various countries VV838		Version: 1.4

Result: Slight, transient irritation

AMINES, C12-14-TERT-ALKYL:

Species: Rabbit

Result: Corrosive after 3 minutes to 1 hour of exposure

Serious eye damage/eye irritation

Not classified based on available information.

Product:

Remarks: Vapours may cause irritation to the eyes, respiratory system and the skin.

Remarks: Unlikely to cause eye irritation or injury.

Components:

RESIDUAL OILS (PETROLEUM), SOLVENT-DEWAXED:

Species: Rabbit

Result: No eye irritation

DISTILLATES (PETROLEUM), HYDROTREATED LIGHT:

Result: Slight, transient irritation

AMINES, C12-14-TERT-ALKYL:

Species: Rabbit

Result: Corrosive

Respiratory or skin sensitisation

Skin sensitisation: May cause an allergic skin reaction.

Respiratory sensitisation: Not classified based on available information.

Components:

RESIDUAL OILS (PETROLEUM), SOLVENT-DEWAXED:

Test Type: Buehler Test

Species: Guinea pig

Assessment: Does not cause skin sensitisation.

AMINES, C12-14-TERT-ALKYL:

Test Type: Buehler Test

Species: Guinea pig

Assessment: The product is a skin sensitiser, sub-category 1A.

Germ cell mutagenicity

Not classified based on available information.

Components:

AMINES, C12-14-TERT-ALKYL:

Genotoxicity in vitro

: Test Type: Ames test

Test species: Salmonella typhimurium

Metabolic activation: with and without metabolic activation

Method: OECD Test Guideline 471

Result: negative

Genotoxicity in vivo

: Test Type: Micronucleus test

Test species: Mouse

Page: 10	
	
SAFETY DATA SHEET	Revision Date: 09/28/2016
	Print Date: 11/1/2016
	SDS Number: R0091437
Valvoline™ High Performance SAE 80W-90 Gear Oil ™ Trademark, Valvoline or its subsidiaries, regisred in various countries VV838	Version: 1.4

Cell type: Bone marrow
Method: OECD Test Guideline 474
Result: negative

Carcinogenicity

Not classified based on available information.

Reproductive toxicity

Not classified based on available information.

STOT - single exposure

Not classified based on available information.

STOT - repeated exposure

Not classified based on available information.

Aspiration toxicity

Not classified based on available information.

Product:

No aspiration toxicity classification

Components:

RESIDUAL OILS (PETROLEUM), SOLVENT-DEWAXED:

No aspiration toxicity classification

DISTILLATES (PETROLEUM), HYDROTREATED LIGHT:

May be fatal if swallowed and enters airways.

Further information**Product:**

Remarks: No data available

SECTION 12. ECOLOGICAL INFORMATION**Ecotoxicity****Product:**

Ecotoxicology Assessment

Acute aquatic toxicity : Acute aquatic toxicity Category 3; Harmful to aquatic life.

Chronic aquatic toxicity : Chronic aquatic toxicity Category 3; Harmful to aquatic life with long lasting effects.

Components:

RESIDUAL OILS (PETROLEUM), SOLVENT-DEWAXED:

Toxicity to fish : LL50 (Pimephales promelas (fathead minnow)): > 100 mg/l
Exposure time: 96 h
Test Type: static test
Test substance: WAF
Method: OECD Test Guideline 203
Remarks: No toxicity at the limit of solubility

Toxicity to daphnia and other aquatic invertebrates : EL50 (Daphnia magna (Water flea)): > 10,000 mg/l
Exposure time: 48 h
Test Type: static test
Test substance: WAF

	Page: 11
	Revision Date: 09/28/2016
SAFETY DATA SHEET	Print Date: 11/1/2016
	SDS Number: R0091437
Valvoline™ High Performance SAE 80W-90 Gear Oil ™ Trademark, Valvoline or its subsidiaries, registered in various countries VV838	Version: 1.4

Method: OECD Test Guideline 202

- Toxicity to algae : NOEL (Pseudokirchneriella subcapitata (green algae)): >= 100 mg/l
End point: Growth inhibition
Exposure time: 72 h
Test Type: static test
Test substance: WAF
Method: OECD Test Guideline 201
- Toxicity to fish (Chronic toxicity) : NOELR (Oncorhynchus mykiss (rainbow trout)): Calculated >= 1,000 mg/l
Exposure time: 14 d
- Toxicity to daphnia and other aquatic invertebrates (Chronic toxicity) : NOEL (Daphnia (water flea)): 10 mg/l
Exposure time: 21 d
Test substance: WAF
Method: OECD Test Guideline 211
- DISTILLATES (PETROLEUM), HYDROTREATED LIGHT:
Toxicity to fish : LC50 (Oncorhynchus mykiss (rainbow trout)): 2 - 5 mg/l
Exposure time: 96 h
Test Type: semi-static test
Test substance: WAF
Method: OECD Test Guideline 203
Remarks: Information given is based on data obtained from similar substances.
- Toxicity to daphnia and other aquatic invertebrates : EL50 (Water flea (Daphnia magna)): 1.4 mg/l
Exposure time: 48 h
Test Type: static test
Test substance: WAF
Method: OECD Test Guideline 202
Remarks: Information given is based on data obtained from similar substances.
- Toxicity to algae : EL50 (Pseudokirchneriella subcapitata (green algae)): > 1 - 3 mg/l
Exposure time: 72 h
Test Type: static test
Test substance: WAF
Method: OECD Test Guideline 201
Remarks: Information given is based on data obtained from similar substances.
- Toxicity to daphnia and other aquatic invertebrates (Chronic toxicity) : NOEL (Water flea (Daphnia magna)): 0.48 mg/l
Exposure time: 21 d
Test Type: semi-static test
Test substance: WAF
Method: OECD Test Guideline 211
Remarks: Information given is based on data obtained from similar substances.

	Page: 12
	Revision Date: 09/28/2016
SAFETY DATA SHEET	Print Date: 11/1/2016
	SDS Number: R0091437
Valvoline™ High Performance SAE 80W-90 Gear Oil ™ Trademark, Valvoline or its subsidiaries, registered in various countries VV838	Version: 1.4

AMINES, C12-14-TERT-ALKYL:

Toxicity to fish	: LC50 (Oncorhynchus mykiss (rainbow trout)): 1.3 mg/l Exposure time: 96 h Test Type: static test Method: OECD Test Guideline 203
Toxicity to daphnia and other aquatic invertebrates	: EC50 (Water flea (Daphnia magna)): 2.5 mg/l Exposure time: 48 h Test Type: static test
Toxicity to algae	: ErC50 (Pseudokirchneriella subcapitata (microalgae)): 0.44 mg/l End point: Growth inhibition Exposure time: 72 h Test Type: static test Method: OECD Test Guideline 201
	: NOEC (Pseudokirchneriella subcapitata (microalgae)): 0.05 mg/l End point: Growth inhibition Exposure time: 72 h Test Type: static test Method: OECD Test Guideline 201
M-Factor (Acute aquatic toxicity)	: 1
Toxicity to fish (Chronic toxicity)	: NOEC (Oncorhynchus mykiss (rainbow trout)): 0.078 mg/l Exposure time: 96 d Test Type: flow-through test Method: OECD Test Guideline 210
M-Factor (Chronic aquatic toxicity)	: 1

Persistence and degradability**Components:****RESIDUAL OILS (PETROLEUM), SOLVENT-DEWAXED:**

Biodegradability	: Result: Not readily biodegradable. Biodegradation: 2 - 4 % Exposure time: 28 d Method: OECD Test Guideline 301B
------------------	--

DISTILLATES (PETROLEUM), HYDROTREATED LIGHT:

Biodegradability	: Result: Inherently biodegradable Biodegradation: 58.6 % Exposure time: 28 d Method: OECD Test Guideline 301F
------------------	---

Remarks: Expected to be biodegradable

		Page: 13
		Revision Date: 09/28/2016
SAFETY DATA SHEET		Print Date: 11/1/2016
		SDS Number: R0091437
Valvoline™ High Performance SAE 80W-90 Gear Oil ™ Trademark, Valvoline or its subsidiaries, registered in various countries VV838		Version: 1.4

AMINES, C12-14-TERT-ALKYL:

Biodegradability : Result: Not readily biodegradable.
Biodegradation: 22 %
Exposure time: 28 d
Method: OECD Test Guideline 301D

No data available

Bioaccumulative potential**Components:****AMINES, C12-14-TERT-ALKYL:**

Partition coefficient: n-octanol/water : log Pow: 2.9

No data available

Mobility in soil**Components:**

No data available

Other adverse effects

No data available

Product:

Additional ecological information : An environmental hazard cannot be excluded in the event of unprofessional handling or disposal., Harmful to aquatic life with long lasting effects.

Components:**SECTION 13. DISPOSAL CONSIDERATIONS****Disposal methods**

General advice : The product should not be allowed to enter drains, water courses or the soil.
Do not contaminate ponds, waterways or ditches with chemical or used container.
Send to a licensed waste management company.

Dispose of in accordance with all applicable local, state and federal regulations.

Contaminated packaging : Empty remaining contents.
Dispose of as unused product.
Empty containers should be taken to an approved waste handling site for recycling or disposal.
Do not re-use empty containers.

SECTION 14. TRANSPORT INFORMATION**International transport regulations****REGULATION**

	Page: 14
SAFETY DATA SHEET	Revision Date: 09/28/2016
	Print Date: 11/1/2016
	SDS Number: R0091437
Valvoline™ High Performance SAE 80W-90 Gear Oil ™ Trademark, Valvoline or its subsidiaries, regisred in various countries VV838	Version: 1.4

ID NUMBER	PROPER SHIPPING NAME	*HAZARD CLASS	SUBSIDIARY HAZARDS	PACKING GROUP	MARINE POLLUTANT / LTD. QTY.
-----------	----------------------	---------------	--------------------	---------------	------------------------------

U.S. DOT - ROAD

Not dangerous goods

CFR_RAIL_C

Not dangerous goods

U.S. DOT - INLAND WATERWAYS

Not dangerous goods

TDG_ROAD_C

Not dangerous goods

TDG_RAIL_C

Not dangerous goods

TDG_INWT_C

Not dangerous goods

INTERNATIONAL MARITIME DANGEROUS GOODS

Not dangerous goods

INTERNATIONAL AIR TRANSPORT ASSOCIATION - CARGO

Not dangerous goods

INTERNATIONAL AIR TRANSPORT ASSOCIATION - PASSENGER

Not dangerous goods

MX_DG

Not dangerous goods

*ORM = ORM-D, CBL = COMBUSTIBLE LIQUID

Marine pollutant	no
------------------	----

	Page: 15
	Revision Date: 09/28/2016
SAFETY DATA SHEET	Print Date: 11/1/2016
	SDS Number: R0091437
Valvoline™ High Performance SAE 80W-90 Gear Oil ™ Trademark, Valvoline or its subsidiaries, registered in various countries VV838	Version: 1.4

Dangerous goods descriptions (if indicated above) may not reflect quantity, end-use or region-specific exceptions that can be applied. Consult shipping documents for descriptions that are specific to the shipment.

SECTION 15. REGULATORY INFORMATION

SARA 311/312 Hazards : Acute Health Hazard

SARA 313 This material does not contain any chemical components with known CAS numbers that exceed the threshold (De Minimis) reporting levels established by SARA Title III, Section 313.

California Prop 65 This product does not contain any chemicals known to State of California to cause cancer, birth defects, or any other reproductive harm.

The components of this product are reported in the following inventories:

TSCA : On TSCA Inventory

DSL : All components of this product are on the Canadian DSL

AICS : On the inventory, or in compliance with the inventory

ENCS : On the inventory, or in compliance with the inventory

KECI : On the inventory, or in compliance with the inventory

PICCS : On the inventory, or in compliance with the inventory

IECSC : On the inventory, or in compliance with the inventory

Inventories

AICS (Australia), DSL (Canada), IECSC (China), REACH (European Union), ENCS (Japan), ISHL (Japan), KECI (Korea), NZIoC (New Zealand), PICCS (Philippines), TCSI (Taiwan), TSCA (USA)

SECTION 16. OTHER INFORMATION

Further information

Revision Date: 09/28/2016

NFPA:

HMIS III:

		Page: 16
SAFETY DATA SHEET		Revision Date: 09/28/2016
		Print Date: 11/1/2016
		SDS Number: R0091437
Valvoline™ High Performance SAE 80W-90 Gear Oil ™ Trademark, Valvoline or its subsidiaries, registered in various countries VV838		Version: 1.4

<p style="text-align: center;">Special hazard.</p>	<table border="1"> <tr> <td style="background-color: blue; color: white;">HEALTH</td> <td style="text-align: center;">2</td> </tr> <tr> <td style="background-color: red; color: white;">FLAMMABILITY</td> <td style="text-align: center;">1</td> </tr> <tr> <td style="background-color: yellow; color: black;">PHYSICAL HAZARD</td> <td style="text-align: center;">0</td> </tr> </table> <p>0 = not significant, 1 = Slight, 2 = Moderate, 3 = High 4 = Extreme, * = Chronic</p>	HEALTH	2	FLAMMABILITY	1	PHYSICAL HAZARD	0
HEALTH	2						
FLAMMABILITY	1						
PHYSICAL HAZARD	0						

NFPA Flammable and Combustible Liquids Classification

Combustible Liquid Class IIIB

Full text of H-Statements

H227	Combustible liquid.
H302	Harmful if swallowed.
H304	May be fatal if swallowed and enters airways.
H311	Toxic in contact with skin.
H314	Causes severe skin burns and eye damage.
H317	May cause an allergic skin reaction.
H318	Causes serious eye damage.
H330	Fatal if inhaled.

Sources of key data used to compile the Safety Data Sheet

Valvoline internal data including own and sponsored test reports

The UNECE administers regional agreements implementing harmonised classification for labelling (GHS) and transport.

The information accumulated herein is believed to be accurate but is not warranted to be whether originating with the company or not. Recipients are advised to confirm in advance of need that the information is current, applicable, and suitable to their circumstances. This SDS has been prepared by Valvoline's Environmental Health and Safety Department (1-800-VALVOLINE).

List of abbreviations and acronyms that could be, but not necessarily are, used in this safety data sheet :

ACGIH : American Conference of Industrial Hygienists

BEI : Biological Exposure Index

CAS : Chemical Abstracts Service (Division of the American Chemical Society).

CMR : Carcinogenic, Mutagenic or Toxic for Reproduction

FG : Food grade

	Page: 17
	Revision Date: 09/28/2016
SAFETY DATA SHEET	Print Date: 11/1/2016
	SDS Number: R0091437
Valvoline™ High Performance SAE 80W-90 Gear Oil ™ Trademark, Valvoline or its subsidiaries, regisred in various countries VV838	Version: 1.4

GHS : Globally Harmonized System of Classification and Labeling of Chemicals.

H-statement : Hazard Statement

IATA : International Air Transport Association.

IATA-DGR : Dangerous Goods Regulation by the "International Air Transport Association" (IATA).

ICAO : International Civil Aviation Organization

ICAO-TI (ICAO) : Technical Instructions by the "International Civil Aviation Organization"

IMDG : International Maritime Code for Dangerous Goods

ISO : International Organization for Standardization

logPow : octanol-water partition coefficient

LCxx : Lethal Concentration, for xx percent of test population

LDxx : Lethal Dose, for xx percent of test population.

ICxx : Inhibitory Concentration for xx of a substance

Ecxx : Effective Concentration of xx

N.O.S.: Not Otherwise Specified

OECD : Organization for Economic Co-operation and Development

OEL : Occupational Exposure Limit

P-Statement : Precautionary Statement

PBT : Persistent , Bioaccumulative and Toxic

PPE : Personal Protective Equipment

STEL : Short-term exposure limit

STOT : Specific Target Organ Toxicity

TLV : Threshold Limit Value

TWA : Time-weighted average

vPvB : Very Persistent and Very Bioaccumulative

WEL : Workplace Exposure Level

CERCLA : Comprehensive Environmental Response, Compensation, and Liability Act

DOT : Department of Transportation

FIFRA : Federal Insecticide, Fungicide, and Rodenticide Act

HMIRC : Hazardous Materials Information Review Commission

HMIS : Hazardous Materials Identification System

NFPA : National Fire Protection Association

NIOSH : National Institute for Occupational Safety and Health

OSHA : Occupational Safety and Health Administration

PMRA : Health Canada Pest Management Regulatory Agency

RTK : Right to Know

WHMIS : Workplace Hazardous Materials Information System

		Page: 1
		Revision Date: 07/31/2016
SAFETY DATA SHEET		Print Date: 11/1/2016
		SDS Number: R0300933
Synpower™ 75W-90 SYNTHETIC GEAR OIL		Version: 1.1
VV975		

29 CFR 1910.1200 (OSHA HazCom 2012)

SECTION 1. PRODUCT AND COMPANY IDENTIFICATION

Product identifier

Trade name : Synpower™ 75W-90
SYNTHETIC GEAR OIL

Recommended use of the chemical and restrictions on use

Details of the supplier of the safety data sheet Valvoline LLC 3499 Blazer Parkway Lexington, KY 40509 United States of America SDS@valvoline.com	Emergency telephone number 1-800-VALVOLINE Regulatory Information Number 1-800-TEAMVAL Product Information 1-800-TEAMVAL
---	--

SECTION 2. HAZARDS IDENTIFICATION

GHS Classification

Eye irritation : Category 2A

Skin sensitization : Category 1

GHS Label element

Hazard pictograms :



Signal Word : Warning

Hazard Statements : May cause an allergic skin reaction.
Causes serious eye irritation.

Precautionary Statements : **Prevention:**
Avoid breathing dust/ fume/ gas/ mist/ vapors/ spray.
Wash skin thoroughly after handling.
Contaminated work clothing must not be allowed out of the workplace.
Wear eye protection/ face protection.
Wear protective gloves.
Response:

		Page: 2
		Revision Date: 07/31/2016
SAFETY DATA SHEET		Print Date: 11/1/2016
		SDS Number: R0300933
Synpower™ 75W-90 SYNTHETIC GEAR OIL		Version: 1.1
VV975		

IF ON SKIN: Wash with plenty of soap and water.
 IF IN EYES: Rinse cautiously with water for several minutes.
 Remove contact lenses, if present and easy to do. Continue rinsing.
 If skin irritation or rash occurs: Get medical advice/ attention.
 If eye irritation persists: Get medical advice/ attention.
 Wash contaminated clothing before reuse.
Disposal:
 Dispose of contents/ container to an approved waste disposal plant.

Other hazards

None known.

SECTION 3. COMPOSITION/INFORMATION ON INGREDIENTS

Substance / Mixture : Mixture

Chemical nature : Defatter

Hazardous components

Chemical Name	CAS-No.	Classification	Concentration (%)
HEAVY PARAFFINIC DISTILLATE	64742-54-7	Asp. Tox. 1; H304	61.42
DI-TERT-BUTYL POLYSULFIDE	68937-96-2	Flam. Liq. 4; H227 Skin Sens. 1B; H317	4.99
WHITE MINERAL OIL	8042-47-5	Not a hazardous substance or mixture.	2.90
Phosphoric acid esters, amine salt	91745-46-9	Acute Tox. 4; H302 Eye Dam. 1; H318 Skin Sens. 1; H317 Aquatic Acute 2; H401 Aquatic Chronic 2; H411	1.99

		Page: 3
		Revision Date: 07/31/2016
SAFETY DATA SHEET		Print Date: 11/1/2016
		SDS Number: R0300933
Synpower™ 75W-90 SYNTHETIC GEAR OIL		Version: 1.1
VV975		

SECTION 4. FIRST AID MEASURES

- General advice : Move out of dangerous area.
Show this safety data sheet to the doctor in attendance.
Do not leave the victim unattended.
- If inhaled : If breathed in, move person into fresh air.
If unconscious place in recovery position and seek medical advice.
If symptoms persist, call a physician.
- In case of skin contact : Remove contaminated clothing. If irritation develops, get medical attention.
If on skin, rinse well with water.
First aid is not normally required. However, it is recommended that exposed areas be cleaned by washing with soap and water.
Wash contaminated clothing before re-use.
- In case of eye contact : Immediately flush eye(s) with plenty of water.
Remove contact lenses.
Protect unharmed eye.
- If swallowed : Do not give milk or alcoholic beverages.
Never give anything by mouth to an unconscious person.
If symptoms persist, call a physician.
- Most important symptoms and effects, both acute and delayed : Acute aspiration of large amounts of oil-laden material may produce a serious aspiration pneumonia. Patients who aspirate these oils should be followed for the development of long-term sequelae. Repeated aspiration of small quantities of mineral oil can produce chronic inflammation of the lungs (i.e. lipoid pneumonia) that may progress to pulmonary fibrosis. Symptoms are often subtle and radiological changes appear worse than clinical abnormalities. Occasionally, persistent cough, irritation of the upper respiratory tract, shortness of breath with exertion, fever, and bloody sputum occur. Inhalation exposure to oil mists below current workplace exposure limits is unlikely to cause pulmonary abnormalities.
Signs and symptoms of exposure to this material through breathing, swallowing, and/or passage of the material through the skin may include:
acne
stomach or intestinal upset (nausea, vomiting, diarrhea)
irritation (nose, throat, airways)
May cause an allergic skin reaction.
Causes serious eye irritation.
- Notes to physician : No hazards which require special first aid measures.

		Page: 4
		Revision Date: 07/31/2016
SAFETY DATA SHEET		Print Date: 11/1/2016
		SDS Number: R0300933
Synpower™ 75W-90 SYNTHETIC GEAR OIL		Version: 1.1
VV975		

SECTION 5. FIREFIGHTING MEASURES

- Suitable extinguishing media : Use extinguishing measures that are appropriate to local circumstances and the surrounding environment.
Water spray
Foam
Carbon dioxide (CO₂)
Dry chemical
- Unsuitable extinguishing media : High volume water jet
- Specific hazards during firefighting : Do not allow run-off from fire fighting to enter drains or water courses.
- Hazardous combustion products : carbon dioxide and carbon monoxide
Hydrocarbons
Aldehydes
Sulphur oxides
Hydrogen chloride gas
Nitrogen oxides (NO_x)
Oxides of phosphorus
- Specific extinguishing methods :

Product is compatible with standard fire-fighting agents.
- Further information : Fire residues and contaminated fire extinguishing water must be disposed of in accordance with local regulations.
- Special protective equipment for firefighters : In the event of fire, wear self-contained breathing apparatus.

SECTION 6. ACCIDENTAL RELEASE MEASURES

- Personal precautions, protective equipment and emergency procedures : Use personal protective equipment.
Persons not wearing protective equipment should be excluded from area of spill until clean-up has been completed.
- Environmental precautions : Prevent product from entering drains.
Prevent further leakage or spillage if safe to do so.
If the product contaminates rivers and lakes or drains inform respective authorities.
- Methods and materials for containment and cleaning up : Soak up with inert absorbent material (e.g. sand, silica gel, acid binder, universal binder, sawdust).
Keep in suitable, closed containers for disposal.

		Page: 5
		Revision Date: 07/31/2016
SAFETY DATA SHEET		Print Date: 11/1/2016
		SDS Number: R0300933
Synpower™ 75W-90 SYNTHETIC GEAR OIL		Version: 1.1
VV975		

Other information : Comply with all applicable federal, state, and local regulations.

SECTION 7. HANDLING AND STORAGE

Advice on safe handling : Do not breathe vapours/dust.
Do not smoke.
Persons susceptible to skin sensitisation problems or asthma, allergies, chronic or recurrent respiratory disease should not be employed in any process in which this mixture is being used.
Container hazardous when empty.
Avoid exposure - obtain special instructions before use.
Avoid contact with skin and eyes.
Smoking, eating and drinking should be prohibited in the application area.
For personal protection see section 8.
Dispose of rinse water in accordance with local and national regulations.

Conditions for safe storage : Keep container tightly closed in a dry and well-ventilated place.
Containers which are opened must be carefully resealed and kept upright to prevent leakage.
Electrical installations / working materials must comply with the technological safety standards.

SECTION 8. EXPOSURE CONTROLS/PERSONAL PROTECTION

Components with workplace control parameters

Components	CAS-No.	Value type (Form of exposure)	Control parameters / Permissible concentration	Basis
WHITE MINERAL OIL	8042-47-5	REL	5 mg/m3 Mist.	NIOSH/GUID E
		STEL	10 mg/m3 Mist.	NIOSH/GUID E
		PEL	5 mg/m3 Mist.	OSHA_TRA NS
		TWA	5 mg/m3 Mist.	TN OEL
		TWA	5 mg/m3 Inhalable fraction.	ACGIH

Engineering measures : Provide sufficient mechanical (general and/or local exhaust) ventilation to maintain exposure below exposure guidelines (if applicable) or below levels that cause known, suspected or apparent adverse effects.

		Page: 6
		Revision Date: 07/31/2016
SAFETY DATA SHEET		Print Date: 11/1/2016
		SDS Number: R0300933
Synpower™ 75W-90 SYNTHETIC GEAR OIL		Version: 1.1
VV975		

Personal protective equipment

Hand protection

Remarks : The suitability for a specific workplace should be discussed with the producers of the protective gloves.

Eye protection

: Wear chemical splash goggles when there is the potential for exposure of the eyes to liquid, vapor or mist.

Skin and body protection

: Wear as appropriate:
 impervious clothing
 Safety shoes
 Choose body protection according to the amount and concentration of the dangerous substance at the work place.
 Discard gloves that show tears, pinholes, or signs of wear.
 Wear resistant gloves (consult your safety equipment supplier).

Hygiene measures

: Wash hands before breaks and at the end of workday.
 When using do not eat or drink.
 When using do not smoke.

SECTION 9. PHYSICAL AND CHEMICAL PROPERTIES

Physical state	: liquid
Odour	: mild
Odour Threshold	: No data available
pH	: No data available
Melting point/freezing point	: No data available
Boiling point/boiling range	: No data available
Flash point	: > 390 °F / > 199 °C Method: Cleveland open cup
Evaporation rate	: No data available
Flammability (solid, gas)	: No data available
Upper explosion limit	: 6 %(V) Calculated Explosive Limit
Lower explosion limit	: 1 %(V) Calculated Explosive Limit
Vapour pressure	: 1.3333333 hPa (20 °C) Calculated Vapor Pressure

		Page: 7
SAFETY DATA SHEET		Revision Date: 07/31/2016
		Print Date: 11/1/2016
		SDS Number: R0300933
Synpower™ 75W-90 SYNTHETIC GEAR OIL		Version: 1.1
VV975		

Relative vapour density	: No data available
Relative density	: No data available
Density	: 0.86 g/cm ³ (15.56 °C)
Solubility(ies)	
Water solubility	: No data available
Solubility in other solvents	: No data available
Partition coefficient: n-octanol/water	: No data available
Thermal decomposition	: No data available
Viscosity	
Viscosity, dynamic	: No data available
Viscosity, kinematic	: 100 mm ² /s (40 °C)
Oxidizing properties	: No data available

SECTION 10. STABILITY AND REACTIVITY

Reactivity	: No decomposition if stored and applied as directed.
Chemical stability	: Stable under recommended storage conditions.
Possibility of hazardous reactions	: Product will not undergo hazardous polymerization.
Conditions to avoid	: excessive heat Exposure to sunlight.
Incompatible materials	: Iron steel Strong acids Strong oxidizing agents
Hazardous decomposition products	carbon dioxide and carbon monoxide Hydrocarbons Hydrogen chloride gas Nitrogen oxides (NO _x) Oxides of phosphorus Sulphur oxides

		Page: 8
		Revision Date: 07/31/2016
SAFETY DATA SHEET		Print Date: 11/1/2016
		SDS Number: R0300933
Synpower™ 75W-90 SYNTHETIC GEAR OIL		Version: 1.1
VV975		

SECTION 11. TOXICOLOGICAL INFORMATION

Information on likely routes of exposure : Inhalation
Skin contact
Eye Contact
Ingestion

Acute toxicity

Not classified based on available information.

Components:**HEAVY PARAFFINIC DISTILLATE:**

Acute oral toxicity : LD 50 (Rat): > 15 g/kg

Acute dermal toxicity : LD 50 (Rabbit): > 5 g/kg

DI-TERT-BUTYL POLYSULFIDE:

Acute oral toxicity : LD50 (Rat): > 2,000 mg/kg
Method: OECD Test Guideline 401

Acute dermal toxicity : LD50 (Rat): > 2,000 mg/kg
Method: OECD Test Guideline 402

WHITE MINERAL OIL:

Acute oral toxicity : LD 50 (Rat): 50,000 mg/kg

Acute dermal toxicity : LD 50 (Rabbit): > 2,000 mg/kg
Assessment: Not classified as acutely toxic by dermal absorption under GHS.

Phosphoric acid esters, amine salt:

Acute oral toxicity : LD 50 (Rat): 2,000 mg/kg

Skin corrosion/irritation

Not classified based on available information.

Product:

Remarks: May cause skin irritation in susceptible persons.

Components:**HEAVY PARAFFINIC DISTILLATE:**

Result: Mildly irritating to skin

DI-TERT-BUTYL POLYSULFIDE:

Result: Slightly to moderately irritating to skin

WHITE MINERAL OIL:

Result: Not irritating to skin

Phosphoric acid esters, amine salt:

Result: Mildly irritating to skin

Serious eye damage/eye irritation

Causes serious eye irritation.

		Page: 9
		Revision Date: 07/31/2016
SAFETY DATA SHEET		Print Date: 11/1/2016
		SDS Number: R0300933
Synpower™ 75W-90 SYNTHETIC GEAR OIL		Version: 1.1
VV975		

Product:

Remarks: Vapours may cause irritation to the eyes, respiratory system and the skin., Causes serious eye irritation.

Components:

HEAVY PARAFFINIC DISTILLATE:

Result: Not irritating to eyes

DI-TERT-BUTYL POLYSULFIDE:

Result: Slightly irritating to eyes

WHITE MINERAL OIL:

Result: Not irritating to eyes

Phosphoric acid esters, amine salt:

Result: Severely irritating to eyes

Respiratory or skin sensitisation

Skin sensitisation: May cause an allergic skin reaction.

Respiratory sensitisation: Not classified based on available information.

Components:

DI-TERT-BUTYL POLYSULFIDE:

Test Type: Maximisation Test (GPMT)

Species: Guinea pig

Assessment: The product is a skin sensitiser, sub-category 1B.

Method: OECD Test Guideline 406

Phosphoric acid esters, amine salt:

Assessment: May cause sensitisation by skin contact.

Germ cell mutagenicity

Not classified based on available information.

Components:

DI-TERT-BUTYL POLYSULFIDE:

Genotoxicity in vitro : Test Type: in vitro assay

Result: Positive results were obtained in some in vitro tests.

Genotoxicity in vivo : Test Type: Micronucleus test

Test species: Mouse

Cell type: Bone marrow

Method: OECD Test Guideline 474

Result: negative

Carcinogenicity

Not classified based on available information.

Reproductive toxicity

Not classified based on available information.

STOT - single exposure

Not classified based on available information.

STOT - repeated exposure

Not classified based on available information.

Aspiration toxicity

Not classified based on available information.

		Page: 10
SAFETY DATA SHEET		Revision Date: 07/31/2016
		Print Date: 11/1/2016
		SDS Number: R0300933
Synpower™ 75W-90 SYNTHETIC GEAR OIL		Version: 1.1
VV975		

Components:

HEAVY PARAFFINIC DISTILLATE:

May be fatal if swallowed and enters airways.

Further information**Product:**

Remarks: No data available

Carcinogenicity:**IARC**

No component of this product present at levels greater than or equal to 0.1% is identified as probable, possible or confirmed human carcinogen by IARC.

OSHA

No component of this product present at levels greater than or equal to 0.1% is identified as a carcinogen or potential carcinogen by OSHA.

NTP

No component of this product present at levels greater than or equal to 0.1% is identified as a known or anticipated carcinogen by NTP.

SECTION 12. ECOLOGICAL INFORMATION**Ecotoxicity****Components:**

HEAVY PARAFFINIC DISTILLATE:

Toxicity to fish : LL50 (Fish): > 100 mg/l

Toxicity to daphnia and other aquatic invertebrates : EL50 (Aquatic invertebrates): > 10,000 mg/l

Toxicity to algae : EL50 (Algae, algal mat (Algae)): > 100 mg/l

Toxicity to fish (Chronic toxicity) : NOEC (Fish): 10 mg/l

Toxicity to daphnia and other aquatic invertebrates (Chronic toxicity) : NOEC (Aquatic invertebrates): 10 mg/l

DI-TERT-BUTYL POLYSULFIDE:

Toxicity to daphnia and other aquatic invertebrates : EC50 (Water flea (Daphnia magna)): 0.24 mg/l
Exposure time: 48 h
Test Type: static test
Method: OECD Test Guideline 202Toxicity to algae : EC50 (Pseudokirchneriella subcapitata (microalgae)): 2.45 mg/l
End point: Growth inhibition

		Page: 11
		Revision Date: 07/31/2016
SAFETY DATA SHEET		Print Date: 11/1/2016
		SDS Number: R0300933
Synpower™ 75W-90 SYNTHETIC GEAR OIL		Version: 1.1
VV975		

Exposure time: 72 h
 Test Type: static test
 Method: OECD Test Guideline 201

NOEC (Pseudokirchneriella subcapitata (microalgae)): 0.1 mg/l
 End point: Growth inhibition
 Exposure time: 72 h
 Test Type: static test
 Method: OECD Test Guideline 201

Phosphoric acid esters, amine salt:

Ecotoxicology Assessment

Acute aquatic toxicity : Toxic to aquatic life.

Chronic aquatic toxicity : Toxic to aquatic life with long lasting effects.

Persistence and degradability

Components:

DI-TERT-BUTYL POLYSULFIDE:

Biodegradability : Result: Not readily biodegradable.
 Biodegradation: 13 %
 Exposure time: 28 d
 Method: OECD Test Guideline 301B

Bioaccumulative potential

Components:

DI-TERT-BUTYL POLYSULFIDE:

Partition coefficient: n-octanol/water : log Pow: 5.6 (20 °C)
 pH: 7

Mobility in soil

Components:

No data available

Other adverse effects

No data available

Product:

Additional ecological information : An environmental hazard cannot be excluded in the event of unprofessional handling or disposal., Toxic to aquatic life with long lasting effects.

Components:

SECTION 13. DISPOSAL CONSIDERATIONS

Disposal methods

General advice : The product should not be allowed to enter drains, water

		Page: 12
SAFETY DATA SHEET		Revision Date: 07/31/2016
		Print Date: 11/1/2016
		SDS Number: R0300933
Synpower™ 75W-90 SYNTHETIC GEAR OIL		Version: 1.1
VV975		

courses or the soil.
Do not contaminate ponds, waterways or ditches with chemical or used container.
Send to a licensed waste management company.

Dispose of in accordance with all applicable local, state and federal regulations.

Contaminated packaging : Empty remaining contents.
Dispose of as unused product.
Empty containers should be taken to an approved waste handling site for recycling or disposal.
Do not re-use empty containers.

SECTION 14. TRANSPORT INFORMATION

International transport regulations

REGULATION

ID NUMBER	PROPER SHIPPING NAME	*HAZARD CLASS	SUBSIDIARY HAZARDS	PACKING GROUP	MARINE POLLUTANT / LTD. QTY.

U.S. DOT - ROAD

Not dangerous goods

CFR_RAIL_C

Not dangerous goods

U.S. DOT - INLAND WATERWAYS

Not dangerous goods

TDG_ROAD_C

Not dangerous goods

TDG_RAIL_C

Not dangerous goods

TDG_INWT_C

Not dangerous goods

INTERNATIONAL MARITIME DANGEROUS GOODS

		Page: 13
SAFETY DATA SHEET		Revision Date: 07/31/2016
		Print Date: 11/1/2016
		SDS Number: R0300933
Synpower™ 75W-90 SYNTHETIC GEAR OIL		Version: 1.1
VV975		

Not dangerous goods	MARINE POLLUTANT:(DI-TERT- BUTYL POLYSULFID E)
---------------------	--

INTERNATIONAL AIR TRANSPORT ASSOCIATION - CARGO

Not dangerous goods

INTERNATIONAL AIR TRANSPORT ASSOCIATION - PASSENGER

Not dangerous goods

MX_DG

Not dangerous goods

*ORM = ORM-D, CBL = COMBUSTIBLE LIQUID

Marine pollutant	yes
------------------	-----

Dangerous goods descriptions (if indicated above) may not reflect quantity, end-use or region-specific exceptions that can be applied. Consult shipping documents for descriptions that are specific to the shipment.

SECTION 15. REGULATORY INFORMATION

SARA 311/312 Hazards : Acute Health Hazard

SARA 313 Component(s) : This material does not contain any chemical components with known CAS numbers that exceed the threshold (De Minimis) reporting levels established by SARA Title III, Section 313.

Pennsylvania Right To Know

HEAVY PARAFFINIC DISTILLATE	64742-54-7	50.00 - 70.00 %
VISCOSITY MODIFIER	Not Assigned	20.00 - 30.00 %
DI-TERT-BUTYL POLYSULFIDE	68937-96-2	1.00 - 5.00 %
WHITE MINERAL OIL	8042-47-5	1.00 - 5.00 %

New Jersey Right To Know

HEAVY PARAFFINIC DISTILLATE	64742-54-7	50.00 - 70.00 %
-----------------------------	------------	-----------------

		Page: 14
SAFETY DATA SHEET		Revision Date: 07/31/2016
		Print Date: 11/1/2016
		SDS Number: R0300933
Synpower™ 75W-90 SYNTHETIC GEAR OIL		Version: 1.1
VV975		

VISCOSITY MODIFIER	Not Assigned	20.00 - 30.00 %
DI-TERT-BUTYL POLYSULFIDE	68937-96-2	1.00 - 5.00 %
WHITE MINERAL OIL	8042-47-5	1.00 - 5.00 %
LUBRICANT ADDITIVE	Not Assigned	1.00 - 5.00 %

California Prop 65

Proposition 65 warnings are not required for this product based on the results of a risk assessment.

The components of this product are reported in the following inventories:

TSCA	: On TSCA Inventory
DSL	: All components of this product are on the Canadian DSL.
AUSTR	: On the inventory, or in compliance with the inventory
NZIOC	: Not in compliance with the inventory
ENCS	: On the inventory, or in compliance with the inventory
KECL	: On the inventory, or in compliance with the inventory
PICCS	: On the inventory, or in compliance with the inventory
IECSC	: On the inventory, or in compliance with the inventory

Inventories

AICS (Australia), DSL (Canada), IECSC (China), REACH (European Union), ENCS (Japan), ISHL (Japan), KECL (Korea), NZIoC (New Zealand), PICCS (Philippines), TSCA (USA)

		Page: 15
		Revision Date: 07/31/2016
SAFETY DATA SHEET		Print Date: 11/1/2016
		SDS Number: R0300933
Synpower™ 75W-90 SYNTHETIC GEAR OIL		Version: 1.1
VV975		

SECTION 16. OTHER INFORMATION

Further information

Revision Date: 07/31/2016

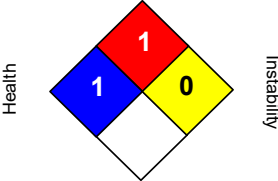
NFPA:	HMIS III:						
<p>Flammability</p>  <p>Health</p> <p>Instability</p> <p>Special hazard.</p>	<table border="1"> <tr> <td>HEALTH</td> <td>2</td> </tr> <tr> <td>FLAMMABILITY</td> <td>1</td> </tr> <tr> <td>PHYSICAL HAZARD</td> <td></td> </tr> </table> <p>0 = not significant, 1 = Slight, 2 = Moderate, 3 = High 4 = Extreme, * = Chronic</p>	HEALTH	2	FLAMMABILITY	1	PHYSICAL HAZARD	
HEALTH	2						
FLAMMABILITY	1						
PHYSICAL HAZARD							

NFPA Flammable and Combustible Liquids Classification

Combustible Liquid Class IIIB

Full text of H-Statements referred to under sections 2 and 3.

H227	Combustible liquid.
H302	Harmful if swallowed.
H304	May be fatal if swallowed and enters airways.
H317	May cause an allergic skin reaction.
H318	Causes serious eye damage.
H401	Toxic to aquatic life.
H411	Toxic to aquatic life with long lasting effects.

Sources of key data used to compile the Safety Data Sheet

Valvoline internal data including own and sponsored test reports

The UNECE administers regional agreements implementing harmonised classification for labelling (GHS) and transport.

The information accumulated herein is believed to be accurate but is not warranted to be whether originating with the company or not. Recipients are advised to confirm in advance of need that the information is current, applicable, and suitable to their circumstances. This SDS has been prepared by Valvoline's Environmental Health and Safety Department (1-800-825-8654).

List of abbreviations and acronyms that could be, but not necessarily are, used in this safety data sheet :

ACGIH : American Conference of Industrial Hygienists

BEI : Biological Exposure Index

		Page: 16
SAFETY DATA SHEET		Revision Date: 07/31/2016
		Print Date: 11/1/2016
		SDS Number: R0300933
Synpower™ 75W-90 SYNTHETIC GEAR OIL		Version: 1.1
VV975		

CAS : Chemical Abstracts Service (Division of the American Chemical Society).
 CMR : Carcinogenic, Mutagenic or Toxic for Reproduction
 FG : Food grade
 GHS : Globally Harmonized System of Classification and Labeling of Chemicals.
 H-statement : Hazard Statement
 IATA : International Air Transport Association.
 IATA-DGR : Dangerous Goods Regulation by the "International Air Transport Association" (IATA).

ICAO : International Civil Aviation Organization
 ICAO-TI (ICAO) : Technical Instructions by the "International Civil Aviation Organization"
 IMDG : International Maritime Code for Dangerous Goods
 ISO : International Organization for Standardization
 logPow : octanol-water partition coefficient
 LCxx : Lethal Concentration, for xx percent of test population
 LDxx : Lethal Dose, for xx percent of test population.
 ICxx : Inhibitory Concentration for xx of a substance
 Ecxx : Effective Concentration of xx
 N.O.S.: Not Otherwise Specified
 OECD : Organization for Economic Co-operation and Development
 OEL : Occupational Exposure Limit
 P-Statement : Precautionary Statement
 PBT : Persistent , Bioaccumulative and Toxic
 PPE : Personal Protective Equipment
 STEL : Short-term exposure limit
 STOT : Specific Target Organ Toxicity
 TLV : Threshold Limit Value
 TWA : Time-weighted average
 vPvB : Very Persistent and Very Bioaccumulative
 WEL : Workplace Exposure Level

CERCLA : Comprehensive Environmental Response, Compensation, and Liability Act
 DOT : Department of Transportation
 FIFRA : Federal Insecticide, Fungicide, and Rodenticide Act
 HMIRC : Hazardous Materials Information Review Commission
 HMIS : Hazardous Materials Identification System
 NFPA : National Fire Protection Association
 NIOSH : National Institute for Occupational Safety and Health
 OSHA : Occupational Safety and Health Administration
 PMRA : Health Canada Pest Management Regulatory Agency
 RTK : Right to Know
 WHMIS : Workplace Hazardous Materials Information System

[Oct/31/2014][1/7]

[MOLYWHITE RE No.00][KYODO YUSHI CO., LTD.][07-543]

SAFETY DATA SHEET**1. Identification**Product identifier: **MOLYWHITE RE No.00**Recommended use of the chemical and restrictions on use:
Lubricating grease

Manufacturer

Name: KYODO YUSHI CO., LTD.

Address: 2-2-30, Tsujido Kandai, Fujisawa-Shi, Kanagawa, Japan

TEL: +81-466-33-3157

Emergency phone number: +81-466-33-3157

2. Hazards identification

GHS Classification

Physical Hazards

Flammable liquids : Not classified

Health Hazards

Acute toxicity - Oral : Not classified

Acute toxicity - Dermal : Not classified

Environment Hazards

Hazardous to the aquatic environment (Long-term hazard)
: Category Chronic 3OSHA Defined Hazards: (Pyrophoric gas, Simple asphyxiant,
Combustible dust)
: Classification not possible

GHS Labeling Elements

Symbol: Not applicable.

Signal Word: Not applicable.

Hazard Statements:

(H412) Harmful to aquatic life with long lasting effects

Precautionary Statements

Prevention:

(P273) Avoid release to the environment.

Response:

Not applicable.

Storage:

Not applicable.

Disposal:

(P501) Disposal should be in accordance with applicable
regional, national and local laws and regulations.

Hazards Not Otherwise Classified(HNOC)

• Not applicable.

3. Composition/ information on ingredients

Formula: Not applicable.

[Oct/31/2014][2/7]

[MOLYWHITE RE No.00][KYODO YUSHI CO., LTD.][07-543]

Components:

Component	Contents(%)
Base oil(Synthetic hydrocarbon oil, refined mineral oil)	85-95
Thickener(Lithium soap)	< 10
EP additive(Containing molybdenum compounds,	< 5
Oxidation inhibitor(Butylated hydroxytoluene (BHT))	< 5
Additive(s)(Containing barium compounds)	< 5

Hazardous Ingredients:

Component	CAS No.	Contents(%)
Molybdenum compounds	Confidential	1-3

See Section 8 for exposure limits (if applicable).

See Section 15 for legal controlled substance (if applicable).

4. First-aid measures

Eye Contact:

- Immediately flush with water for at least 15 minutes. Get medical attention.

Skin Contact:

- Thoroughly remove with cloth or paper and wash carefully with soap and water.

Inhalation:

- Remove the victim from the contamination to fresh air. Cover the victim in a blanket to keep warm and quiet. Consult a physician.

Ingestion:

- Do not induce vomiting. Immediate consult a physician.

Notes to Physicians:

- Supportive care. Treatment based on judgment of the physician in response to reactions of the patient.

5. Fire-fighting measures

Flammable Limits: No data available.

Autoignition Temperature: No data available.

Extinguishing Media:

- Foam, dry chemical, CO₂, dry sand.

Unsuitable Extinguishing Media:

- Do not use water. Water can be dangerous possibly leading to fire spread.

Specific Hazards with Regard to Fire-fighting:

- Thermal decomposition and combustion may produce carbon monoxide and/or carbon dioxide.

Specific Methods of Fire-fighting:

- In the early stages of fire, use dry chemical, CO₂, dry sand, etc. fire-extinguisher.
- In case of massive fire, use foam fire-extinguisher to shut off the air supply.
- Get all persons to safety. Authorized personnel only at the fire site.

Protection of Firefighters:

- Fire-fighters should wear protective equipment.
- Start fire fighting from the windward side.

[Oct/31/2014][3/7]

[MOLYWHITE RE No.00][KYODO YUSHI CO., LTD.][07-543]

6. Accidental release measures

Personal Precautions:

- Wear protective equipment during cleanup work.

Environmental Precautions:

- Prevent spills from entering sewers or waterway.

Methods for Clean-Up:

- For small spills, absorb with inert material (e.g., dry sand, sawdust or waste cloth), then place in a chemical waste container with a cover for disposal.
- For large spills, dike to keep spillage in a safe place for later disposal.

Prevention of Secondary Hazards:

- Immediately shut off all sources of ignition.

7. Handling and storage

Handling

Technical Measures:

- Handle the product in a well-ventilated place. Do not leak, flood or scatter the product to prevent unwanted evaporation.

Precautions:

- Contact with eye may cause irritation. Use protective glasses to avoid contact with eyes.
- Contact with skin may cause irritation. Use protective gloves to avoid skin contact.
- Do not swallow. (Drinking the product may cause diarrhea and vomiting.)
- Close container after each use.

Precautions for Safe Handling:

- Wear gloves to avoid injury on hands at opening the container.

Storage

Appropriate Storage Conditions:

- Keep container closed to protect from dust/water ingress after use.
- Store in a cool, dry place, away from direct sunlight, heat source and fire.
- Keep out of reach of children.

Safe Packaging Materials:

- Do not expose empty container to pressure.
- Do not weld, heat, drill or cut container. Residue ignition and explosion hazards.

8. Exposure controls/personal protection

Exposure Guidelines

ACGIH

- Butylated hydroxytoluene (BHT): TWA 2mg/m³
- Mineral oil: TWA 5mg/m³

Engineering Controls:

- When vapor or mist exhales, install an apparatus to close the vapor/mist source or ventilation equipment.

Protective Equipment

Respiratory Protection:

- Wear a gas mask for organic gas when needed (not necessary under normal conditions).

[Oct/31/2014][4/7]

[MOLYWHITE RE No.00][KYODO YUSHI CO., LTD.][07-543]

Hand Protection:

- Wear oil-resistant protective gloves in case of prolonged and/or repeated skin contact.

Eye Protection:

- Wear chemical safety goggles whenever the product splashes.

Skin and Body Protection:

- Wear long-sleeved oil-resistant working clothes whenever handling for many hours and/or getting wet. Immediately take off the wet clothes and thoroughly wash them before reusing.

9. Physical and chemical properties

Appearance

Form	: Semi-fluid
Color	: Yellow
Odor	: Slight odor
pH	: No data available.
Melting point	: No data available.
Flash point	: 190°C(Seta)
Vapor pressure	: No data available.
Solubility in water	: Insoluble in water
Vapor density	: No data available.
Density	: 0.87(25°C)g/cm ³
Partition coefficient: n-octanol/water	: No data available.
Viscosity	: No data available.
Dropping point	: 193°C

10. Stability and reactivity

Reactivity, Conditions to avoid:

- Avoid contact with strong oxidant.

Chemical Stability:

- Product is stable under normal conditions.

Possibility of Hazardous Reactions:

- Not available.

Materials to avoid:

- Strong oxidizers.

Hazardous Decomposition Products:

- This material is expected to be stable under normal conditions of use.

11. Toxicological information

Information on the likely routes of exposure: Not applicable.

Delayed and immediate effects and also chronic effects from short- and long-term exposure

Acute toxicity - Oral:

- Not classified based on the category of each ingredient or the product properties.
- Refined mineral oil LD50 Acute oral >5 g/kg (rat)

Acute toxicity - Dermal:

- Not classified based on the category of each ingredient or the product properties.

Acute toxicity - Inhalation (Gases): No data available.

Acute toxicity - Inhalation (Vapors): No data available.

Acute toxicity - Inhalation (Dusts and mists): No data available.

Skin corrosion/irritation: No data available.

[Oct/31/2014][5/7]

[MOLYWHITE RE No.00][KYODO YUSHI CO., LTD.][07-543]

Eye damage/irritation: No data available.
Sensitization - Respiratory: No data available.
Sensitization - Skin: No data available.
Germ cell mutagenicity: No data available.
Carcinogenicity: No data available.
Toxic to reproduction: No data available.
Effects on or via lactation: No data available.
Specific target organ toxicity (Single exposure):
 No data available.
Specific target organ toxicity (Repeated exposure):
 No data available.
Aspiration hazard: No data available.
Other Toxicity Information
NTP Report on Carcinogens: Not listed.
IARC Monographs: Not listed.

12. Ecological information

Ecotoxicity
Hazardous to the aquatic environment (Acute hazard):
 No data available.
Hazardous to the aquatic environment (Long-term hazard):
 • Classified under Category Chronic 3 based on the category of
 each ingredient or the product properties.
Persistence and Degradability: No data available.
Bioaccumulative potential: No data available.
Mobility in soil: No data available.
Hazardous to the ozone layer: No data available.

13. Disposal considerations

Waste Residues:
 • Properly dispose of in accordance with any relevant regulations.
 • Properly dispose of by a licensed waste disposer.
 • For in-house incineration disposal, ensure exhaust gas treatment
 (washing treatment, etc.) to prevent air pollution from sulfur
 oxides.
 • No dumping.
 • When burning, be sure to do so on someone's watch in a safe
 place and in the way that burning and/or explosion will never
 pose a potential hazard.
Contaminated Packaging:
 • Dispose of container after completely removing the contents.

14. Transport information

DOT Hazardous Materials: Not applicable.
UN Transport of Dangerous Goods
UN Number: Not applicable.
UN Proper Shipping Name: Not applicable.
Transport Hazard Class: Not applicable.
Packing Group: Not applicable.
Land(RID/ADR): Not applicable.
Sea(IMO/IMDG): Not applicable.
Air(ICAO/IATA): Not applicable.
Specific Precautionary Transport Measures and Conditions:
 • Contains combustible liquid. Keep fire away.
 • Handle with care to prevent container damage.

[Oct/31/2014][6/7]

[MOLYWHITE RE No.00][KYODO YUSHI CO., LTD.][07-543]

- Ensure proper packaging before shipping to avoid load shifting and falling accident.

15. Regulatory information

Regulatory information with regard to this product in your country or your region should be examined by your own responsibility.

US TSCA (Toxic Substances Control Act)

All components of this product are listed on the TSCA inventory of Chemical Substances.

US OSHA (Occupational Safety and Health Act):

This product is hazardous according to the OSHA Hazard Communication Standard, 29 CFR 1910.1200, since this product contains OSHA Hazardous Substances;

Name	CAS No.	Contents(%)
Molybdenum compounds	Confidential	1-3

US CERCLA

(Comprehensive Environmental Release, Compensation & Liability Act):

CERCLA Hazardous Substances:

Name	CAS No.	Contents(%)
Zinc compounds	Confidential	0.1-0.5

US SARA (Superfund Amendment & Reauthorization Act) Title III:

SARA Extremely Hazardous Substances (302): None

SARA Hazard Categories (311/312): None

SARA Toxic Release Inventory (TRI) (313):

Name	CAS No.	Contents(%)
Barium compounds	Confidential	0.3-0.7
Zinc compounds	Confidential	0.1-0.5

16. Other Information

NFPA

Health hazards: 1
 Flammability: 1
 Instability: 0
 Special Hazard: -

Contact Information

Name: KYODO YUSHI CO., LTD.
 International Business Dept.
 Address: 2-2-30, Tsujido Kandai, Fujisawa-Shi, Kanagawa, Japan
 TEL: +81-466-33-3157

Name: KYODO YUSHI USA INC.
 Address: Continental Towers - Tower I, 1701 Golf Road, Suite 1108
 Rolling Meadows 60008 IL, U.S.A.
 TEL: +1-847-364-2020
 E-mail: info@kyodoyushiusa.com

[Oct/31/2014][7/7]

[MOLYWHITE RE No.00][KYODO YUSHI CO., LTD.][07-543]

Original date: Oct/31/2014

Revision date: / /

References

- 1.OSHA Hazard Communication Standard 29 CFR 1910.1200
- 2.Thresholds limit values for chemical substances and physical agents and biological exposure indices, ACGIH(2012)
- 3.IARC MONOGRAPHS ON THE EVALUATION OF THE CARCINOGENIC RISK OF CHEMICALS TO HUMANS VOLUME 33
- 4.Report on Carcinogens Twelfth Edition 2011, NTP
- 5.EU CLP Regulation (EC No 1272/2008 ANNEX VI Harmonised classification and labelling for certain hazardous substances)
- 6.Globally Harmonized System of Classification and Labelling of Chemicals (GHS) Third revised edition.

Disclaimer

This SDS is an addition and complementary document beside the technical data sheet.The information is based upon our knowledge about the product at the date of edition.

Since we cannot anticipate or control the different conditions under which these information or our product may be used, we make no guarantee that recommendations will be adequate for all individuals and situations.