

# ROTTLER

## F107AHL / F109AHL EXTRA HEAVY DUTY CNC MACHINING CENTER

OPERATION AND MAINTENANCE MANUAL







# **MANUAL SECTIONS**

**INTRODUCTION**

**INSTALLATION**

**SAFETY**

**CONTROL DEFINITIONS**

**OPERATING INSTRUCTIONS**

**MAINTENANCE**

**TROUBLESHOOTING**

**MACHINE PARTS**

**OPTIONS**

**MSDS**

## **ORDERING PROCEDURE**

Contact your regional Rottler sales rep for assistance in ordering optional equipment, replacement parts, or tooling.

If you are unable to contact your regional Rottler sales rep, call the factory at 253-872-7050 and ask to speak to the parts sales specialist.

Have the following information handy to expedite the ordering process:

1. Your name, business name, and contact number
2. Customer number
3. If you don't have a customer number, your billing address
4. Shipping address if different from billing address
5. Machine model and serial number
6. Part number and description of what you want to order
7. Preferred method of shipment
8. You may also contact us via e-mail with the above information. Send e-mail requests to: [parts@rottlermfg.com](mailto:parts@rottlermfg.com)

In some cases you may be requested to send a photo of the part you are ordering if it is a replacement part, or doesn't appear in the database.

If you are unsure which part you need to order, contact our service department and ask to speak to one of our service consultants. They will assist you in determining which part you require.

**THERE IS A MINIMUM ORDER OF \$25.00**



# **INTRODUCTION**

## **Contents**

<b>Introduction.....</b>	<b>1-1</b>
<b>Description.....</b>	<b>1-2</b>
<b>Disclaimer .....</b>	<b>1-2</b>
<b>Limited Warranty .....</b>	<b>1-3</b>
<b>Online Documentation Access.....</b>	<b>1-4</b>

## Introduction

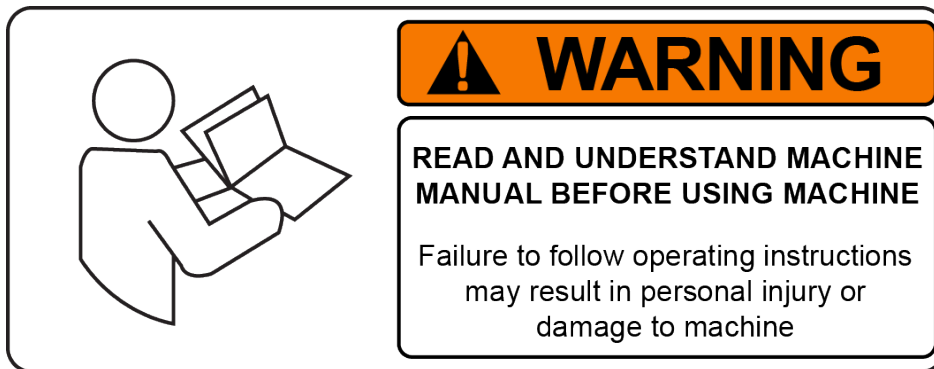

**READ THE SAFETY CHAPTER BEFORE INSTALLING MACHINE. THOROUGHLY UNDERSTAND ALL SAFETY ISSUES BEFORE OPERATING MACHINE.**

### **ATTENTION OWNER/BUSINESS MANAGER**

**To validate the warranty on your new Rottler machine, please be sure to sign and complete the “Installation Report” located in the Installation Chapter of this manual.**

We suggest that the new user of the F107/9AHL read the CONTROL DEFINITIONS to get an idea how the machine operates.

The Operating Instructions chapter should be read in order to familiarize the user with the actual button pushing sequences required to carry out a job. These chapters in the manual should be considered an introduction. As the operators of the F107/9AHL series machines gain experience with using the different functions of the machine, complicated setups and programs will make more sense.

The rest of the manual contains information and part number reference on fixtures, cutting tools, and machine maintenance. The operator should read and become familiar with these areas as well.

## Description

The model F107/9AHL machine is a precision, single point boring, and high-speed surfacing unit. The machine can be equipped with tooling and accessories for surfacing and re-boring most American passenger car and truck engines, In-lines, as well as 90 and 60 degree V-types.

F107/9AHL machines can be easily tooled, to machine a wide range of engines, including European and Asian engines, also, the machine can be easily adapted to perform other boring and surfacing operations.

The machine is designed, to maintain alignment of cylinder bores, and cylinder head, deck surfaces to the pan rails and main bearing bore locations, as was done in the original factory machining. This overcomes the many inaccuracies and out-of-alignment problems associated with clamping portable boring bars to the cylinder head surface of blocks.

Convenient controls, fast block clamping, precise 3 axis CNC positioning and clamping, means considerable savings in floor to floor time, and operator involvement.

Change over or resetting time required to set up V-type or in-line engines is a minimum, making this machine highly suited to the jobber shop where engines cannot be run through in model lots.

All feeds and rapid travels are power operated and controlled from the control panel.

## Disclaimer

The F107/9AHL Manual (henceforth to be referred to as the "Manual") is proprietary to Rottler Manufacturing LLC. ("Rottler Manufacturing") and no ownership rights are hereby transferred. No part of the Manual shall be used, reproduced, translated, converted, adapted, stored in a retrieval system, communicated or transmitted by any means, for any commercial purpose, including without limitation, sale, resale, license, rental or lease, without the prior express written consent of Rottler Manufacturing.

Rottler Manufacturing does not make any representations, warranties or guarantees, express or implied, as to the accuracy or completeness of the Manual. Users must be aware that updates and amendments will be made from time to time to the Manual. It is the user's responsibility to determine whether there have been any such updates or amendments. Neither Rottler Manufacturing nor any of its directors, officers, employees or agents shall not be liable in any manner whatsoever to any person for any loss, damage, injury, liability, cost or expense of any nature, including without limitation incidental, special, direct or consequential damages arising out of or in connection with the use of the Manual.

Rottler Manufacturing and its employees or representatives are not responsible for any information regarding final specifications of any workpiece that is created as a final product when using Rottler equipment. It is the responsibility of the end user of Rottler equipment to determine the final dimensions and finishes of the workpiece that they are working on. Any information regarding final dimensions and finishes that appears in any Rottler literature or that is expressed by anyone representing Rottler is to be regarded as general information to help with the demonstration of or for operator training of Rottler equipment.

## Limited Warranty

Rottler Manufacturing Company Model F107/9AHL parts and equipment is warranted as to materials and workmanship. This limited warranty remains in effect for one year from the date of installation or two years from the date of the original shipment from Rottler or whichever date occurs first. This only applies if the machine is owned and operated by the original purchaser and is operated and maintained as per the instructions in the manual. A machine is warranted only if the Installation Report has been properly executed by a certified installation person and received by Rottler at the time of actual installation.

The products are warranted upon delivery to conform to their published specifications and to be free from defects in material and workmanship under normal use for a period of one year from shipment. Should a product not be as warranted, Rottler sole obligation shall be, at its option, to repair, correct or replace the product or to refund the amounts paid for the Product upon its return to a location designated by Rottler. No warranty shall extend to rapid wear Products (including tooling) or to Products which have been subject to misuse (including any use contrary to Rottler instructions), neglect, accident (including during shipment), improper handling or installation, or subject to any modification, repair or service not certified by Rottler. Rottler shall not be liable for any consequential, direct or indirect damages or for any other injury or loss. Buyer waives any right, beyond the foregoing warranty, to make a claim against Rottler. No warranty is provided for any products not paid in full.

Merchandise cannot be returned to Rottler without prior approval. Customer must contact the Order Department or representative to get approval and to be issued a Return Goods Authorization number (RGR#). Merchandise authorized for return must be returned prepaid. If merchandise is returned with shipping charges collect, the actual amount of these charges may be deducted from any credit which may be due the customer. The RGR # assigned by the Order Department should be written on the shipping label and must appear on a copy of the invoice(s) covering the original shipment. This invoice copy must be included in the box with the parts. Shipment must contain ONLY those items on the RGR as approved for return. Merchandise must be received within 10 days of the date of RGR or the RGR will be canceled. All returned merchandise may be subject to a 20% restocking fee on under \$1,000.00 amount or 10% on any items over \$1,000.00. Parts or tooling over 30 days old are considered as customer property and can only be returned with prior written approval from Rottler Corporation Management and/or Shipping Department.

***The issuance of a RGR DOES NOT guarantee credit*** - it is only authorization for the return of the goods. Credit for return merchandise is at the sole discretion of Rottler. Credit will be issued only after inspection of returned goods.

Tools proven to be defective within the warranty period will be repaired or replaced at the factory's option. We accept no responsibility for defects caused by external damage, wear, abuse, or misuse, nor do we accept any obligation to provide compensation for direct or indirect costs in connection with cases covered by the warranty.



## Online Documentation Access

Online documentation for machines and optional equipment can be accessed at the Rottler website. To access documentation open your browser and navigate to <https://www.rottlermfg.com>.

Scroll to the bottom of the page and under the Owner Resources title click the type of documentation you want to access.

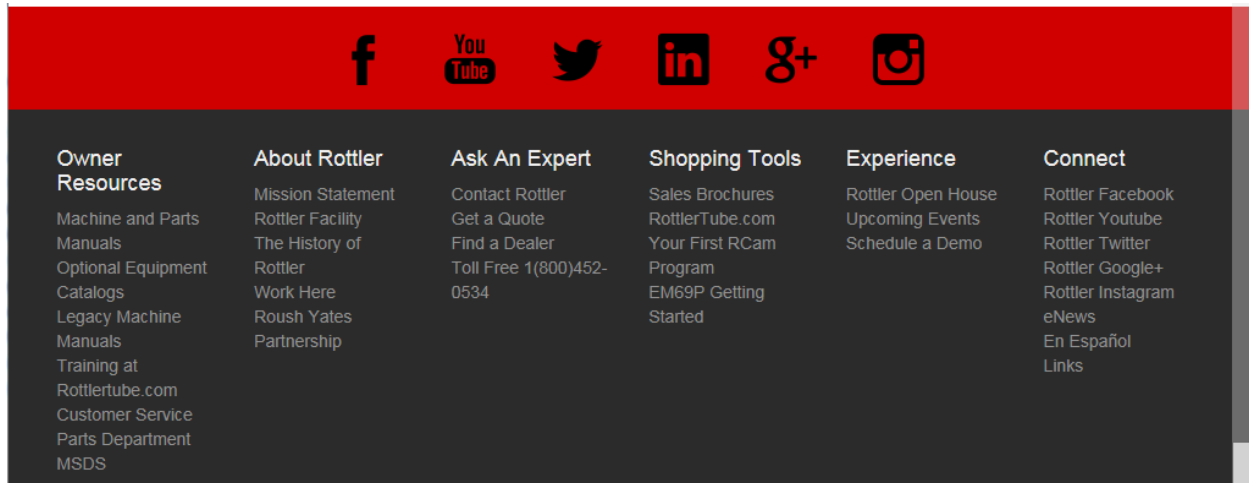

If a log in window pops up asking for user name and password fill in the blanks as shown.

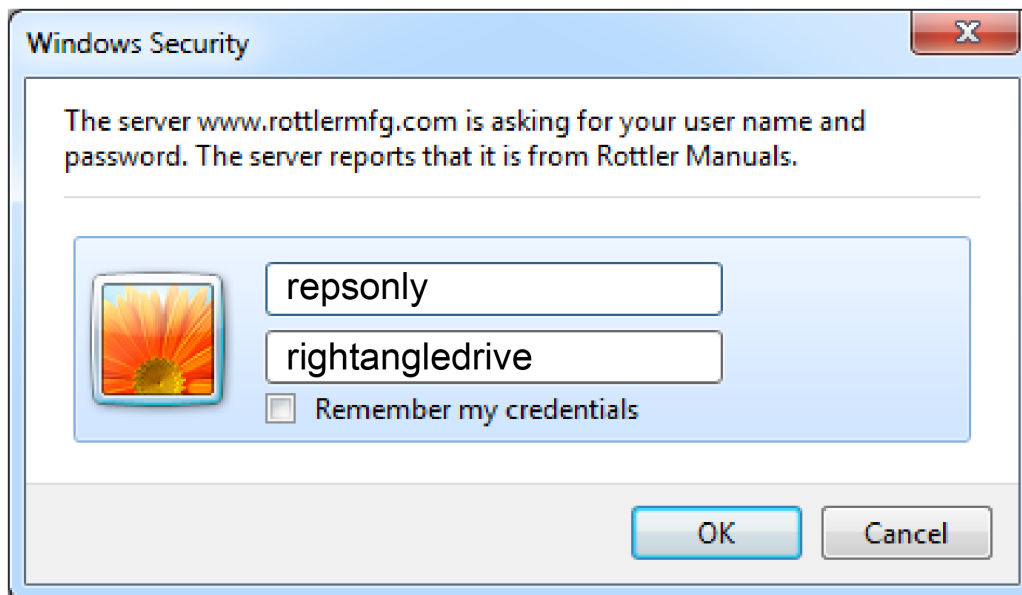

This page intentionally left blank

# INSTALLATION

## Contents

<b>F107/109 PRE INSTALLATION REQUIREMENTS .....</b>	<b>2-1</b>
<b>F100 SERIES INSTALLATION REPORT .....</b>	<b>2-3</b>
<b>Removing Machine from Shipping Container.....</b>	<b>2-11</b>
<b>Methods of Lifting Machine Components .....</b>	<b>2-13</b>
<b>Machine Bed .....</b>	<b>2-13</b>
<b>Machine Table .....</b>	<b>2-14</b>
<b>Column and Spindle Assembly .....</b>	<b>2-15</b>
<b>Installation Procedure.....</b>	<b>2-16</b>
<b>Rottler F107/9 Series Foundation and Hold Install Procedure.....</b>	<b>2-16</b>
<b>F107 Hold Down and Jacking Bolt Locations.....</b>	<b>2-18</b>
<b>F109 Hold Down and Jacking Bolt Locations.....</b>	<b>2-20</b>
<b>Machine Dimensions.....</b>	<b>2-21</b>
<b>Front View.....</b>	<b>2-21</b>
<b>Left Side View.....</b>	<b>2-22</b>
<b>Location .....</b>	<b>2-23</b>
<b>Unpacking.....</b>	<b>2-23</b>
<b>Column Hold Down.....</b>	<b>2-23</b>
<b>Leveling .....</b>	<b>2-23</b>
<b>Air Supply.....</b>	<b>2-24</b>
<b>Power Supply.....</b>	<b>2-25</b>
<b>Grounding.....</b>	<b>2-25</b>
<b>Creating a Skype Account.....</b>	<b>2-26</b>

## **F107/109 PRE INSTALLATION REQUIREMENTS**

1. Remove all fixtures, boxes, and any items packed for shipment, etc. from the table, and slide way casting.
2. Mark the floor where each anchor stud will be located. The suggested method is putting the castings in place and marking the holes, for accurate placement. Remove the castings, and drill the holes for the anchor studs. Epoxy, and install the studs. (Castings may be set back in place, and used as a guide for installing the studs)
3. If a forklift will be used to install the column, and work head on the machine, do not install the 2 front, center, anchor studs for the table. The holes can be drilled, but do not install. Ensure the nuts for the anchor studs spin freely and that there is no thread damage.
4. After the anchor studs are epoxied and set, remove the table and temporarily set aside.
5. Place a leveling pad under each jacking bolt, and level the slide way casting as close as possible. Finish leveling will be done by the Rottler technician using a laser.
6. Decide on the best method of lifting the column, and work head, and have the equipment ready. Forklift or overhead crane. A Rottler technician will install the column, and work head.
7. Have the electrical and air supplies connected, and ready to switch on. 208-240 volts and approx. 100 PSI of clean, dry air
8. Clean all rust preventative from the machine, fixtures, and way covers. Mineral spirits works well to dissolve the cosmollne/rust preventative.
9. Machine requires an Internet connection. Preferably wireless.

## **ATTENTION OWNER/BUSINESS MANAGER**

**To validate the warranty on your new Rottler machine, please be sure to sign the installation report after the installation technician has installed the machine and verified the machine is operating correctly and given the operators operation and maintenance training.**

**Thank you for your cooperation and the opportunity to be of service to you.**

***ROTTLER MANUFACTURING***



OFFICE USE ONLY  
Route to: Servicer Mgr → Accounting → Andy → Accounting Warranty Exp Date \_\_\_\_\_

**ROTTLER MANUFACTURING MUST HAVE THIS REPORT RETURNED TO PROPERLY QUALIFY WARRANTY ON EQUIPMENT**

Customer: \_\_\_\_\_ Address: \_\_\_\_\_  
City: \_\_\_\_\_ State: \_\_\_\_\_ Zip: \_\_\_\_\_ Phone: \_\_\_\_\_  
Country: \_\_\_\_\_  
Machine Model: \_\_\_\_\_ Serial Number: \_\_\_\_\_ Representative: \_\_\_\_\_

**MACHINE INSTALLATION:** Electrical information MUST be complete to validate this report.

\_\_\_\_\_ Customer has read and fully understands importance of machine location as explained in the installation section of the manual.

**The following is the customer’s responsibility prior to the arrival of Rottler technician. Please initial each item when it is completed.**

*Customer must provide foundation and hold down bolt system, see following attached drawing and document “F70 and F100 Series Foundation and Hold Down Requirements”*



**VERY IMPORTANT:** Modern design machines contain electronic low voltage circuitry that provides great advantages and a better machine life. BUT, you must have an excellent, stable, isolated power supply along with an isolated ground. If not, electrical noise problems are likely to interfere with machine operation unexpectedly.

**Customer is responsible for providing electricity to machine in a manner that meets the local electrical code requirements.**

- \_\_\_\_\_ Remove machine from truck. Weight: F103 14,000 lbs (6,350 kg) F104 16,000 lbs (7257 kg) F105 18,000 lbs (8165 kg) F107 45,000 lbs (20,412 kg) F109 50,000 lbs (22680 kg).
- \_\_\_\_\_ If machine was shipped in a container follow the procedure for removing machine located in the installation section of the manual.
- \_\_\_\_\_ Remove fixturing and misc. parts from machine and clean.
- \_\_\_\_\_ Install machine on foundation with supplied jack pads under jacking bolts.
- \_\_\_\_\_ Install hold down nuts and bolts, see attached document. – This must e done first.
- \_\_\_\_\_ Rough Level the machine using a precision level so there is equal tension on all bolts.
- \_\_\_\_\_ This machine requires between 208 and 240 Volts AC, Three Phase, 50/60 Hz, isolated power supply. For voltages above 240 or below 208 VAC, a 17kva transformer will be required and is available at Rottler. Please specify voltage when ordering. Measure the incoming voltage between L1 and L2, L2 and L3, and L1 and L3. Current requirements for this machine is 60 amps. Measure the incoming AC voltage at least twice during installation.
  1. L1to L2 \_\_\_\_\_ VAC, L2 to L3 \_\_\_\_\_ VAC, L1 to L3 \_\_\_\_\_
  2. L1to L2 \_\_\_\_\_ VAC, L2 to L3 \_\_\_\_\_ VAC, L1 to L3 \_\_\_\_\_



\_\_\_\_\_ Measure each leg of the incoming supply to ground. Sometimes you may find a “high” leg to ground. When this happens make sure the high leg is running to L3.  
 L1 to ground \_\_\_\_\_ VAC L2 to ground \_\_\_\_\_ VAC L3 to ground \_\_\_\_\_ VAC

**CAUTION**

Neutral and machine ground are not the same thing. You should measure an open circuit between Neutral and ground.

**CAUTION**

**IF VOLTAGE IS OUTSIDE THE CORRECT RANGE AT ANY TIME THE MACHINE WILL NOT OPERATE PROPERLY AND MAY BE DAMAGED.**

- \_\_\_\_\_ Air of the proper pressure and capacity connected to the machine. Air supply must be free from oil and water. Oil or water will damage electrical and air components.
- \_\_\_\_\_ Customer should attempt to have junk work piece available.
- \_\_\_\_\_ Have the operator read through the operation manual before training begins. This will help him be familiar with the button pushing sequences. Have the operator read through the manual again after training and some of the sequences will make more sense.
- \_\_\_\_\_ Have Internet connection available for the machine. Either via Ethernet cable or Wireless. The machine comes equipped with a wireless USB adapter.

## The following is the Rottler technician’s responsibility

- \_\_\_\_\_ Check column top and spindle base bottom for rust and nicks if spindle must be installed. Clean and stone as required.
- \_\_\_\_\_ When lifting spindle unit, keep in mind the front to back center of gravity is located approximately 12 inches from the front end and has a tendency to lean forward.
- \_\_\_\_\_ Each main system is protected internally by circuit breakers. Green indicates the breaker is “tripped” and red indicates the breaker is “Hot” (conducting electricity).
- \_\_\_\_\_ Clean any rust inhibitor from the machine surfaces. Move the column from side to side continually cleaning the machine base until all inhibitor is removed.
- \_\_\_\_\_ Install spindle unit on column, if required, using one of the approved methods described in the operation manual. (Spindle unit weighs 6,000 lbs, 2,800 Kgs.)

### Using fork lift angle iron brackets

- \_\_\_\_\_ Bolt brackets to each side of the spindle base.
- \_\_\_\_\_ Use large C-clamps to clamp the fork lift forks to the angle iron brackets. This will prevent any accidental slips. Loosen 1/2 13 x 3 1/2 Inch bolts on pendent arm to allow it to be moved out of the way.
- \_\_\_\_\_ Use a forklift to lift the spindle unit onto the column. Be careful to watch clearance of all items.
- \_\_\_\_\_ Install the Right (Fixed Side Rail) and removable dowel pins. Torque Side Rail bolts to 80 Ft/lbs.
- \_\_\_\_\_ Lift spindle unit into place. Push spindle base up against Right Side Rail.
- \_\_\_\_\_ Install left side rail (9202A) with 2 Belleville’s (9024E) opposing each other ( ) on each set screw (9202D), torque side rail bolts to 80 Ft/lbs.
- \_\_\_\_\_ Adjust the adjustable screws (9202D) on SIDE rails by tightening them until they bottom out, then unscrewing them 1/8 turn.
- \_\_\_\_\_ Measure the protrusion of the Sides Rails above the spindle base and record.  
 Right: Front \_\_\_\_\_ Rear \_\_\_\_\_  
 Left Front \_\_\_\_\_ Rear \_\_\_\_\_
- \_\_\_\_\_ Install the Right and Left Top Rails.
- \_\_\_\_\_ Install top rails (9202B) with 2 Belleville’s opposing each other ( ) on each adjustable set screw (9202D). Torque to 80 lbs.

- \_\_\_\_\_ Adjust the adjustable screws (9202D) on TOP rails by tightening them until they bottom out, then unscrewing them 3/4 turn.
- \_\_\_\_\_ Remove angle iron brackets from spindle base.
- \_\_\_\_\_ Connect air and oil lines per air logic diagram.
- \_\_\_\_\_ Remind customer of the proper air pressure and capacity connected to the machine. Air supply must be free from oil and water. Oil or water will damage electrical and air components.
- \_\_\_\_\_ Connect electrical wires in main rear enclosure if required using machine wiring diagram.

### MACHINE START-UP



When starting the machine for the first time, it may move out of control. Make sure all hands are clear of machine parts. Be ready to press the Emergency Stop button if needed.

- \_\_\_\_\_ **BEFORE** turning power on to the machine. Check all wires for security by using the correct screw driver and turning CW until movement stops. Stranded wire can “spread” slightly from vibration during transport.
- \_\_\_\_\_ Install electrical component covers inside the electrical enclosure with fasteners provided.
- \_\_\_\_\_ Turn main power on at the main disconnect switch located on the rear enclosure.
- \_\_\_\_\_ If machine moves out of control, turn power off and contact factory for help in trouble shooting.
- \_\_\_\_\_ If any of the circuit breakers “trip”, reset and call factory for possible trouble shooting.
- \_\_\_\_\_ Install and test the Internet connection to the machine. DO NOT download any updates unless instructed to do so by Rottler.
- \_\_\_\_\_ Check the computer control options and make sure that you turn on z-axis bit 2 and spindle bit 3.

### MACHINE MOVEMENTS

- \_\_\_\_\_ Make sure there is nothing obstructing the full vertical, horizontal or In/Out travel of the machine taking special notice of the rear enclosure, way travel and top of the spindle unit.
- \_\_\_\_\_ Put the machine in hand wheel mode and verify Vertical operation. Put an indicator on the cutter head and verify .001” movement per detent in course mode and .0001” in fine mode. If the indicator is jumpy the outer spindle adjustment may be too tight. Refer to manual and re-adjust.
- \_\_\_\_\_ Put the machine in hand wheel mode and verify Horizontal operation. Put an indicator on the cutter head and verify .001” movement per detent in course mode and .0001” in fine mode
- \_\_\_\_\_ Use the rapid buttons and verify proper vertical, horizontal and In/out travel.
- \_\_\_\_\_ Check limit switch operation with handwheel before using the power feed.
- \_\_\_\_\_ Move the machine to its vertical limits to verify proper operation.
- \_\_\_\_\_ Move the machine to its horizontal limits to verify proper operation.
- \_\_\_\_\_ Move the machine to its In/Out limits to verify proper operation.
- \_\_\_\_\_ Start the spindle and verify operation at all speeds.
- \_\_\_\_\_ Use the spindle creep buttons and verify proper operation.
- \_\_\_\_\_ Prime the oiling system. (See maintenance section of manual for complete details.)
- \_\_\_\_\_ Use a precision level and level the machine:

Record machine level readings below (must be within .0005). Back Way:

Back Way:

P1 \_\_\_\_\_ P2 \_\_\_\_\_ P3 \_\_\_\_\_ P4 \_\_\_\_\_ P5 \_\_\_\_\_ P6 \_\_\_\_\_ P7 \_\_\_\_\_ P8 \_\_\_\_\_

Back to Front Way:

P1 \_\_\_\_\_ P2 \_\_\_\_\_ P3 \_\_\_\_\_ P4 \_\_\_\_\_ P5 \_\_\_\_\_ P6 \_\_\_\_\_ P7 \_\_\_\_\_ P8 \_\_\_\_\_

Record Dial Indicator readings:

Spindle to Back Table:

P1 \_\_\_\_\_ P2 \_\_\_\_\_ P3 \_\_\_\_\_ P4 \_\_\_\_\_ P5 \_\_\_\_\_ P6 \_\_\_\_\_ P7 \_\_\_\_\_ P8 \_\_\_\_\_

Spindle to Front Table:

P1 \_\_\_\_\_ P2 \_\_\_\_\_ P3 \_\_\_\_\_ P4 \_\_\_\_\_ P5 \_\_\_\_\_ P6 \_\_\_\_\_ P7 \_\_\_\_\_ P8 \_\_\_\_\_

\_\_\_\_\_ Check mill tilt, and lift amounts with Y axis in the middle of travel, and record  
Amount of tilt \_\_\_\_\_

**The following procedures should be shown to personal involved in machine maintenance.**

See maintenance section of manual for complete details. Video of procedure can be viewed at:  
[www.rottlertube.com](http://www.rottlertube.com)

\_\_\_\_\_ Check, and adjust X axis gibs Should be .0002-.0005 (see maintenance for further instructions.)

\_\_\_\_\_ Adjust outer spindle bushings.

\_\_\_\_\_ Adjust inner spindle bearings

\_\_\_\_\_ Perform spindle sweep adjustment.

\_\_\_\_\_ Verify ALL axis backlash comp is operating properly, adjust if needed. Record actual readings after verification.

	Auto	Handwheel
X-Axis	_____	_____
Y-Axis	_____	_____
Z-Axis	_____	_____

\_\_\_\_\_ Install way cover brackets and way covers. Way Cover support brackets should be flush with way surface.

## INSTRUCTING THE OPERATOR

**Note: Rotter employees and representatives per company policy are not permitted to provide end user of Rottler equipment with any OEM specifications for the workpiece that is created by end user using Rottler equipment.**



\_\_\_\_\_ Explain to the customer and operator that at NO time is there to be any software or hardware other than Windows Auto Update and Rottler installed on this machine. This includes screen savers, anti-virus software, and any hardware device that installs software on the machine. Installation of screen savers and anti-virus software can cause dangerous control problems. Any installation of software or hardware will void the warranty on the machine.

\_\_\_\_\_ Explain to the customer and operator that the machine should be hooked up to the Internet anytime it is on. The software on the machine will automatically connect to our server to send back useful information on machine status.

\_\_\_\_\_ Connect customer supplied Internet to the machine. Verify that the Internet is accessible from the machine.

\_\_\_\_\_ Once the machine has been fully setup and is ready for operation create a Skype account for the machine following the instructions in the Installation Section of the manual.

\_\_\_\_\_ Explain to the customer and the operator how the to log onto Skype and communicate with Rottler when needed.

**⚠ WARNING**

\_\_\_\_\_ Computer Viruses will cause the machine control system to become unstable. This may cause the machine to make uncontrolled moves which could create a dangerous environment for the machine operator.

**IMPORTANT**

\_\_\_\_\_ Refer to Chapter 4, Control Definitions of the Machine Manual, Section: Computer and Controller System Safety. Explain and discuss this section carefully with Owner/Manager/Operator and have them sign off. Failure to do so will result in the machine warranty being Null and Void.

---

Signature / Title

\_\_\_\_\_ Explain to the customer the importance of backing up the block profiles to a separate device. Any computer failure or possible operator input error can result in the loss of all block profiles that were created for the machine. Refer to Chapter 5 of the machine manual for detailed instructions on backing up and restoring block profiles.

\_\_\_\_\_ Explain to the customer the proper way to turn the machine off when it is not in use. Do not leave the machine on overnight. It is important to close all programs followed by shutting down Windows before turning the main power switch off. Do not turn the main power switch off before shutting down Windows.

\_\_\_\_\_ Using the operating manual as a guide explain the function of all buttons.

\_\_\_\_\_ Cycle all machine movements and supervise the handling of same by operator.

\_\_\_\_\_ Demonstrate the differences of Manual and Auto operation.

\_\_\_\_\_ Fully explain the entire Auto Cycle from Centering to Auto Retract.

\_\_\_\_\_ Explain machine parameters and error messages. It is very important that the customer does not change parameter settings without first checking with Rottler Manufacturing. If certain parameters are changed the machine may make uncontrolled moves or not operate at all.

\_\_\_\_\_ Point out safety features to customer and operator. Do not push any buttons without thinking of safety first.

**⚠ CAUTION**

Do not assume the cutterhead micrometer has been calibrated.

\_\_\_\_\_ Install a work piece in the machine and perform an undersize test bore to qualify the micrometer setting to the customers measuring tools.

Note adjustments: + \_\_\_\_\_, - \_\_\_\_\_.

\_\_\_\_\_ Explain precision reset of tool in cutterhead.

\_\_\_\_\_ The following is a checklist to go through every time the machine is started to begin a cut or automatic cycle.

- Work piece secure
- RPM set
- Feed Rate set
- Correct program in use
- Program oriented correctly (vertical zero at correct place) Centering range adequate
- Guards in place
- Cutterhead secure
- Tool holder adjusted to the correct size
- Tool holder locked in place

\_\_\_\_\_ Proceed to have operator bore block to size.

- \_\_\_\_\_ Demonstrate and explain boring with the electronic hand wheel.
- \_\_\_\_\_ Explain the correct Feed rates and speeds from Cutting Insert Bulletin.
- \_\_\_\_\_ Cutter head change and expected stub bar performance.
- \_\_\_\_\_ Parts ordering, refer the to the operating manual for part numbers and description.
- \_\_\_\_\_ Offset tool bits, calibration of micrometer and anvil setting.
- \_\_\_\_\_ Train on ALL Rottler programs even if they need to be run in the air.
- \_\_\_\_\_ If Rottler CAM was provided to the customer train on any programs supplied by Rottler.
- \_\_\_\_\_ Review Emergency stop procedure with operator per operating manual.

### **MAINTENANCE SECTION**

- \_\_\_\_\_ Use the manual as a reference when explaining routine maintenance and lubrication.
- \_\_\_\_\_ Overload devices, There are no mechanical overload devices on this machine. The machine is protected from overload by the motor controllers. If the system is overloaded the controllers shut the motors off. The controllers can be reset by turning the main power off for at least 1 minute, then turning it back on.
- \_\_\_\_\_ Explain again the proper Inner and Outer spindle adjustment to the operator.
- \_\_\_\_\_ Air float adjustment.
- \_\_\_\_\_ Dampener cleaning.
- \_\_\_\_\_ Micrometer and anvil thread adjustment.
- \_\_\_\_\_ Inspection of tool bit hole in tool holders (deformation due to accidental impact).

Rottler Manufacturing and its employees or representatives are not responsible for any information regarding final specifications of any workpiece that is created as a final product when using Rottler equipment. It is the responsibility of the end user of Rottler equipment to determine the final dimensions and finishes of the workpiece that they are working on. Any information regarding final dimensions and finishes that appears in any Rottler literature or that is expressed by anyone representing Rottler is to be regarded as general information to help with the demonstration of or for operator training of Rottler equipment.

Note: Rotter employees and representatives per company policy are not permitted to provide end user of Rottler equipment with any OEM specifications for the workpiece that is created by end user using Rottler equipment.

General remarks on machine performance, adjustments as received and any further organization or parts required to complete the installation.

---



---



---



---



---



---



---



---



---



---



---



---



---



---



---



---



---



---



---



---



---



---

Instructions given to: \_\_\_\_\_

Sales/Service Engineer: \_\_\_\_\_ Date \_\_\_\_\_

Shop Foreman/Superintendent or Owner: \_\_\_\_\_ Date \_\_\_\_\_

**Once completed send this form to:**  
**Rottler Manufacturing**  
**attn: Service Manager**  
**8029 S 200 St**  
**Kent, WA 98032 USA**

**Alternately you may send this form via fax or e-mail:**  
**fax: [+1] 253-395-0230**  
**e-mail: service@rottlermfg.com**



This page intentionally left blank

## Removing Machine from Shipping Container

All F100 machines that are shipped in a container must be unloaded using the following method.

Machines will be loaded into containers at the factory mounted on metal tubes. These tubes will facilitate the sliding of the machine out of the container.

If the machine is to be removed from the container for transfer to its final destination the seal must not be broken.

Use lifting straps or chains placed through the tubes to pull the machine from the container. Make certain that the machine is clear of the container before attempting to lift machine.

The photo below shows the machine packed and sealed for placement into a container.



The photos below show the tubes that the machine sits on. Place straps or chains through these tubes to pull the machine out of the container. Take care not to damage the threads of the bolts holding the tubes to the machine.



**WARNING**

*Using an alternative method to remove the machine from the container that results in damage to the foil packaging seal or to the machine itself could result in the warranty being voided.*

## Methods of Lifting Machine Components

### Machine Bed

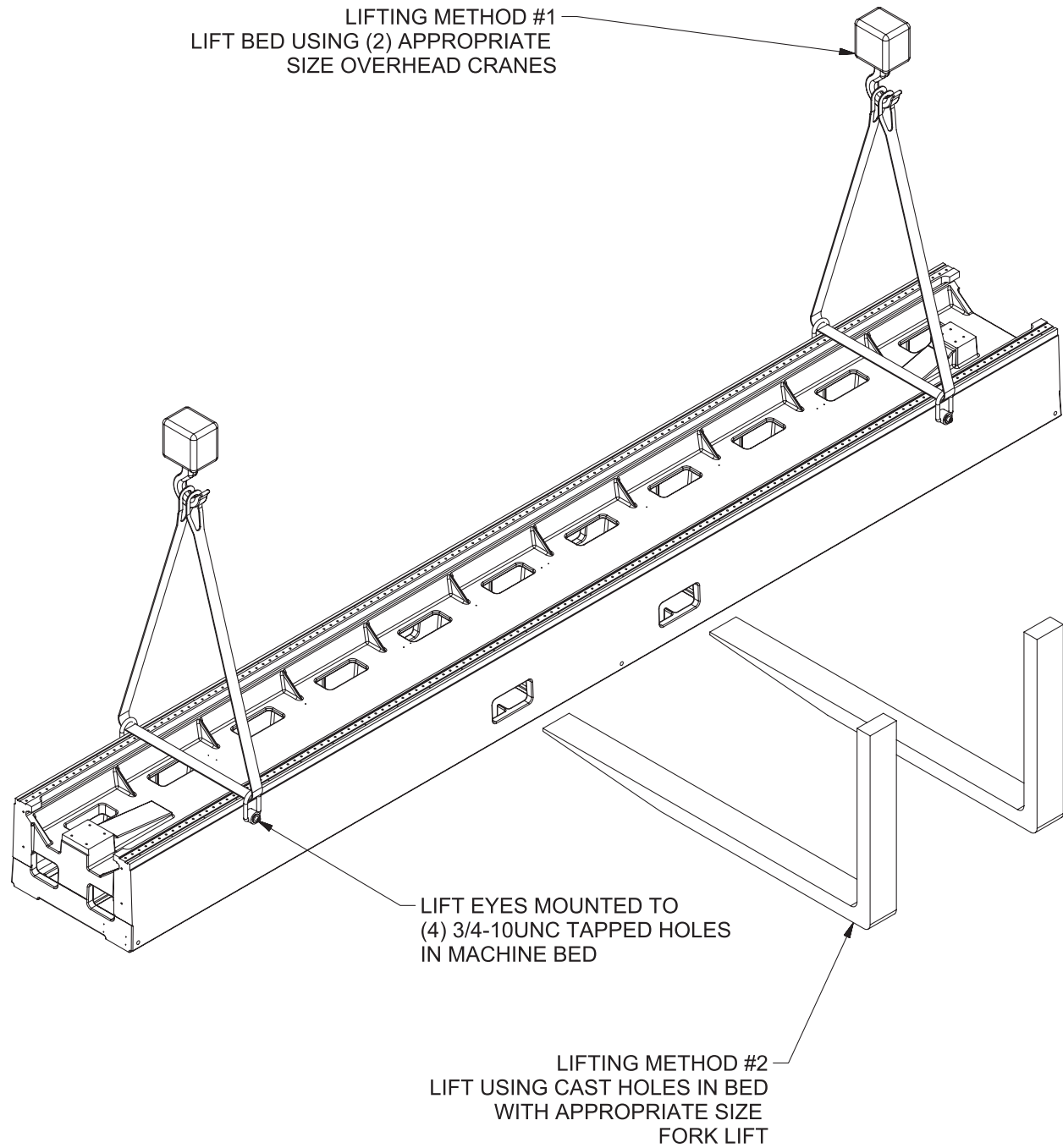

F107/F109 MACHINE BED  
LIFTING METHODS  
(APPROXIMATE WEIGHT: 17,000 (7,700 KG))



**Machine Table**

LIFTING METHOD #1  
LIFT TABLE USING (2) APPROPRIATE  
SIZE OVERHEAD CRANES

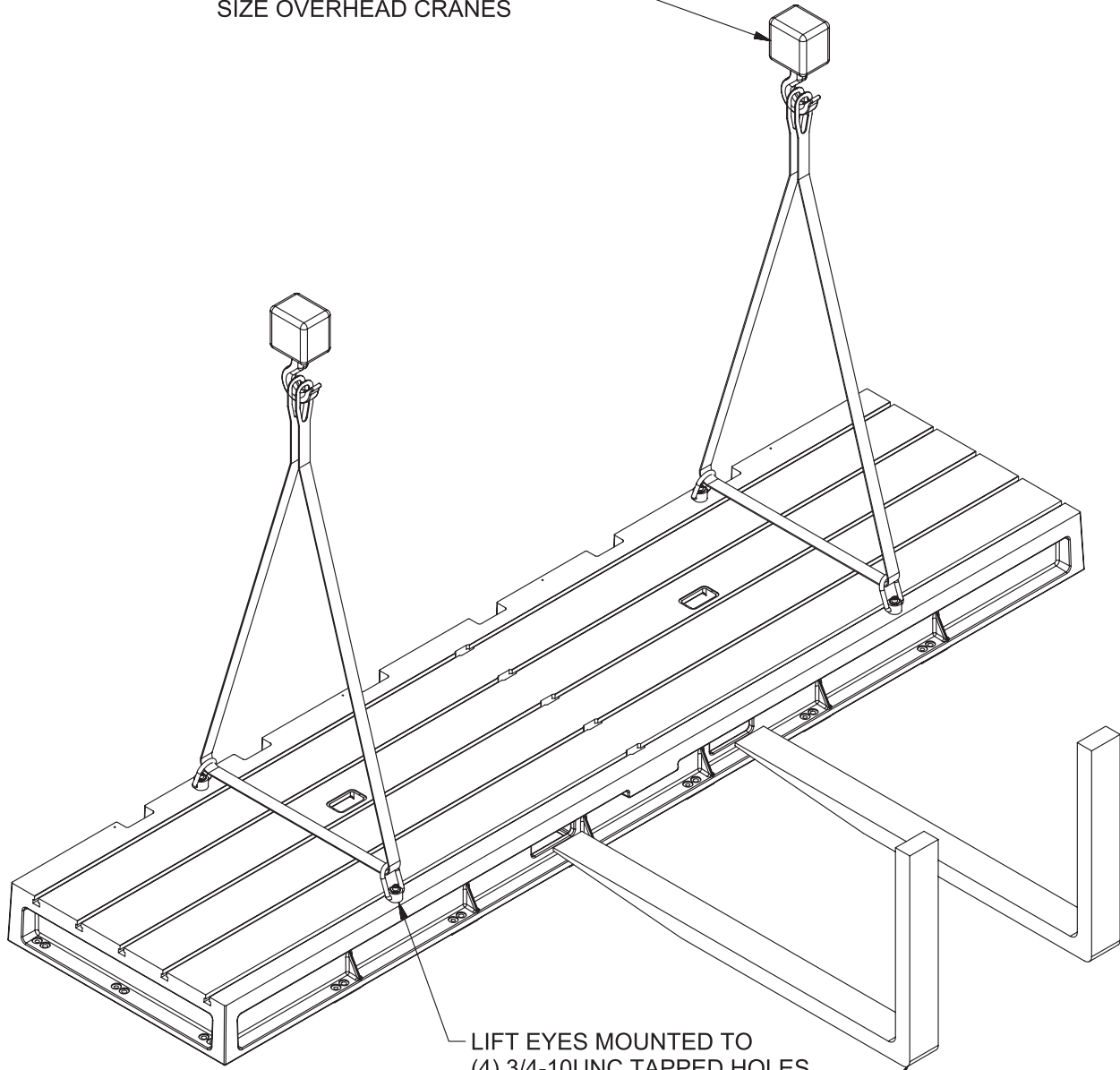

LIFT EYES MOUNTED TO  
(4) 3/4-10UNC TAPPED HOLES  
IN MACHINE TABLE

LIFTING METHOD #2  
LIFT USING CAST HOLES IN TABLE  
WITH APPROPRIATE SIZE  
FORK LIFT

F109 MACHINE TABLE  
LIFTING METHODS  
(APPROXIMATE WEIGHT: 15,000 (6,800 KG))

### Column and Spindle Assembly

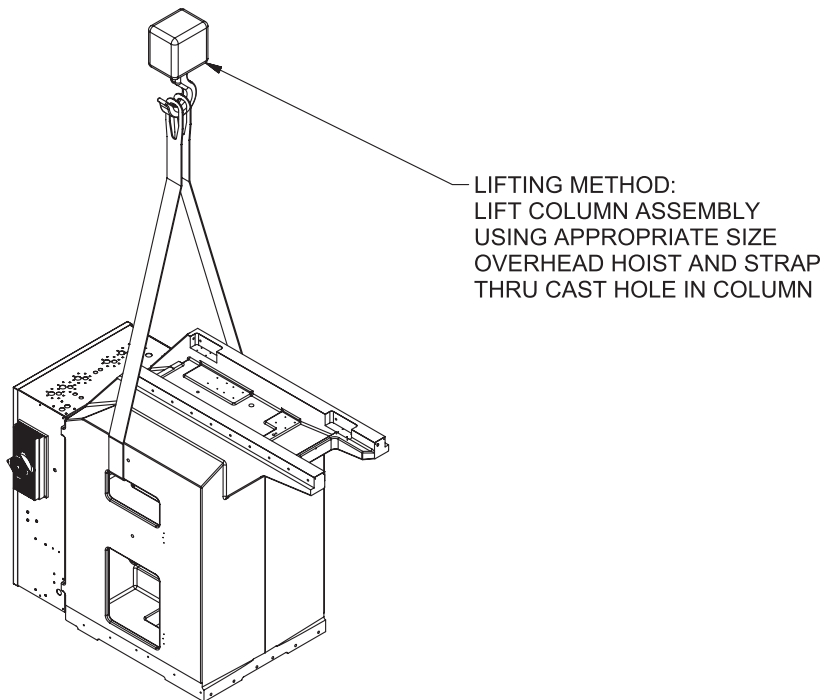
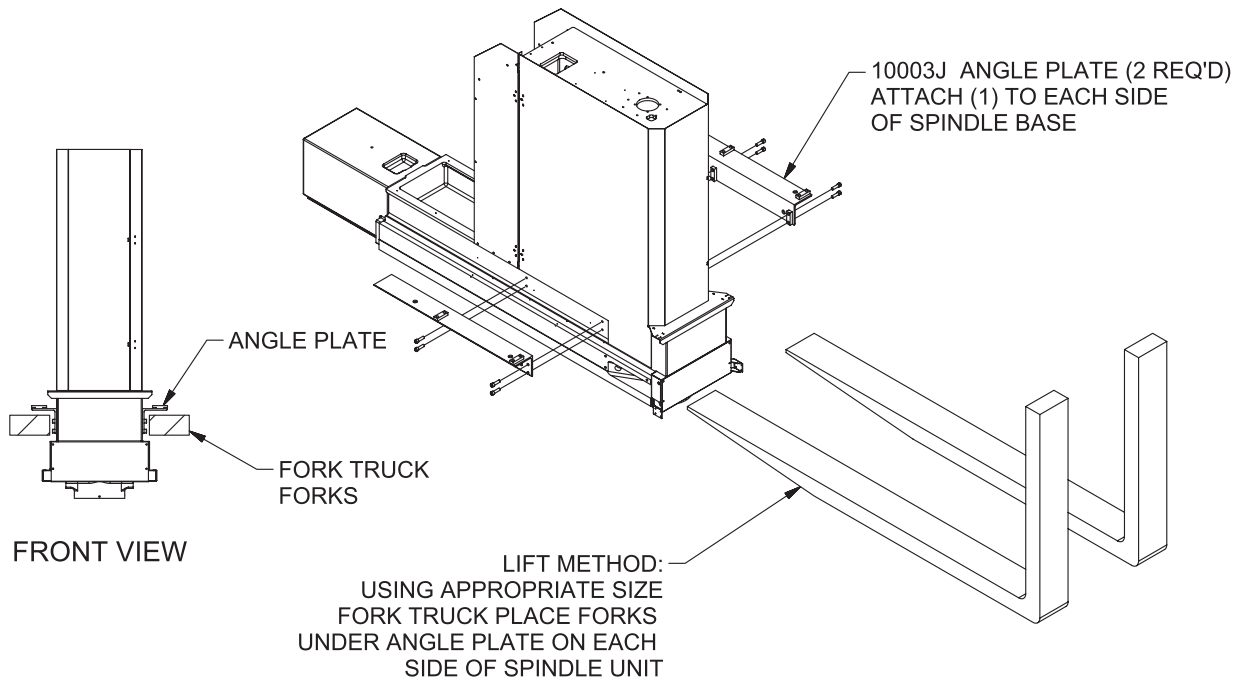

F109 COLUMN AND SPINDLE UNIT  
LIFTING METHODS  
(APPROXIMATE COLUMN WEIGHT: 7,000 (3,200 KG))  
(APPROXIMATE SPINDLE UNIT WEIGHT: 5,000 (2,300 KG))



## Installation Procedure

### Rottler F107/9 Series Foundation and Hold Install Procedure

Rottler machines require a good concrete foundation and hold down system. It is not recommended to install a machine on a cracked floor or over an expansion joint. The layout/position of the hold down holes can be found on the foundation drawings below.

There are two methods commonly used by customers:

1. Drill the concrete floor as per drawing layout before arrival of machine.
2. Place machine, mark floor through holes in machine base, move machine away then drill the floor.

The machine is provided with jacking bolts and steel pads to place between the jacking bolts and floor. For shipping, the steel pads are packed in a separate box and marked with yellow/black tape so the box is clearly visible. This allows the machine to be unpacked and removed from the shipping crate, placed on the floor on these steel pads without opening the accessory crates. When placing the machine on the jacking bolts, ALWAYS rough level to be sure that the weight of the machine is evenly distributed over all the jacking bolts.

Rottler recommend Hilti products as per attached list. 3/4" (20mm) diameter X 12" (300mm) long studs are recommended. Drill floor approx 7" (180mm) deep with 1" (25mm) drill. As it is difficult to drill concrete exactly on center, it is recommended to drill a pilot hole. After drilling and before injecting epoxy, it is also recommended to move the machine into place and make sure all studs fit through the holes in the base and travel all the way down into the holes so that approx 5" (130mm) protrude out of the floor. The machine may have to be moved a small amount to allow all studs to fit. Once this is checked, the studs can be removed then the epoxy injected into the bottom of the holes. Make sure all dust is vacuumed out of the holes before the epoxy is injected. Ensure that the epoxy is injected starting at the bottom of the holes to be sure the stud has maximum contact with the epoxy. The size of the holes will determine how much epoxy to inject into the holes before fitting the studs. On average, 1/2 to 2/3 of the hole should be filled with epoxy before the stud is installed. Be sure when the stud is installed, that the epoxy fills the hole to the top. Fit the washer and nut and tighten lightly to align the stud then allow the epoxy 24 hours to harden ready for leveling and final anchoring.

The link below will show how studs are installed:

<http://www.youtube.com/watch?v=2QtybOd7gyE>

The column is tied down with chains for transport, if it is required to move the column to help with installation of the hold down system. Be sure that the slideways are clean and lubed under the column before moving.

The following is a **MINIMUM** recommendation for safe reliable operation.

4000 PSI Concrete

Slab thickness of 36" (91cm)

The following is what should be completed before Rottler technician arrives. Below are procedures and photos that assist with the process.

Install all the anchor bolts for the slide way casting and table. We suggest putting the castings in place and marking the holes, for accurate placement. If a forklift will be used to install the workhead on the machine, do not install the 2 front, center, anchor studs for the table. The holes can be drilled, but do not install.

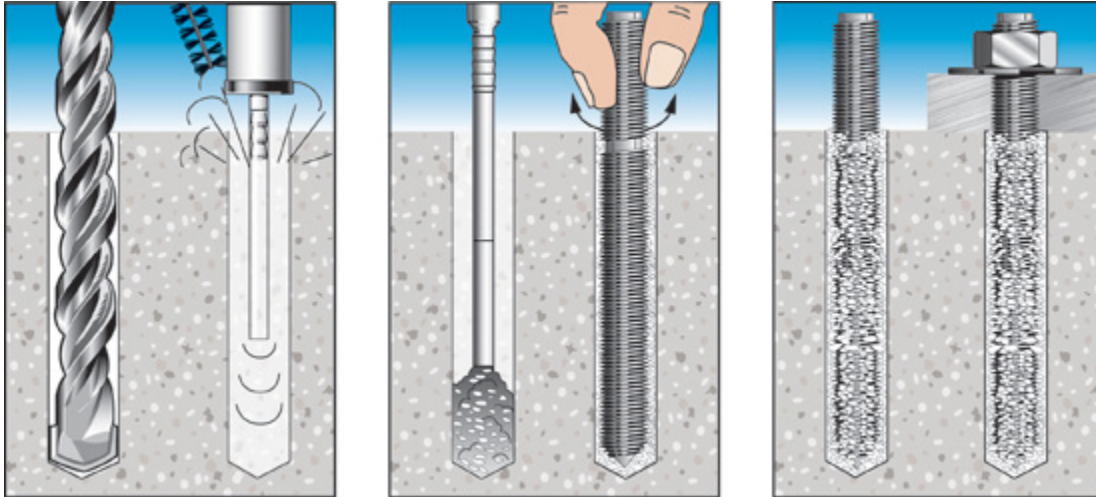

After the anchor studs are epoxied and set, put the slide way casting in place, over the anchor studs with a leveling pad under each jacking bolt. Do not put the table in place.



### F107 Hold Down and Jacking Bolt Locations

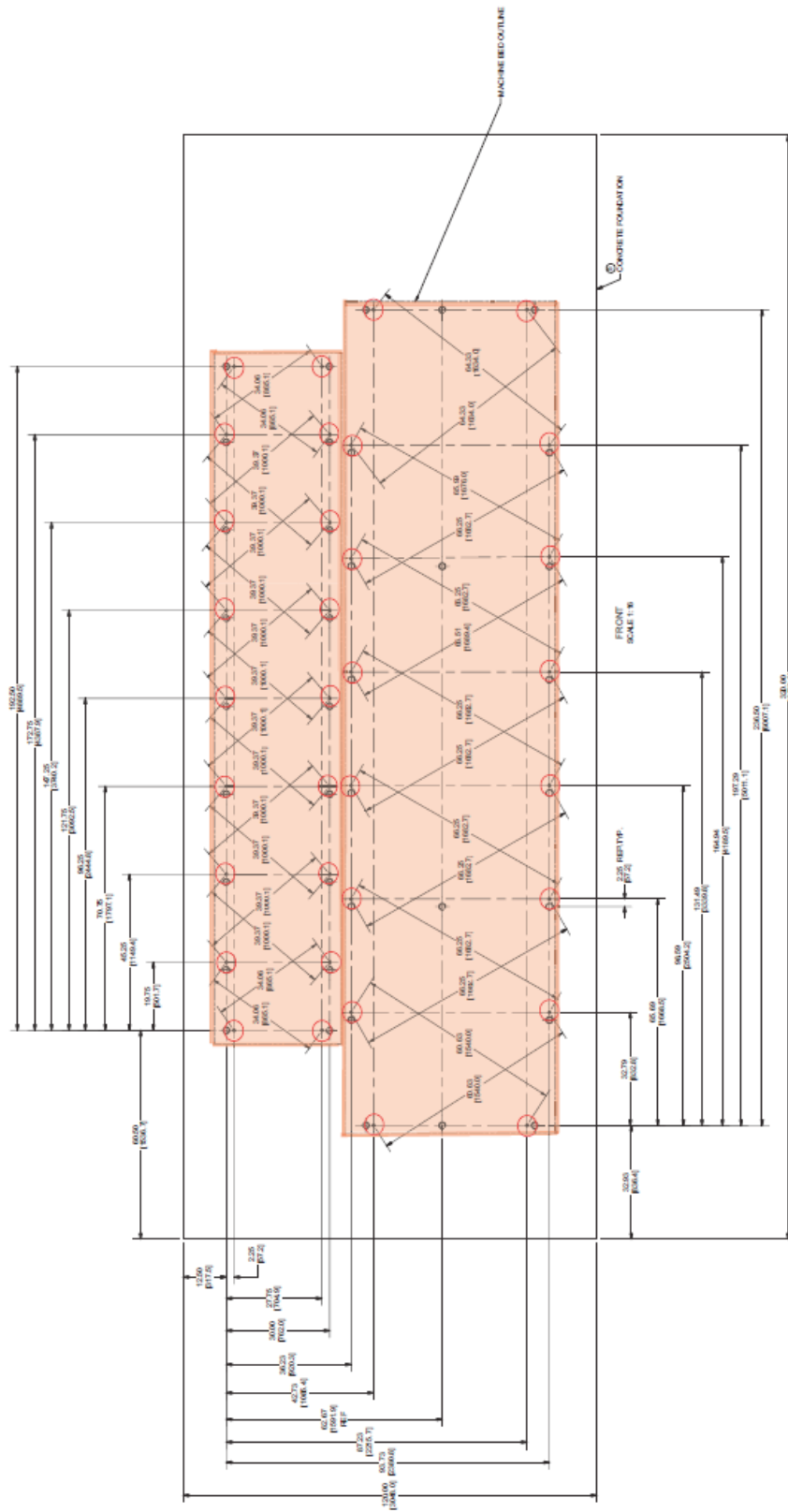

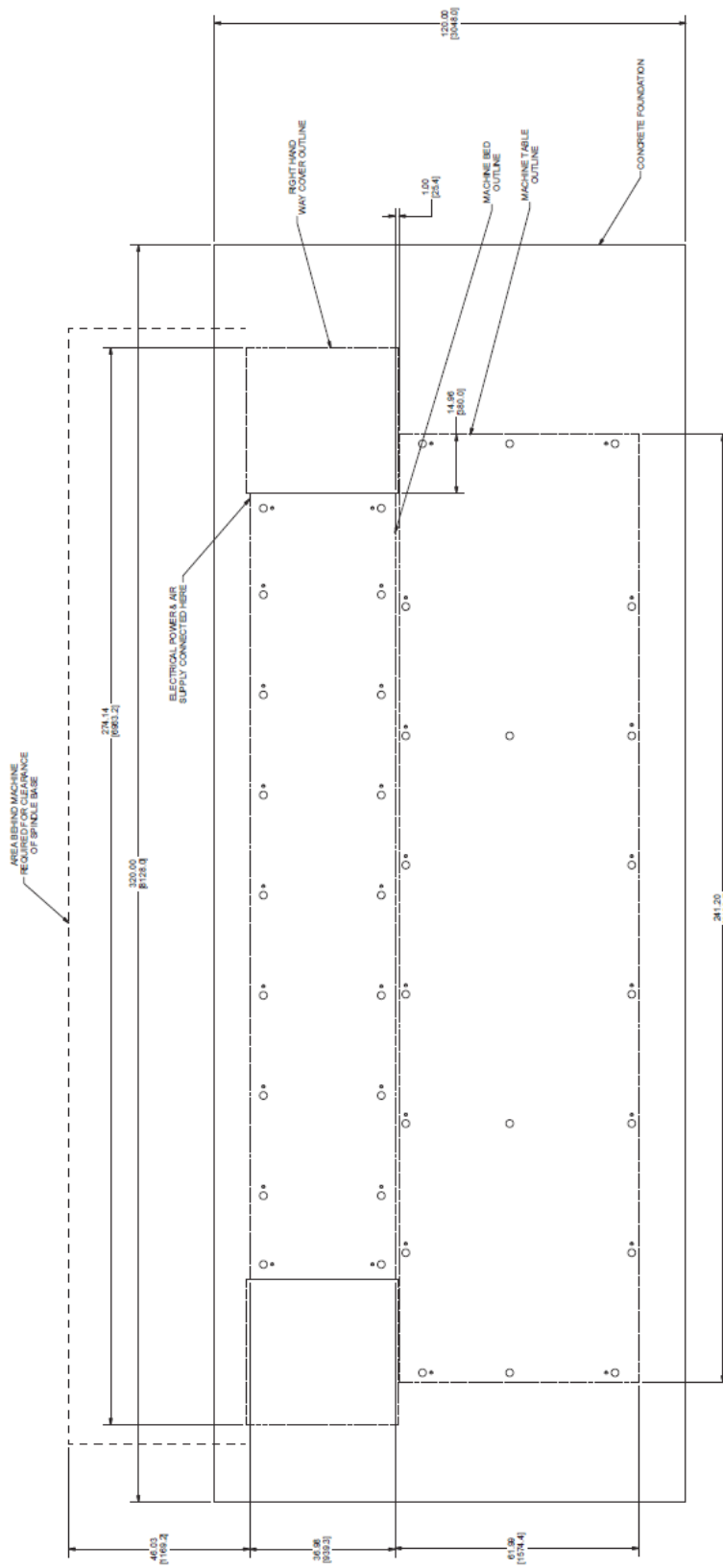

### F109 Hold Down and Jacking Bolt Locations

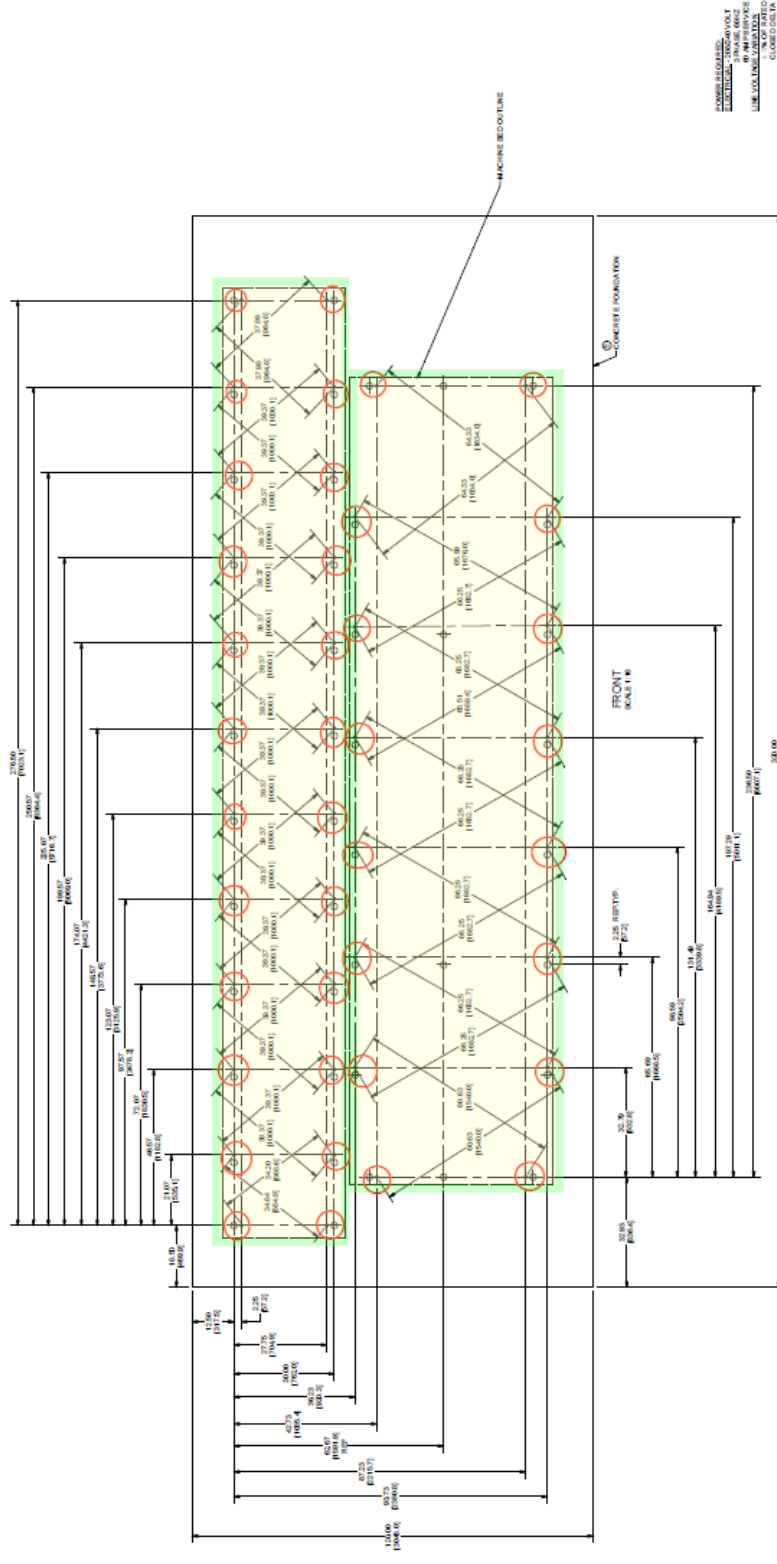

NUMBER RELEASED:  
DATE:  
BY:  
CHECKED:  
APPROVED:  
DATE:  
BY:  
DATE:  
BY:

### Machine Dimensions

#### Front View

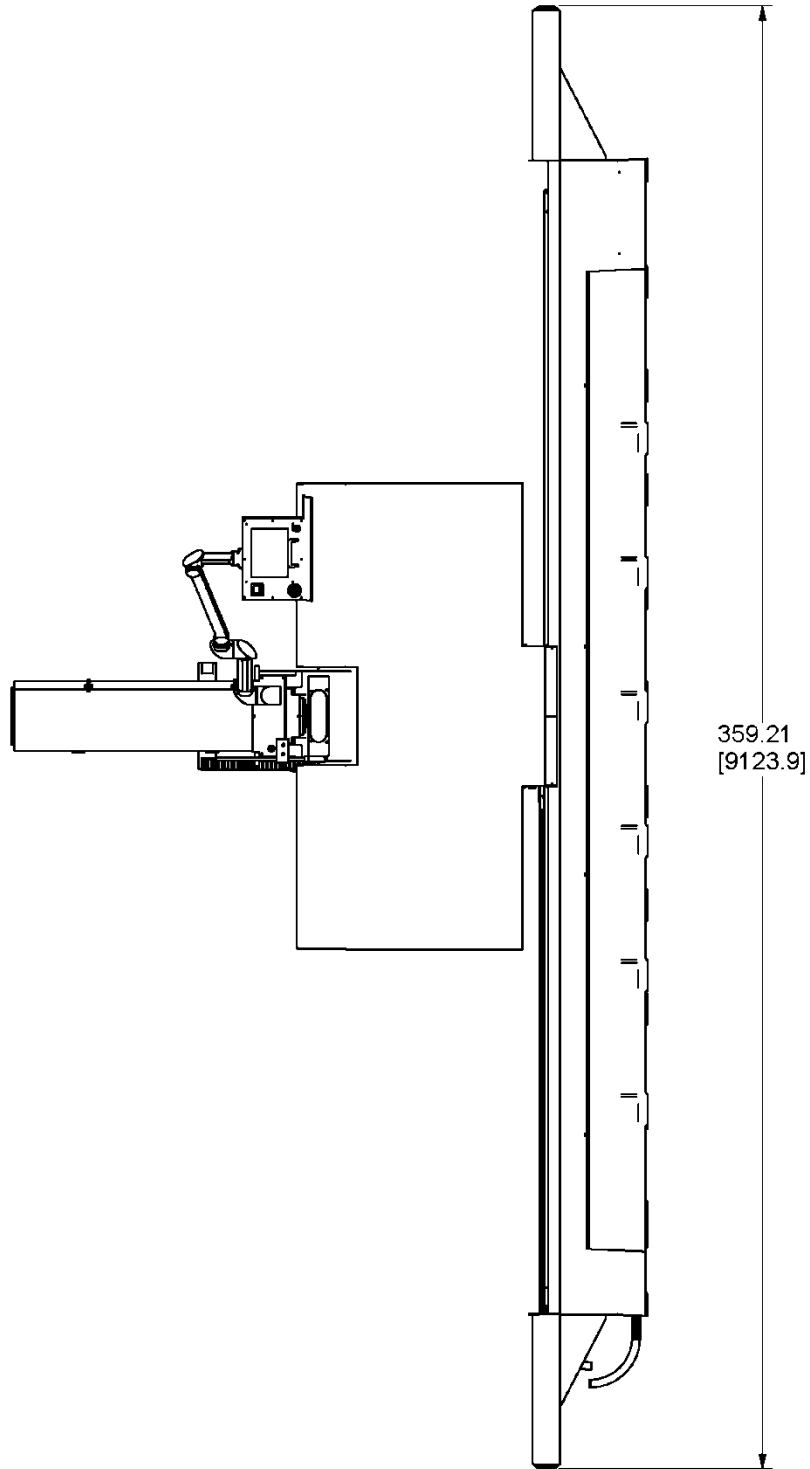

Front Machine View - 00569

**Left Side View**

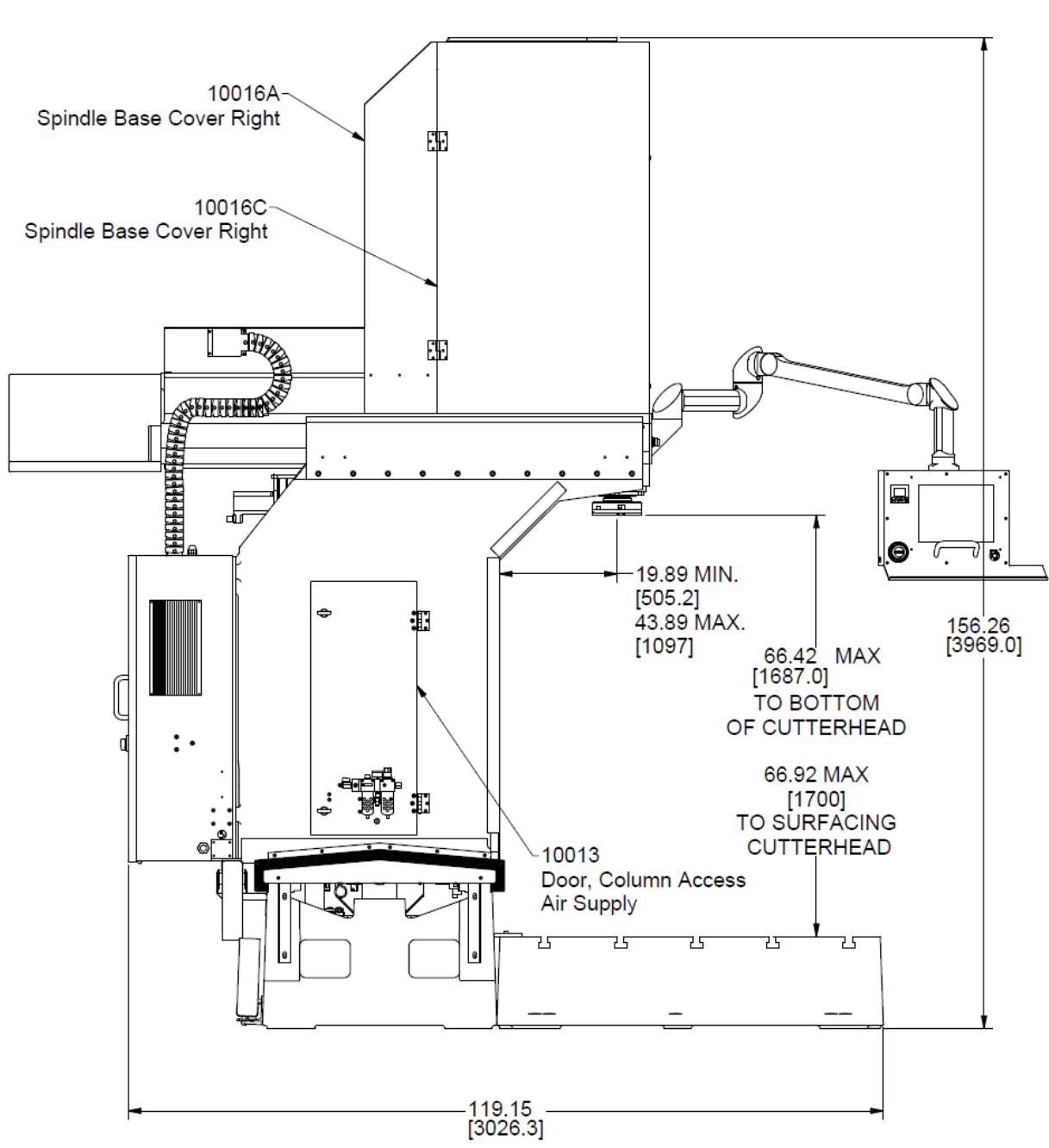

**IMPORTANT! Placement of Machine**

It is critical that the machine be placed in an area of the facility that has a stable thermal environment. The machine should be kept away from direct sunlight, large heating units, and doorways that would allow outside air direct contact on the machine.

Exposure to the above and other extremes in temperature will cause thermal drift to occur in the machines which could have a detrimental effect on machining accuracy. A number of unrepeatability errors in machine performance have been linked to this condition.

**Location**

The productivity of this machine will depend a great deal on its proper initial installation. Pay particular attention to the means by which work pieces are lifted into the machine as well as the material handling to and from other operations in your shop.

The proper loading arrangement and area location for your F103/4/5A machine is extremely important. A slow travel (6' to 10' per minute) power hoist, operated from either a bridge crane or a jib crane arrangement works very well. Verify the hoist has a rating that exceeds the load being lifted.

For the shop where large production runs are anticipated, the work pieces should be directly loaded and unloaded from a conveyor. If this is not the case we recommend considerable attention be given to the crane so that it covers an adequate area, to allow the operator to back up and remove work pieces without creating a dangerous, cluttered work area.

**Unpacking**

Use care in removing the crate materials from the machine. Be careful not to use force on any part of the machine.

Remove the toolbox, parallels and optional equipment from the machine. Completely clean these articles as well as the rest of the machine with solvent. Rust inhibitor was applied, at the time of shipment. Any of this left on the machine, will allow cast iron dust to collect in that area, which could cause premature wear.

**Column Hold Down**

The machine was shipped with the column held in place with chains and turnbuckles to the Main bed. Do not attempt to move the machine under power until these restraints have been removed.

**Leveling**

Located in the bottom of the main base are the leveling and tie down screws. If care is taken, the main base can be leveled extremely accurately. Start by placing the jacking pads under the jacking screws. Adjust the jacking screws so the lowest point of the main base is at least 1/4" off the jacking pad. Make sure all the jacking screws are touching their jacking pads. Use a precision machinist's level, and check the base at several points to get an idea where the high and low spots are, adjust evenly where necessary. Start with the back way surface. With your precision level, level the back way in the lengthwise direction to .0005" per foot. Take the readings approximately mid way between the jacking points.

Use a precision metal support to span the distance between the front and rear parallels. (Support must be parallel within .0005" in its length). Take readings over every jacking bolt and level within .0005" over the length of the base. Be sure to use the jacking points down the middle of the main base.

Recheck the way surfaces for level. Now check the machine table. Using the front jacking screws level the table within .0005" in both directions.

Be sure that all jacking bolts have approximately equal weight on them. As you go leveling the base snug the tie down bolts to help hold the main base in place. Recheck all areas of the main base for level.



### Air Supply

It is very important the air source for the F107/9AHL machine be moisture free. Water and oil in the line will result in early cylinder and valve failure. The factory recommends installing a water trap at the machine.

Attach a 100 PSI air source to the appropriate fitting located next to the small enclosure on the left rear of the machine near the bottom.



## Power Supply

This machine has the following power requirements:

- 208 to 240 VAC
- Three Phase
- 50 or 60 Hertz
- 60 amps

See illustration below for correct connection of “measured” incoming power. Connect three phase wiring to the electrical box located on the back of the machine in the lower right hand corner. See illustration below. If a “high leg” exists, this must be at Line 3. All ground wires go to ground block.

**Note: For voltages over 240 VAC (380 – 440 VAC) a transformer needs to be installed with the machine.**

## Grounding

This machine must be connected to a good earth ground rod. A 6 foot, 1/2” diameter, 15 OHM, Copper grounding rod driven into the earth next to the machines is preferred. **Not providing a grounding rod could void factory warranty.**

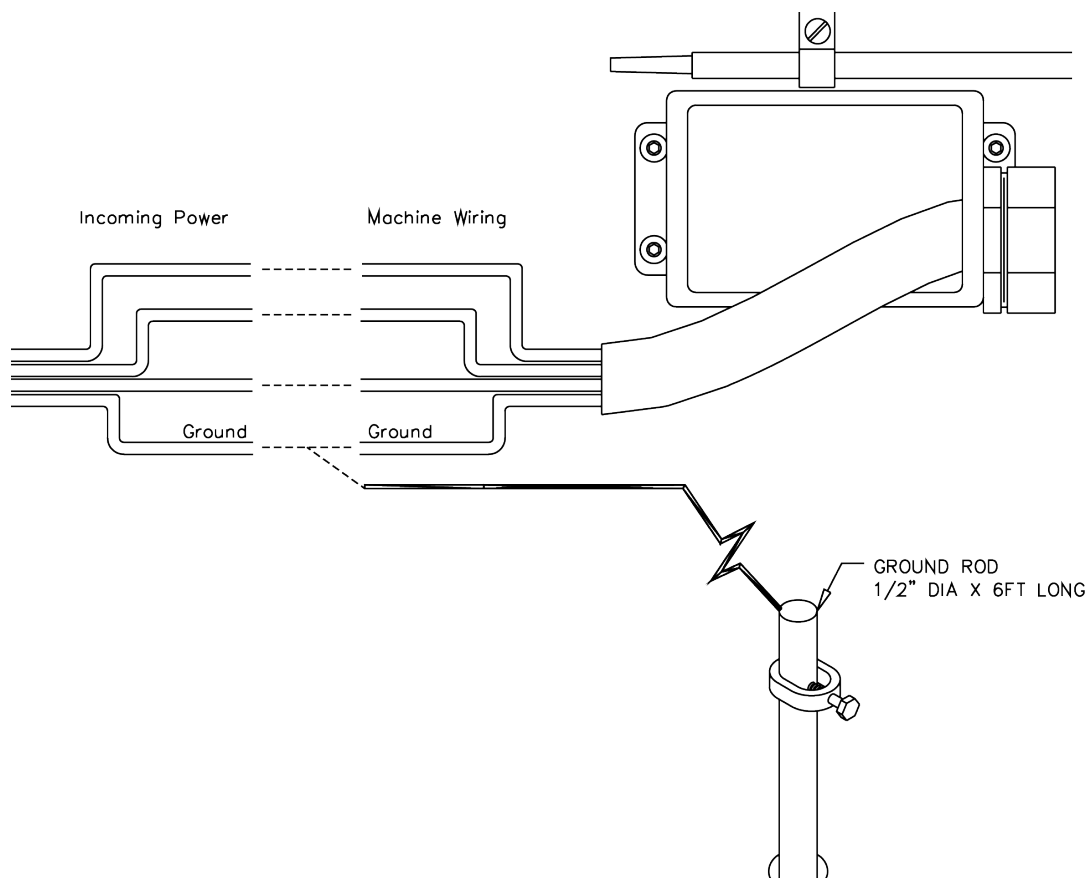

**IMPORTANT**

*Electrically connect in accordance with national and local electrical codes.*

## Creating a Skype Account

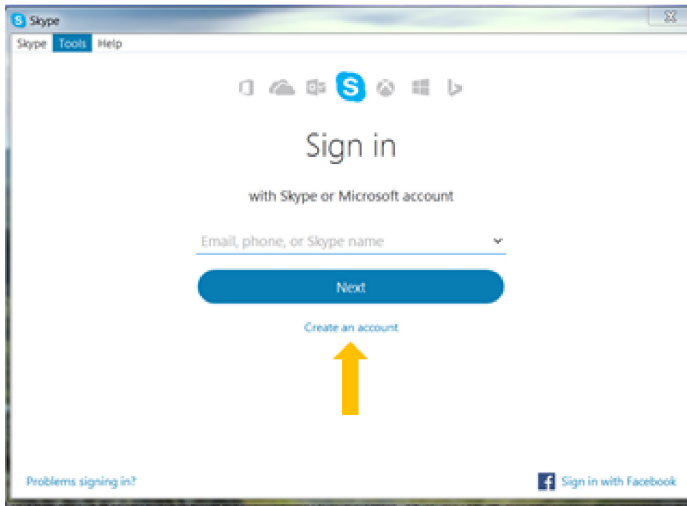

Click on create an account

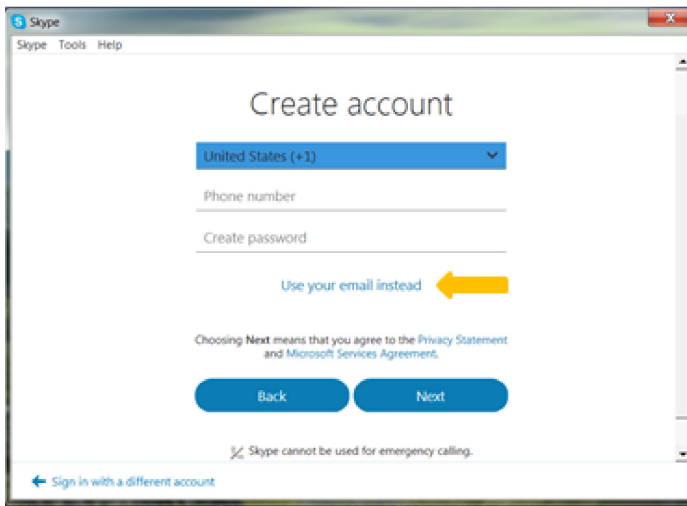

Click on: Use your email instead

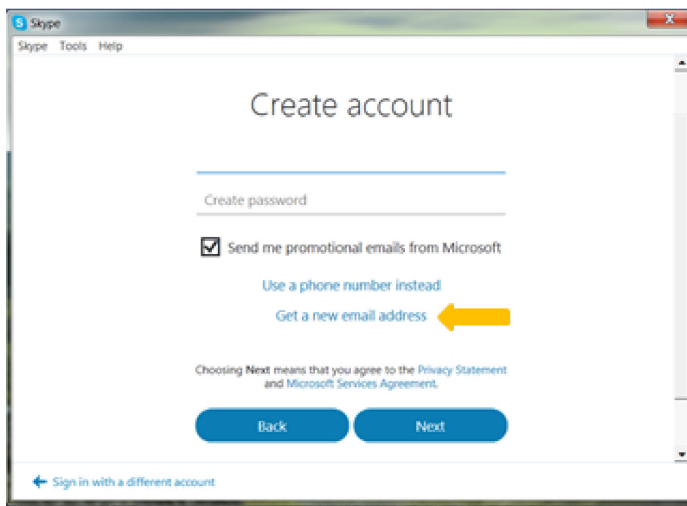

Click on: Get new email address

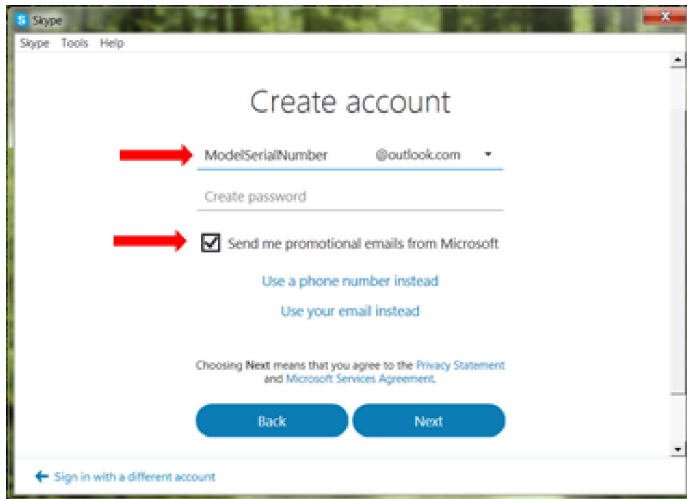

Name the email account using the Rottler machine Model and Serial number.

Ex: H85A111, EM69P001

Create a password that is easy to remember.

**Uncheck** the box to receive emails from Microsoft.

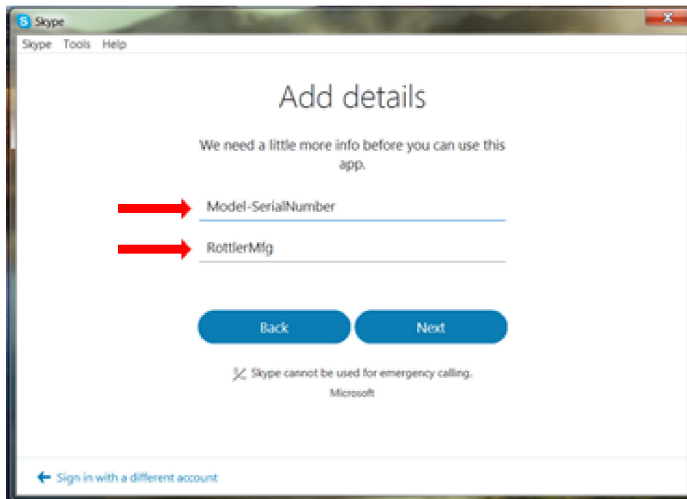

First Name: Model-Serial Number

Ex: H85A-111, EM69P-001

Last Name: RottlerMfg

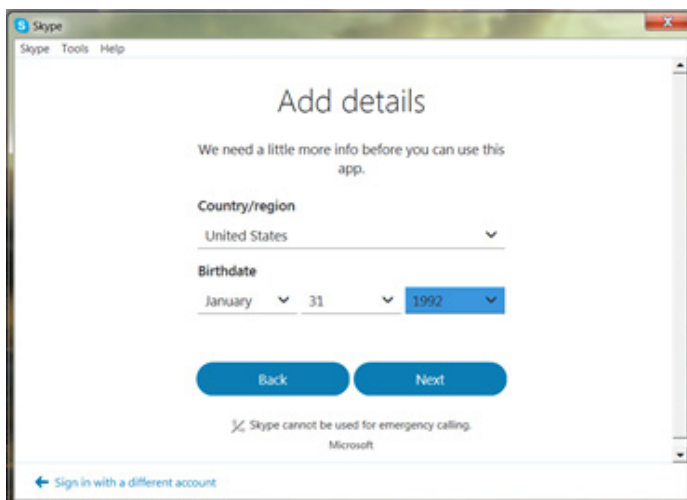

Select your Country/region

Birthday: Today's date, year 1992



Type the code exactly as it appears.

Click "Next"

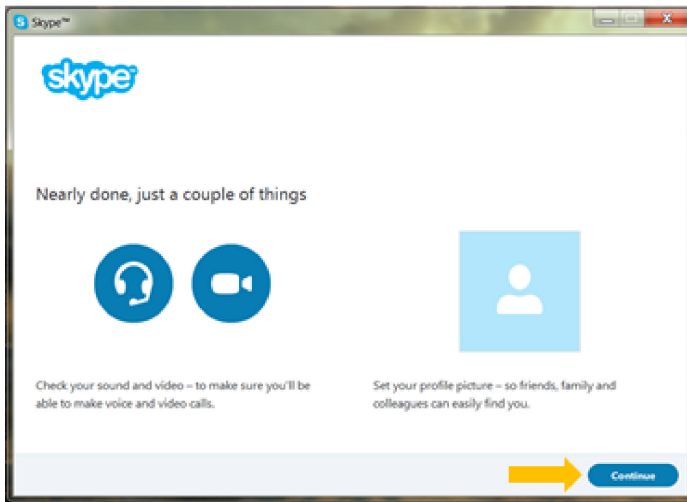

Click "Continue"

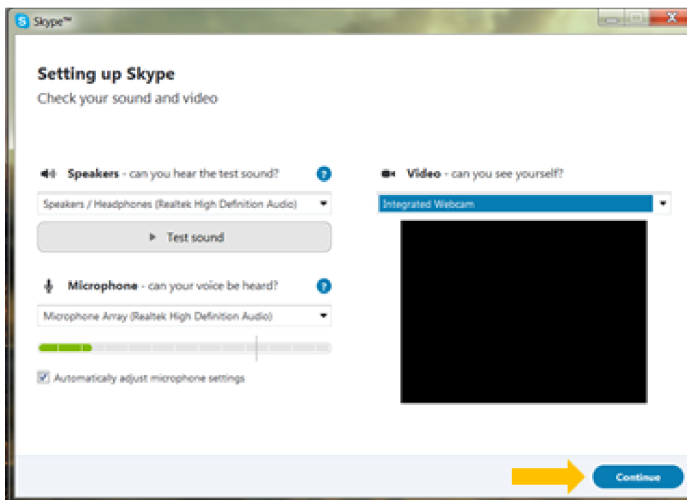

If your headset and/or web camera are hooked up you can verify that they are working here.

Otherwise, click "Continue"

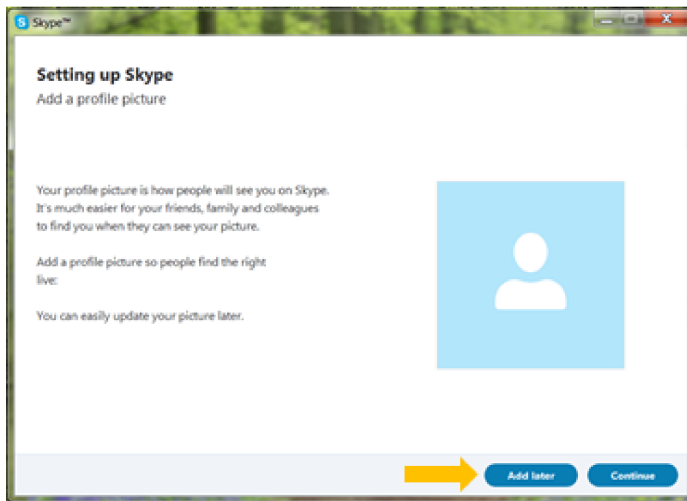

Click "Add later" to skip this part.

Your Skype account is set up and ready for use.

# SAFETY

## Contents

<b>Safety Information .....</b>	<b>3-1</b>
<b>Safety Instructions for Machine Use .....</b>	<b>3-1</b>
<b>Electrical Power .....</b>	<b>3-3</b>
<b>Machine Operator .....</b>	<b>3-5</b>
<b>Emergency Procedure .....</b>	<b>3-6</b>
<b>Computer and Controller System Safety .....</b>	<b>3-6</b>
<b>Electrical Safety Features Of Rottler DM Controlled Machines .....</b>	<b>3-7</b>

## Safety Information

For Your Own Safety Read This Instruction Manual Before Operating This Machine.

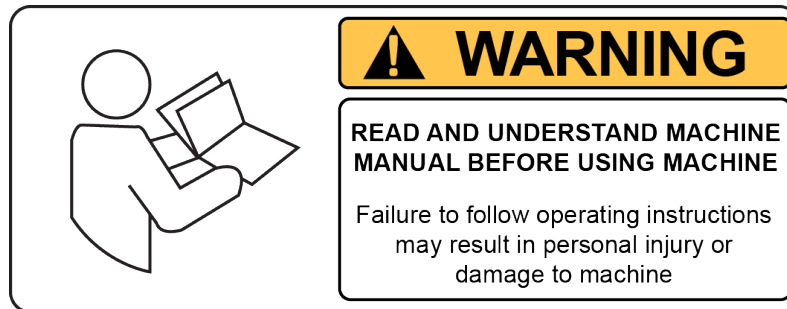

This is the safety alert symbol. It is used to alert you to potential personal injury hazards. Obey all safety messages that follow this symbol to avoid possible injury or death.



**DANGER** indicates an imminently hazardous situation which, if not avoided, will result in death or serious injury.



**WARNING** indicates a potentially hazardous situation which, if not avoided, could result in or serious injury.



**CAUTION** indicates a potentially hazardous situation which, if not avoided, may result in minor or moderate injury.



**CAUTION** used without the safety alert symbol indicates a potentially hazardous situation which, if not avoided, may result in property damage.

### Safety Instructions for Machine Use



This machine is capable of causing severe bodily injury

**ONLY A QUALIFIED, EXPERIENCED OPERATOR SHOULD OPERATE THIS MACHINE. NEVER ALLOW UNSUPERVISED OR UNTRAINED PERSONNEL TO OPERATE THE MACHINE.** Make sure any instructions you give in regards to machine operation are approved, correct, safe, and clearly understood. Untrained personal present a hazard to themselves and the machine. Improper operation will void the warranty.

**KEEP GUARDS IN PLACE** and in proper working order. If equipped with doors, they must be in the closed position when the machine is in operation.



**KEEP WORK AREA CLEAN.** Cluttered areas and benches invite accidents.



**KEEP CHILDREN AND VISITORS AWAY.** All children and visitors should be kept a safe distance from work area.

**WEAR THE PROPER APPAREL.** **DO NOT** wear loose clothing, gloves, rings, bracelets, or other jewelry which may get caught in moving parts. Non-Slip foot wear is recommended. Wear protective hair covering to contain long hair.

**ALWAYS USE SAFETY GLASSES.** Also use face or dust mask if cutting operation is dusty. Everyday eye glasses only have impact resistant lenses, they are NOT safety glasses.



**DO NOT OVER-REACH.** Keep proper footing and balance at all times.

**USE THE RECOMMENDED ACCESSORIES.** Consult the manual for recommended accessories. The use of improper accessories may cause risk of injury.

**CHECK DAMAGED PARTS.** Before further use of the machine, a guard or other part that is damaged should be checked to determine that it will operate properly and perform its intended function. Check for alignment of moving parts, breakage of parts, mounting, and other conditions that may affect its operation. A guard or other part that is damaged should be properly repaired or replaced.

**NEVER OPERATE A MACHINE WHEN TIRED, OR UNDER THE INFLUENCE OF DRUGS OR ALCOHOL.** Full mental alertness is required at all times when running a machine.

**IF AT ANY TIME YOU ARE EXPERIENCING DIFFICULTIES** performing the intended operation, stop using the machine! Then contact our service department or ask a qualified expert how the operation should be performed.

**DO NOT MODIFY OR ALTER THIS EQUIPMENT** in any way. If modifications are deemed necessary, all such requests must be approved and/or handled by Rottler Manufacturing. Unauthorized modifications could cause injury and/or damage to machine and will void the warranty.

**SAFETY DECALS SHOULD NEVER BE REMOVED.** They are there to convey important safety information and warn of potential hazards.

**ALL LOCAL SAFETY CODES AND REGULATIONS** should be followed when installing this machine.

**ONLY QUALIFIED PERSONAL** should perform service on the electrical and control systems.

When boring the machine is capable of throwing metal chips over 10- feet from the cutting area. Always use the guards. Eye protection must be worn at all times by the operator and all other personnel in the area of the machine.



**CAUTION** No list of safety guidelines can be complete. Every piece of shop environment is different. Always consider safety first, as it applies to your individual working conditions. Use this and other machinery with caution and respect. Failure to follow guidelines could result in serious personal injury, damage to equipment or poor work results.

**Electrical Power**

**THIS MACHINE IS AUTOMATICALLY CONTROLLED AND MAY START AT ANYTIME**

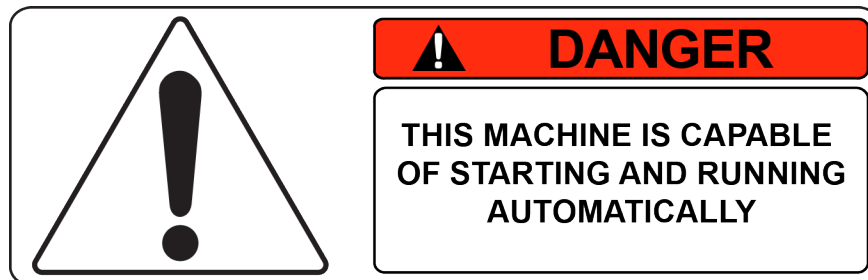

All electrical power should be removed from the machine before opening the rear electrical enclosure.

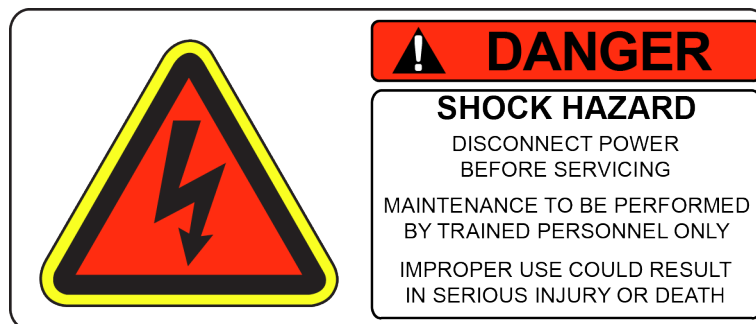

In the event of an electrical short, grounding reduces the risk of electric shock by providing a path of least resistance to disperse electric current.

Electrocution or a fire can result if the machine is not grounded correctly. Make sure the ground is connected in accordance with this manual. **DO NOT** operate the machine if it is not grounded.

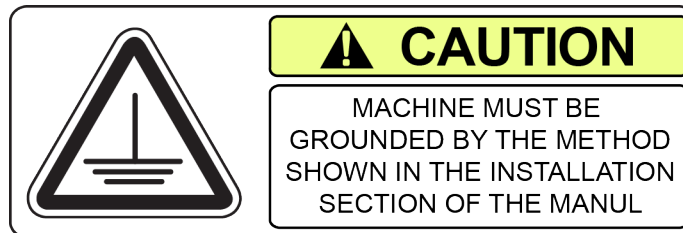

**CAUTION** No single list of electrical guidelines can be comprehensive for all shop environments. Operating this machinery may require additional electrical upgrades specific to your shop environment. It is your responsibility to make sure your electrical system comply with all local codes and ordinances.

**WARNING** This machine operates under computerized control and, as is all computerized equipment, and is susceptible to extraneous electrical impulses internally for externally produced. The machine may make moves out of the operator control at any time. The operator should work in and around the machine with caution at all times.

The operator and nearby personnel should be familiar with the location and operation of the Emergency Stop Button.

Make sure all electrical equipment has the proper overload protection. ***This machine should have a fully isolated power supply*** to prevent damage and uncontrolled movement of the machine. If this machine is on the same power lines that are running to other electrical equipment (grinders, welders, and other AC motors) electrical noise can be induced into this machines electrical system. Electrical noise can cause the controller to see false signals to move. Not supplying a fully isolated supply to the machine may void factory warranty. Refer to the Power supply section located in the Installation section for voltage and

## Machine Operator

The operator of this machine should be a skilled machinist craftsman who is well versed in the caution, care, and knowledge required to safely operate metal cutting tools.

If the operator is not a skilled machinist he/she must pay strict attention to the Operating Instructions outlined in this manual, and get instruction from a qualified machinist in both production and operation of this machine.

This machine has the following areas of exposed moving parts that you must train yourself to respect and stay away from when they are in motion:

**Cutting Tool Area** – Any operation involving hands in the cutter head area, such as inspection or alignment of the cutter head or tools, changing Centering Fingers, tool insertion, and removal, cutter head changes, and size checking etc. requires the machine to be in Neutral.

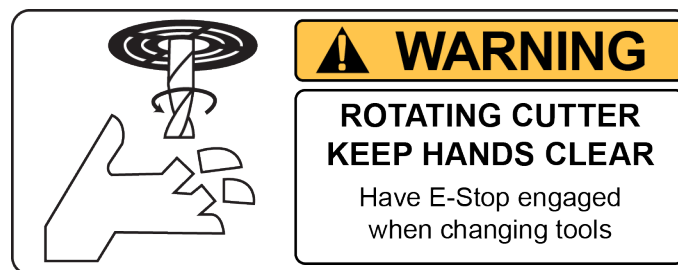

**Machining** – Eye protection must be worn during all operations of the machine. Hands must be kept completely away from the cutter head. All chip guards must be in position during machine operations.



**CAUTION** **Work Loading and Unloading** – Carefully develop handling methods of loading and unloading work pieces so that no injury can result if hoist equipment or lift connection should fail. Periodically check lift components for damage that may cause failure.

**CAUTION** **Machine Maintenance** – Any machine adjustment, maintenance or parts replacement absolutely requires a complete power disconnection from the machine.

## Emergency Procedure

Assuming one of the following has occurred: tool bit set completely off size, work piece or spindle base not clamped, spindle is not properly centered, and these mistakes will become obvious the minute the cut starts

**PRESS THE EMERGENCY STOP BUTTON** (on the front control panel) **IMMEDIATELY!**

Find out what the problem is; return the spindle to its up position without causing more damage. To restart the machine, turn the Emergency Stop Button CW until the button pops out

Be alert to quickly stop the machine in the event of a serious disruption of the boring process either at the top or bottom of the bores.

**“REMEMBER”** metal cutting tools have the speed and torque to severely injure any part of the human body exposed to them.

## Computer and Controller System Safety

The computer and controller are located in the main rear electrical enclosure. This unit is a full computer, running Windows 7 64 Bit operating system. Contact the factory if more information on the computer system is required.

**IMPORTANT** The computer in this machine has the ability to connect to the World Wide Web via Ethernet or Wireless using a USB wireless (Wi-Fi) adapter. Updating the Rottler software should **ONLY** be done when directed to do so by a Rottler service technician. Updating Rottler Software when not directed by Rottler personnel will result in a non-operational machine.

The machine should be hooked up to the Internet anytime it is on. The software on the machine will automatically connect to our server to send back useful information on machine status.

Any “IT” personnel should **ALWAYS** get approval from Rottler before doing ANYTHING on the computer.

**! DANGER** This machine is capable of causing severe injury or death. Doing any of the following without Rottler’s direct consent may cause severe injury or death.

**! WARNING** Do not attempt to install USB devices in the PCI ports. These ports have high voltage and any attempt to connect a USB device in these ports will result in destruction of that device. There is also the possibility of damage to the computer system of the machine.

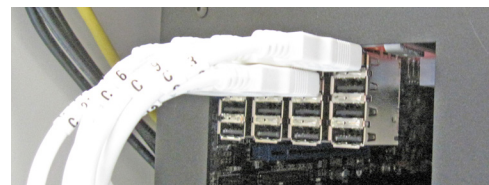

**IMPORTANT** Downloading any program or changing any Rottler or Computer settings may cause the machine and/or software to become unstable. **DO NOT** install ANY screen saver, Anti-Virus, Spyware or any type of Security software on the computer. This could create a hazardous environment for the operator and personnel around the machine. Performing any of the above will also result in the machine warranty being NULL and VOID.

**IMPORTANT** **DO NOT** connect any type of external hardware to the computer via USB or any other means. Do not install any type of Device Driver. This could create a hazardous environment for the operator and personnel around the machine. Performing any of the above will also result in the machine warranty being NULL and VOID.

## **Electrical Safety Features Of Rottler DM Controlled Machines**

All Rottler machines that use the DM operational control system are designed to comply with all applicable safety standards. This includes but is not limited to the following systems:

Thermal sensors in all motors and motor controls.

1. Current sensors in all motor control panels.
2. Electrical breakers to prevent voltage surges and spikes from reaching electrical system.
3. Electrical lockout on main electrical enclosure.
4. E-Stop that shuts down all operational systems in an event of an emergency.

All thermal and current limits for motors and motor controls are preset at the factory. In the event that any of those parameters are exceeded during operation of the machine, the machine control system will shut down the machine and a warning of the specific fault will appear on the control screen.

# CONTROL DEFINITIONS

## Contents

<b>Control Definitions .....</b>	<b>4-1</b>
<b>Computer and Controller System Safety for DM Controlled Machines.....</b>	<b>4-1</b>
Master Power On/Off Switch.....	4-2
<b>Initialization Screen.....</b>	<b>4-3</b>
<b>General Information .....</b>	<b>4-3</b>
<b>Home.....</b>	<b>4-3</b>
<b>Program Select .....</b>	<b>4-3</b>
New.....	4-4
Options .....	4-4
Delete .....	4-4
<b>Mode Select.....</b>	<b>4-5</b>
New.....	4-5
Std (Standard) Setup .....	4-6
Options .....	4-6
Delete .....	4-7
<b>Basic Machine Controls.....</b>	<b>4-7</b>
<b>Cylinder Bore, General Bore 3 Axis (without Tool Changer).....</b>	<b>4-8</b>
Set Zero Tab.....	4-8
Actual Position .....	4-8
Velocity Override.....	4-8
Zero Buttons.....	4-8
Handwheel Buttons .....	4-9
Spindle Start.....	4-9
CW and CCW Creep.....	4-9
Jog Buttons .....	4-9
Move to .....	4-9
Move To Zeros .....	4-9
CW and CCW Index.....	4-9
Using SSV (Spindle Speed Variance).....	4-10
Setting Spindle Index .....	4-10

<b>Probe Auto Center</b> .....	4-10
<b>Vertical Stops Tab</b> .....	4-11
Horizontal Offset for Honing.....	4-12
<b>Left and Right Locations Tab</b> .....	4-13
Cylinder Bore – Bore Locations .....	4-13
Blueprint .....	4-13
Move Buttons .....	4-13
Bore Buttons .....	4-14
Indicated .....	4-14
Set Buttons .....	4-14
Copy Values.....	4-14
Difference .....	4-14
Bore Left and Right.....	4-14
Probing .....	4-15
Probe Buttons .....	4-15
Probe Left or Right .....	4-15
Probed Diameter .....	4-15
<b>LOWER SLEEVE REPAIR</b> .....	4-15
Block Clearance .....	4-15
Centering Height .....	4-16
X-Clearance .....	4-16
180 index (check box) .....	4-16
X-Overshoot .....	4-16
Start Boring Height .....	4-16
Bottom of the Bore .....	4-17
Stop and Index Spindle after Cycle.....	4-17
<b>Probing For The Mill Cycle</b> .....	4-18
<b>Lifter Bore</b> .....	4-20
<b>Cylinder Bore 4 Axis</b> .....	4-20
Set Zero Tab.....	4-20
Jog Controls .....	4-20
4th Axis Degree and Move .....	4-20
4th axis Brake.....	4-21
Light Clamp .....	4-21
Full Clamp.....	4-21
Retract.....	4-21
<b>Table Of Tools</b> .....	4-22



**Table Of Tools General Information .....4-22**  
**Accessing Table Of Tools.....4-22**  
**Add Tool.....4-23**  
**Remove Tool.....4-24**  
**Set Active Tool .....4-24**  
**Setting Tool Offsets..... 4-25**  
**Z Location from Zero .....4-26**  
**Z Touch Off Height.....4-26**  
**Add Tool Radius?.....4-26**  
**Applying Table of Tools to Rottler Programs .....4-27**  
**Fixture Select .....4-27**

## Control Definitions

The purpose of this chapter is to define the function of the buttons throughout the various screens. Certain button functions may not make sense right away in this chapter. As the operator reads through the Operating Instructions chapter of this manual, the function of these buttons will become clear.

### Computer and Controller System Safety for DM Controlled Machines

The computer and controller are located in the main rear electrical enclosure. This unit is a full computer, running Windows 7 64 Bit operating system. Contact the factory if more information on the computer system is required.

**IMPORTANT:** The computer in this machine has the ability to connect to the World Wide Web via Ethernet or Wireless using a USB wireless (Wi-Fi) adapter. Updating the Rottler software should ONLY be done when directed to do so by a Rottler service technician. Updating Rottler Software when not directed by Rottler personnel could result in a non-operational machine.

It is recommended that the machine be hooked up to the Internet anytime it is on. The software on the machine will automatically connect to our server to send back useful information on machine status. It will also record performance parameters that will be used to evaluate any occurrence of a malfunction.

The Auto Update for the Windows Firewall (Security) and Windows Defender (Anti-Virus) is turned on. The computer will automatically download the updates and then install them when the computer is shut down every Friday night.

Any "IT" personnel should ALWAYS get approval from Rottler before doing ANYTHING on the computer.



Downloading ANY program from the Internet or by other means when not directed by Rottler is prohibited and will result in the machine warranty being NULL and VOID.



Downloading any program or changing any Rottler or Computer settings may cause the machine and/or software to become unstable. DO NOT install ANY screen saver, Anti-Virus, Spyware or any type of Security software on the computer. This could create a hazardous environment for the operator and personnel around the machine. Performing any of the above will also result in the machine warranty being NULL and VOID.

**Master Power On/Off Switch**

This switch is located on the main electrical control enclosure on the right hand side of the machine. The switch must be in the off position before opening the rear enclosure door.

When first applying power to the machine the computer will need to boot up. Be patient, it will take several minutes to complete booting. The Rottler program will not automatically start. Double tap the Rottler\_WPF icon on the screen to start Rottler.

When turning the main power to the machine off there is a specific procedure to follow so as not to damage the computer. The computer must shut down its internal systems before main power is removed from it.

Press the "Start" button in the left-hand side of the Start Bar. This will bring up the "Start Menu". Press the "Shutdown" line at the bottom of the Start Menu. This will bring up a Pop Up menu, make sure that "shut down computer" is selected and press "OK".

This will shut down the computer. It is now OK to turn Main Power off to the machine.

## Initialization Screen

When the F107/9AHL is powered up the Rottler program will not automatically start. It may take several minutes for the computer to power. Start the Rottler program by double tapping the Rottler\_WPF icon on the desktop. Once the program is started, the Rottler Program Select will appear.

NOTE: Do not push any buttons or icons on the screen before the Rottler program starts or an error may be caused on the computer.

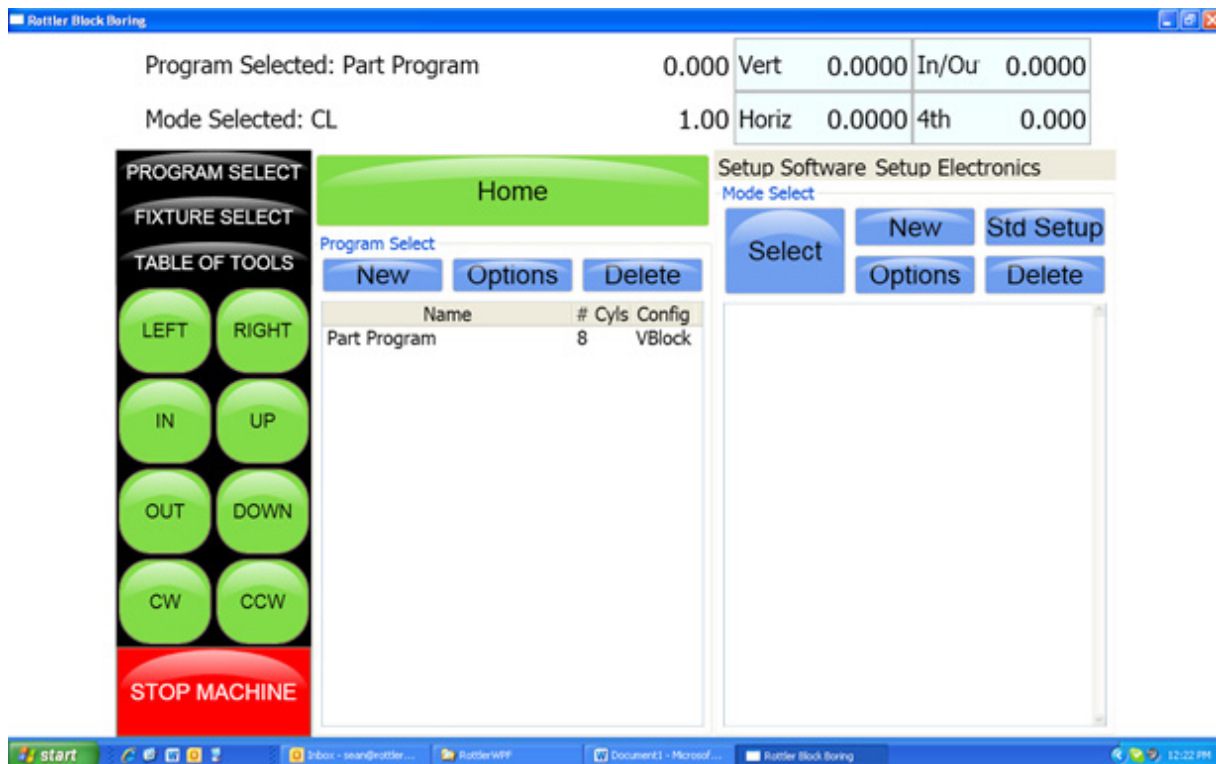

## General Information

The Rottler software operates on a Block Model format. You select or create the block you are working with. Then select or create an operation to be performed on that block.

### Home

Pressing this button will cause the machine to move all axis to their home (Machine Origin) position. The vertical will home first to be sure it is clear to move the other axis. The machine MUST be homed after it is turned on. This is how the machine gets its reference points to operate.

### Program Select

This is the left section of the screen. This is where you create and select blocks you will be working with.

## New

Pressing this in the Upper level will cause a dialog box to appear. Here is where you name and configure the block, the number of cylinders and Inline or V Block.

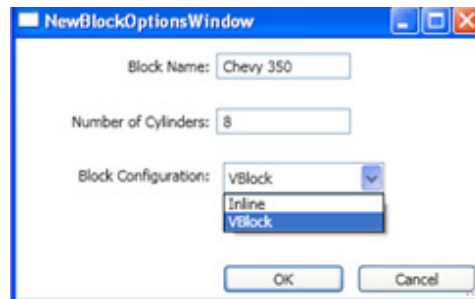

Pressing OK will result in the Block Model being inserted into the left hand side of the screen.



## Options

This will bring up the same dialog box as described above if any of the information needs to be changed.

## Delete

This will delete whatever block program is selected. A dialog box will appear to ask you if you want that program deleted.

## Mode Select

This is the right section of the screen. This is where you create or select operations to be performed on the selected Block. This area will be blank when you first create a block.

You can create only certain modes you will use on a block or use a standard set up that inserts all modes available. You can also create a new mode and rename it for a specific use.

### New

Pressing this button will bring up a dialog box with Rottler standard operations.

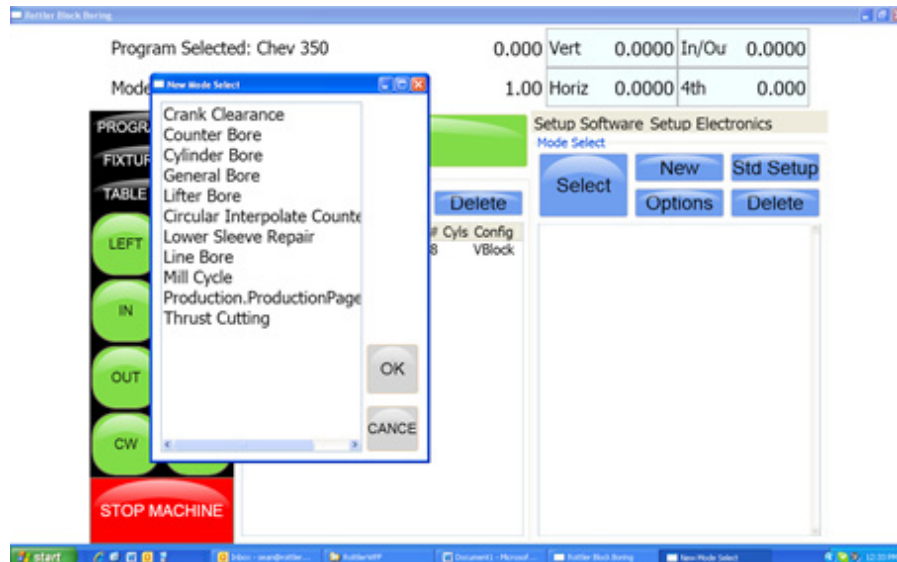

Select the operation you want to create and then press OK. This will place a general Bore operation under the Cylinder bore mode in the right hand section.



To enter General Bore mode highlight it and then press Select. This will take you to the operation screens that will be described later.

## Std (Standard) Setup

Pressing this button will insert all the Rottler operations into the right hand section automatically.



Use the slide bar on the right hand side to scroll through all the operations.

## Options

Press this button to bring up a dialog box to allow positive numbers to be entered in the horizontal stops. Most all programs are from left to right, the farther right you go the larger the negative number. However if a different zero point is used a positive number may be needed. For example, if you zero on the first cylinder on the left bank of a block and then "roll it over" the first cylinder is farther to the right than the zero position. Which would be a positive number.

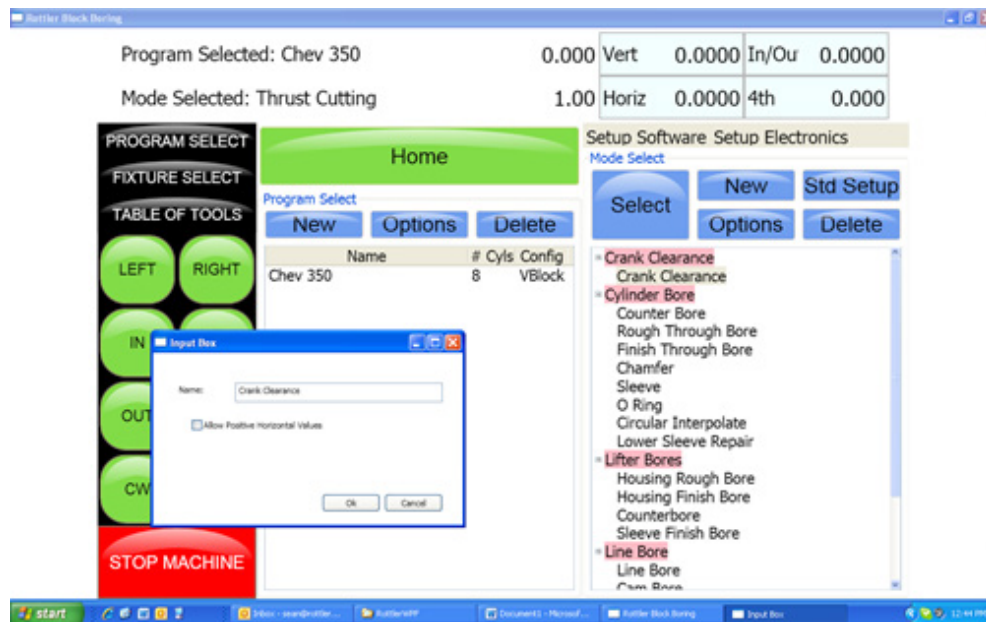

**Delete**

This will delete the selected Mode. It will ask you if you want this mode deleted before deleting it.

NOTE: Once the control definition for a particular button has been discussed it will not be repeated in the different modes of operation. Only new buttons or buttons with a different function will be discussed in different modes.

For these descriptions the Tool# and Probe # are not being used. They will be described later in this chapter.

**Basic Machine Controls**

**Fixture**

	Actual Position
X	0.0000
Y	0.0000
Z	0.0000

**Shows the linear position of the axis**

**SPINDLE** 36.04 **Shows the Position of the spindle in 0-360°**

**Double click to zero the axis**

**Click to move handwheel**

Handwheel: 0.010, 0.001, 0.0001

**Move To**

**Click to move to a position, a box that lets you enter the position will pop up**

**Notes**

0.0HP Drive 70F **Tool #:0** **Click to select the correct tool**

0.0HP Drive 70F **Set Active** **Used for ATC and setting proper tool offsets**



### Cylinder Bore, General Bore 3 Axis (without Tool Changer)

Each buttons function will be described in this section. In the different MODES, the same buttons will not be described again.

#### Set Zero Tab

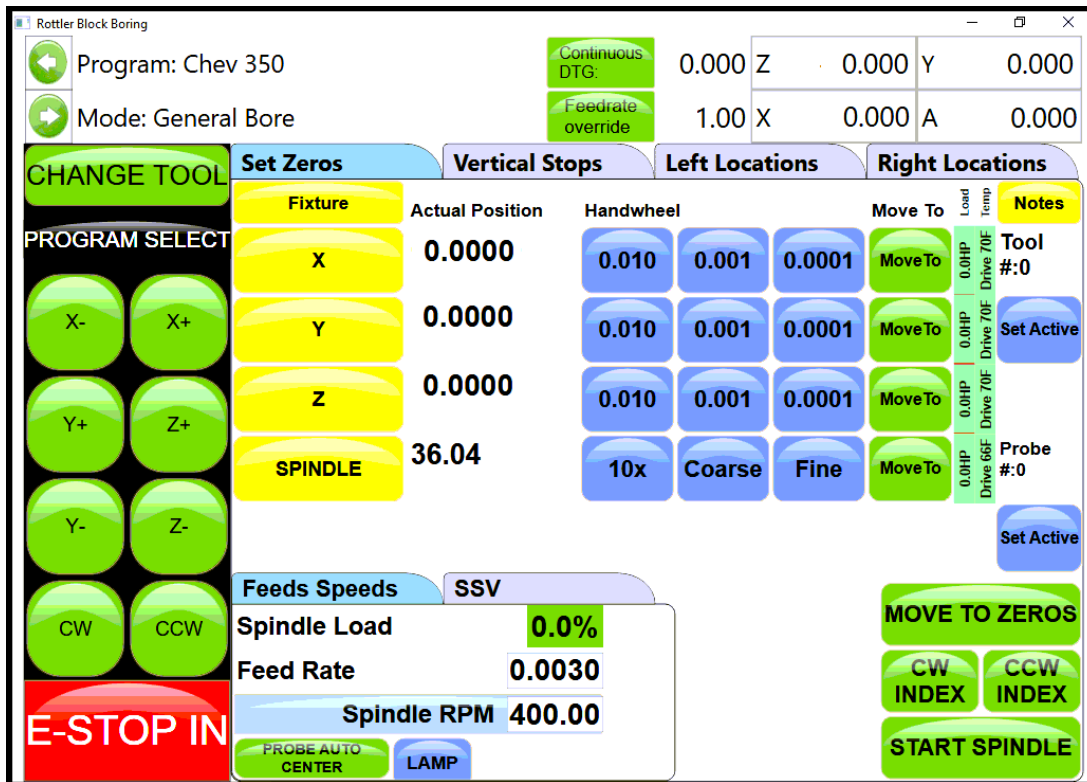

#### Actual Position

These are a numerical display showing the actual distance the axis are away from where they have been zeroed.

#### Velocity Override

The Velocity override is displayed in the upper left of the Actual Position display. The default is 100% of the programmed Feed Rate. When operating... turning the handwheel Counter Clockwise will override the axis rapid travel and feed rate 100 and 0% when in an automatic cycle.

#### Zero Buttons

These buttons will erase the actual position display of their associated axis and reset the displayed value to zero.

**Handwheel Buttons**

These buttons will activate their associated axis for use with the handwheel. The left button of each axis will move the machine in .010" per detent, the middle button .010" per detent and the right .0001" per detent of the handwheel. Pressing any of the axis Jog buttons will disengage the handwheel.

**Spindle Start**

This button will start the spindle at the RPM that is specified on the Auto Bore Cycle tab. Once the button has been pressed and the spindle is running the button will turn red and read Spindle Stop. Pressing the button again will stop the spindle and cause the button to go back to green.

**CW and CCW Creep**

These buttons will cause the spindle to rotate slowly CW or CCW direction. The spindle will continue to rotate as long as the button is pressed. The speed at which the spindle will rotate is set in the Machine Parameters and should not be changed unless instructed to do so by the factory.

**Jog Buttons**

These buttons control the rapid travel of the Vertical, Horizontal and In/Out axis. Pressing these buttons will allow you to move the machine through all ranges of its travel unobstructed. If the spindle is turned on these buttons become feed buttons and the machine will feed in whatever direction you have pressed. The rate at which the machine will feed is determined by the value set in the Auto Bore Cycle tab. When in rapid travel, these buttons are momentary contact and you will have to keep them pressed to keep the machine moving. When the spindle is on, they are latching buttons and once they are pressed the travel will continue until they are pressed again.

**Move to**

Pressing these buttons will bring up a dialog box for the associated axis. Enter a value that you want the axis to move to and press ENTER. That axis will then move to that position. You can do multiple "Move To" at the same time. One after another.

**Move To Zeros**

Pressing this button will cause the vertical to move the zero position first. The in/out and horizontal will move after the vertical has moved to zeros.

**CW and CCW Index**

Pressing either of these buttons will cause the spindle to rotate to the index position. Index position is with the tool to the right as you are facing the machine.

### Using SSV (Spindle Speed Variance)

Spindle Speed Variation (SSV) allows you to modify the spindle speed within a range causing it to continuously change. This changes the harmonic frequency of the machining, which can help in the appearance of chatter. Various issues can cause chatter: spindle speed, incorrect feeds, depth of cut, part rigidity, the type of part being machined, thin walls, or diameter-length ratio.

The screenshot shows the Rottler Block Boring control interface. At the top, the program is 'Chev 350' and the mode is 'General Bore'. The 'Continuous DTG' is 0.000 and 'Feedrate override' is 1.00. The main control area has buttons for 'CHANGE TOOL', 'PROGRAM SELECT', and 'STOP MACHINE'. The 'Set Zeros' section shows 'Actual Position' for X (0.0008), Y (0.0000), Z (0.0000), and SPINDLE (0.00). The 'Vertical Stops' section shows 'Handwheel' settings for X, Y, and Z (0.010, 0.001, 0.0001) and 'SPINDLE' settings (10x, Coarse, Fine). The 'Feeds Speeds' section shows 'SSV' options: 'Enable SSV' (checked), 'Time per Cycle' (0.5000), and 'RPM variation' (200.0000). The 'Right Locations' section shows 'Move To' buttons for X, Y, Z, and SPINDLE, and 'Notes' for Tool #4 and Probe #4. The 'SSV' menu is highlighted with an orange border and a red arrow points to it.

Checking enable SSV- will engage it for the machining process you are doing

Time per Cycle- each cycle is measured as a second.

RPM Variation- How much the rpm can vary up and down from what you set in the program

(NOTE: setting this too extreme can cause Spindle errors and spindle crashes.)

## IMPORTANT

### Setting Spindle Index

Any time the machine has been turned off the spindle index position must be set. Turn the spindle to the index position (tool holder facing to the right at 90 degrees from the operator). Then press the Zero button net to the spindle position read out. This will put a zero value in the display box.

This screen also shows the Spindle Load, programmed Feed Rate and Spindle RPM.

### Probe Auto Center

The Probe is an option on the F103/4/5A machine. When this button is pressed a single Probing routine will be run in the position the machine is currently at.

## Vertical Stops Tab

This screen is used to set the Vertical stops the machine will use to bore a cylinder. There are four Vertical stops used on this screen plus two optional Lower Clearance stops.

If the machine is equipped with a probe there are two (2) additional stops, Probe Clearance and Probe Height.

The function of the Vertical stops will be defined in the Operating Instructions chapter in this manual.

To enter any of the Vertical Stops press the Data box next to the Vertical stop you want to enter. A pop-up menu will appear. Press the desired numerical value and then press ENTER. The numerical data will then appear in the data box. You can also move the Vertical physically to the location you want the stop to be at and press the "SET" button next to the Data Box. This will take the current position from the Digital read out and insert it into the associated Data Box.

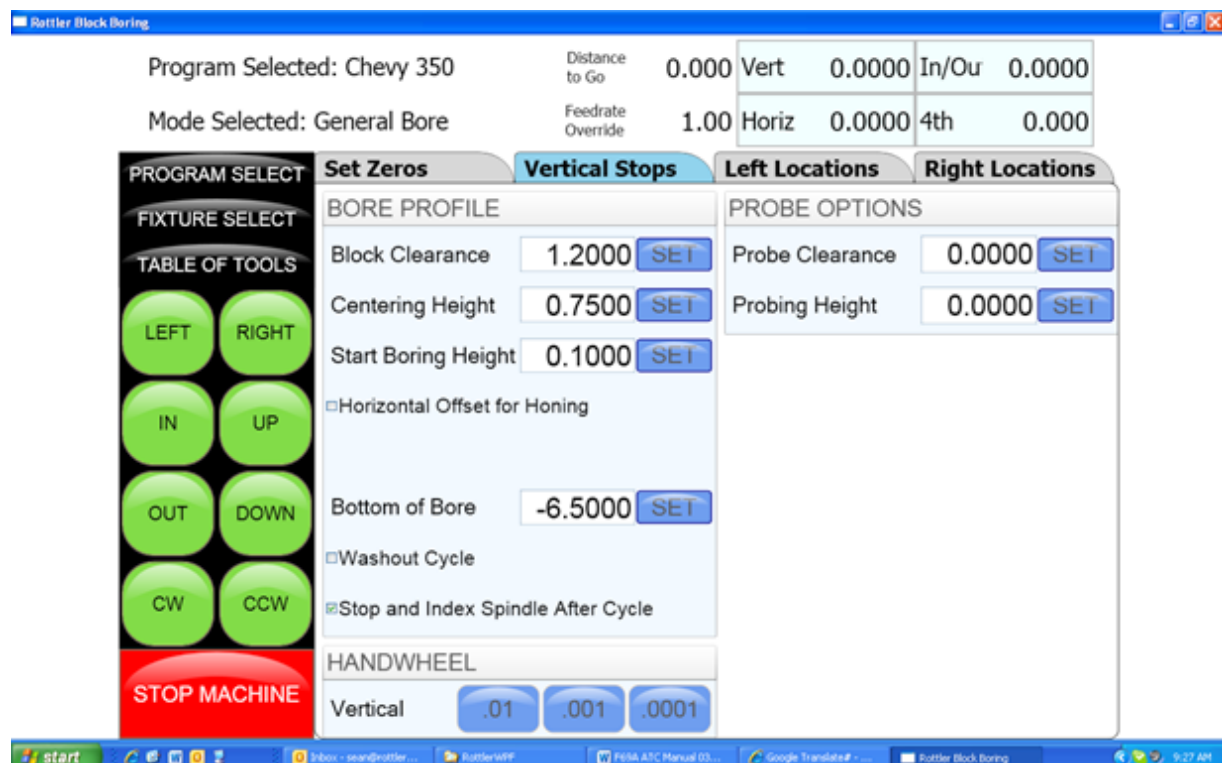

### Horizontal Offset for Honing

There is often the need to machine out the “webbing” at the bottom of a cylinder to get the correct honing clearance. Checking the box next to “Horizontal Offset for Honing” will bring up an additional screen section on the lower right.

This is where you will set the amount, direction and speed the offset will cut.



## Left and Right Locations Tab

This screen is used to set the Horizontal and In/Out stops the machine will use to bore a block. The number of In/Out and horizontal stop on this page will change with the block configuration i.e V6, V8 or inline.

The function of the Horizontal and In/Out stops will be defined in the Operating Instructions chapter of this manual.

To enter any of the Horizontal and In/Out stops press the Data box next to the Horizontal or In/Out stop you want to enter. A pop-up menu will appear. Press the desired numerical value and then press OK. The numerical data will then appear in the data box

## Cylinder Bore – Bore Locations



There are three (3) different modes you can operate the machine in on these screens, Blueprint, Indicated and Probing.

### Blueprint

This mode of operation allows you to enter specific values for the bore locations from a blueprint type document.

It is helpful to have the blue print numbers entered on this screen even if you are not going to bore to the blueprint locations on a particular block. They help to set the general area of the bore if you are manually centering (indicating) or probing the block.

### Move Buttons

When pressed, these buttons will move the machine, under power, to the Horizontal and In/Out positions shown in the data boxes below the Move button. The Vertical will move to the Clearance height before it makes the Horizontal or In/Out moves. After it has moved to the Horizontal and In/Out positions the Vertical will move to the Centering Height. After this, all motion stops.



## Bore Buttons

Pressing this button once will cause it to turn yellow. This indicates when the “Bore Left” button is pressed this cylinder will not be bored.

Touching this button again (with a pause in between touches) will turn the button back to green. All green bores will be bored if the “Bore Left” button is pressed. The control will ask you if you sure you want to bore the selected bores.

Double Clicking a Bore button will keep it green and turn all other bore buttons yellow.

## Indicated

This screen is designed to manually indicate each cylinder in for it's specific location.



## Set Buttons

Once a cylinder has been indicate, pressing the associated Set Button will take the current machine position and place the values in the Data Box associated with that cylinder.

## Copy Values

Pressing this button will bring up another window where you can select to copy the In/Out and Horizontal values from Blueprint, Indicated or Probed screen.

## Difference

Checking this Box will cause a green check mark to be placed in the box. The Data Boxes will then display the difference in values from the blueprint screen to the indicated screen. This is helpful to know how far the cylinders actual location is from blueprint values.

## Bore Left and Right

Pressing this button will cause the entire Left or Right bank to be bored automatically. The Bore buttons that are yellow will not be bored though.

## Probing

The probe is an option on the F103/4/5A machine.

This screen is designed to automatically probe one or all of the cylinders.



### Probe Buttons

Pressing this button will cause a probing routine to be run on the associated cylinder.

### Probe Left or Right

Pressing this button will cause the entire Left or Right banks to be probed automatically.

### Probed Diameter

This Data Box will display the diameter of the cylinders as they are probed.

## LOWER SLEEVE REPAIR

Lower Sleeve repair is meant to be used when the Upper Bore is smaller in Diameter than the Lower Bore. Therefore the spindle has to offset in the Horizontal to clear the Upper Bore.

The Lower Sleeve Repair mode operates the same as the Cylinder Bore Mode with the exception of additional parameters in the Vertical Stops Tab.

### Block Clearance

This is the distance above the zero position or block deck allowing the cutter head to move to the next bore unobstructed. If you are blueprinting a block the number will be just enough to allow the tool in the cutter head to clear the block deck.



### Centering Height

This is a distance above the vertical zero where you will be manually centering the block. The drawing below is a typical set up for manual centering or indexing a cylinder.

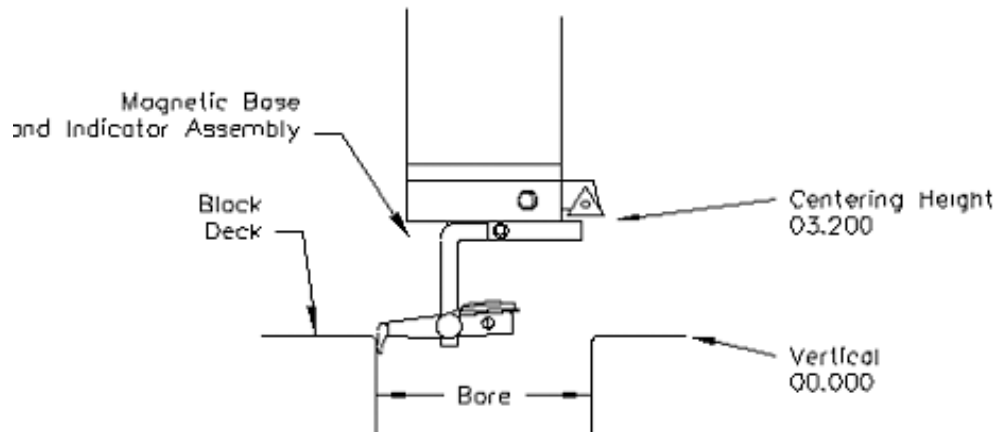

### X-Clearance

This is the parameter will index the cutter pointing in the x+ direction, (right) three O'clock position. The amount you set will allow the tool to move so it clears the block deck of the upper bore does not contact the block or upper bore. See drawing below. Machine moves in the X axis, and can be set to positive or negative movement. Should be set to negative value ex... -.200 (-5mm)

#### 180 index (check box)

This will make the spindle index with the tool pointing in the (X-) direction, (left) nine O'clock position. Should set X-clearance to a positive value, ex... .200 (5mm)

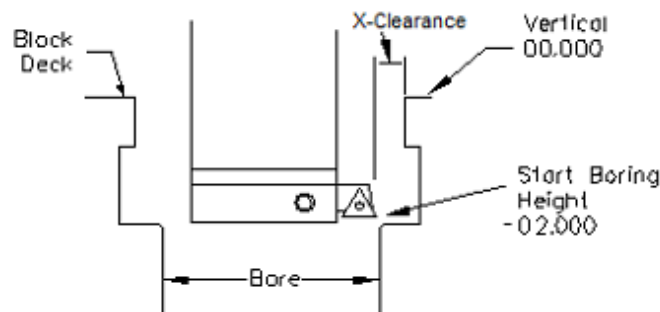

### X-Overshoot

This refers to the amount that it will overshoot the machine to help eliminate any backlash. IMPORTANT- If your X-clearance is negative (-) the overshoot should be a positive value, if the X-clearance is positive the overshoot should be negative (-)

### Start Boring Height

This is the distance above zero or the block deck where you want the cutter head to start rotating and the downward feed to start. Generally this is just a short distance above the lower sleeve to minimize the amount of time the machine bores through air.

**Bottom of the Bore**

This is the distance below zero or the Block deck where you want the machine to stop boring and retract out of the cylinder. When the spindle retracts it will then go to the Block Clearance position.

This is an example of what the above program would look like on the vertical stops.

**Stop and Index Spindle after Cycle**

Checking this box will cause the spindle to be indexed to the three O'clock position after the cylinder has been bored but before it retracts. It will also offset to the left before the tool is retracted. This is the default setting. You would not want this check in an operation such as Lifter Boring.

## Probing For The Mill Cycle

The Rottler Milling program is set up to Automatically Probe the Deck height of a block and then Mill it to a set Deck Height. This can be done on a 3 or 4 axis machine. This will also cover Setting Tool Offsets.

### Table of Tools for Milling

You **MUST** use the Table of Tools if you want to Automatically Probe the deck height and cut it to a set height. Once done the Table of Tools Should look similar to the below picture. The 100mm Probe is Tool 1. The 10" Fly Cutter is Tool 2.

Go to Program Select, and then select the block you are working with and then Mill Mode.

Install the Probe physically into the spindle. If you have a 4th axis rotate it to Zero degrees. Indicate the Middle flat on the head stock to be sure it is zero all the way across. There should be a number stamped into the headstock.

This is the distance from the Flat to the center of the Crank. Bring the probe down until it just touches the middle flat.

Open the Table of Tools and double click on Tool1 100 mm Probe. Enter the Measured diameter of your probe. This is not used in the Milling Program but needs to be entered accurately for Probing in the Bore mode.

On the open window select Get Length. This will open another Window. There will be a value, that you cannot edit, in the "Z Location from Zero" this is the distance the Vertical Axis is from home when the Probe touches the Middle flat.

In the Data box for "Z Touch off Height" enter the number that is stamped on the Head Stock. This is the distance from the flat to the center line of the Crank.

The screenshot displays the CNC control interface. At the top, the 'Program: Part Program' and 'Mode:' are visible. Below this, there are several control buttons: 'Continuous DTG: 0.000', 'Feedrate override: 1.00', and a coordinate display showing Z: 0.0000, Y: 0.0000, X: 0.0000, and A: 0.000. The 'Table of Tools' window is open, showing a list of tools with columns for 'TC Pocket', 'Tool Diam.', 'Tool Length', 'Type of Tool', 'Description', and 'Toolheight'. The first tool is highlighted in red. Below the table, there are buttons for 'Add Tool', 'Remove Tool', 'Set Active Tool', 'Set Active, who moving to TC position', and 'Load ATC'. In the foreground, a 'Get Length' dialog box is open, showing fields for 'Z Location from Zero' (0.000), 'Z Touch off Height' (0.000), and 'Final Tool Length' (0.000). There are also 'OK' and 'Cancel' buttons. At the bottom of the screen, there are four green buttons labeled 'Y-', 'Z-', 'CW', and 'CCW'.

Select OK on both windows. This will put the Total tool length into the Table of Tools.

The Vertical Digital Read Out will now consider the center of the Crank bore to be the Vertical Zero position. When the Probe tip or Cutting insert touches the Deck the Vertical DRO will be reading out the distance from the center of the Crank bore (Actual Deck Height).

### Assigning Tools

From the Set Zero Tab, select Probe#. This will open the Tools Select Form. Select Tool 1, 50 mm Probe and click OK.

Select the Tool#.

This will open The Tool Select Form. Select Tool 2, 10 inch Fly Cutter and click OK.



The tools to be used have now been assigned to the program.

### Left Deck Probe

Enter the positions you want the Probe to probe here. You can physically move the probe to the locations on the bank you want to probe and hit the set button also.

### Right Deck Probe

Roll the block over to the Right Bank. Enter the positions you want the Probe to probe here. You can Physically move the probe to the locations on the bank you want to probe and hit the set button also.

### Auto Probing

Press the Start Probing button. The machine will first probe each programmed location on the left bank and record the height. The spindle will move to Vertical Clearance height and the block will roll over to the right bank and probe the programmed locations and record them. If you have a 4th axis The block will then roll back over to the Left bank and the spindle will move to the first Left location and stop.

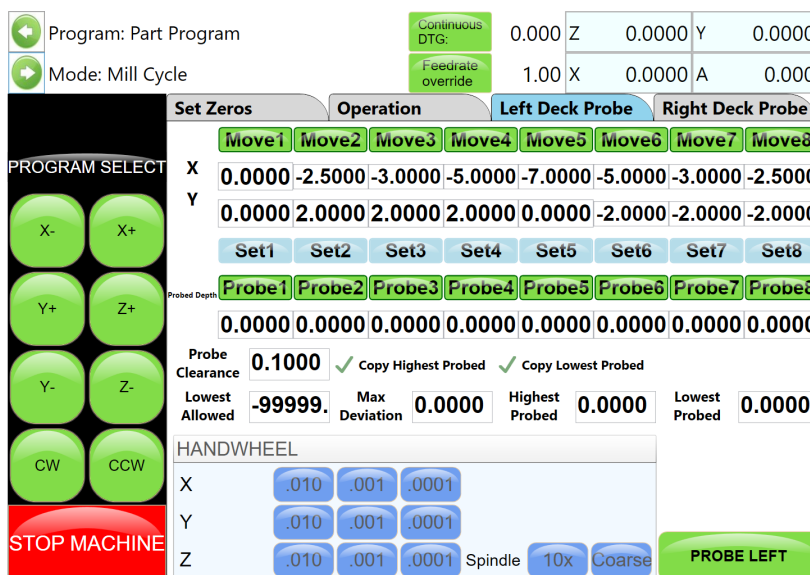

## Lifter Bore

The Lifter Bore Mode and its buttons operate identical to the Bore Mode with a couple of exceptions.

On the Program Vertical Stops screen, lower Clearance Offset is not an option.

After a bore is complete the spindle will not offset .020" for tool clearance unless the "Horizontal Offset after Cycle" box is checked. This is used when a single point boring tool is used for lifter boring.

## Cylinder Bore 4 Axis

Most of the Control Definition in the 4th axis is the same as the 3 axis version of software. Only the differences or new features will be discussed in this section.

### Set Zero Tab

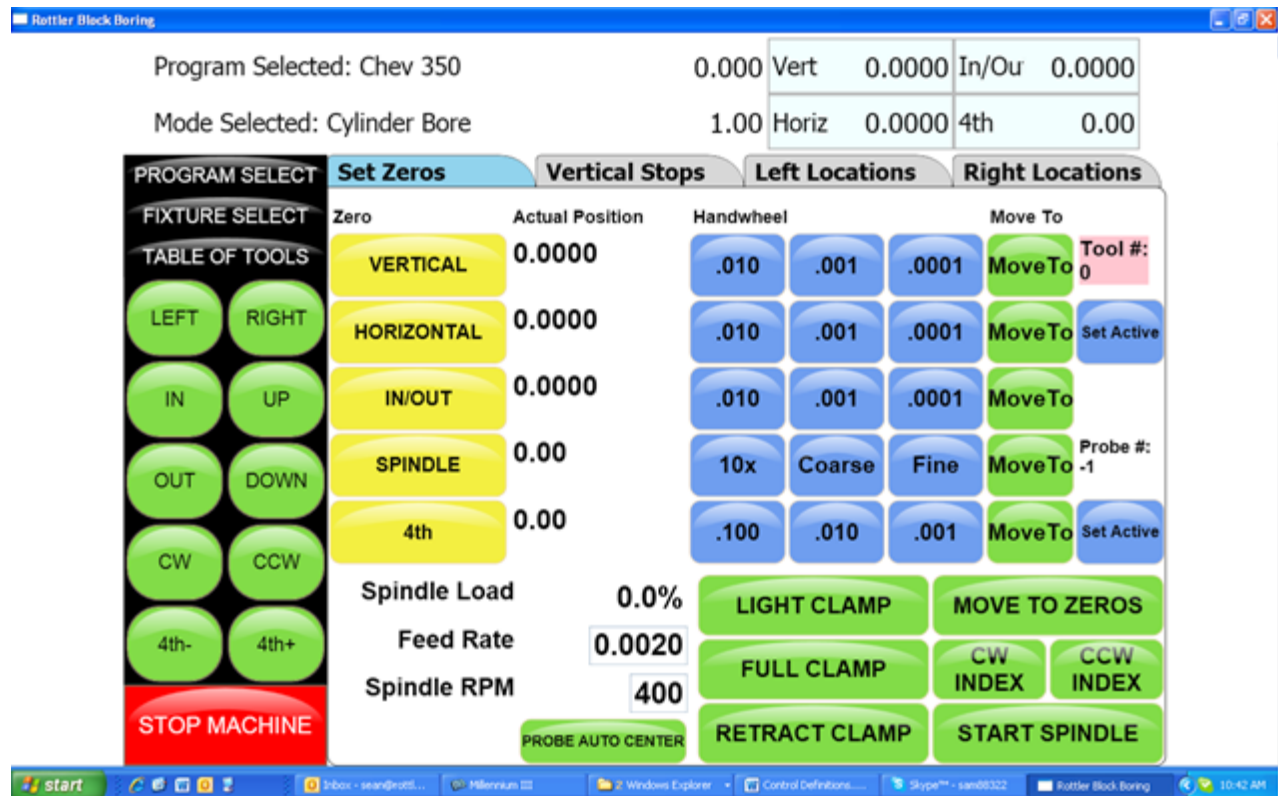

## Jog Controls

### 4Th-

Pressing this button will cause the 4th axis to rotate in a negative direction while held.

### 4Th+

Pressing this button will cause the 4th axis to rotate in a positive direction while held.

### 4th Axis Degree and Move

Touching the 4th Axis Degree Data Box will bring up a Pop-Up Menu so a degree can be entered. Once a value is entered (even zero), pressing the Move button will move the 4th axis to that position.

**4th axis Brake**

This shows the status of the 4th axis brake as well as manually turning the brake on and off. When the 4th axis is rotated using the jog controls the fixture will automatically switch the brake On and Off.

**Light Clamp**

Pressing this button will cause light pressure to be exerted from the Tail Stock towards the Head stock. When the 4th axis is rotated using the jog controls the fixture will automatically switch from Full to Light clamp and back.

**Full Clamp**

Pressing this button will cause full pressure to be exerted from the Tail Stock towards the Head stock.

**Retract**

Pressing this button will cause the tail stock to fully retract. A dialog box will appear when this button is pressed to assure you want to retract the tail stock. This is to prevent an accidental retraction when a block is in the fixture.

## Table Of Tools

The Table Of Tools is a very powerful feature in this software. Most of the Rottler programs are designed to be used without interacting with the Table Of Tools.

Only the program specific uses will be described here.

### Table Of Tools General Information

The Table Of Tools is used to set different tool lengths so multiple tools can be used in one program and reference the same vertical zero position.

For Example, if you were to use two boring bars in one program. One boring bar is 8" long and the other is 4" long. There is then a 4" difference in where the cutter of each bar will come into contact with the part to be machined. Using the Table of Tools you can set the 4" difference for one of the boring bars so that both of the cutting tools will come into contact with the material at the same vertical position.

### Accessing Table Of Tools

Select TABLE OF TOOLS from any screen in the upper left hand corner. This will open up the Table Of Tools.

On this screen you will be able to Add, Remove or Set that tool Active (installed in spindle and being used).



The Table of Tools comes with Tool 0 installed with no offset amount. Tool 0 will remain tool 0 with no offset always. Tool 0 will be set active when you are using programs that do not require tool offsets.



### Add Tool

To add a tool to the Table of Tools press Add Tool. This will open another window. Here you will name the Tool you are adding. Such as 2.9 production Stub. It is important to give an accurate name to the tool. You want the tool easily identifiable by its name. The only other data box the Rottler software uses is the Length Data Box. This will be discussed later. Press OK.



The Added tool will now show in the Table of Tools.

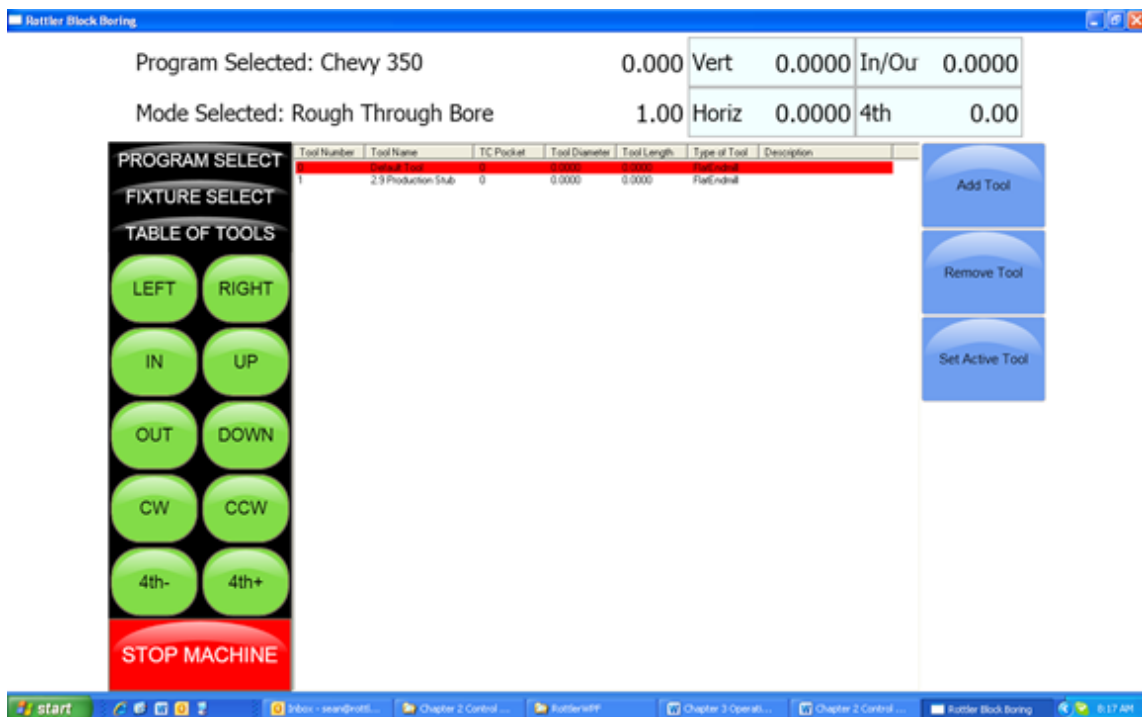



## Remove Tool

Pressing this button will remove the highlighted tool from the Table of Tools.

## Set Active Tool

Pressing this button will set the highlighted tool to an Active Status (tool installed and will be used) Any Vertical offset associated with that tool will be used when a program is run. You can tell which tool is active because it is highlighted in Red. When no offset is required in a program Tool 0, Default Tool should be active.

When setting a tool active another window will open. This is the Tool Change Form. It is basically there to verify the tool information before it is set to an active status. Verify the information and press OK.

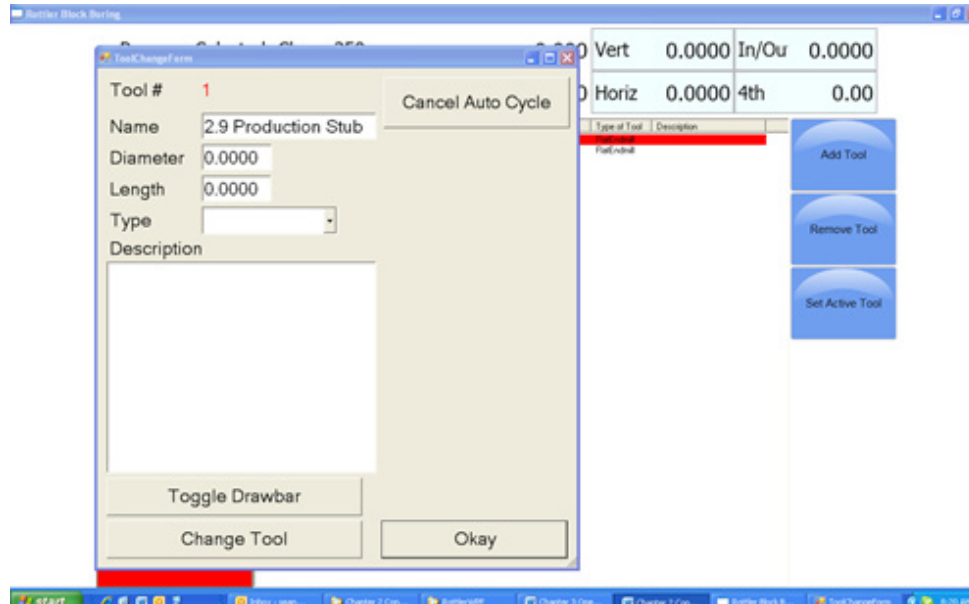

This window will open when the machine does an automatic tool change. This will be discussed in Chapter 5 Operating Instructions. After you press OK another window will open. This is a Warning Dialog box to inform the operator of the possibility of the spindle start if the tool change is done in an automatic program. Press OK.

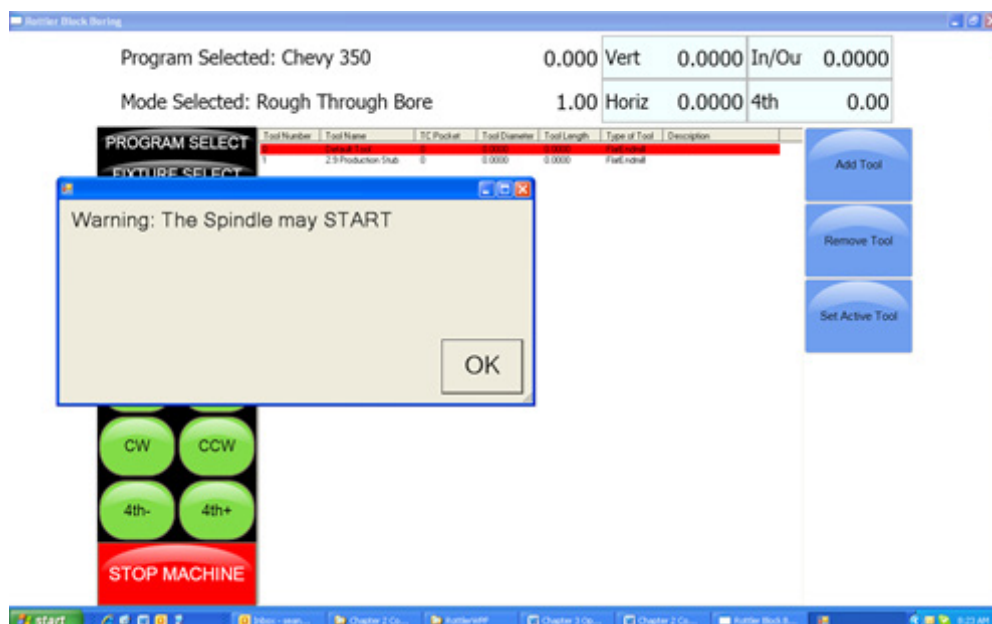

## Setting Tool Offsets

Add all the tools that will need offsets into the table of tools. Leave the Length value at 00.00 when you first enter them.

For this example we will be setting offsets for a 2.9 Production Stub, 100mm Probe and a 10 inch Fly cutter. Add these tools to the table of Tools.

**NOTE: Only the Probe will use the Tool Diameter. The Probe will use the Tool Diameter when probing a cylinder, it will not use the Tool Diameter when touch off a surface such as a block deck. Changing this setting will be discussed in later in this Chapter.**

The screenshot shows the Rottler Block Boring control interface. At the top, it displays the program selected as 'Chevy 350' and the mode as 'Rough Through Bore'. Below this, there are input fields for tool offsets: '0.000 Vert 0.0000 In/Ou 0.0000' and '1.00 Horiz 0.0000 4th 0.00'. A 'TABLE OF TOOLS' is visible, listing three tools: '2.9 Production Stub', '100mm Probe', and '10 inch Flycutter'. A control panel on the left includes buttons for 'PROGRAM SELECT', 'FIXTURE SELECT', 'TABLE OF TOOLS', and directional controls (LEFT, RIGHT, IN, UP, OUT, DOWN, CW, CCW, 4th-, 4th+), along with a 'STOP MACHINE' button. On the right, there are buttons for 'Add Tool', 'Remove Tool', and 'Set Active Tool'. The Windows taskbar at the bottom shows the start button and several open applications.

Tool Number	Tool Name	TC Pocket	Tool Diameter	Tool Length	Type of Tool	Description
1	2.9 Production Stub	0	0.0000	0.0000	FlatEndmill	
2	100mm Probe	0	0.2000	0.0000	FlatEndmill	
3	10 inch Flycutter	0	0.0000	0.0000	FlatEndmill	

To set Tool Offsets you will need a fixed vertical reference point on the machine that does not change such as the head stock of the 4th axis or Performance Fixture.

Install the first tool such as the 2.9 Production Stub with Cutting insert installed. Bring the cutting insert down until it just touches the flat on the head stock of the 4th axis fixture. Go to the TABLE OF TOOLS and double click the 2.9 Production Stub tool. Select Get Length from that window. This will bring up the Tool Length window.

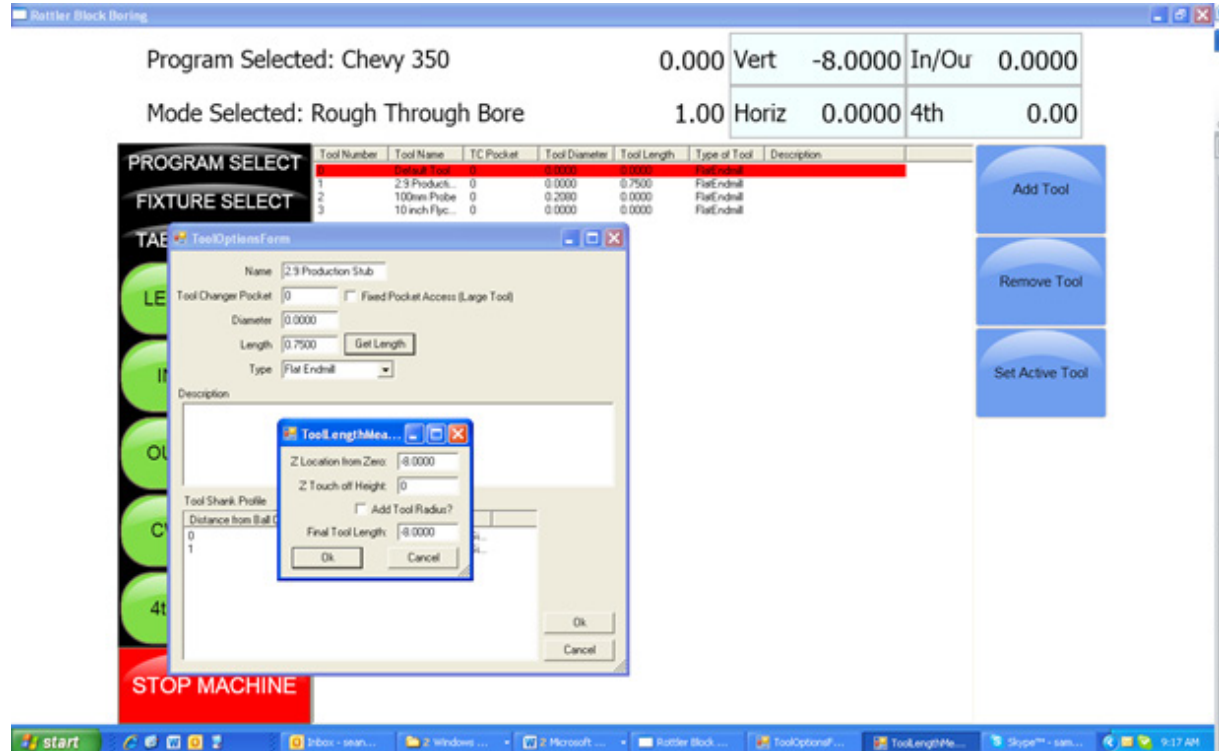

### Z Location from Zero

This is the distance the Vertical Axis is from the home position. NOT where the operator has set the Vertical Zero in the program. This value is set by the computer automatically. In this example the tool just touched the flat at 8.0000.

### Z Touch Off Height

This value is an additional value you want added to the Z location from zero. For example, if you wanted to use the center of the Crankshaft as the vertical reference point, but you are touching the tool off of the flat of that head stock, you would enter the distance from where you are touching off to the center of the Crank (this value is stamped into the headstock by Rottler). The values from Z Location from Zero and Z Touch off Height are added together by the computer to get the Final tool Length value. If you are not referencing another vertical position then this value will remain 00.000.

### Add Tool Radius?

Checking this box will add the Tool Radius to the Final Tool Length. This is not used in the Rottler programs and should remain unchecked for all tools.

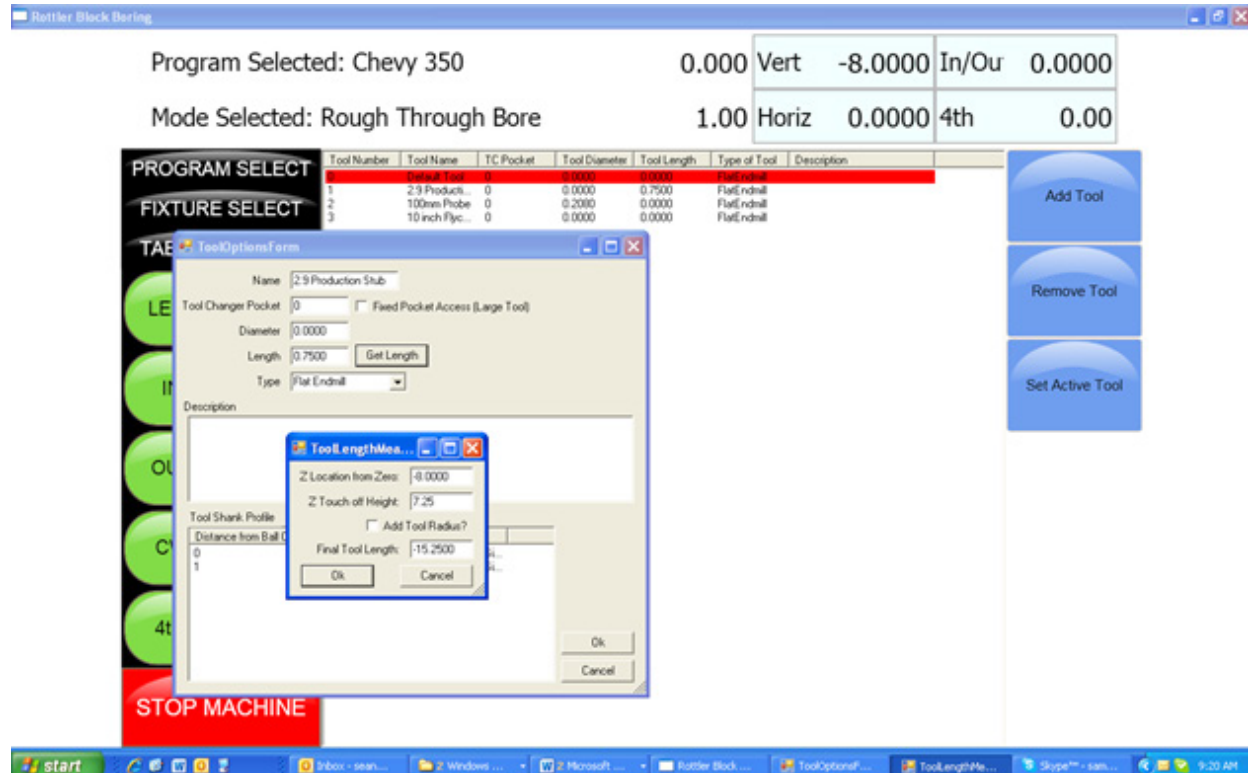

Repeat this procedure for each tool. Touch ALL of them off from the same point.

When running a Rottler program the cutting insert for each tool will reference the Vertical Zero the operator set in the program and come into contact with the surface to be machined at the same vertical value.

### Applying Table of Tools to Rottler Programs

The use of the Table of Tools to specific Rottler programs such as Bore and Mill will be defined in Chapter 5 Operating Instructions.

### Fixture Select

This is also a very powerful tool. It is not generally used in the Rottler Programs. It's basic function is to offset a program and table of tools a set distance on each axis (if desired) and run the same program without resetting axis zero points.

For example, if you have to fixtures that are identical but are set at a different location on the table you can set the difference values in the table of fixtures and run the program.

It is recommended this is not used unless you are a very experienced operator.

# OPERATING INSTRUCTIONS

## Contents

<b>Operating Instructions .....</b>	<b>5-1</b>
<b>Loading Blocks .....</b>	<b>5-1</b>
<b>Small Gas and Diesel .....</b>	<b>5-1</b>
Manual V6/V8 Combination Fixture 502-1-72H .....	5-1
Boring Application .....	5-1
<b>Normal Operating Procedure .....</b>	<b>5-3</b>
Surfacing Application .....	5-5
<b>Normal Operating Procedure .....</b>	<b>5-7</b>
<b>Retrofitting 502-1-15C Parallels to V6/V8 Combination Fixture .....</b>	<b>5-8</b>
<b>Diesel Blocks .....</b>	<b>5-10</b>
<b>6725 Diesel Fixture .....</b>	<b>5-10</b>
Small Diesel V Blocks .....	5-10
Triangle Clamping .....	5-11
Block Clamp Arm .....	5-11
<b>Small Diesel In Line Blocks .....</b>	<b>5-13</b>
Triangle Clamping .....	5-14
<b>6405F Large V-Block .....</b>	<b>5-16</b>
Triangle Clamping .....	5-17
<b>6810 Waukesha 7042, 9390 and CAT 379, 398, 399 Block Line Bore Fixture .....</b>	<b>5-21</b>
<b>6821 Adjustable, Universal Line Bore Parallel Assembly .....</b>	<b>5-25</b>
<b>7119V Dual Axis Table Assembly .....</b>	<b>5-30</b>
Instructions for Small In-Line Blocks .....	5-31
Mounting Block to Table .....	5-31
Blocks with Main Caps Removed or Raised Main Bearings .....	5-31
Blocks with Main Caps Installed .....	5-32
Typical Head Set Up Procedure .....	5-33
<b>12" Multi Tooth Milling Head - 6865 .....</b>	<b>5-36</b>
<b>18" Multi Tooth Milling Head 6864 .....</b>	<b>5-36</b>
<b>Right Angle Drive Installation .....</b>	<b>5-37</b>

<b>General Machine Information</b> .....	<b>5-41</b>
<b>Homing</b> .....	<b>5-41</b>
<b>Building Programs</b> .....	<b>5-41</b>
<b>Create a Block Program</b> .....	<b>5-41</b>
New.....	5-41
<b>Options</b> .....	<b>5-42</b>
<b>Creating Operating Modes for a Block Model</b> .....	<b>5-42</b>
<b>New</b> .....	<b>5-43</b>
<b>Std (Standard) Setup</b> .....	<b>5-44</b>
<b>Select</b> .....	<b>5-44</b>
<b>Options</b> .....	<b>5-44</b>
<b>Cylinder Bore Mode 3 Axis</b> .....	<b>5-45</b>
Setting Zeros .....	5-46
Horizontal and In/Out Zero .....	5-46
Vertical Zero .....	5-46
<b>Blueprinting</b> .....	<b>5-48</b>
<b>Programming Vertical Stops</b> .....	<b>5-48</b>
<b>Block Clearance</b> .....	<b>5-48</b>
<b>Centering Height</b> .....	<b>5-49</b>
<b>Start Boring Height</b> .....	<b>5-49</b>
<b>Bottom of the Bore</b> .....	<b>5-49</b>
<b>Horizontal Offset for Honing</b> .....	<b>5-50</b>
<b>Start Offset Height</b> .....	<b>5-50</b>
<b>Horizontal Offset</b> .....	<b>5-50</b>
<b>Change Speeds at Horizontal Offset</b> .....	<b>5-50</b>
<b>Washout Cycle</b> .....	<b>5-50</b>
<b>Stop and Index Spindle after Cycle</b> .....	<b>5-50</b>
<b>Bore Locations</b> .....	<b>5-51</b>
<b>Left Locations</b> .....	<b>5-52</b>
<b>Right Locations</b> .....	<b>5-52</b>

<b>Boring a Block .....</b>	<b>5-53</b>
<b>Indicating.....</b>	<b>5-53</b>
<b>Vertical Zero .....</b>	<b>5-53</b>
<b>Programming Vertical Stops .....</b>	<b>5-54</b>
<b>Block Clearance.....</b>	<b>5-54</b>
<b>Centering Height.....</b>	<b>5-55</b>
<b>Start Boring Height.....</b>	<b>5-55</b>
<b>Bottom of the Bore .....</b>	<b>5-56</b>
<b>Bore Locations .....</b>	<b>5-57</b>
<b>Boring a Block .....</b>	<b>5-59</b>
<b>Probing.....</b>	<b>5-59</b>
<b>Vertical Zero .....</b>	<b>5-59</b>
<b>Programming Vertical Stops .....</b>	<b>5-60</b>
<b>Block Clearance.....</b>	<b>5-60</b>
<b>Centering Height.....</b>	<b>5-60</b>
<b>Start Boring Height.....</b>	<b>5-60</b>
<b>Bottom of the Bore .....</b>	<b>5-61</b>
<b>Probe Height .....</b>	<b>5-61</b>
<b>Bore Locations .....</b>	<b>5-62</b>
<b>Probe Auto Center .....</b>	<b>5-62</b>
<b>Automatic Probing Procedure.....</b>	<b>5-62</b>
<b>Boring a Block .....</b>	<b>5-63</b>
<b>Cylinder Bore Mode 4th Axis.....</b>	<b>5-63</b>
<b>Setting Zeros .....</b>	<b>5-63</b>
<b>4th Axis (Rotational) Zero .....</b>	<b>5-63</b>
<b>Finding the In/Out (Y) Axis Zero with 4th Axis.....</b>	<b>5-63</b>
<b>Building Programs with the 4th Axis.....</b>	<b>5-63</b>
<b>Setting Vertical Clearance with 4th Axis .....</b>	<b>5-64</b>
<b>Table of Tools for 3 and 4th Axis Bore Mode .....</b>	<b>5-64</b>
<b>Building a Program with Table of Tools .....</b>	<b>5-64</b>

<b>Assigning Tools</b> .....	<b>5-64</b>
<b>Setting Tools Active</b> .....	<b>5-65</b>
<b>Mill Mode 3 Axis</b> .....	<b>5-67</b>
<b>Setting Zeros</b> .....	<b>5-67</b>
Horizontal Zero.....	5-67
In/Out Zero .....	5-67
Vertical Zero .....	5-67
Example .....	5-67
<b>Mill Operation</b> .....	<b>5-69</b>
<b>End</b> .....	<b>5-69</b>
Horizontal End.....	5-69
Amount Per Pass .....	5-69
Vertical Start .....	5-69
Vertical End .....	5-69
Copy Lowest Copy Highest .....	5-70
<b>Rough Settings</b> .....	<b>5-70</b>
Rough Feed Rate .....	5-70
Rough Spindle RPM.....	5-70
Finish Cut Settings .....	5-70
Finish Amount .....	5-70
Finish Feed Rate .....	5-70
Finish RPM .....	5-70
<b>Start Auto Cycle</b> .....	<b>5-71</b>
<b>Mill Mode 4th Axis</b> .....	<b>5-71</b>
<b>Setting Zeros</b> .....	<b>5-71</b>
Horizontal Zero.....	5-71
In/Out Zero.....	5-71
Vertical Zero .....	5-71
<b>Mill Operation</b> .....	<b>5-73</b>
<b>End</b> .....	<b>5-73</b>
Horizontal End.....	5-73
Amount Per Pass .....	5-73
Vertical Start .....	5-73
Vertical End .....	5-73
Copy Lowest Copy Highest .....	5-74



<b>4th Axis Angles .....</b>	<b>5-74</b>
Left Bank Angle.....	5-74
Right Bank Angle .....	5-74
Rollover Vertical Clearance.....	5-74
In/Out Offset .....	5-74
<b>Rough Settings .....</b>	<b>5-74</b>
Rough Feed Rate .....	5-74
Rough Spindle RPM.....	5-74
<b>Finish Cut Settings .....</b>	<b>5-74</b>
Finish Amount .....	5-74
Finish Feed Rate .....	5-74
Finish RPM .....	5-74
<b>Cut Left and Cut Right .....</b>	<b>5-75</b>
<b>Start Auto Cycle.....</b>	<b>5-75</b>
<b>Milling Using Automatic Deck Probing.....</b>	<b>5-76</b>
<b>Table of Tools for Milling.....</b>	<b>5-76</b>
<b>Assigning Tools .....</b>	<b>5-78</b>
<b>Setting Tools Active .....</b>	<b>5-79</b>
<b>Building a Program Using Table of Tools.....</b>	<b>5-79</b>
Left Deck Probe.....	5-80
Right Deck Probe .....	5-80
<b>Auto Probing.....</b>	<b>5-80</b>
<b>Auto Milling .....</b>	<b>5-81</b>
Vertical Start .....	5-81
Vertical End .....	5-81
Cut Left or Cut Right.....	5-81
Start Auto Cycle .....	5-81
<b>Lifter Bore Mode 3 Axis.....</b>	<b>5-82</b>
In / Out Zero .....	5-82
Start Boring Height .....	5-82
Lifter Bore Angle .....	5-82
<b>Lifter Bore 4th Axis.....</b>	<b>5-83</b>
Start Boring Height .....	5-83
Lifter Bore Angle .....	5-83
Calculate In/Out.....	5-83

<b>Line Bore Mode</b> .....	<b>5-84</b>
<b>Mounting and Aligning the 90 Degree Head</b> .....	<b>5-84</b>
<b>Setting Zeros</b> .....	<b>5-84</b>
Horizontal Zero.....	5-85
In/Out and Vertical Zero.....	5-85
<b>Programming Vertical Stops</b> .....	<b>5-86</b>
<b>Bore Centerline</b> .....	<b>5-86</b>
<b>Block Clearance</b> .....	<b>5-86</b>
<b>Clearance Retract Angle</b> .....	<b>5-86</b>
<b>Dwell RPMS</b> .....	<b>5-86</b>
<b>Dwell Revolutions</b> .....	<b>5-86</b>
<b>RAD options/Ratio</b> .....	<b>5-86</b>
<b>Programming Horizontal Stops</b> .....	<b>5-87</b>
<b>Programming Bore Length</b> .....	<b>5-87</b>
<b>Deviation from main line</b> .....	<b>5-87</b>
<b>Graph Probed Values</b> .....	<b>5-87</b>
<b>Running the Auto Cycle</b> .....	<b>5-87</b>
<b>Thrust Cutting</b> .....	<b>5-88</b>
<b>Setting Zeros</b> .....	<b>5-88</b>
<b>Horizontal Zero</b> .....	<b>5-88</b>
<b>Dimensions &amp; Auto Cycle</b> .....	<b>5-89</b>
<b>Thrust Dimensions</b> .....	<b>5-89</b>
Outside.....	5-89
Inside.....	5-89
Cutter .....	5-89
<b>Clearances</b> .....	<b>5-89</b>
Vertical .....	5-89
Horizontal .....	5-89
<b>Dimensions</b> .....	<b>5-89</b>
Main Width.....	5-89
Insert Width .....	5-90
Left Depth of Cut.....	5-90

**Right Depth of Cut .....5-90**  
**Cut Right Side .....5-90**  
**Cut Left Side .....5-90**  
**Description and Running of the Auto Cycle ..... 5-90**  
**Start Auto Cycle .....5-90**  
**Backing Up and Restoring Block Profiles.....5-91**

## Operating Instructions

The purpose of this chapter is to explain and then guide the operator from loading a block through running an automatic cycle.

All modes of operation will be discussed in this chapter.

**Note:** *We recommend, particularly for operators unfamiliar with the boring machine, to practice on a junk block in order to become familiar with the controls and procedures of the boring machine.*

### Loading Blocks

#### Small Gas and Diesel

##### Manual V6/V8 Combination Fixture 502-1-72H



Handle the block and fixture with EXTREME care and guidance. A block hoist is REQUIRED. Mishandling of a heavy engine block and fixture may result in the dropping of parts and personal injury.

The Model 502-1-72H manual V6/V8 combination fixture is a fast, simple and universal system to properly and accurately hold most 60 degree V-type engine blocks for either cylinder boring or deck surfacing. See illustration on the following page.

#### Boring Application

**NOTE:** *The block must have the main bearing caps in place and torqued.*

Care must be taken to assure the contact edges of the locator bar are near the cap split line. A pair of 3/8" and 1/2" spacers are provided for blocks with large main bearing bores, to enable the bar to locate near the main bearing split line. (See figure 2)

**V-blocks:** (blocks with main bearing center lines no more than 1/2" higher than the pan rail plane) are mounted with the 502-3-8B V-block frame in place. Select the 90-degree option placement of the frame to suit block length, or main bearing caps will interfere with frame. Rotate frame 90 degrees by moving its shoulder screws to alternate set of holes.

**Y-Blocks:** (blocks with main bearing center lines 2-3/8" to 3-1/2" higher than the pan rail plane) are mounted directly on the fixture. Some Y-blocks (GM 60 degree) have too narrow pan rails and some have too low main bearing location which will require the use of the 502-1-15C precision 1-1/4" x 3" parallel set to raise and or support the block. Use the shoulder screw from the V-block frame and hook the parallels over the back of the V-fixture.

This fixture may be easily repositioned on the support parallels (without a block in place) to shift from the 60 degree support surface to the 90 degree support surface or vice versa.

**⚠ WARNING** Extreme care must be taken by operator whenever handling large blocks. Large blocks may cause fixture to tip when floated too far outward. We recommend leaving hoist attached when moving these blocks. Large blocks should be lifted from the block bank surface.

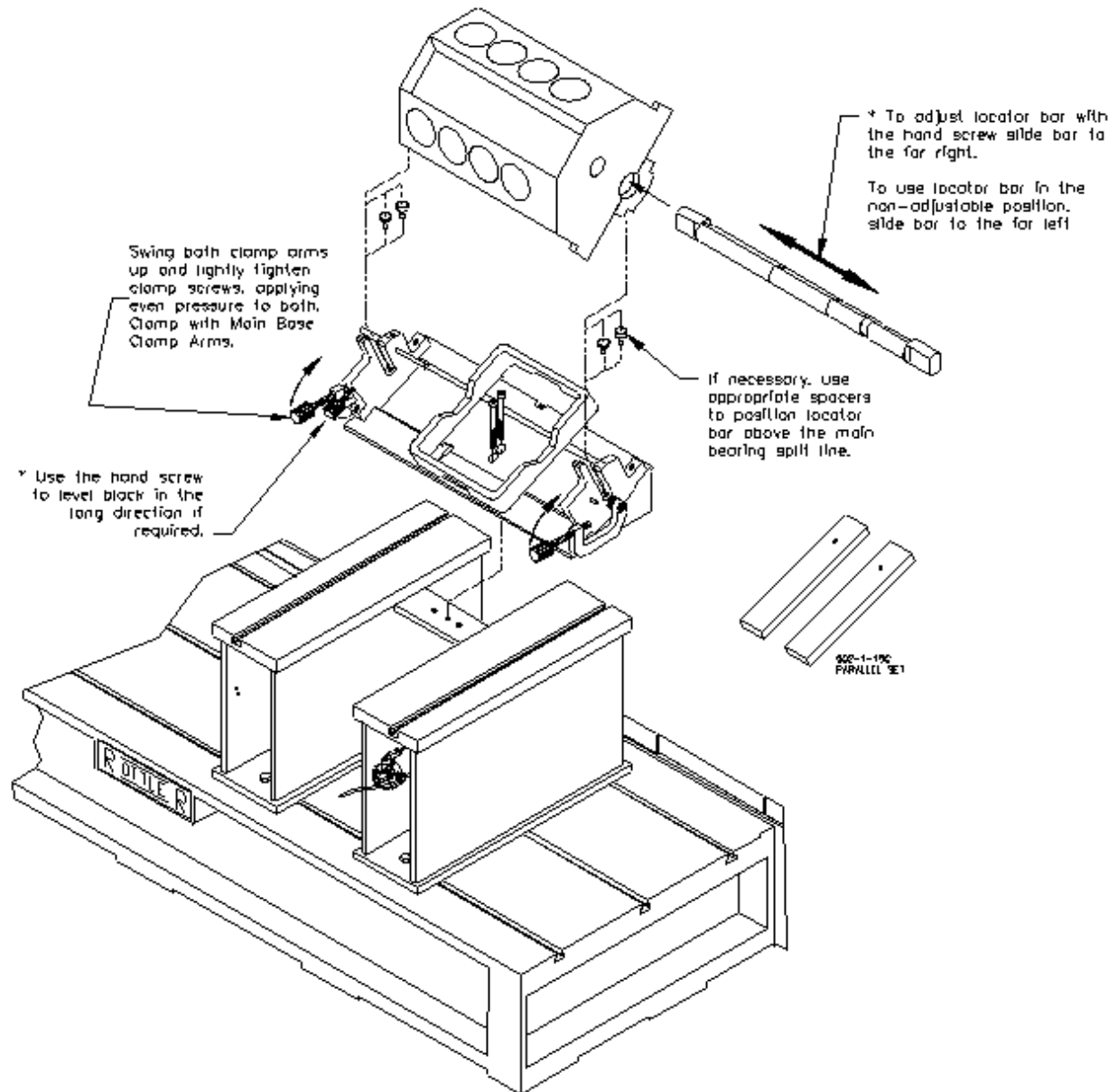

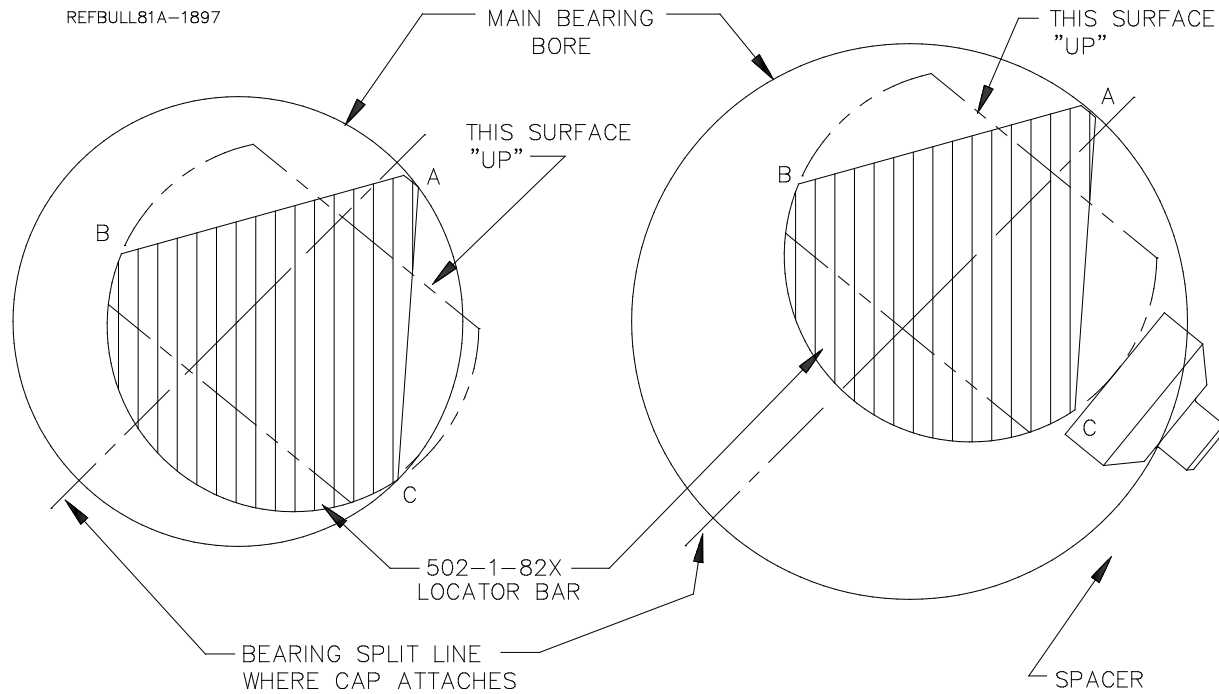

FIGURE 1

FIGURE 2

### Normal Operating Procedure

The normal operation procedure on smaller V-blocks is to first pick up the block. Place the 502-1-82X locator bar through the main bearings and hoist the block into the fixture. Pulling the block towards you, with the locator against the positioners, will prevent jamming in the slot of the guides during the loading and unloading operations. The locator bar is positioned with the word 'UP' that is on the end of the bar facing up and away from the operator. (see figure 1) After the locator bar is engaged in the positioners, pivot block outwards as you lower it. Slide block to the far left (this is the non adjustable position).

Make sure the block is firmly seated in place and not resting on pan-rail burrs or other interference points. Accurate seating can also be a problem with extremely warped, distorted blocks. Another cause of problems is failure to remove main bearing inserts. The locator bar has a relief for blocks with a small main bearing or seal. Rotate locator bar clamps into position & lightly tighten the hand screws, applying even pressure to both. Clamp the block securely with the main base clamp arms.

Warped or distorted blocks may require leveling of the deck surface in the long direction. This is possible with the hand-screw assembly in the left-hand bar positioner. Loosen both clamp hand-screws and slide the locator bar to the far right position. Retighten both clamp hand-screws. Raise or lower the adjusting hand-screw as required. For the non-adjustable position slide locator bar to the far left.

Push fixture back into bore position. There is a guide block (502-1-105) attached to the bottom of the fixture to aid in guiding the fixture along the support ways.

Operate the block clamp arms, bore, and pull fixture back to the load position.

Loosen locator bar hand screws and rotate clamps out of the way. Lift the block, either from the deck surface or with the optional 502-1-95 block handler. Turn the block 180 degrees & reload to duplicate the operation on the other bank.

After turning the engine block 180 degrees the locator bar must be twisted 180 degrees also. Again the word 'UP' must enter into the positioners facing up and away from the operator. (See figure 1).

**Figure 1**

502-1-82X main bearing locator bar indexes at point A. When bank is reversed and the bar is twisted 180 degrees, point A still indexes the main bearing.

Point C holds the block down. When bank is reversed and the bar is twisted 180 degrees, point B holds the block down.

**Figure 2**

502-1-82X main bearing locator bar indexes near bearing split line. Point C does not contact the bearing cap but rests on matched spacers that are provided to fit in the bar positioners slot. If there is a means of holding the block down such as block clamp towers, this method may be used in large bores in order to properly index near the bearing split line. If extreme care is used this method may be used to index blocks without bearing caps attached. (Optional clamp down must be provided).

## Surfacing Application

NOTE: The block must have the main bearing caps in place and torqued.

Care must be taken to assure the contact edges of the locator bar are near the cap split line. A pair of 3/8" and 1/2" spacers are provided for blocks with large main bearing bores, to enable the bar to locate near the main bearing split line. (See figure 2)

### V-blocks:

(blocks with main bearing center lines no more than 1/2" higher than the pan rail plane) are mounted with the 502-3-8B V-block frame in place. Select the 90-degree option placement of the frame to suit block length, or main bearing caps will interfere with frame. Rotate frame 90 degrees by moving its shoulder screws to alternate set of holes.

### Y-Blocks:

(blocks with main bearing center lines 2-3/8" to 3-1/2" higher than the pan rail plane) are mounted directly on the fixture. Some Y-blocks (GM 60 degree) have too narrow pan rails and some have too low main bearing location which will require the use of the 502-1-15C precision 1-1/4" x 3" parallel set to raise and or support the block. Use the shoulder screw from the V-block frame and hook the parallels over the back of the V-fixture.

This fixture may be easily repositioned on the support parallels (without a block in place) to shift from the 60 degree support surface to the 90 degree support surface or vice versa.



**⚠ WARNING** Extreme care must be taken by operator whenever handling large blocks. Large blocks may cause fixture to tip when floated too far outward. We recommend leaving hoist attached when moving these blocks. Large blocks should be lifted from the block bank surface.

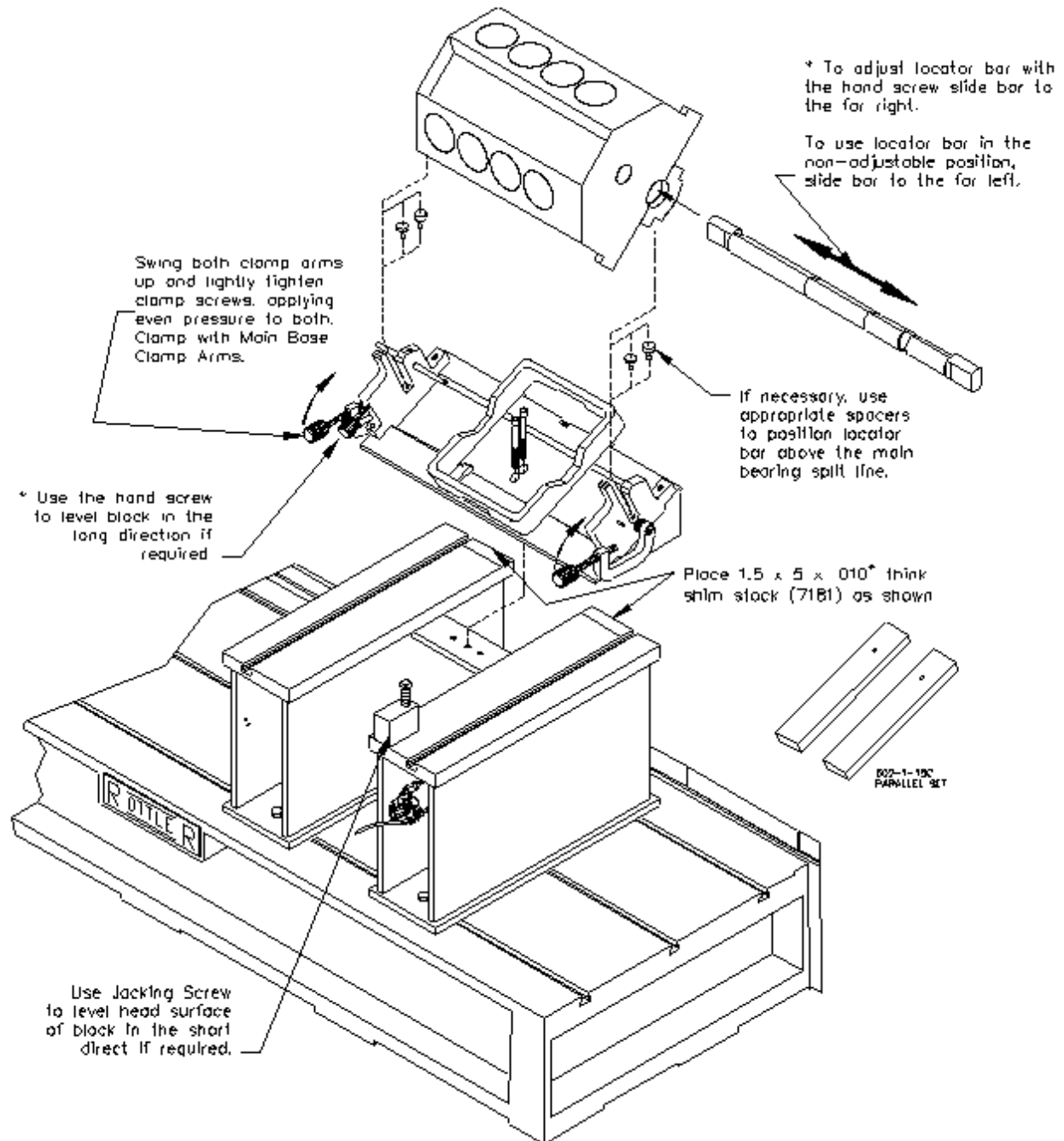

## Normal Operating Procedure

The normal operation procedure on smaller V-blocks is to first pick up the block. Place the 502-1-82X locator bar through the main bearings and hoist the block into the fixture. Pulling the block towards you, with the locator against the positioners, will prevent jamming in the slot of the guides during the loading and unloading operations. The locator bar is positioned with the word 'UP' that is on the end of the bar facing up and away from the operator. (see figure 1) After the locator bar is engaged in the positioners, pivot block outwards as you lower it. Slide block to the far left (this is the non adjustable position).

Make sure the block is firmly seated in place and not resting on pan-rail burrs or other interference points. Accurate seating can also be a problem with extremely warped, distorted blocks. Another cause of problems is failure to remove main bearing inserts. The locator bar has a relief for blocks with a small main bearing or seal. Rotate locator bar clamps into position & lightly tighten the hand screws, applying even pressure to both. Clamp the block securely with the main base clamp arms.

Warped or distorted blocks may require leveling of the deck surface in the long direction. This is possible with the hand-screw assembly in the left-hand bar positioner. Loosen both clamp hand-screws and slide the locator bar to the far right position. Retighten both clamp hand-screws. Raise or lower the adjusting hand-screw as required. For the non-adjustable position slide locator bar to the far left.

Push fixture back into surfacing position with the back of the fixture on the Shim Stock. The shim stock is put in place to raise the back side of the block, you can then use the Jacking Screw to raise and lower the front of the block. There is a guide block (502-1-105) attached to the bottom of the fixture to aid in guiding the fixture along the support ways.

Operate the block clamp arms, surface, and pull fixture back to the load position.

Loosen locator bar hand screws and rotate clamps out of the way. Lift the block, either from the deck surface. Turn the block 180 degrees & reload to duplicate the operation on the other bank.

After turning the engine block 180 degrees the locator bar must be twisted 180 degrees also. Again the word 'UP' must enter into the positioners facing up and away from the operator. (See figure 1).

### Figure 1

502-1-82X main bearing locator bar indexes at point A. When bank is reversed and the bar is twisted 180 degrees, point A still indexes the main bearing.

Point C holds the block down. When bank is reversed and the bar is twisted 180 degrees, point B holds the block down.

### Figure 2

502-1-82X main bearing locator bar indexes near bearing split line. Point C does not contact the bearing cap but rests on matched spacers that are provided to fit in the bar positioners slot. If there is a means of holding the block down such as block clamp towers, this method may be used in large bores in order to properly index near the bearing split line. If extreme care is used this method may be used to index blocks without bearing caps attached. (Optional clamp down must be provided).

### Retrofitting 502-1-15C Parallels to V6/V8 Combination Fixture

(Special Applications)

Some engine blocks with large main bores (3-1/8" and larger) cause a problem of the locator bar bottoming out in the bar positioners and/or the V-shaped relief's of the 502-3-8B V-block frame before clamping the block properly. Mounting the 502-1-15C parallel set as shown below in place of the V-block frame will provide proper clearance for clamping. Older style fixtures and parallels can be modified to this configuration using illustrations below.

V-6 blocks with one-piece 'caged' main bearing caps (all caps are connected) can interfere with 502-3-8B V-block frame. The parallel arrangement shown below will allow proper support and clamping of these blocks.

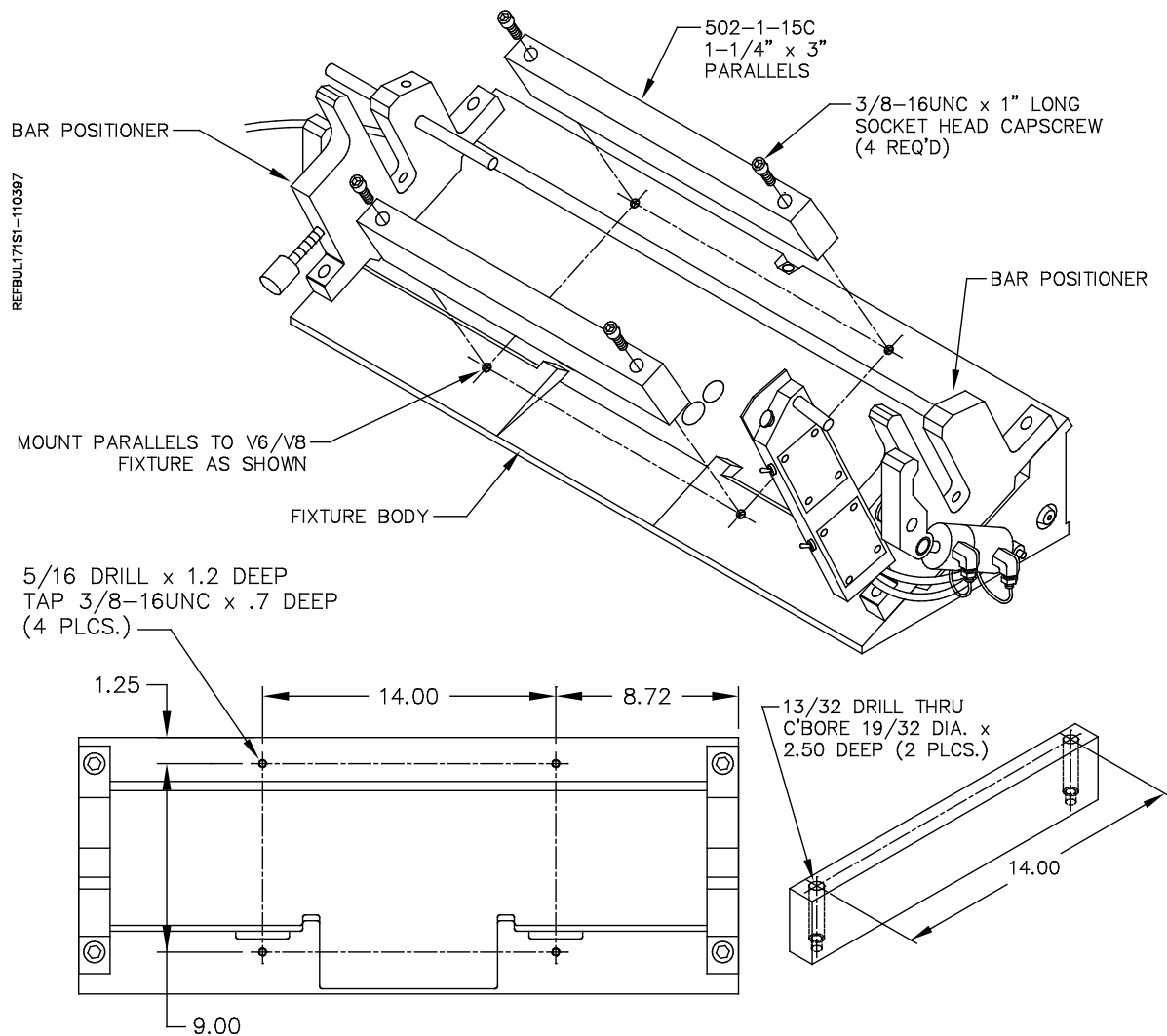

Some V-6 engine blocks (for example Buick V-6) have main bearing bores that are too low in respect to the pan rails. This presents a problem of the locator bar bottoming out in the bar positioners before the block is properly clamped. Positioning the 502-1-15C parallel set as shown below will raise the block enough to provide proper clamping.

REFBUL171S2-110397

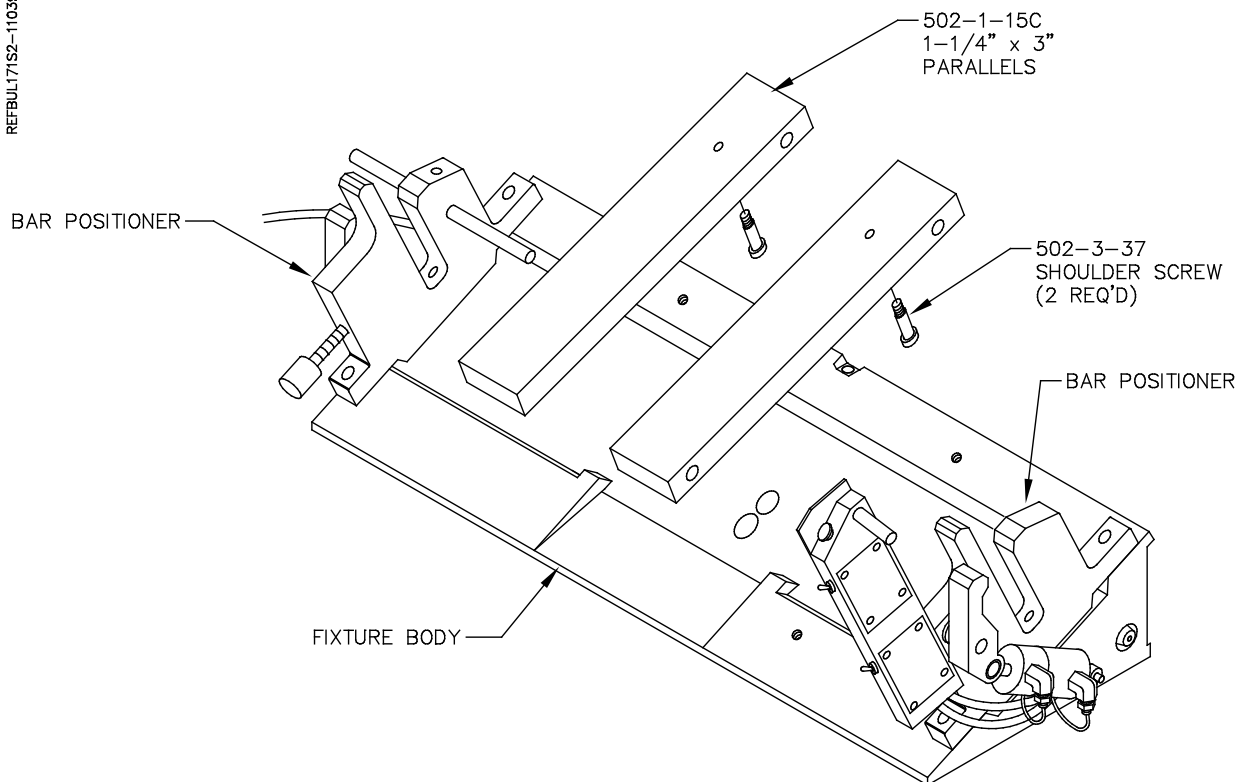

## Diesel Blocks

### 6725 Diesel Fixture

#### Small Diesel V Blocks

On these blocks it will be necessary to install the 6370Z, 10" parallels or 6794E, 8" parallels onto the bed of the machine. These parallels are keyed, place them onto the deck surface and then push them toward the rear of the machine. This will locate them evenly on the middle keyway of the machine bed. Place the two 6553F main bearing supports onto the parallels, these are also keyed and fit into the machined slots on the parallels. This will put the two main bearing supports in line with each other. Tighten all bolts to lock the parallels and main bearing support into place. Select the correct size main bearing locators and install them into the mains of the block..

**Note:** *Make sure there are no burrs or debris in the main bearing bores where they will contact the main bearing locators. This can cause the block not to clamp properly and may cause tipping or rocking of the block.*

Handle these large blocks with Extreme care and guidance. A block hoist is required when handling these blocks. These blocks should be lifted from the block bank surface.

 **WARNING** Install the main bearing locators into the mains of the engine block. Lower the block so that the locators go into the main bearing support.

The hoist must remain attached to the block until it is firmly clamped into position. The blocks will have a tendency to tip forward until they are properly supported and clamp. When not properly supported and attached to a hoist these blocks will roll forward and out of the fixture. This will cause severe injury or death to operator.

 **DANGER** Select the correct jacking screw to reach the block. Place the jacking screws into the jack bodies and place on the parallels in a location they will support the block from rolling forward. Position the block clamps so the front of the shoe will clamp the block in the middle on both ends. The following illustration shows the correct triangle clamping system that should be used. You can raise and lower the ends of the block by rotating the Hex nut located on the ends of the main bearing locators.

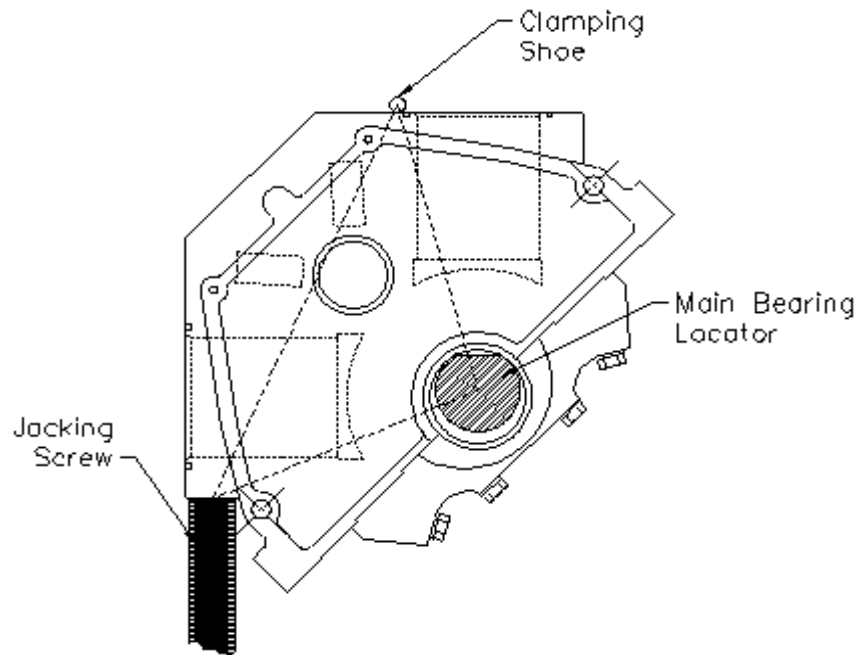
**Triangle Clamping**

Adjust the height so the shoes rest on the clamp points. Tighten the clamp leg handles. Actuate the clamp shoes by turning their knobs. Apply pressure to the two clamps as evenly as possible to avoid tipping the block up on one side.

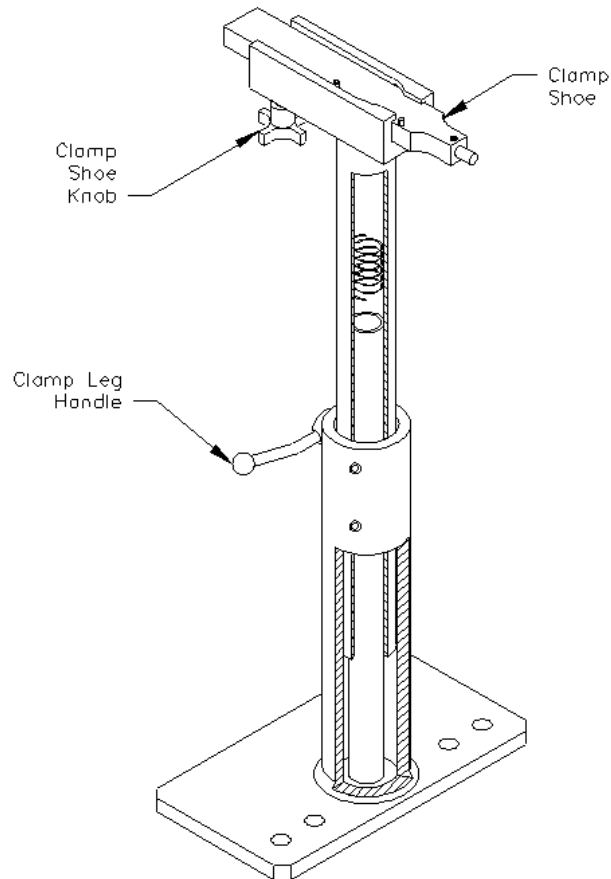
**Block Clamp Arm**

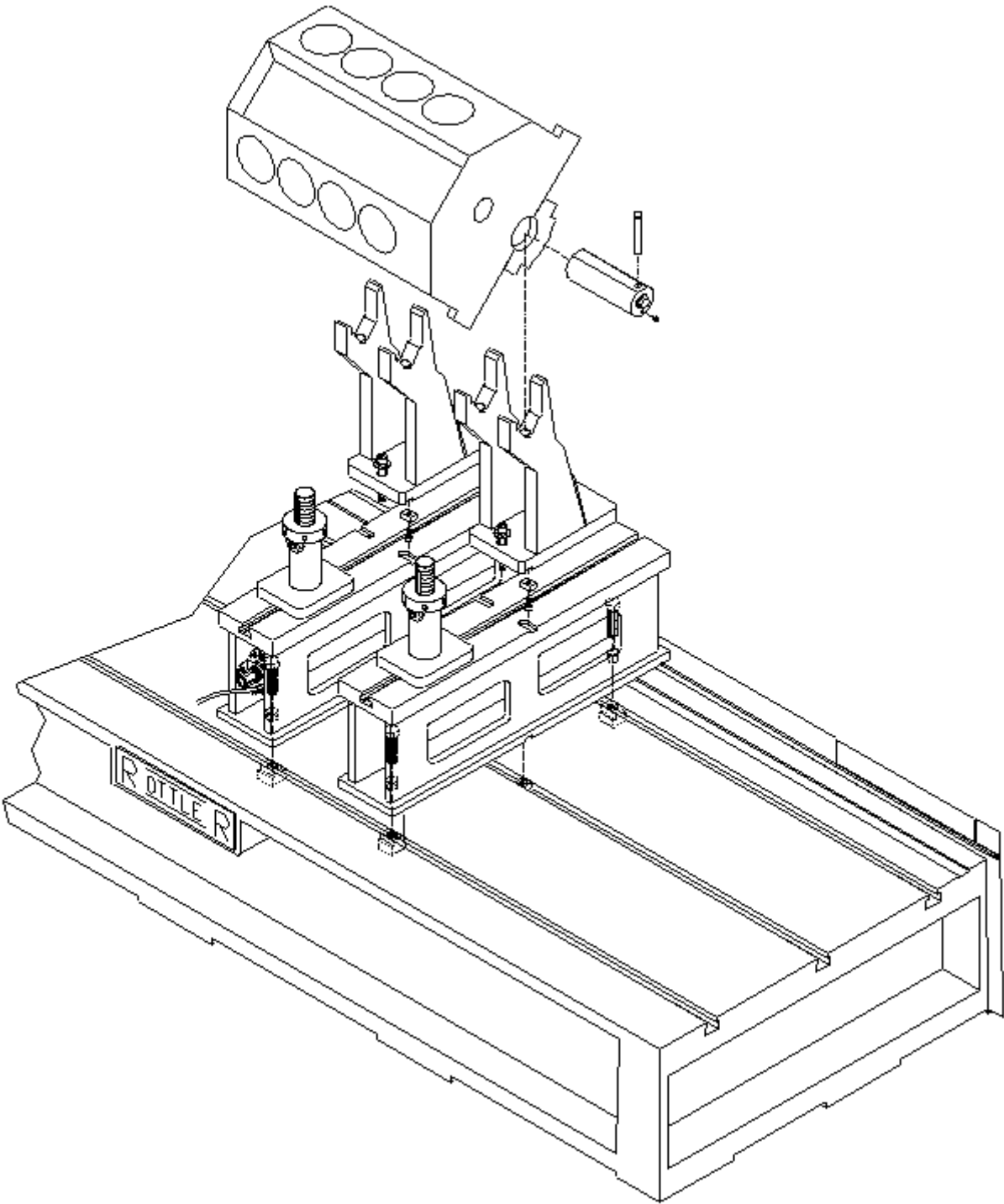

### Small Diesel In Line Blocks

On these blocks it will be necessary to install the 6370Z, 10" parallels onto the bed of the machine. These parallels are keyed, place them onto the deck surface and then push them toward the rear of the machine. This will locate them evenly on the middle keyway of the machine bed. Place the two 6553F main bearing supports onto the parallels, these are also keyed and fit into the machined slots on the parallels. Use the forward machined slots. This will put the two main bearing supports in line with each other, and on centerline of the machine bed.

Position the fixtures at a distance apart equal to the outboard main journals. Tighten all bolts to lock the parallels and main bearing support into place. Select the correct size main bearing locators, and install them into the mains of the block. Notice the locators have a flat area. Installing with the flat side up will allow end to end height adjustment of the block by rotating the locator. Installing with the round side up will position the block so all machining operations are parallel and perpendicular to the main bore centerline. This simply requires leveling the block in the front to rear direction.

**Note: Make sure there are no burrs or debris in the main bearing bores where they will contact the main bearing locators. This can cause the block not to clamp properly and may cause tipping or rocking of the block.**

#### **WARNING**

Handle these large blocks with Extreme care and guidance. A block hoist is required when handling these blocks. These blocks should be lifted from the block bank surface.

Lower the block so that the locators go into the main bearing support. A clevis pin is provided to keep the locator in position on the main bearing support.

For in-line blocks, load the block with the heavier side towards the front.

#### **DANGER**

The hoist must remain attached to the block until it is firmly clamped into position. The blocks will have a tendency to tip until they are properly supported and clamp. When not properly supported and attached to a hoist these blocks will roll forward or backwards and out of the fixture. This will cause severe injury or death to operator.

Select the correct jacking screws to reach the block. Place the jacking screws into the jack bodies and place on the machine bed in a location they will support the block from rolling forwards. Rough level the block using a spirit level.

The following illustration shows the correct triangle clamping system that should be used.

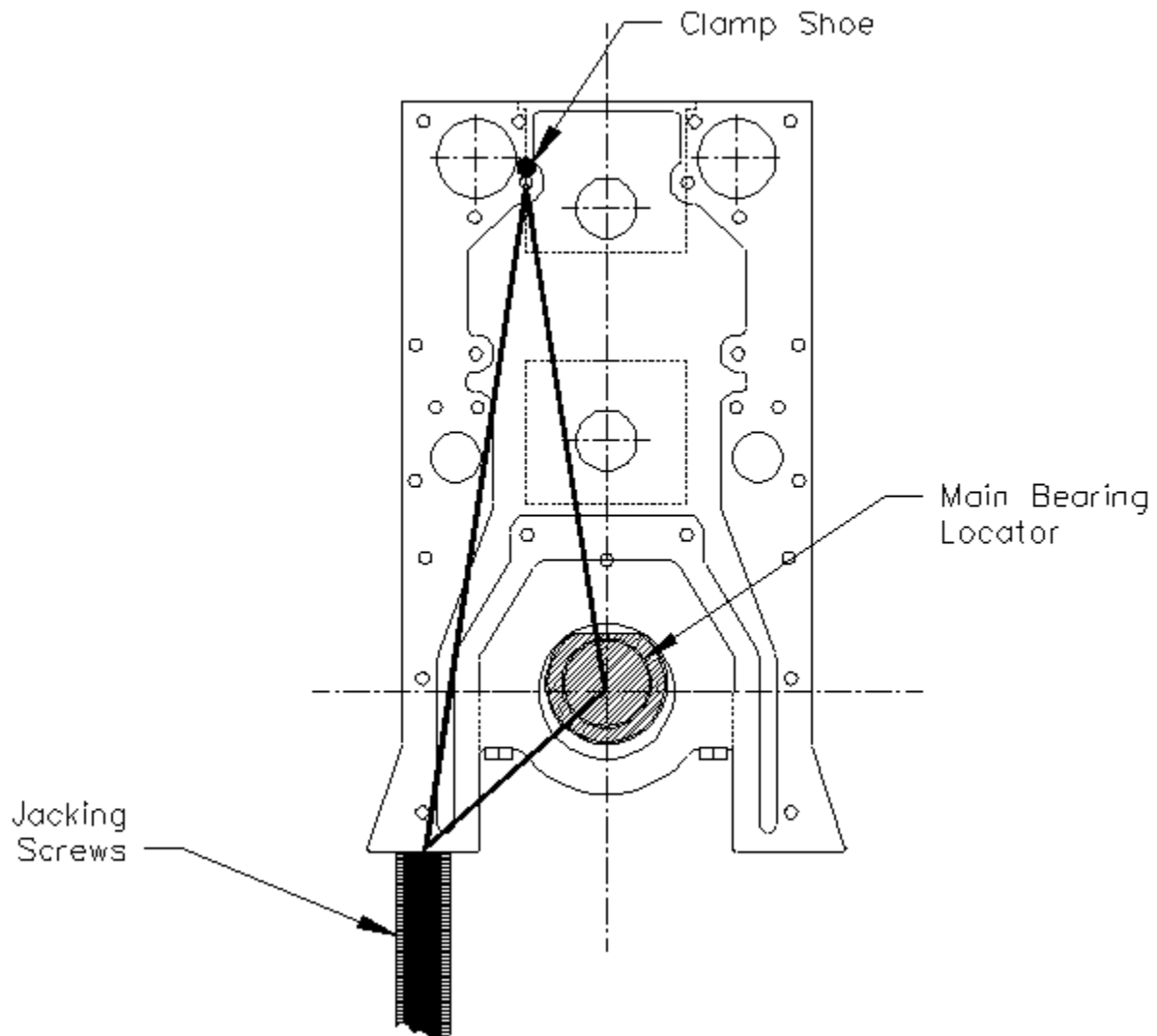

**Triangle Clamping**

Adjust the height so the shoes rest on the clamp points. Tighten the clamp leg handles. Actuate the clamp shoes by turning their knobs. Apply pressure to the two clamps as evenly as possible to avoid tipping the block up on one side.

Be sure the clamp is below the deck surface if you to resurface the block.

Do not release the hoist or lifting device from the block until the clamping is secure.



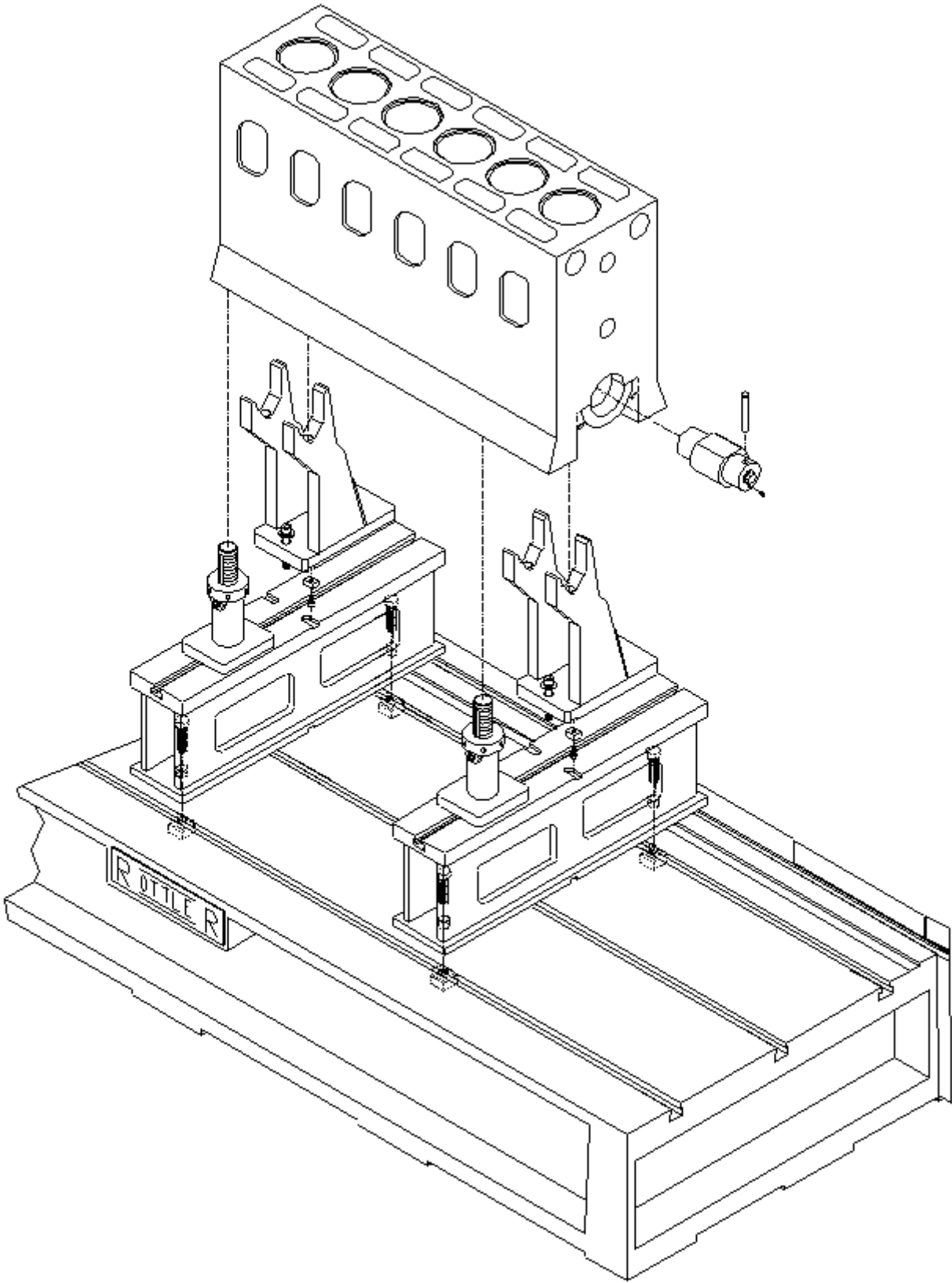

## 6405F Large V-Block

Place the 6405 supports on the machine bed. Make sure there is no debris or burrs on the mating surfaced. The supports should be placed on the machine bed with the two dowels on the bottom of the supports into the middle keyway. Place the supports the same distance apart as the mains you will be using. On long blocks, it is recommended to use main bearing locations inward from the ends, to more equally balance the block and avoid sag. Push the supports back toward the rear of the machine against the dowel pins. This will line the supports up with each other. Tighten the four (4) mounting bolts on each support.

Install the correct size locators into the main bores that will be used.



Handle these large blocks with Extreme care and guidance. A block hoist is required when handling these blocks. These blocks should be lifted from the block bank surface.

The hoist must remain attached to the block until it is firmly clamped into position. The blocks will have a tendency to tip until they are properly supported and clamp. When not properly supported and attached to a hoist these blocks will roll forward or backwards and out of the fixture. This will cause severe injury



or death to operator.

The main bearing bores being used, should be on centerline of each support. Set the jacking bodies, with the proper length jack screw installed onto the machine base. These should be located in the general area of the supports. Temporarily secure to the deck with at least one bolt.

Lower the block down onto the supports. Place a level on the deck of the engine block and check the level front to back. Position the jack stands in a location to properly support the block and secure. To level, use the jacking screws to raise or lower the front of the engine block.

Position the block clamps on the machine bed and secure in a location to allow proper clamping.

The following illustration shows the correct triangle clamping system that should be used.

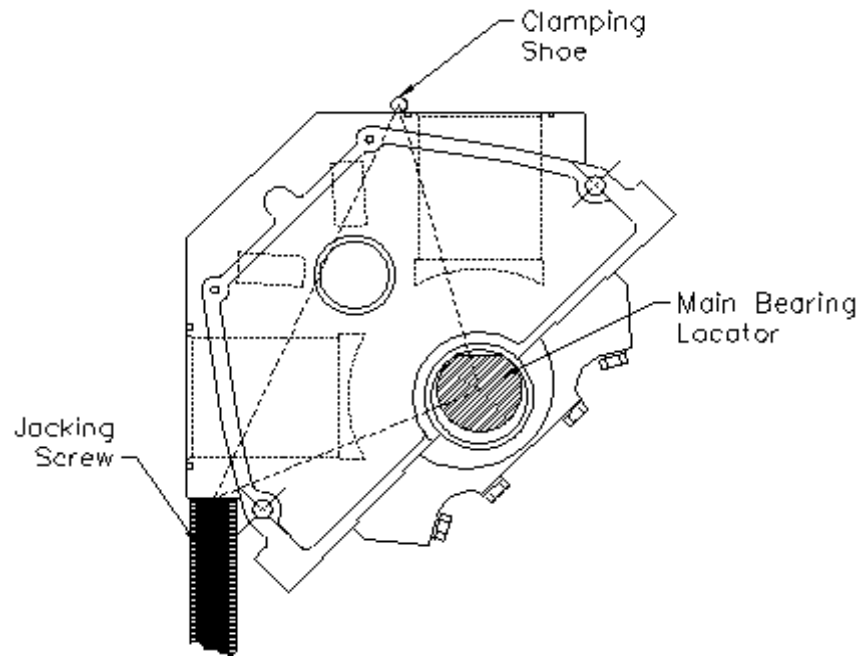
**Triangle Clamping**

Adjust the height so the shoes rest on the clamp points. Tighten the clamp leg handles. Actuate the clamp shoes by turning their knobs. Apply pressure to the two clamps as evenly as possible to avoid tipping the block up on one side.

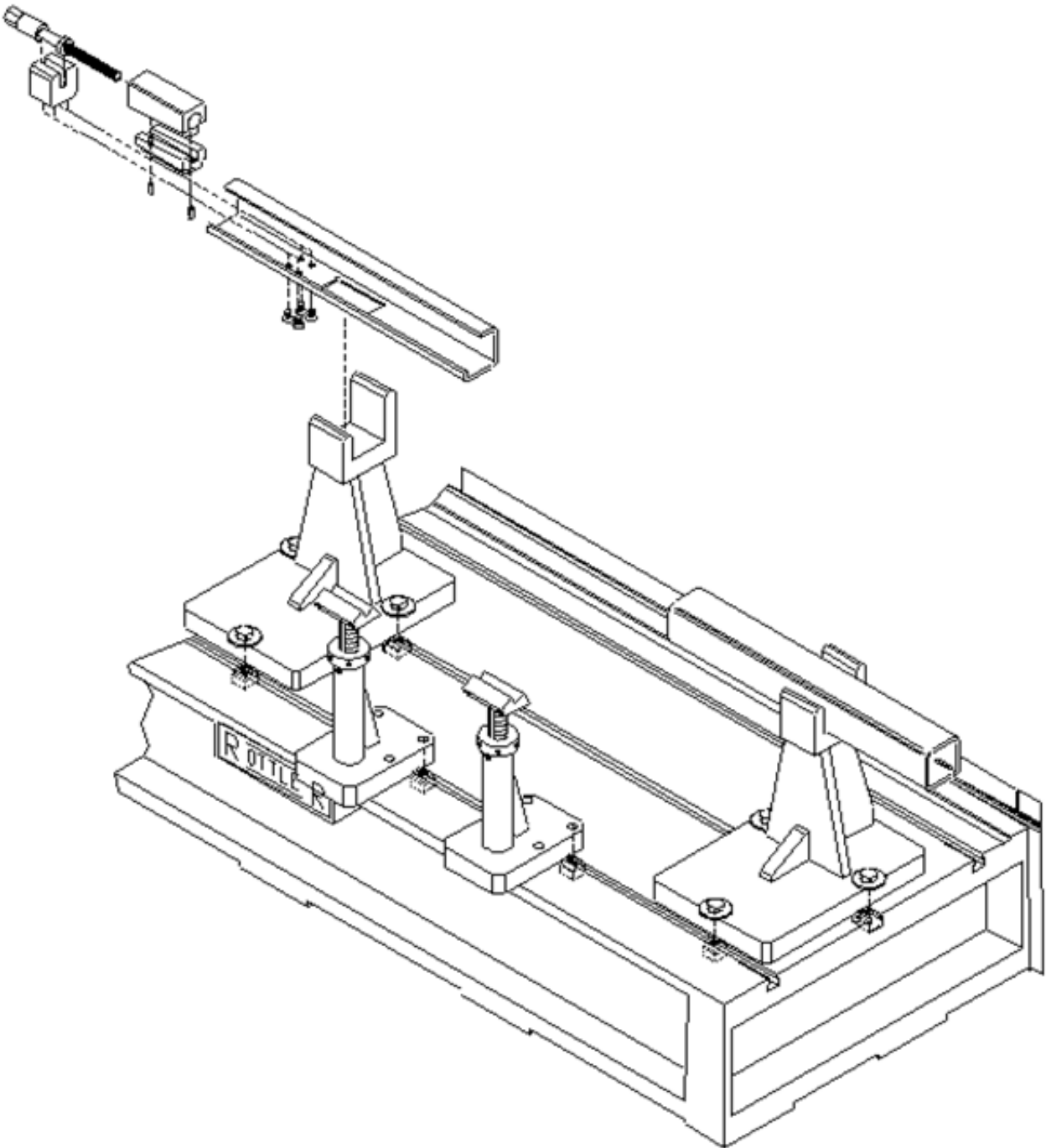

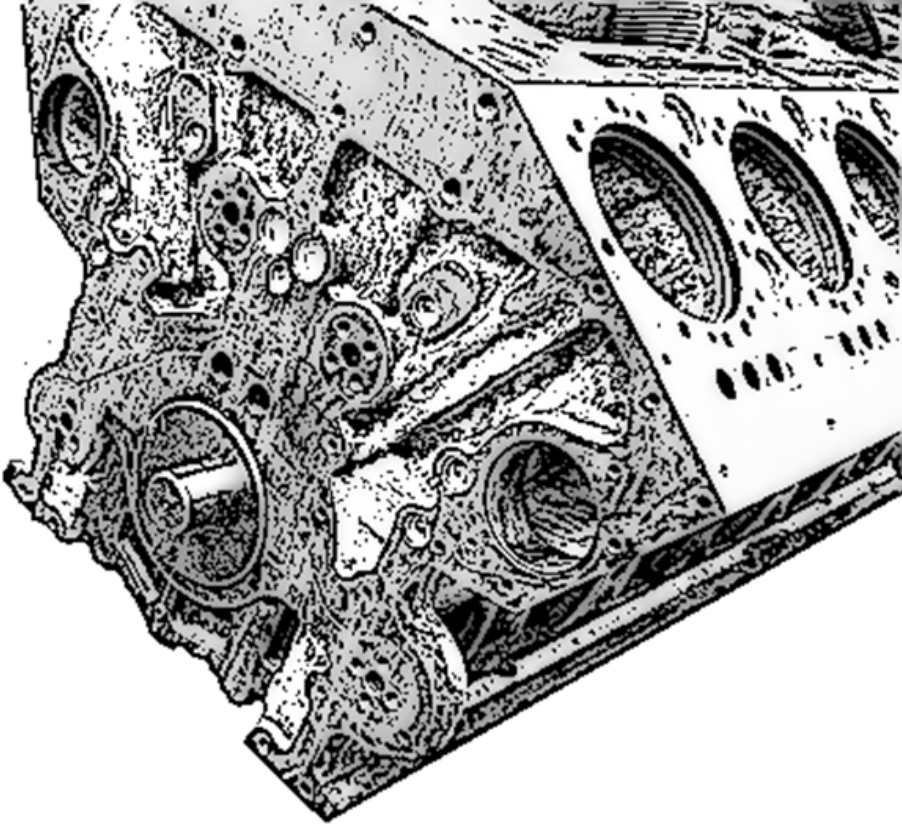

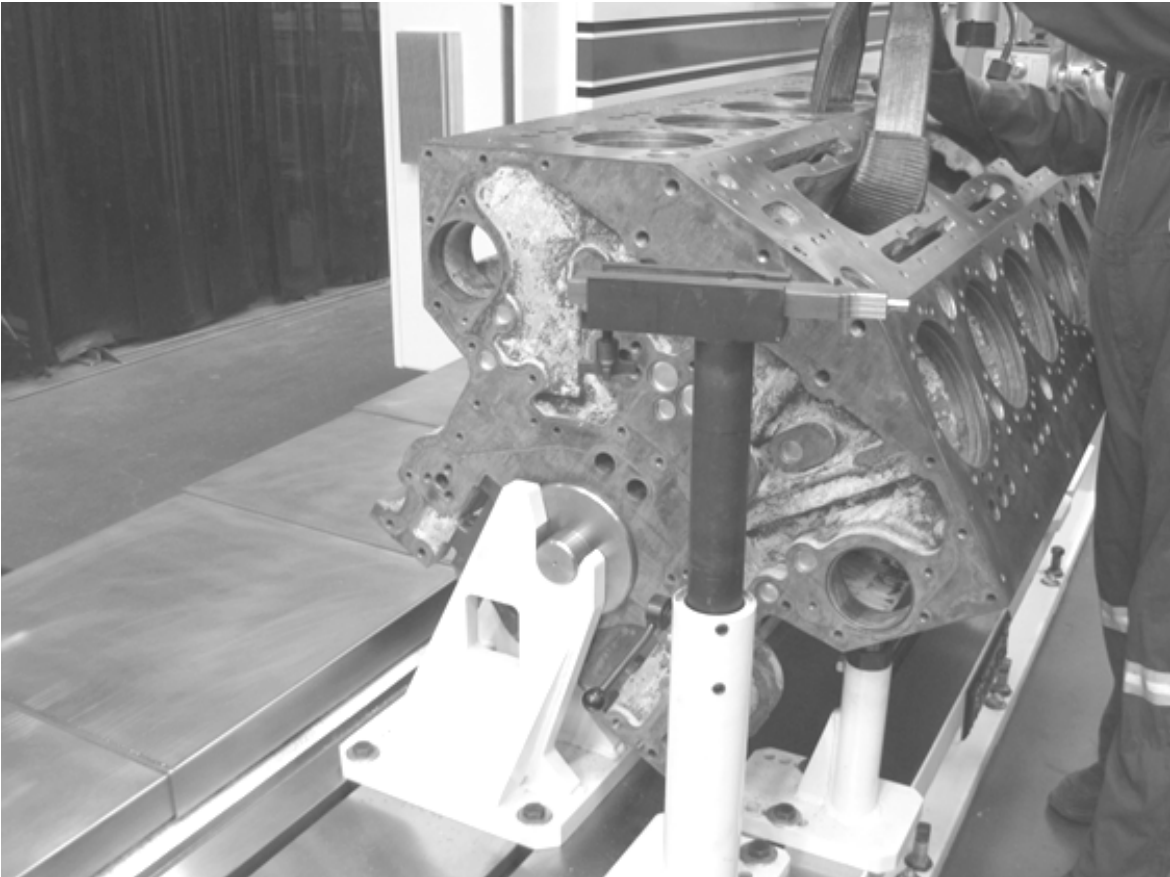
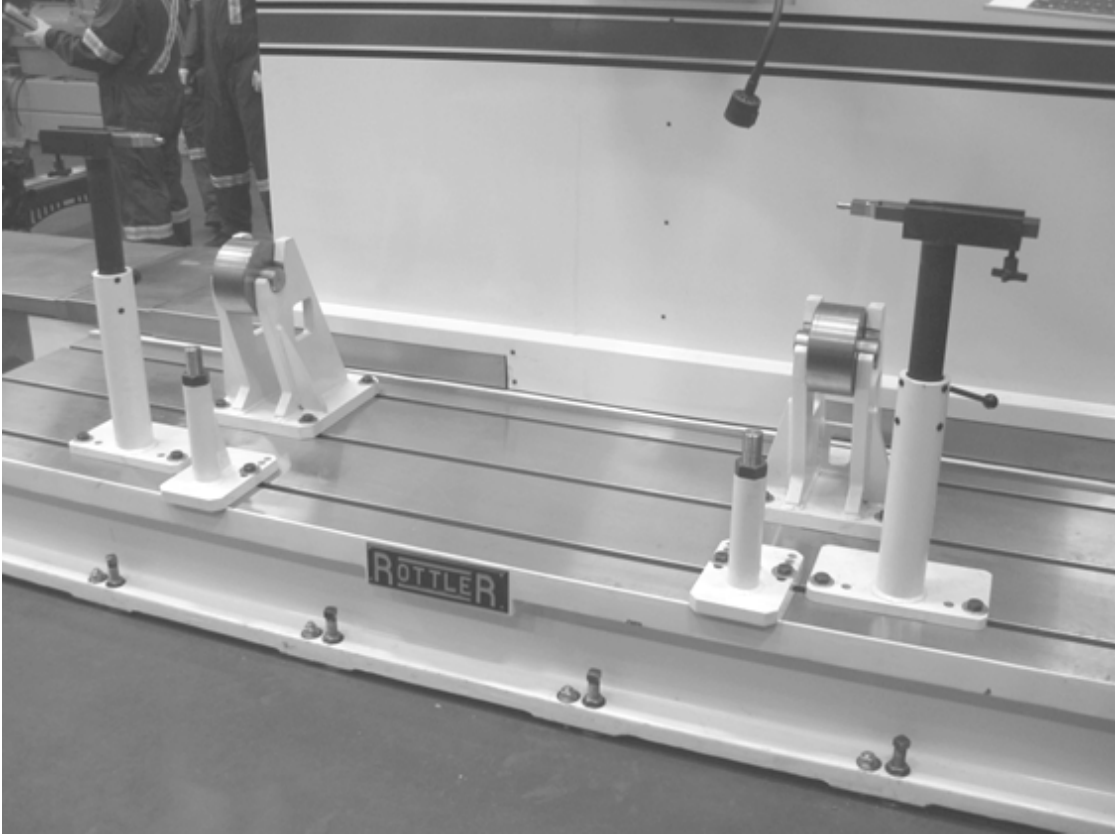



**6810 Waukesha 7042, 9390 and CAT 379, 398, 399 Block Line Bore Fixture**

This fixture is designed to be mounted directly on the bed of an F100 Series machine. Due to the large size of the Waukesha 7042 block, care must be taken when loading and unloading to avoid bumping the block into the column or spindle unit.

**WARNING** Handle these large blocks with Extreme care and guidance. A block hoist is required when handling these blocks.

Use the diagram on the following pages when referring to part numbers listed below. This Line Bore fixture consists of a stationary cradle and an adjustable support. The Cradle (6811A) is mounted to the machine bed over the locating pivot key and pin assembly. The locating pivot pin (6819) is pressed into the locating pivot key (6820). This assembly is positioned in the center keyway of the machine bed and the (2) set screws (MF-72) are tightened to lock the key in place. The Cradle is positioned over the pin and mounted to the machine bed. With the mounting bolts installed but not tight this provides a standard pivot point for the Cradle.

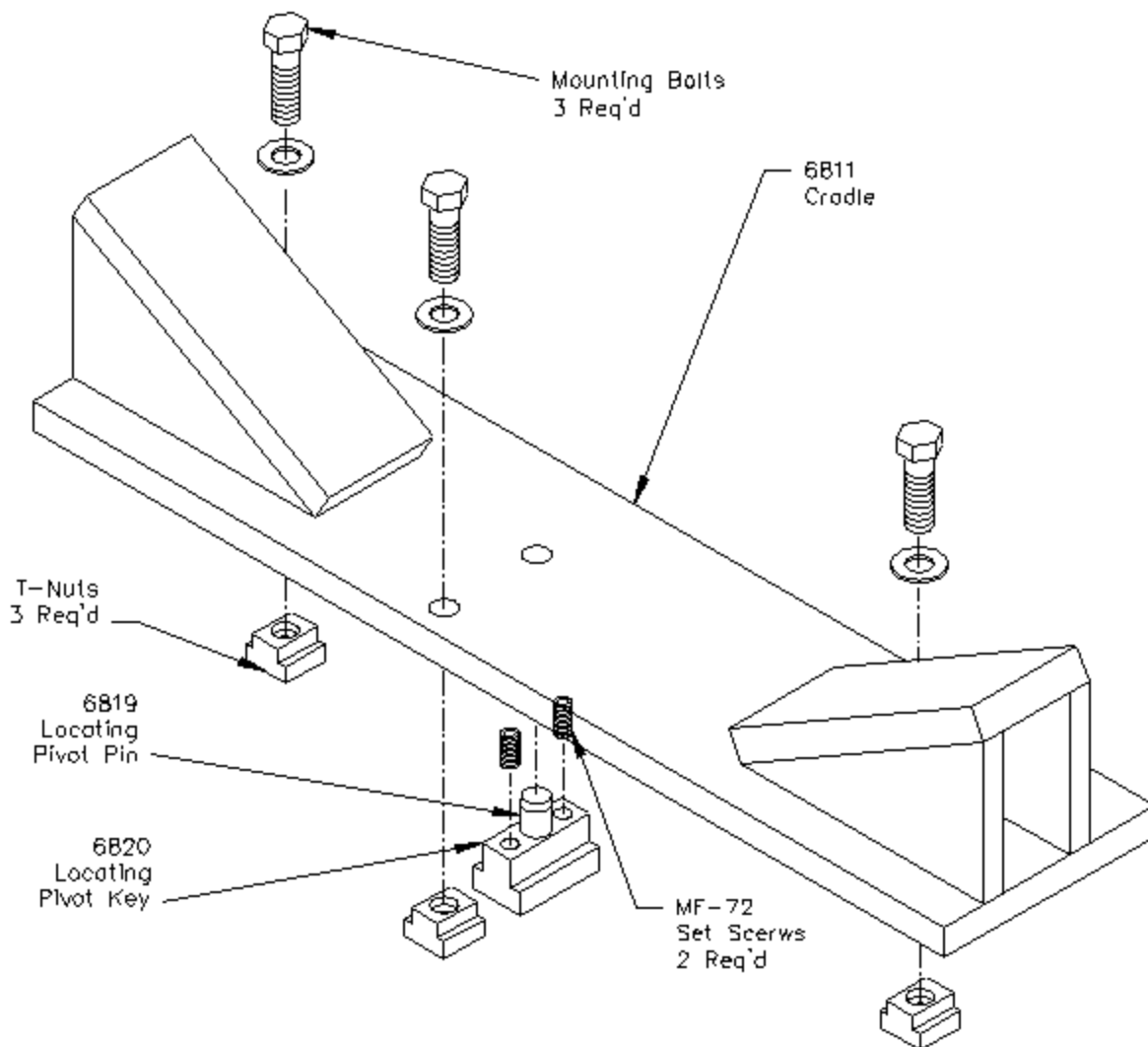



The support (6812A) is assembled with the adjusting screw (6754V) and the adjusting block (6814). This assembly is mounted to the machine bed with the lower tab of the adjusting block in the center keyway. **Be sure to install the special ratchet adjusting wrench prior to setting this assembly on the machine bed**

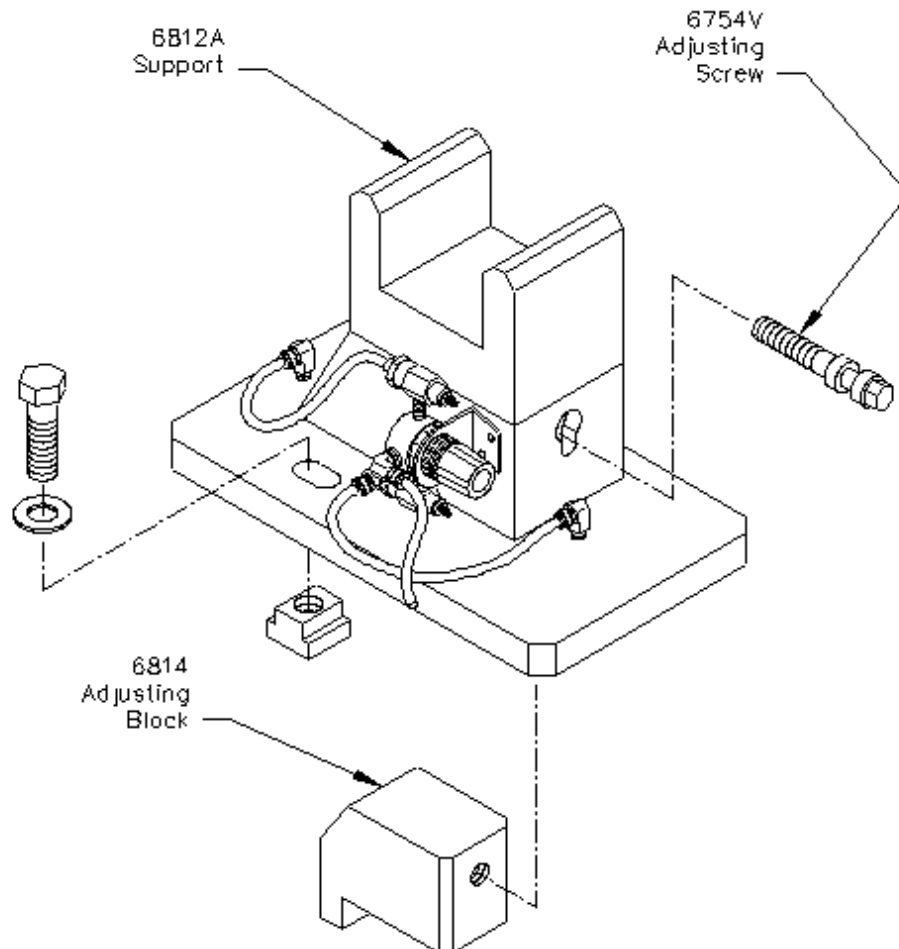

The adjustable tube (6813) is bolted to the Waukesha Block using the Cam Bearing Cap mounting holes. The adjustable tube has ten (10) holes drilled in it. Four (4) of the holes are used to bolt the adjustable tube to the engine block, the remaining six (6) holes are clearance for the cap alignment dowel pins in the engine block. Since the Cam Bearing Caps are not evenly spaced along the block, the adjustable tube must be mounted on the front end of the block as shown in the following illustration.

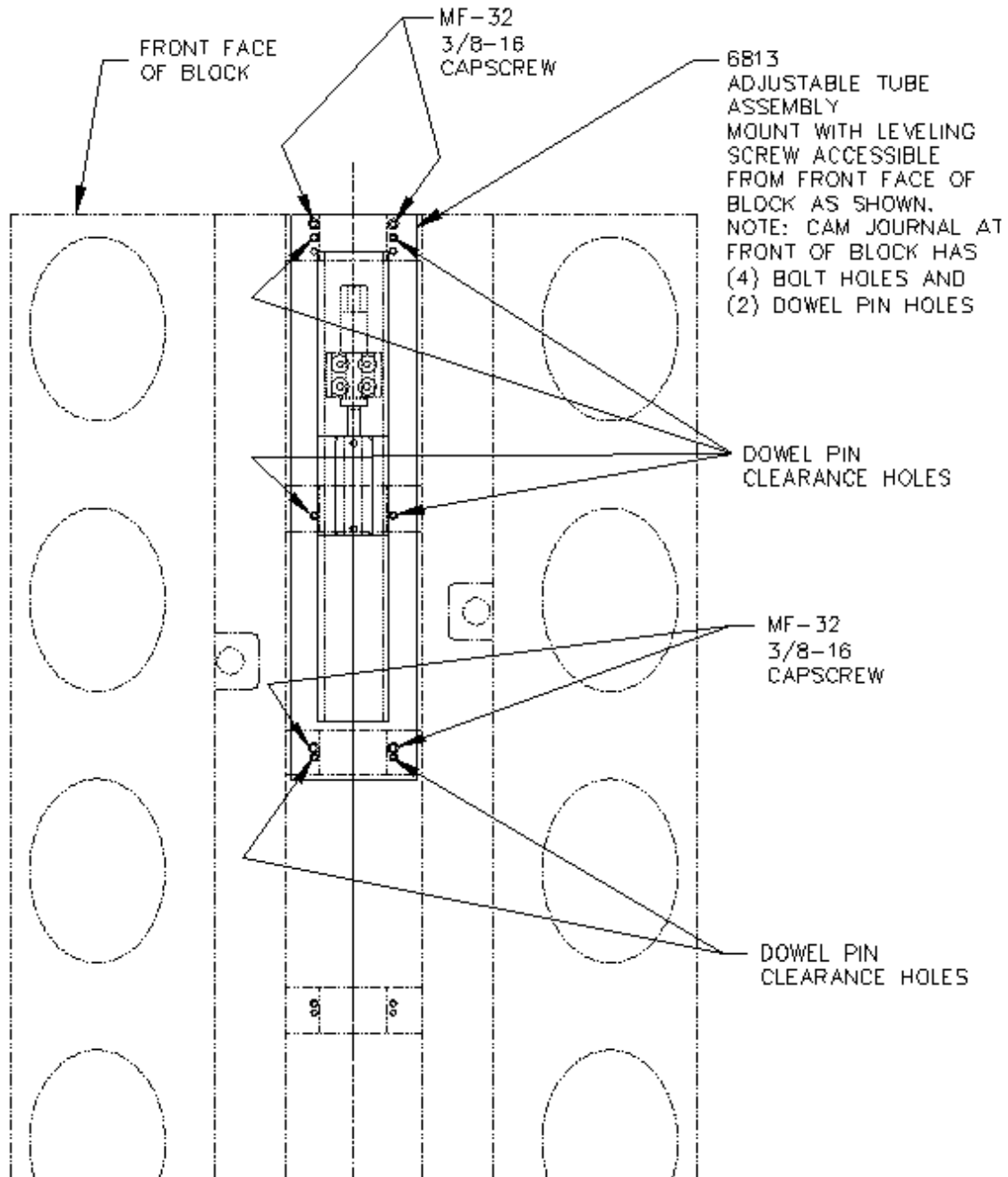

The upper and lower leveling pads, bracket and screw are already installed in the adjustable tube.

With the adjustable tube installed, the block is ready to be lowered into the Cradle and Support. Use caution to locate the adjustable tube correctly on the support. The two roll pins (MF-229B) installed in the lower leveling pad (6411) are designed to locate the leveling pads properly.

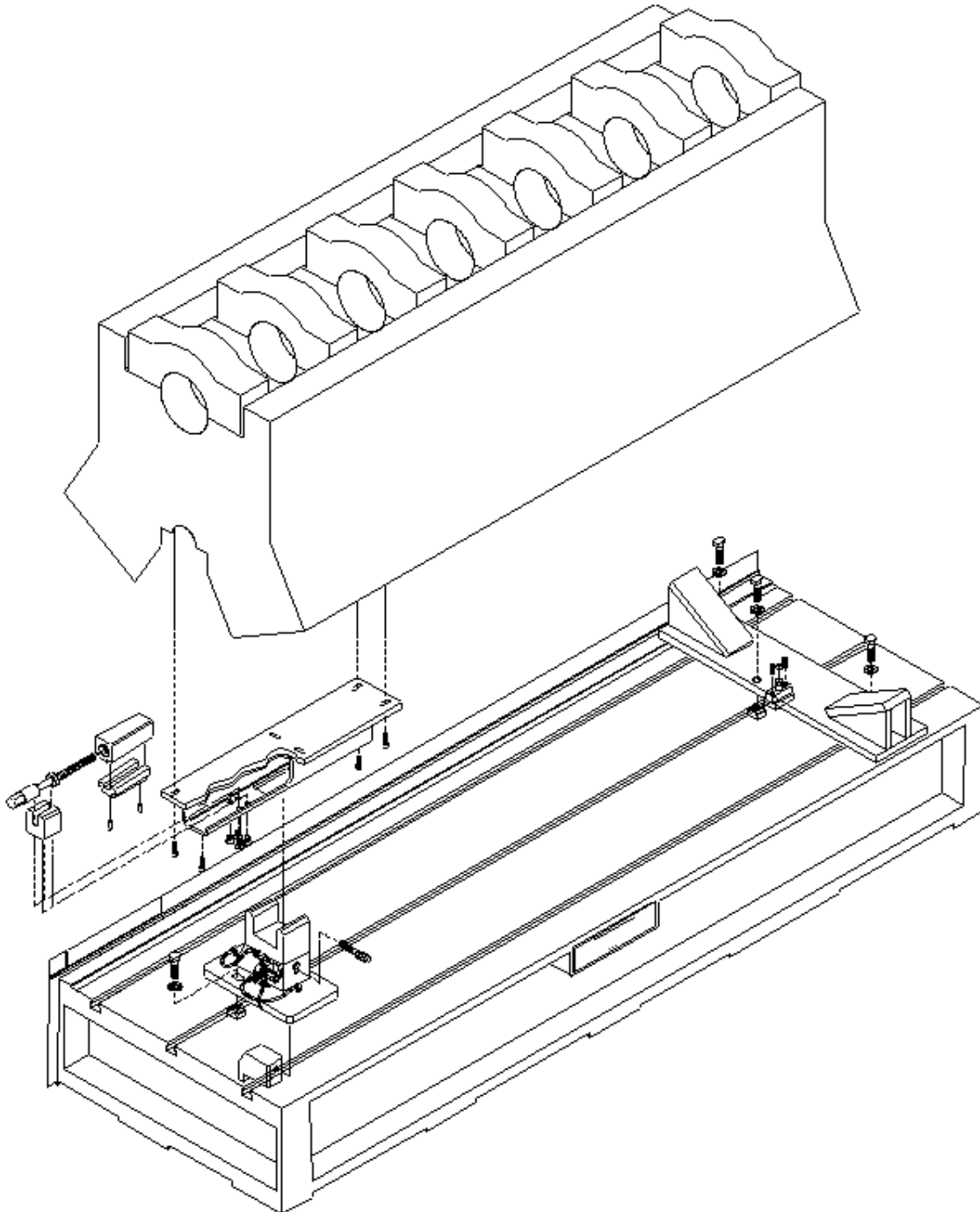

All mounting bolts should be loose to start with. Due to the design of this fixture the Cradle end of the block is stationary both in relationship to the machine bed key way and in height. This end is not adjustable. The adjustable end of the fixture is located on the same machine bed keyway as the cradle. Once the block is loaded into the fixture it is ready to be aligned for the line boring operation. Up and down adjustment is accomplished using the leveling screw (6408) inside the adjustable tube. The block is adjusted in and out by activating the air float on the support, and turning the adjustment screw using the previously installed ratchet wrench. Once the block is located in and out deactivate the air float and tighten the support end mounting bolt to lock into place. Tighten the three (3) mounting bolts on the Cradle end of the fixture now. The alignment of the block should be checked again at this time. Repeat alignment adjustments as needed.

## 6821 Adjustable, Universal Line Bore Parallel Assembly

This fixture is designed to be mounted directly on the bed of the F90 series machine. Due to the large size of these blocks, care must be taken when loading and unloading to avoid bumping the block into the column or spindle unit.

Handle these large blocks with Extreme care and guidance. A block hoist is required when handling these blocks.

### **⚠ WARNING**

Use diagrams on the following pages when referring to part numbers listed below. This Line Bore fixture consists of a stationary parallel and an adjustable parallel used in conjunction with a cradle that fits the block to be machined.

Install the 6820 Pivot Key (with Pivot Pin already pressed in) into the center keyway on the right hand side of the F90 bed. Tighten the two MF-72 set screws down. This will hold the Pivot key in place while the parallel pivots on the Pivot Pin (6819). Place the parallel onto the pivot pin, install the mounting bolts and washers but do not tighten down.

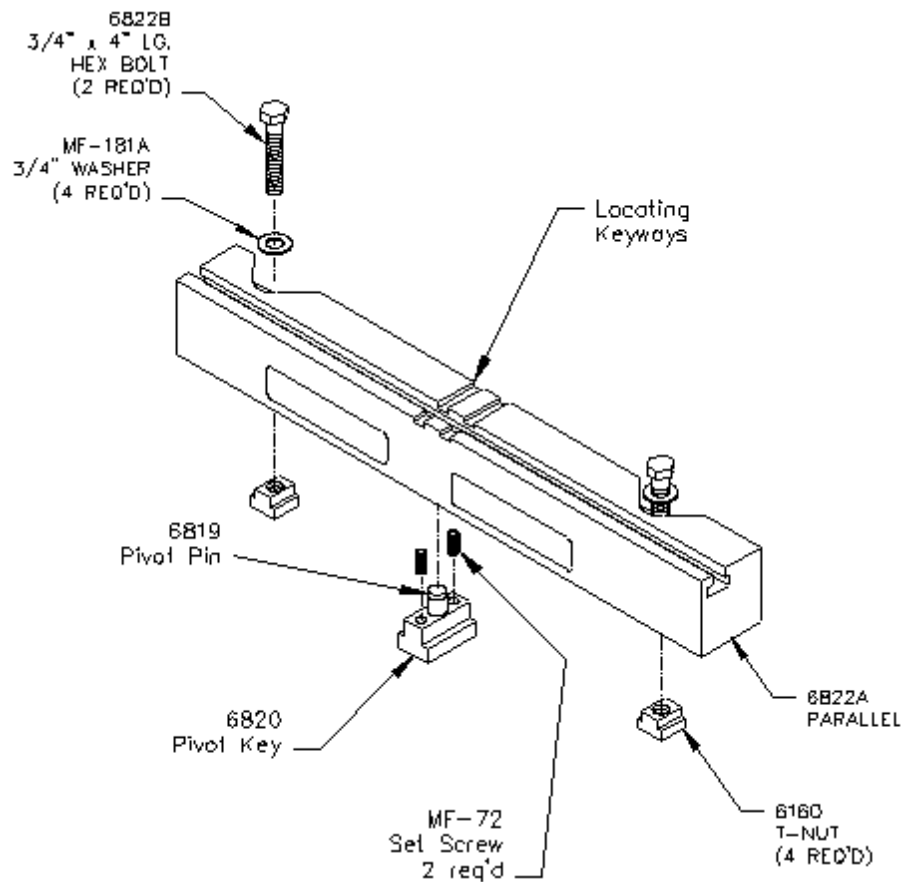

Install the adjustable parallel onto the left hand side of the F90 machine bed with the In/Out adjusting block (6830) located in the front keyway. Install the mounting bolts and washers but do not tighten down.

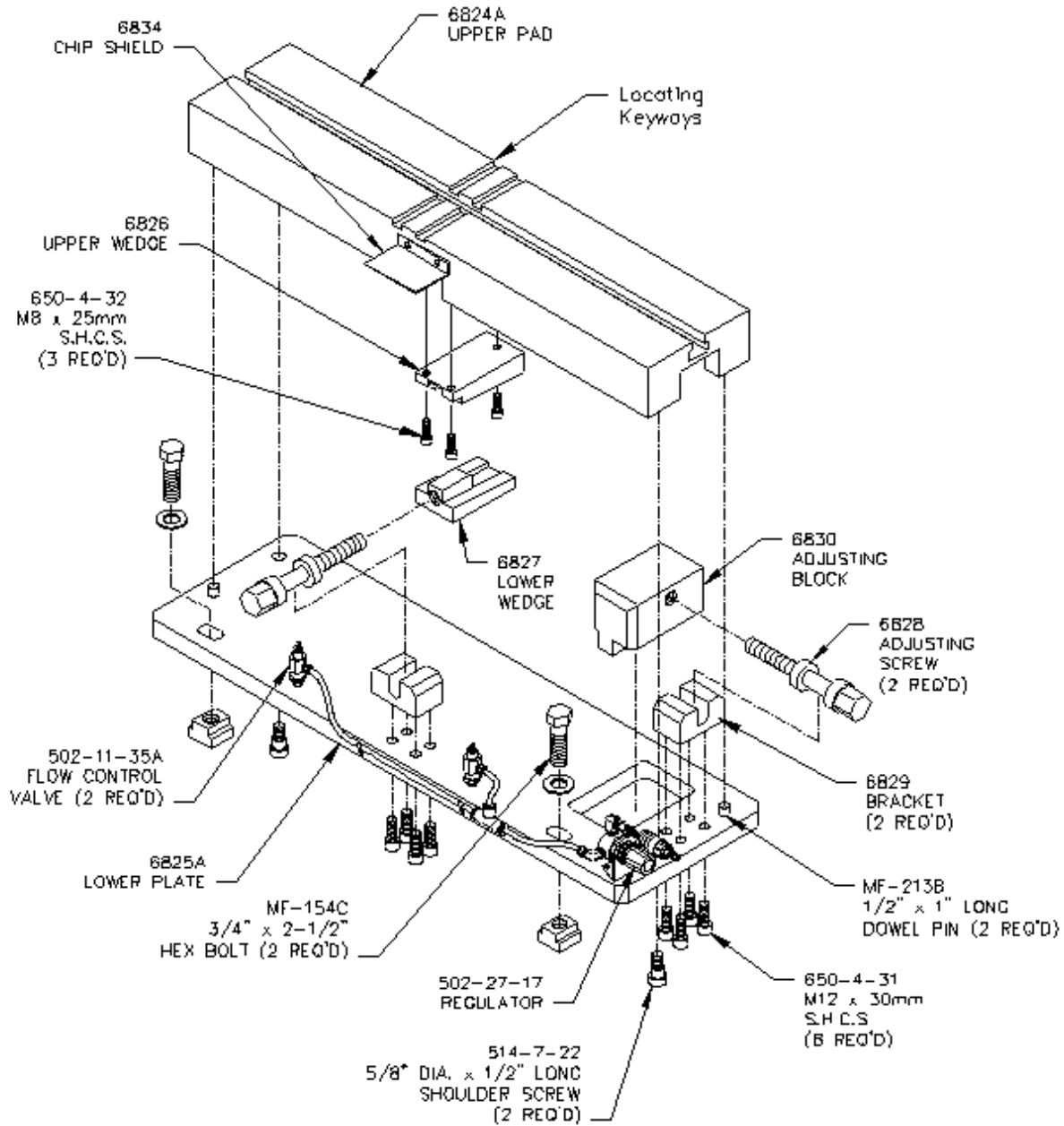

Once both parallels are installed on the machine bed, place a magnetic indicator on the spindle towards the main bed. Indicate the adjustable parallel into the stationary parallel to within .002" on the In/Out and height. This lines the fixture up close so the block can be loaded and then use minor adjustments on the fixture to line the block up.

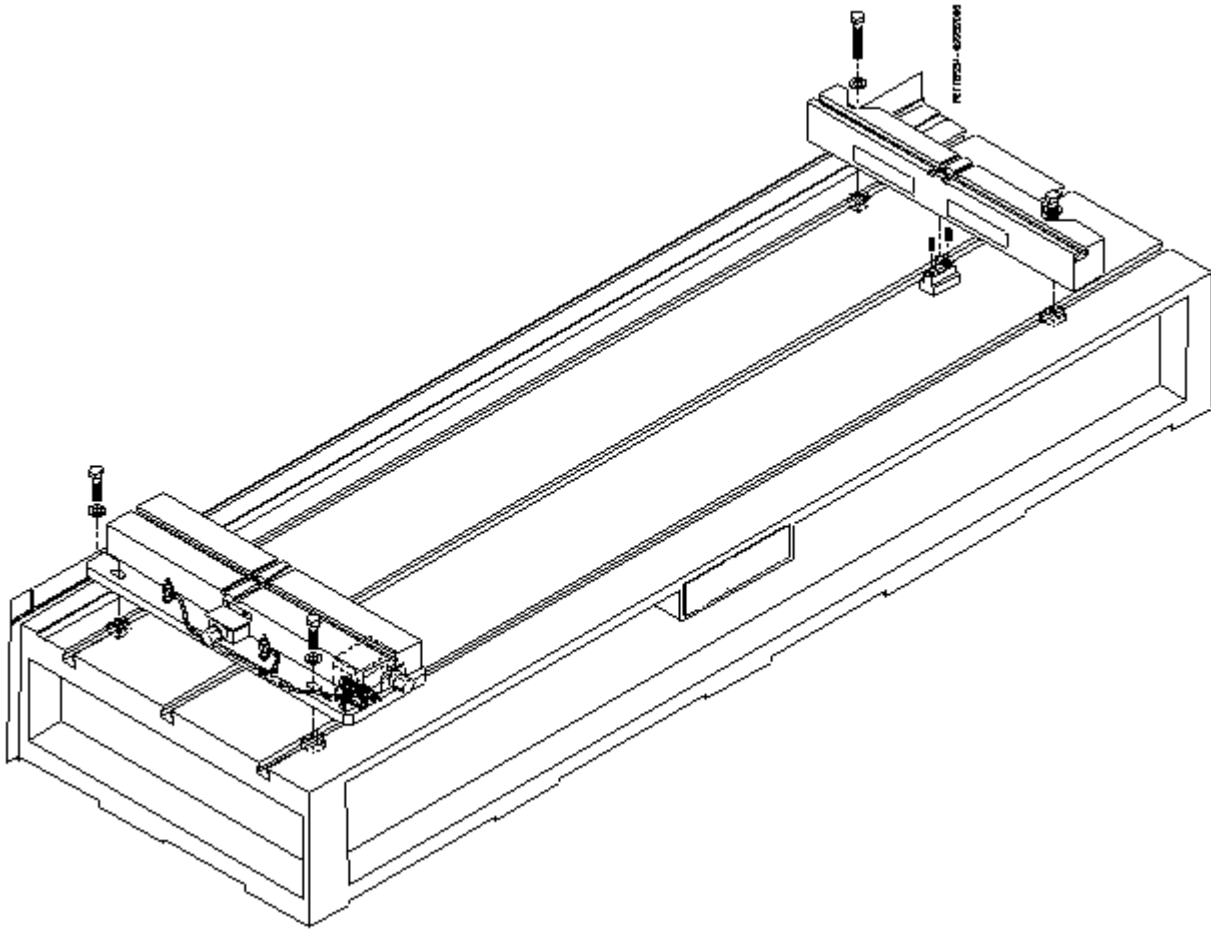

Select the set of V cradles for the block you are going to be machining. There are various types of cradles that can be used on this fixture. There are risers available also that can be mounted to the cradles to accommodate certain blocks. For cradle and riser selection refer to the Options section of this manual. The CAT 3500 series cradle is shown in this example.

Place the cradles on the parallel. Line up the horizontal key on the cradles with the key slot on the parallels. Generally, the rearward key slot is used, but on large blocks such as the CAT 3500, it is necessary to use the front key slot to allow clearance between the machine column, and engine block. Install mounting bolts and lock the cradles down. Due to the extreme weight of these blocks, clamping is usually not required. Threaded rods and clamp bars bridged across the cylinder bore, and threaded into the cradles is a way to secure the block if desired.

For in-line blocks, cradles are not used. In this case, round locators are bolted directly to the parallels. Lower the block with the end cylinders over the locators and push the block towards the front or rear. This will position the block in a straight line with the machine travel. Secure with threaded rods and clamp bars bridged across the cylinder bore, and threaded into the locators.

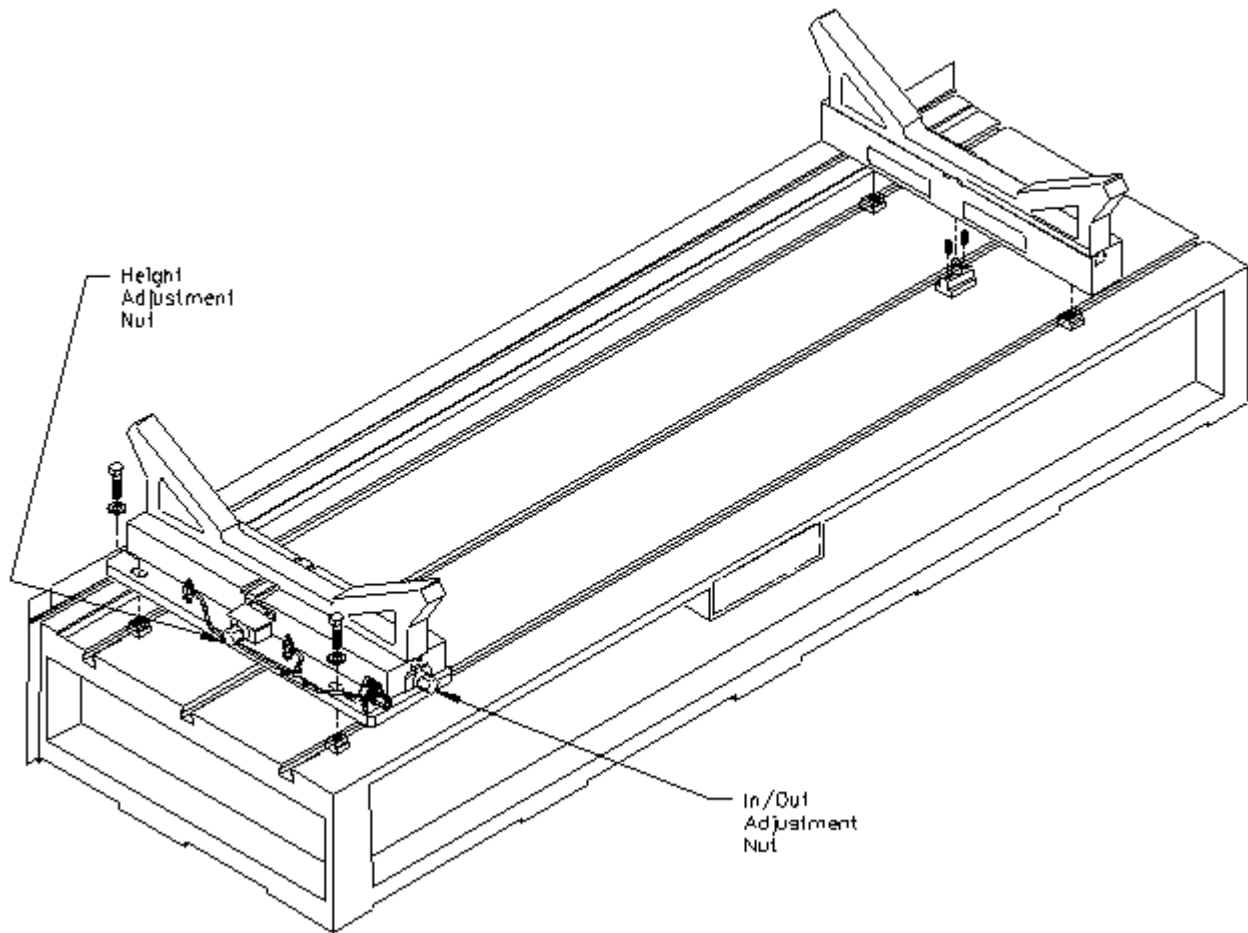

Lower the block slowly down into the cradles. Using a heavy soft mallet, tap the sides of the cradles to allow the block to settle into position. The block is now ready for alignment.

Up and down adjustment is accomplished by turning the screw on the side of the adjustable parallel. The in/out direction is adjusted by turning screw at the front of the adjustable parallel. Apply air pressure to the fixture while adjusting the in/out direction. Once the block is aligned, tighten down the fixture bolts and recheck alignment. Readjust as necessary.

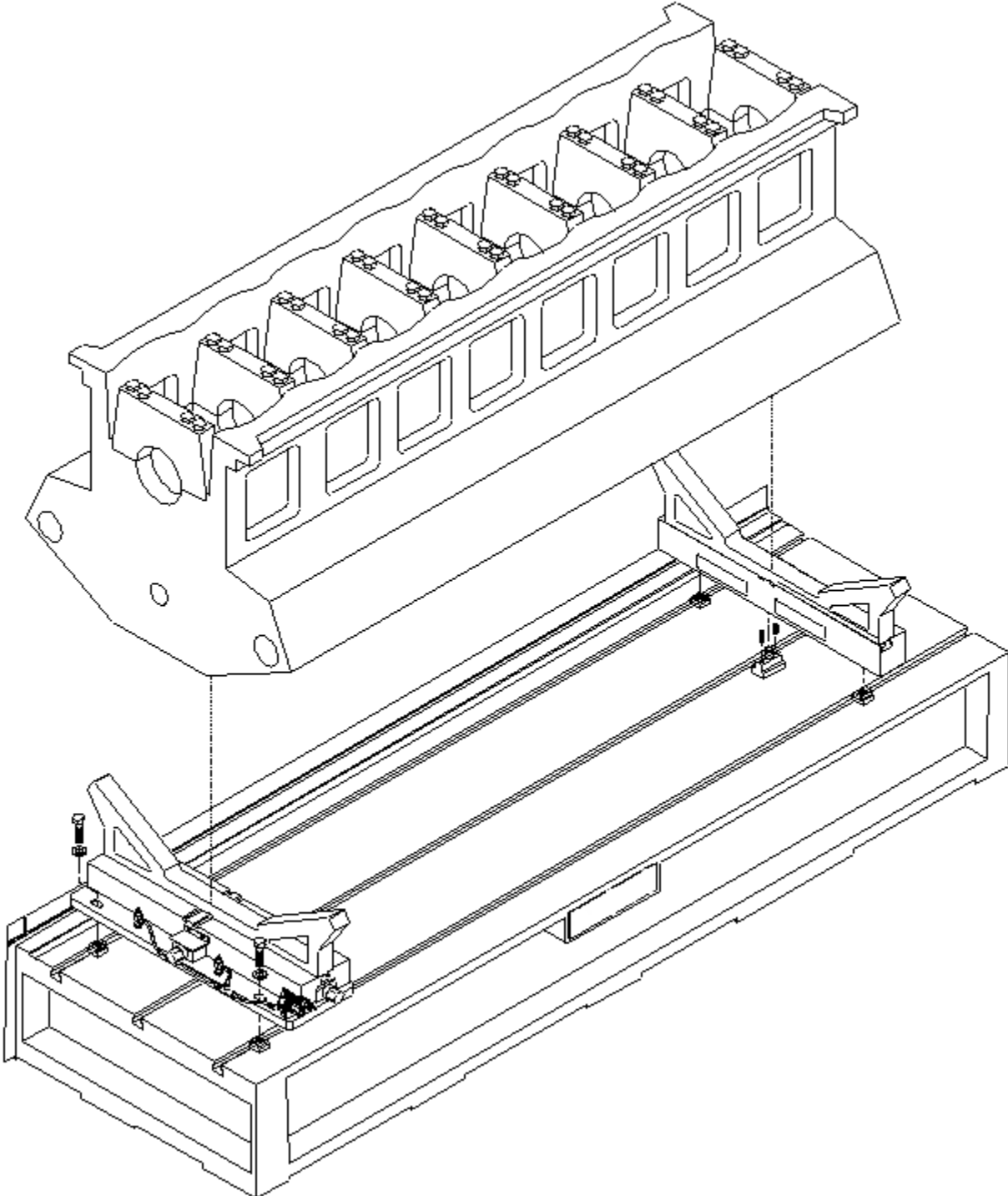



### 7119V Dual Axis Table Assembly

REFBUL90-120197

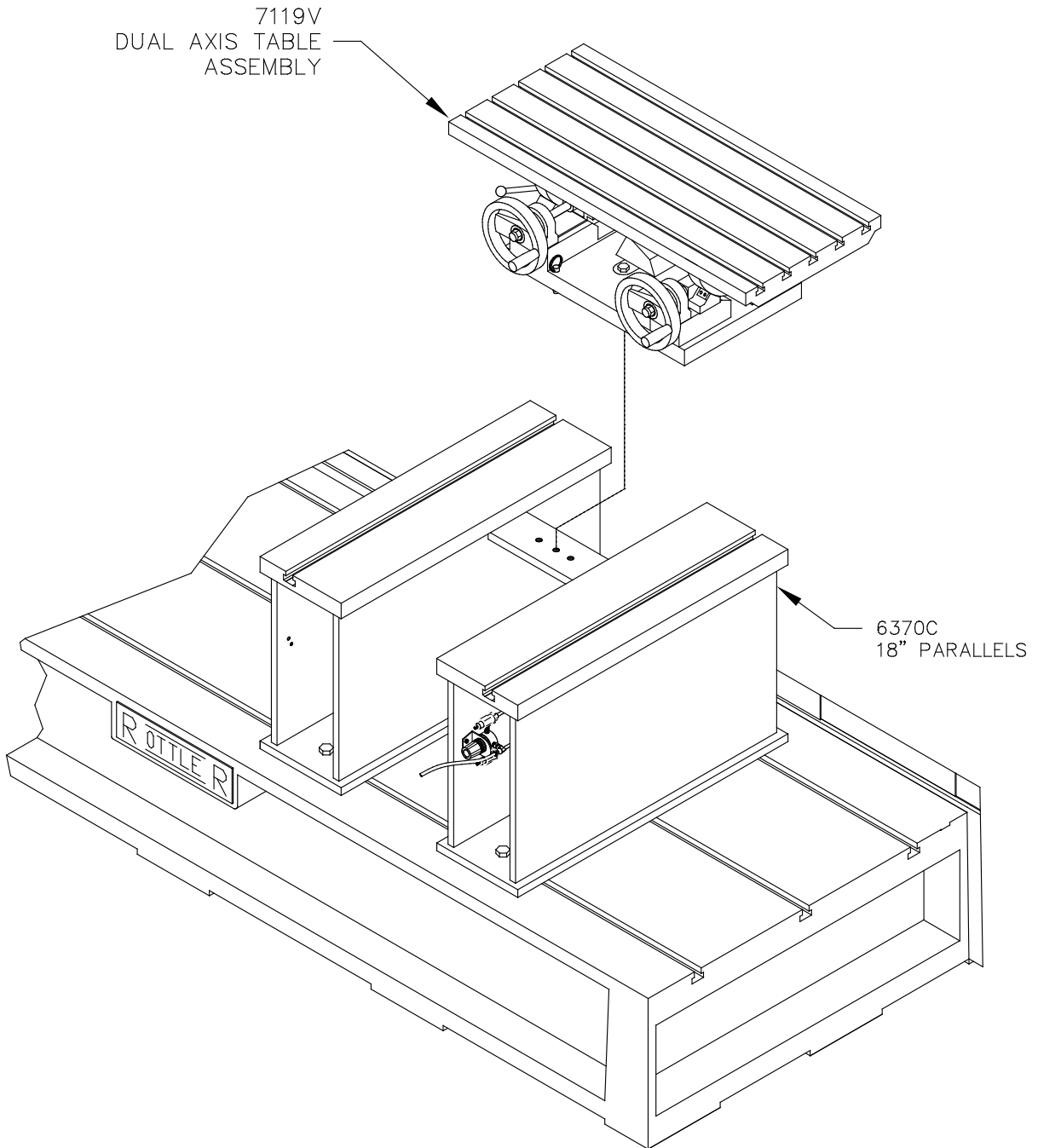

### Instructions for Small In-Line Blocks

The Dual Axis Table has the capability of holding small (less than 13 1/2" from pan rail to head surface) in-line cylinder blocks for resurfacing. This will require the use of parts from the 7119P Universal Head Fixturing package.

### Mounting Block to Table

There are two (2) methods for mounting blocks to the Table. Blocks with the main caps removed or with the raised main bearings can be mounted directly to the table surface. Block with the main bearing caps installed which are lower than the pan rail surface must be mounted using support blocks from the Universal Fixturing package.

### Blocks with Main Caps Removed or Raised Main Bearings

Remove any burrs from pan rails of block.

Locate cone washers on table to approximately center block in path of cutter-head and 'hook' the edge of the pan rail in the rear. Clamp the block using clamp handle assembly. We suggest you install the stop rod assembly on the left hand end of the block. This is an added safety precaution.

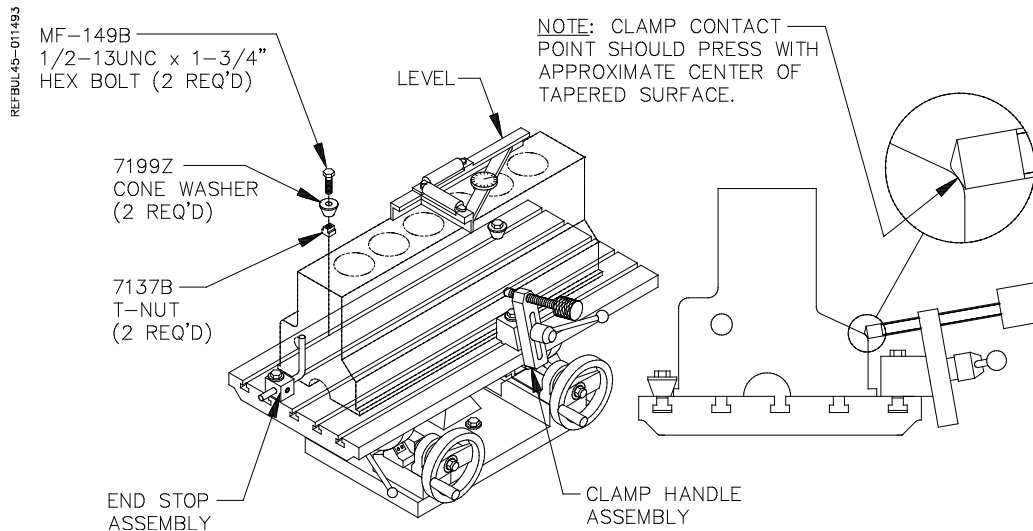

Check that all bolts and hold downs are tight. Loosen table clamp and level head surface of block in both directions. Lock table clamp and recheck block for level.

### Blocks with Main Caps Installed

Remove any burrs from pan rails of block.

Position rear supports and front supports to hold block approximately centered in path of cutter-head.

Generally, place the front supports closer together than the rear supports.

Place the block on the supports. Reposition the supports if necessary to clear main caps. Etc. Elevate the cones to hook the pan rail in the rear. Tighten set screws to lock cones in place. Tighten the hex bolts on the supports. Adjust the support block jack to eliminate any rocking. Lightly apply the clamp handle assembly.

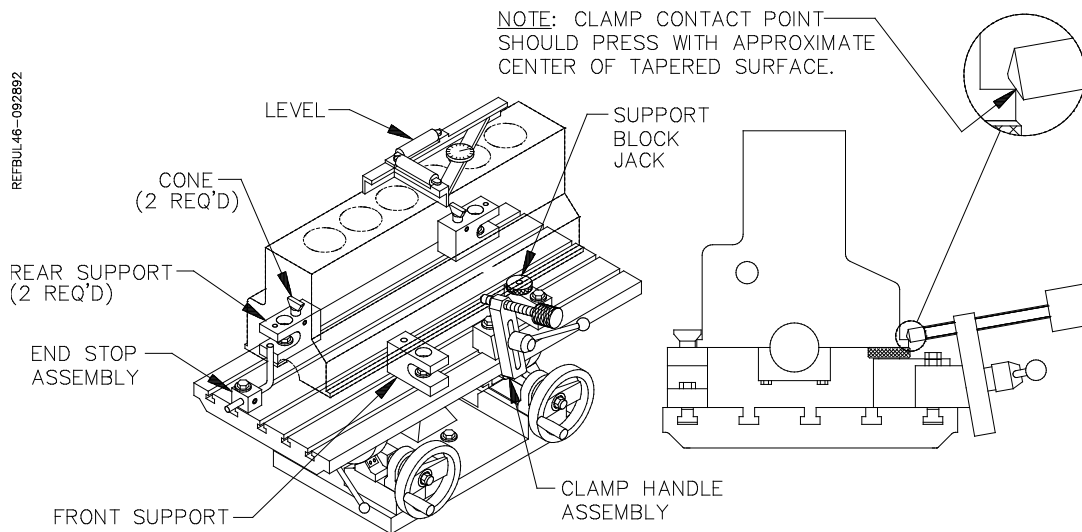

Loosen table clamp and level head surface of block in both directions. Lock table clamp. With the level still on the block tighten clamp handle assembly with appropriate clamp nose on the lower portion of a port or indent near the middle of the block. Tighten the clamp 1/8 to 1/4 turn after contacting the block. Do not over-tighten. Watch the level as you tighten to check for movement or warping. If the block moves or warps, repositioning the front supports inward will generally solve the problem. Check to see that the block cannot be moved in the fixture. We suggest that you install the stop rod assembly on the left hand end of the block. This is an added safety precaution.

### Typical Head Set Up Procedure

Find the desired ports or bosses, in the head, to position cones (long or short) on rear support blocks. Measure the distance between the centerlines of these ports (bosses) within 1/16" (1mm – 5mm). Measure the distance from rear support points to front support points on the head.

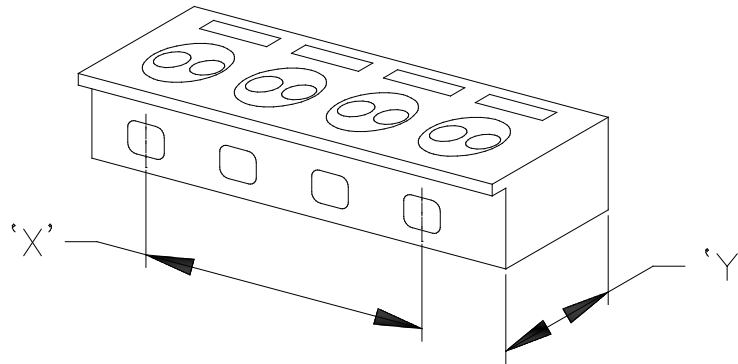

Position rear support blocks and front support blocks to hold the head approximately centered on the table top and spaced apart per dimensions measured in step '1' above. Generally, place the front blocks closer together than the rear blocks. If necessary, use either 2 or 4 spacers to raise the head for clearing studs or to angle the head so the cutterhead clears the head clamp handle assembly.

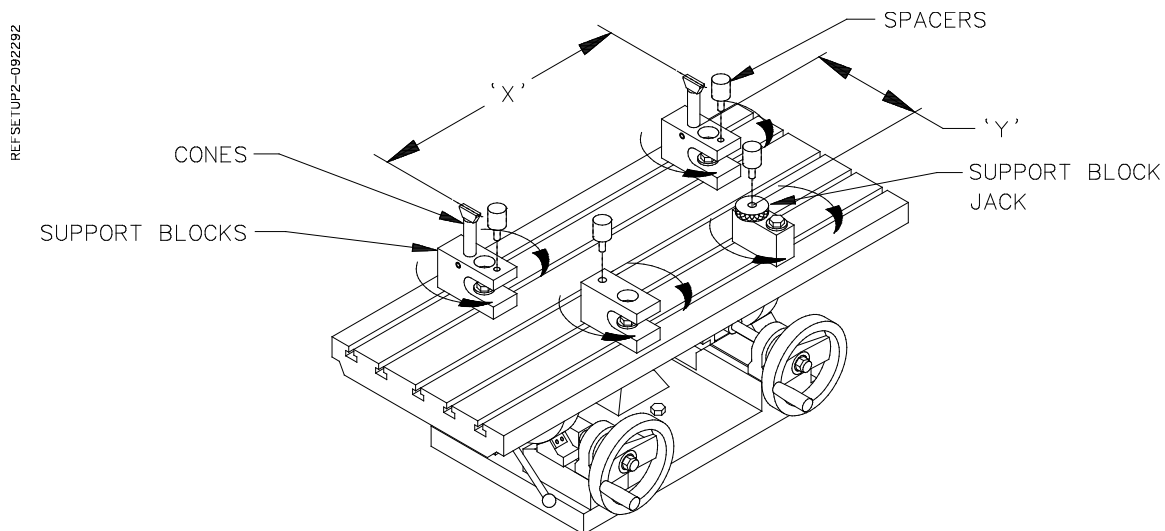

Place the head on the support blocks. Elevate the cones to 'hook' the two ports (bosses) on the head and tighten their set-screws. Adjust the position of the front support blocks if necessary. Tighten the hex bolts on the support blocks. Push the head back firmly into the cones. Adjust the support block jack to eliminate any rocking of the head. Do not tighten the head clamp handle assembly yet. Unlock the table. Using the two hand-wheels, level the head surface to be cut. Lock the table in this position.

REF SETUP3-092292

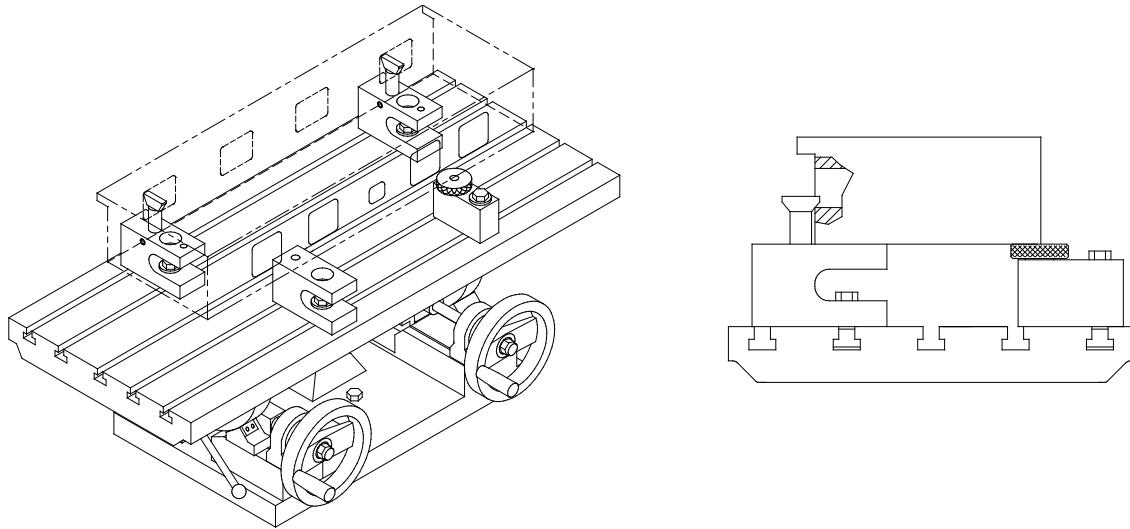

The head clamp handle assembly has a replaceable nose that pushes on the head. With the level still on the head surface, tighten the head clamp handle assembly on the lower edge of a port or indent near the middle of the head. Tighten the clamp 1/8 to 1/4 turn after contacting the head. Do not over tighten. Watch the level as you tighten to check for movement or warping. Some heads are very sensitive to support block placement, and the front support blocks may have to be moved slightly inward to prevent this warping. Check to see that the head cannot be moved in the fixture.

Slide the end stop block up against the left end of the head towards the rear. If possible, rotate the stop rod to contact a machined area on the end of the head. This will aid in loading a run of similar heads.

REF SETUP4-123192

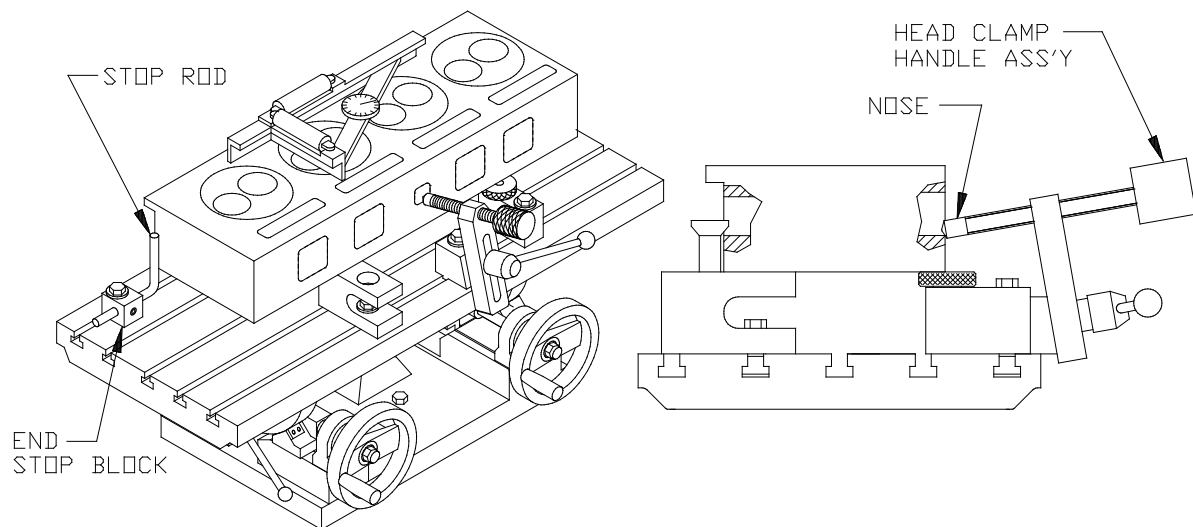

Visually check for clearance between the cutterhead and head fixture tooling pieces, especially the head clamp handle, assembly. The head should be approximately centered in the path of the cutterhead.

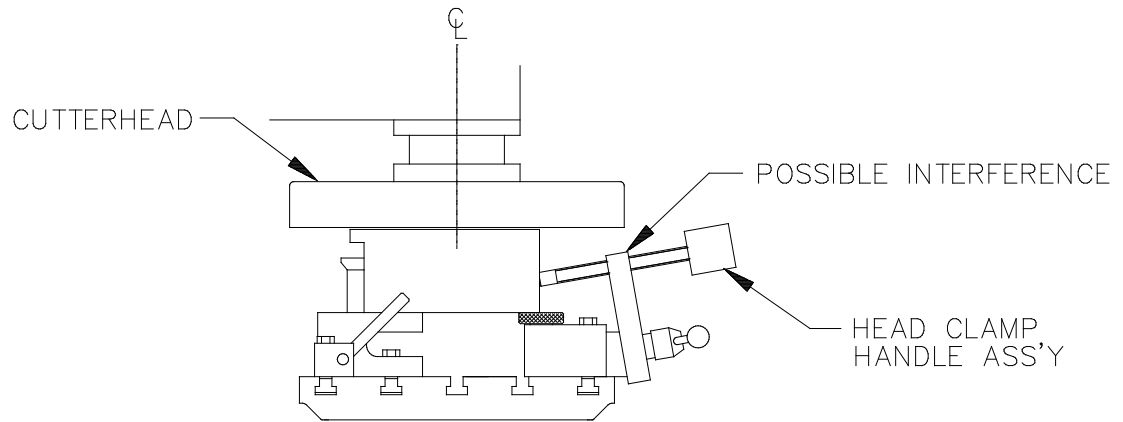

### **12" Multi Tooth Milling Head - 6865**

This milling head holds 14 insert cartridges. Each insert has 10 cutting edges, 5 on each side. The inserts need to be adjusted to be at equal height of each other to within .0004" (.01mm). To set the height of the inserts, install the milling head into the machine spindle. Install the inserts. Back off the small set screw above each tool cartridge. Loosen each tool cartridge, push up, and re-tighten.

Using an indicator with a large diameter convex tip, find the insert that is at the lowest setting. Now, adjust the remaining inserts to equal height by turning the small set screw above each tool cartridge.

There are a couple spindle motor parameters that need to be changed to gain more torque that this milling head requires.

Go to "Set up", then "General Options".

Find the line labeled "Spindle".

Find the column labeled "Position Gain", and change it to 10. (Record the original setting before changing)

Find the column labeled "Velocity Gain", and change it to 600. (Record the original setting before changing)

100 to 120 RPM and a feed rate of .020"(.05mm) to .040"(1mm) is recommended. Maximum depth of cut .020"(.05mm)

When finish with the machining operation, re-enter the original spindle motor settings as recorded earlier.

### **18" Multi Tooth Milling Head 6864**

This milling head holds 9 insert cartridges. Each insert has 10 cutting edges, 5 on each side. The inserts need to be adjusted to be at equal height of each other to within .0004" (.01mm). To set the height of the inserts, install the milling head into the machine spindle. Install the inserts. Back off the small set screw above each tool cartridge. Loosen each tool cartridge, push up, and re-tighten.

Using an indicator with a large diameter convex tip, find the insert that is at the lowest setting. Now, adjust the remaining inserts to equal height by turning the small set screw above each tool cartridge. Install the dampener band around the perimeter of the milling head.

There are a couple spindle motor parameters that need to be changed to gain more torque that this milling head requires.

Go to "Set up", then "General Options".

Find the line labeled "Spindle".

Find the column labeled "Position Gain", and change it to 10. (Record the original setting before changing)

Find the column labeled "Velocity Gain", and change it to 600. (Record the original setting before changing)

Find the column labeled "Accel Rate", and change it to 2. (Record the original setting before changing)  
70 to 90 RPM and a feed rate of .020"(.05mm) to .040"(1mm) is recommended. Limit the depth of cut to .001" (.025mm) to .002" (.05mm)

When finish with the machining operation, re-enter the original spindle motor settings as recorded earlier.



## Right Angle Drive Installation

Move the Rotate the inner spindle to position the keyway toward the left, in line with the outer spindle keyway notch. Press the tool release switch to compress the drawbar.

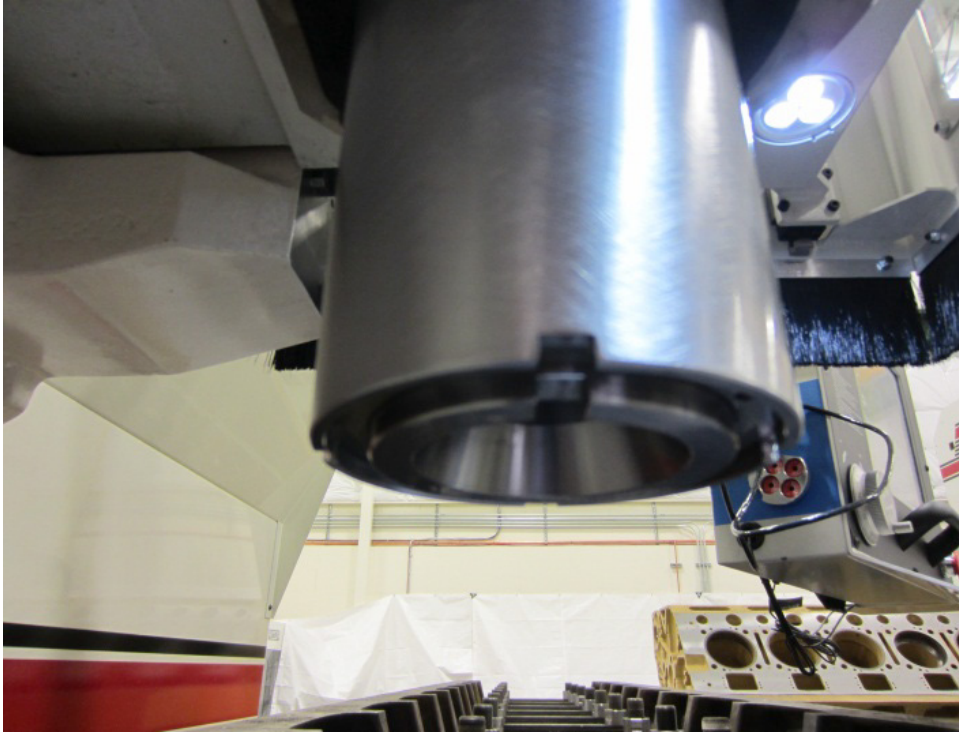

Rotate the RAD driveshaft so the drive key is pointing to the front or rear.

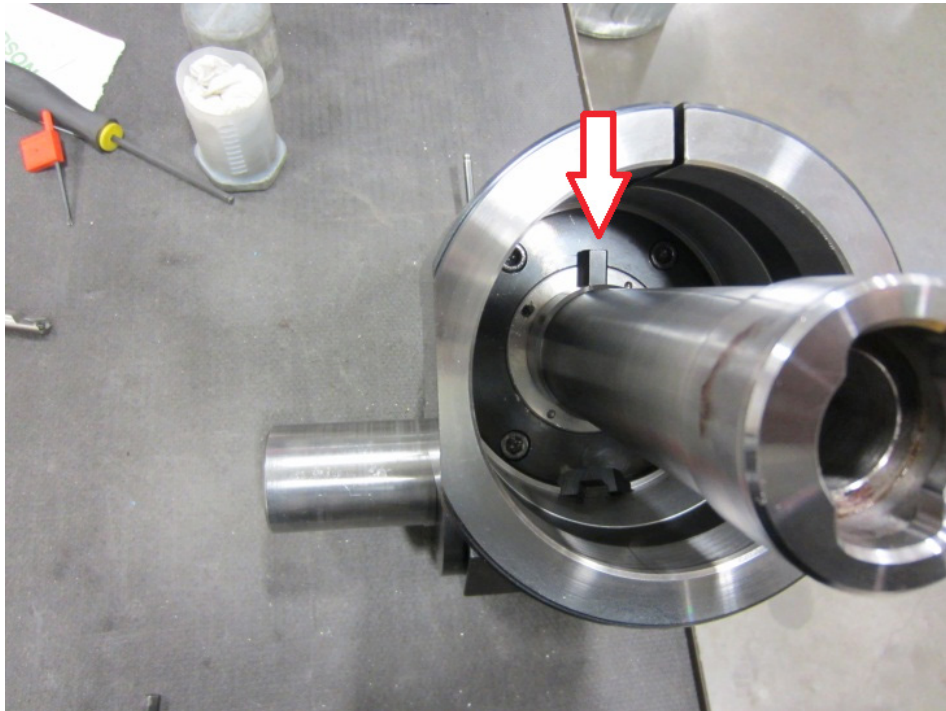



Carefully insert the RAD driveshaft into the inner spindle and lift the unit upward as far as it will go. Rotate the RAD output shaft until the driveshaft key is lined up with the inner spindle keyway. This will be visible through a small window on the left side of the RAD hub. At this point, the RAD will not fall out, so holding it in place is not required.

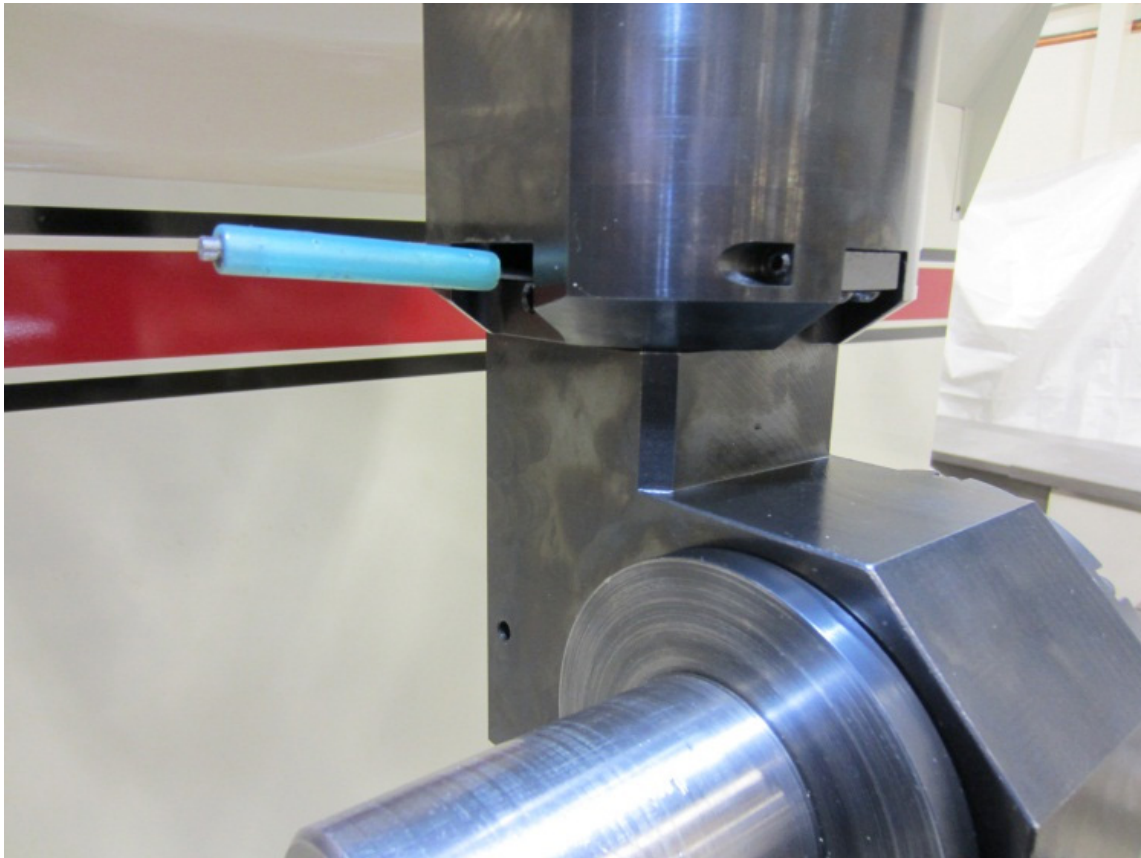

There are two adjustable keys on the RAD mounting hub that need to be lined up with the keyway notches of the outer spindle. It is not possible to see that these are aligned, so it is a little bit of trial and error when installing the unit. If the unit has never been installed on this particular machine, it would be best to temporarily remove these keys during the initial installation.

Before rotating the tool engage the drawbar to finish installing the unit, using a small shim under the inner spindle drive key in case it is not perfectly aligned to prevent bending of the key. A small flat screwdriver works well.

***NOTE: Verify that the RAD hub is against the bottom face of the outer spindle. If not, the inner, or outer keys, are not lined up, repeat the prior procedure until it is correct.***

At this point, the RAD must be aligned so that the hub face is 90° to the travel of the X axis. With an indicator touching the output face of the RAD, move the Y axis back and forth to see the amount of error.

There are two (2) adjusting set screws and an adjustment block on the RAD hub. The two set screws push against the adjustment block to turn the head left or right. The adjusting block is keyed to the outer spindle. The two screws mounting the adjusting block to the hub need to be slightly loose.

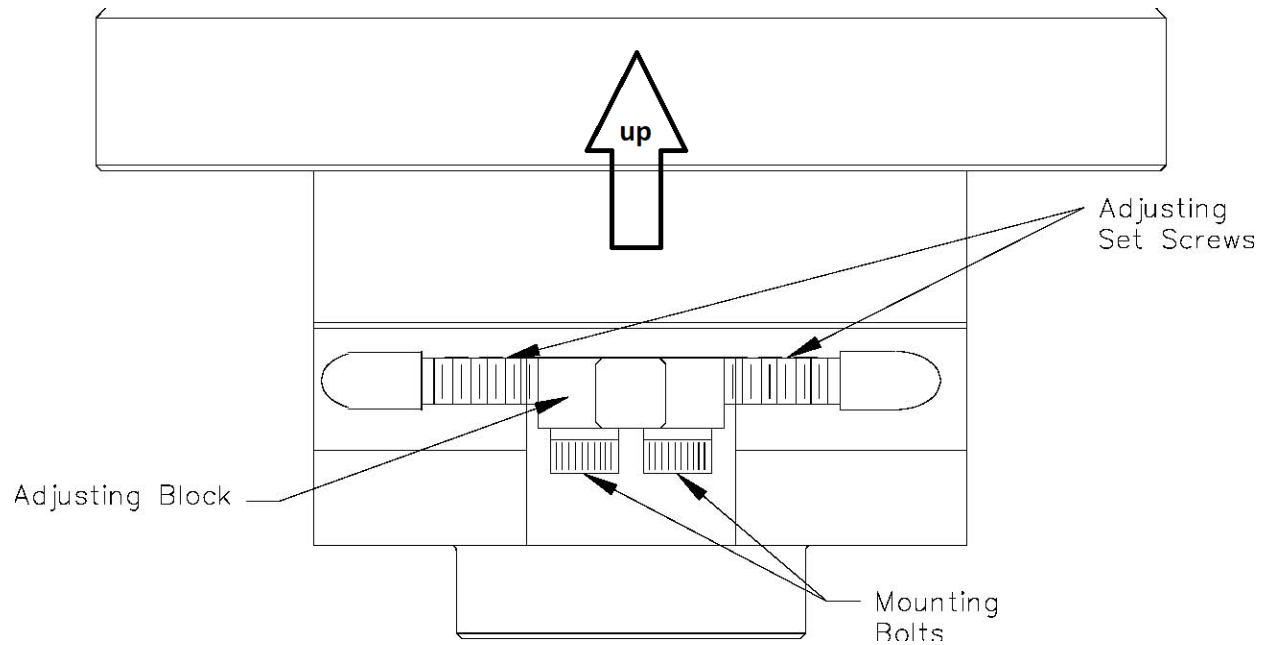

Start turning the set screw that will rotate the RAD in the direction you need to go. The set screws will rotate the unit counter clockwise or clockwise. The set screw will move the key on the adjusting block until it hits the keyway in the outer spindle. As you are turning one set screw you will need to keep the opposite set screw backed off, it will stop.

Final alignment results should be less than .0005" (.025mm), or as close as possible.



Tighten the two hub clamping bolts located at the rear of the unit. Tighten to 30 ft. lbs. (41 N m ) Recheck Alignment and re-adjust if necessary.

## General Machine Information

Before starting to build or use any of the Rottler operating programs it is important to understand how the machine operates internally.

The Rottler F103/4/5A model uses Computerized Numeric Control (CNC). The CNC is always operating when the machine is turned on. However, you will not see the CNC controls unless you switch over to the CNC operating screen.

## Homing

The F103/4/5A MUST be homed anytime it is turned off. If the machine has not been homed the reference positions for all programs will be off.

The purpose of Homing the machine is to set reference points in each axis for the machine to operate from. If the machine is not homed the reference points may be off position. The reference point is set in exactly the same position each time the machine is homed. The machine keeps track of these reference positions internally and the operator will not see them.

## Building Programs

NOTE: The instructions in this section are done WITHOUT using tool or Fixture offset values.

### Create a Block Program

Block Programs are listed on the left hand side of the screen. Mode programs that are for a specific Block Model are listed on the right side of the screen.

### New

From the Program Select screen select New from the Left hand menu. This will open a window where will enter the Block name and configuration i.e. V6, V8 or Inline and number of cylinders.

NOTE: There is an existing program on start-up of new software called Part Program. This can be deleted after the first Block Program is entered.



## Options

If you need to change the block configuration or name of a block that has already been created, use the Options button. This will bring up the same window as when the block was created.

## Creating Operating Modes for a Block Model

Select the Block model on the left hand side of the screen.

## New

Selecting New will bring up a window that lists all the Modes that can be performed on the selected block model. Highlight the Mode you want to create and press OK.

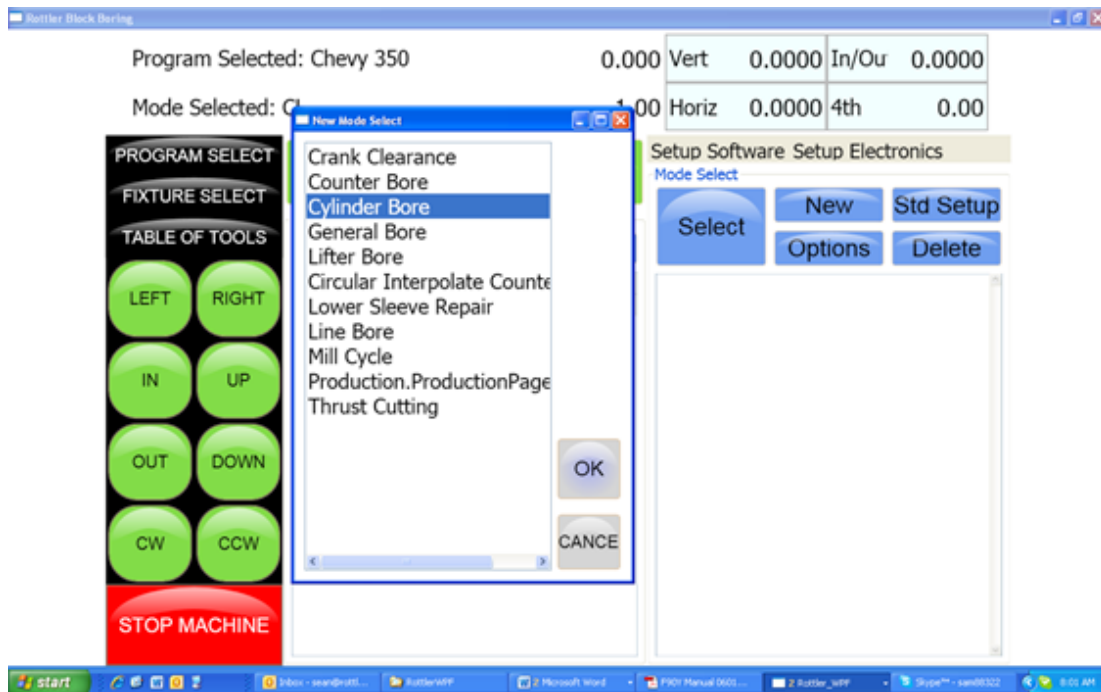

The selected mode will show up on the right hand side of the screen.





## Std (Standard) Setup

Pressing Std Setup will cause all of the available Modes to be inserted into the Modes area on the right hand side.



## Select

Pressing Select with a Mode highlighted will open the operations screens for using the program.

## Options

Pressing the Options button with a Mode highlighted will open a window where you can change the mode name. There is also a check box to allow positive number to be entered into the program where they are normally forced to a negative value.

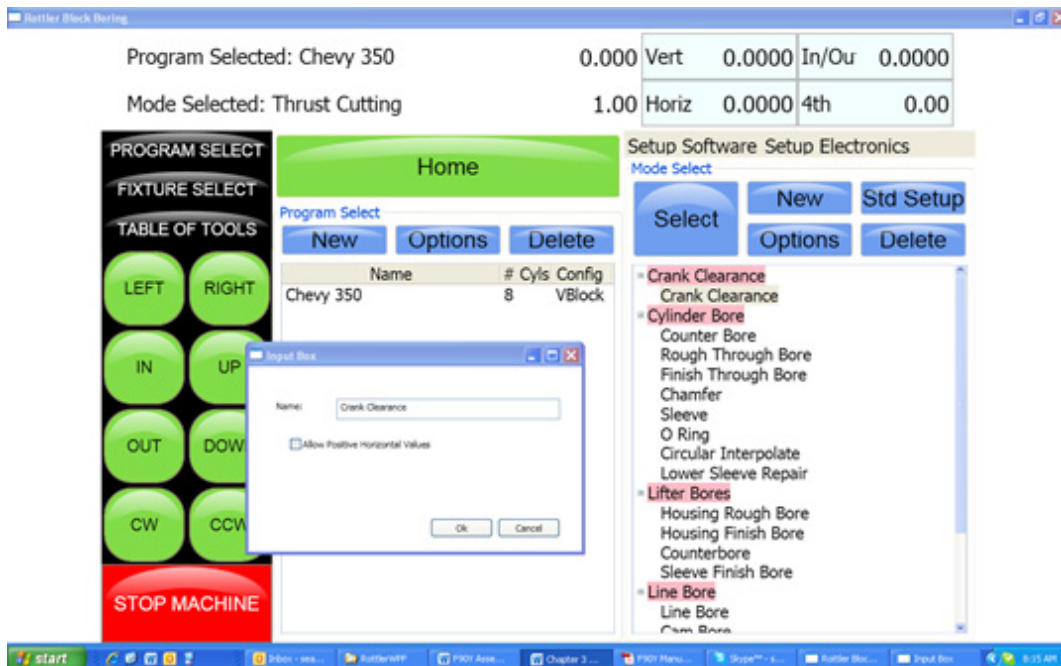

### Cylinder Bore Mode 3 Axis

Select Cylinder Bore and then Rough Through Bore on the screen. This will bring up the boring program with the Set Zeros tab shown.

NOTE: Once a certain feature is discussed in a particular mode it will not be discussed again in the following modes.





### Setting Zeros

The purpose of setting zero points is to give the operator a specific point to build programs from. The machine also uses these zero points to run the program from. The zero points can be set at any point in the machines' travel. Each axis (except the Spindle rotation) will need to have a zero point set for the machine to operate from. Every program will save its individual zero positions. The next time that program is selected the zero position will be the exact same distance from the Home position for each axis.

### Horizontal and In/Out Zero

For this example, the Dowel Pin will be our zero point for the Horizontal and In/Out axis. Using an indicator or electronic probe center the spindle on the Dowel Pin then press the Horizontal and In/Out Zero buttons. The display next to these buttons will go to zeroes. The Horizontal and In/Out zero positions have now been set.

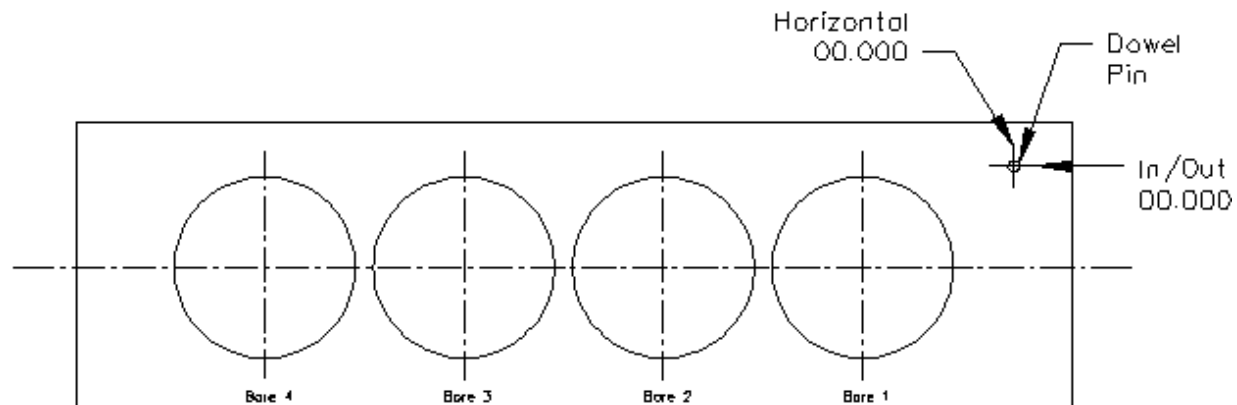

### Vertical Zero

There are three different ways to use the boring software, Blueprinting, Indicating and Probing. It is not unusual for all three modes to be used on the same size block. The vertical stops for these different operating programs will vary. Be sure the vertical stops are set correctly for the mode you are using.

For this example the deck will be our zero for the Vertical axis. Insert a tool holder into the cutterhead you will be using to bore the block. Center the cutterhead over a cylinder. Using the Vertical Handwheel, bring the cutterhead down until the tool just touches the deck and press the Vertical Zero button. The display next to this button will go to zero. The Vertical zero has now been set.

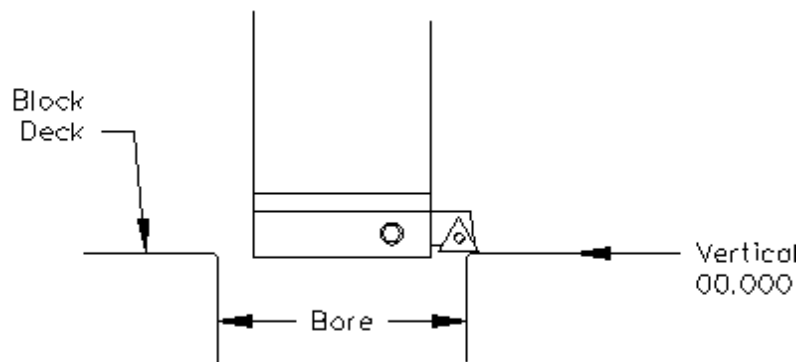

The zeros points for all axis have now been set. All the numbers entered from this point on will reference these zero positions. You are finished with the Set Zeros screen, select the next Tab to the Right, Vertical Stops.

## Blueprinting

Even if you are not going to be boring a block to the blue print specifications it is recommended to have the Blueprint values entered. It will speed up the process of indicating and probing a block by giving the operator a close estimate of bore location.

## Programming Vertical Stops

To build a program you must set the Vertical Stops for the program.

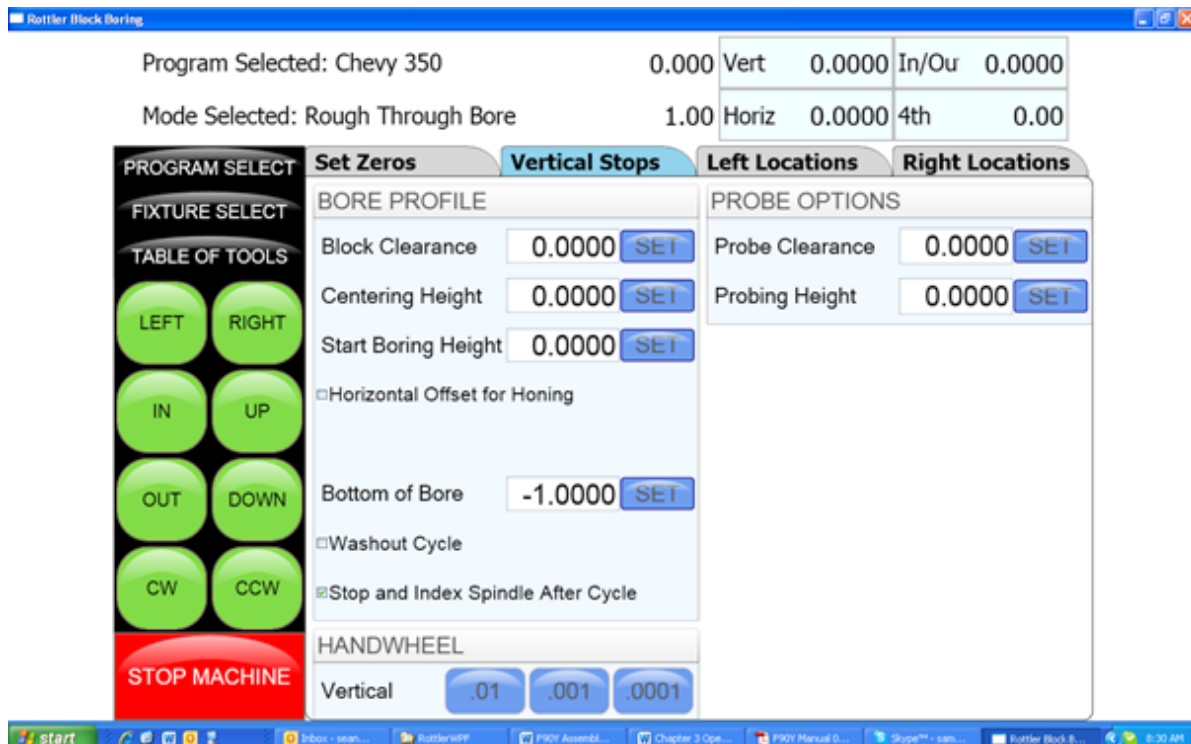

## Block Clearance

This is the distance above the zero position or block deck allowing the cutterhead to move to the next bore unobstructed. If you are Blueprinting a block the number will be just enough to allow the cutterhead to clear the block deck.

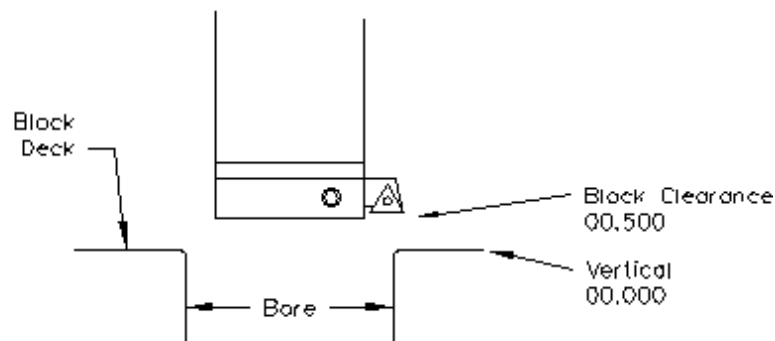

## Centering Height

When Blueprinting this stop is not needed. It should be the same as the block Clearance Height.

## Start Boring Height

This is the distance above zero or the block deck where you want the cutterhead to start rotating and the downward feed to start. Generally this is just a short distance above the block deck to minimize the amount of time the machine bores through air.

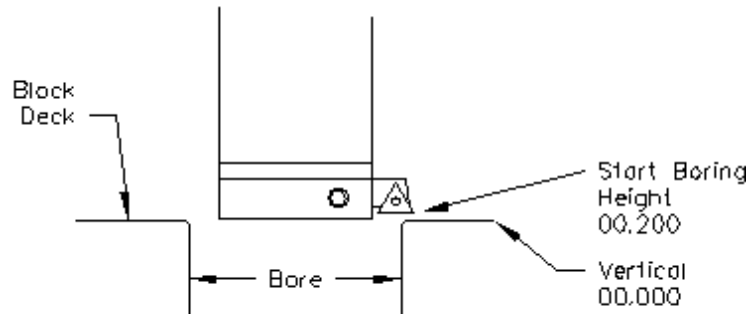

## Bottom of the Bore

This is the distance below zero or the Block deck where you want the machine to stop boring and retract out of the cylinder. When the spindle retracts it will then go to the Block Clearance position. This is an example of what the above program would look like on the vertical stops.

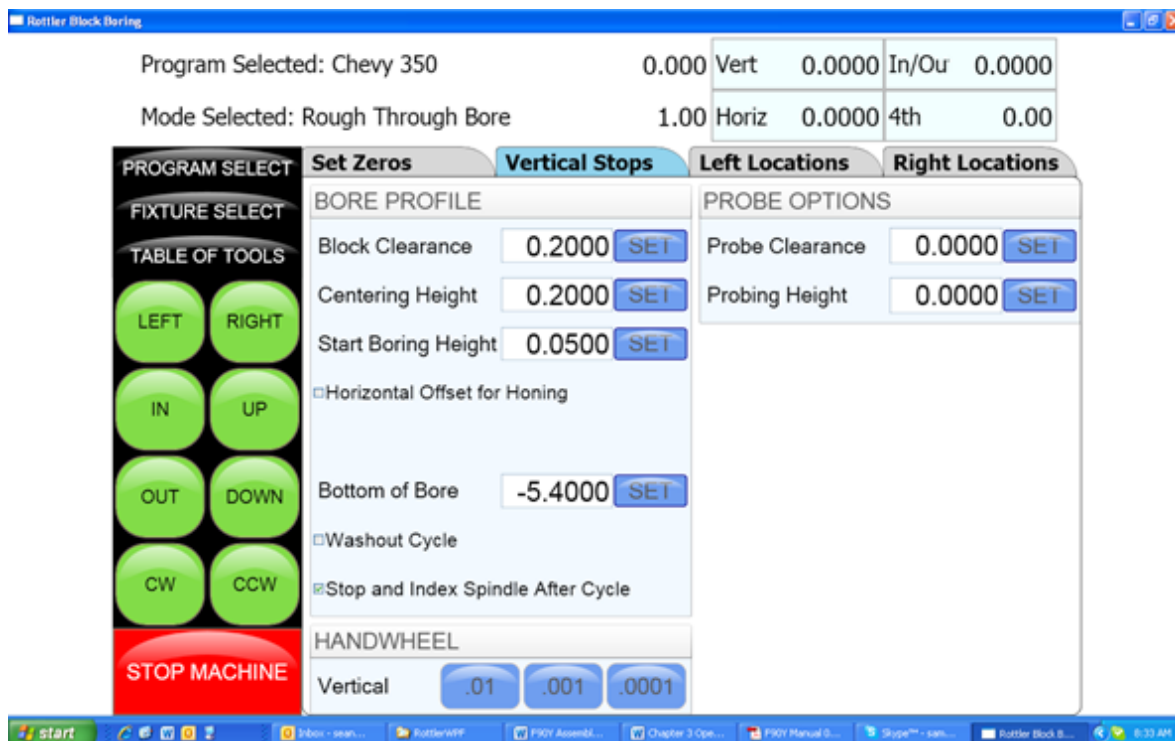

When Blueprinting the Probe is not used. It will be discussed later in this Chapter.

## Horizontal Offset for Honing

This feature is designed to offset the cutter at a certain height in the lower bore to cut out block web intrusions to make room for the honing process.

Checking this box will bring up another value to be entered on the left hand side of the screen.

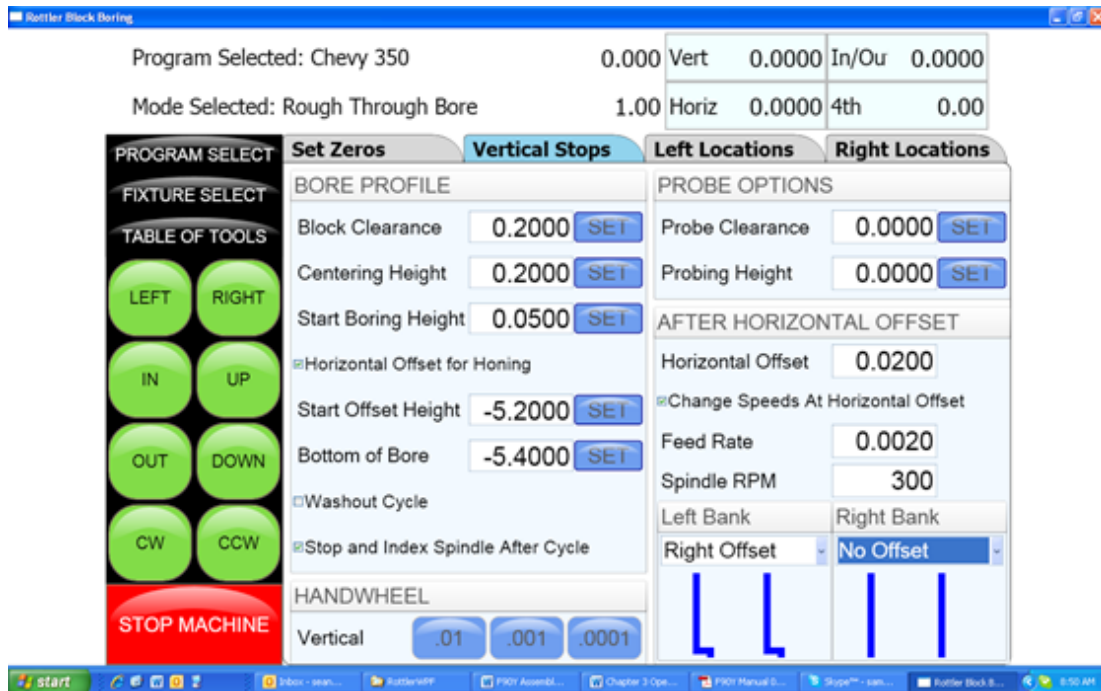

### Start Offset Height

This is the vertical depth at which the cutter will shift to the side to start cutting.

### Horizontal Offset

This is the distance the cutter will offset from the bore center.

### Change Speeds at Horizontal Offset

Often the clearance cut is much larger than the cut for the rest of the bore. For this you can check this box and enter a different RPM and Feed Rate. If a different speed and feed are not needed do not check this box and the same feed and speed will be used that was used to bore the cylinder.

For each bank (of a V Block) you can select the direction the offset should go.

### Washout Cycle

Checking this box will open another window on the right hand side of the screen. Here you can enter the RPM and number of revolutions that will be performed when the cutter reaches the Bottom of Bore position. In Through Boring this is not generally used. This is used when a certain type of finish is required on a counter bore or the bottom of a sleeve cut.

### Stop and Index Spindle after Cycle

Checking this box will cause the spindle to be indexed to the three O'clock position after the cylinder has been bored but before it retracts. It will also offset to the left before the tool is retracted. This is the default setting. You would not want this check in an operation such as Lifter Boring.

## Bore Locations

To build a program you must set the Horizontal and In/Out Stops for the program. All Horizontal and In/Out stop are based from where their zero positions were set. The following illustration shows how the stop positions were derived. These stops would be used when blueprinting a block.

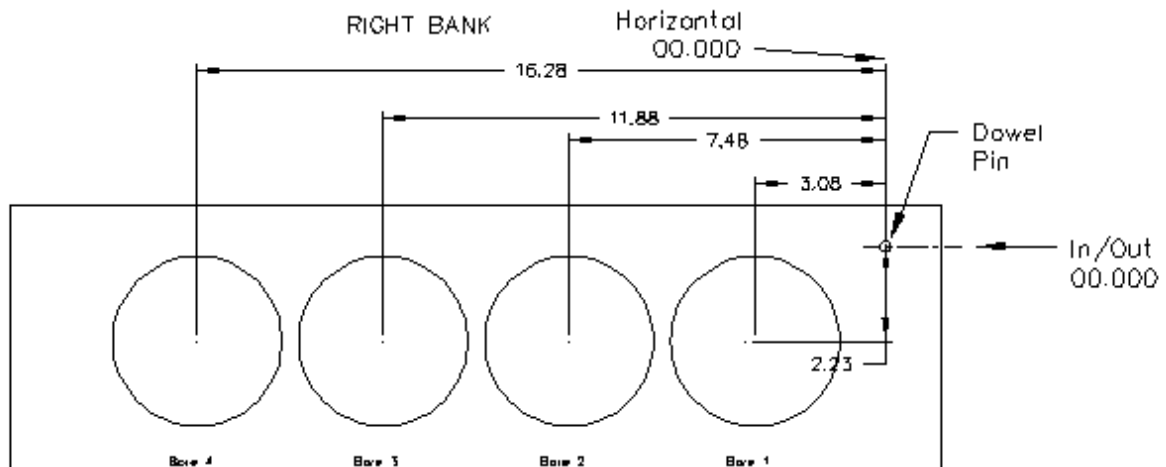
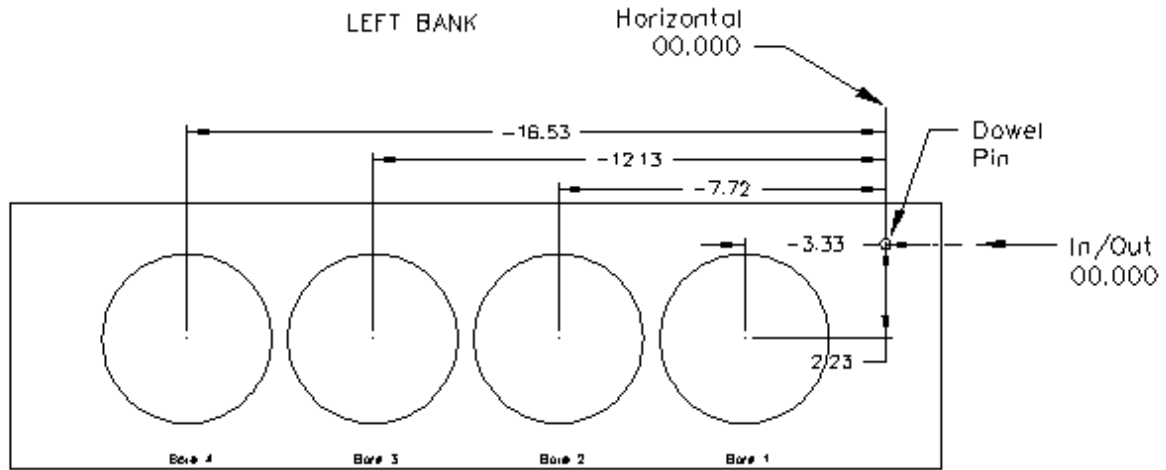

The following is an example of what the screens would look like for the above block.

### Left Locations

Program Selected: Chevy 350 0.000 Vert 0.0000 In/Ou 0.0000  
 Mode Selected: Rough Through Bore 1.00 Horiz 0.0000 4th 0.00

Set Zeros	Vertical Stops	Left Locations	Right Locations	
Blueprint	Indicated	Probed	Difference	
Copy Values	MOVE 1	MOVE 2	MOVE 3	MOVE 4
Horizontal	-3.3300	-7.7200	-12.1300	-16.5300
In/Out	2.2300	2.2300	2.3000	2.2300
	BORE 1	BORE 2	BORE 3	BORE 4

HANDWHEEL  
 Vertical .01 .001 .0001  
 Horizontal .01 .001 .0001 4th .010 .001  
 In Out .01 .001 .0001 Spindle 10x Coarse

CONTROL PANEL: LEFT, RIGHT, IN, UP, OUT, DOWN, CW, CCW, STOP MACHINE, PROBE LEFT, BORE LEFT

### Right Locations

Program Selected: Chevy 350 0.000 Vert 0.0000 In/Ou 0.0000  
 Mode Selected: Rough Through Bore 1.00 Horiz 0.0000 4th 0.00

Set Zeros	Vertical Stops	Left Locations	Right Locations	
Blueprint	Indicated	Probed	Difference	
Copy Values	MOVE 1	MOVE 2	MOVE 3	MOVE 4
Horizontal	-3.0800	-7.4800	-11.8800	-16.2800
In/Out	2.2300	2.2300	2.2300	2.2300
	BORE 1	BORE 2	BORE 3	BORE 4

HANDWHEEL  
 Vertical .01 .001 .0001  
 Horizontal .01 .001 .0001 4th .010 .001  
 In Out .01 .001 .0001 Spindle 10x Coarse

CONTROL PANEL: LEFT, RIGHT, IN, UP, OUT, DOWN, CW, CCW, STOP MACHINE, PROBE RIGHT, BORE RIGHT

The Horizontal and In/Out stops have now been set.

## Boring a Block

Once the Vertical, Horizontal and In/Out stops have all been entered the Spindle RPM and Feed Rate need to be entered. This is done on the Set Zeros screen. Once this is done you can go to the Left and/or Right Bore location screens and bore the cylinders.

Pressing the Bore Left for Bore Right buttons Will Bore all the cylinders that have Green bore button below them.

Pressing a Bore button once will turn that button Yellow. Any Yellow button will not be bored when the Bore Left or Right button is pressed.

Double clicking any Bore button will turn all the Bore button yellow EXCEPT the one that was double click.

## Indicating

Even if you are not going to be boring a block to the blue print specifications it is recommended to have these values entered. It will speed up the process of indicating and probing a block by giving the operator a close estimate of bore location.

### Vertical Zero

There are three different ways to use the boring software, Blueprinting, Indicating and Probing. It is not unusual for all three modes to be used on the same size block. The vertical stops for these different operating programs will vary. Be sure the vertical stops are set correctly for the mode you are using. For this example the deck will be our zero for the Vertical axis. Insert a tool holder into the cutterhead you will be using to bore the block. Center the cutterhead over a cylinder. Using the Vertical Handwheel, bring the cutterhead down until the tool just touches the deck and press the Vertical Zero button. The display above this button will go to zero. The Vertical zero has now been set.

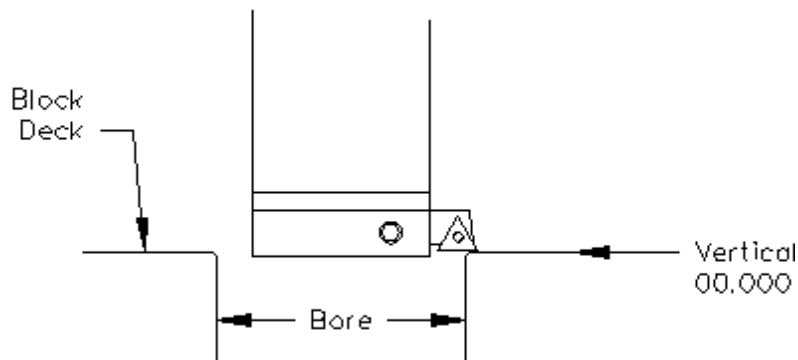

The zeros points for all axis have now been set. All the numbers entered from this point on will reference these zero positions. You are finished with the Set Zeros screen, select the next Tab to the Right.



## Programming Vertical Stops

To build a program you must set the Vertical Stops for the program.

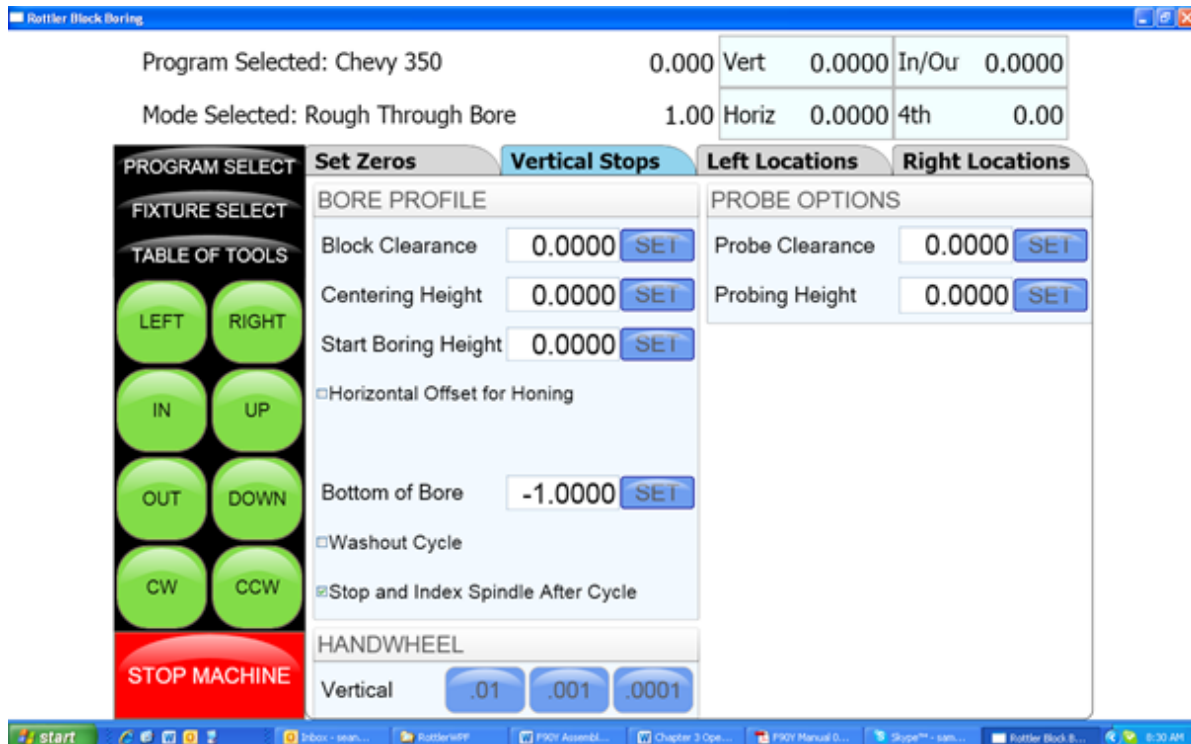

## Block Clearance

This is the distance above the zero position or block deck allowing the cutterhead to move to the next bore unobstructed. When you are indicating the cylinders in you must have this stop set so the indicator will clear the block surface when traveling to the next cylinder.

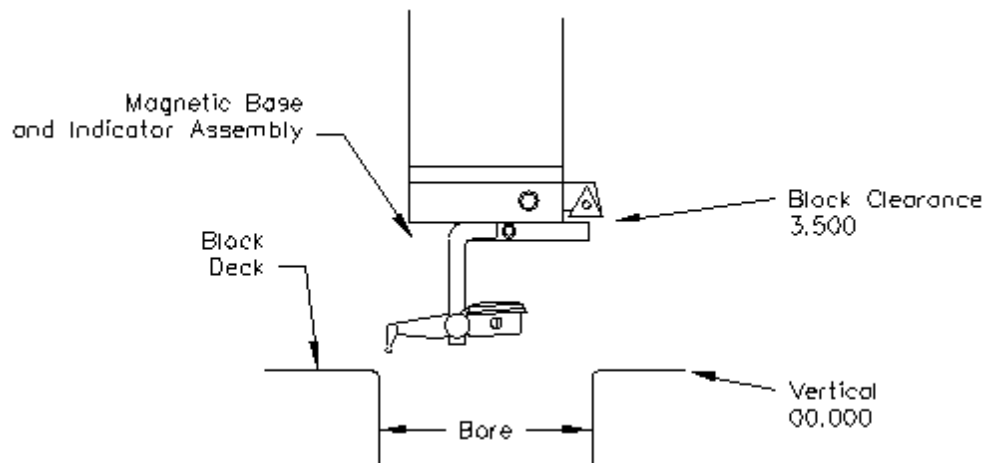

### Centering Height

This is a distance above the vertical zero where you will be manually centering the block. The drawing below is a typical set up for manual centering or indicating a cylinder.

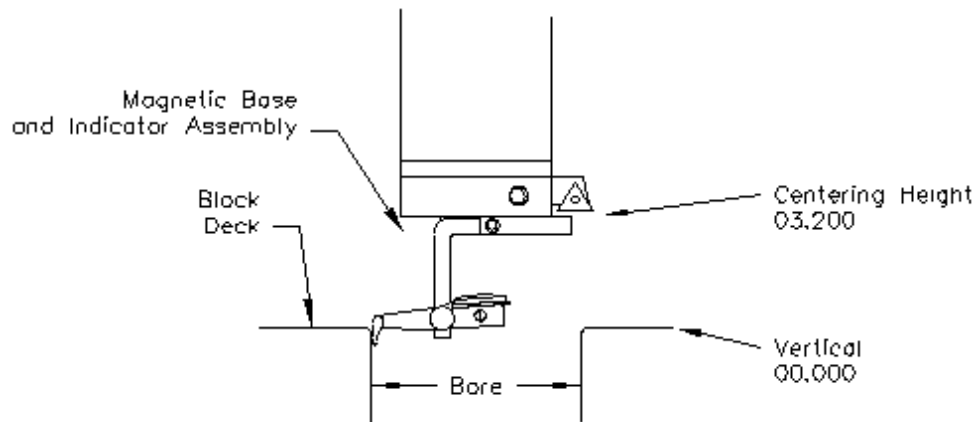

### Start Boring Height

This is the distance above zero or the block deck where you want the cutterhead to start rotating and the downward feed to start. Generally this is just a short distance above the block deck to minimize the amount of time the machine bores through air. This will be a negative number.

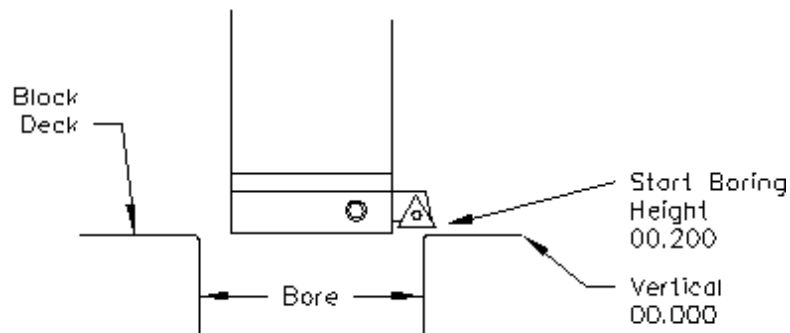

## Bottom of the Bore

This is the distance below zero or the Block deck where you want the machine to stop boring and retract out of the cylinder. When the spindle retracts it will then go to the block Clearance position. This is an example of what the above program would look like on the vertical stops.

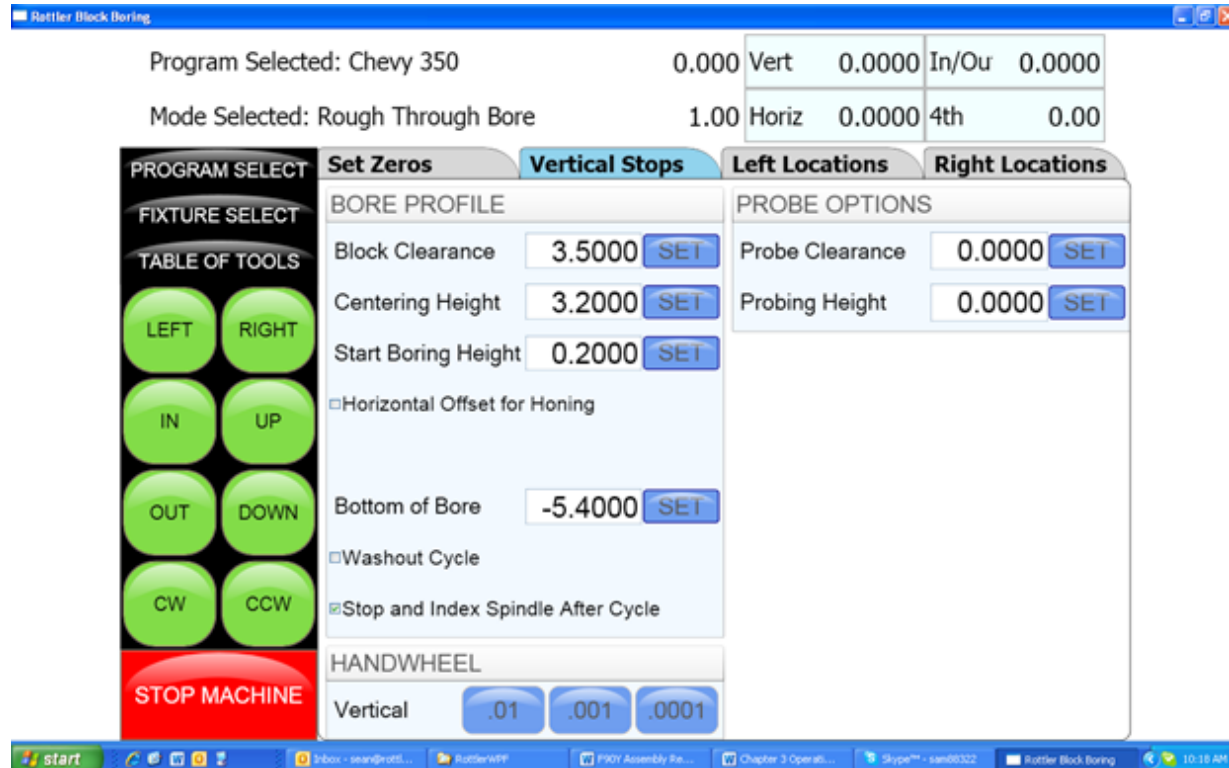

The Vertical stops have now been set. You are finished with the Vertical Stops screen, select Left and/or Right Locations.

## Bore Locations

To build a program you must set the Horizontal and In/Out Stops for the program. There are eight (8) Horizontal and In/Out stops used in the boring program. All Horizontal and In/Out stop are based from where their zero positions were set.

Select Left Locations and the Blueprint. Program the blueprint values (or close approximation) into the Horizontal and In/Out stops. Do the same for the Right Locations.

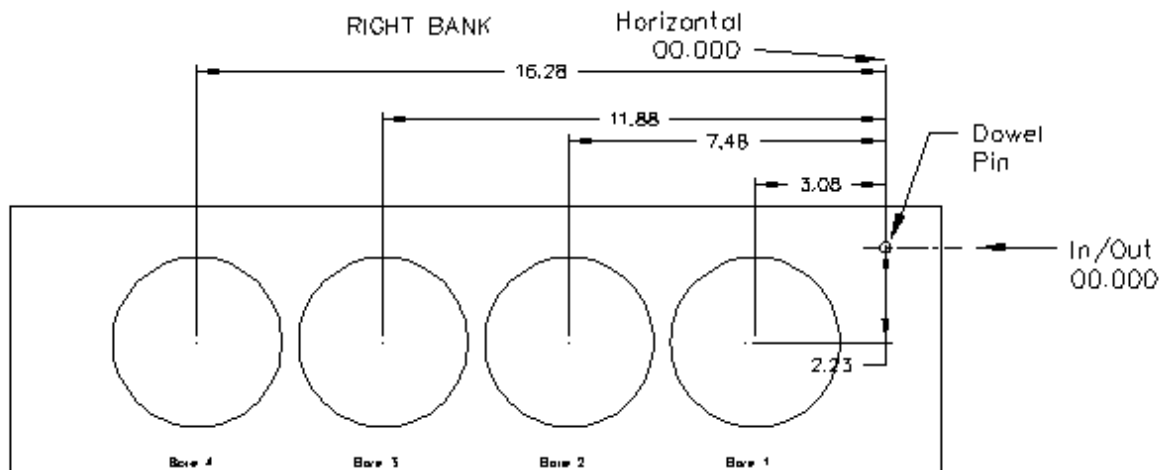
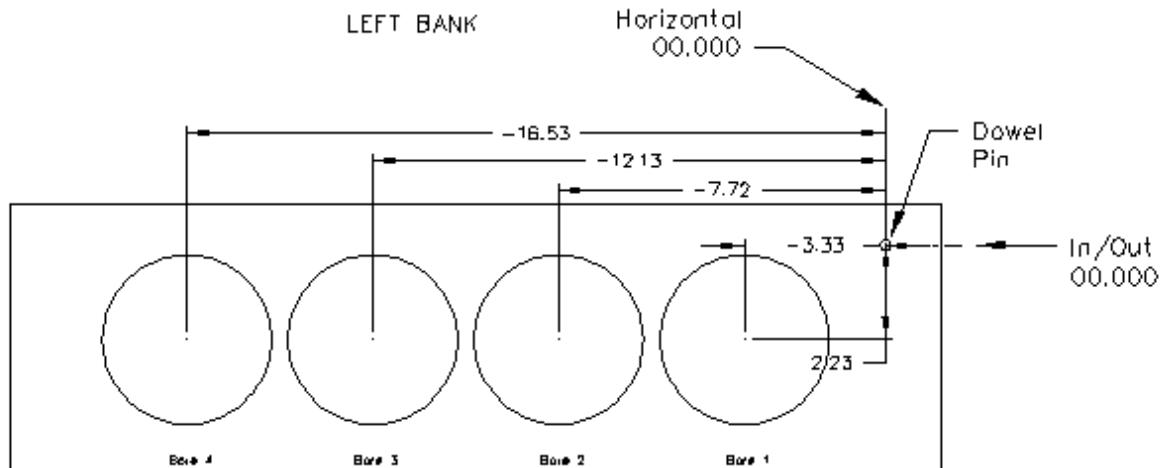

Select Left Locations and then Indicated. If you have programmed the blueprint locations into this program then press Copy Values and then Blueprint. This will cause the values from the Blueprint page to be copied into the Indicated page. This give you a starting point to indicate the individual cylinder from.

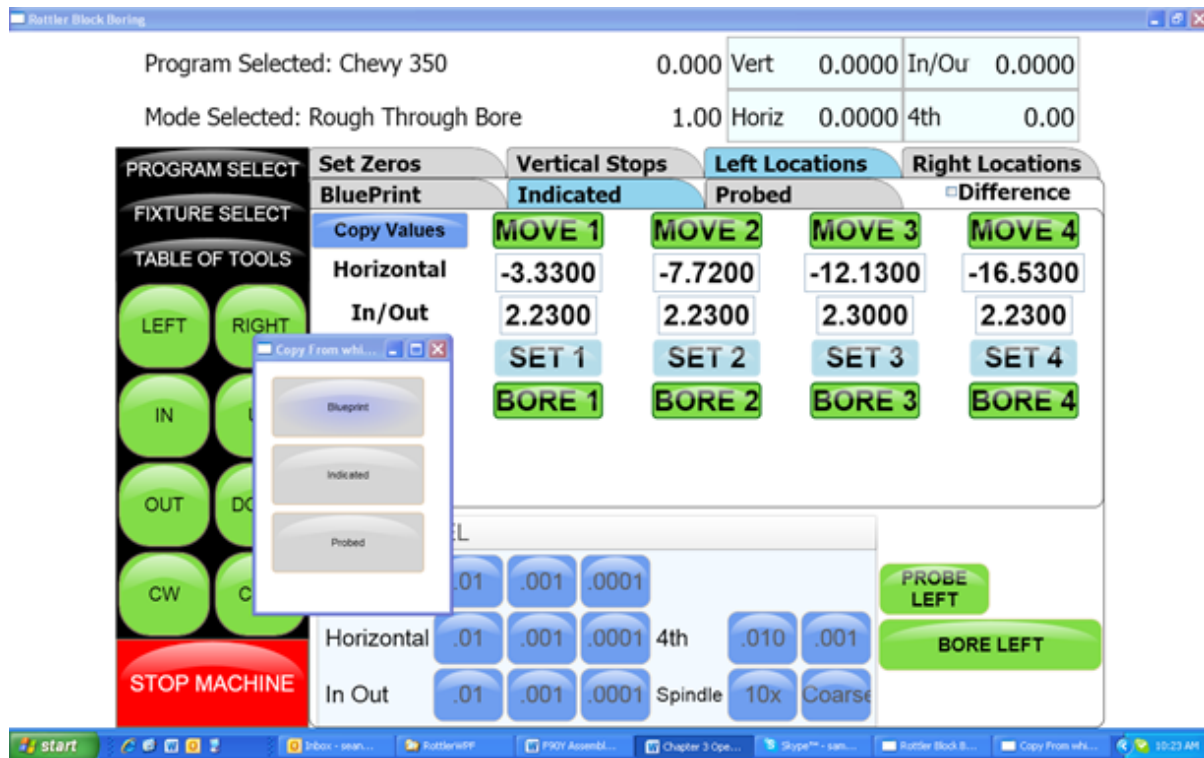

Press the Move 1 button. The machine will move to the first cylinder and stop at the centering position. Manually indicate the cylinder in using the Horizontal and In/Out handwheel. Once the cylinder is centered press the Set 1 button. This will transfer the current position of the machine into the first set of Data Boxes. Repeat this process for all the cylinders that need to be indicated. Press the Right Locations tab and repeat the above procedure for the cylinders to be indicated on the right bank.

## Boring a Block

Once the Vertical, Horizontal and In/Out stops have all been entered the Spindle RPM and Feed Rate need to be entered. This is done on the Set Zeros screen. Once this is done you can go to the Left and/ or Right Bore location screens and bore the cylinders.

Pressing the Bore Left for Bore Right buttons Will Bore all the cylinders that have Green bore button below them.

Pressing a Bore button once will turn that button Yellow. Any Yellow button will not be bored when the Bore Left or Right button is pressed.

Double clicking any Bore button will turn all the Bore button yellow EXCEPT the one that was double click.

## Probing

Even if you are not going to be boring a block to the blue print specifications it is still recommended to have these values entered. It will speed up the process of indicating and probing a block by giving the operator a close estimate of bore location.

### Vertical Zero

There are three different ways to use the boring software, Blueprinting, Indicating and Probing. It is not unusual for all three modes to be used on the same size block. The vertical stops for these different operating programs will vary. Be sure the vertical stops are set correctly for the mode you are using. For this example the deck will be our zero for the Vertical axis. Insert a tool holder into the cutterhead you will be using to bore the block. Center the cutterhead over a cylinder. Using the Vertical Handwheel, bring the cutterhead down until the tool just touches the deck and press the Vertical Zero button. The display above this button will go to zero. The Vertical zero has now been set.

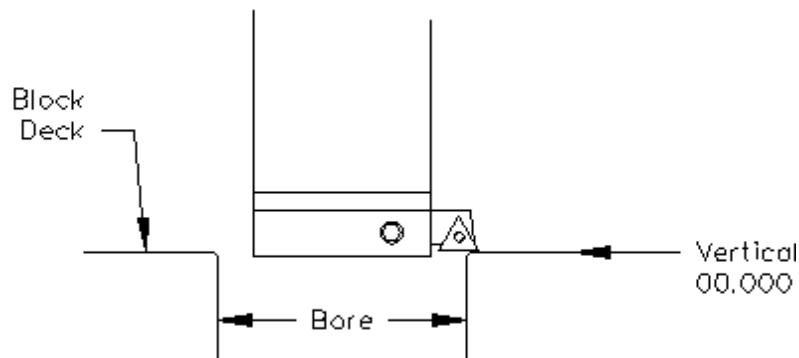

The zeros points for all axis have now been set. All the numbers entered from this point on will reference these zero positions. You are finished with the Set Zeros screen, select the next Tab to the Right.

## Programming Vertical Stops

To build a program you must set the Vertical Stops for the program.

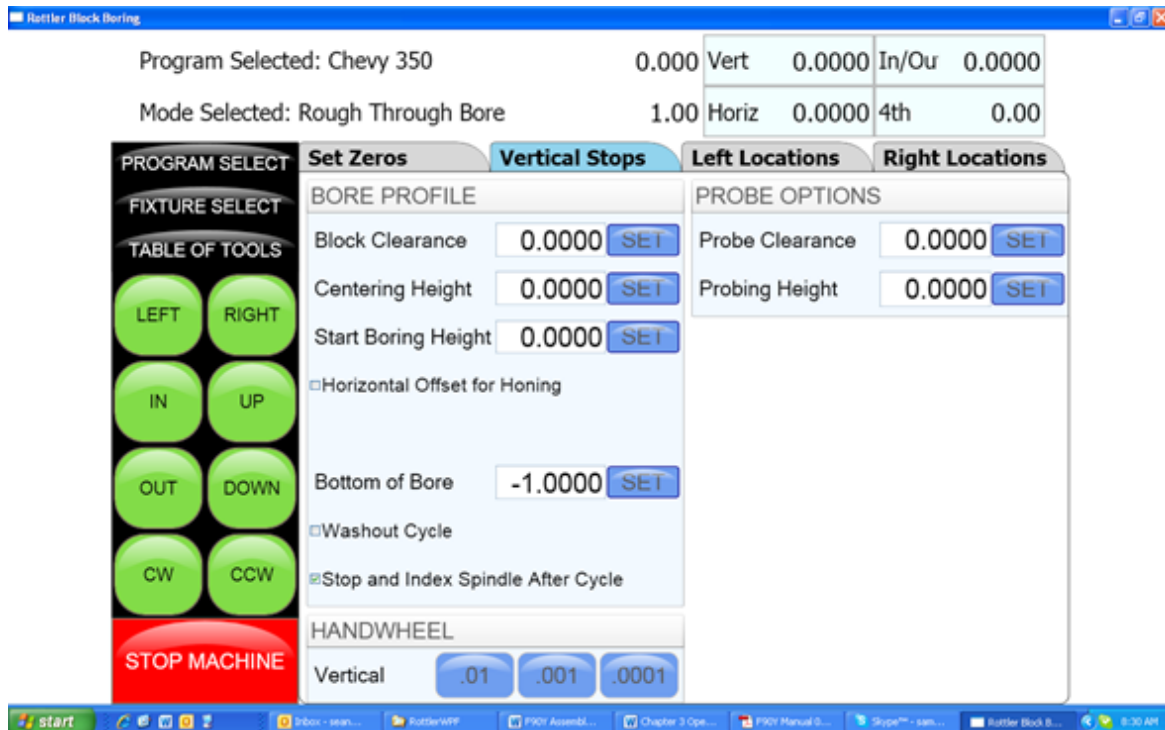

### Block Clearance

This is the distance above the zero position or block deck allowing the probe to move to the next bore unobstructed.

### Centering Height

This stop is not used when you are using the probing feature. It is recommended that it be set to the same value as the Block Clearance.

### Start Boring Height

This is the distance above zero or the block deck where you want the cutterhead to start rotating and the downward feed to start. Generally this is just a short distance above the block deck to minimize the amount of time the machine bores through air.

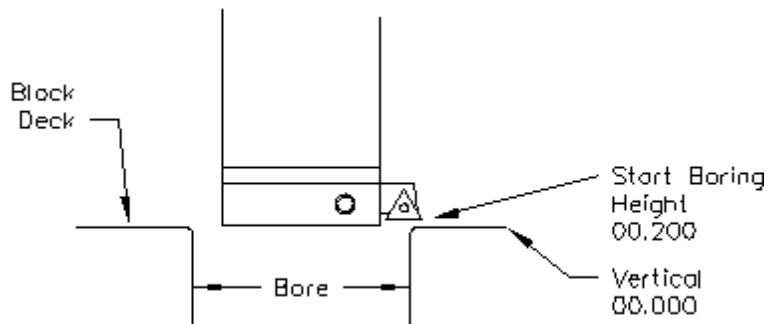

## Bottom of the Bore

This is the distance below zero or the Block deck where you want the machine to stop boring and retract out of the cylinder. When the spindle retracts it will then go to the block Clearance position. This is an example of what the above program would look like on the vertical stops.

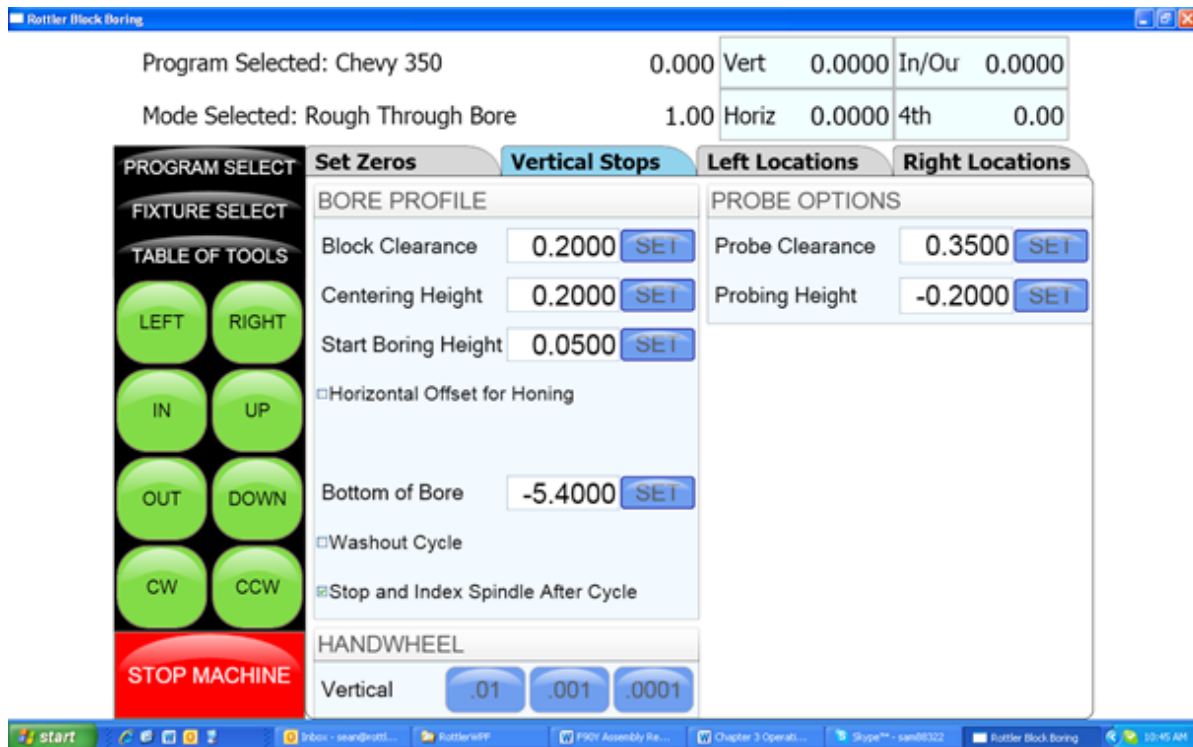

## Probe Height

When using the optional Probe... install the probe into the spindle after your vertical positions have been set using the cutterhead.

Using the handwheel and bring the Probe down to the location in the cylinder you will be probing. Press the SET button next to Probe height. This will set the probing height position.

Using the handwheel move the probe up until it can safely move horizontal to the next cylinder. Press the SET button next to Probe Clearance. This will set the clearance height.

The Vertical stops have now been set. You are finished with the Vertical Stops screen, select Left and/or Right Locations.



## Bore Locations

To build a program you must set the Horizontal and In/Out Stops for the program All Horizontal and In/Out stop are based from where their zero positions were set.

Select Left Locations and the Blueprint. Program the blueprint values (or close approximation) into the Horizontal and In/Out stops. Do the same for the Right Locations.

Select Left Locations and then Probing. You can probe each cylinder individual by pressing the associated Probe button or you can probe the entire bank by pressing the Probe Left Button. This is the same procedure for the Right Bank.

## Probe Auto Center

This feature is located on the Set Zero page. This allows easily find the center of a hole or cylinder.

Roughly place the probe in the center of a cylinder. Press Probe Auto Center. The cylinder will be probed in 4 places, when finished the probe will move to the center of the probed cylinder. Pressing Horizontal and In/Out zero will then establish the center of that hole.

## Automatic Probing Procedure

The probe will move to the center of the cylinder to be probed. It will then move to the right at a slow rate until the side of the cylinder is touched, it will then back off slightly and touch the same spot again to confirm position. The probe will then touch off the cylinder in three more spots and retract from cylinder. As each cylinder is probed the Probed Diameter, Horizontal and In/Out positions will be placed into the Data Boxes for the corresponding cylinder.

Press the Right Locations tab and repeat the above procedure for the cylinders to be probed on the right bank.

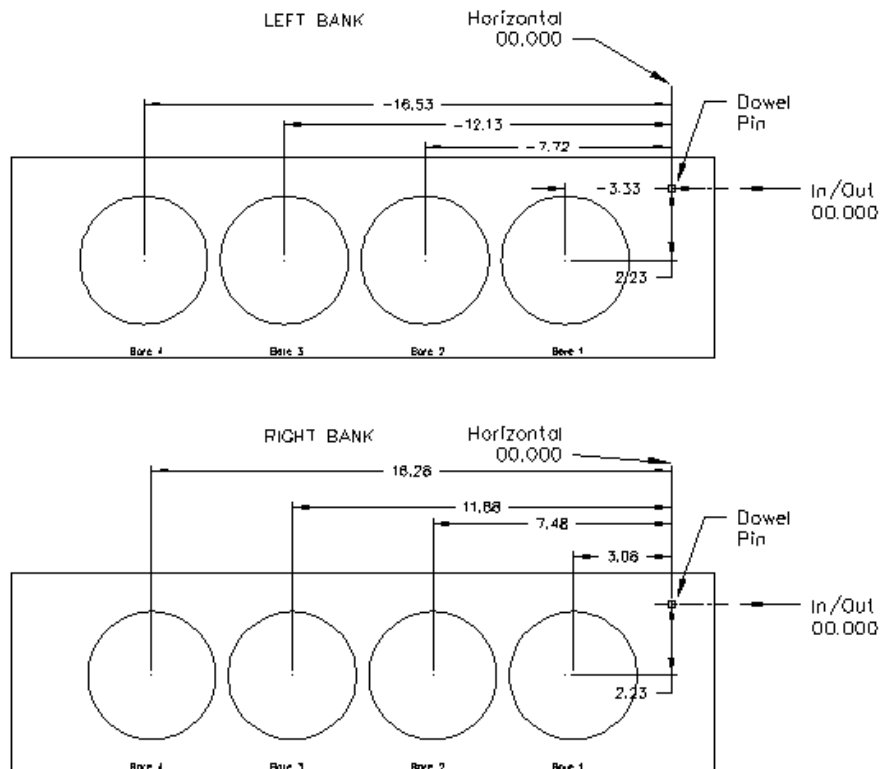

The Horizontal and In/Out stops have now been set.

## Boring a Block

Once the Vertical, Horizontal and In/Out stops have all been entered the Spindle RPM and Feed Rate need to be entered. This is done on the Set Zeros screen. Once this is done you can go to the Left and/or Right Bore location screens and bore the cylinders.

Pressing the Bore Left for Bore Right buttons Will Bore all the cylinders that have Green bore button below them.

Pressing a Bore button once will turn that button Yellow. Any Yellow button will not be bored when the Bore Left or Right button is pressed.

Double clicking any Bore button will turn all the Bore button yellow EXCEPT the one that was double click.

## Cylinder Bore Mode 4th Axis

**NOTE: The program with the 4th axis installed works basically the same as the 3 axis mode. ONLY the differences in operation and screens will be discussed here. Carefully read through the 3 Axis mode and then the 4th axis mode for operation and building programs.**

Select Cylinder Bore and then Through Bore on the control panel. This will bring up the boring program with the Set Zeros tab shown.

### Setting Zeros

The purpose of setting zero points is to give the operator a specific point to build programs from. The machine also uses these zero points to run the program from. The zero points can be set at any point in the machines' travel. Each axis (except the Spindle rotation) will need to have a zero point set for the machine to operate from.

### 4th Axis (Rotational) Zero

The Zero position for the 4th (Rotational) Axis should be preset from the factory. If the zero needs to be reset use the following procedure.

There are three (3) flats cut onto the Head Stock Plate. Use the middle flat to set the rotational zero.

Using an indicator off of the spindle indicate the middle flat to Zero all the way along it. Use the 4th Axis hand wheel to do this. When the middle flat is indicated in press the 4th Axis Zero button. You 4th (Rotational) Zero is set.

### Finding the In/Out (Y) Axis Zero with 4th Axis

The Head Stock Plate has a hole in it next to the Middle Flat. This hole is centered on the center of the Main and Cam locator shafts.

### Building Programs with the 4th Axis

Program are built the same as in the 3 Axis mode with the exception of setting the Angle for each Bank. The Left and the Right Locations page each have an Angle Data Box. Here you enter the angle of each bank from the 4th Axis (Rotational) zero position. The zero position is with the Cam and Crank Locators lined up vertically.

**Example: On a Chevy 350 the Left bank would be positive 45 Degrees and the Right Bank would be a negative -45 Degrees.**

## Setting Vertical Clearance with 4th Axis

It is very important when setting your Vertical and Probe Clearance height that you be sure to account for the Roll Over of the block from bank to bank. When in an automatic program the block will roll from the Left Bank to the Right bank at the Left Bank Bore1 position. It will also rotate from the Bore1 position when going from Right Bank to Left.

## Table of Tools for 3 and 4th Axis Bore Mode

**NOTE: The Table of Tools is not needed to run the Rottler automatic programs. It is recommended that it not be used except by the advanced operator.**

## Building a Program with Table of Tools

Build the program as described above for 3 and 4 Axis programs using the same vertical zero locations. Put the tools to be used into the Table of Tools as described in Chapter 2. In Bore mode you are not referencing another vertical location such as the Crank centerline so the Z Touch off Location will remain at zero.

## Assigning Tools

Tools to be used in the boring operations are set on the Set Zeros page. To select a Tool, double click on Tool # on the right side of the screen. This will bring up the Table of Tools window. Highlight the tool you will be using, such as 2.9 Production Stub and select OK.

Do the Same to select the Probe you will be using, such as 100mm Probe.

**NOTE: The Tool highlighted in red is the currently Active tool.**



The following shows what the screen will look like with two tools assigned but none of them active. Default Tool 0 is set active and only shows on the Table of Tools screen.

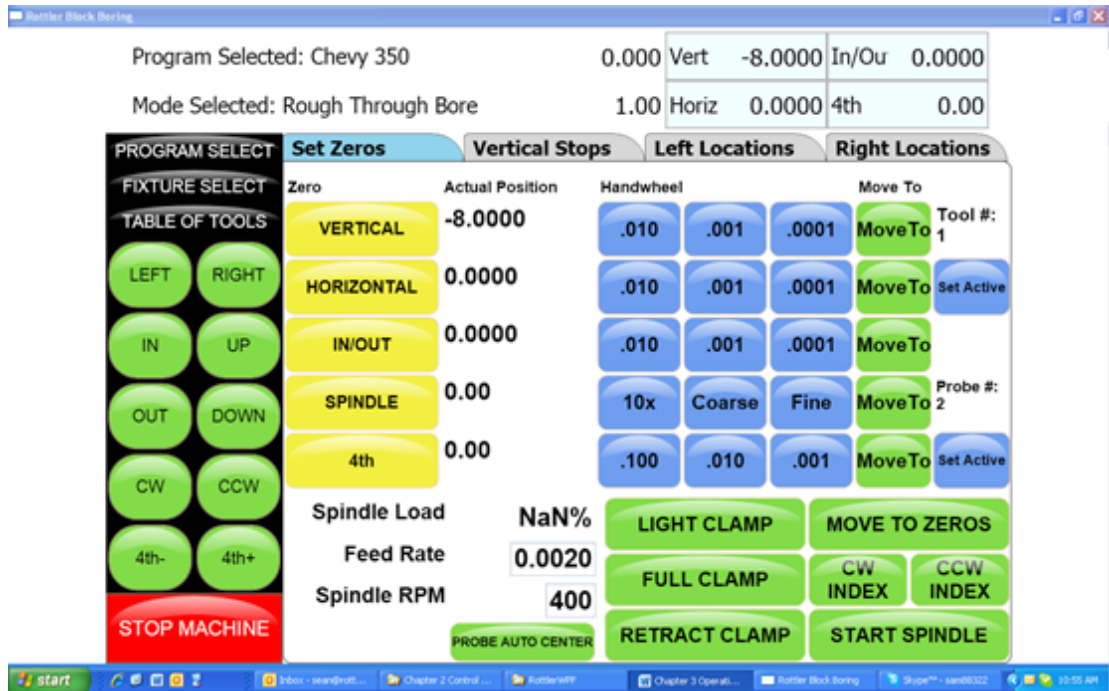

### Setting Tools Active

Physically install the first tool you will be using in the program. For this example physically install the 100mm Probe into the spindle. Press the Set Active button below the Probe #. The Tool Change Form will Open. This is to vary your Vertical Tool Length and Probe Diameter. Select OK and then OK again on the spindle warning page.

**IMPORTANT:** The Tool Diameter on this page is used for the Probe. This must be set to the actual Diameter of the probe when probing cylinders. The Tool Diameter is NOT used for Boring Bars, End Mills etc... in the Rottler Bore program.



The Currently Active tool in a program will be highlighted in Pink on the Set Zero page.



If you attempt to run the Probing Cycle with the Tool # active the machine will automatically move to the Tool Change clearance position and open the Tool Change Window so you can change the tool and vice versa.

## Mill Mode 3 Axis

### Setting Zeros

The purpose of setting zero points is to give the operator a specific point to build programs from. The machine also uses these zero points to run the program from. The zero points can be set at any point in the machines' travel. Each axis will need to have a zero point set for the machine to operate from.



### Horizontal Zero

For this example we are going to set the Horizontal Zero approximately 1/4" from the right hand side of the work piece.

### In/Out Zero

For this example we are going to set the In/Out Zero at the center line of the work piece.

### Vertical Zero

For this example the Vertical Zero will be at the deck height of the work piece.

### Example

Install the Milling cutterhead you will be using into the machine. Move the In/Out axis and center the work piece under the spindle. Press the In/Out Zero button here. Move the Horizontal Axis to that the cutter is overhanging the work piece about 1/4". Bring the Vertical Axis down until the cutter is just above the work piece. At this time it should look similar to the drawing below.



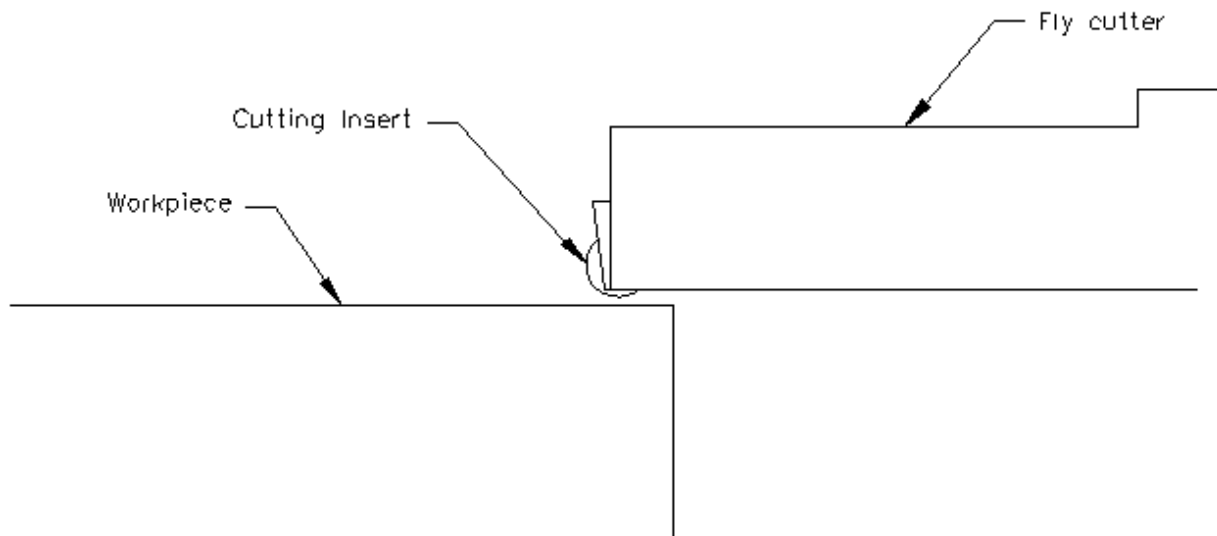

Set the Spindle RPM and Feed rate on this screen.

Start the spindle. Press the Vert .001 button to put the handwheel in .001 per detent. Slowly move the spindle downward until you can hear or see the cutter just touch the block. Press your Vertical Zero button here. Press the Right travel button to feed the spindle off of the work piece. When the cutter has cleared the work piece press the Right travel button again to stop the feeding. Press the Horizontal Zero here.

Your zero position for all axis have now been set.

## Mill Operation

**IMPORTANT:** Do not move the machine In/Out with the Wedge on. The Wedge comes on automatically when the Mill program is entered. If you need to move the machine In/Out to center on the work Piece use the turn Wedge On/Off button at the bottom of the page to do so. Make sure the Wedge is back on when you start the cycle.

This screen is used to set certain parameters the F107/9AHL will use to run the automatic cycle.

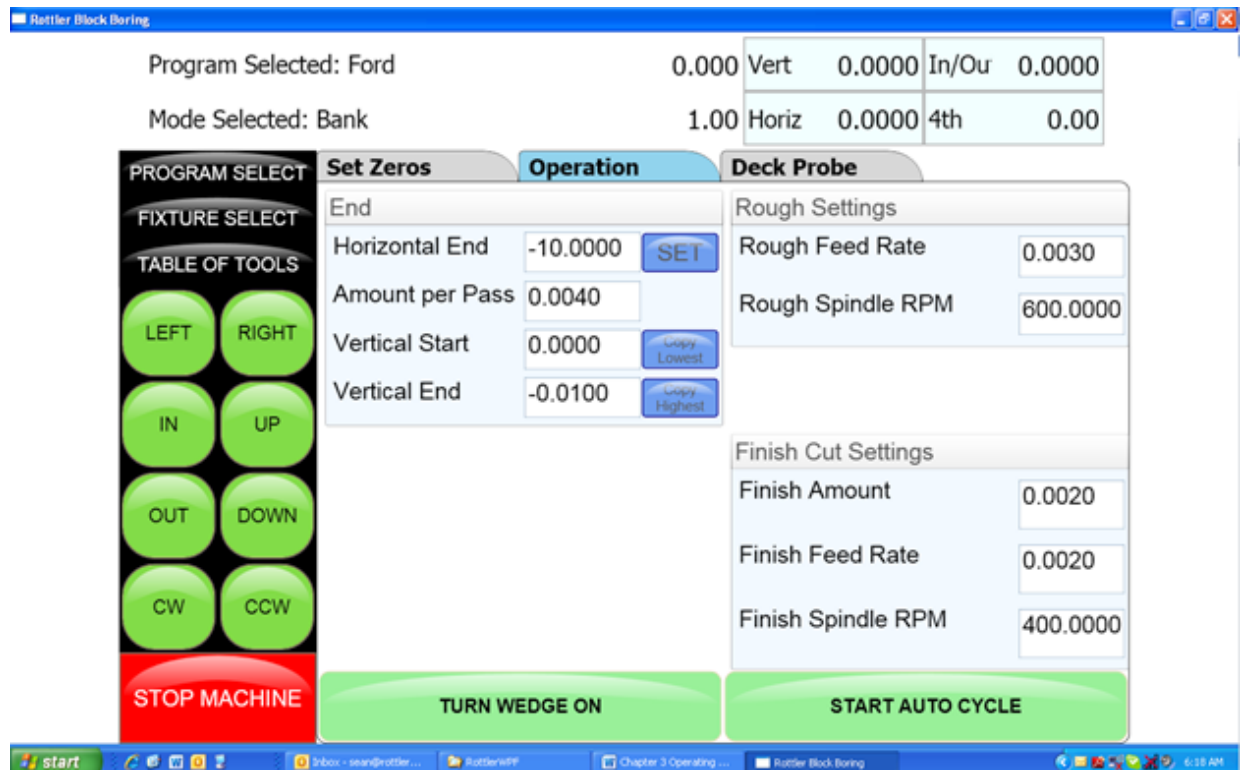

## End

### Horizontal End

This displays the current end stop value. To enter a new value press the display and a pop-up numerical key pad will appear. Press the desired end stop value and then ENTER. This is the distance from where the Horizontal Zero was set. You can move the fly cutter manually to the end of the cut and press the SET button. This will automatically put the Horizontal End value in for you.

### Amount Per Pass

This is the amount of material removed from the work piece on each pass of the cutterhead.

### Vertical Start

This is the Vertical Position the machine will start cutting at. This value is usually Zero which is usually the starting Deck Height.

### Vertical End

This is the Vertical Position the machine will stop cutting at. It is the Total amount of material you want to remove in the Milling process.



### Copy Lowest Copy Highest

These buttons will be discussed in the Mill Probing section of this Chapter.

### Rough Settings

These values are used when taking multiple passes on a work piece. These values can be set high to remove material quickly. The finish on the work piece does not matter in these settings. There will be a Final pass that will apply the finish to the work piece.

#### Rough Feed Rate

Enter the desired Roughing Feed Rate;

#### Rough Spindle RPM

Enter the Desired Roughing Spindle RPM.

#### Finish Cut Settings

These values will be used for the last pass the machine will make on the work piece. These will determine the finish left on the work piece.

#### Finish Amount

Enter the amount to be removed on the last pass.

#### Finish Feed Rate

Enter the desired Finish Feed Rate.

#### Finish RPM

Enter the desired Finish Spindle RPM.

**NOTE: You do not need to have evenly divisible numbers in these sections. The computer will do the math to remove the correct amount each time and for the final pass to be at the amount you set.**

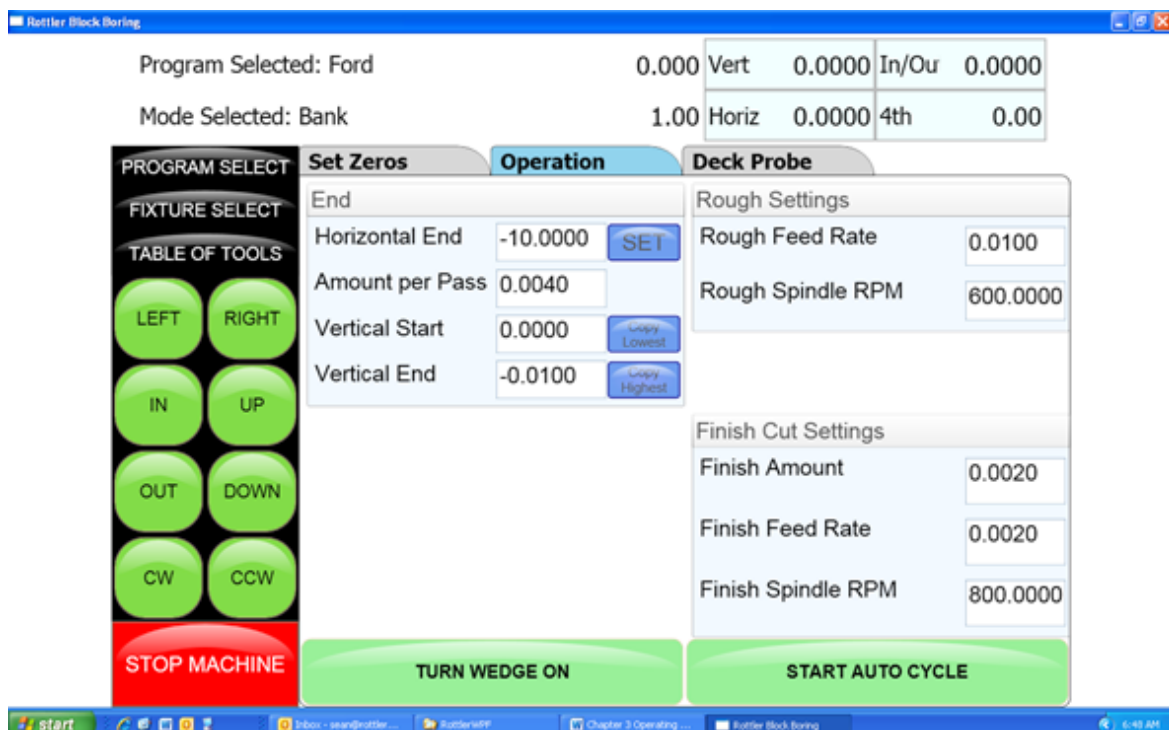

## Start Auto Cycle

Pressing this button will start the machines automatic cycle. The cycle to be run is determined by the setting on this page. If you only require one pass to be made, do not enter any values into the Rough Setting, only the Finish Cut Settings.

## Mill Mode 4th Axis

### Setting Zeros

The purpose of setting zero points is to give the operator a specific point to build programs from. The machine also uses these zero points to run the program from. The zero points can be set at any point in the machines' travel. Each axis will need to have a zero point set for the machine to operate from.

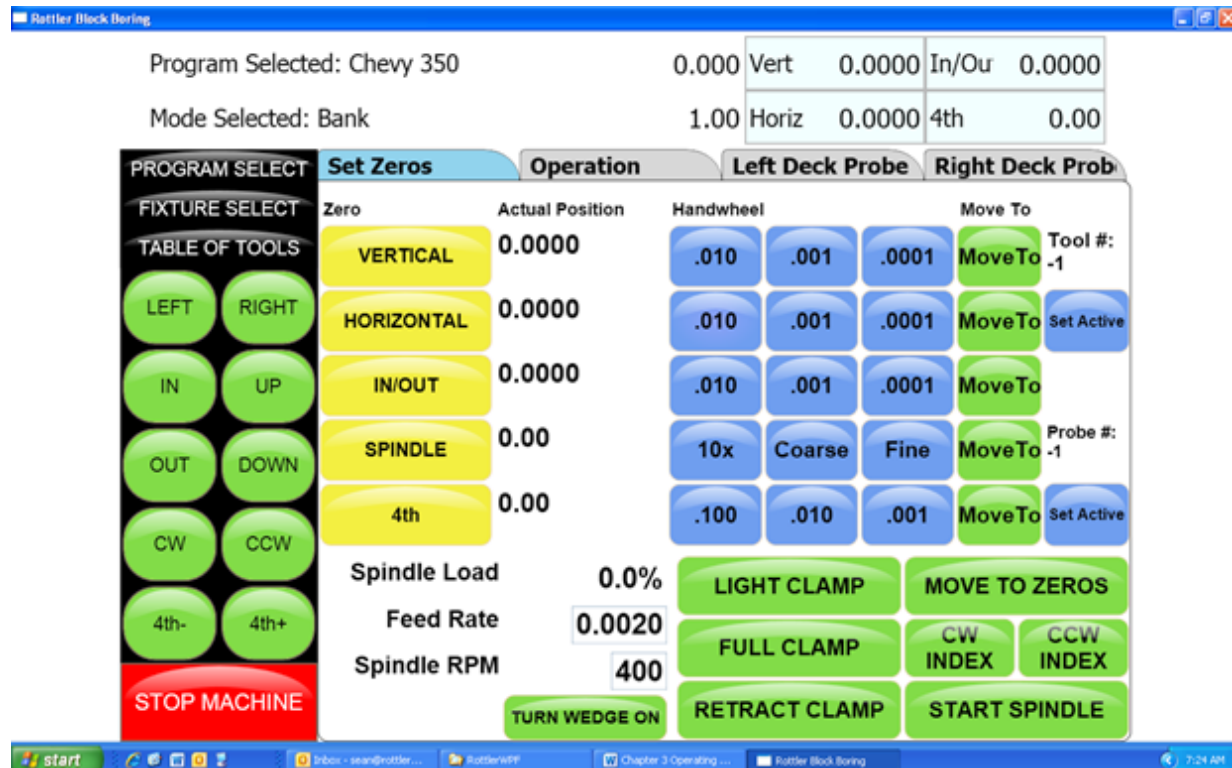

### Horizontal Zero

For this example we are going to set the Horizontal Zero approximately  $\frac{1}{4}$ " from the right hand side of the work piece.

### In/Out Zero

For this example we are going to set the In/Out Zero at the center line of the work piece.

### Vertical Zero

For this example the Vertical Zero will be at the deck height of the work piece.

When setting the vertical zero it is important to check the deck height on both banks of the block before starting a cycle. It is possible that the right bank may be higher than the left bank where the vertical zero was set. This would cause a crash when the block rotated and the cycle was started on the right side.

**CAUTION**

**Example:**

Install the Milling cutterhead you will be using into the machine. Move the In/Out axis and center the work piece under the spindle. Press the In/Out Zero button here. Move the Horizontal Axis to that the cutter is overhanging the work piece about  $\frac{1}{4}$ ". Bring the Vertical Axis down until the cutter is just above the work piece. At this time it should look similar to the drawing below.

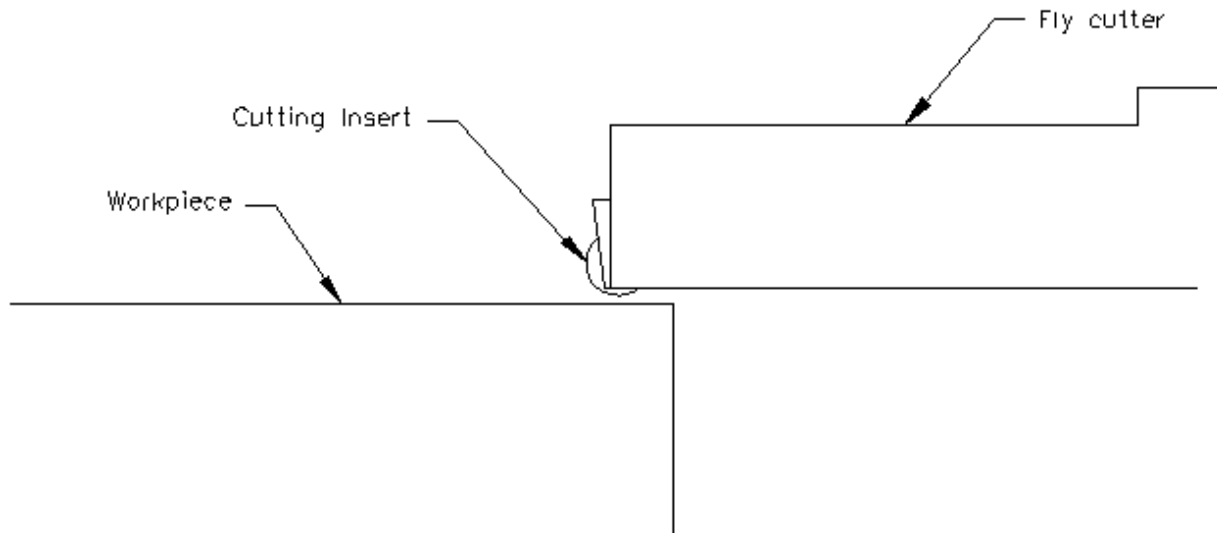

Set the Spindle RPM and Feed rate on this screen.

Start the spindle. Press the Vert .001 button to put the handwheel in .001 per detent. Slowly move the spindle downward until you can hear or see the cutter just touch the block. Press your Vertical Zero button here. Press the Right travel button to feed the spindle off of the work piece. When the cutter has cleared the work piece press the Right travel button again to stop the feeding. Press the Horizontal Zero here.

Your zero position for all axis have now been set.

## Mill Operation

**IMPORTANT:** Do not move the machine In/Out with the Wedge on. The Wedge comes on automatically when the Mill program is entered. If you need to move the machine In/Out to center on the work Piece use the turn Wedge On/Off button at the bottom of the page to do so. Make sure the Wedge is back on when you start the cycle.

This screen is used to set certain parameters the F103/4/5A will use to run the automatic cycle.

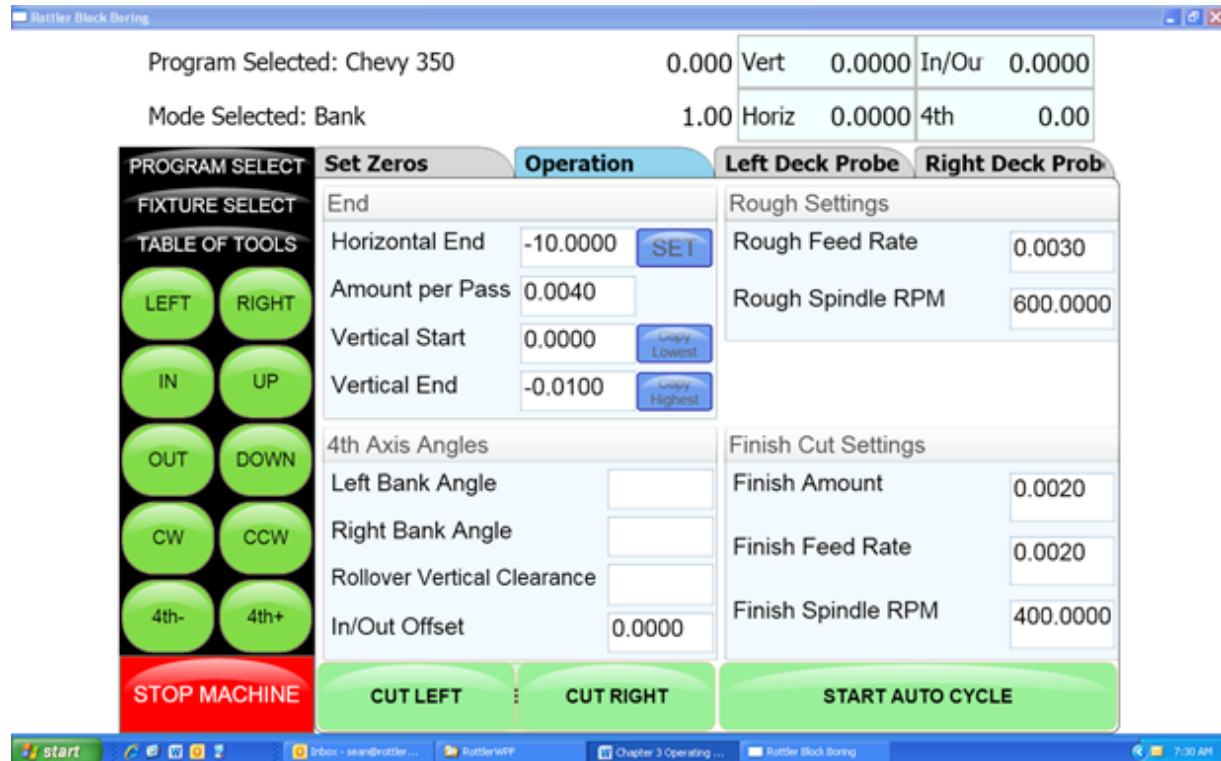

## End

### Horizontal End

This displays the current end stop value. To enter a new value press the display and a pop-up numerical key pad will appear. Press the desired end stop value and then ENTER. This is the distance from where the Horizontal Zero was set. You can move the fly cutter manually to the end of the cut and press the SET button. This will automatically put the Horizontal End value in for you.

### Amount Per Pass

This is the amount of material removed from the work piece on each pass of the cutterhead.

### Vertical Start

This is the Vertical Position the machine will start cutting at. This value is usually Zero which is usually the starting Deck Height.

### Vertical End

This is the Vertical Position the machine will stop cutting at. It is the Total amount of material you want to remove in the Milling process.

**Copy Lowest Copy Highest**

These buttons will be discussed in the Mill Probing section of this Chapter.

**4th Axis Angles****Left Bank Angle**

Enter the angle of the Left Deck. This is the angle of the block in reference to the Cam and Crank bore being lined up Vertically.

**Right Bank Angle**

Enter the angle of the Right Deck. This is the angle of the block in reference to the Cam and Crank bore being lined up Vertically.

**Rollover Vertical Clearance**

Enter the value the Fly Cutter will have to move up vertically to clear the block when it rolls over from bank to bank.

**In/Out Offset**

This is a value that can be entered to center the fly cutter in the middle of the deck. You In/Out center on the Left bank will not be the center of the In/out on the Right bank. Enter the value the In/Out will need to be moved to center on the Right Bank when it rolls over.

**Rough Settings**

These values are used when taking multiple passes on a work piece. These values can be set high to remove material quickly. The finish on the work piece does not matter in these settings. There will be a Final pass that will apply the finish to the work piece.

**Rough Feed Rate**

Enter the desired Roughing Feed Rate;

**Rough Spindle RPM**

Enter the Desired Roughing Spindle RPM.

**Finish Cut Settings**

These values will be used for the last pass the machine will make on the work piece. These will determine the finish left on the work piece.

**Finish Amount**

Enter the amount to be removed on the last pass.

**Finish Feed Rate**

Enter the desired Finish Feed Rate.

**Finish RPM**

Enter the desired Finish Spindle RPM.

**NOTE: You do not need to have evenly divisible numbers in these sections. The computer will do the math to remove the correct amount each time and for the final pass to be at the amount you set.**

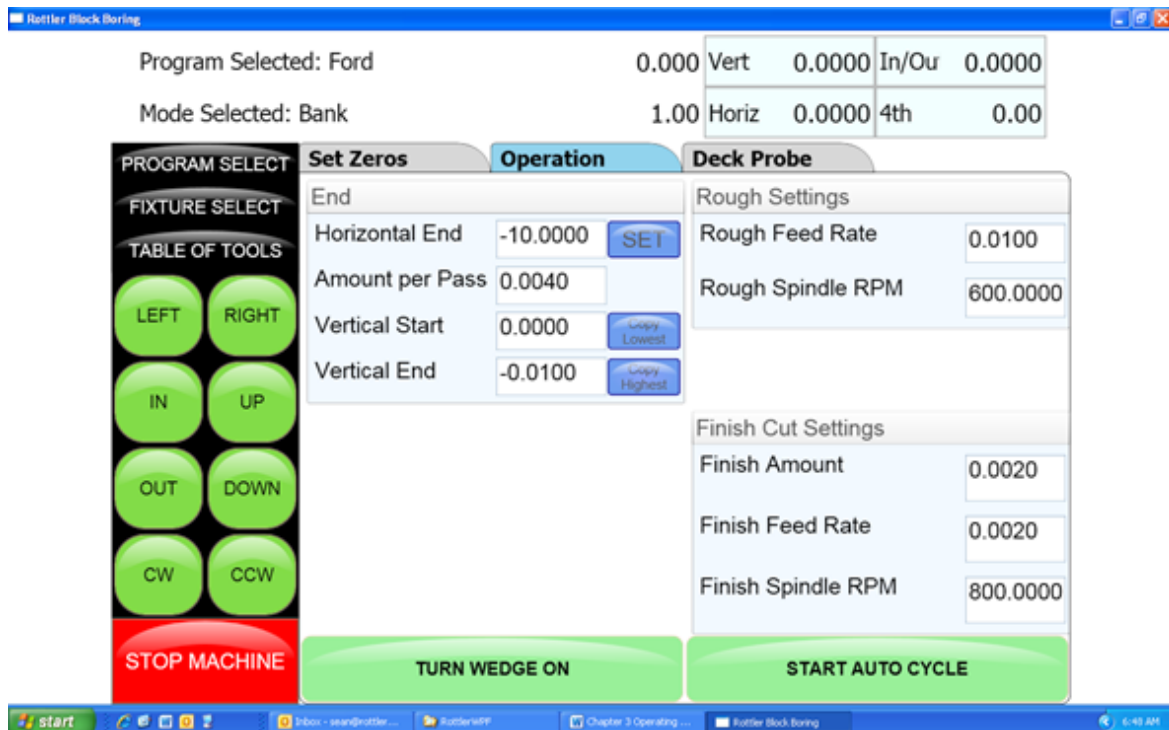

### Cut Left and Cut Right

Pressing these buttons will cause the machine to run an automatic cycle (per the parameter defined in the Operations page) on the associated bank.

### Start Auto Cycle

Pressing this button will start the machines automatic cycle. The cycle to be run is determined by the setting on this page. If you only require one pass to be made, do not enter any values into the Rough Setting, only the Finish Cut Settings.

## Milling Using Automatic Deck Probing

The Rottler Milling program is set up to Automatically Probe the Deck height of a block and then Mill it to a set Deck Height. This can be done on a 3 or 4 axis machine.

### Table of Tools for Milling

You MUST use the Table of Tools if you want to Automatically Probe the deck height and cut it to a set height.

Once done the Table of Tools Should look similar to the below picture.



The 100mm Probe is Tool 1. The 10" Fly Cutter is Tool 2.

Go to Program Select, then select the block you are working with and then Mill Mode.

Install the Probe physically into the spindle. Rotate the 4th axis to Zero degrees. Indicate the Middle flat on the head stock to be sure it is zero all the way across. There should be a number stamped into the headstock. This is the distance from the Flat to the center of the Crank. Bring the probe down until it just touches the middle flat.

Open the Table of Tools and double click on Tool1 100 mm Probe. Enter the Measured diameter of your Probe. This is not used in the Milling Program but needs to be entered accurately for Probing in the Bore mode.

On the open window select Get Length. This will open another Window. There will be a value, that you cannot edit, in the "Z Location from Zero" this is the distance the Vertical Axis is from home when the Probe touches the Middle flat.

In the Data box for "Z Touch off Height" enter the number that is stamped on the Head Stock. This is the distance from the flat to the center line of the Crank.

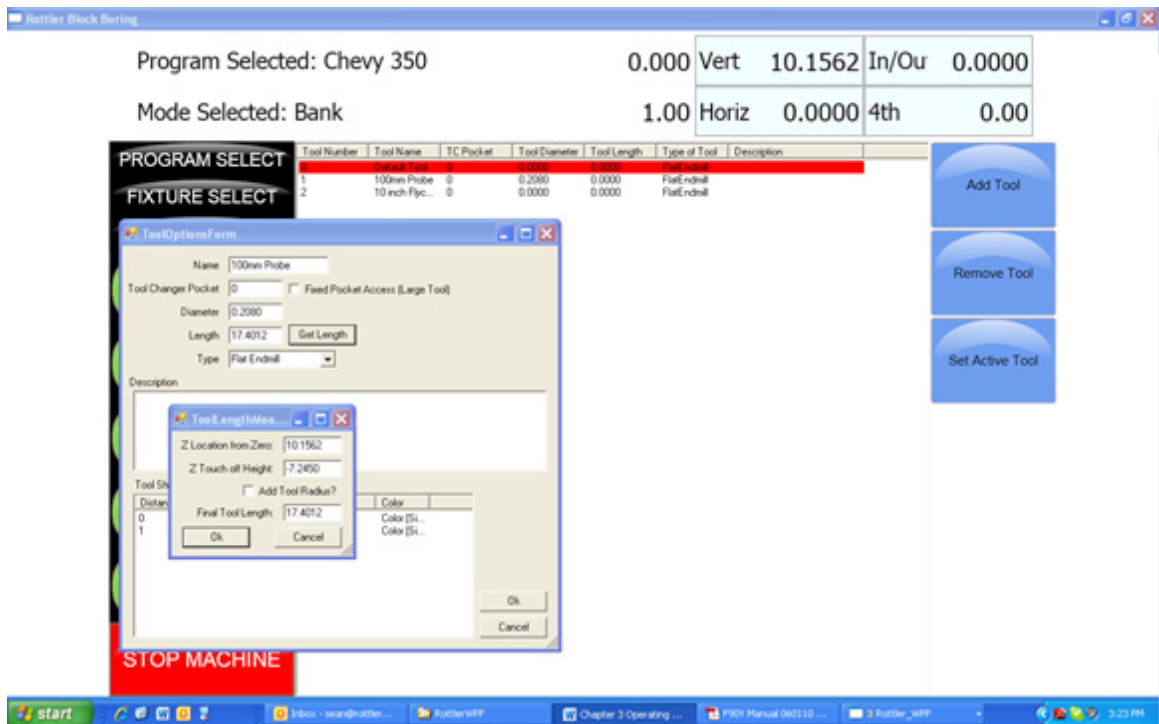

Select OK on both windows. This will put the Total tool length into the Table of Tools.

The Vertical Digital Read Out will now consider the center of the Crank bore to be the Vertical Zero position.

When the Probe tip or Cutting insert touches the Deck the Vertical DRO will be reading out the distance from the center of the Crank bore (Actual Deck Height).



### Assigning Tools

From the Set Zero Tab, select Probe#. This will open the Tools Select Form. Select Tool 1, 100 mm Probe and click OK.

Select the Tool#. This will open The Tool Select Form. Select Tool 2, 10 inch Fly Cutter and click OK. The tools to be used have now been assigned to the program.

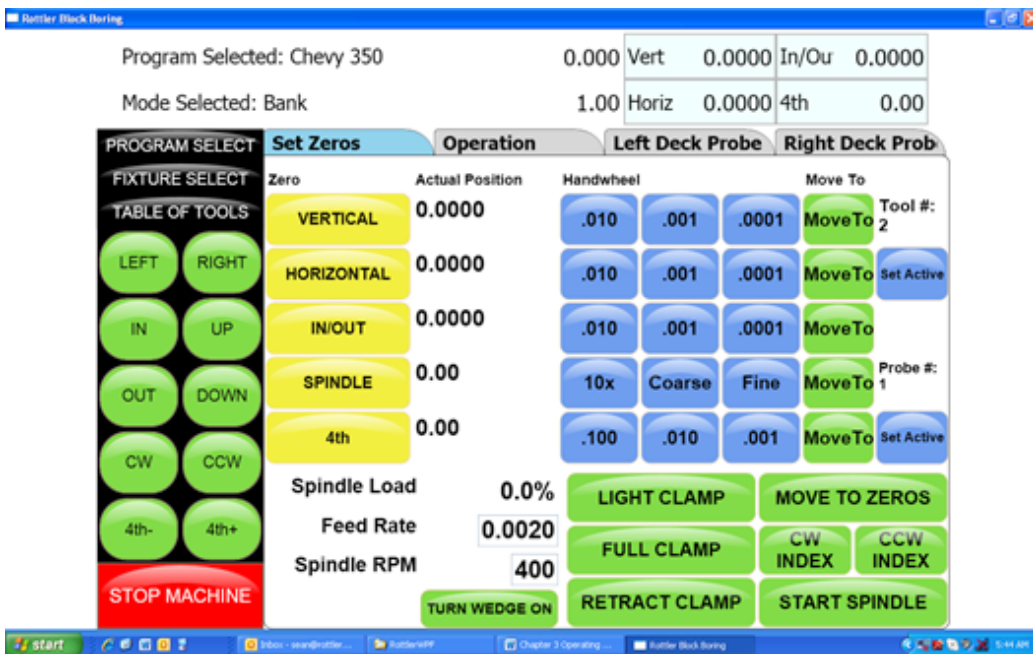
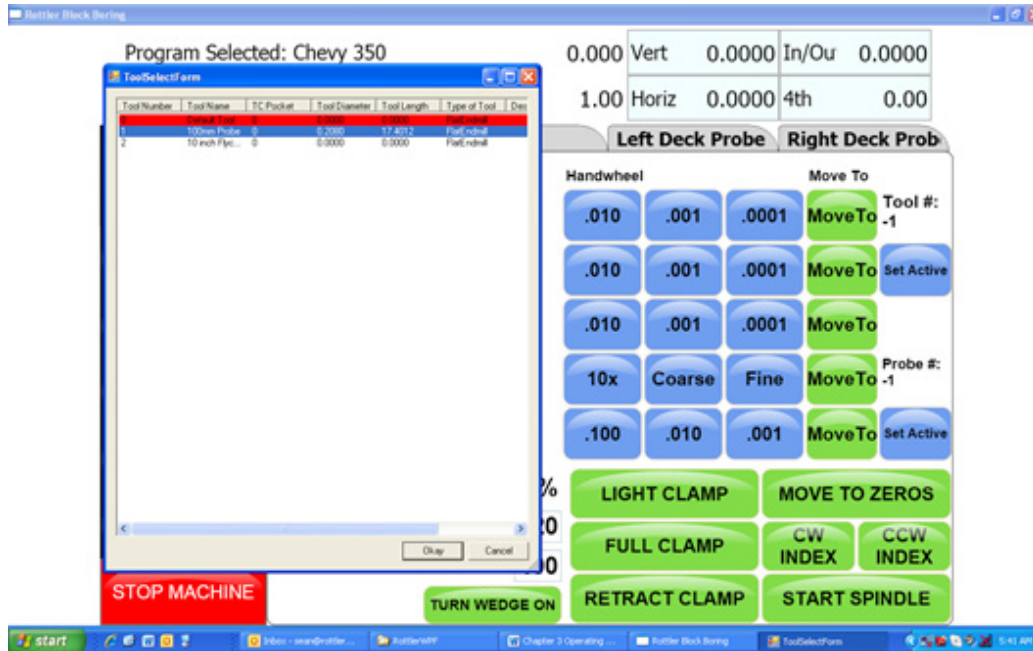

## Setting Tools Active

To set a Tool Active (tool to be used) Press the Set Active button below that tool. Set the Probe Active. This will bring up the Tool Change Form. Here you can verify the information for the tool. Select OK. Select OK on the Spindle warning form if it appears.

The Probe# will now be highlighted in Pink, this indicates that the tool is active (being used). If you were to open the Table of Tools at this point, Tool 1 will be highlighted in Red. This also indicates that Tool 1 is active.

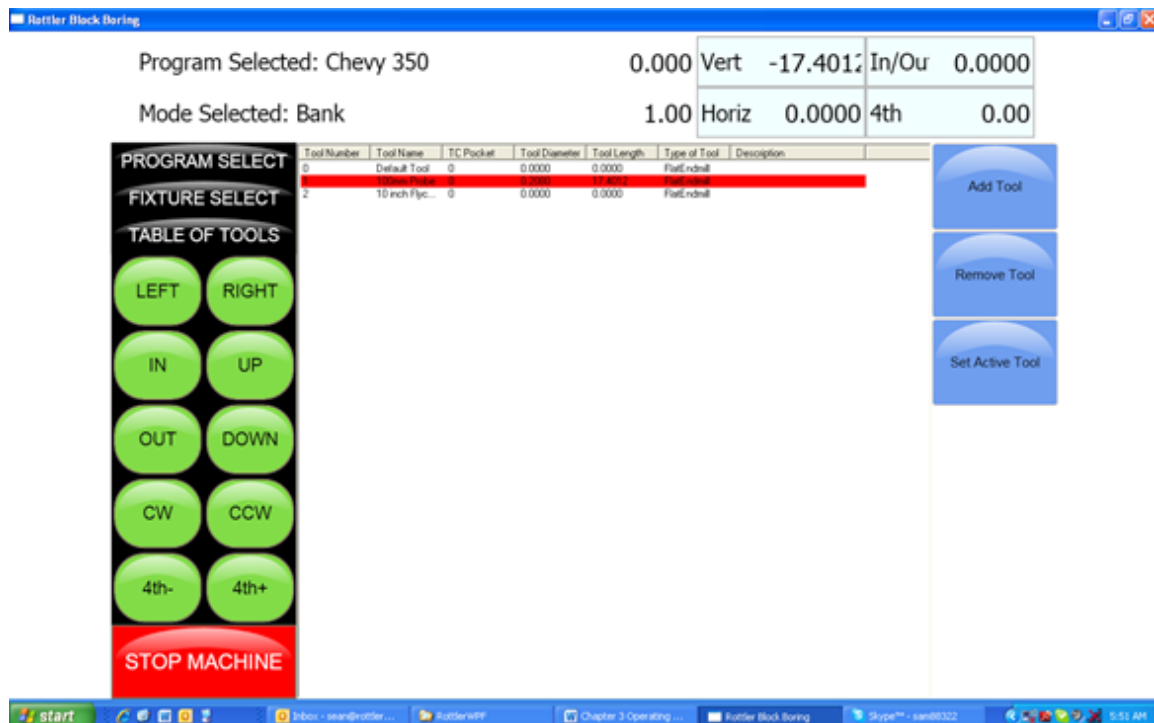

## Building a Program Using Table of Tools

Enter all the values that were described in 3 and 4 Axis Milling earlier in the chapter.

Physically install the probe into the spindle and set active. Bring the probe down until it just touches the Deck. Look at the value in the Vertical DRO. This is the current deck height at position. Enter that numeric value into the Vertical Start. This gives the Probe a value to start probing the deck at.

### Left Deck Probe

Enter the positions you want the Probe to probe here. You can physically move the probe to the locations on the bank you want to probe and hit the set button also.

### Right Deck Probe

Roll the block over to the Right Bank. Enter the positions you want the Probe to probe here. You can physically move the probe to the locations on the bank you want to probe and hit the set button also.



### Auto Probing

Press the Start Probing button. The machine will first probe each programmed location on the left bank and record the height. The spindle will move to Vertical Clearance height and the block will roll over to the right bank and probe the programmed locations and record them. The block will then roll back over to the Left bank and the spindle will move to the first Left location and stop.

**Auto Milling**

Go to the Operations Tab.

**Vertical Start**

Press Copy Highest next to Vertical Start. This will copy the Highest Probed point of either bank. This is the Height at which the Start Auto Cycle would start the first cutting pass.

**Vertical End**

Press Copy Highest next to Vertical Start. This will copy the Highest Probed point of either bank. This is the height at which the Start Auto Cycle would end the Final Pass. You would use this value if you just wanted to clean the deck up to the lowest point. If you want to cut the Deck Height to a certain value you would manually enter that value into the Vertical End Data Box.

**Cut Left or Cut Right**

Pressing either of these buttons will Start the Auto Cycle for only the associated bank. That bank will be cut to the set parameters and the machine will stop.

**Start Auto Cycle**

Pressing this button will start the Auto Cycle for Both Banks. First the Left bank will be cut to the set parameters. The spindle will go to the Clearance Height and Roll over to the Right bank and cut it to the set parameters. The Spindle will again go to the Clearance Height and roll over to the Left bank. The machine will go idle at this point.

### Lifter Bore Mode 3 Axis

Lifter Bore programs are built the same as described in the Bore Mode 3 Axis. Only the differences will be discussed in this section.

#### In / Out Zero

The In/Out zero position for Lifters is the center line of the Cam Bore. An easy way to find the center of the cam line is to use the electronic probe. The following is an example of this procedure. Install the probe into the holder and the holder into the spindle. Bring the probe down until it is in the approximate center of the cam Bar Vertically. Press the Vertical Zero button now (this is only a temporary Vertical Zero position). Using the In/Out handwheel bring the probe up to the Cam Bar until it lights. Press the In/Out zero button here. Move the spindle up enough to clear the Cam Bar, move the probe to the other side of the Cam Bar. Bring the vertical down to the zero position. Hand wheel the probe into the Cam Bar until the light comes on. Note the In/Out position reading. Divide this reading by two. Bring the spindle up until it can clear the Cam Bar. Use the In/Out handwheel and move the In/Out position until it matches the divided number. This is the center line of the Cam Bar. Press the IN/Out Zero button now. The In/Out zero position has been set. The following illustration visual shows the above description.

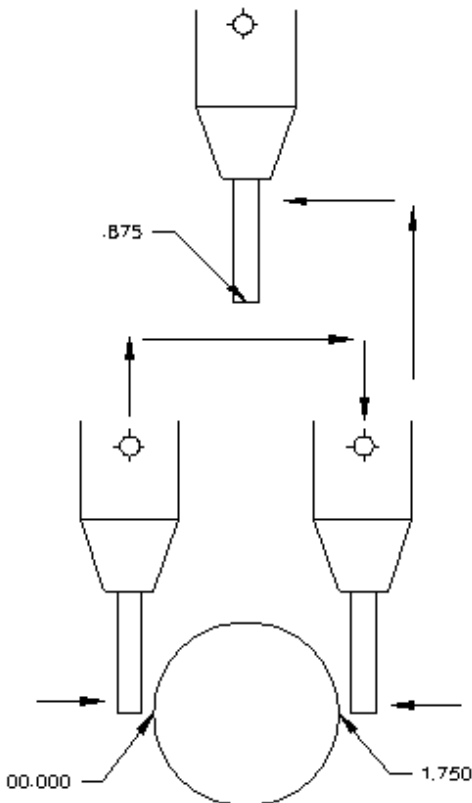

#### Start Boring Height

Pay particular attention when setting this height, there are often protrusions in the casting that will not allow the End Mill to travel unobstructed all the way to the start of the lifter bore. It is safest to set the Start Boring Height above the Deck.

#### Lifter Bore Angle

Rottler has specific Lifter Bore spacers that are installed on the Cam bar to set the correct angle for lifter boring when using the Performance Fixture.

### Lifter Bore 4th Axis

Lifter Bore programs are built the same as described in the Bore Mode 4th Axis. Only the differences will be discussed in this section.

#### Start Boring Height

Pay particular attention when setting this height, there are often protrusions in the casting that will not allow the End Mill to travel unobstructed all the way to the start of the lifter bore. It is safest to set the Start Boring Height above the Deck.

#### Lifter Bore Angle

The angle for each bank is located on the associated Locations page. Press the angle numerical value and a pop-up will open so you can type in the Lifter Bore angle.

#### Calculate In/Out

This button is located next to the In/Out Locations for each Bank. You must first have the Correct angle entered into the Angle data box. Then press the Calculate In/Out button. A window will open where you enter the center to center distance of the Cam to Crank bores. The In/Out locations will automatically be filled in.

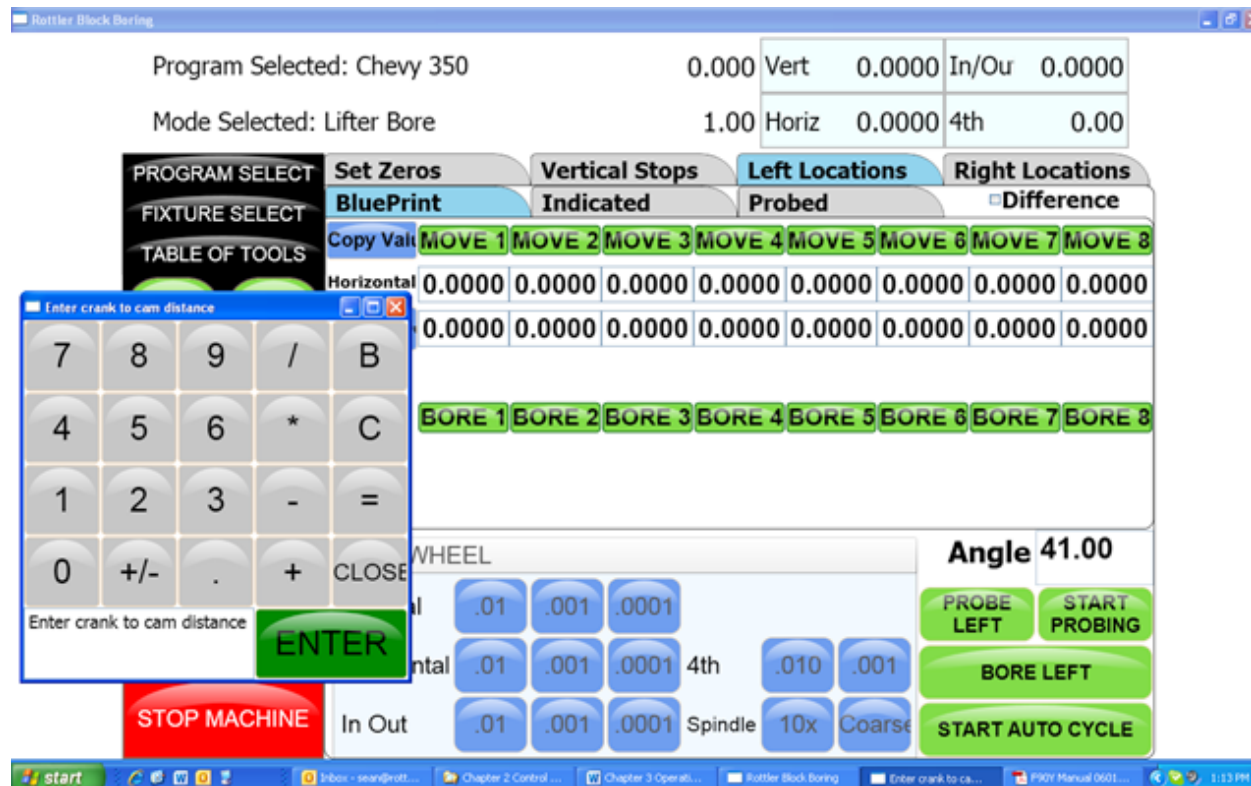

## Line Bore Mode

Select the Line Bore button from the Main Menu. This will bring up the Line Bore Mode with the Set Zeros tab shown.

## Mounting and Aligning the 90 Degree Head

Mount the 90 degree head onto the spindle and tighten the mount bolt. Use the following instructions to align the head.

Mount a .001" or .0001" dial indicator to the machine table or block. The 90 degree head has two machined surfaces that can easily be used to align the head. The two surfaces and indicator positions are shown below.

Put some pressure on the indicator. Using the In/Out handwheel move the indicator from one side to the

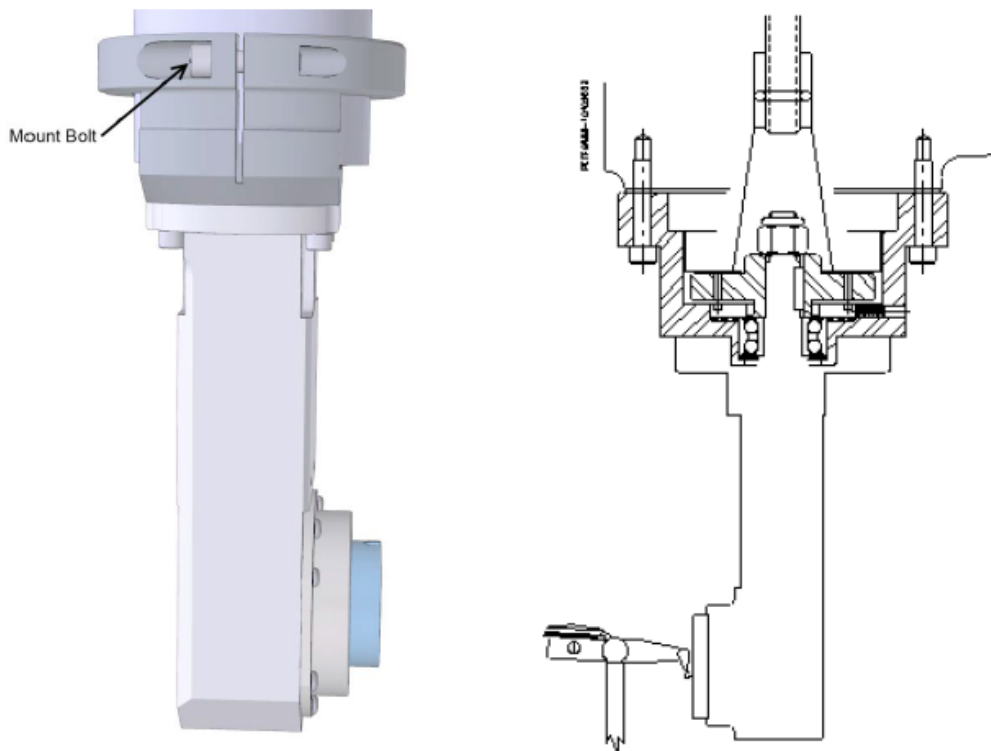

other noting the amount of difference. Keep the indicator on that side of the head and rotate it half of the noted distance. Repeat this procedure until there is less than .0005" variance.

Tighten the four mounting bolts for the head and check the surface again to be sure it did not shift when tightening the head.

## Setting Zeros

The purpose of setting zero points is to give the operator a specific point to build programs from. The machine also uses these zero points to run the program from. The zero points can be set at any point in the machines' travel. Each axis (except the Spindle rotation) will need to have a zero point set for the machine to operate from.



**Horizontal Zero**

The Horizontal should be set about .050" from the front of the first main to be bored, making sure that that position will allow the head to travel up without interference. Bring the head down and roughly center it in front of the first main. It does not need to be perfectly centered to set the horizontal zero. Press the Horizontal Zero button at this location.

**In/Out and Vertical Zero**

Locate the supplied Last Word indicator and small magnetic base. Mount on cutterhead as shown below.

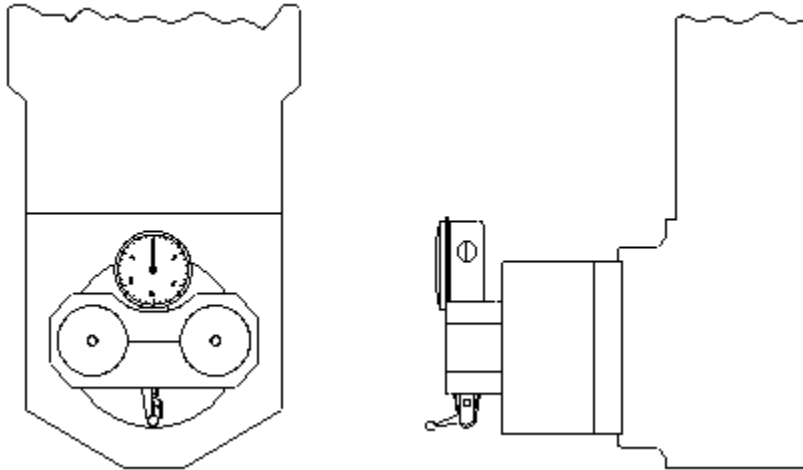

Using the Horizontal handwheel move the indicator inside the main bore, making sure the indicator is not touching the main bore at this point. You will be indicating both sides and the bottom of the saddle, generally the cap is not used to indicate from.

Physically move the indicator and mag base on the cutterhead until there is about .010" pressure on it. Start rotating the spindle CW and CCW watching the indicator. As there is too much or too little pressure on the indicator, use the In/Out and Vertical handwheel to adjust the spindle in the bore until all three points are equal. Press the In/Out and Vertical zero buttons at this point.

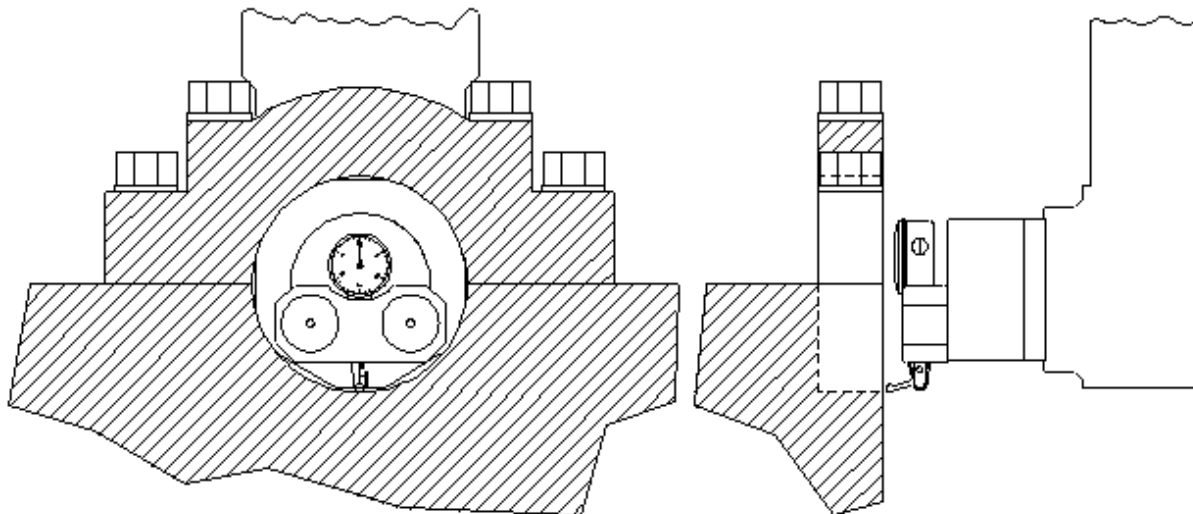

The Vertical stops have now been set. You are finished with the Program Vertical Stops screen, select the next Tab to the Right.



## Programming Vertical Stops

To build a program you must set the Vertical Stops. There are two (2) vertical stops used in the Line bore mode.

### Bore Centerline

The first vertical stop is on the main bore centerline. The vertical zero was set on the bore centerline. Therefore this stop will always be zero.

### Block Clearance

This stop is set at a **positive** value that will allow the 90 degree head to travel over the top of the cap and bolts to the next main bore unobstructed. In the case that there is not enough clearance to go over the caps, "Clearance Retract Angle" can be used.

### Clearance Retract Angle

When "Block Clearance" is set to zero, the Z axis will move straight up. If set to 90, (degrees) the Y axis will move in, or out to go around the caps because they can't go over the top. The amount specified by the "Block Clearance" value +, or -, will determine the length, and direction the Y axis to clear the caps. Any angle can be entered here, for example is 45 (degrees) is entered, both Y, and Z axis will move together at a 45 degree angle to clear the caps.

### Dwell RPMS

This is used when boring to a "step", maybe where an oil seal would be installed. RPM can be changed when it reaches the end of the "Bore Length" value to smooth out the finish of the step area.

### Dwell Revolutions

Value entered will determine how many times the spindle rotates at the "Dwell RPM's" to give a satisfactory finish of the bore step

### RAD options/Ratio

This is the gear ratio of the Right Angle Drive you are using.

Set Zeros	Vertical Stops	Bore Locations
BORE PROFILE		Dwell Options
Block Clearance	203.200 <input type="button" value="SET"/>	Dwell RPMS
Clearance Retract Angle	0.00	Dwell Revolutions
RAD Options		
Ratio	2.0000	

### Programming Horizontal Stops

The Horizontal Zero was set .050" before the first Main Bore, so the first Horizontal stop will be 00.000. Measure the distance between each main and enter it into the corresponding stop number.

### Programming Bore Length

Measure the length of each Main Bore and enter that value into the corresponding length box

### Deviation from main line

In the rare case where it is possible to probe all bore locations, checking this box will show how far each bore is away from Y, and Z zero

### Graph Probed Values

Used to give a visual picture of the actual main bore before and after

### Running the Auto Cycle

You will need to set a Feed Rate and Spindle RPM on the Set Zeros screen to run an auto cycle. The spindle will move up the Block Clearance distance as entered on the "Vertical Stops " page, move to the horizontal bore location, then will then move down to the zero position, spindle will start and feed to the "Bottom of Bore" length, retract horizontally out of the bore, go back up to "Block Clearance, move horizontally over to the next bore etc.

### **CAUTION**

If you press the MOVE buttons or the Cycle Start button the machine will not move the In/Out axis to the zero position. You need to move the In/Out axis to the zero position manually before you press Cycle Start.

The machine will go idle at this time. Pressing the "Start Auto Cycle" button will cause the entire cycle to run.

After a program has been completed the machine will move the spindle over to the first Main Bore at the clearance distance.

## Thrust Cutting

Refer to Line Bore in this section for mounting the block and aligning the 90 degree head.

Note: It is important to read through the entire Thrust Bearing Cutting section before entering any values or starting the Auto Cycle. You will better understand how the program operates and how the values affect the operation of the Auto Cycle.

The Thrust Cutting program can cut a single or double thrust face using circular interpolation.

Select the Thrust Bearing Cutting button from the Main Menu. This will bring up the Thrust Bearing Cutting Bore Mode with the Set Zeros tab shown.



## Setting Zeros

The purpose of setting zero points is to give the operator a specific point to build programs from. The machine also uses these zero points to run the program from. The zero points can be set at any point in the machines' travel. Each axis (except the Spindle rotation) will need to have a zero point set for the machine to operate from.

### Horizontal Zero

To set the Horizontal Zero, bring the cutter in using the Horizontal Hand Wheel until it just touches off the current thrust face. Press the Horizontal Zero Button here. The computer will use this zero point when cutting the depth of the thrust face.

Follow the procedure for setting zeros in the Line Bore Mode section of this chapter. Set the Horizontal zero on the Main Bearing that is to have the Thrust cut.

After the zeros have been set select the nest tab to the right, Dimensions.

## Dimensions & Auto Cycle

There are several values that need to be set on this screen for the program to operate properly. Below is illustration and a description of each of these values.



## Thrust Dimensions

### Outside

This is the Outside dimension of the thrust face to be machined.

### Inside

This is the Inside dimension of the thrust face to be machined.

### Cutter

This is the radius, from the center of the 90 degree head to the tip of the insert.

## Clearances

### Vertical

This is the distance, from zero, the 90 degree head will have to travel up to clear the main caps on the block.

### Horizontal

This is the distance, from zero, the 90 degree head will have to travel to clear the main for the next vertical move.

## Dimensions

### Main Width

Width of the Main.

**Insert Width**

Width of the Insert.

**Left Depth of Cut**

Depth of left cut.

**Right Depth of Cut**

Depth of right cut.

**Cut Right Side**

If you select Cut Right Side the automatic cycle will cut the thrust face on the right hand side of the Main.

**Cut Left Side**

If you select Cut left Side the automatic cycle will cut the thrust face on the left hand side of the Main.

**Description and Running of the Auto Cycle**

You will need to enter the Feed Rate and Spindle RPM the program will run at.

There are no Move to buttons in this program. You MUST be at the zero positions when the Auto Cycle is started.

**Start Auto Cycle**

When you are at the zero positions press the Auto Cycle, the spindle will start at the programmed RPM. The vertical feed will start at the programmed rate in an upward direction until the correct Outside diameter is reached. The circular interpolation will start at this point and go 360 degrees. It will then continue the circular interpolation back towards the center of the Main to clear the cutting tool from the thrust face. When the cutterhead is back at the center point (zero positions) of the Main, all motion will stop. The cutterhead will then rapid travel to the left taking the main width and the cutter diameter into account to reach the correct depth on the second thrust face. The same circular interpolation process will then be repeated for the second face. The cutterhead will then retract horizontally to the clearance distance then vertically to the block clearance distance.

When the program is running the "Start Auto Cycle" button will change to "Press to Pause". If this button is pressed the machine will pause the program right where it is. At this point the screens are locked out from changing anything. The button will change to "Press to Resume". If you want to resume press the button and the program will continue from that point on. If you do not wish to continue press the "Stop" button. This will put the machine back in idle mode and changes can be made to the program.

## Backing Up and Restoring Block Profiles

This section will explain how to back up and restore the operator created block profiles for DM controlled machines for archival purposes or to transfer to a different machine.

First step is to open your file browser and locate the RottlerWPF file on the C disk drive.

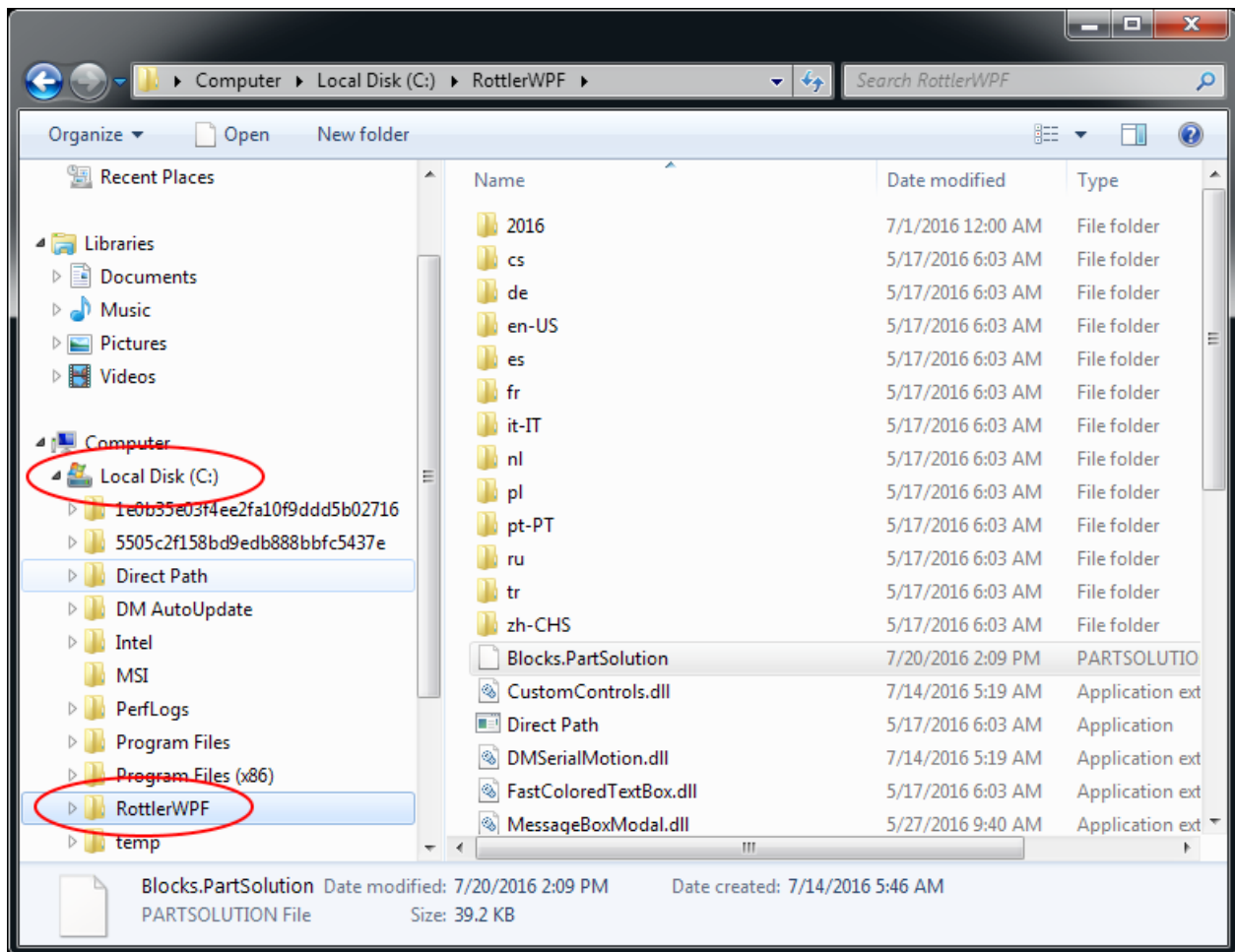

The next step is to plug in a flash drive to an open USB port



The following pop up box will appear on your screen.

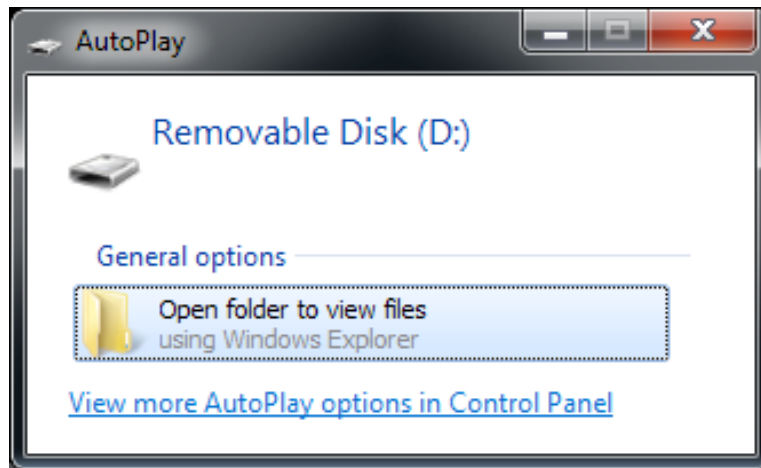

Click on the Open folder to view files option and the following screen will appear. This is the contents of the flash drive you just plugged in.

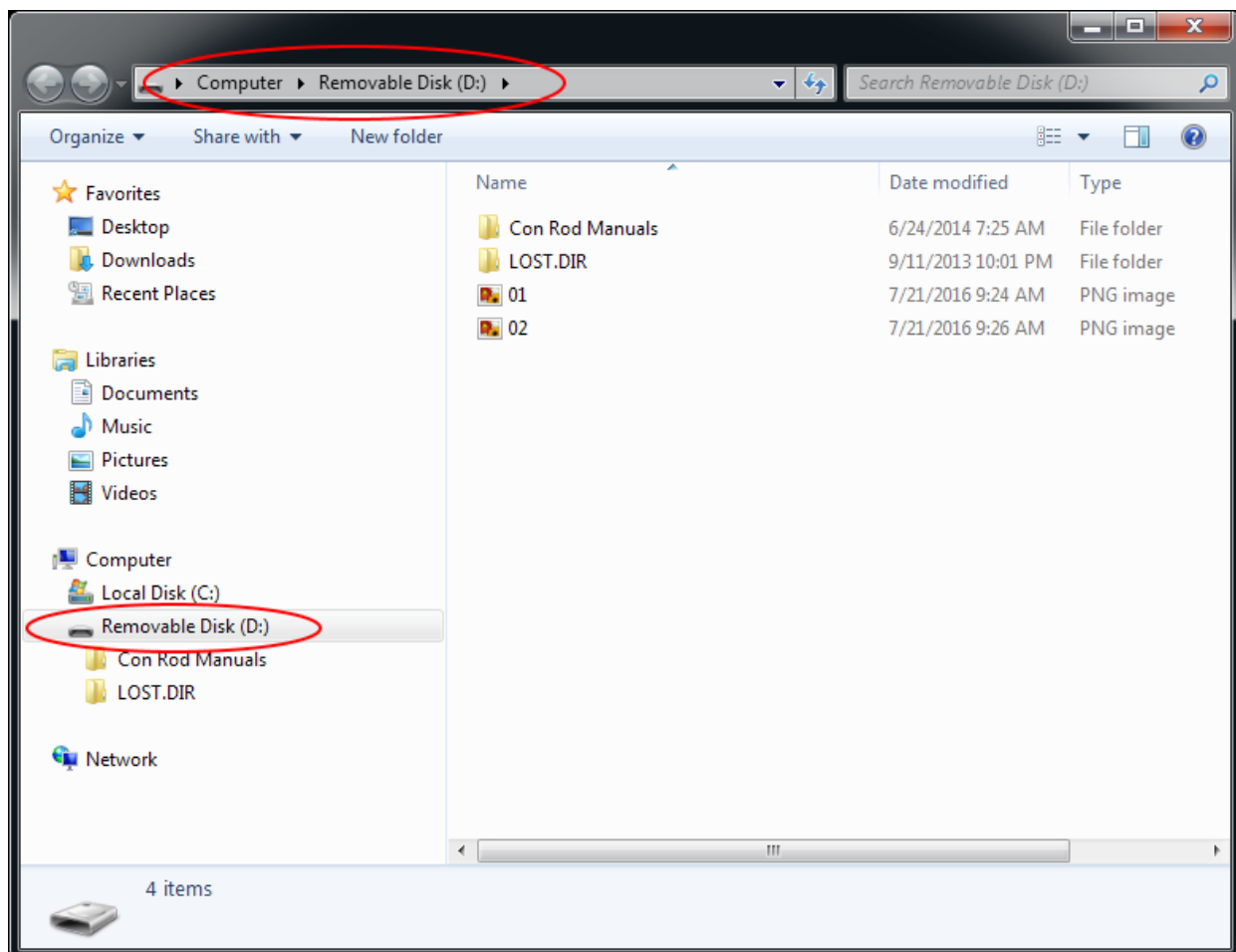

Next resize and arrange both file browsers so that they are side by side.

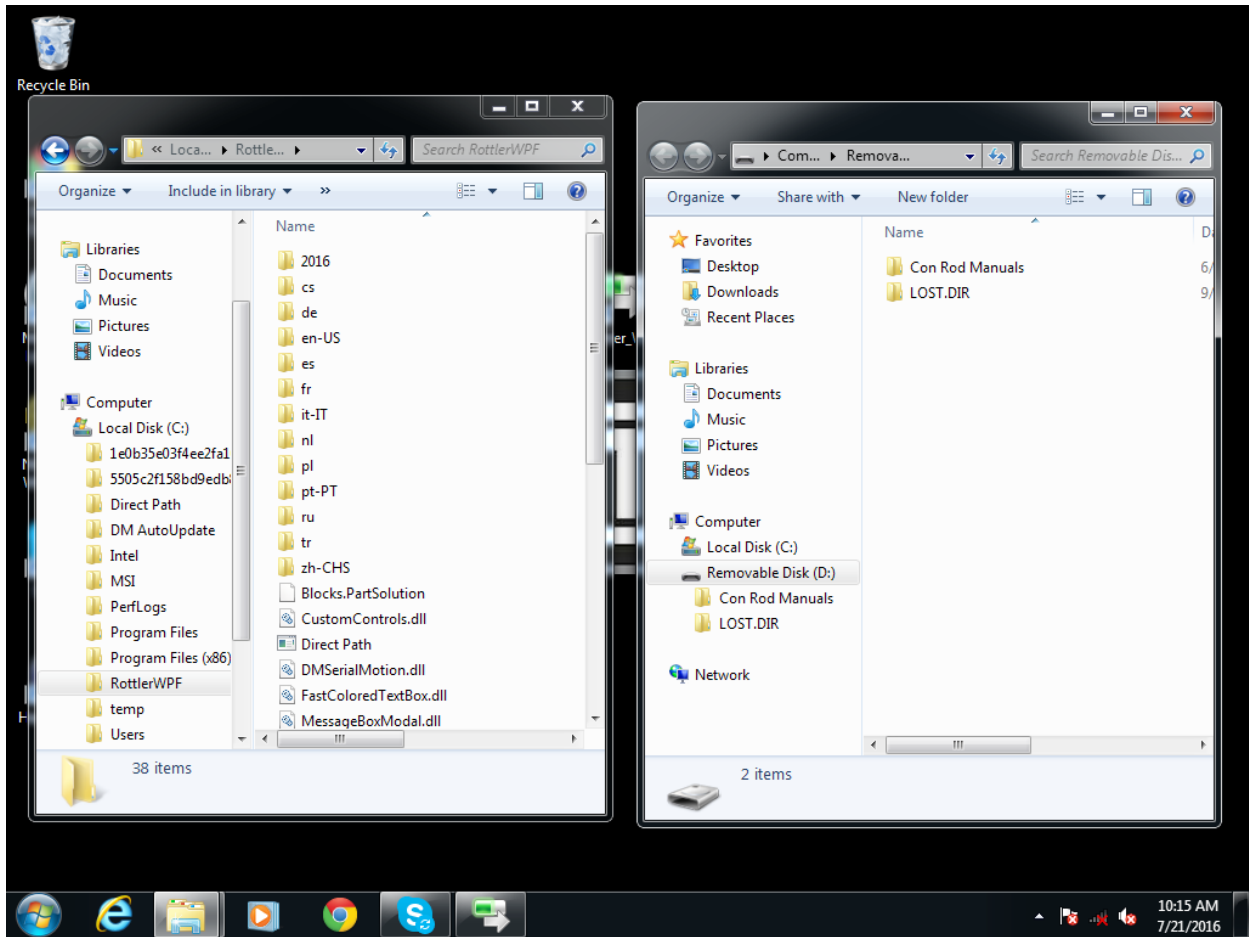



Block profiles are backed up each time the machine is run with the current profiles being shown in the RottlerWPF folder. All that needs to be done to back up the current profile is to simply drag it from the RottlerWPF folder to the flash drive folder. A copy of the file will be placed on the flash drive.

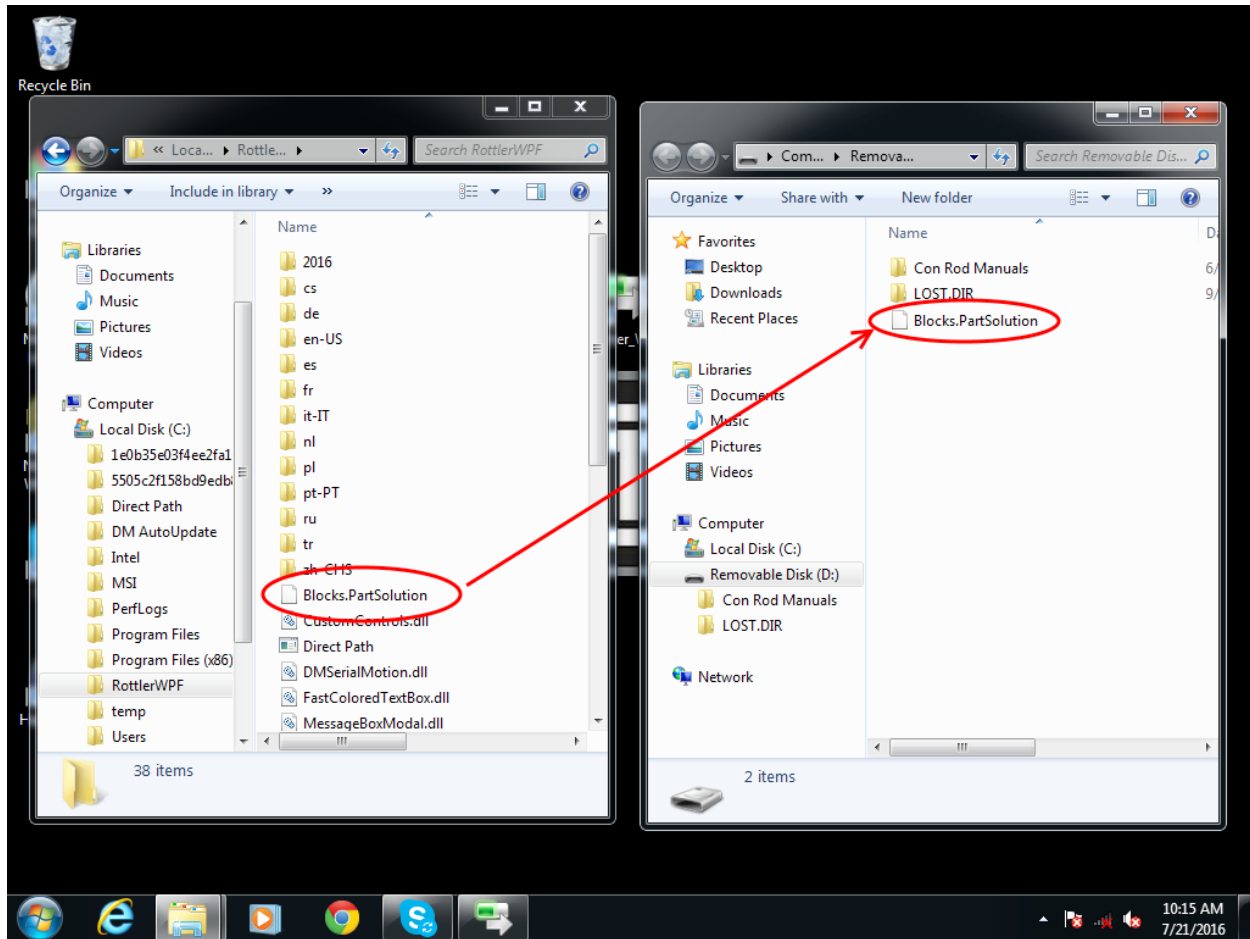

Backup is now complete. Close both file browser windows and remove the flash drive.

To restore or add block profiles go through the first 5 steps explained previously.

Highlight the block profiles file in the flash drive and drag it into the RottlerWPF folder on the local hard drive.

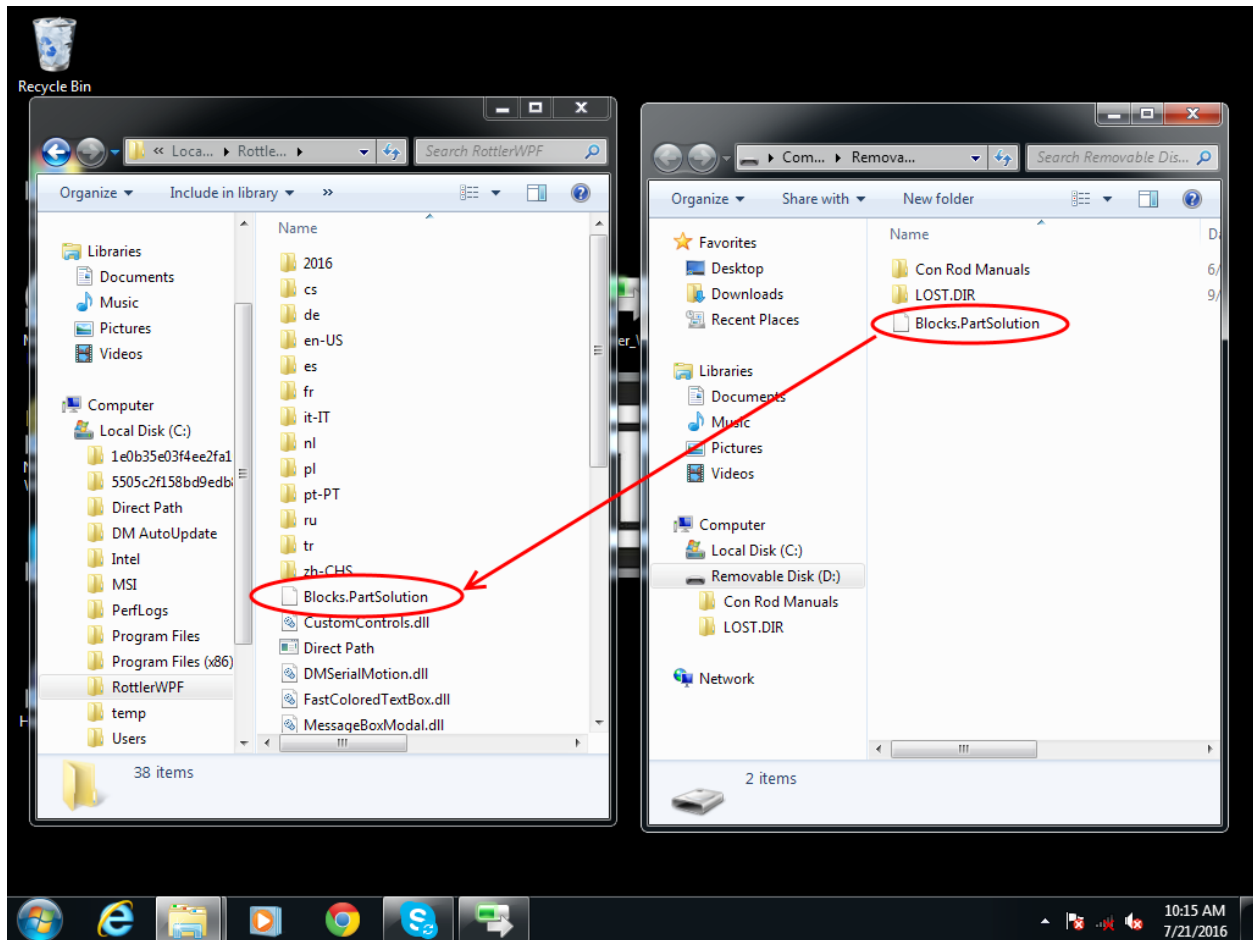

You will get a pop up window about there being a file of the same name in the destination folder. Click on the Copy and Replace option.

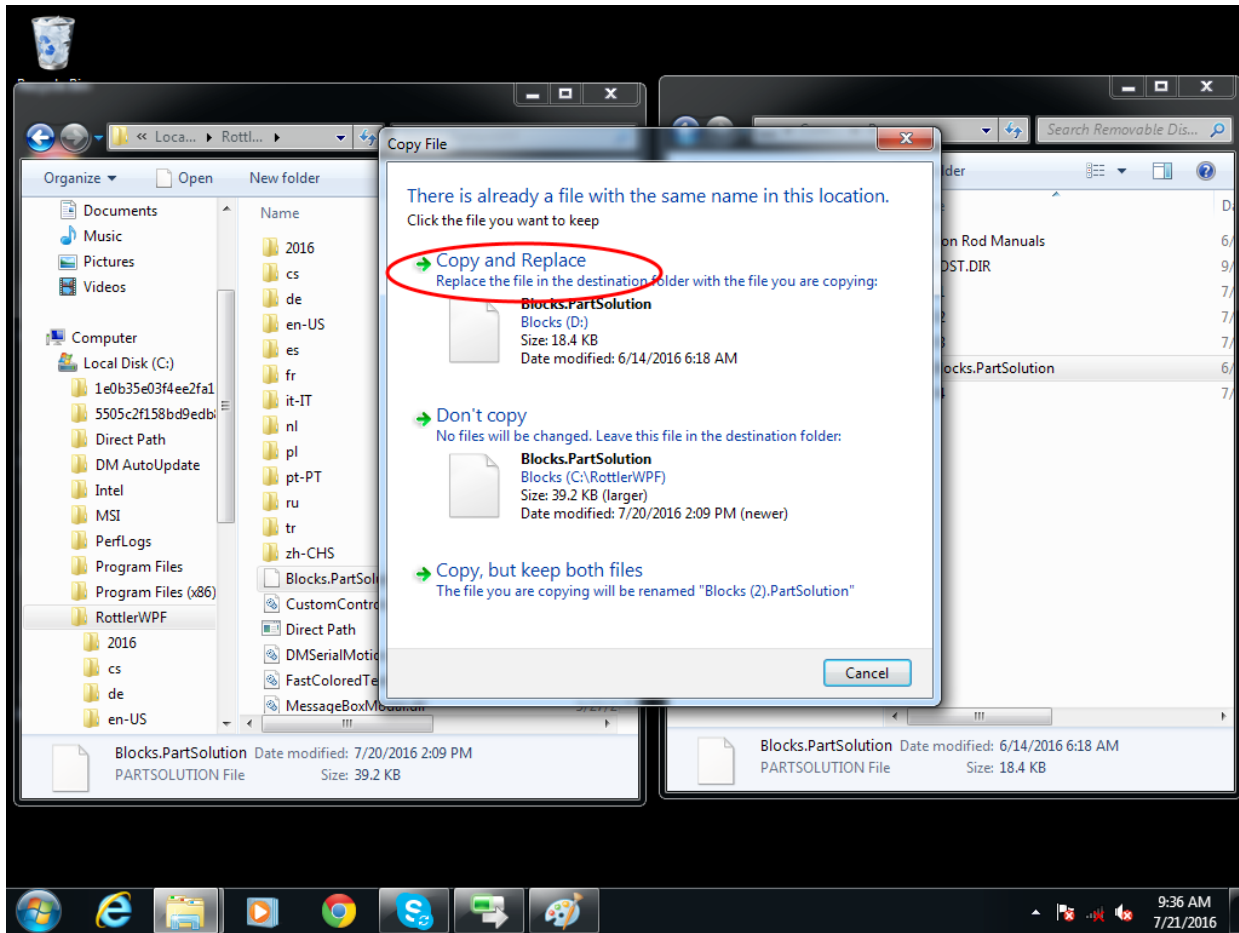

The archived block profiles will now be installed.

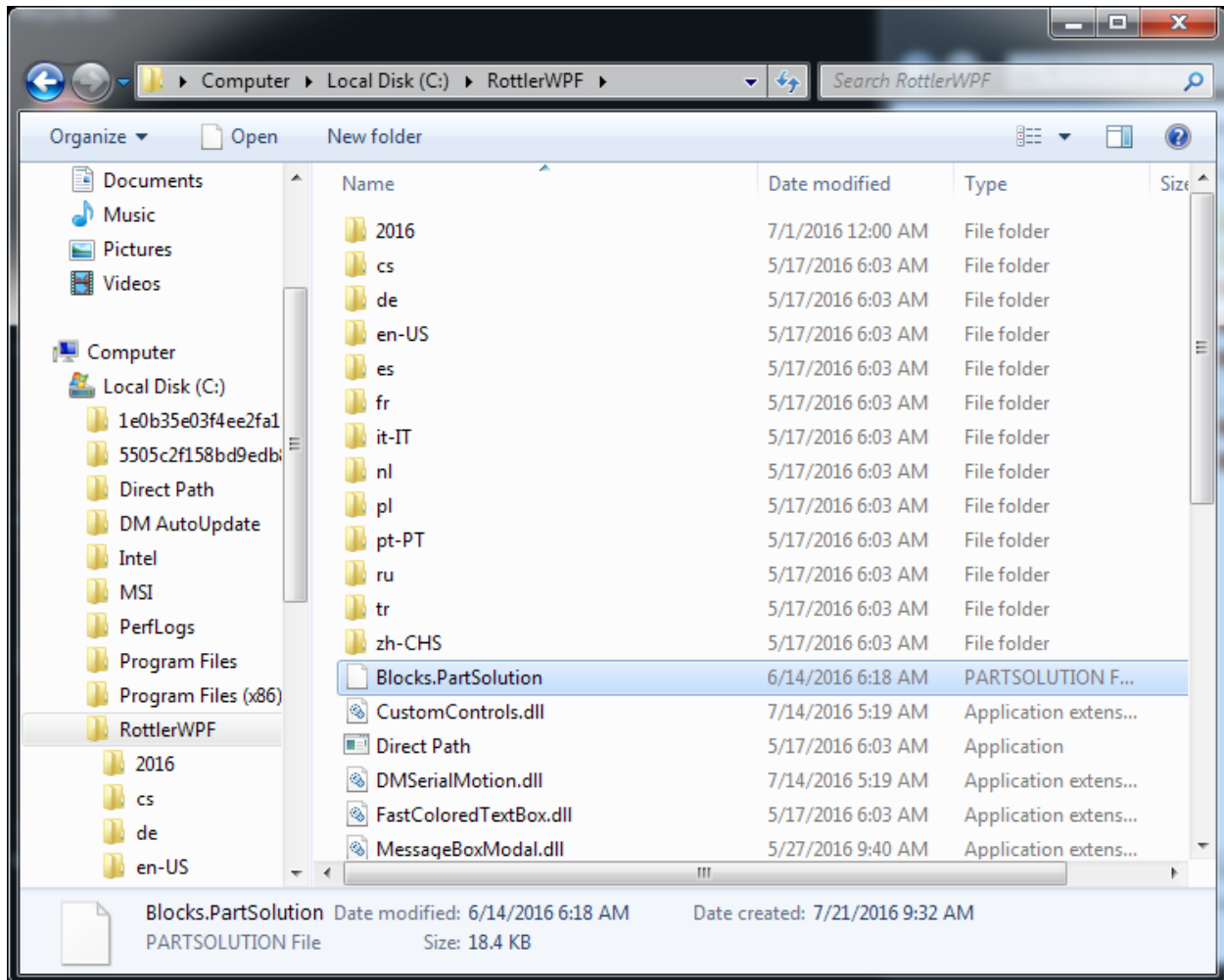

Close both browser windows and remove the flash drive. The restore process is now complete.

# MAINTENANCE

## Contents

<b>Maintenance</b> .....	<b>6-1</b>
<b>Lubrication</b> .....	<b>6-1</b>
Outer Spindle .....	6-1
Upper Belt Housing .....	6-1
<b>Oil Reservoir System</b> .....	<b>6-2</b>
<b>Inner Spindle Bearings</b> .....	<b>6-2</b>
<b>Vertical Ballscrew Bearings</b> .....	<b>6-2</b>
<b>Maintenance Schedule for Drawbar</b> .....	<b>6-3</b>
<b>Priming Spindle Base Oil Lines</b> .....	<b>6-7</b>
<b>Quick Reference Lubrication Chart</b> .....	<b>6-8</b>
Lubrication Locations .....	6-8
<b>Right Angle Drive Lubrication Information</b> .....	<b>6-9</b>
<b>Air Logic Diagram</b> .....	<b>6-10</b>
<b>F107/9 Wiring Diagram</b> .....	<b>6-11</b>
<b>ELO Alignment</b> .....	<b>6-12</b>
<b>Magnescale Set Up Instructions</b> .....	<b>6-14</b>
<b>Outer Spindle Bushing Adjustment</b> .....	<b>6-15</b>
Upper Bushing Adjustment.....	6-16
<b>Inner Spindle Adjustment</b> .....	<b>6-17</b>
<b>F107/9AHL Upper Housing Disassembly</b> .....	<b>6-18</b>
<b>F107/9AHL Inner Spindle Removal</b> .....	<b>6-19</b>
<b>Inner Spindle Angular Contact Bearing Replacement</b> .....	<b>6-19</b>
<b>Spindle Sweep</b> .....	<b>6-21</b>
<b>Adjusting Y-Axis Gibs</b> .....	<b>6-22</b>
Adjustment Procedure .....	6-23
<b>Backlash Setting .NET Software</b> .....	<b>6-24</b>

<b>Spindle Drive Belt Replacement / Adjustment.....</b>	<b>6-33</b>
<b>Mill Tilt Adjustment Procedure.....</b>	<b>6-38</b>
<b>Checking Wear on Column Turcite Pads.....</b>	<b>6-40</b>
<b>Preventative Maintenance Quick Reference Chart.....</b>	<b>6-42</b>
<b>Digital Micrometer setting instructions.....</b>	<b>6-43</b>
To set or edit micrometer .....	6-44
<b>Probe “On-Center” Adjustment.....</b>	<b>6-48</b>
<b>Replacing the Motherboard Battery.....</b>	<b>6-52</b>
<b>Ballscrew Assemblies Reference .....</b>	<b>6-55</b>
<b>Alignment Definitions for Angular Bearings and Belleville Washers.....</b>	<b>6-55</b>
Bearing Alignment .....	6-55
Belleville Washer Alignment .....	6-55
<b>Z-Axis Lower Bearing and Belleville Washer Stacking Order .....</b>	<b>6-56</b>
<b>Z-Axis Lower Bearing and Belleville Washer Section View.....</b>	<b>6-57</b>
<b>Z-Axis Upper Belleville Washer Stacking Order.....</b>	<b>6-58</b>
Z-Axis Upper Belleville Washer Section View .....	6-58
<b>Y-Axis Bearing Stacking Order .....</b>	<b>6-59</b>
Y-Axis Bearing Assembly Section View.....	6-59
<b>Inner Spindle Upper Segment Belleville Washer Stacking Order.....</b>	<b>6-60</b>
<b>Inner Spindle Lower Section Bearing Stacking Order .....</b>	<b>6-61</b>
Inner Spindle Lower Segment Section View .....	6-62
<b>X-Axis Idle End Bearing Stack Order.....</b>	<b>6-63</b>
X-Axis Idle End Section View.....	6-63
<b>X-Axis Drive End Bearing Stack Order.....</b>	<b>6-64</b>
X-Axis Drive End Section View .....	6-64

## Maintenance

### Lubrication

Refer to illustration following these written instructions:

Below are the directions that explain how and where to add oil to the different systems:

**CAUTION** Do not overfill any of the lubrication points, serious electrical damage may result.

### Outer Spindle

The Outer Spindle is hard chromed and is supported in tapered, cast iron spindle bushings. The Outer Spindle supports the Inner Spindle, bearings, seals etc... and maintains the boring rigidity.

#### Every 8 hours:

The Outer Spindle needs to be moved down to the lower limit, wiped clean, and then lightly coated with a ISO VG 68 Way Oil. This is very important, if the spindle is allowed to operate dirty the cast iron dust will act as an abrasive on the spindle chrome. This will cause the spindle to wear prematurely. The outer spindle is a very expensive item to replace.

#### Every 1000 Hours:

Open the sheet metal cover from the front of the spindle unit. There is a large nut where the outer spindle passes through the top of the spindle base. Using a spanner wrench or punch carefully remove the upper nut.

**Note:** *Do not adjust the nut below the felt wiper (see the mechanical section for correct adjustment of this nut)*

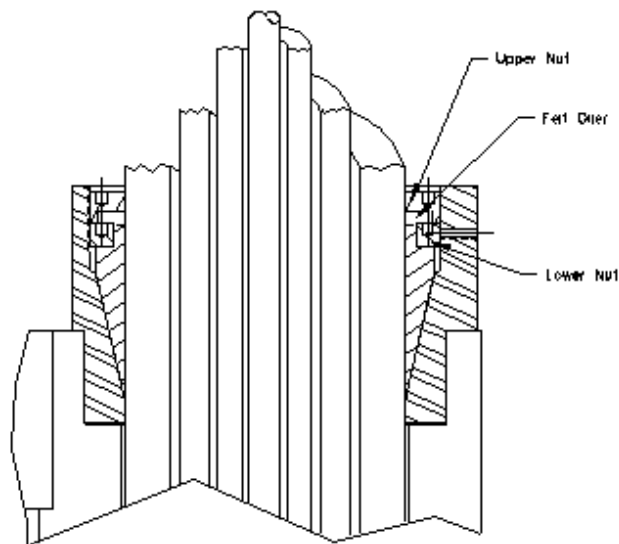

Slide the felt wiper back into place and tighten the Upper Nut back down.

### Upper Belt Housing

No lubrication is necessary in the Upper Belt Housing.

## Oil Reservoir System

### **IMPORTANT**

Every 8 hours check the oil supply lines to the upper spindle to be sure they are full of oil.

The oil reservoir system is located inside the lower portion of the column. This system lubricates the following:

- Ways
- Inner Spindle Bearings (Upper and Lower)
- Horizontal Ballscrew
- Outer Spindle

### **Every 175 Hours:**

The oil level of the reservoir should be checked, and filled with **ISO VG 68 Way Oil**.

When the oil reservoir is low or empty on the F107/9AHL machine, the control will “LOW OIL” and will not run until the reservoir has been filled.

The oil system may require priming if the reservoir has been run empty. You can do this manually or automatically. To prime automatically, change the oiler machine parameter #123 to a value of 10. This will turn the oiler solenoid on every ten seconds as long as the spindle is running. Take note when the oil lines are full, reset the oiler parameter and operate the machine normally. To prime manually, open the air door on the lower left hand side of the column, locate the blue solenoid, press the manual override button on the solenoid repeatedly until the oil lines are full. You need to pause for a second between button presses to allow the valve to reset. Pressing the button too fast will not pump oil through the system.

## Inner Spindle Bearings

The Inner Spindle Bearings are lubricated from the oil reservoir system. It is normal for a small amount of this oil to seep through the spindle bearings and onto the cutterhead.

## Vertical Ballscrew Bearings

The Upper Pillow Block bearing is located on the top plate just below the driven sprocket. The lower bearing set is located at the bottom of the ballscrew in the spindle base.

### **Every 175 Hours:**

Grease both ends of the X-Axis bearings.

These bearings should be greased with **NLGI #2 White Lithium Grease**.

### **Every 1000 Hours:**

Grease all 4 linear rail trucks with 4-6 pumps of grease.

These bearings should be greased with **NLGI #2 White Lithium Grease**.



## Maintenance Schedule for Drawbar

# 4 Maintenance

## 4.1 Preventive maintenance schedule

To guarantee the function of the power drawbar the following preventive maintenance schedule must be adhered to.

### Every week

- Check the packing ring in the clamping unit (visual check)
- Check the gripper, is it damaged or dirty, is it sufficient greased (visual check) ?  
Pay attention to:  
The regrease cycle depends on the loss of lubrication of the clamping unit.  
Cause for the loss of lubrication:
  - Seal in the clamping cone is defective
  - Type of medium used can desolve grease
  - Cleaning spray from outside directly on the clamping unit etc
- Note: METAFLEX Moly-Spray No.70-82 is recommended for a quick regreasing of the clamping unit without gripper-disassembly . (Rottler part # 10001U)

### Every six month or after 200.000 tool changes at the latest

- In unclamped position: Check dimension gauge E.M. —————> 4.5
- counter through a clamped tool again.
- Test Pull-in-force (we recommend:use Power-Check):  
If the pull-in-force is smaller than 70% of the nominal value, following procedures have to be performed in the following sequence:
  - regrease and test pull-in force again
  - exchange gripper and test again
  - exchange drawbar completely

**Clamping unit**

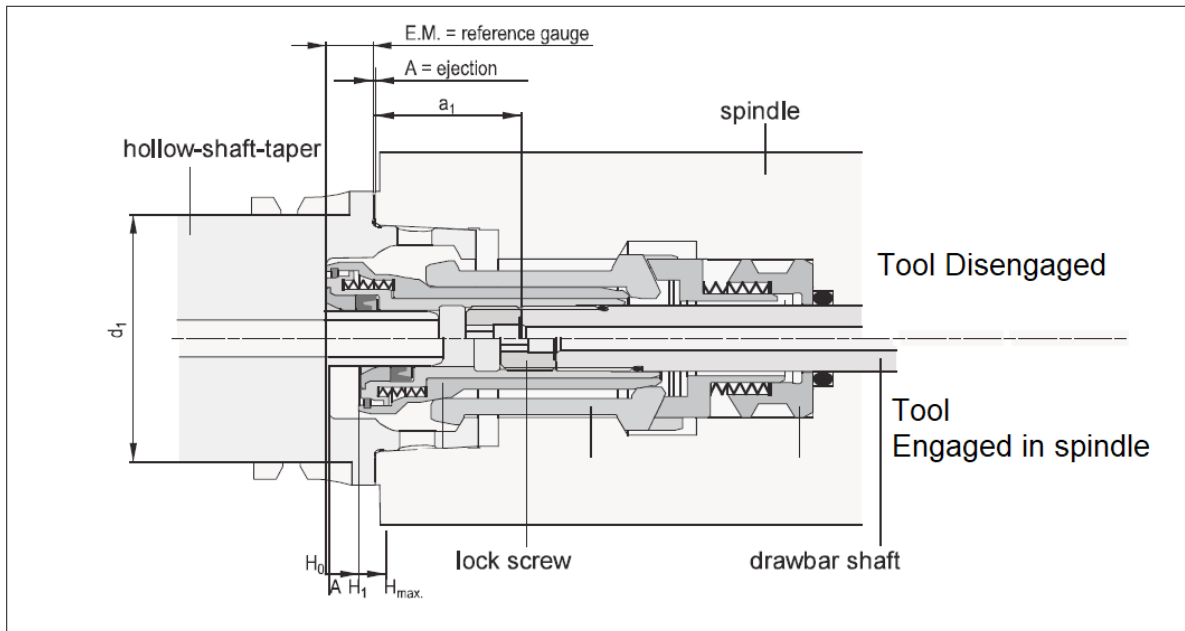

mm	<b>d<sub>1</sub></b>	<b>A80</b>	SAE	<b>A80</b>
	A	0,5		.019
	E.M.	13		.5118
	H <sub>max.</sub>	11		.433
	H <sub>1</sub>	8,3		.326
	a <sub>1</sub>	31,5		1.2401

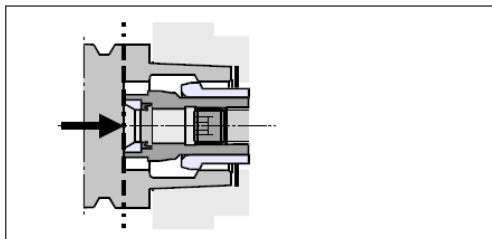

Do not insert tool into the spindle taper when rotating!

The tool has to be inserted all the way to the plane surface of the clamping cone to prevent misclamping!

standard size	A 80
tool changer force max. [kN]	5,6

4130 Ft.lbs.

#### 4.4 Trouble shooting HSK C

<b>trouble</b>	<b>reason</b>
tool is not pulled in correctly	gage dimension out of adjustment
	lock screw got loose
	wrong or faulty spindle-inside-contour
	wrong or faulty tool-inside-contour
	spring stack broken (travel not sufficient)
	wear of clamping unit
	tool feed not correct
	tool is in 180° backward in spindle
tool is pulled out during work cycle	gripper segments, clamping cone or drawbar broken
	tool shank broken
	springs broken
	pull-in force not sufficient
when in hold position, tool falls out of the spindle	tool is released thru cleaning air blast
	tool is pushed out of the spindle thru cleaning air blast
	axial acceleration too high
	unclamping speed too high
	gripper assembly worn - holding force insufficient
loss of pull force	lack of lubrication on clamping set
	<i>recommendation: check pull-in force!</i>

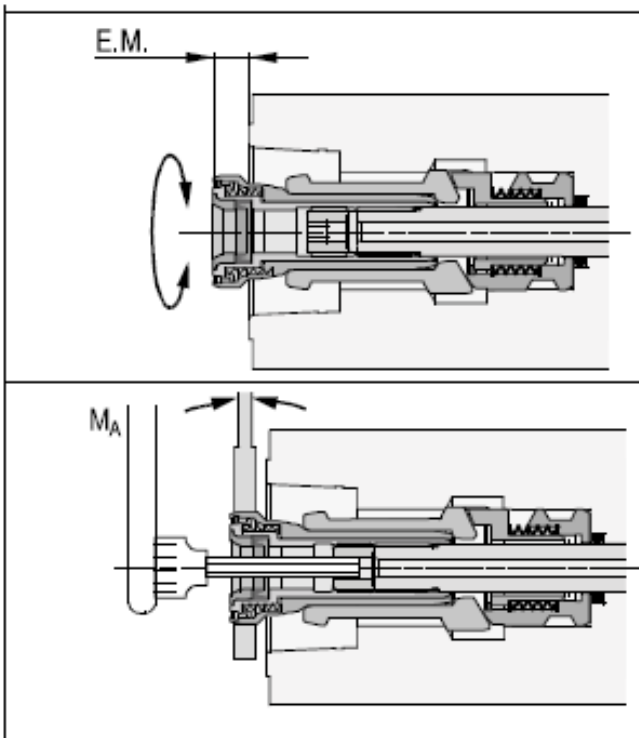
**4.5**

in unclamped position:

- adjust gauge dimension E.M.  
.5118 +/- .004  
13.0mm +/- 0.1

- tighten the lock screw

starting torque:

- A80 / B100: 30 Nm

### Priming Spindle Base Oil Lines

1. After the spindle base has been placed on the column the oil lines must be purged of air.
2. Remove the oil lines located on the spindle base guide rails.

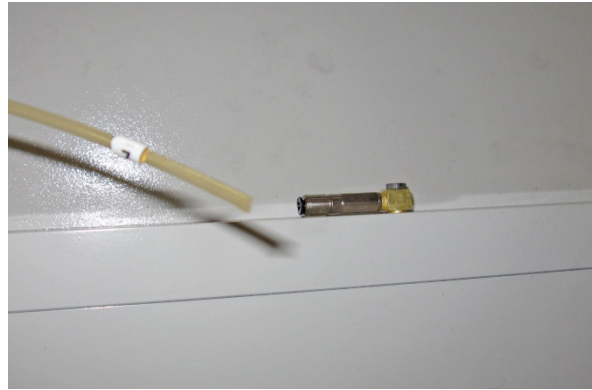

3. Open the door where the regulator is located.
4. Find the solenoid that has the #8 airline attached to it.
5. Manually activate the solenoid until oil flows out of the oil lines.

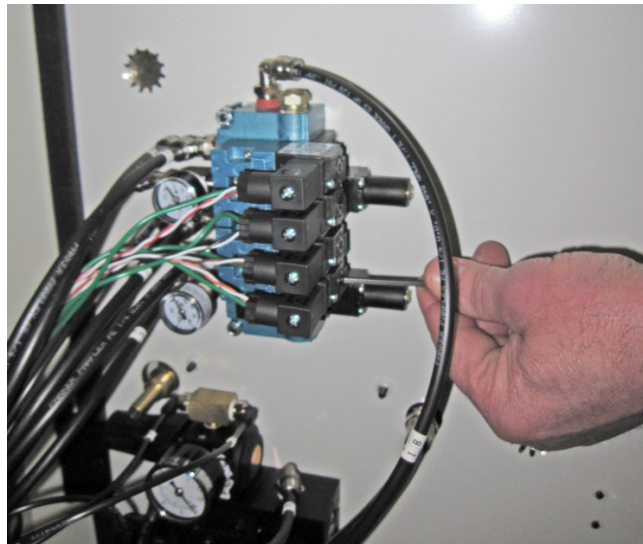

6. Reattach oil lines.

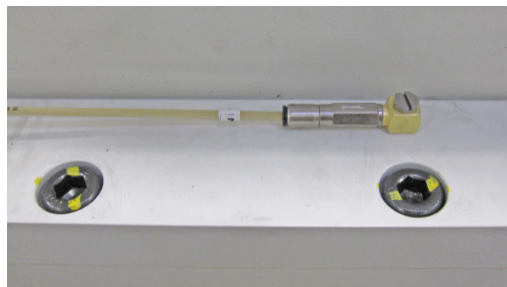

**Quick Reference Lubrication Chart**

Assembly	Frequency	Lube Operation
Outer Spindle	8 Hours 1000 Hours	Wipe with oil Soak felt wiper with oil
Oil Reservoir System	8 Hours 175 Hours	Check upper oil lines are full Fill reservoir with oil if needed
Pillow Block Bearings	175 Hours	Grease
Vertical Ballscrew Bearings	175 Hours	Grease
Swing Arm Hinge	1000 Hours	Grease
Column Feed Gear Housing	1000 Hours	Fill with oil

**Lubrication Locations**

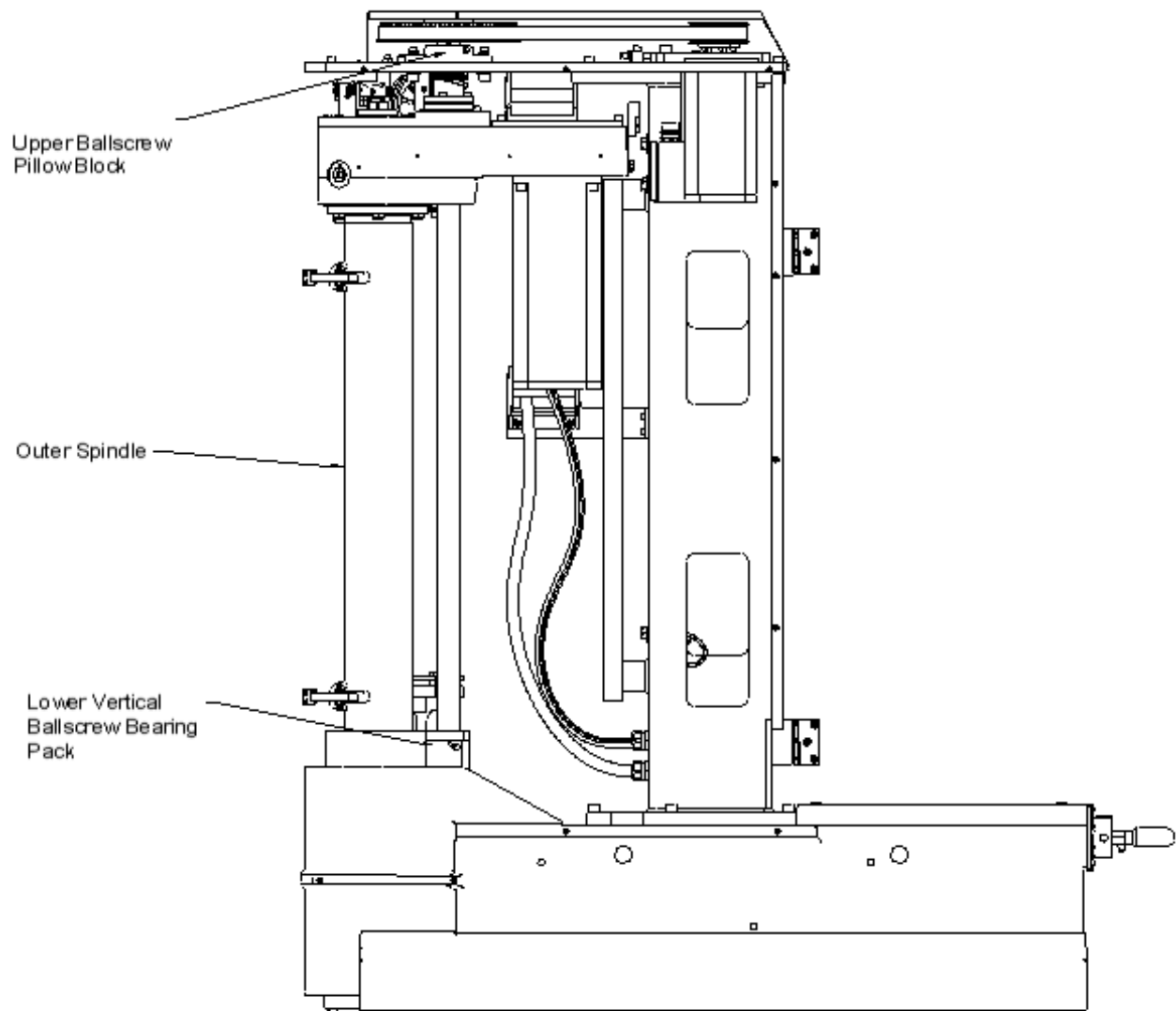

## Right Angle Drive Lubrication Information

All right angle drives require lubrication at the point where the pinion drive intersects with the drive gear. This is generally in the area where the cutterhead is attached, except for the units that have belt drive. There will be a small pipe plug that is removed to check oil level and add oil if needed. See illustration below for general locations.

With the drive mounted on the machine spindle the oil level should be even with the bottom of the pipe plug threads.

All Rottler Right Angle Drives are filled with Union 76 Turbine Oil 68 prior to shipment. Use this or an equivalent ISO VG68 oil if the need to add or change oil arises.

When adding oil, fill until oil starts to run out of fill hole. Allow excess oil to drain, then coat pipe plug threads with anti-seize compound and replace it.

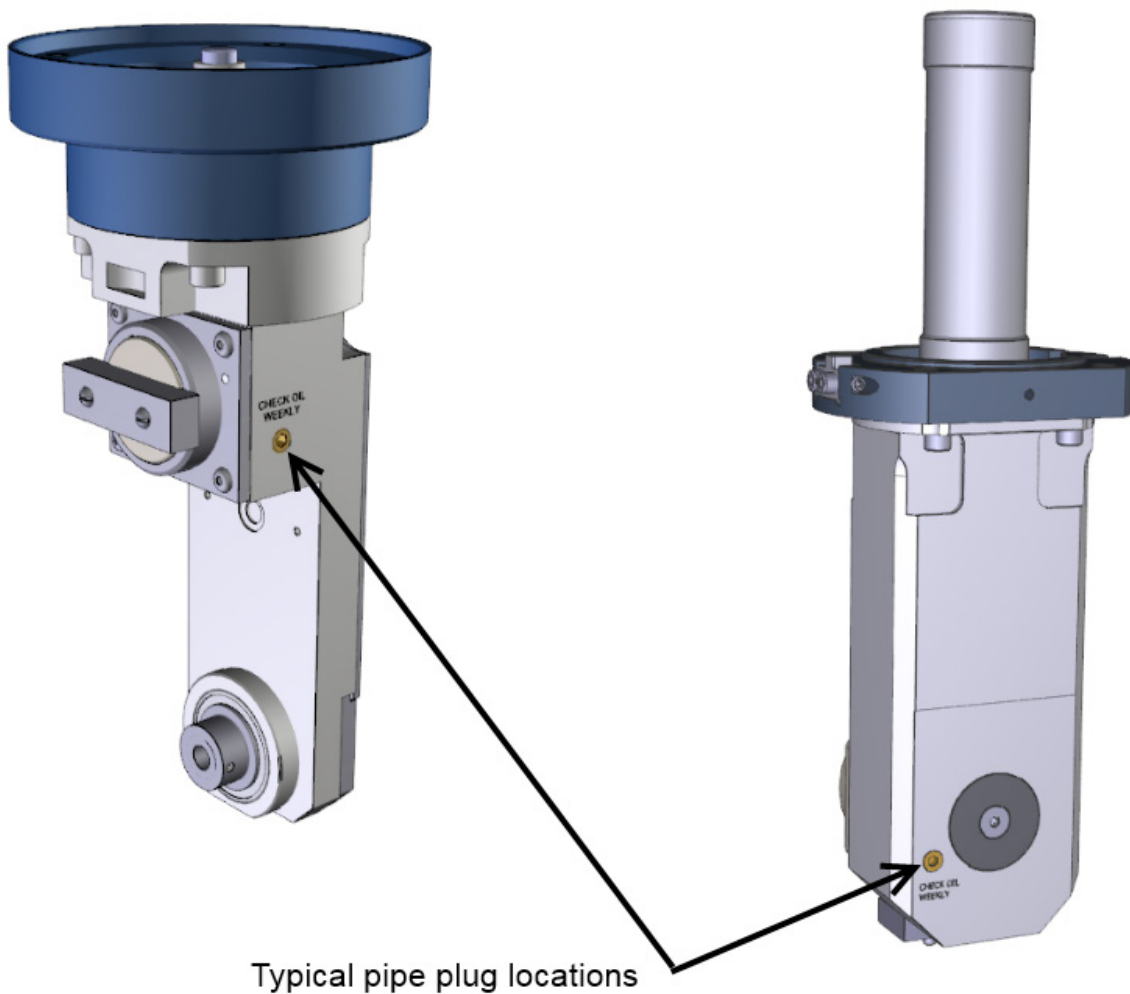

### Air Logic Diagram

A scalable version of this diagram is located on the manual CD.

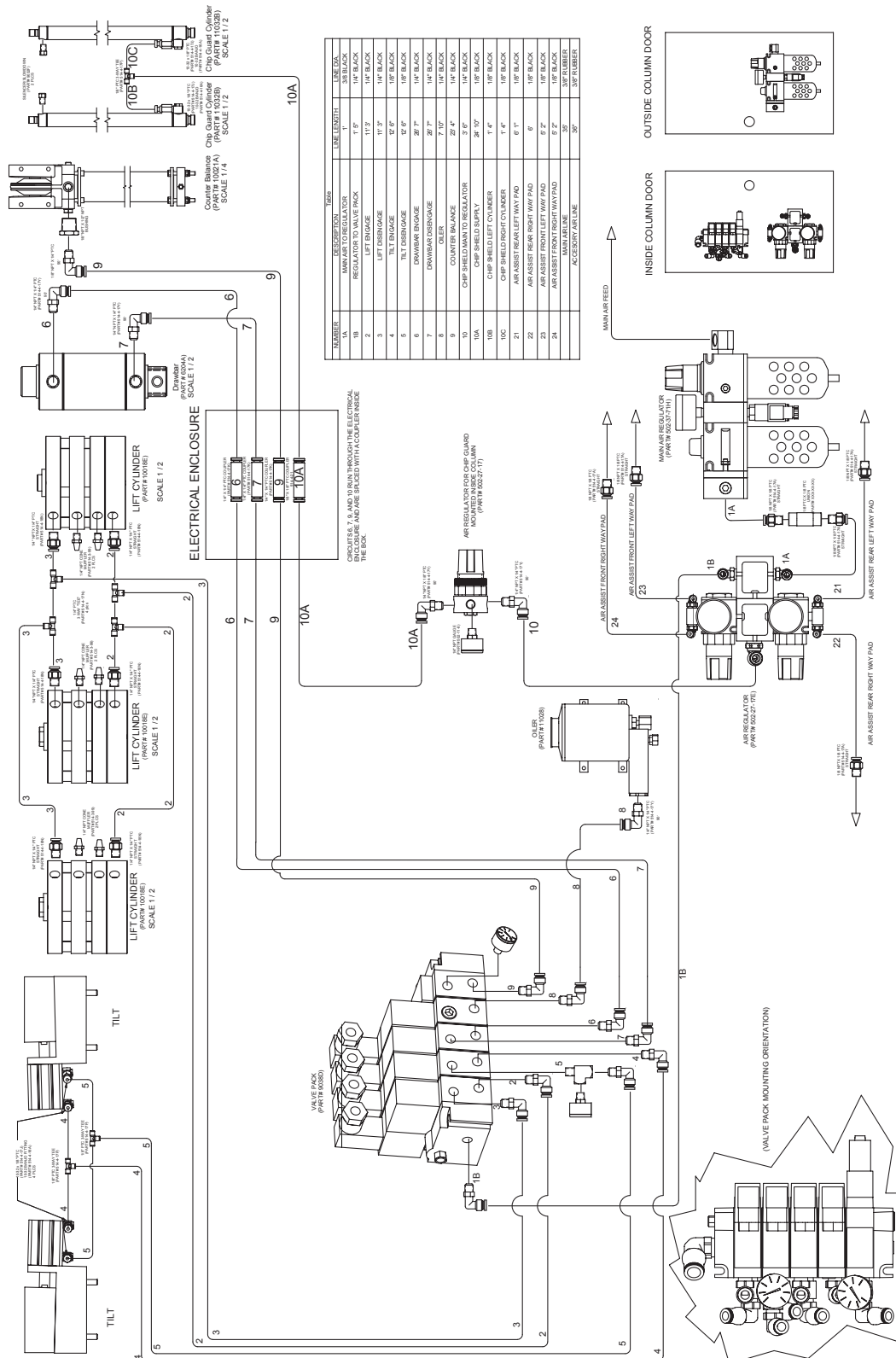



### F107/9 Wiring Diagram

A scalable version of this wiring diagram is located on the manual CD.

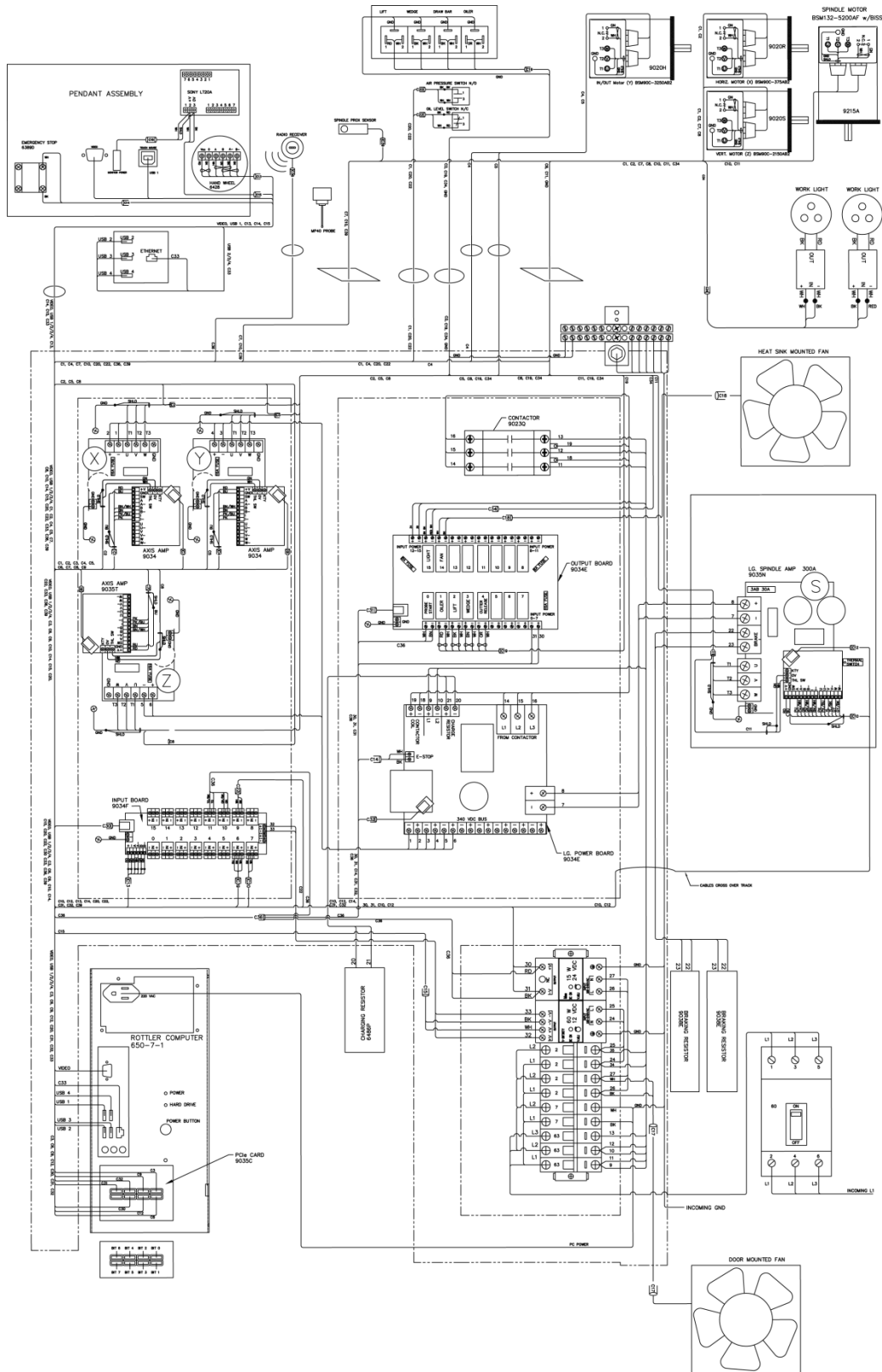

## ELO Alignment

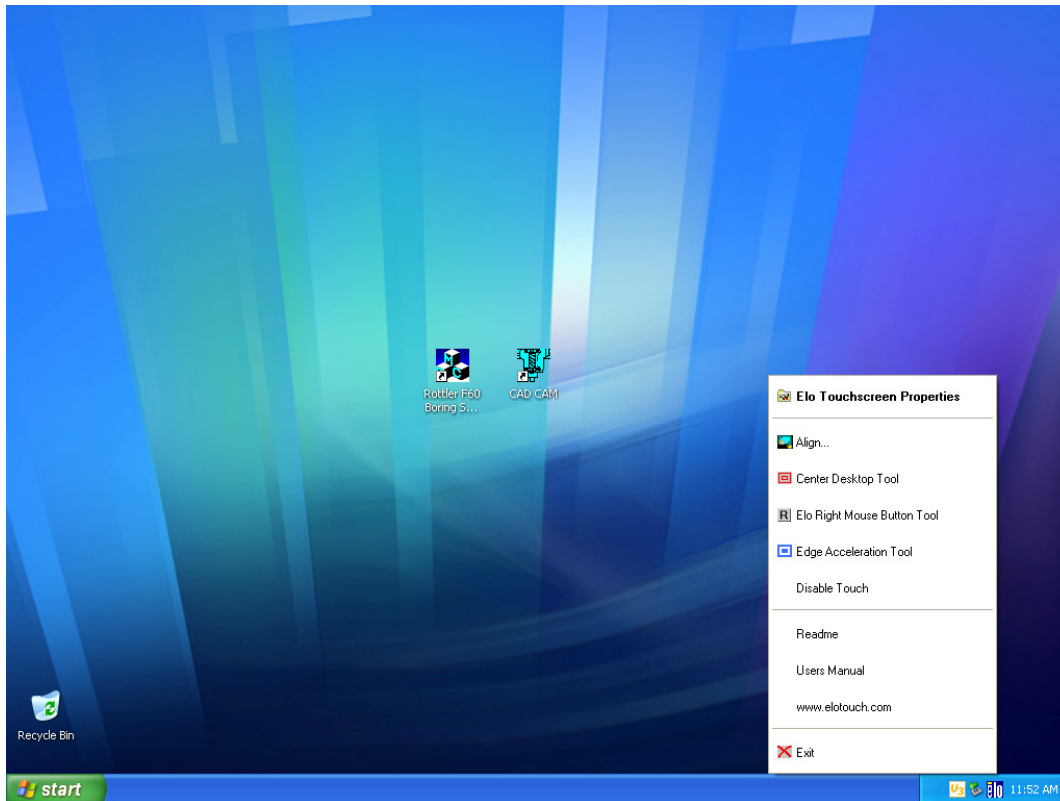

Find the small arrow in the lower right hand side of your screen.

Click on the ELO icon in the lower right, by the clock. Then click on Align.

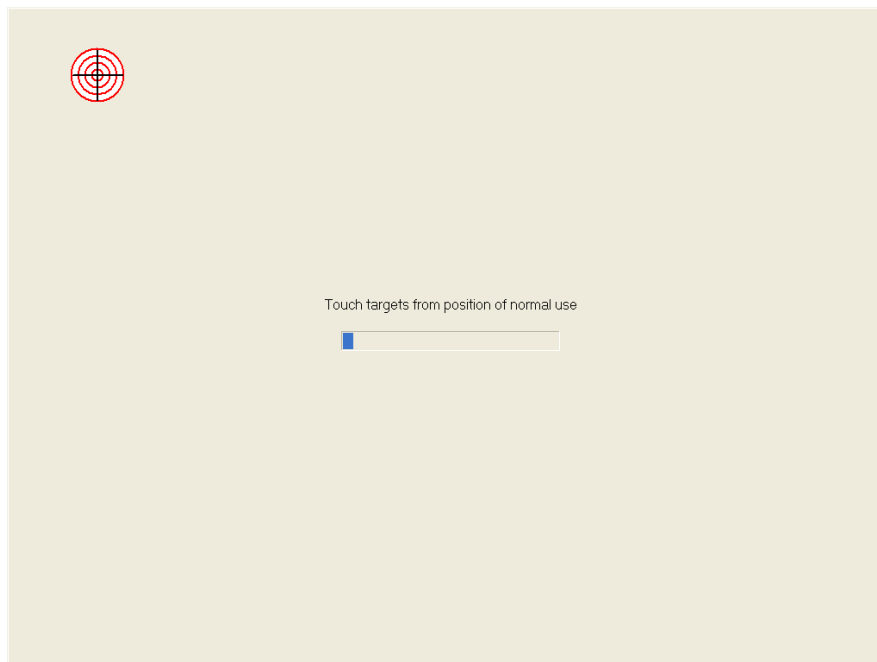

Touch the center on each of the targets.

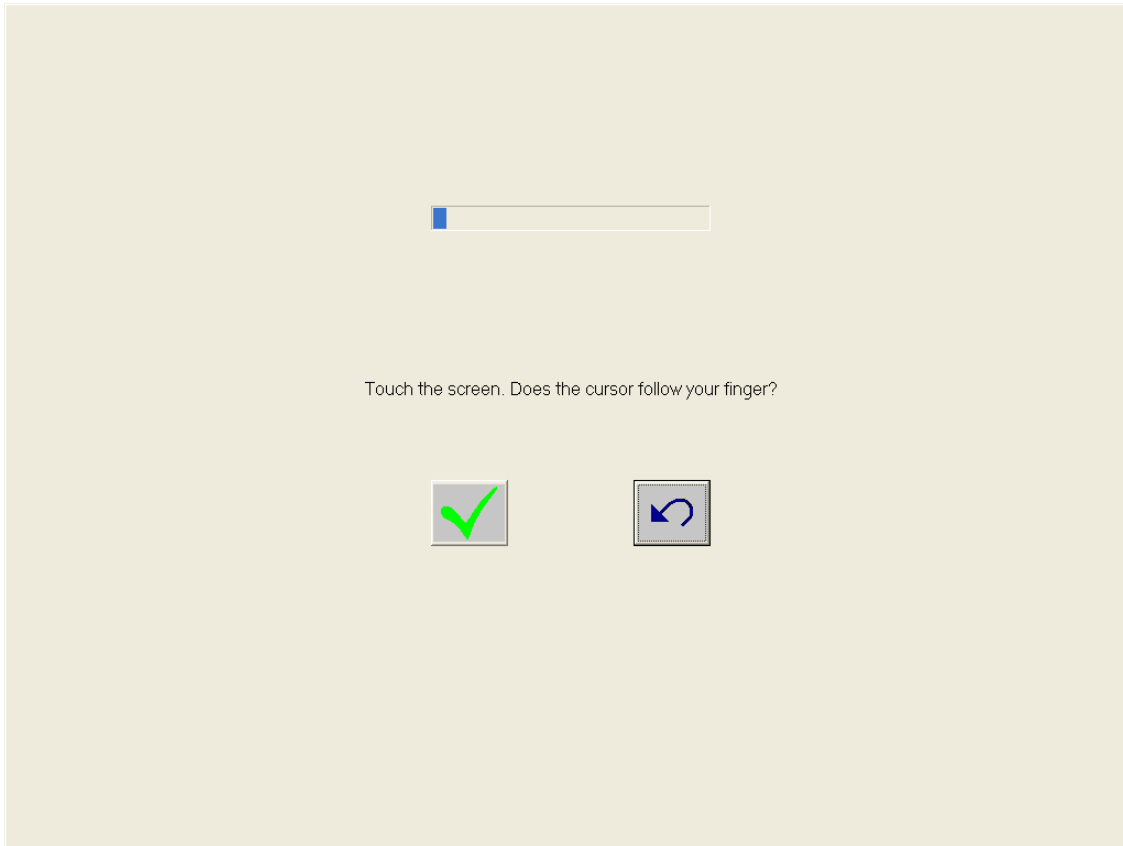

When this screen appears touch around the screen to make sure the arrow follows your finger. If it is good click the green check mark. If not click the blue arrow to do the alignment again.

## Magnescale Set Up Instructions

- Turn off power to Magnescale by unplugging the connector on the back of the unit. Or having someone else shut off the power while you stay in front of the unit.
- Plug it back in while you are holding down the reset button. You will see either “mm” or “in”
- While the still holding the reset button down, press the mode button and both the “mm” or “in” will start blinking, you are now in edit mode.
- You can now release the reset button, use the up arrow to switch between “mm” and “in”.

### Setting up sensor stroke depth:

- Press and hold set and mode until options menu starts blinking. Push mode once to switch to rSLP and then press up arrow to set +.0005.



- Push set once, and then mode ONE time, then rSL should be blinking
- Press and hold set and mode until options menu starts blinking. Push mode once to switch to rSL and then press up arrow to set +.0002.



- Push set once, and then mode until you exit options menu.
- To set and exit edit mode press set.
- Depress the plunger it should go between .2000-2500

## Outer Spindle Bushing Adjustment

The Lower Spindle Bushing will be adjusted in this demonstration.

1. Start the Rottler Software.
2. Move the spindle to its full downward position.



Retainer – O-Ring and felt are underneath

3. Loosen the four 10-24 bolts in the Retainer and pull out the O-Ring and Felt.
4. Loosen set screw at top of Bushing Carrier.
5. Take a punch and tighten Lower Bushing Nut with palm of hand. Raise spindle 5” and repeat. This helps set the bushing in the bushing carrier.

***(WARNING: Do not tighten Spindle bushing retaining nut when spindle is at the top 3” of travel. Excessive wear and premature failure could result.)***

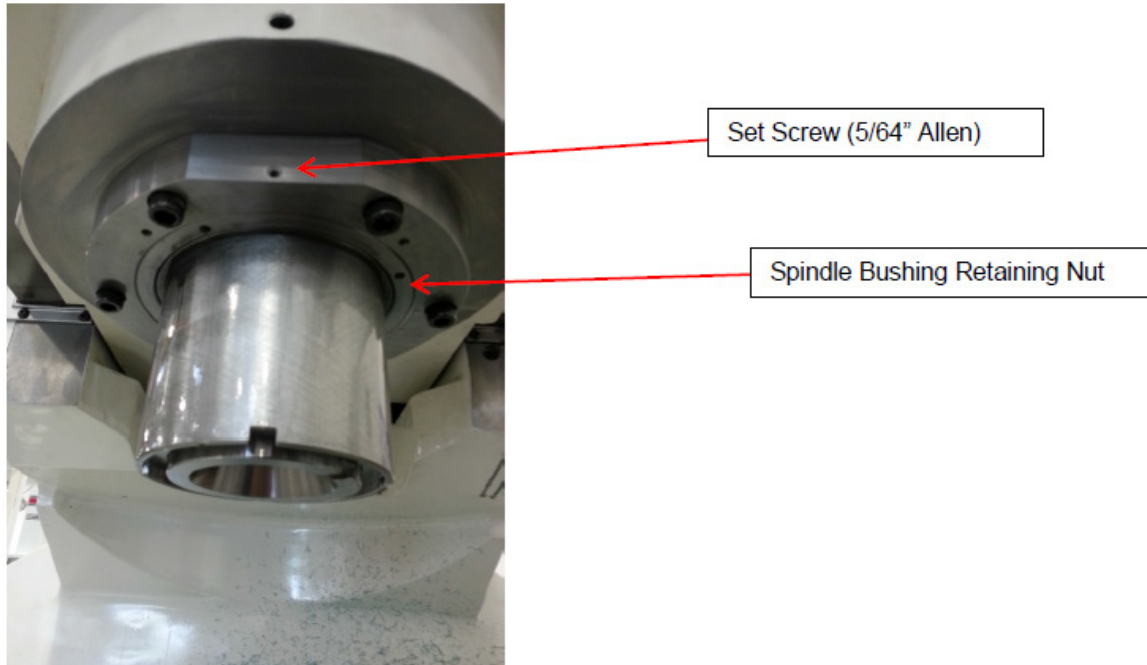

6. Once the Retaining Nut will not tighten any more, a couple soft taps with a punch and a hammer to tighten it is all that is necessary to finish procedure.
7. Re-Install Felt, O-Ring, then Retainer in that order. Tighten down (4) 10-24 bolts.
8. Tighten Set Screw in Bushing Carrier.

### Upper Bushing Adjustment

9. Be sure Spindle is at its home position (full upward position).
10. Repeat steps 3 and 4.
11. Take a punch and tighten Lower Bushing Nut with palm of hand. This time Lower spindle 5" and repeat.

***(WARNING: Do not tighten Spindle bushing retaining nut when spindle is at the top 3" of travel. Excessive wear and premature failure could result.)***

Once the Retaining Nut will not tighten any more, a couple soft taps with a punch and a hammer to tighten it is all that is necessary to finish procedure.  
Re-Install Felt, O-Ring, then Retainer in that order. Tighten down (4) 10-24 bolts.  
Tighten Set Screw in Bushing Carrier.

**Note: It is recommended to sweep in your spindle after this maintenance procedure.**

## Inner Spindle Adjustment

This adjustment should be made if you getting chatter or out of round bores.

Open the main spindle base door.

Install the surfacing cutterhead or a boring cutterhead with a long tool holder installed into the machine. Locate the opening on the belt housing. This is located at the top of the outer spindle. Inside is the inner spindle adjustment nut (6091A). The adjustment nut has hole drilled in it along it's perimeter to allow for an adjustment rod.

Insert the adjustment rod into one of the holes in the adjustment nut.

Rotate the head 1 turn Clockwise looking from the top, letting the adjustment rod move up against the end of the slot in the belt housing. This will loosen the inner spindle adjustment.

Now carefully turn the cutterhead Counter Clockwise looking from the top. The cutterhead will turn easily and you should be able to feel the spring loaded ball detent in the nut. At some point the torque required to turn the cutterhead will sharply increase, immediately stop turning the cutterhead. This indicates that the Belleville washers have collapsed and the bearing is bottomed out.

**IMPORTANT: DO NOT OVER TIGHTEN, SEVERE BEARING DAMAGE WILL OCCUR AND REPLACEMENT WILL BE NECESSARY.**

Now turn the cutterhead Clockwise of detent.

Remove the adjustment rod, the inner spindle is now properly adjusted.

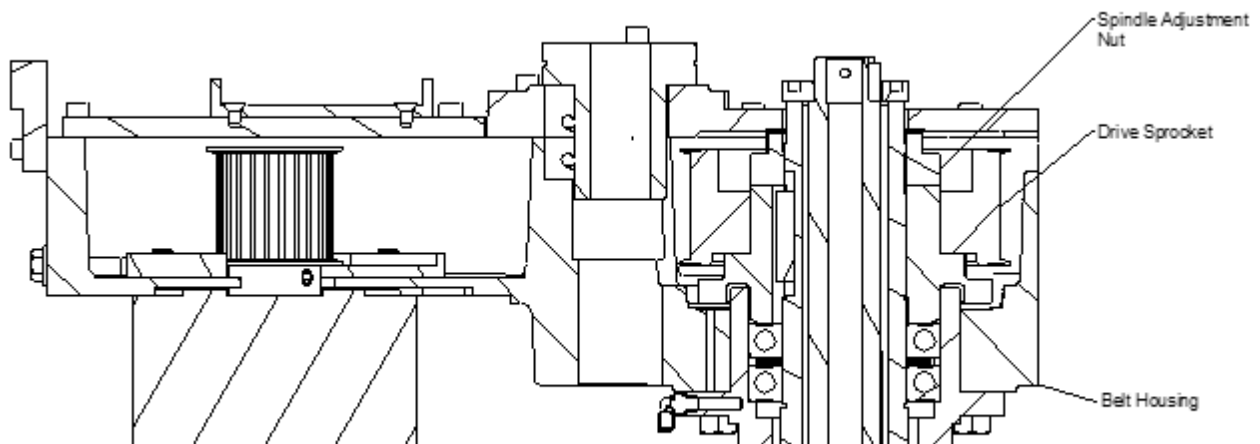

## F107/9AHL Upper Housing Disassembly

Travel the machine to the right Home position.

Remove the spindle base door and right side cover.

Place a board across the spindle base directly below the spindle motor (6790K or 6790U). Lower the spindle until the motor just touches the board.



Disconnect all power and air to the machine before continuing, severe bodily injury may occur.

Remove the four (4) bolts securing the motor the belt housing. Remove the two (2) bolts that secure the cable carrier (6314K) to the upper housing. Remove the oil and air lines from the upper housing.

**Note: It is not necessary to disconnect the spindle motor wiring.**

Rotate the vertical ballscrew by hand until it is about eight (8) inches from the top plate.

Place a board, of proper length, between the bottom of the upper housing and the top of the spindle base to prevent it from falling.

Remove the two bolts that secure the centering gear housing (6168H) to the belt housing. Work the centering housing up off the centering shaft. Tie it up to the top plate.

**IMPORTANT!!: Do not attempt to move the vertical under power when the centering housing is not bolted to the belt housing or the upper plate. Severe damage will result to the centering shaft!!**

Remove the Clevis Pin (7210B) from the draw bar actuator bracket (6174B). Lift the actuator arm (6173B), move the arm and cylinder off to the side. Remove the air cylinder (6204A), clevis pin (6189A) and mount bracket (6188C) from the side of the belt housing. Remove the two (2) bolts that attach the draw bar actuator bracket (6174B) to the to belt housing cover.

Remove the counter weight cable (6453 F or 6453G) from the upper housing by loosening the lock nut and unscrewing the cable nut.

**Note: When reassembling, be sure not to thread the cable nut in too far as it may come in contact with the driven pulley.**

Remove the eight (8) screws holding the inner spindle end cap (6180A). Unscrew these bolts slowly around the diameter of the end cap as they are under spring pressure from the draw bar. Remove the cap by pulling straight up.

**Note: When reinstalling, the end cap must be aligned concentric to the draw bar.**

Remove the three (3) screws that secure the vertical ballscrew nut to the belt housing. Holding the nut with one hand, turn the ballscrew with the other to move it up and out of the way so the belt housing lid can be removed.

Remove the bolts securing the belt housing covers. The covers are pinned to the belt housing. Use a soft face mallet to carefully remove the covers.

From this position you can remove and/or replace pulleys and belts.



### F107/9AHL Inner Spindle Removal

Prior to following these instruction, perform the steps in Upper Housing Disassembly.

**IMPORTANT: When removing bearings, bellevilles and spacers, not the direction they come off for correct reassembly.**

The driven pulley and inner spindle adjustment nut must be in place before continuing. Remove the LEFT HAND THREAD throwback ring (6305D) from the bottom of the outer spindle.

**Note: If the driven pulley and inner spindle adjustment nut are not in place the inner spindle will be able to fall out of the outer spindle.**

While supporting the inner spindle from the bottom, remove the inner spindle adjustment nut and driven pulley from the top.

The inner spindle is now free to be removed from the bottom. This spindle is precision fit into the outer spindle, it may be necessary to tap the top of the inner spindle with a soft face mallet to get the spindle to drop out.

**Note: Be sure of the thrust direction of the bearings on reassembly.**

Reassemble in the reverse order.

### Inner Spindle Angular Contact Bearing Replacement

Prior to following these instruction, perform the steps in Upper Housing Disassembly and Inner Spindle Removal.

Loosen the three (3) Allen head set screws on the shoelock nut (6116F).  
Loosen the shoelock nut and slide off of the top of the spindle.

**Note: Be very careful not to damage the threads when sliding nuts, bearings and sleeves off the top of the inner spindle. These are very fine threads used for the inner spindle adjustment nut.**

Remove the top bearing by tapping lightly and evenly on both sides of the bearing. After the bearing is moved slightly off of the spacer set (6172E) tap the inner race.

**Note: Tapping on the outer race can cause it to roll off of the bearings. Generally after removing the bearings from the inner spindle they are not suitable for re-use.**

Remove the spacer set.

Remove the two lower bearings (6116E) set of three (3) the same way as the top bearing.

Stand the spindle on end so that the bearing pack is nearest the floor.

Make sure inner spindle is free of all dirt and debris.

Lightly coat the lower bearing pack area with a light weight #10 oil.

If you have a bearing heater available to you, it is the preferred method of bearing installation. If not, follow the instructions below.

Slide the two (2) lower bearings onto the inner spindle with the correct bearing thrust direction until they stop. Use a small brass punch to lightly tap each side of the bearing on the inner race until both bearings are seated at the bottom of the spindle.

Install the spacer set.

Install the top bearing using the same procedure as the lower bearings until it is seated against the spacer set.

Install the shoelock nut and tighten with a spanner wrench until the inner races of the bearings and spacer set are fully seated together.

Tighten the three (3) set screws on the shoelock nut.

Place the inner spindle in a vise near the bearing pack and lock the vise.

Indicate the bearing set to within .0005" all the way around. Adjust the spacer set by tapping the high side lightly with a brass drift.

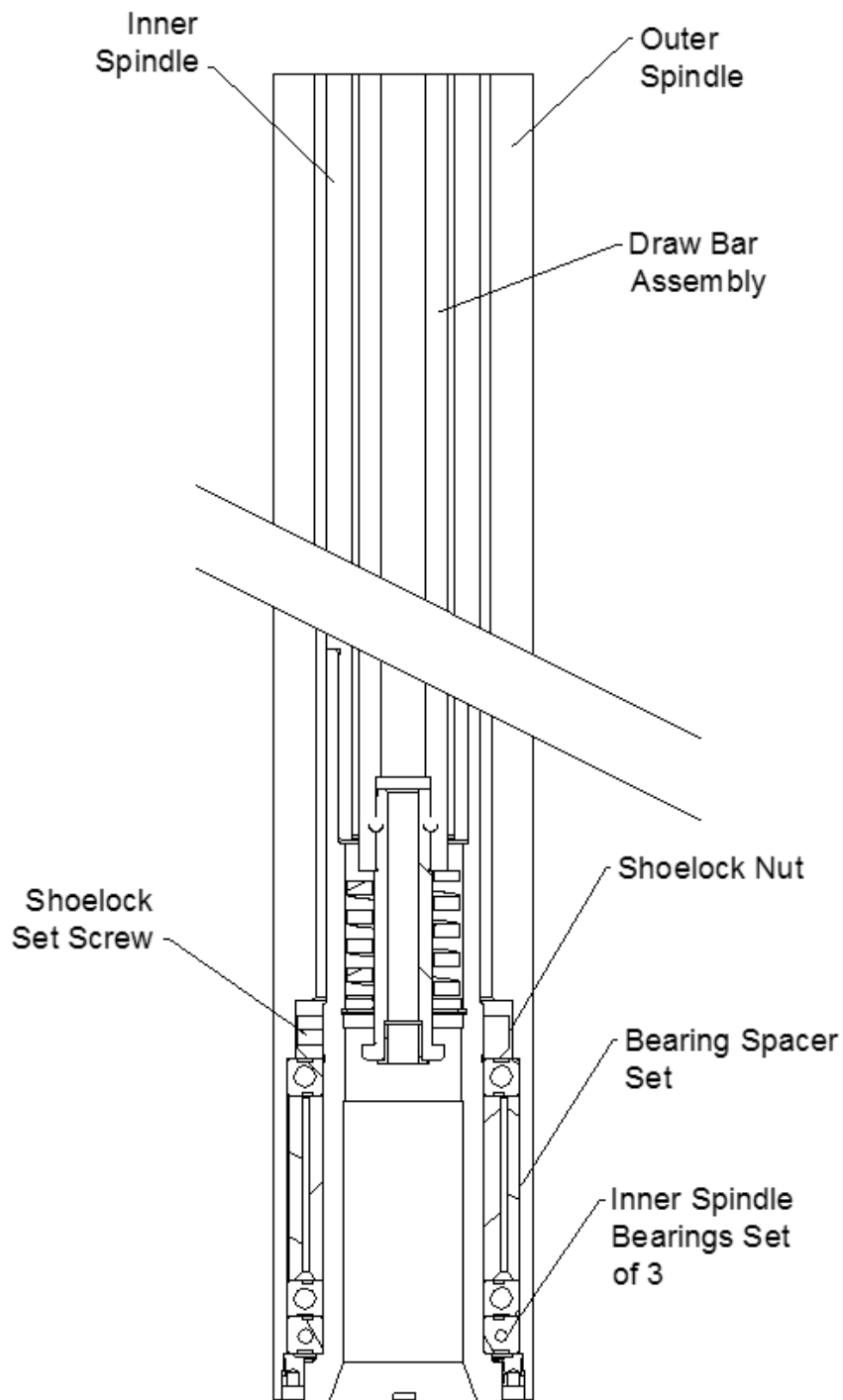

## Spindle Sweep

The outer spindle must be swept into the main bed of the machine to achieve accurate bores.

Remove all fixturing from the machine bed, clean and stone if needed.

Install a boring cutterhead into the machine.

Install the sweep are into the cutterhead.

Bring the machine down until you have about .005" pressure on the indicator.

**CAUTION** Disconnect all power and air to the machine before continuing, severe bodily injury may occur.

Turn the sweep arm to the 9 O'clock position. Zero the indicator here.

Loosen the 6 socket head cap screws on the lower spindle hub. You do not want them all the way loose, just snug.

Use the four (4) set screws in the spindle base to move the spindle until the indicator reads within .0005" with a full 360 degree sweep of the indicator.

**Note:** *You do not want the right hand side of the spindle to be more positive than the left, it will interfere with the automatic tilt of the machine when in Mill mode.*

Once the spindle is swept in tighten the six (6) socket head cap screws and double check that the sweep did not move.

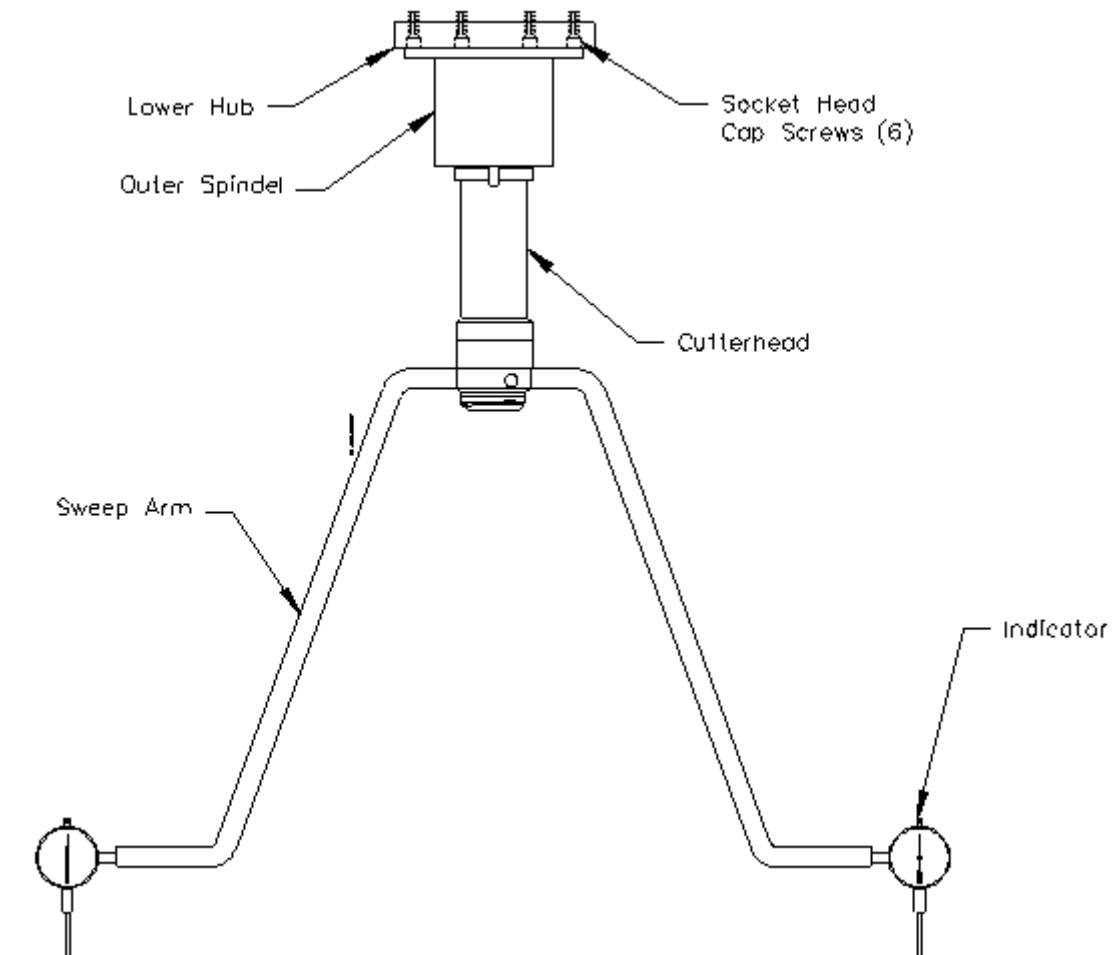

## Adjusting Y-Axis Gibs

The Y-Axis adjusting gibs are located at the top of the machine column that the spindle base is mounted on. There are gibs located on the top and side rails on the left side of the column. Two are located on the top rail and two are located on the side rail.

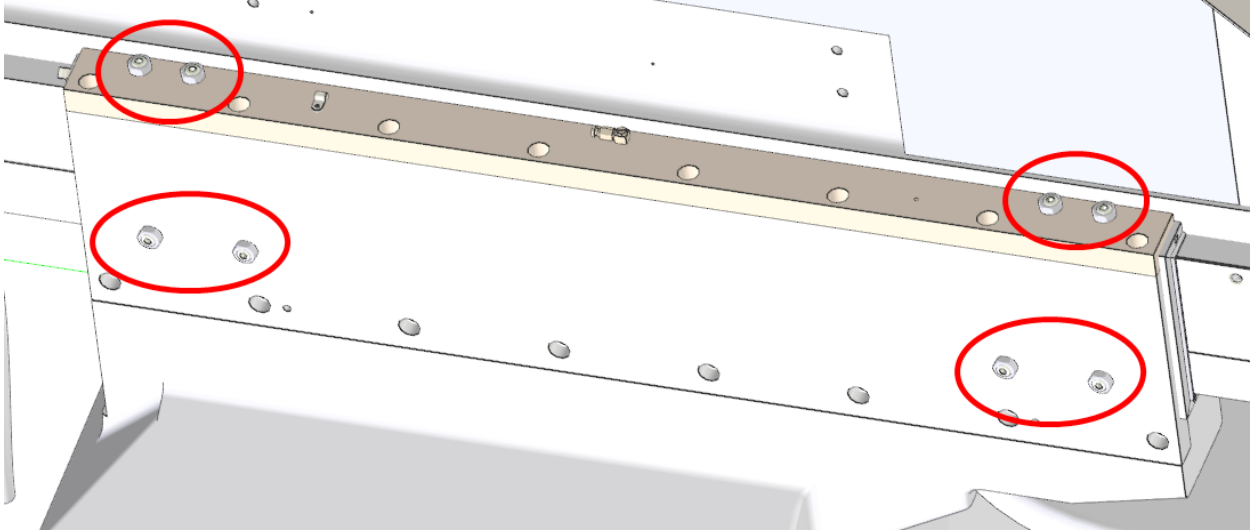

On the right side of the column there are gibs located on the top rail.

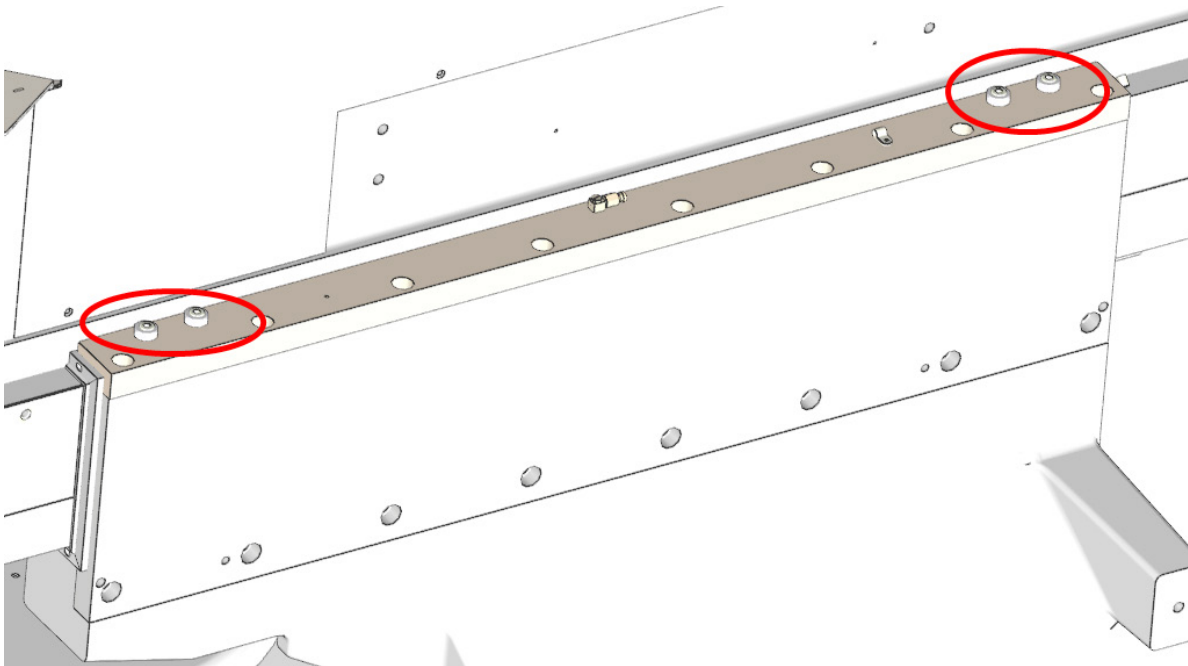

**Adjustment Procedure**

1. On the left side rail loosen the jam nuts.
2. Tighten the set screws until they bottom out and can't be turned further.
3. Loosen each set screw 1/8 turn.
4. Tighten jam nuts.
5. On both top rails loosen jam nuts.
6. Tighten the set screws until they bottom out and can't be turned further.
7. Loosen each set screw 3/4 turn.
8. Tighten jam nuts.

## Backlash Setting .NET Software

The Screens depicted below are for setting **Backlash** compensation values only. **DO NOT** use any other information on these screens to change information on the machine.

1. Turn off "Overshoot Backlash Setup"

**Note:** Only the F70-90 and 100 machines use the overshoot feature.

Go to Setup Software>Addins>Overshoot Backlash Setup

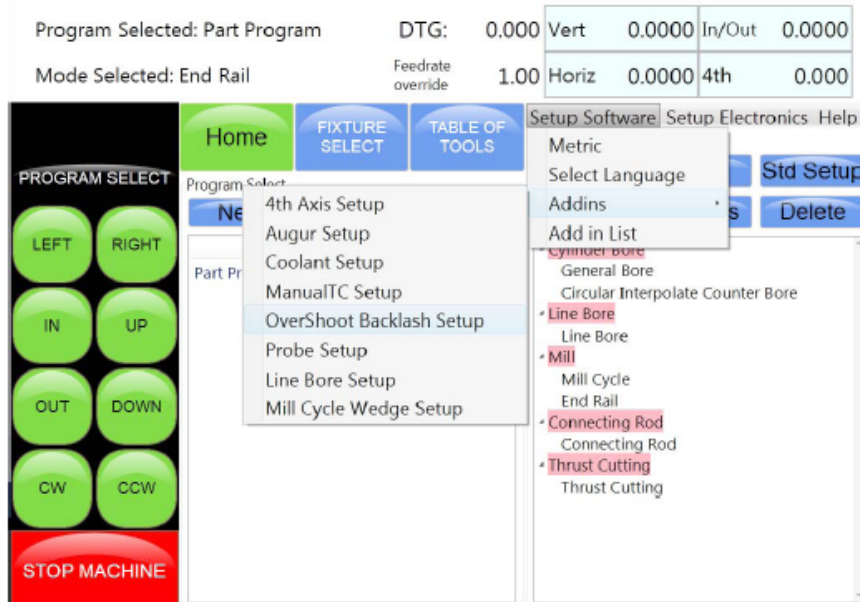

The Following screen will appear.

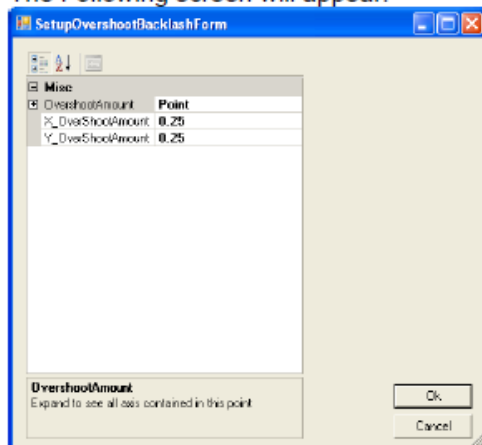

1. Record the existing X and Y "Overshoot Amount". Generally .250
2. Use the "On Screen Keyboard", or plug in the full size keyboard, and change the amounts to 0.00, and click on OK. Close the "Setup" screen.

3. Go to Setup Electronics>Control

Program Selected: Part Program      DTG: 0.000      Vert 0.0000      In/Out 0.0000

Mode Selected: End Rail      Feedrate override 1.00      Horiz 0.0000      4th 0.000

The screenshot shows a CNC control interface. On the left is a 'PROGRAM SELECT' panel with buttons for LEFT, RIGHT, IN, UP, OUT, DOWN, CW, and CCW, and a red 'STOP MACHINE' button. In the center is a 'Control Options' dialog box with a table of ControlOptionsForm and LinkNumber values. On the right is a 'Setup Software' menu with 'Setup Electronics' selected, showing a 'Control' submenu with options like Coordinated Motion and IO. Below the menu is a list of tool types including Cylinder Bore, Line Bore, Mill, Connecting Rod, and Thrust Cutting.

ControlOptionsForm	LinkNumber
X	0
Y	1
Z	2
Handwheel	-1
S	3
A	-1
Outputs	6
Inputs	5

Control Options

Setup Software Setup Electronics Help

Mode Select Control

Select Coordinated Motion IO

- Cylinder Bore
  - General Bore
  - Circular Interpolate Counter Bore
- Line Bore
  - Line Bore
- Mill
  - Mill Cycle
  - End Rail
- Connecting Rod
  - Connecting Rod
- Thrust Cutting
  - Thrust Cutting

4. On the "Control Options" screen, double click the X to bring up the "X Options" screen.

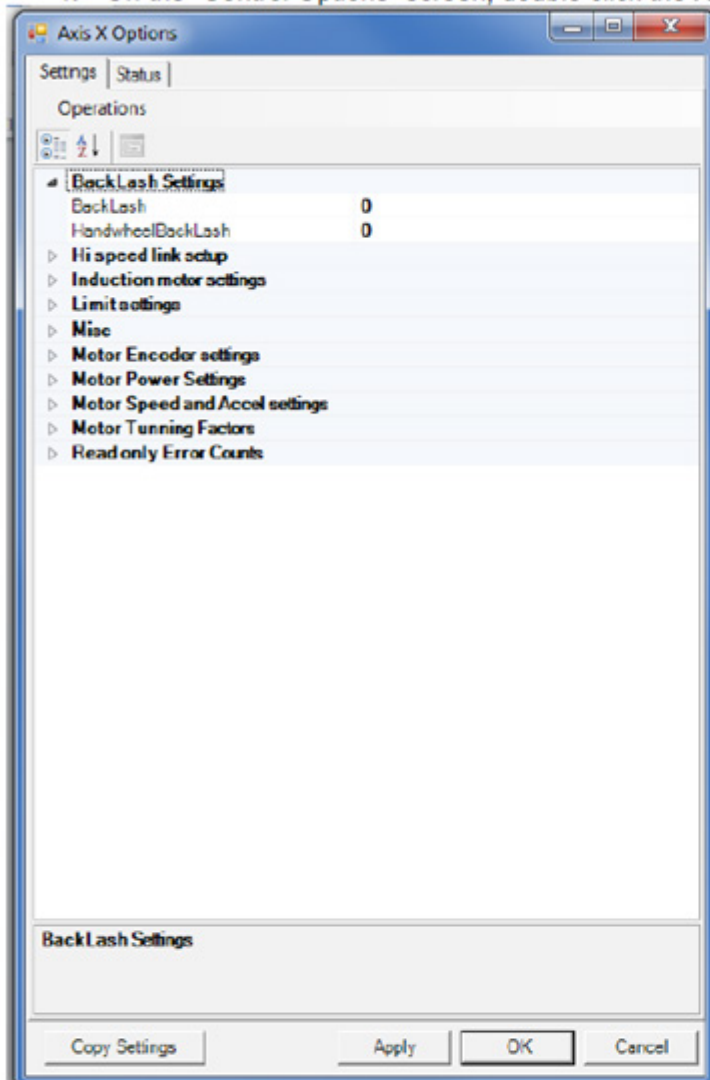

Now minimize the screen.

5. Repeat step 4 for the Y and Z axis.
6. Close the "Control Options" screen.



7. Select a program (block), then select any cylinder bore mode.

The screenshot displays the Rottler Back Boring control interface. At the top, it shows 'Program Selected: test' and 'Mode Selected: General Bore'. Below this, there are fields for 'DTG: 0.000', 'Feedrate override: 1.00', and a table for 'Vert 0.0000 In/Out 0.0000' and 'Horiz 0.0000 4th 0.000'. The main interface is divided into several sections: 'Set Zeros' with buttons for VERTICAL, HORIZONTAL, IN/OUT, and SPINDLE; 'Vertical Stops' with 'Actual Position' values of 0.0000 for VERTICAL, HORIZONTAL, and IN/OUT, and 0.00 for SPINDLE; and 'Locations' with 'Handwheel' buttons (.010, .001, .0001) and 'Move To' buttons. A 'STOP MACHINE' button is prominent in red. Other buttons include 'PROGRAM SELECT', 'LEFT', 'RIGHT', 'IN', 'UP', 'OUT', 'DOWN', 'CW', 'CCW', 'MOVE TO ZEROS', 'CW INDEX', 'CCW INDEX', and 'START SPINDLE'. Status indicators for 'Spindle Load 0.0%', 'Feed Rate 0.0020', and 'Spindle RPM 400' are also visible.

**Notes:**

\*\*\*The photos shown are demonstrating the X axis (horizontal) backlash adjustment. The Y and Z axis are adjusted following the same steps.

\*\*\*The direction of machine travel to put the initial load on the dial indicator, are as follows:

X (horizontal), from the right toward the left.

Y (in/out), from back toward the front.

Z (vertical) from top toward the bottom.

A Dial Indicator with 1.0" to 1.5" of travel should be used for several reasons.



If the axis is overshooting or coming to position slowly you will be able to see it with a dial indicator. With Digital indicator you will only see the end position. The Magnascale indicator should be used to dial or tram in. The automatic moves of the machine can "Shock" the sensitive plunger of the Magnascale.

8. Attach the magnetic base and dial indicator to a stationary stand, parallel, or engine block fixed to the machine bed.

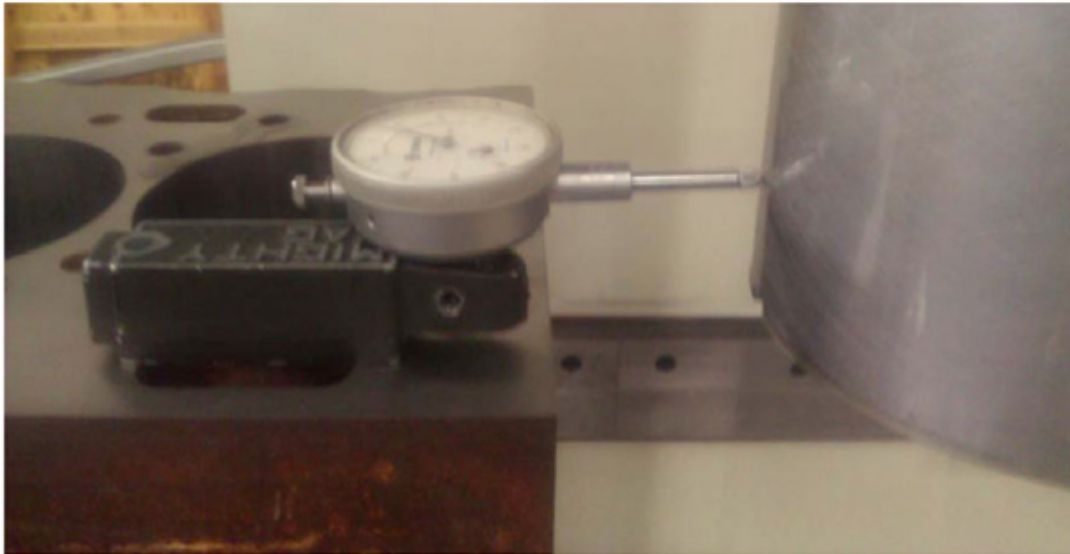

9. Bring the spindle of the machine in position to put a slight load on the Plunger, about .020".

10. Set "Vertical, Horizontal, In/Out" zero.

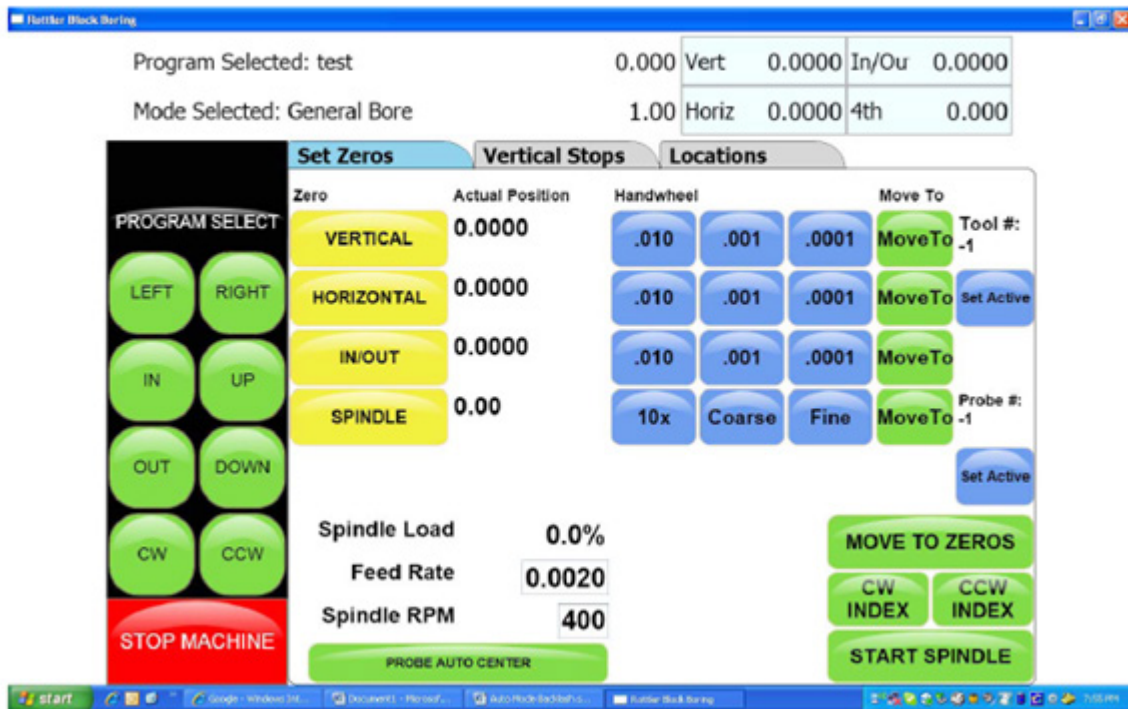

11. Set all vertical stops to "zero".



12. Move the machine spindle away from the Plunger a few inches, and press "Move to" and then 0 and Enter from the pop up keypad for the axis that is being measured..

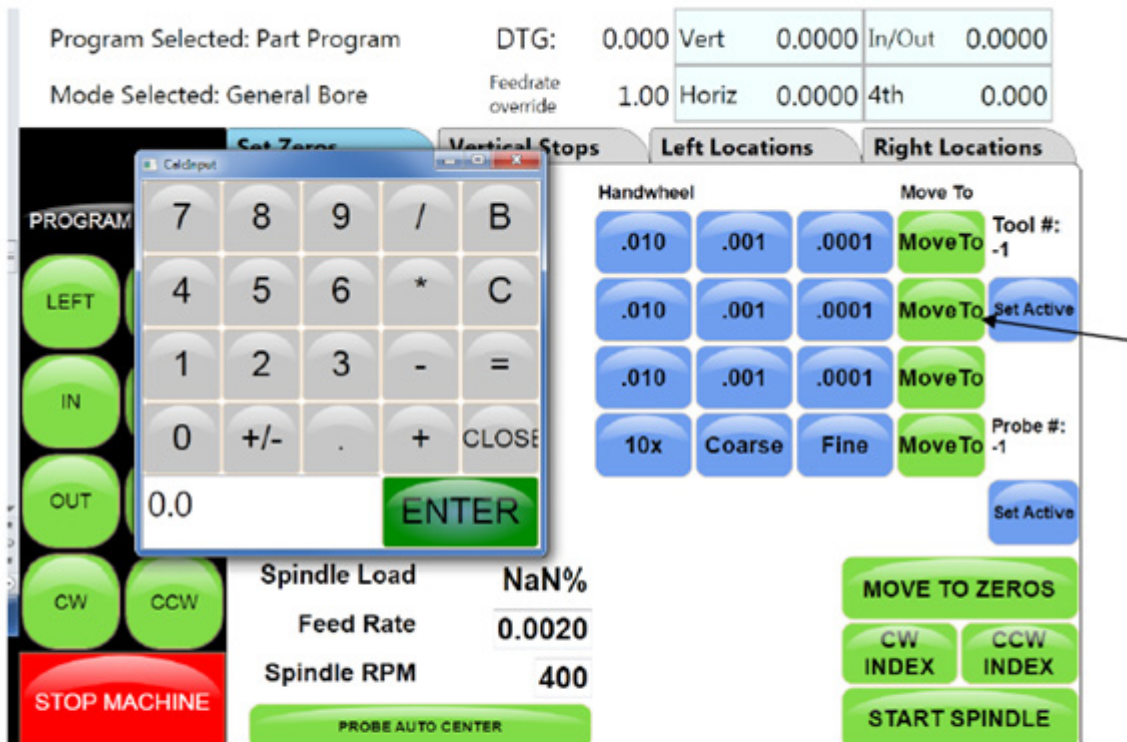

13. Repeat the movement to verify the machine will repeatedly position itself at zero.  
 14. Now, use the "Move To" button and then -.200 to move the spindle -.200" in the opposite direction.  
 15. Press "Move to" and then 0 and Enter from the pop up keypad for the axis that is being measured..

If the machine did not position itself to bring the digital readout to zero, a backlash compensation adjustment is needed.



16. To adjust, maximize the "Axis X Options" screen. Go to Backlash Setting>Backlash.

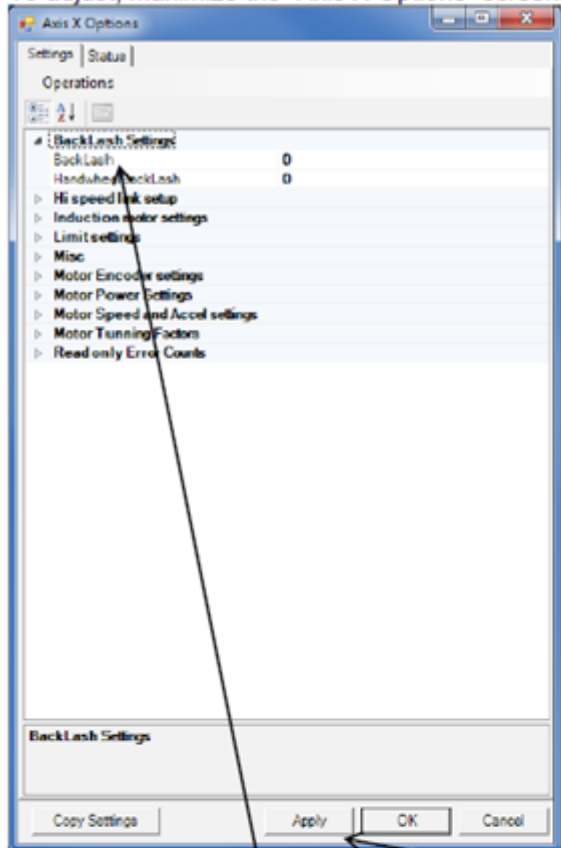

17. Use the "On Screen Keyboard", or plug in the full size keyboard to enter the amount of correction in the Backlash area. After entering a value, click "Apply", for the new setting to take effect.
18. Repeat steps 13 through 17 and adjust as necessary until the machine positions itself to "Zero" on the digital readout from both directions.

Handwheel Backlash is measured in a similar way to Backlash but the axes is moved by the Handwheel – the Move To buttons are NOT used.

19. Set up the Dial Indicator as described in #8 and #9.
20. Touch the .001" Handwheel button and move the axis to away. Turn the handwheel at a **constant speed** and move the axis back until the control panel displays zero. If the axis travels past zero, start again - move back again and turn the Handwheel at **constant speed** until the axis stops on zero on the machine display. Check that the Dial Indicator is zero, if not, move away and back again until both the machine control and Dial Indicator both read zero.

21. Now move the axis in the opposite direction and be sure to stop about .020" less that total plunger travel before compressing the plunger all the way. Now move the axis back by turning the Handwheel at a **constant speed** until the machine display reads zero. Check the reading on the Dial Indicator.
22. Use the "On Screen Keyboard", or plug in the full size keyboard to enter the amount of correction into Handwheel Backlash. Press Apply when you are done.

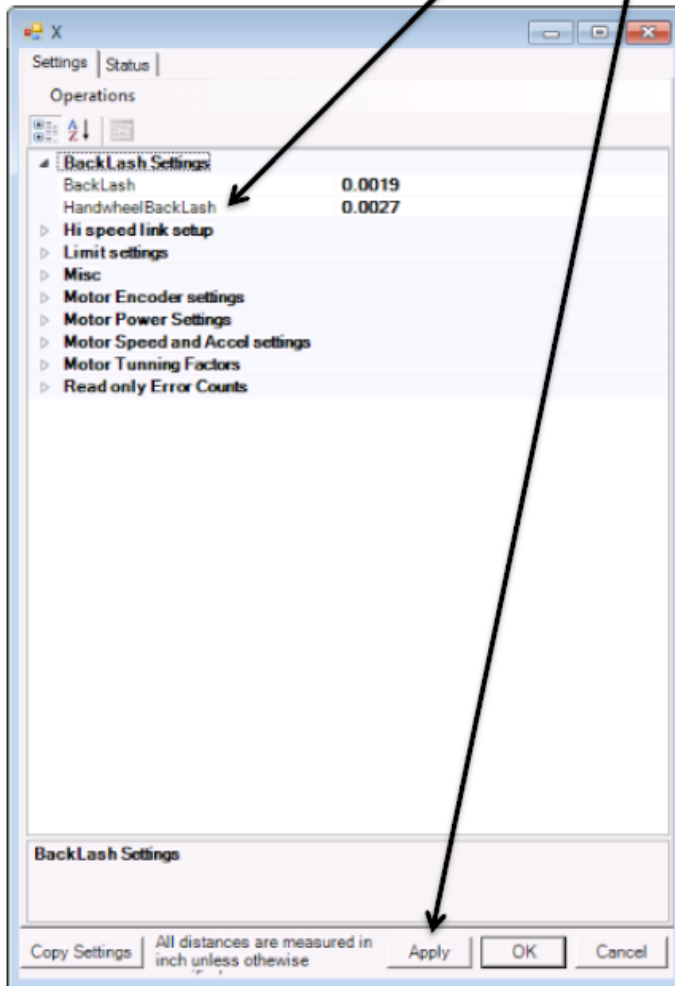

23. Follow steps 9 through 22 for the Y and Z axis.
24. When finished, re-enter the "Overshoot Backlash Amounts", as recorded in step 2 and click OK and close the window.

## Spindle Drive Belt Replacement / Adjustment

**CAUTION** Turn off power to machine before proceeding with this procedure.

The spindle drive belt is located in the upper spindle housing.

Remove the spindle door and covers.

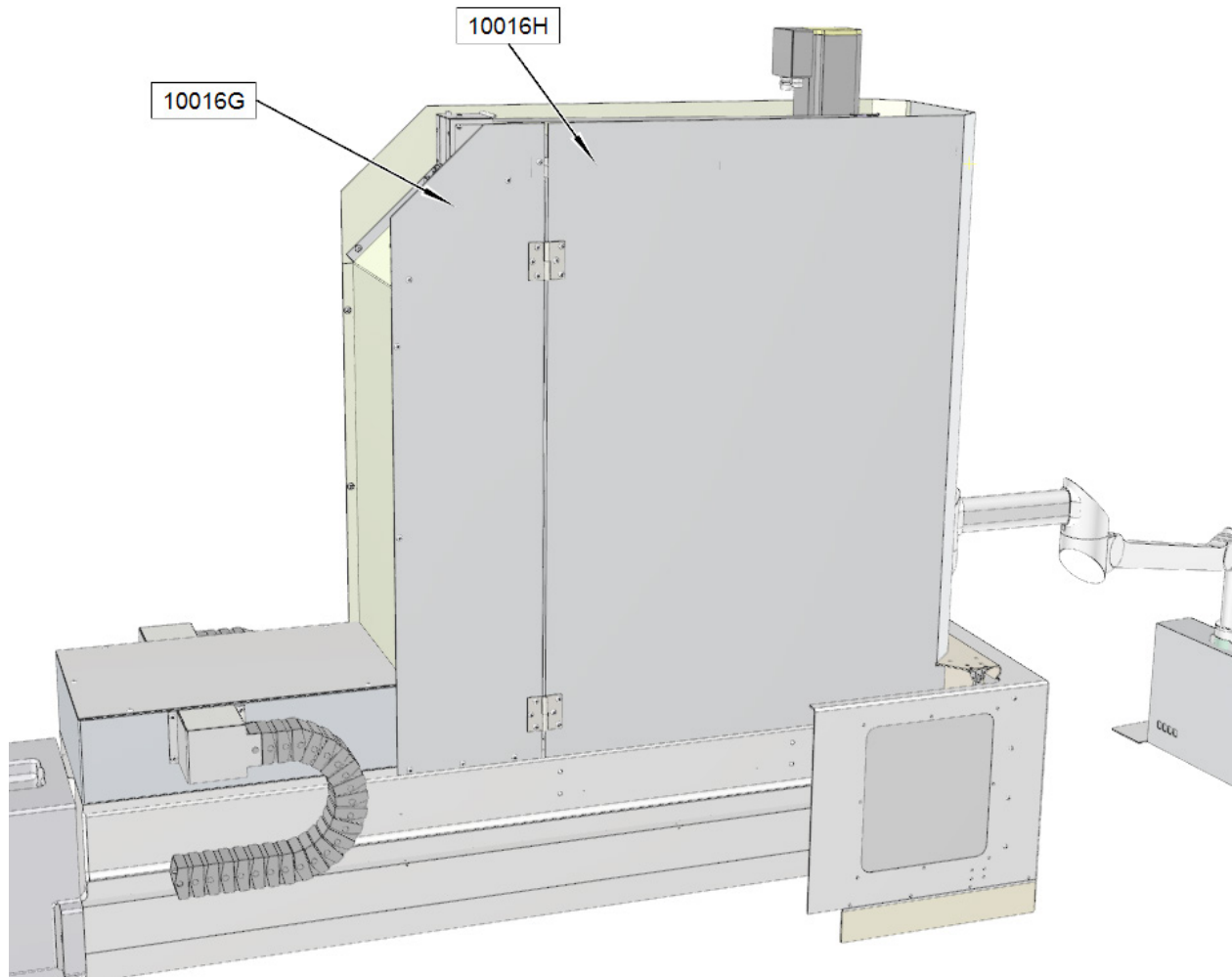

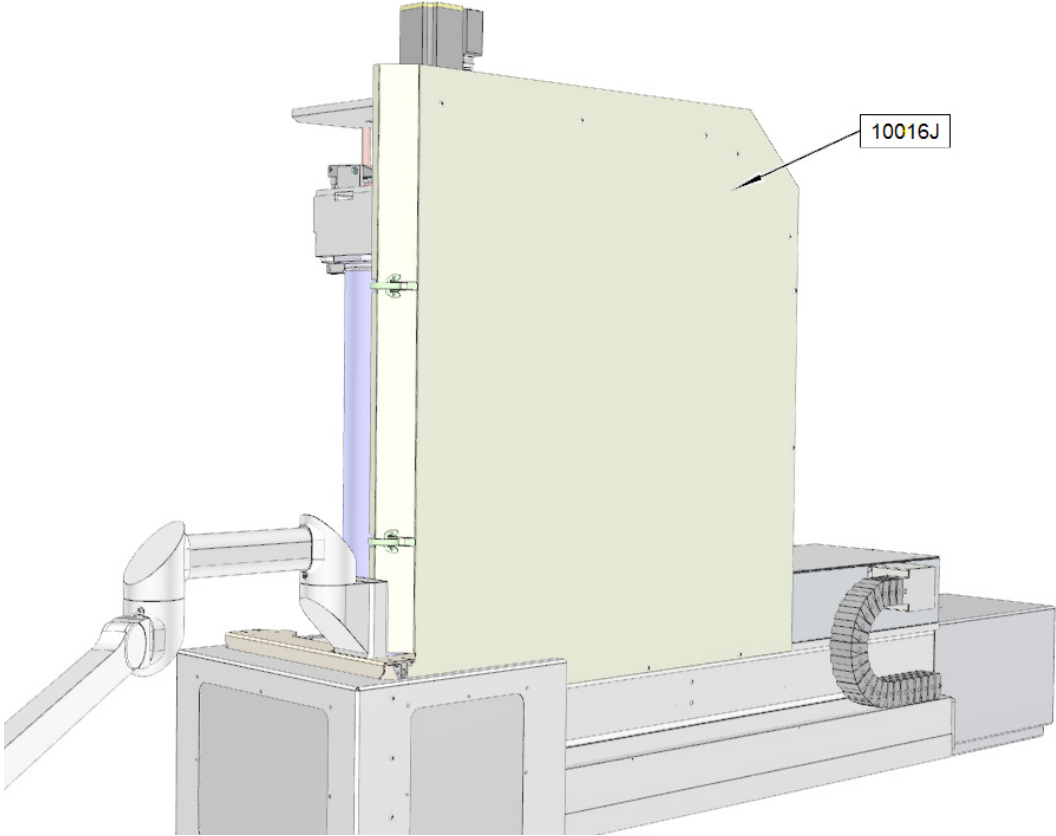

Lower spindle down onto a piece of wood to prevent the motor from falling.





Remove the counter weight cable end from the upper housing.

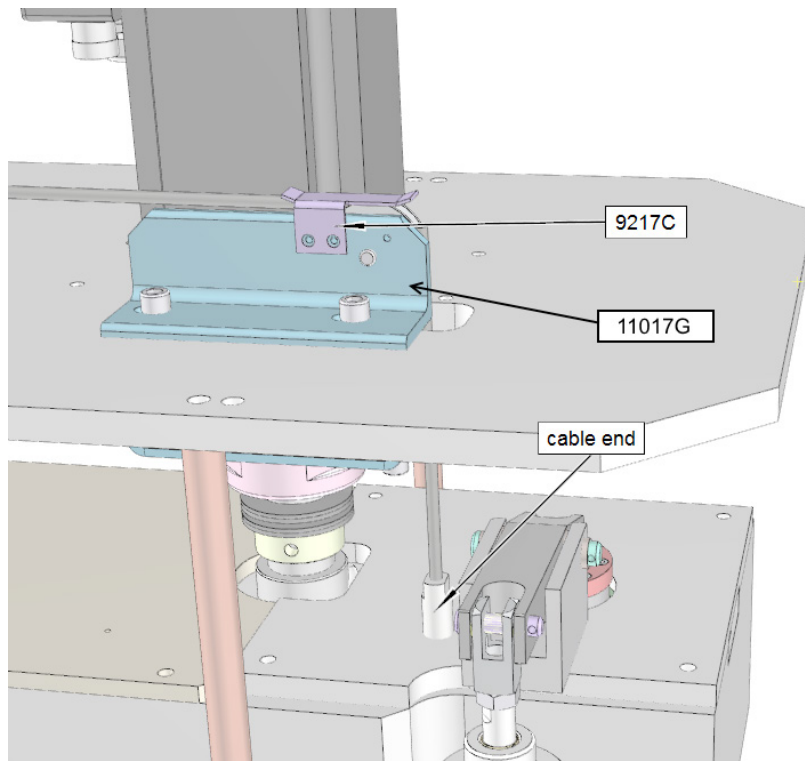

Remove Z-Axis motor, mount plate, and bracket.

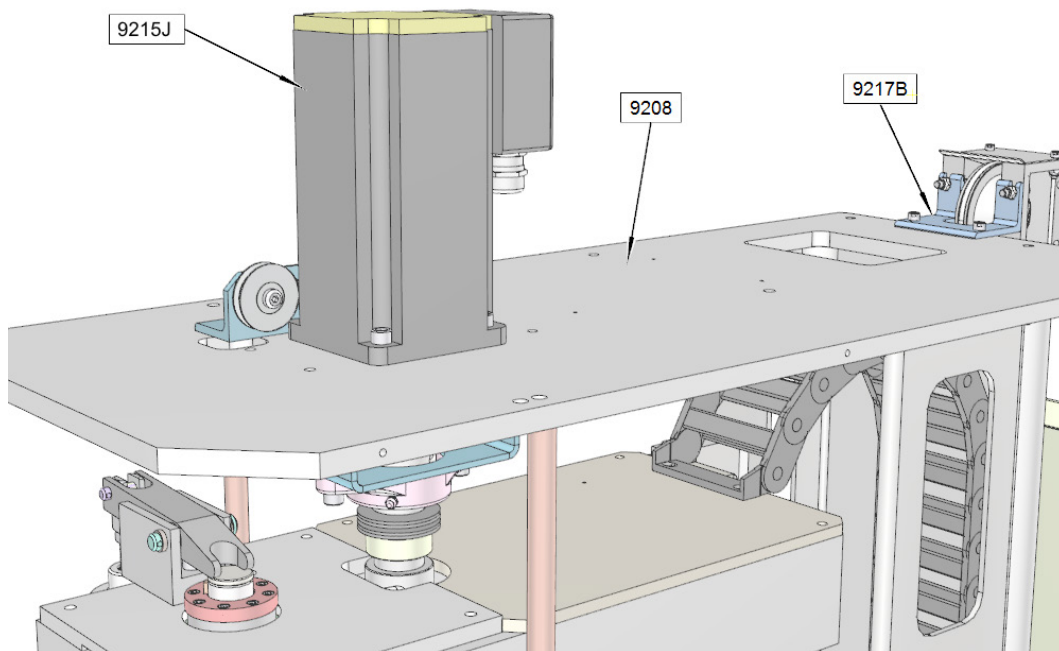

Remove drawbar bracket assembly and front housing cover plate.

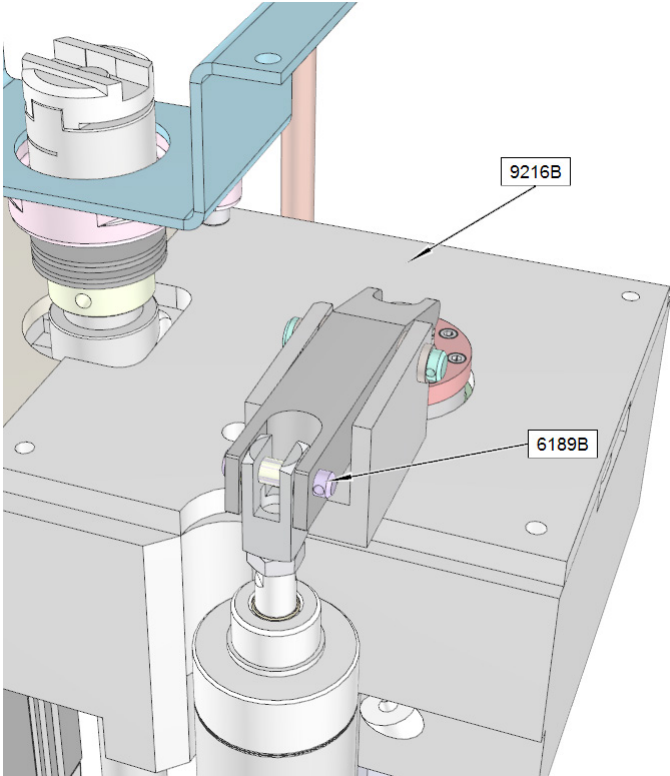

Remove rear housing cover plate.

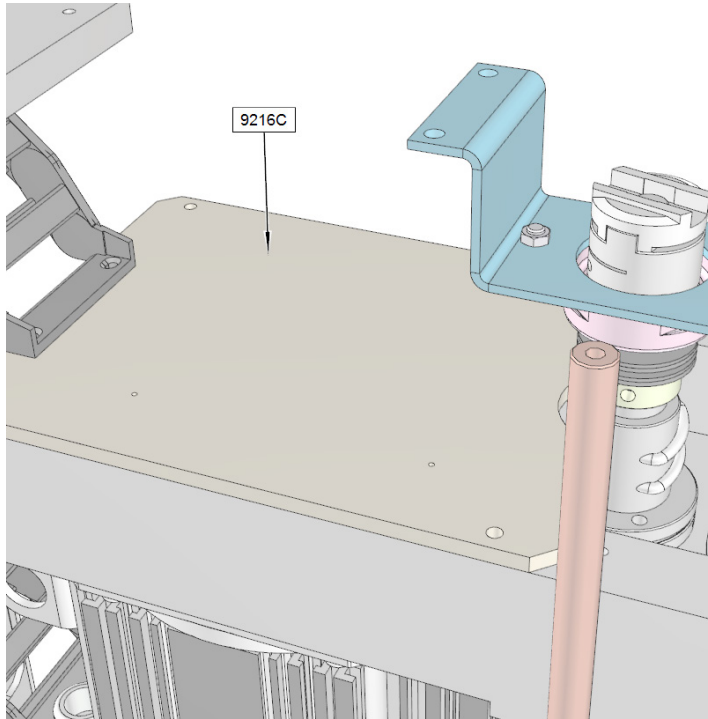

Loosen motor mount bolts and belt tension adjusting bolt.

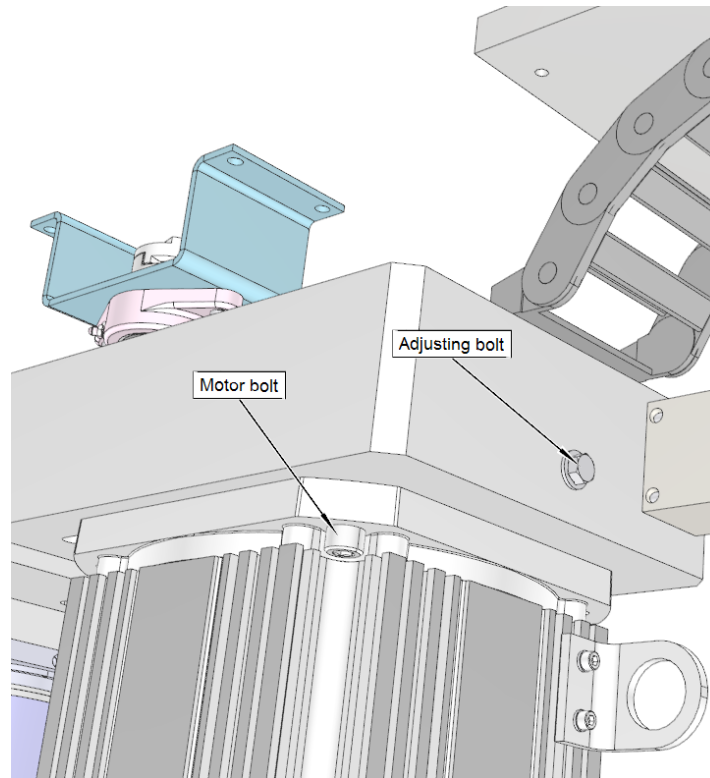

Remove and replace bolt.

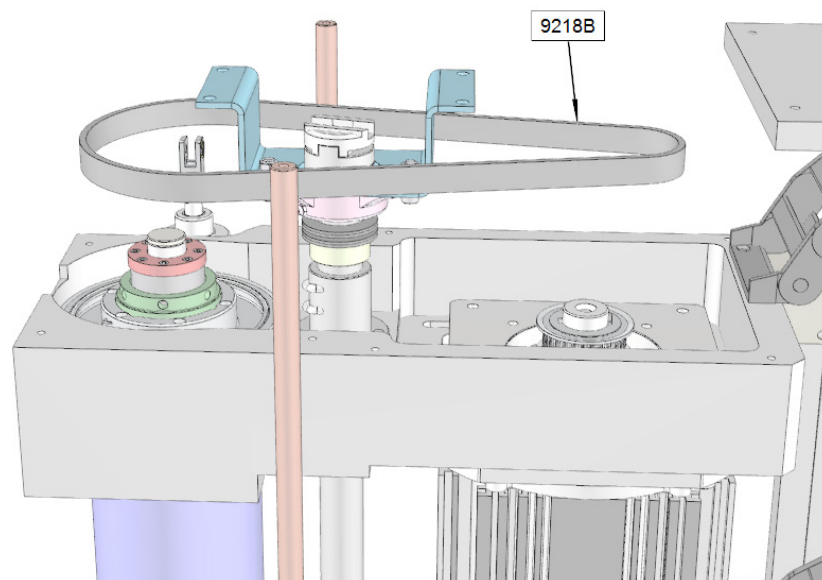

When the new belt is in place use the adjusting bolt to set the belt tension. Proper tension is when there is 5/16" of deflection when 2-4 lbs. of force is applied between the 2 pulleys.

### Mill Tilt Adjustment Procedure

1. Position the Y axis in the middle of its travel. Using a 5/32" hex key, loosen the locking set screw through the access hole in the right side guide rail



2. Put the machine in "Mill Cycle" mode, with the wedge turned off. Attach an indicator as shown in the following photo, and set to zero position.





3. Using a 3/16" hex key, turn the adjustment screw in or out to increase, or decrease, the amount of mill tilt. Turn the screw CCW to increase, or turn CW to decrease the amount as shown in the photo at step #2. After each adjustment, turn the "Wedge On", to check the amount. Set to .002" - .004" (.05mm - .1mm) of lift with the wedge turned on. Turn the wedge off to readjust, and then turn the wedge on to check the amount.
4. When finished, tighten the locking set screw as shown in the photo in step #1.
5. Repeat the procedure for the rear wedge.



6. After adjusting the rear wedge, re-check the front, to make sure it did not change.

### Checking Wear on Column Turcite Pads

Remove bolts holding way covers to column.

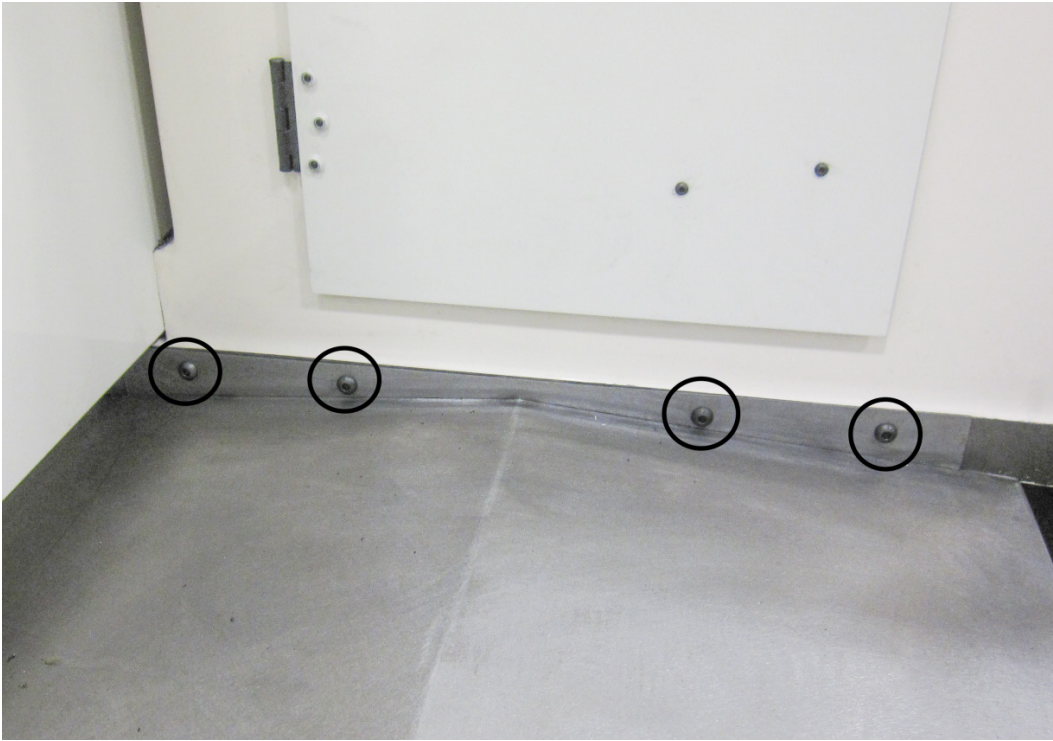

Slide way covers away from column to gain access to column way.  
Remove wipers from Turcite pads.

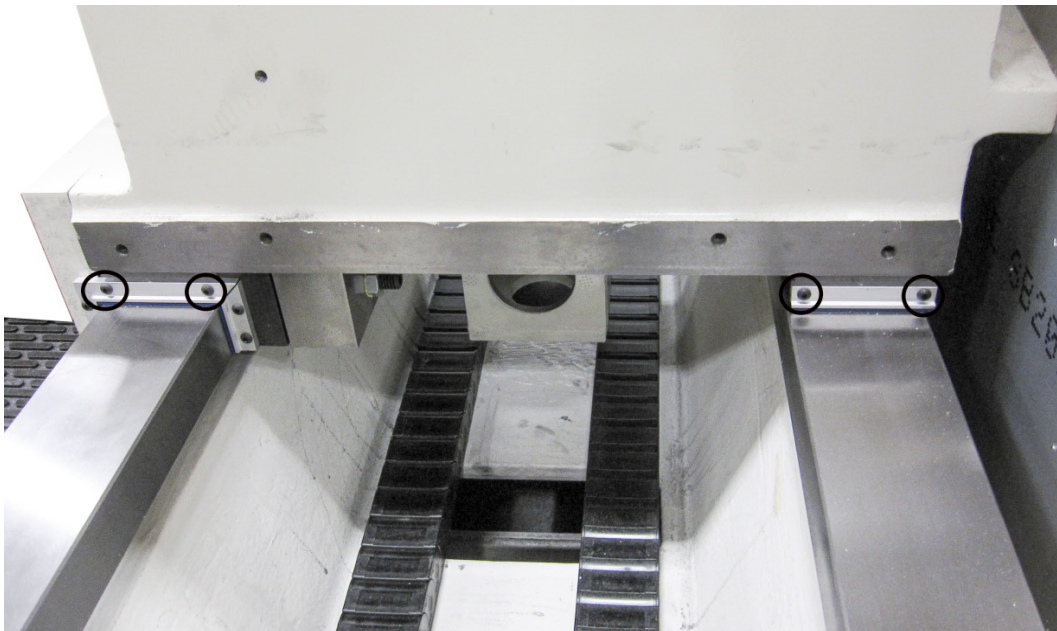

Measure height of Turcite pads using either feeler gauge or dial indicator method.

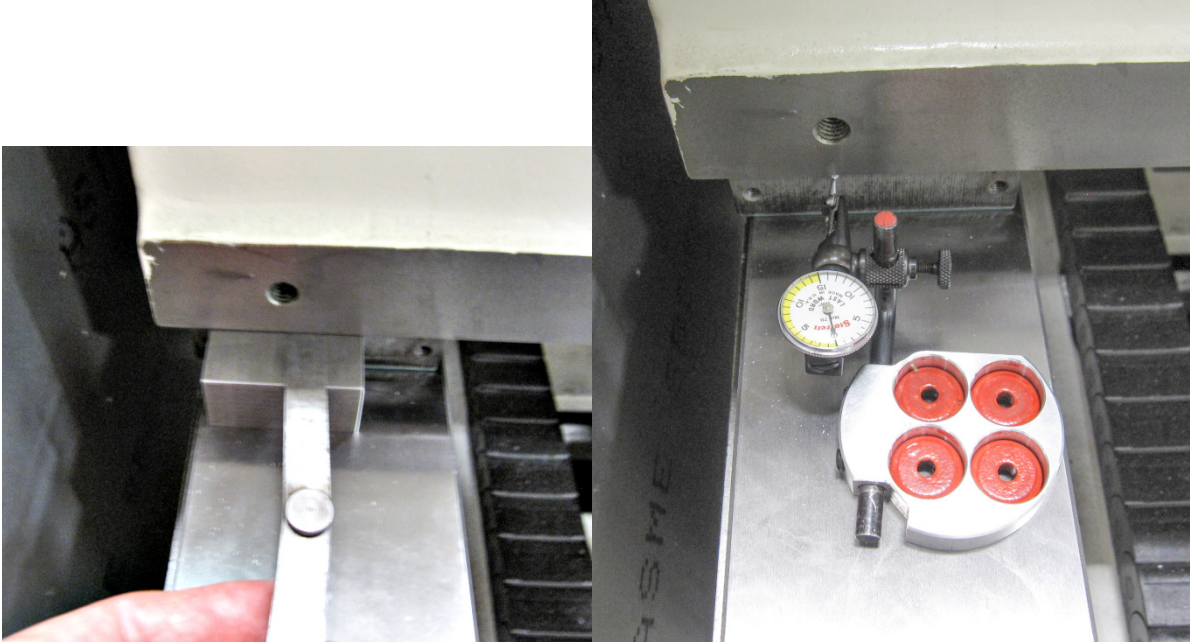

Pads will have to be replaced or shimmed if height difference between the 4 pads exceeds .005".

**Preventative Maintenance Quick Reference Chart**

Refer to the procedures above to make or check these adjustments. Not all of the items listed in the table below have adjustment. The information should be recorded and the amount of wear tracked so the part can be replaced before down time on the machine occurs.

<b>Procedure</b>	<b>Frequency</b>
Inner Spindle	1000 Hours
Outer Spindle	500 Hours
Horizontal Gibs	2000 Hours
Vertical Belt	1000 Hours
Spindle Belt	1000 Hours
Spindle Sweep	150 Hours
Horizontal Ballscrew	2000 Hours
Horizontal Backlash	1000 Hours
Vertical Backlash	1000 Hours
In/Out Backlash	1000 Hours
Spindle Tilt	500 Hours
Machine Level	1000 Hours
Spindle Wear	2000 Hours
Horizontal Way Wear	2000 Hours



## Digital Micrometer setting instructions

Turn the thimble until the '0' line on the thimble lines up with the vertical line nearest the spindle lock ring.



Determine which cutter head bore range the micrometer is going to be used on. ( example; 2.9 – 6.0 )  
We want to initially set the micrometer to the minimum bore diameter of this cutterhead.

**NOTE: MICROMETER CAN NOT BE PROGRAMMED IF THE LETTERS INC APPEAR IN THE DISPLAY.** To get rid of INC, quickly press the in/mm/ABS button.

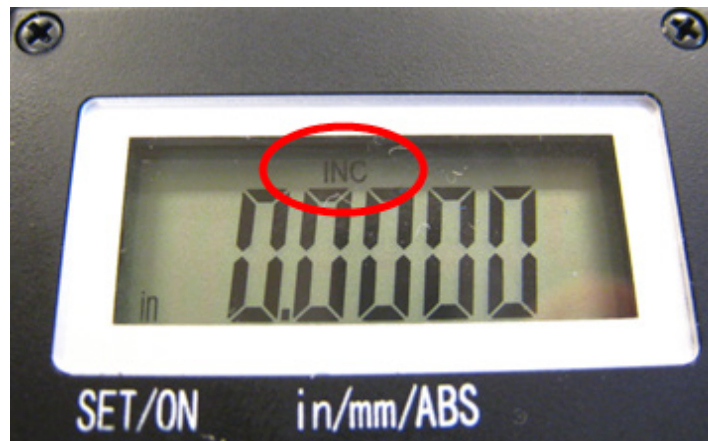

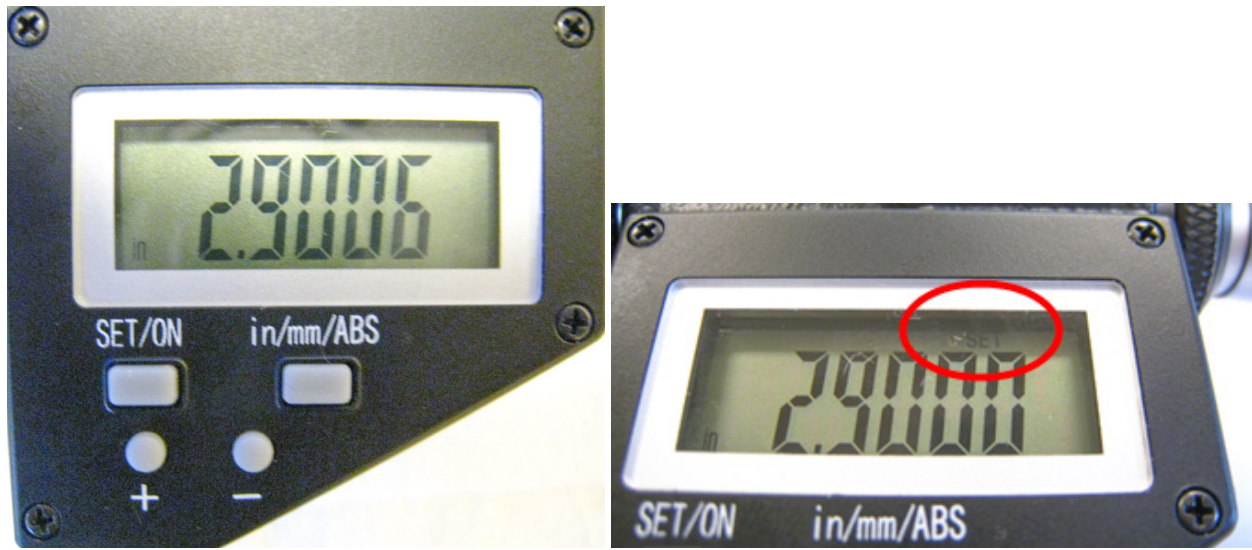
**To set or edit micrometer**

Press and hold the set/on button and the + or – button at the same time. “Set” will flash in the display. This places the micrometer in edit mode. (CAUTION: use a pencil tip or something similar to gently push the small round buttons - they are quite small and a bit delicate.)

Press and hold the + or – buttons to change the display number to the minimum bore diameter determined earlier (example; 2.9). Caution: Pushing the + or – buttons and holding in place will cause the numbers to scroll automatically. The numbers will count slowly at first and once 0.010” has been counted off the scrolling speed will pick dramatically.

After you have reached the desired number in the display, press the set/on button twice quickly to exit the edit mode. “Set” should no longer be flashing in the display. The micrometer is now ready for use.

CAUTION: AFTER MICROMETER SET-UP IS COMPLETE, DO NOT PUSH SET/ON BUTTON AGAIN. PUSHING THE SET/ON BUTTON DURING USE WILL RETURN THE DISPLAY TO THE ORIGINAL MINIMUM BORE DIAMETER. THE ONLY TIME YOU SHOULD USE THE SET/ON BUTTON AGAIN IS TO- A. To shut micrometer off at which time you push and hold the button or B. to turn micrometer display back on at which time you push button one time. The display will then show the last reading before micrometer was shut off.

CAUTION: DO NOT BACK THE THIMBLE ALL THE WAY OUT TO THE END OF IT’S TRAVEL. ONCE THE THIMBLE IS BACKED ALL THE WAY OUT, IT WILL NO LONGER ROTATE PROPERLY AND THE DIGITAL HEAD WILL NEED TO BE REPLACED.

Micrometer is calibrated in inch mode. If metric is desired, press and hold in/mm/ABS button until mode changes to metric (approximately 3-4 seconds). A quick press of the in/mm/ABS button will put micrometer in ABS mode: 0.000, with another quick press returning it to initial setting.

Set up the cutter head and bore a set up hole. Measure the bore accurately. Set the digital display to this bore dimension and then -

Loosen the set screw holding the large diameter anvil. Slide the anvil back out of the way.



Place the tool holder used to bore the hole into the micrometer frame. Slide the location nub on the back of the tool holder gently up against the end of the digital micrometer shaft.

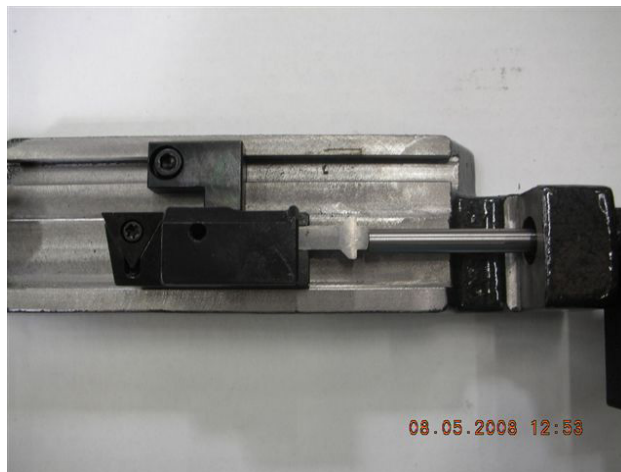

Slide the large diameter anvil up until it touches the end of the cutting tip of the tool holder. Tighten the set screw.



Back the digital micrometer shaft off, then bring it up to touch the tool holder and recheck that the numbers in the display are the same as the numbers previously shown.



The micrometer is now set up for use with this cutter head.

Note: this procedure must be repeated to set the micrometer to a different cutter head. The micrometer can only be set to one cutter head at a time.

To shut off micrometer press and hold set/on button until screen goes blank or let micrometer set until display disappears.

With initial setting of micrometer it is recommended that you use the procedure detailed below in the event you think you have size problems.



**Procedure:**

The short vertical lines that cross the horizontal scale on the micrometer sleeve are reference marks. Set the zero on the micrometer thimble even with the first vertical line and note the size shown in the digital display. Record this size for future reference. Now follow the same procedure for each line and record the sizes. At any time you feel your micrometer is reading incorrectly, you can quickly refer to the recorded size of the line closest to the range you are using and check that the micrometer is still accurate.







## Probe “On-Center” Adjustment

This covers setup and calibration of the probe, so it will accurately position your machine.

- Verify that the four adjusting screws and two locking screws are installed in the probe tool holder.
- Assemble probe on either CAT 40 Shank or Rottler Taper
- With the machine breaker that supplies power to the probe receiver turned off;
- Install batteries in the probe WITH stylus deflected.

Probe LED check will run.

- Release stylus after battery check this will put you in edit mode.
- First will be Switch off method, you want this at **purple, purple, yellow** (Radio On). If it is not, deflect and release stylus quickly to change the mode.
- Hold the stylus deflected until the colors change to move to the next setting.
- You should be at Switch Off method; it should be **red, red, yellow** (134 seconds). If it is not, deflect and release stylus quickly to change the mode.
- Hold the stylus deflected until the colors change to move to the next setting.
- You should be at Enhanced trigger filter; it should be **green, green, green** (on). If it is not, deflect and release stylus quickly to change the mode.
- Hold the stylus deflected until the colors change again to move to the next setting.
- You should be at Acquisition mode, **light blue, light blue, light blue**.
- Turn on machine and quickly deflect and release the stylus. This must be done within 10 seconds of turning on the power breaker to the probe. If you are watching the RMI-Q (located ON the machine) you will see the right light turn **red, yellow, red, yellow, red, yellow** is shows the partnership has been acquired.
- Go into the software and do a probe auto center and hit start probe to verify that it works correctly.

Key to the symbols	
	LED short flash
	LED long flash
	Deflect the stylus for less than 4 seconds to move to the next menu option.
	Deflect the stylus for more than 4 seconds to move to the next menu.
	To exit, leave the stylus untouched for more than 20 seconds.

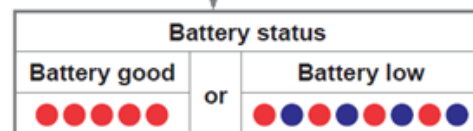
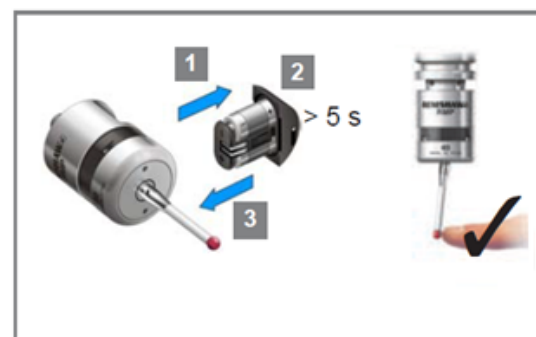

Switch on method, next page

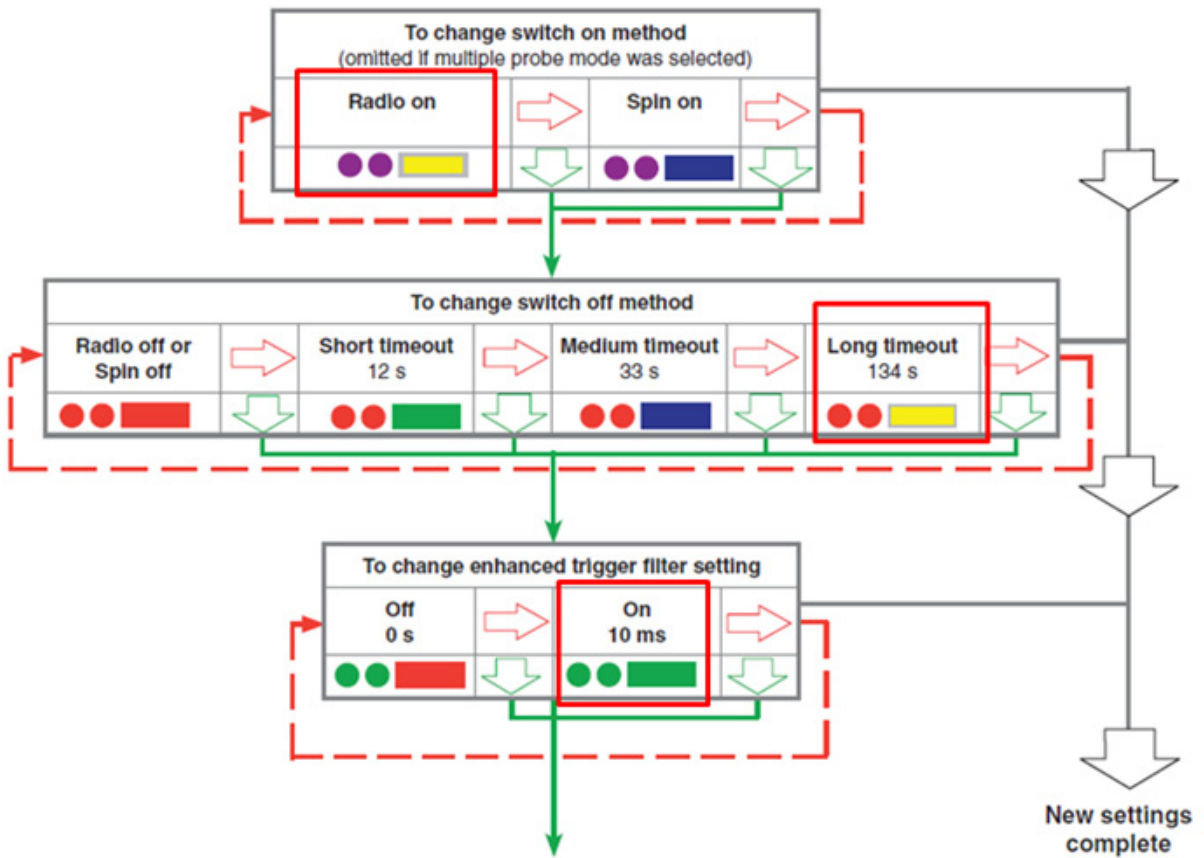

**Changing the probe settings (continued)**

**Note:** After the RMI has been acquired, the RMP40 will only show Acquisition mode off.

See RMP40 - RMI partnership.

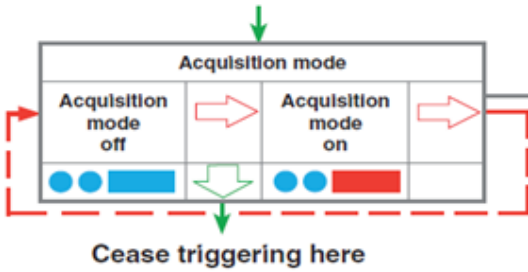

If the Probe does not turn off after 137 seconds you will need to make sure that the RMI-Q switches are shown in the following positions:

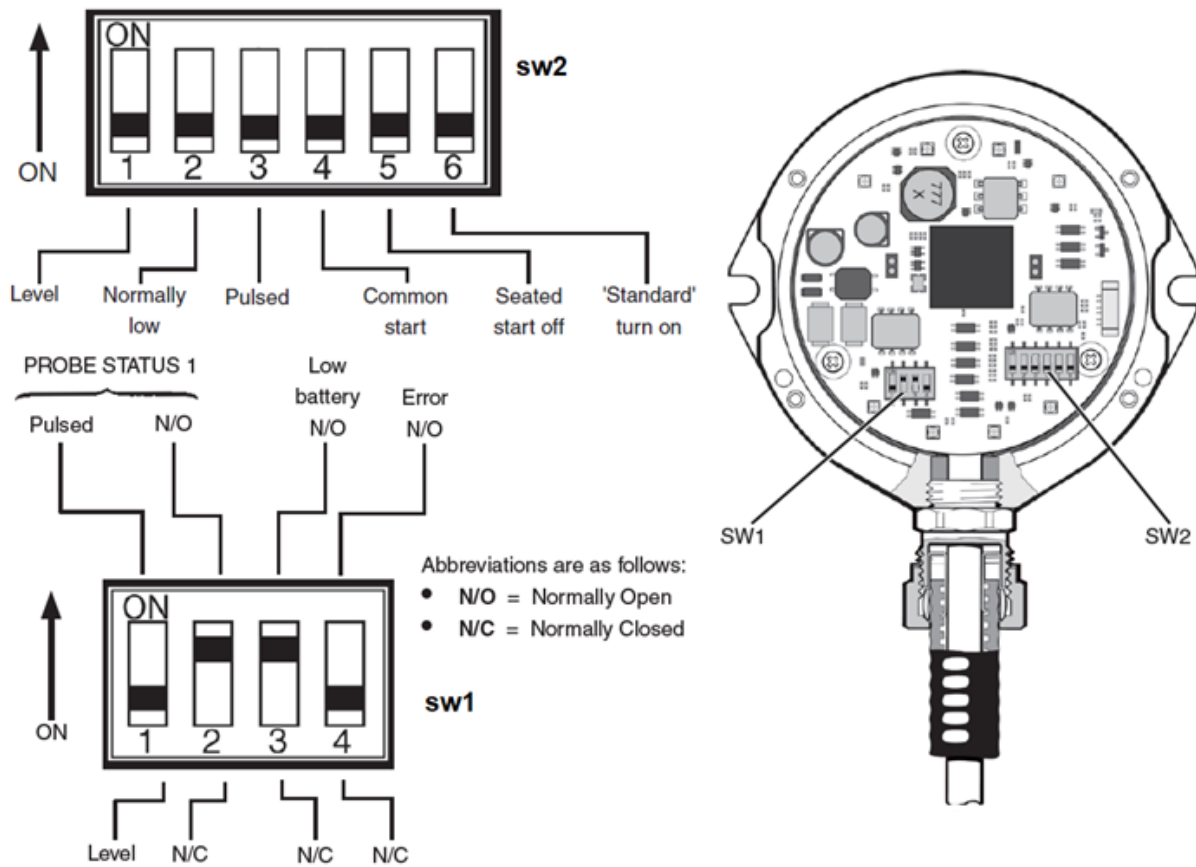

During normal use, the difference between the touch position and the reported position does not change, but it is important that the probe is calibrated in the following circumstances:

- when a probe system is to be used for the first time;
- when a new stylus is fitted to the probe;
- when it is suspected that the stylus has become distorted or that the probe has crashed;
- at regular intervals to compensate for mechanical changes of your machine tool;
- if repeatability of relocation of the probe shank is poor. In this case, the probe may need to be recalibrated each time it is selected.

It is good practice to set the tip of the stylus on center, because this reduces the effect of any variation in spindle and tool orientation. A small amount of run-out is acceptable, and can be compensated for as part of the normal calibration process.

- calibrating either in a bored hole of know size, a ring gauge, or on a datum sphere.



## Mounting the probe on a shank

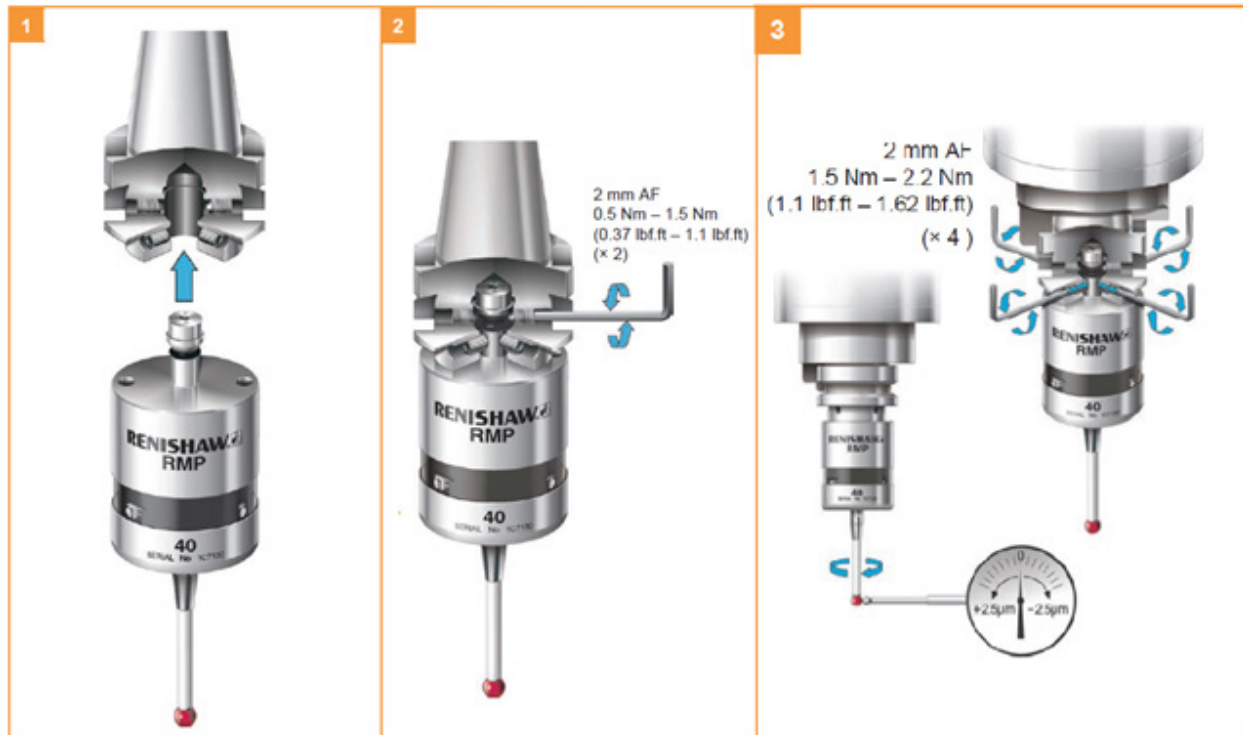

- Dial the probe stylus into center using a .0001" indicator to within .0005" the tighter tolerance you hold the more accurate the machine will be. You must use an indicator that takes very little pressure to get a reading. Excessive pressure on the stylus will deflect the probe and you will not be able to dial it in correctly.
- Go to the Main/Block Model screen and select the Table of Tools. You may only have a Default Tool #0 listed.
- Press Add Tool. This will bring up a dialog box. Change the name from default tool to probe style that you are installing i.e. 50mm stylus, 100mm stylus. Set the diameter to .2360" this is default probe tip on a 50mm, 100mm, and 17.5mm.
- Install a block, or parallels onto the machine and secure it solidly to the machine table.
- Place the Ring Gauge onto the top of the block, use Probe Auto Center to find center zero your X and Y axis here. Make sure you use a ring gauge or a hole of a known diameter. This will set the correct probe timing.
- Adjust the probed diameter by going to the IO under Setup Electronics and changing the Probe MS. You will need to increase or decrease the MS of the probe to achieve correct Probe Diameter.
- Repeat until the correct diameter is displayed.
- Probe Auto Center the ring gauge, without moving X or Y, remove the probe up in Z and Install the cutter head. Put a magnet base with the Last Word indicator on the cutter head and sweep the cylinder/ring gauge.
- The variation in X and Y Should be less than .0005.
- If not add compensation to ProbeOffset under > Setup Eletronics-Addins-ProbeSetup

## Replacing the Motherboard Battery

If computer fails to boot up and you get a CMOS error message on the screen, then the battery on the computer motherboard has failed and needs to be replaced.

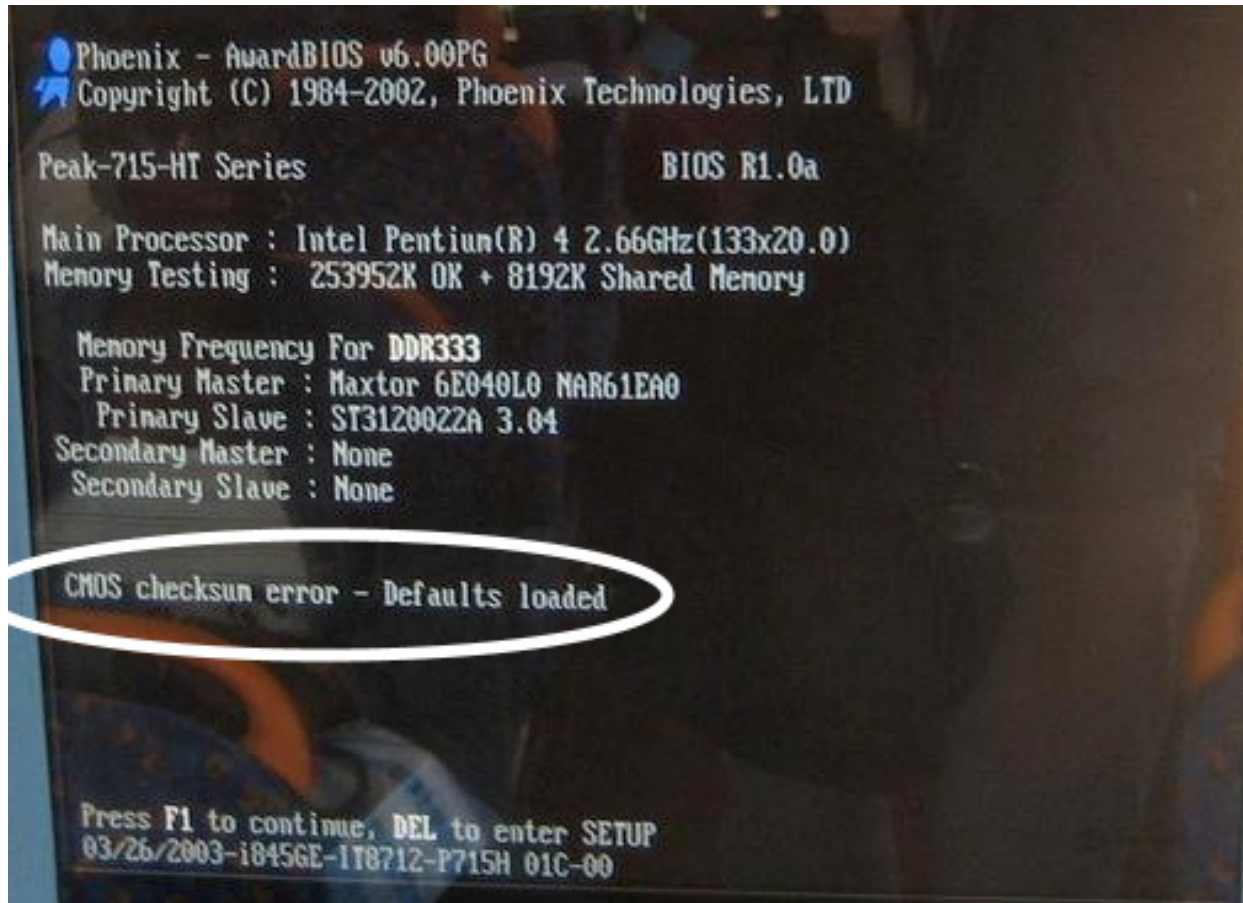

The following is the procedure for replacing the motherboard battery.

Turn off the power on the electrical enclosure and remove the enclosure cover.



Locate the computer and check to see that the power light is not on. If it is on turn off the power switch.  
*Note: On some machines it may be necessary to unbolt the computer from the enclosure in order to gain access to the cover screws.*

Remove the 6 screws indicated by the arrows from the cover.

Remove the cover.





Locate the battery on the motherboard.



Push the battery retention clip away from the battery. When the clip is released the battery will pop up.

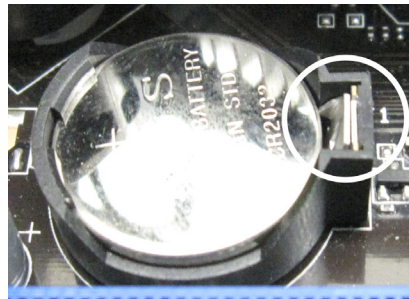

Remove the battery and place new battery in the battery holder.

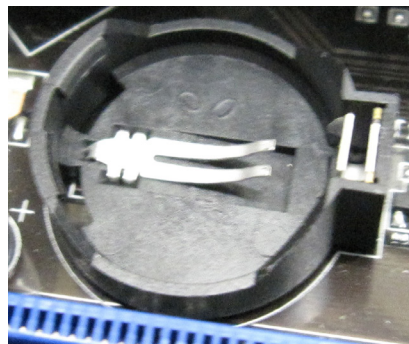

Using your finger tip push down on the battery until the retention clip is in its lock position.



Replace computer cover and make sure that power switch on the computer is on.  
Replace the enclosure cover and switch power back on.

## Ballscrew Assemblies Reference

### Alignment Definitions for Angular Bearings and Belleville Washers

#### Bearing Alignment



VIEW OPEN END UP

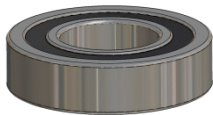

VIEW CLOSED END UP

#### Belleville Washer Alignment



VIEW CUP UP



VIEW CUP DOWN

### Z-Axis Lower Bearing and Belleville Washer Stacking Order

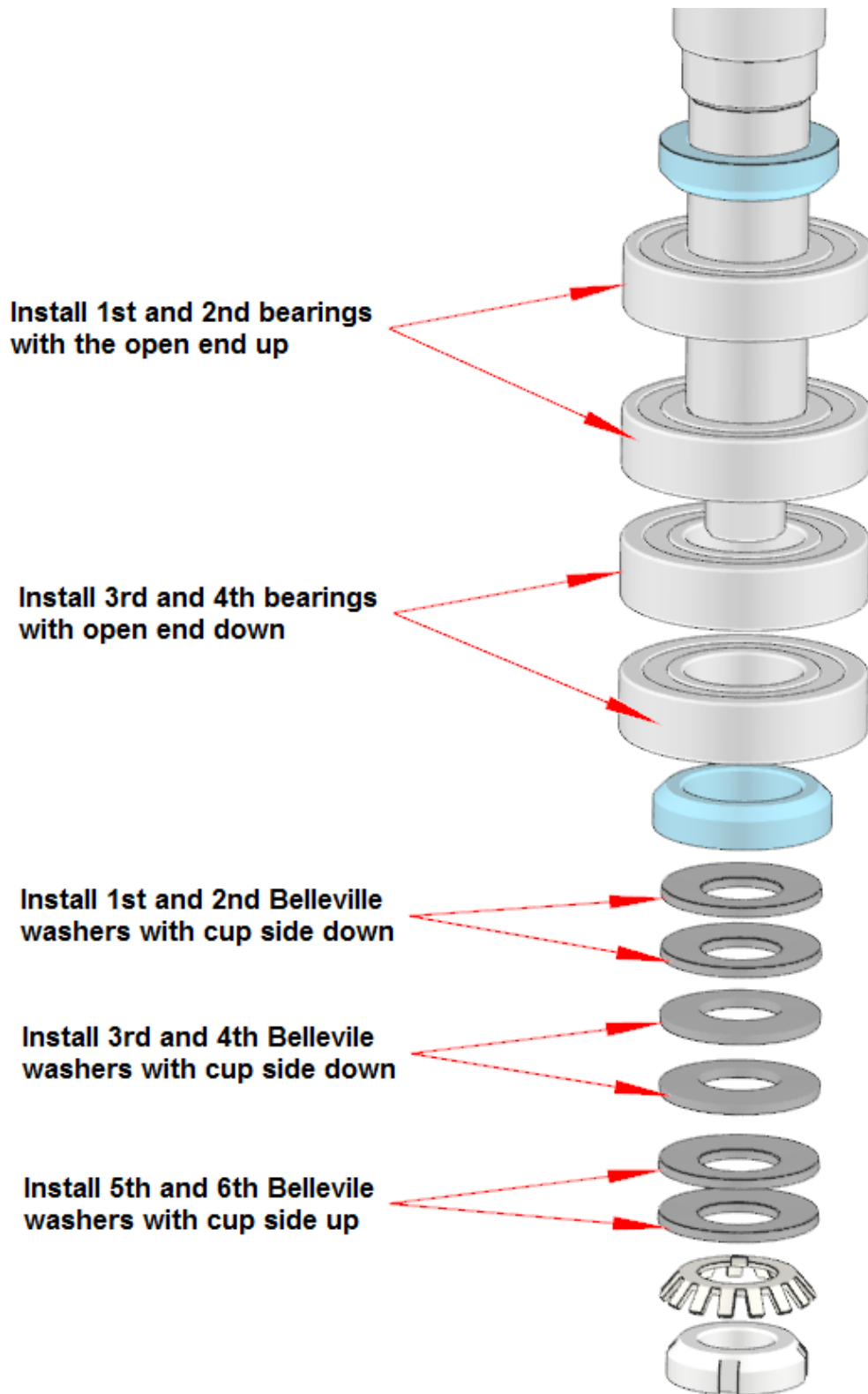

**Z-Axis Lower Bearing and Belleville Washer Section View**

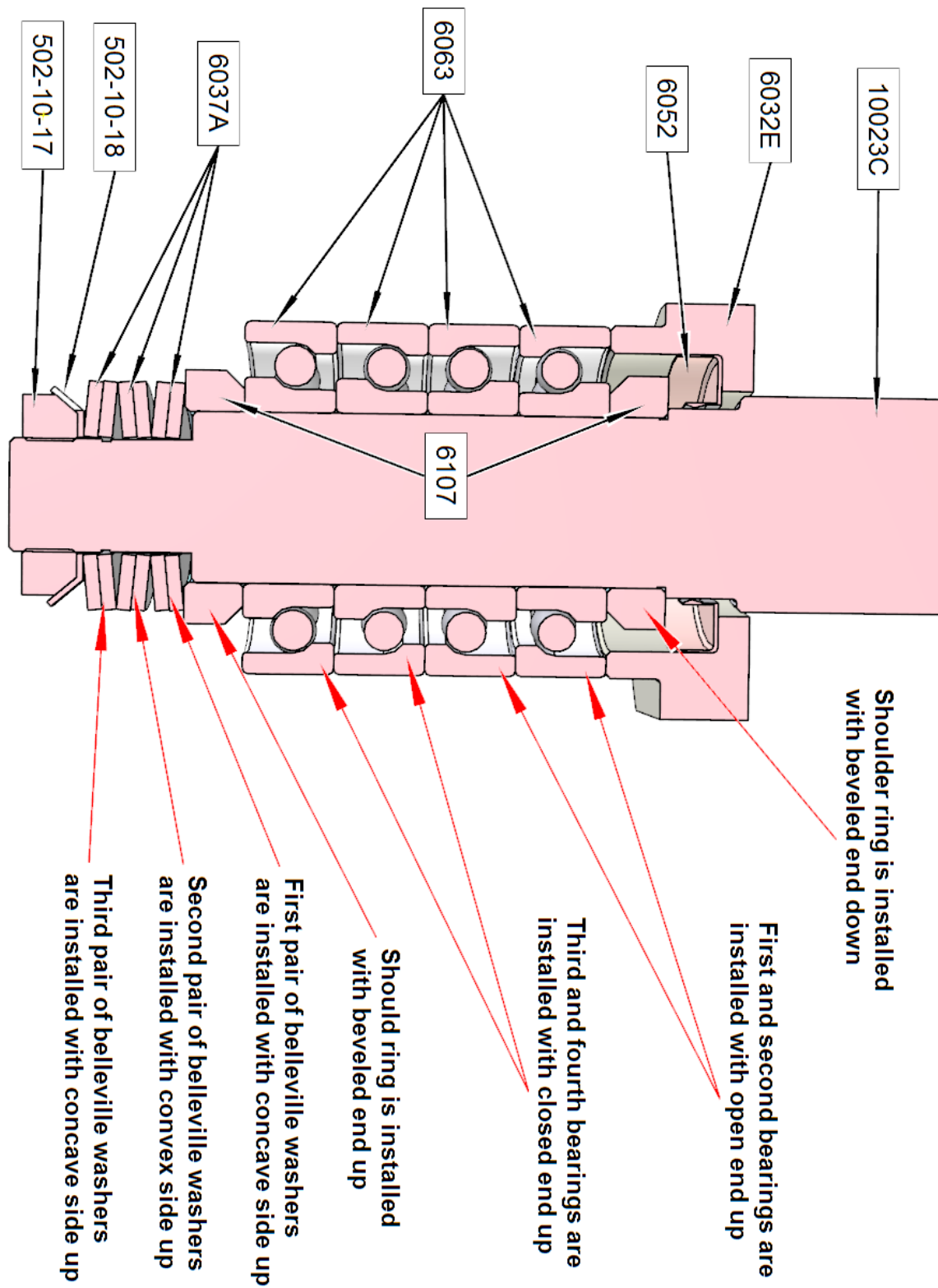



### Z-Axis Upper Belleville Washer Stacking Order

Install 1st washer with cup side facing out, then alternate next 3 washers.

### Z-Axis Upper Belleville Washer Section View

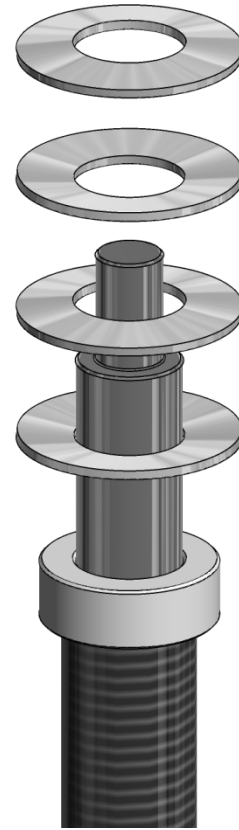
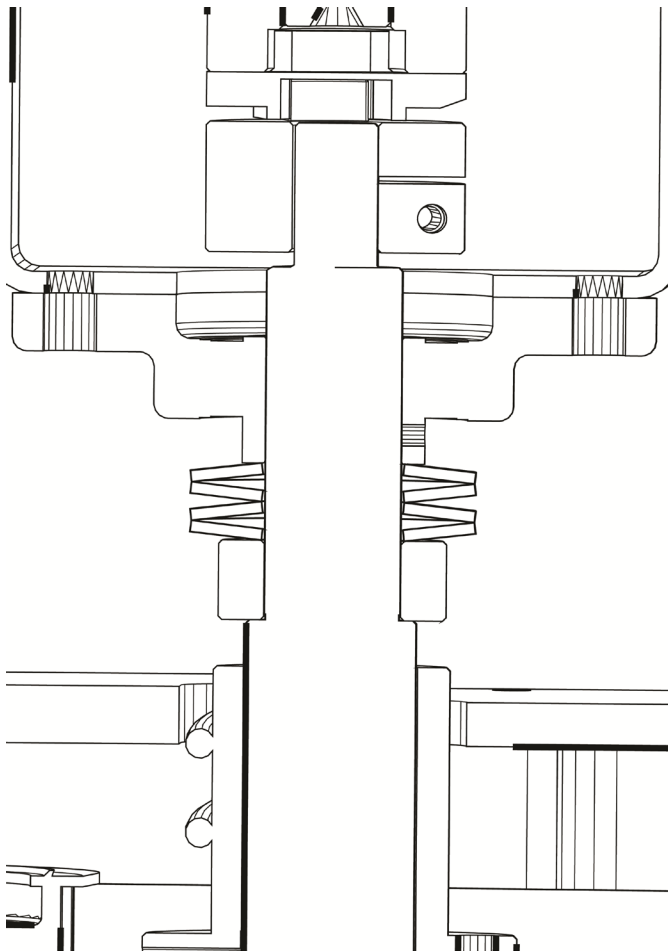

### Y-Axis Bearing Stacking Order

Install 1st bearing with open end toward ballscrew shoulder. Install 2nd and 3rd bearings with closed end toward 1st bearing.

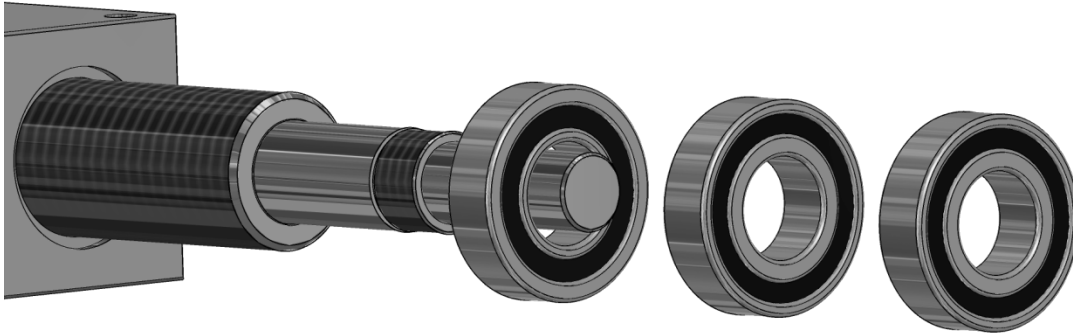

### Y-Axis Bearing Assembly Section View

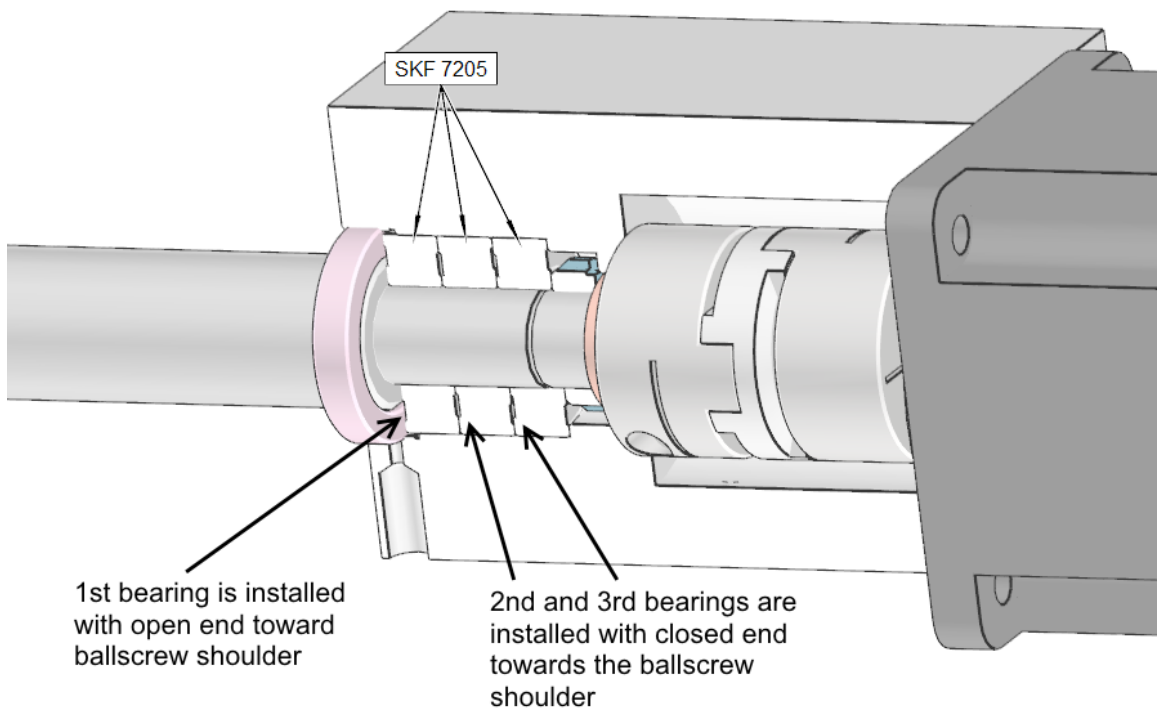

### Inner Spindle Upper Segment Belleville Washer Stacking Order

6113 Belleville washers are stacked in an alternating pattern with the bottom washer installed cup face up. (see illustration on right side)

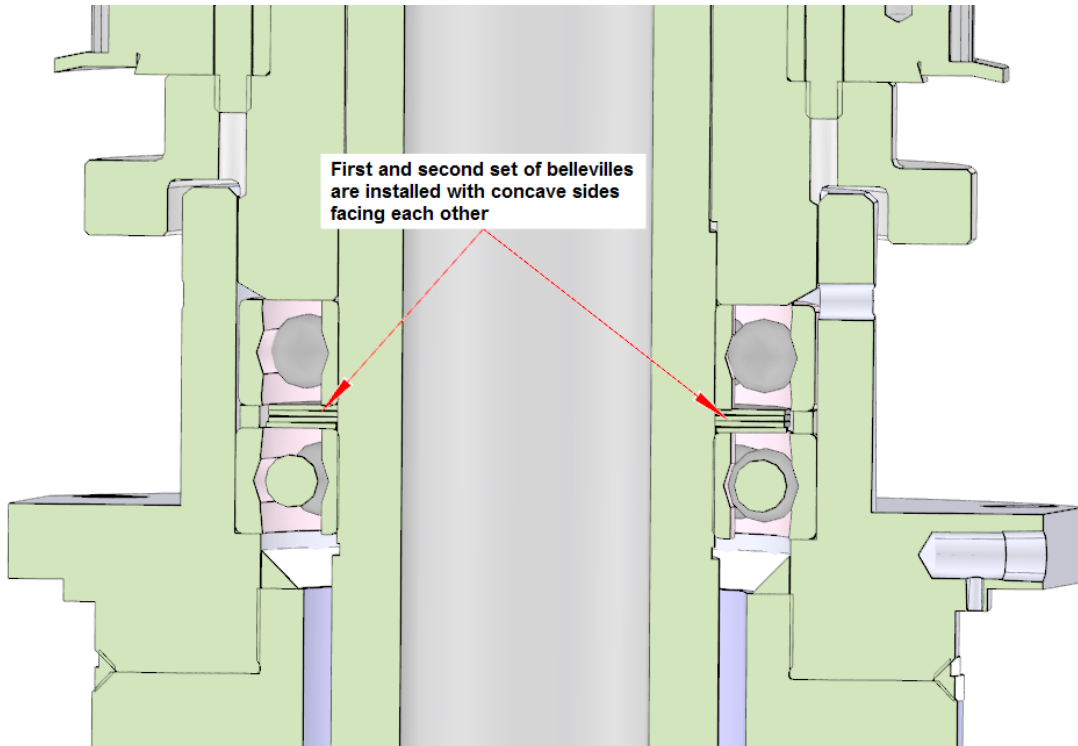
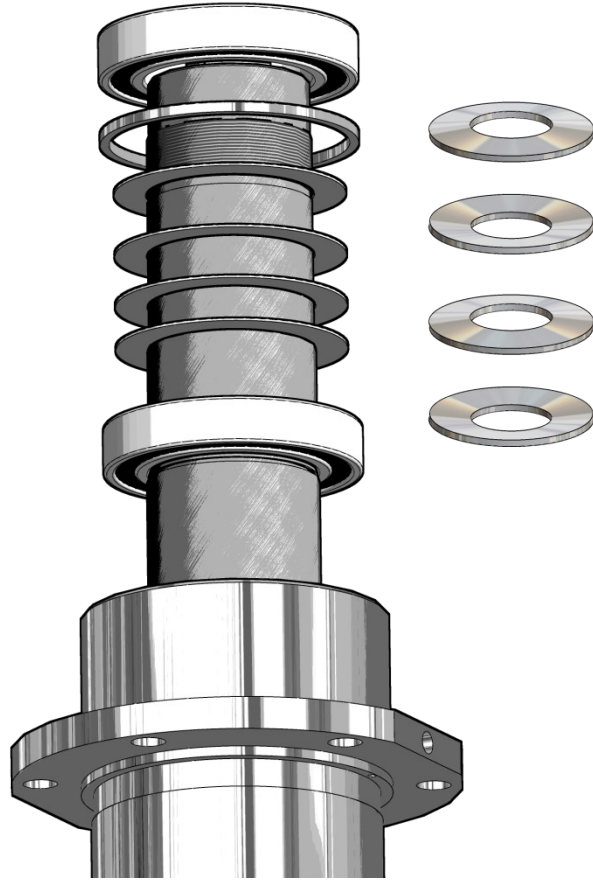

### Inner Spindle Lower Section Bearing Stacking Order

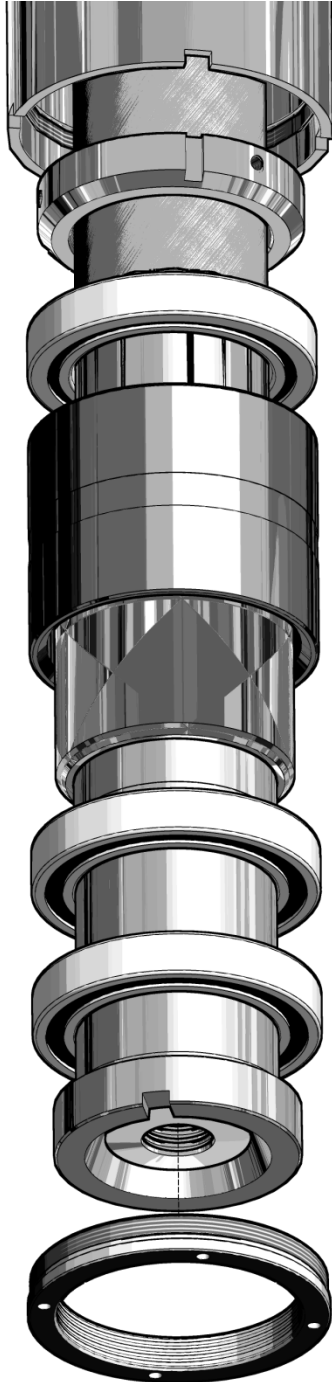

Install 3rd bearing with the closed side down.

Install inner and outer spacer assembly with beveled end facing up.

Install 2nd bearing with the open side down.

Install 1st bearing with the open side down.

**Inner Spindle Lower Segment Section View**

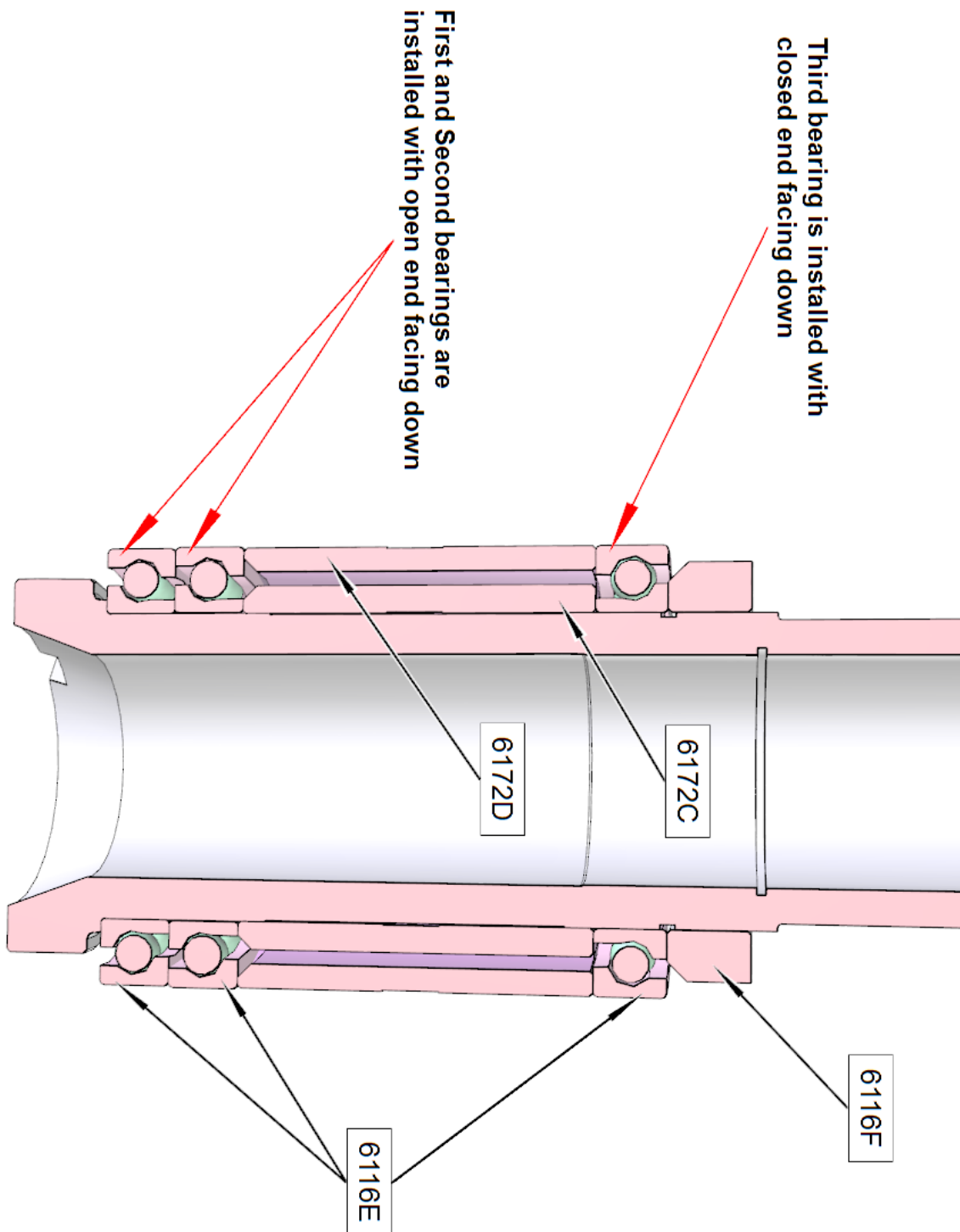

### X-Axis Idle End Bearing Stack Order

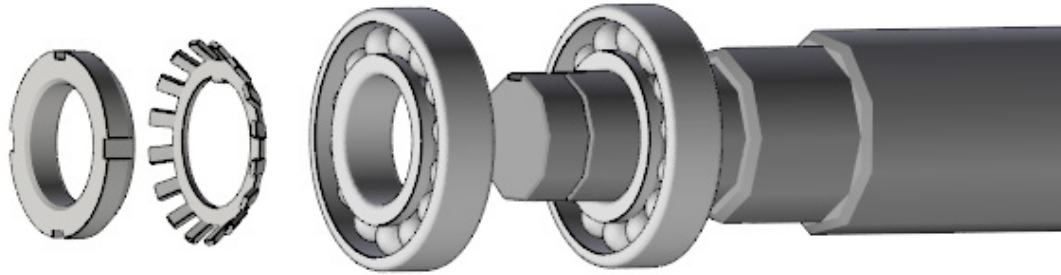

Both bearings are installed with the open end facing out.

### X-Axis Idle End Section View

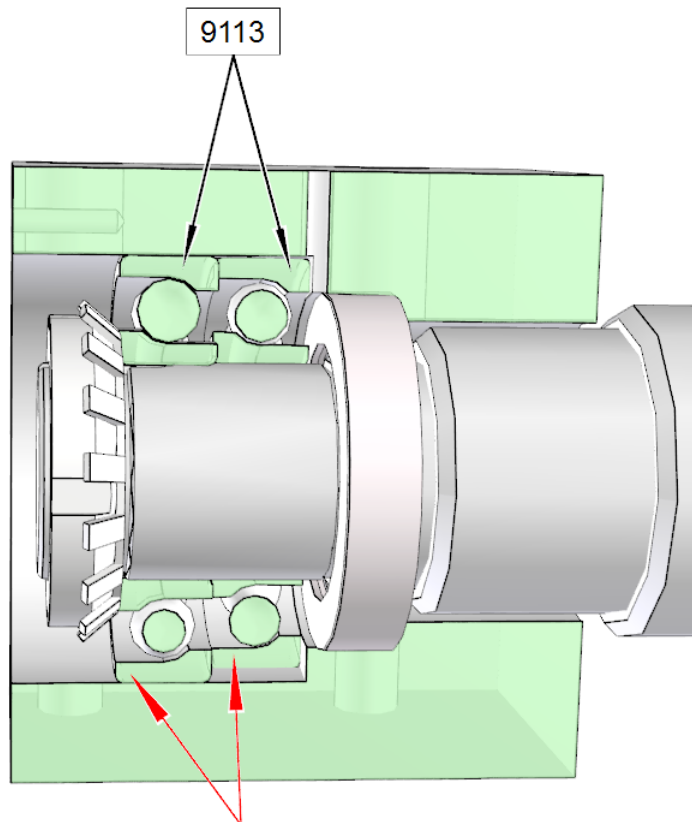

**Both bearings are installed  
with open end facing out**

### X-Axis Drive End Bearing Stack Order

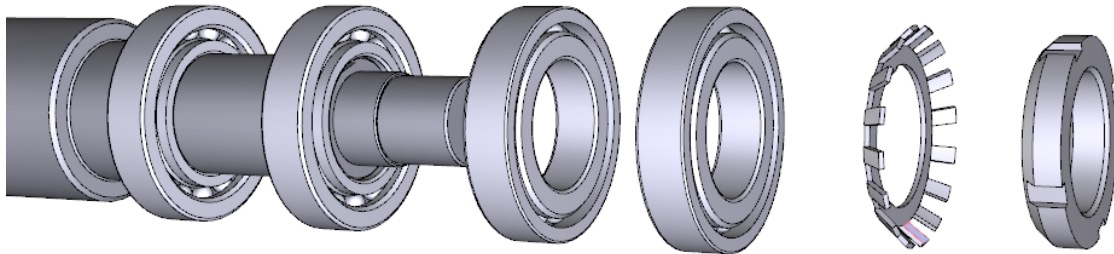

### X-Axis Drive End Section View

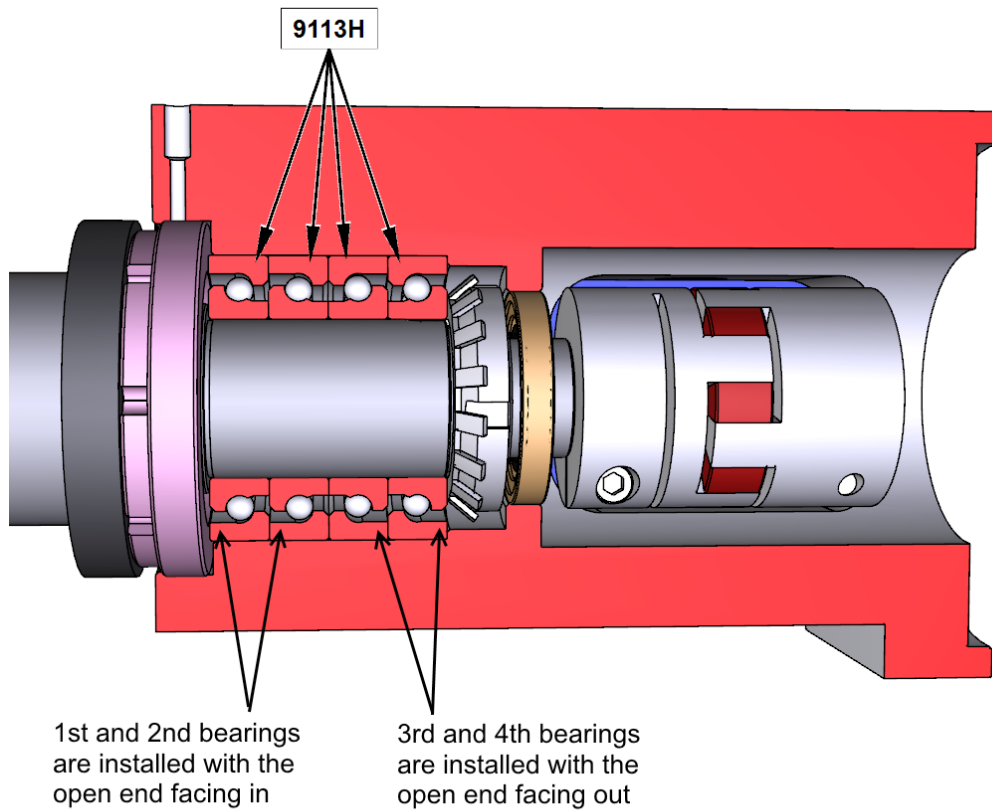



# TROUBLESHOOTING

**Problem:**

Icon on screen does not move to area touched.

**Solution:**

Follow the procedure below to recalibrate the touchscreen.

1. Get to the Alignment screen.
  1. If an Elo icon is available in the tool tray at the lower right side of the desktop, click it, then click Align.
  2. Otherwise, go to the Windows Control Panel, double-click Elo Touchscreen and click the Align button on the General tab.
    1. If Windows XP and no Elo icon, click the "Switch to Classic View" button on the left
    2. If Windows 7 and no Elo icon, look for "View by: Category" text toward the upper right; click it and select "Small icons"
2. Touch and release the upper left target; the target should jump to the lower right.
3. Touch and release the lower right target; the target should jump to the upper right.
4. Touch and release the upper right target; a check screen should appear.
5. Touch and release the green check mark; the check screen should disappear.
6. The cursor should now jump to the point of touch.
7. If the Elo Control Panel is open, close it and the Windows Control Panel.

## Chatter Problems

If you are having chatter problems when you are boring you should do the following steps;

1. Replace the insert, Make sure you use Rottler RT321 inserts it is strongly advised.
2. Clean the inside of the bore head. Oil will build up if you leave the boring head in the machine overnight or have the oiler turned up. You will need to clean any oil off of the counterweight (11), also clean the cavity that the counterweight sits in. This is done by removing the bolts (15). This procedure is the same with other Rottler cutter heads. See the optional equipment parts catalogue for breakdowns of the cutter heads.
3. Check Inner Spindle Adjustment, see maintenance section.
4. Check outer spindle adjustment/bushings, see maintenance section.
5. Newer models we recommend the use of the SSV system, if you are having chatter issues.
6. Counter balance cable pressure; verify that it is in service and unbroken. See maintenance section.

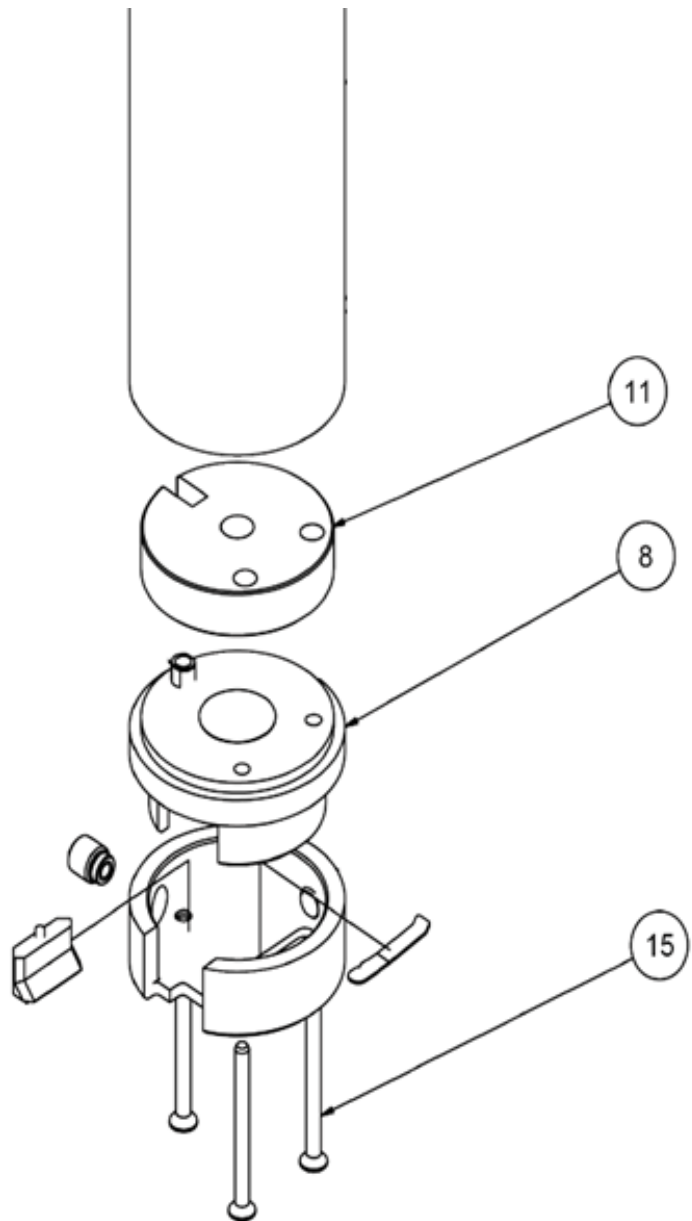

# MACHINE PARTS

## Contents

<b>Machine Parts</b> .....	<b>8-1</b>
<b>Base Anchor Components</b> .....	<b>8-1</b>
<b>Linear Rail Attachment</b> .....	<b>8-2</b>
<b>Incoming Service Box</b> .....	<b>8-3</b>
<b>Base Wire Track Channel</b> .....	<b>8-4</b>
<b>X-Axis Drive Components</b> .....	<b>8-4</b>
<b>Ballscrew Nut</b> .....	<b>8-4</b>
<b>Idle End Components</b> .....	<b>8-5</b>
<b>Motor Housing Components</b> .....	<b>8-6</b>
<b>Motor Components</b> .....	<b>8-7</b>
<b>X-Axis Mounting</b> .....	<b>8-8</b>
<b>Base Wire Track</b> .....	<b>8-10</b>
<b>Column Components</b> .....	<b>8-12</b>
<b>Bottom Linear Way Components</b> .....	<b>8-12</b>
<b>Tilt Wedge Assembly</b> .....	<b>8-13</b>
<b>Lift Cylinders</b> .....	<b>8-14</b>
<b>Shield and Wiper</b> .....	<b>8-15</b>
<b>Oiler Door Components</b> .....	<b>8-16</b>
<b>Solenoid Pack</b> .....	<b>8-17</b>
<b>Regulator/Filter Assembly</b> .....	<b>8-18</b>
<b>Outside Air Door Components</b> .....	<b>8-19</b>
<b>Inside Air Door Components</b> .....	<b>8-20</b>
<b>Y-Axis Drive Components</b> .....	<b>8-21</b>
<b>Idle End</b> .....	<b>8-21</b>
<b>Motor Housing Components</b> .....	<b>8-22</b>
<b>Motor Components</b> .....	<b>8-23</b>
<b>Y-Axis Mounting</b> .....	<b>8-24</b>
<b>Spindle Base Tower and Cable Cylinder</b> .....	<b>8-25</b>

<b>Inner Spindle Components</b> .....	<b>8-26</b>
Lower Section Components .....	8-26
Upper Section Components.....	8-27
<b>Drawbar Components</b> .....	<b>8-30</b>
Upper Section.....	8-30
<b>Spindle Base Components</b> .....	<b>8-31</b>
Upper Spindle Bushing Carrier .....	8-31
Lower Spindle Bushing Carrier .....	8-32
<b>Upper Spindle Bushing Components</b> .....	<b>8-33</b>
<b>Lower Spindle Bushing Components</b> .....	<b>8-34</b>
<b>Z-Axis Assembly</b> .....	<b>8-35</b>
Ballscrew Nut to Motor Housing Components .....	8-35
Lower Section Components .....	8-36
Upper Section Components.....	8-37
<b>Z-Axis Assembly Installation onto Spindle</b> .....	<b>8-38</b>
<b>Motor Housing Components</b> .....	<b>8-39</b>
Internal Components .....	8-39
<b>Motor and Adjusting Components</b> .....	<b>8-40</b>
<b>Guide Block Assembly</b> .....	<b>8-41</b>
<b>Drawbar Clamp</b> .....	<b>8-43</b>
<b>Cable Cylinder Components</b> .....	<b>8-44</b>
Lower Section .....	8-44
<b>Top Plate Components</b> .....	<b>8-45</b>
<b>Z-Axis Motor Connection</b> .....	<b>8-46</b>
<b>Upper Section</b> .....	<b>8-47</b>
<b>Counterbalance Cylinder Pop Off Valve Assembly Parts</b> .....	<b>8-48</b>
<b>Top Plate Pulley Assembly</b> .....	<b>8-49</b>
<b>Spindle Base Front Covers</b> .....	<b>8-50</b>
Brackets.....	8-50
<b>Covers and Lights</b> .....	<b>8-51</b>
<b>Column Lower Section Components</b> .....	<b>8-53</b>
<b>Spindle Base Gib Assemblies</b> .....	<b>8-54</b>

<b>Right Side</b> .....	<b>8-54</b>
<b>Left Side</b> .....	<b>8-55</b>
<b>Spindle Base Wire Box</b> .....	<b>8-56</b>
<b>Spindle Motor Wire Track</b> .....	<b>8-57</b>
<b>Pendent and Control Housing</b> .....	<b>8-58</b>
<b>Control Housing Outside Components</b> .....	<b>8-60</b>
<b>Control Housing Inside Components</b> .....	<b>8-61</b>
<b>Machine Base</b> .....	<b>8-62</b>
<b>Spindle Base Covers</b> .....	<b>8-63</b>
<b>Chip Shield</b> .....	<b>8-66</b>
<b>Outside Parts</b> .....	<b>8-66</b>
<b>Inside Parts</b> .....	<b>8-67</b>
<b>Oil Line Diagrams</b> .....	<b>8-68</b>
<b>Air Line Diagram</b> .....	<b>8-69</b>
<b>Electrical Wiring Diagram</b> .....	<b>8-70</b>
<b>Electrical Enclosure</b> .....	<b>8-71</b>
<b>Outside Parts</b> .....	<b>8-71</b>
<b>Enclosure Door</b> .....	<b>8-74</b>
<b>Inside Parts</b> .....	<b>8-75</b>
<b>Electrical Panel Parts</b> .....	<b>8-78</b>
<b>Computer Components</b> .....	<b>8-81</b>
<b>Way Covers</b> .....	<b>8-83</b>
<b>Way Cover Supports</b> .....	<b>8-84</b>

## Machine Parts

### Base Anchor Components

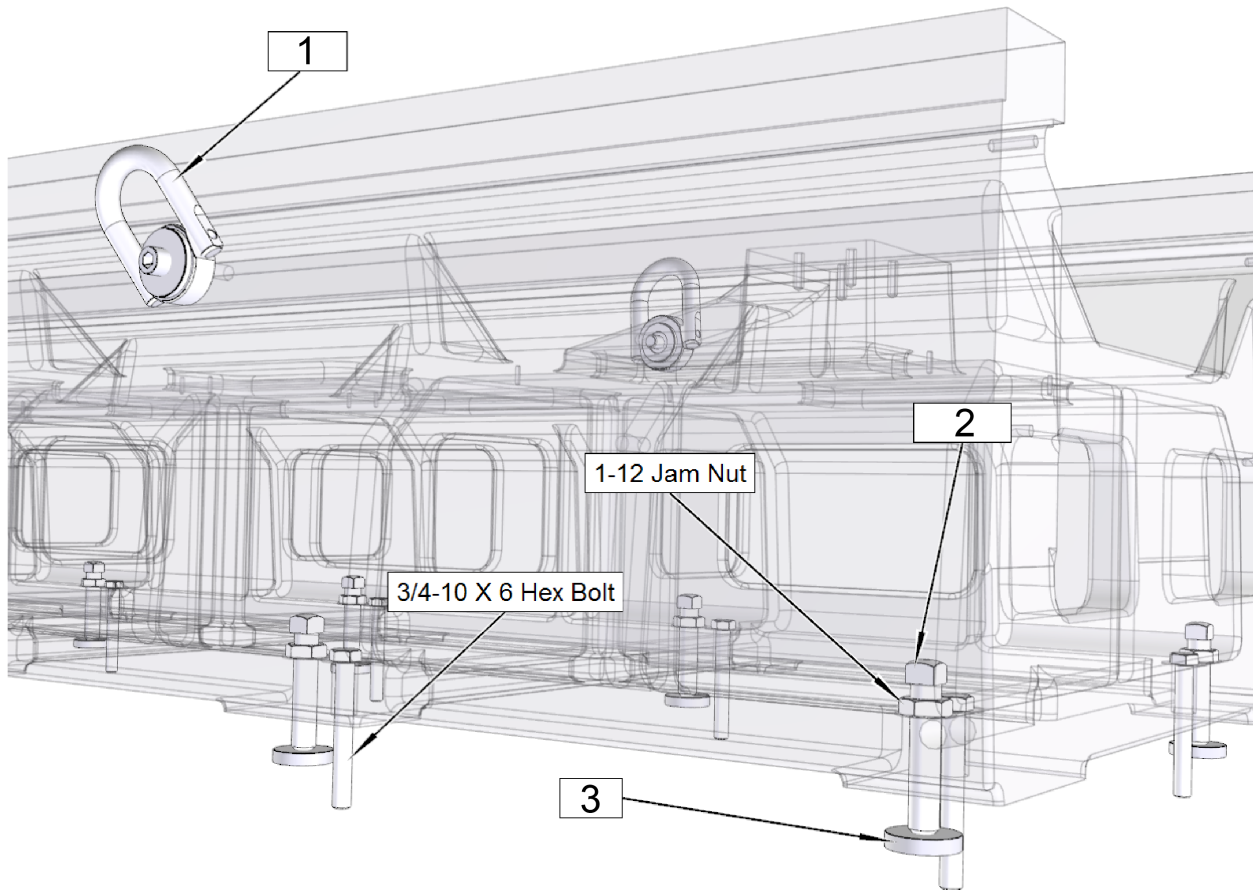

ITEM	PART #	DESCRIPTION
1	9227C	RING, HOIST OR LIFTING EYE
2	6150E	JACKING SCREW--1-12 UNF X 5" LONG-FLAT TIP
3	6080F	PAD, JACKING

## Linear Rail Attachment

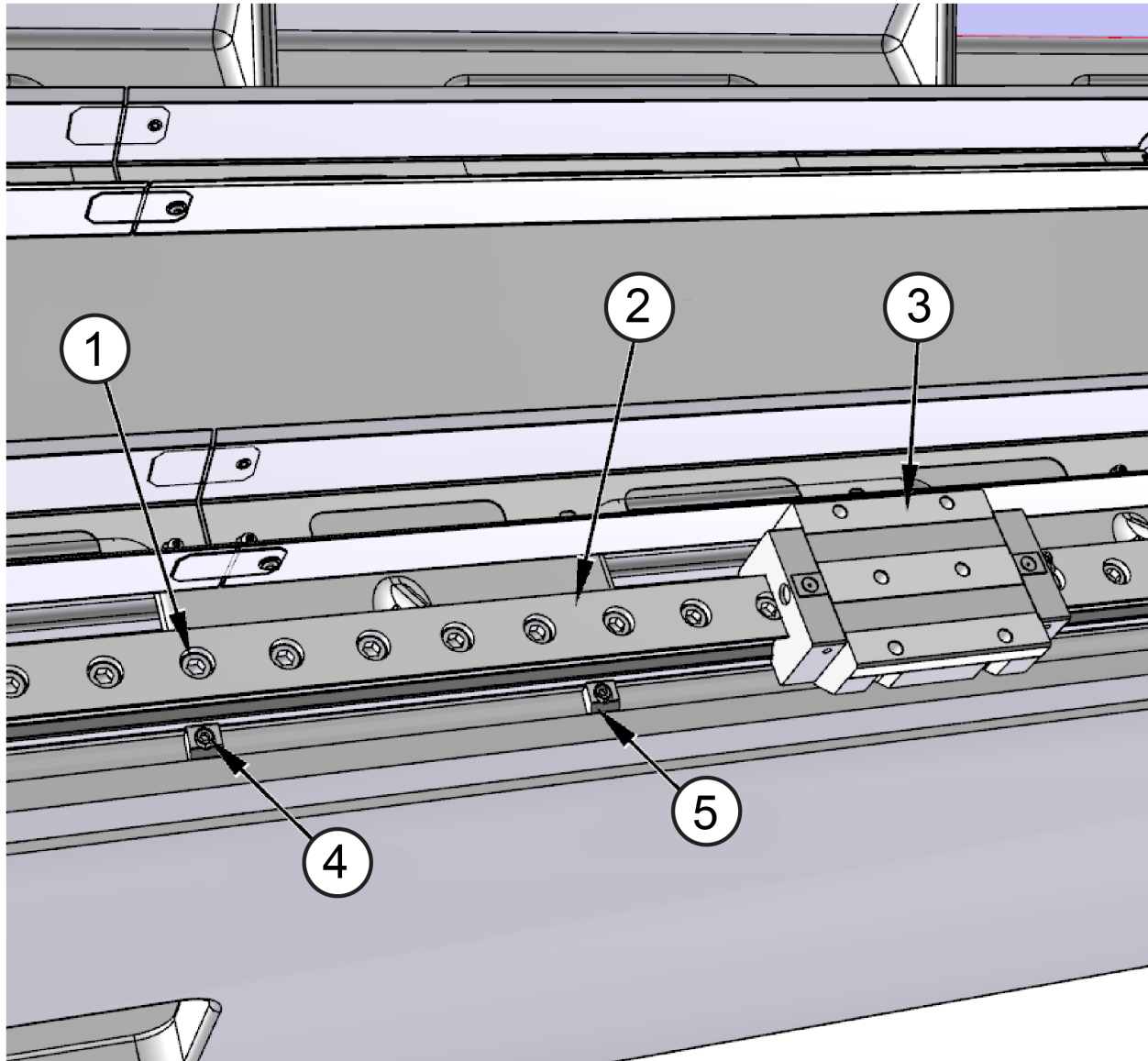

ITEM	PART #	DESCRIPTION
1	MF-44	SOCKET HEAD CAP SCREW 1/2-13 X 1 1/2"
2	10045	LINEAR RAIL
3		RAIL CAR
4	MF-5A	SOCKET HEAD CAP SCREW 10-24 X 1/2"
5	10043A	CLAMP, LINEAR RAIL



### Incoming Service Box

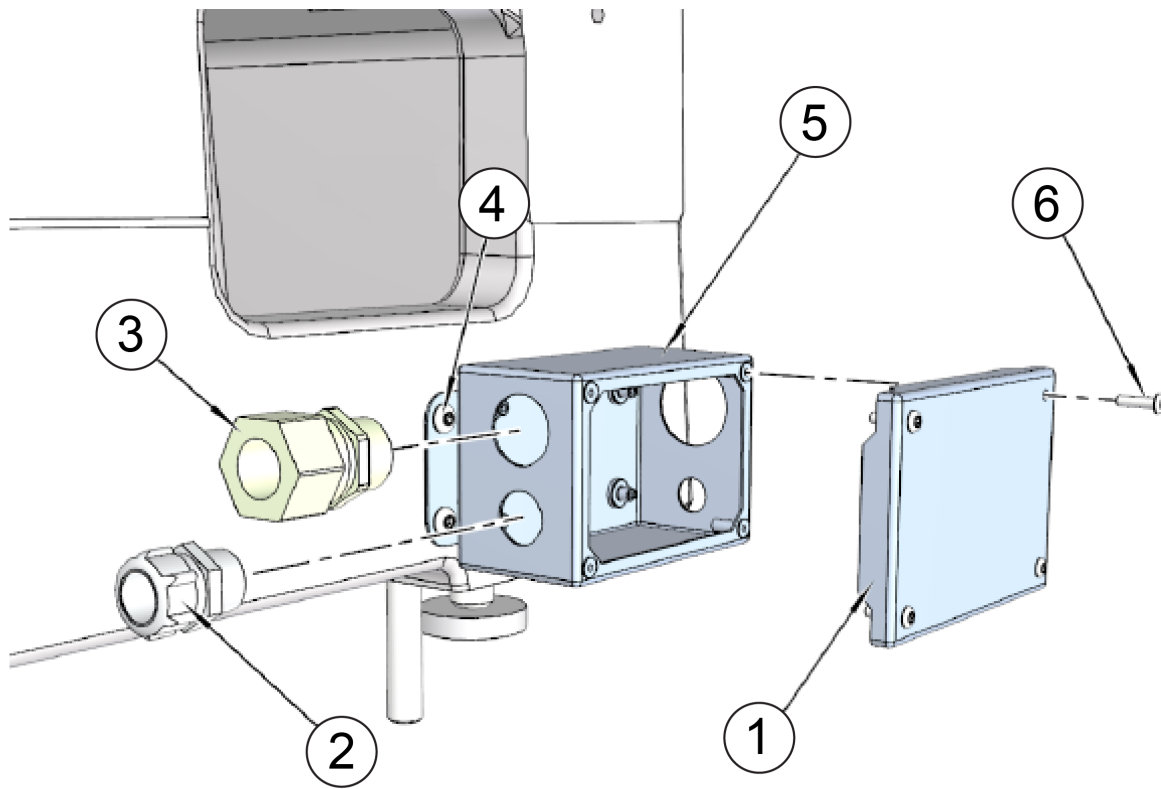

ITEM	PART #	DESCRIPTION
1	6351N	BOX, ELECTRICAL SUPPLY HOOKUP
2	6354E	STRAIN RELIEF-3/4" (5/8 TO 3/4")
3	6334	STRAIN RELIEF -1"
4	MF-93A	SOCKET BUTTON HEAD SCREW 5/16-18 X 1/2"
5	6351Q	BOX,ELECTRICAL SUPPLY HOOKUP
6	MF-89A	SOCKET BUTTON HEAD SCREW 10-32 X 5/8"

**Base Wire Track Channel**

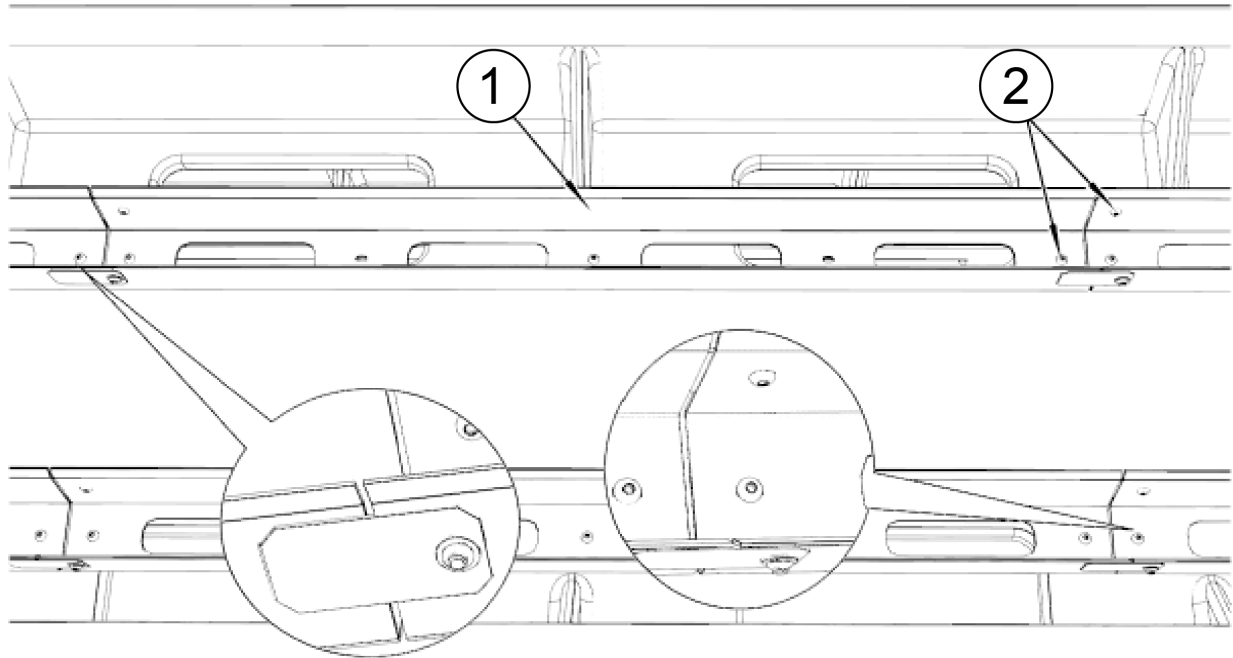

ITEM	PART #	DESCRIPTION
1	9219D	TRACK, CABLE CARRIER
2	MF-248	SOCKET BUTTON HEAD SCREW 1/4-20 X 3/8"

**X-Axis Drive Components**

**Ballscrew Nut**

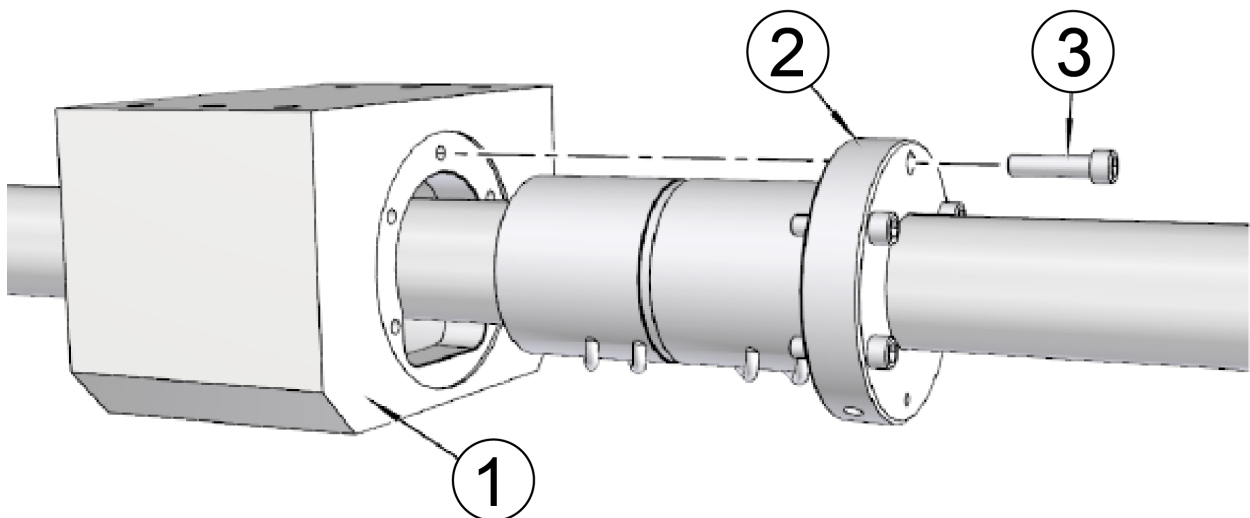

ITEM	PART #	DESCRIPTION
1	10008P	MOUNT, COLUMN X-AXIS BALLSCREW
2	10007	HORIZONTAL BALLSCREW COLUMN FEED ASSEMBLY
3	MF-33	SOCKET HEAD CAP SCREW 3/8-16 X 1 1/2"

**Idle End Components**

See Maintenance Section for bearing installation procedure.

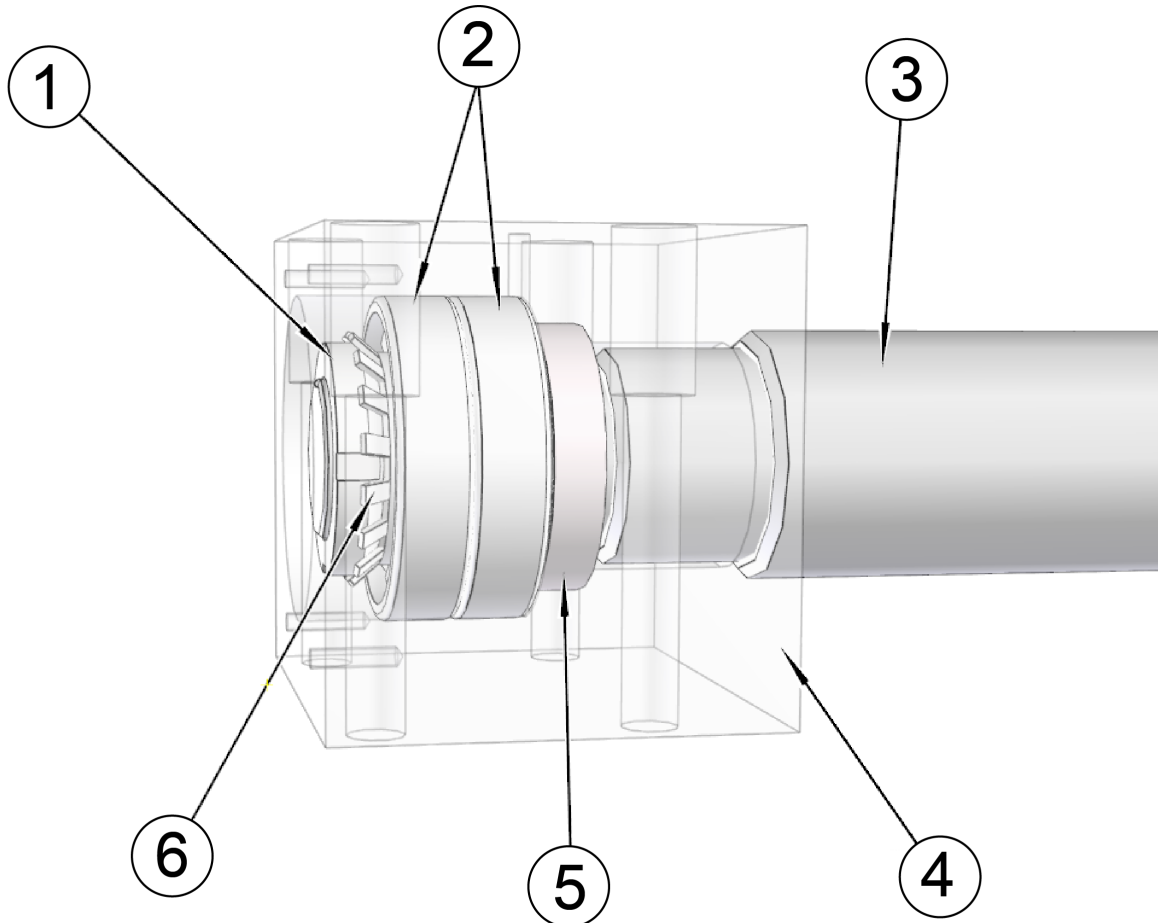

ITEM	PART #	DESCRIPTION
1	9113A	LOCK NUT
2	9113	BEARING, ANGULAR CONTACT
3	10007S 10007T	HORIZONTAL BALLSCREW ASSEMBLY-F109 HORIZONTAL BALLSCREW ASSEMBLY-F107
4	9112F	BALLSCREW SUPPORT-X-AXIS
5	9113G	SEAL
6	9113B	LOCK WASHER

### Motor Housing Components

See Maintenance Section for bearing installation procedure.

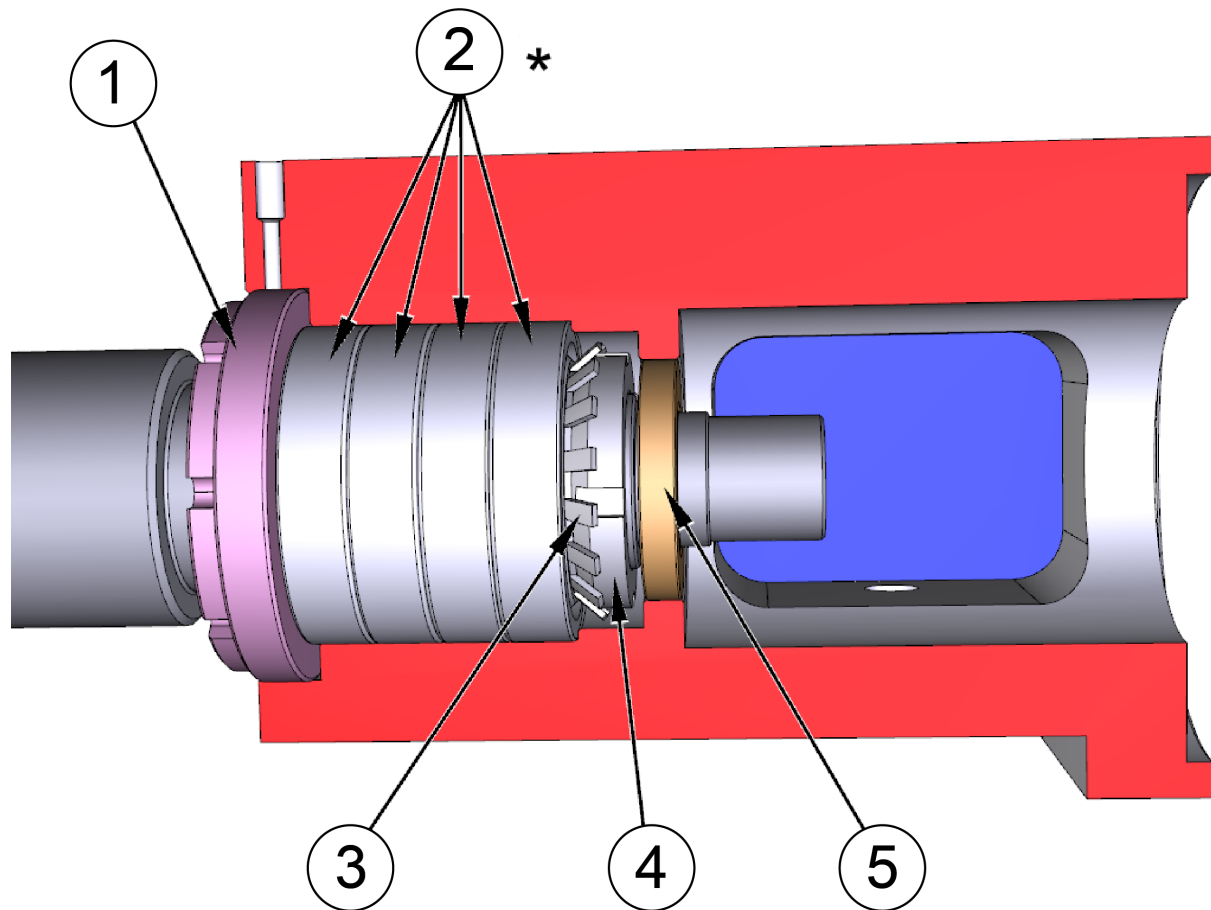

\* See maintenance section  
of this manual for correct  
bearing installation procedure

ITEM	PART #	DESCRIPTION
1	9113J	NUT, BEARING RETAINING
2	9113H	BEARING, X-AXIS BALLSCREW
3	9113B	LOCK WASHER
4	9113A	LOCK NUT
5	9113F	SEAL

## Motor Components

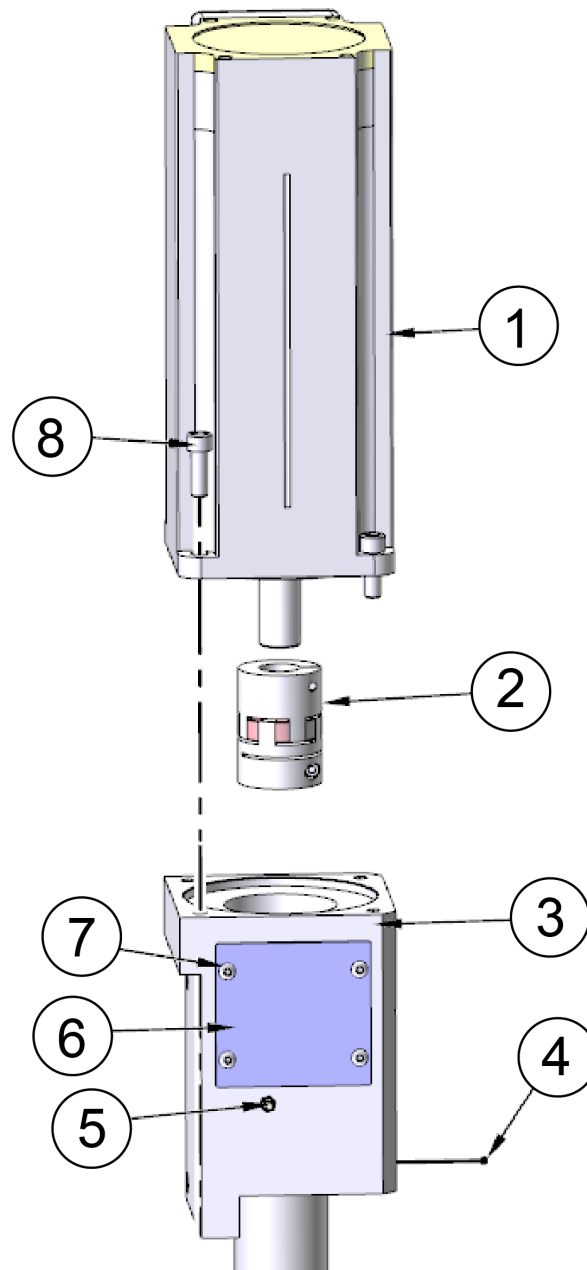

ITEM	PART #	DESCRIPTION
1	10007U	MOTOR WITH BISS ENCODER-HORIZONTAL(X-AXIS)-DIRECT DRIVE
2	9113M	COUPLING ASSEMBLY
3	9212C	HOUSING, BALLSCREW DRIVE - X-AXIS
4	100-82-2	SCREW,SET-BRASS GIB - 3/16" LONG
5	MF-191A	5/16-32 STRAIGHT LUBE GREASE FITTING
6	9113D	COVER, SUPPORT HOUSING
7	MF-248	SOCKET BUTTON HEAD SCREW 1/4-20 X 3/8"
8	MF-39A	SOCKET HEAD CAP SCREW 7/16-14 X 1 1/2"

**X-Axis Mounting**

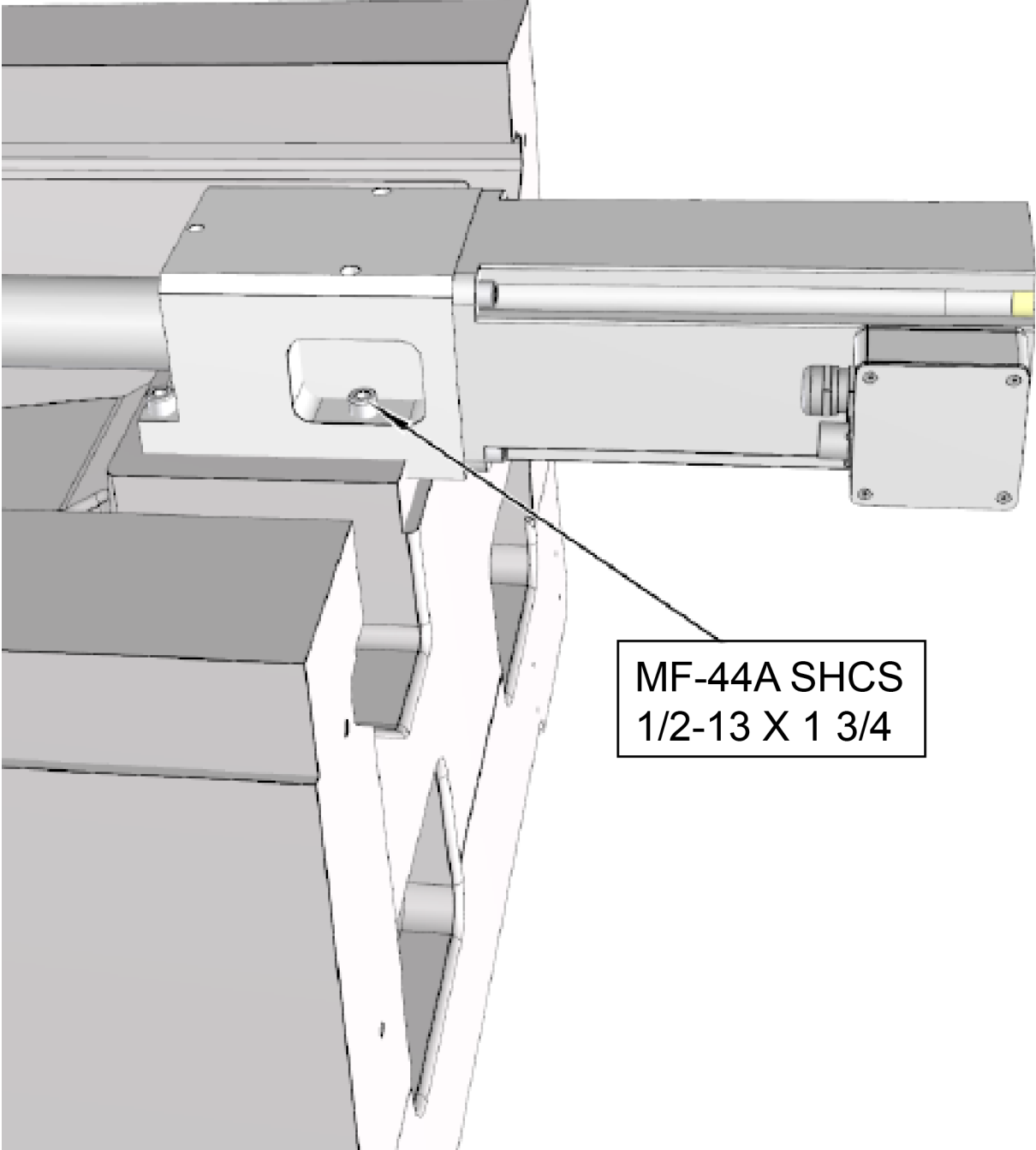

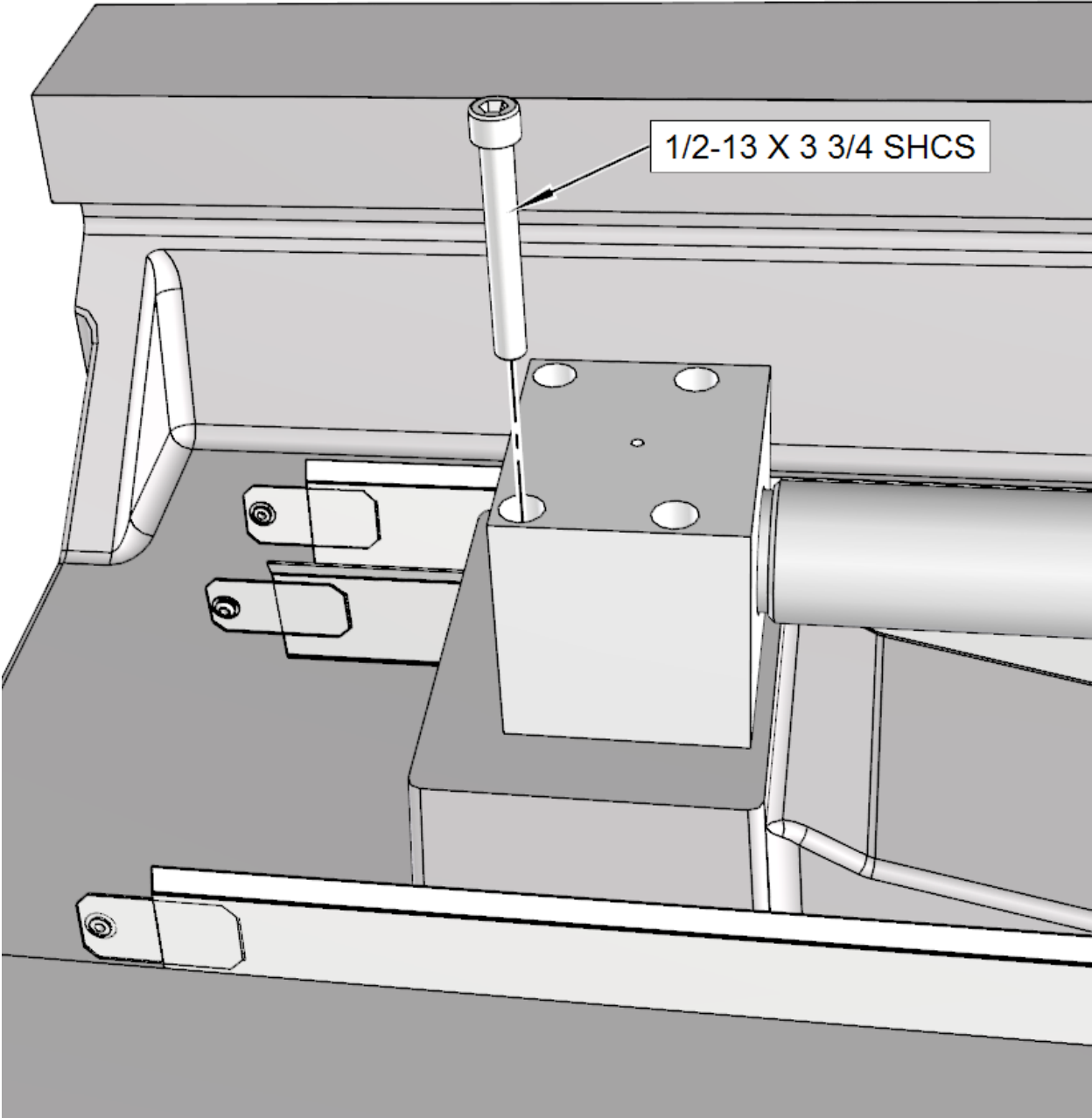



**Base Wire Track**

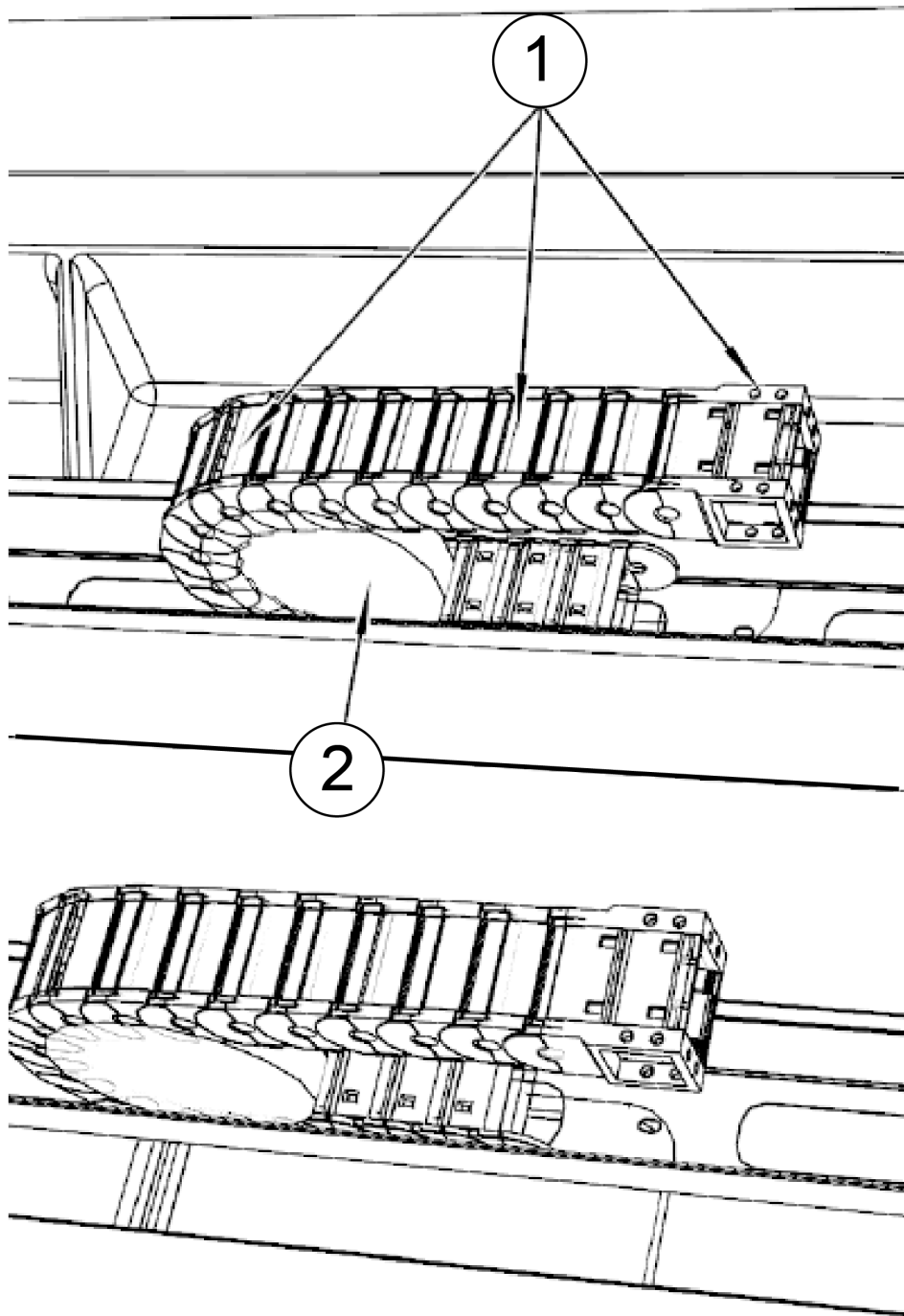

ITEM	PART #	DESCRIPTION
1	10027G	HORIZONTAL CABLE CARRIER
2	11011	CABLE CARRIER, MACHINE BED

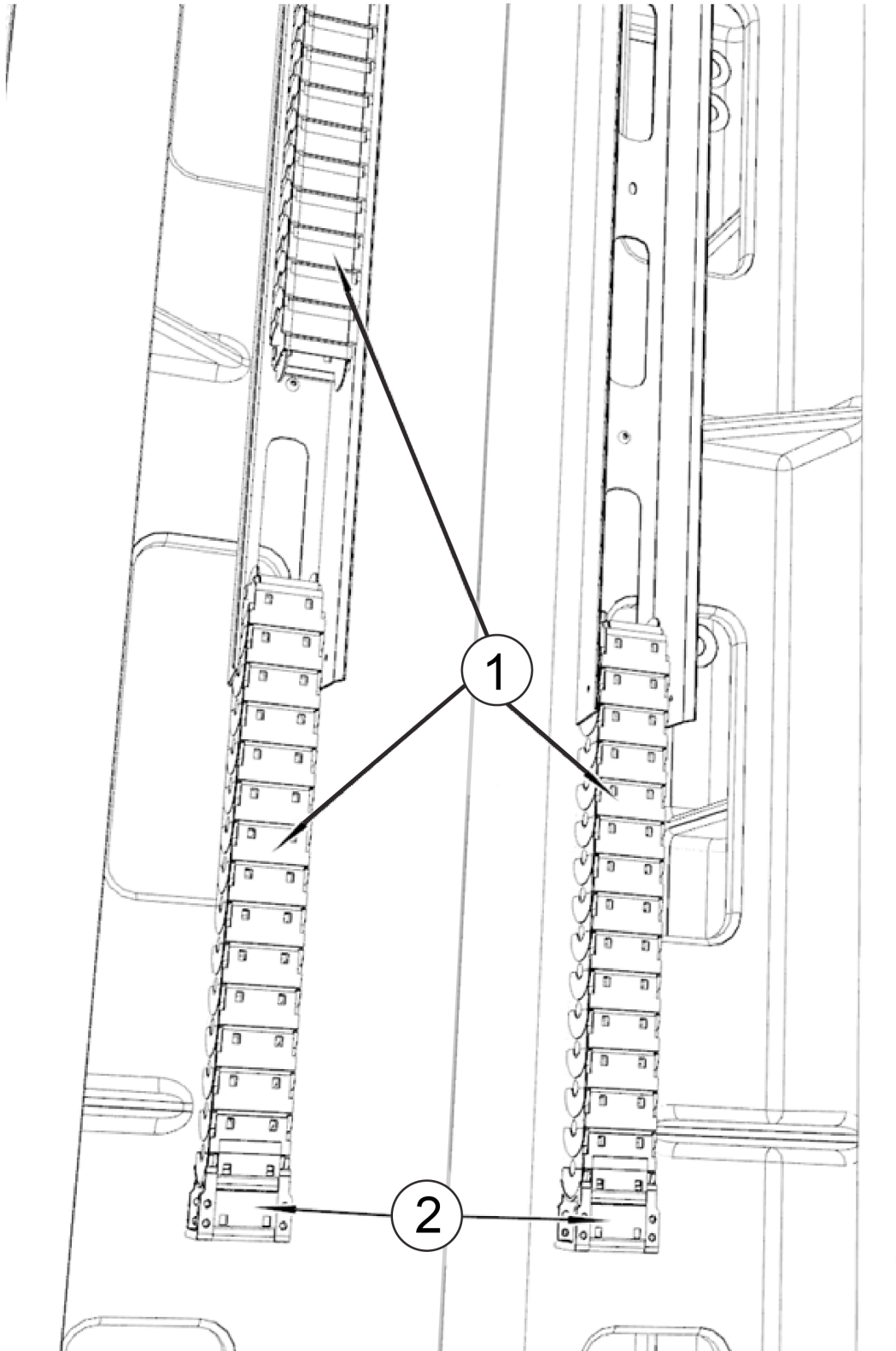

ITEM	PART #	DESCRIPTION
1	9219D	LINK, CABLE CARRIER TRACK
2	9219D	TRACK, CABLE CARRIER

## Column Components

### Bottom Linear Way Components

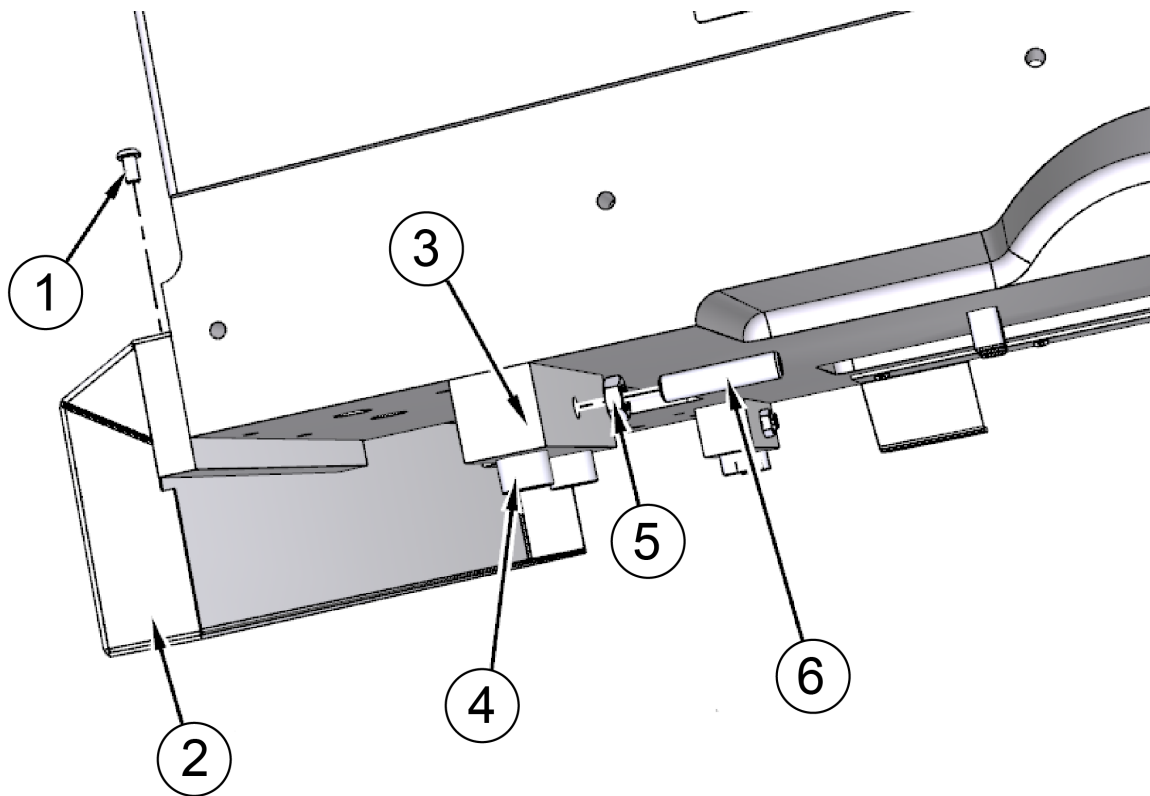

ITEM	PART #	DESCRIPTION
1	MF-90	SOCKET BUTTON HEAD SCREW 1/4-20 X 1/2"
2	10024K	COVER, LINEAR RAIL CARRIAGE
3	10043C	PUSH BLOCK, LINEAR RAIL CARRIAGE
4	MF-46E	SOCKET HEAD CAP SCREW 5/8-11 X 2 1/4"
5	MF-171	HEX JAM NUT 1/2-13 NC
6		1/2-13 X 2 1/4 SOCKET HEAD SET SCREW FLAT POINT

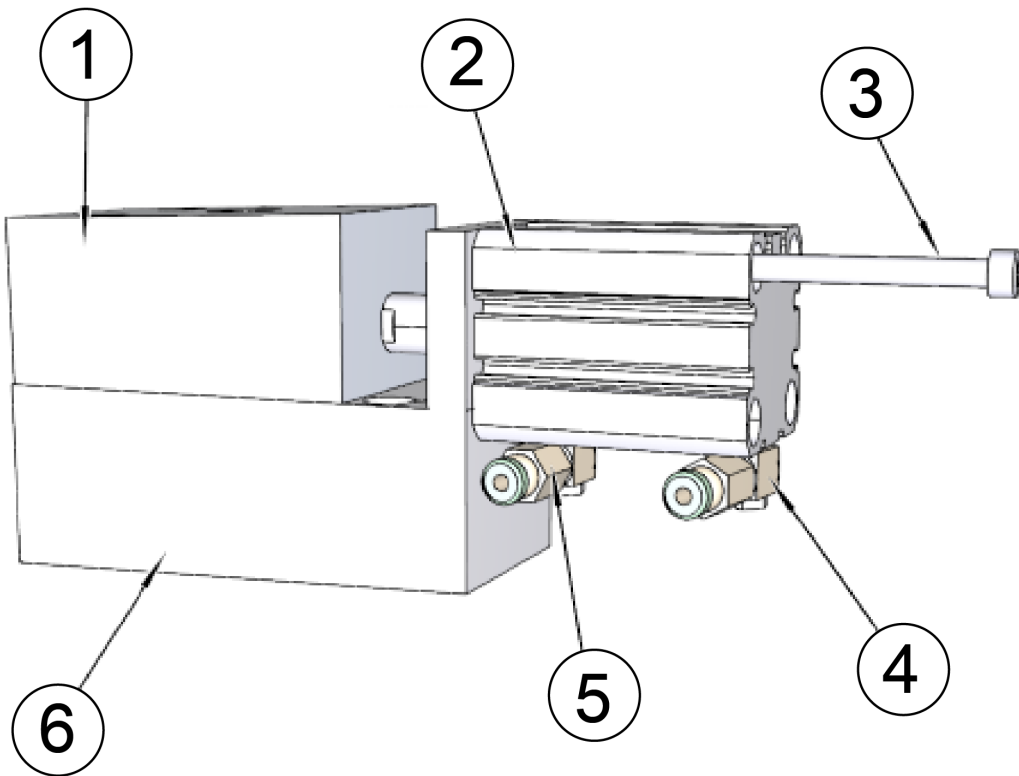
**Tilt Wedge Assembly**

ITEM	PART #	DESCRIPTION
1	10018H	TILT WEDGE, SPINDLE BASE
2	10018J	CYLINDER -SPINDLE BASE TILT
3	MF-7A	SOCKET HEAD CAP SCREW 10-24 X 2
4	514-4-16A	FITTING, ADJUSTABLE "L"
5	514-4-17J	CONNECTOR, MALE - 1/8" OD TO 10-32
6	10018G	BASE WEDGE, SPINDLE BASE TILT

**Lift Cylinders**

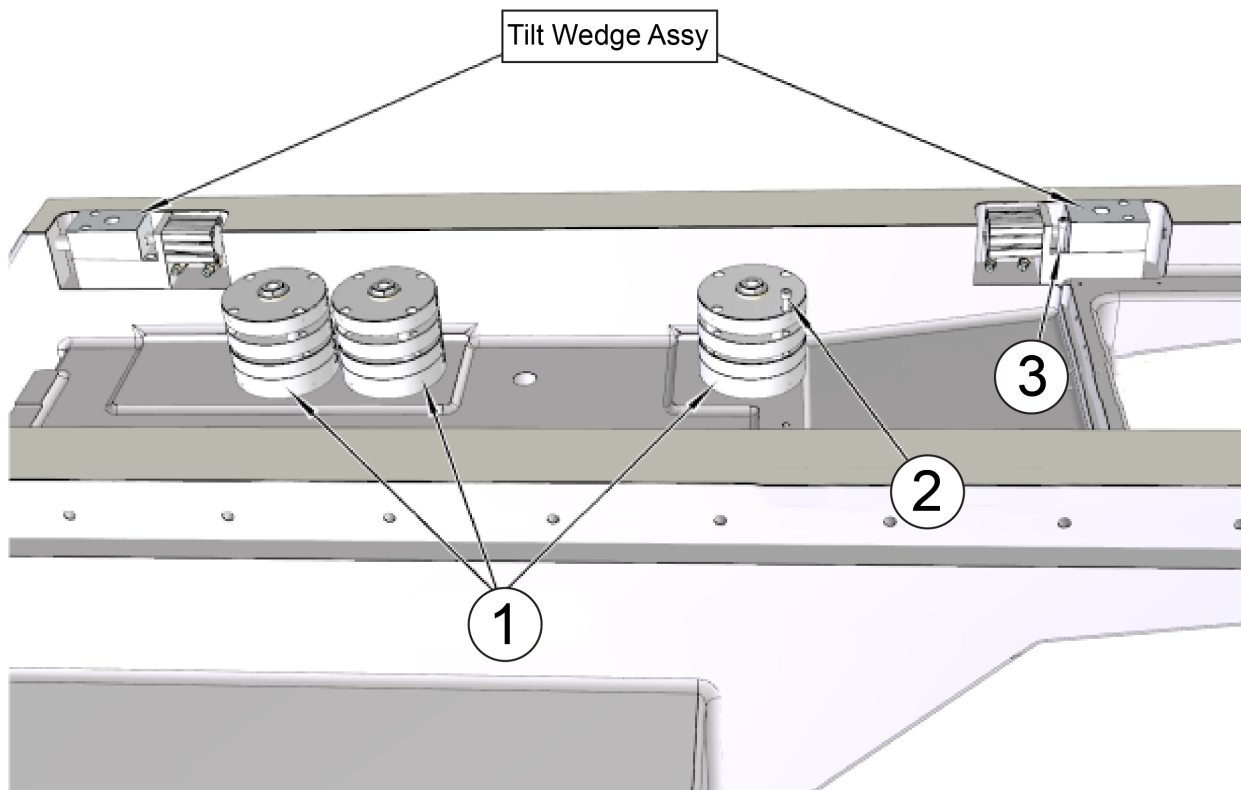

ITEM	PART #	DESCRIPTION
1	10018E	CYLINDER TILT/LIFT
2		1/4-20 X 5 1/2 SOCKET HEAD CAP SCREW
3		1/4-20 X 5 1/2 SOCKET HEAD CAP SCREW

## Shield and Wiper

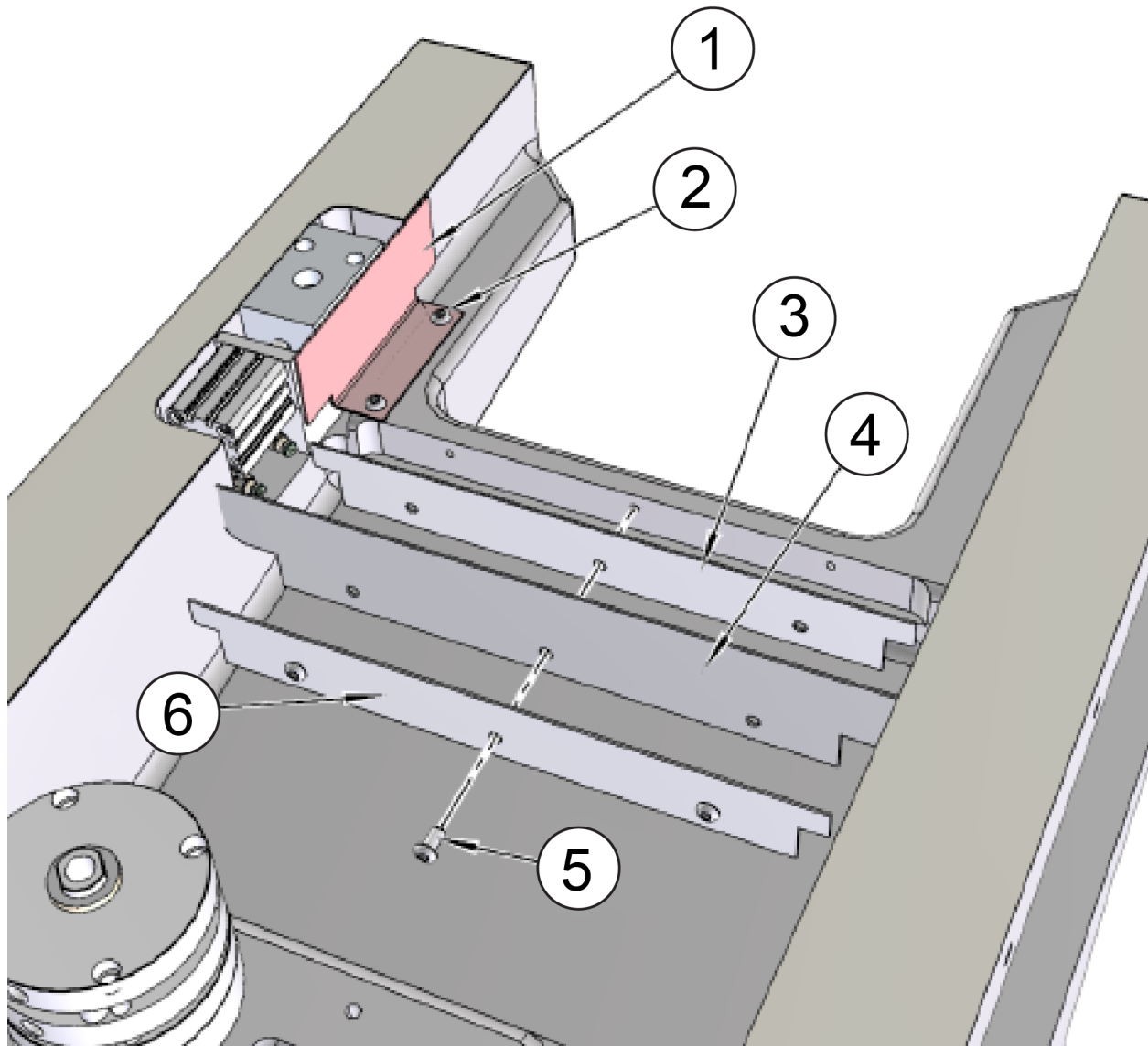

ITEM	PART #	DESCRIPTION
1	10013Q	COVER, WEDGE
2	MF-90	SOCKET BUTTON HEAD SCREW 1/4-20 X 1/2"
3	10013C	WIPER PLATE, Y-AXIS
4	10013D	RUBBER WIPER, Y-AXIS
5	MF-90	SOCKET BUTTON HEAD SCREW 1/4-20 X 1/2"
6	10013C	WIPER PLATE, Y-AXIS

## Oiler Door Components

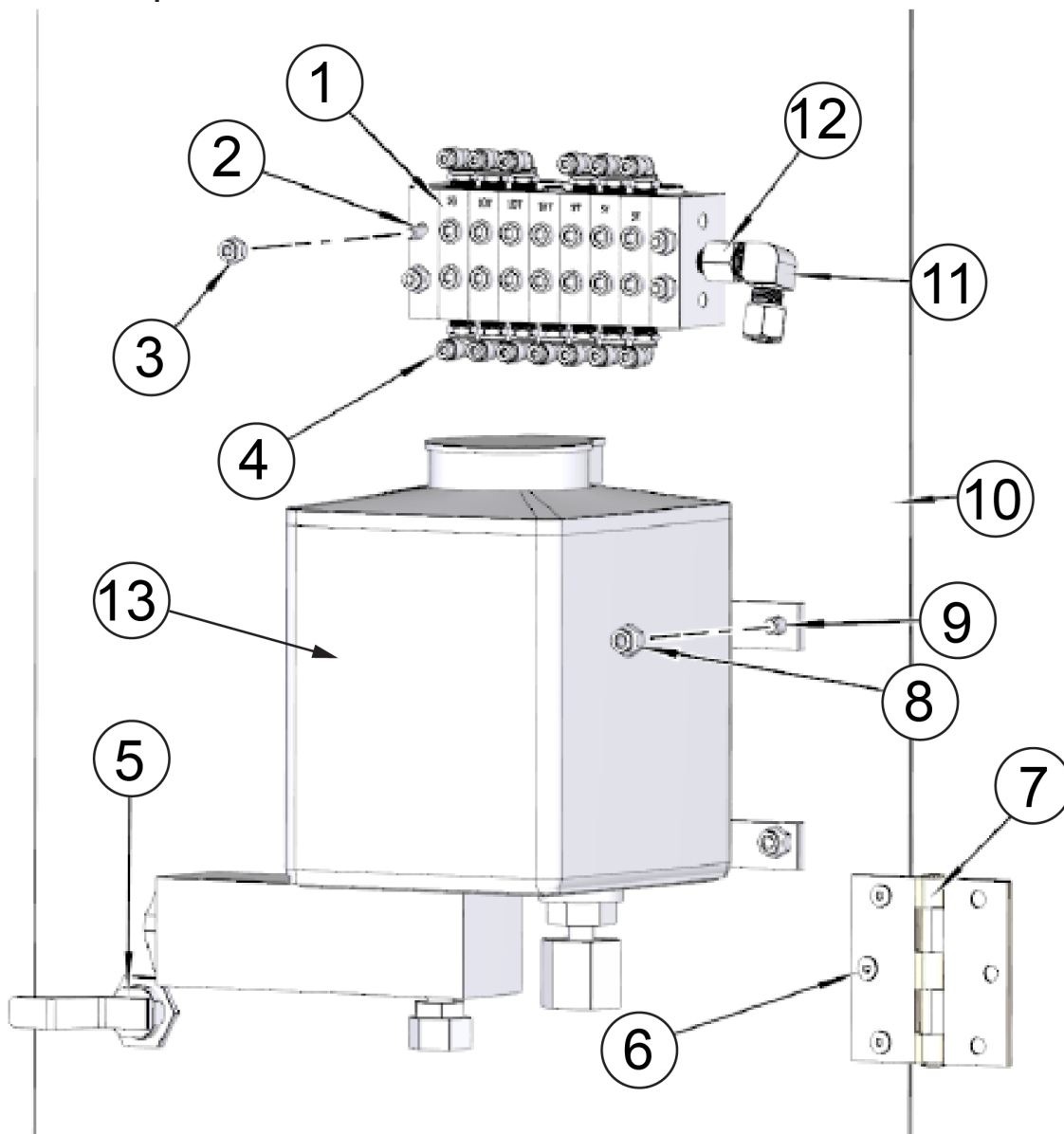

ITEM	PART #	DESCRIPTION
1	6349B	FEEDER, FLO-OILER
2	MF-7	SOCKET HEAD CAP SCREW 10-24 X 1 3/4"
3	MF-186B	NYLOCK NUTS 10-24
4	514-4-17A	FITTING, MALE PIPE 1/8 X 1/8"
5	9030A	
6		10-32 X 3/8 SOCKET FLAT HEAD SCREW
7	6340P	DOOR, ELECTRICAL ENCLOSURE
8	MF-186A	NYLOCK NUTS 1/4-20
9	MF-12	SOCKET HEAD CAP SCREW 1/4-20 X 1/2"
10	10013B	DOOR, COLUMN ACCESS
11	514-4-18H	FITTING 1/4 NPT X 3/8 TUBE 90 DEGREE
12	502-11-17L	ADAPTER, #120-B 1/4 TO 1/8" MALE PIPE FITTING
13	6363	PUMP, OIL DISTRIBUTION



### Solenoid Pack

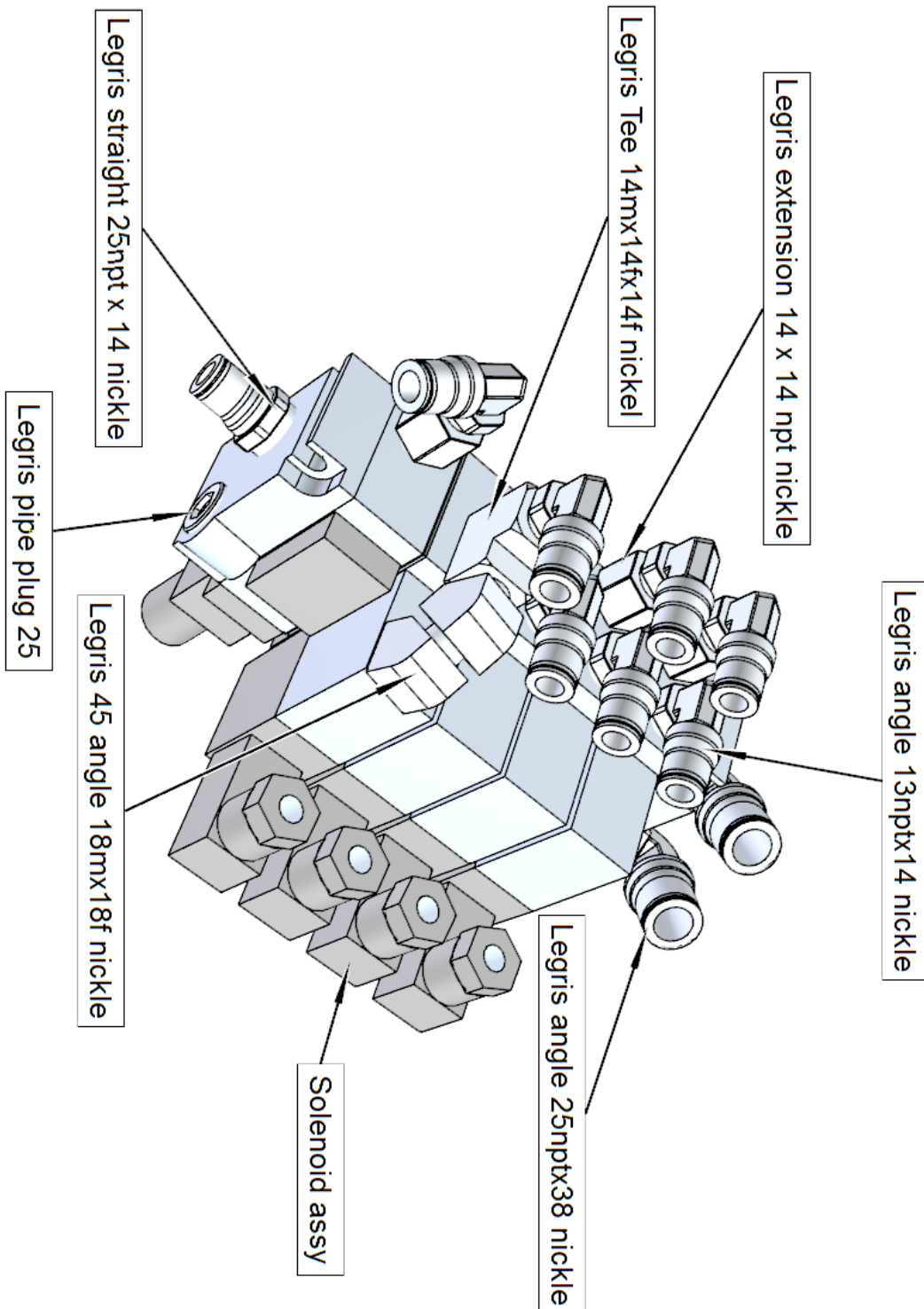

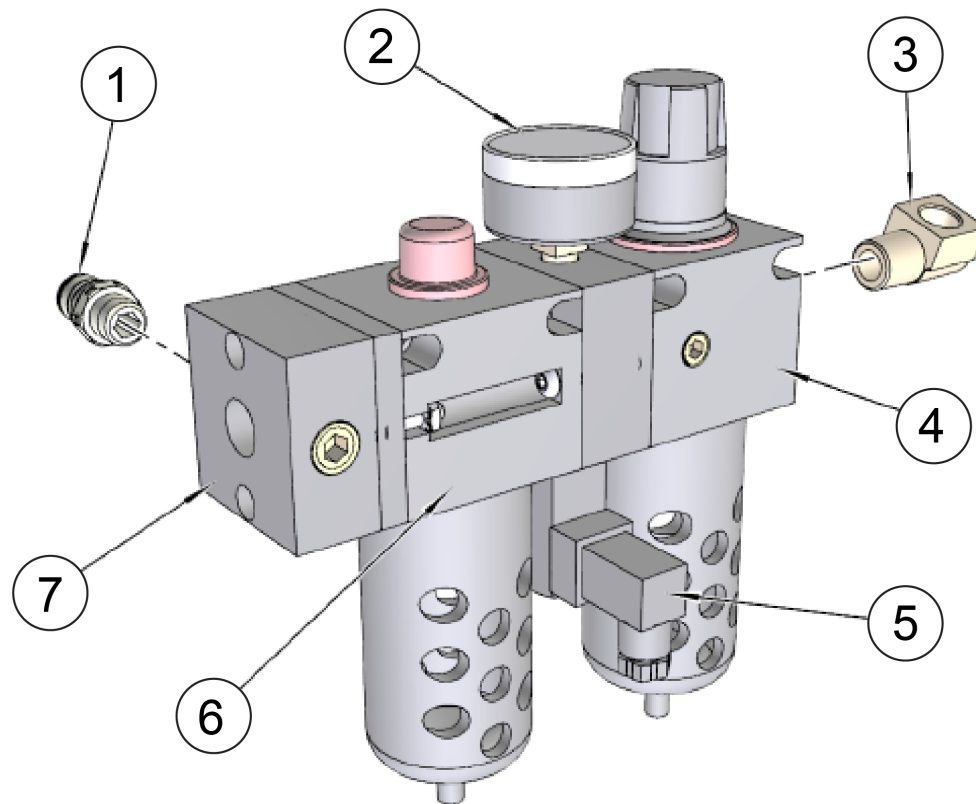
**Regulator/Filter Assembly**

ITEM	PART #	DESCRIPTION
1	514-4-17B	FITTING, MALE PIPE 1/4 X 1/8"
2	502-11-8	GAUGE, PRESSURE
3	502-11-17S	ELBOW, ST, 1/4 FPT X 1/4 MPT
4		FILTER ASSEMBLY
5		SOLENOID ASSEMBLY
6		REGULATOR ASSEMBLY
7		PORT BLOCK

### Outside Air Door Components

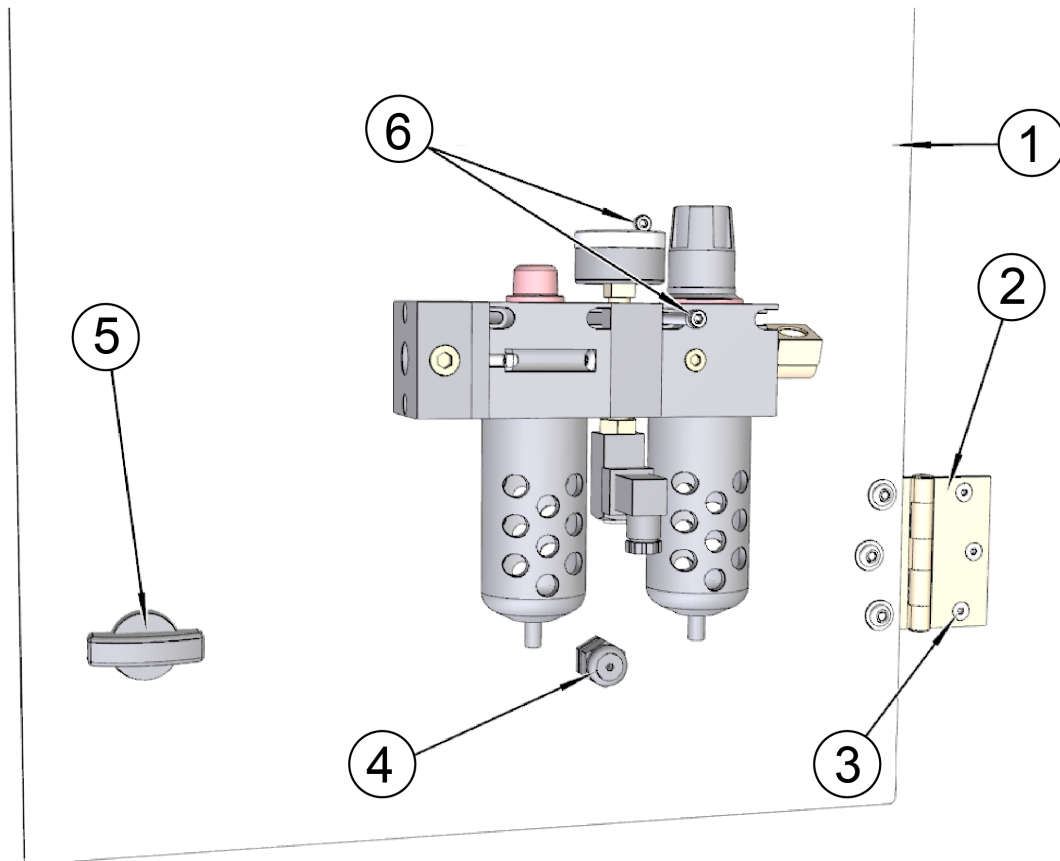

ITEM	PART #	DESCRIPTION
1	10013	DOOR, COLUMN ACCESS(AIR SUPPLY)
2	6340P	HINGE, AIR ACCESS DOOR
3		10-24 X 1/4 FLATHEAD SOCKET CAP SCREW
4	502-37-71N	STRAIN RELIEF
5	9030E	DOOR LATCH ,COLUMN AND AIR ACCESS
6		10-24 X 1 1/2 SOCKET HEAD CAP SCREW

**Inside Air Door Components**

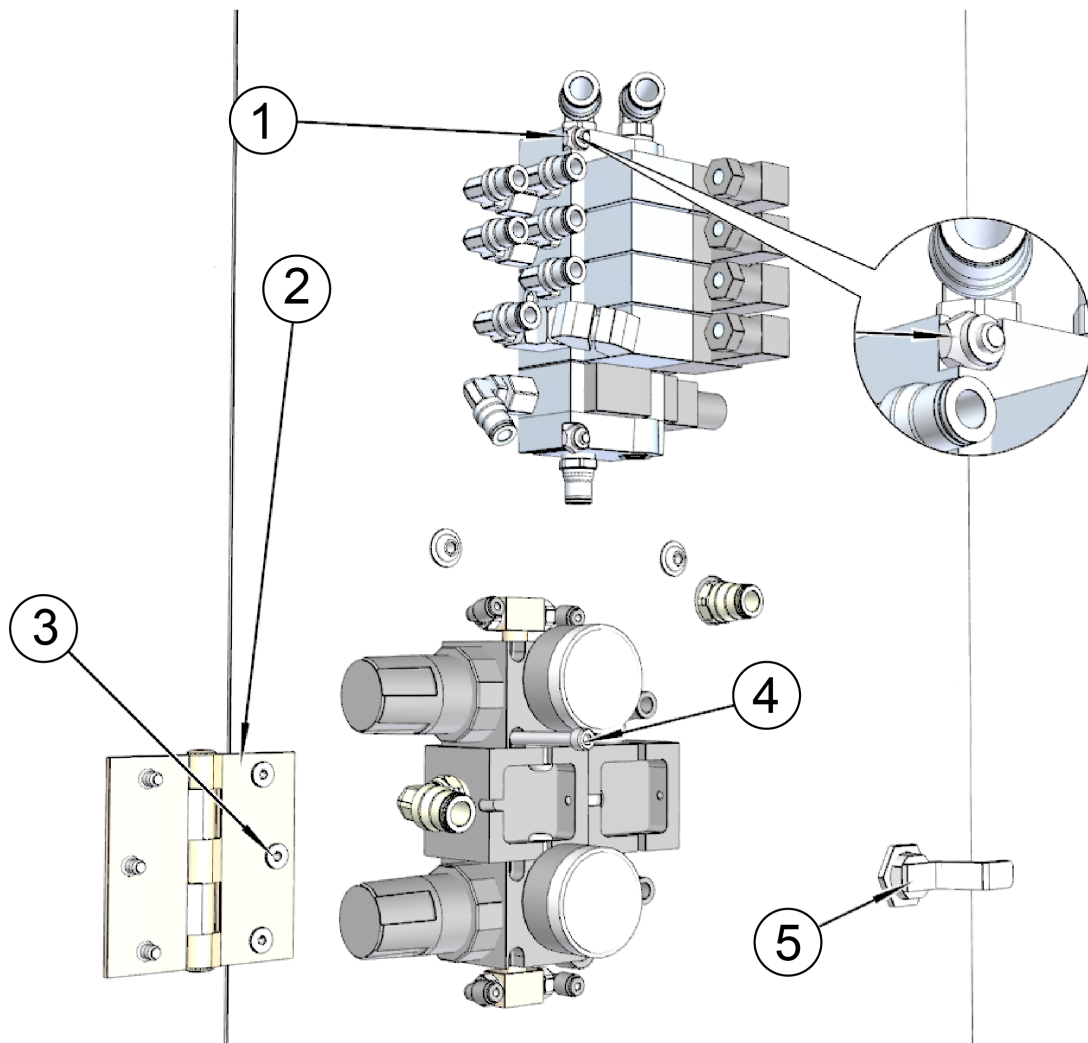

ITEM	PART #	DESCRIPTION
1	MF-186B	NYLOCK NUTS 10-24
2	6340P	HINGE, AIR ACCESS DOOR
3		10-32 X 3/8 FLATHEAD SOCKET CAP SCREW
4	MF-7	SOCKET HEAD CAP SCREW 10-24 X 1 3/4"
5	9030E	DOOR LATCH ,COLUMN AND AIR ACCESS

**Y-Axis Drive Components**

Idle End

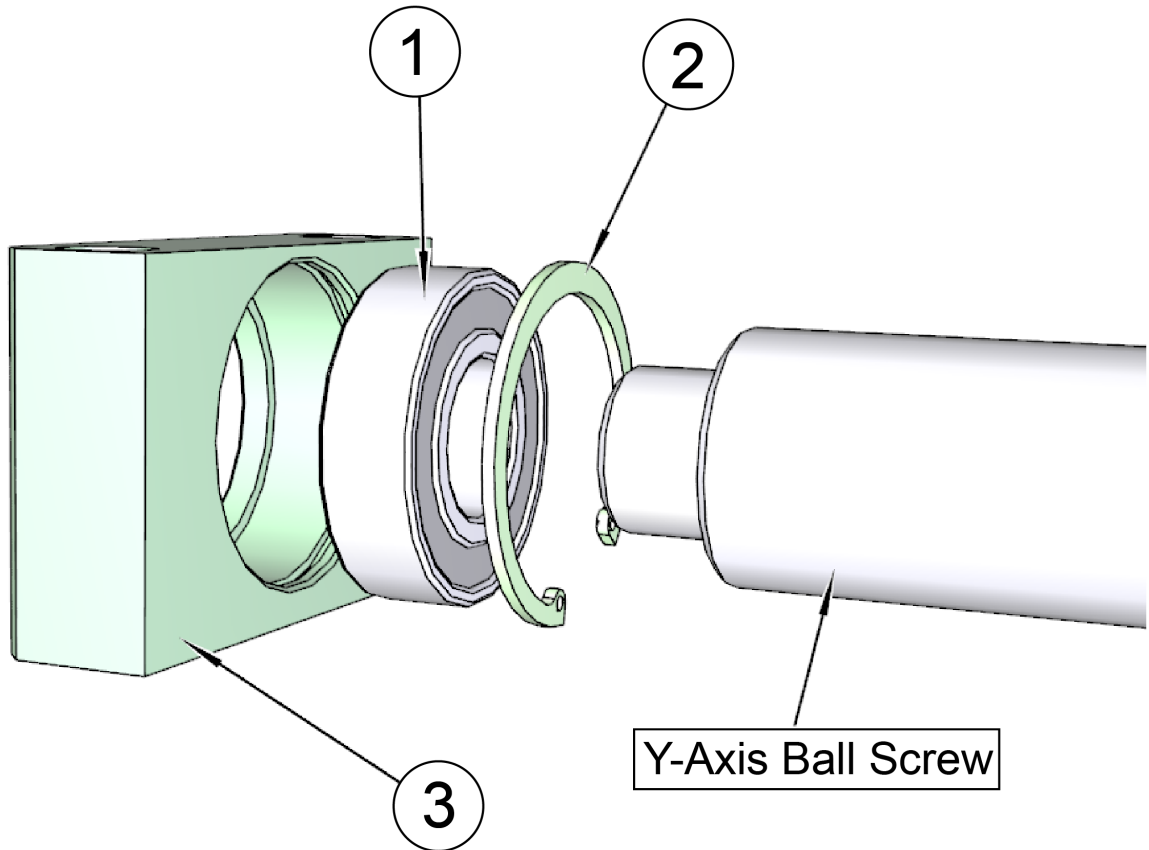

ITEM	PART #	DESCRIPTION
1	6778D	BEARING
2	7245E	RETAINING RING
3	9001A	BALLSCREW SUPPORT-Y AXIS

### Motor Housing Components

See Maintenance Section for correct bearing installation procedure.

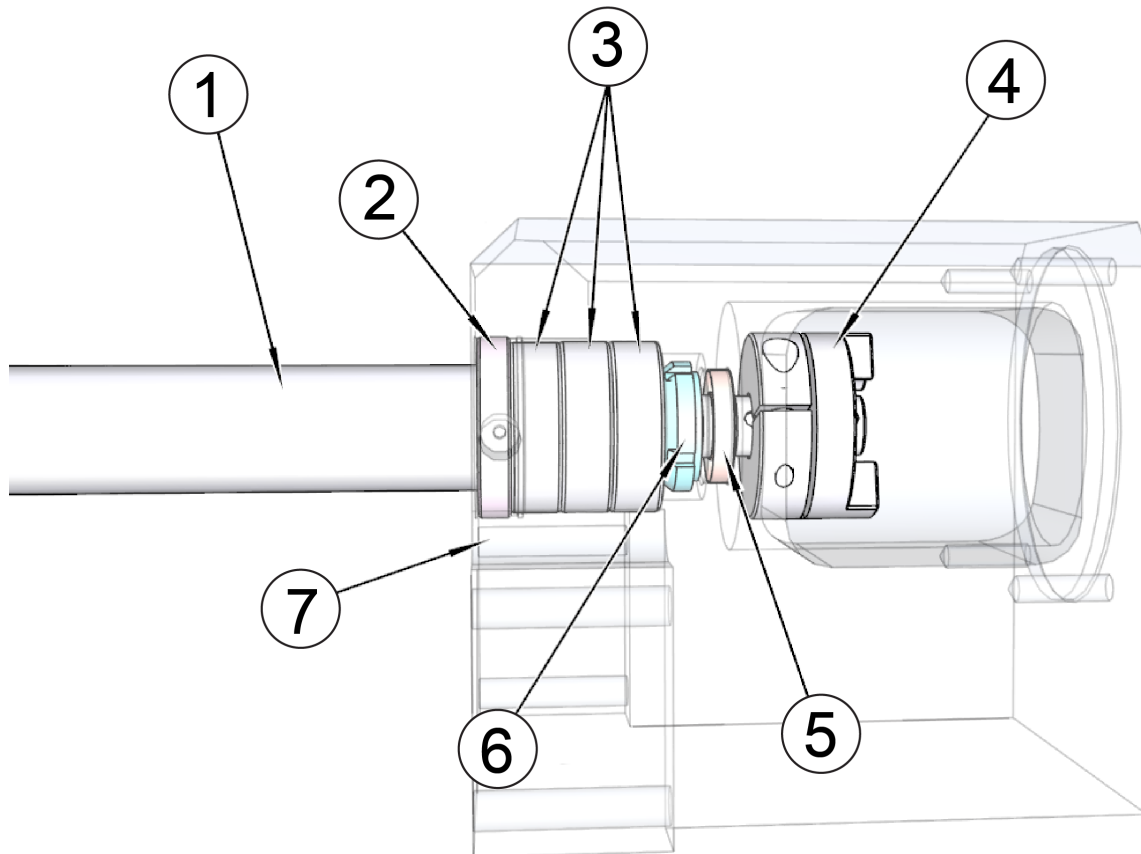

ITEM	PART #	DESCRIPTION
1	10023	Y-AXIS BALLSCREW ASSEMBLY
2	504-34-15A	NUT, THRUST BEARING
3	504-34-52	BEARING, ANGULAR CONTACT BALL
4	9001P	COUPLING ASSEMBLY
5	504-34-53	OIL SEAL
6	504-34-54	LOCKNUT BEARING
7	9001N	BALLSCREW SUPPORT/ DRIVE HOUSING

### Motor Components

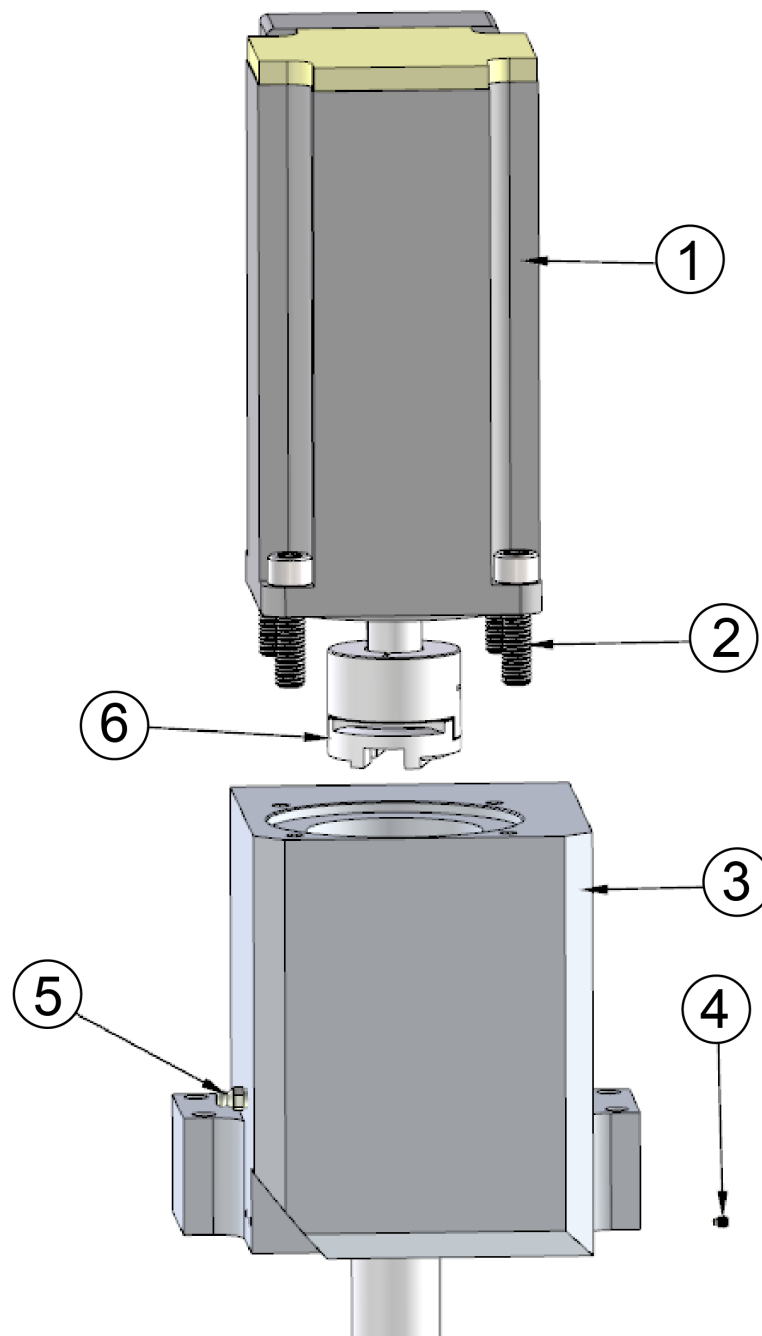

ITEM	PART #	DESCRIPTION
1	6481G	MOTOR, AC SERVO
2	MF-44A	SOCKET HEAD CAP SCREW 1/2-13 X 1 3/4"
3	9001N	BALLSCREW SUPPORT/ DRIVE HOUSING
4	100-82-2	SCREW,SET-BRASS GIB - 3/16" LONG
5	MF-191A	5/16-32 STRAIGHT LUBE GREASE FITTING
6	9001P	COUPLING ASSEMBLY

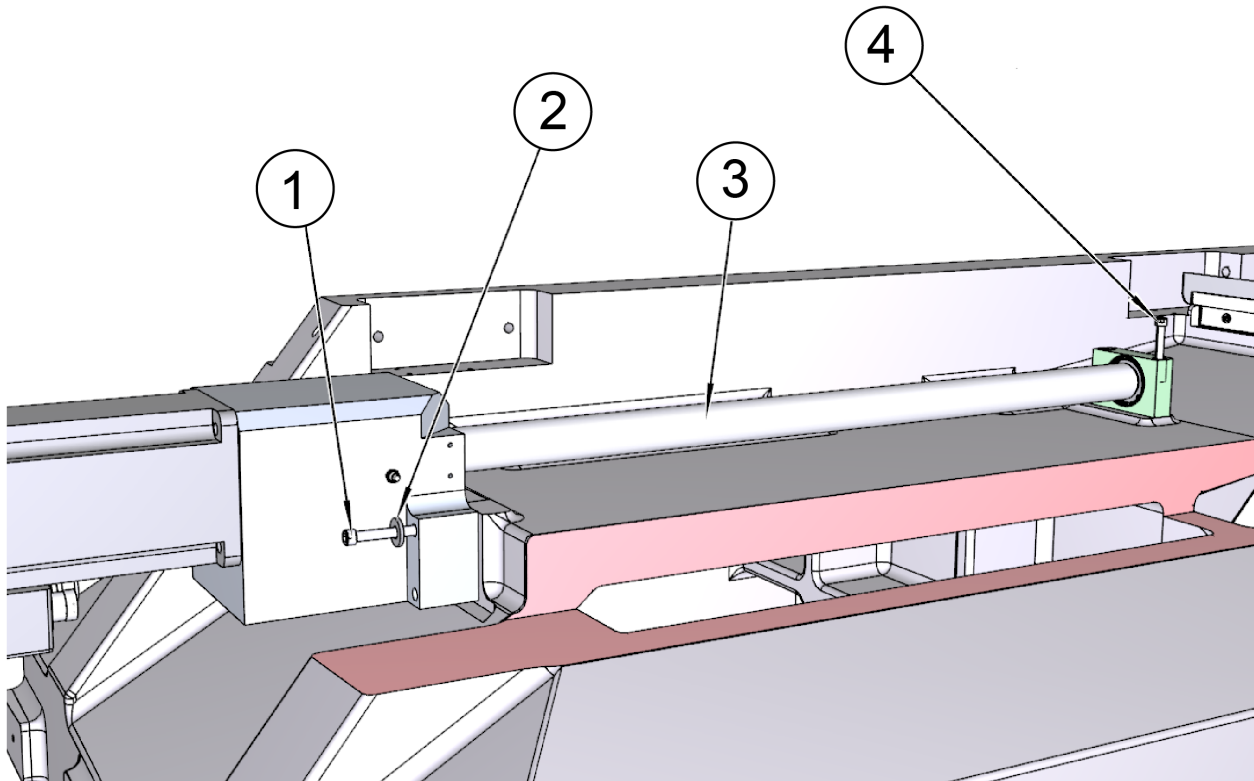
**Y-Axis Mounting**

ITEM	PART #	DESCRIPTION
1	MF-27C	SOCKET HEAD CAP SCREW 5/16-18 X 2 1/4"
2	100-28-18	WASHER, FLAT
3	10023	Y-AXIS BALLSCREW ASSEMBLY
4	MF-27	SOCKET HEAD CAP SCREW 5/16-18 X 2"



### Spindle Base Tower and Cable Cylinder

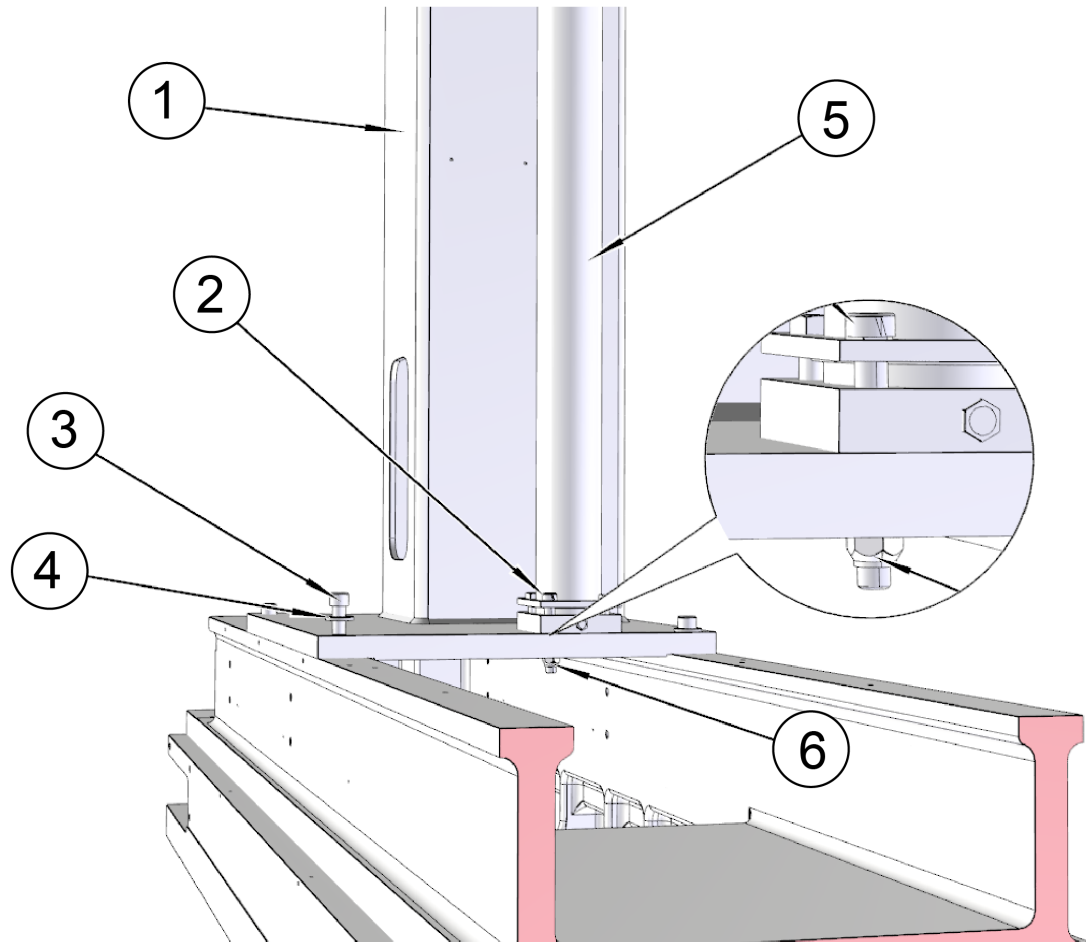

ITEM	PART #	DESCRIPTION
1	10014D	TOWER
2	MF-28E	SOCKET HEAD CAP SCREW 5/16-18 X 3 "
3	MF-44A	SOCKET HEAD CAP SCREW 1/2-13 X 1 3/4"
4	100-19A	WASHER, HARDENED 17/32" ID
5	10021A	CABLE CYLINDER
6	MF-187	NYLOCK NUTS 5/16-18 NC

## Inner Spindle Components

### Lower Section Components

See Maintenance Section to correct bearing installation procedure.

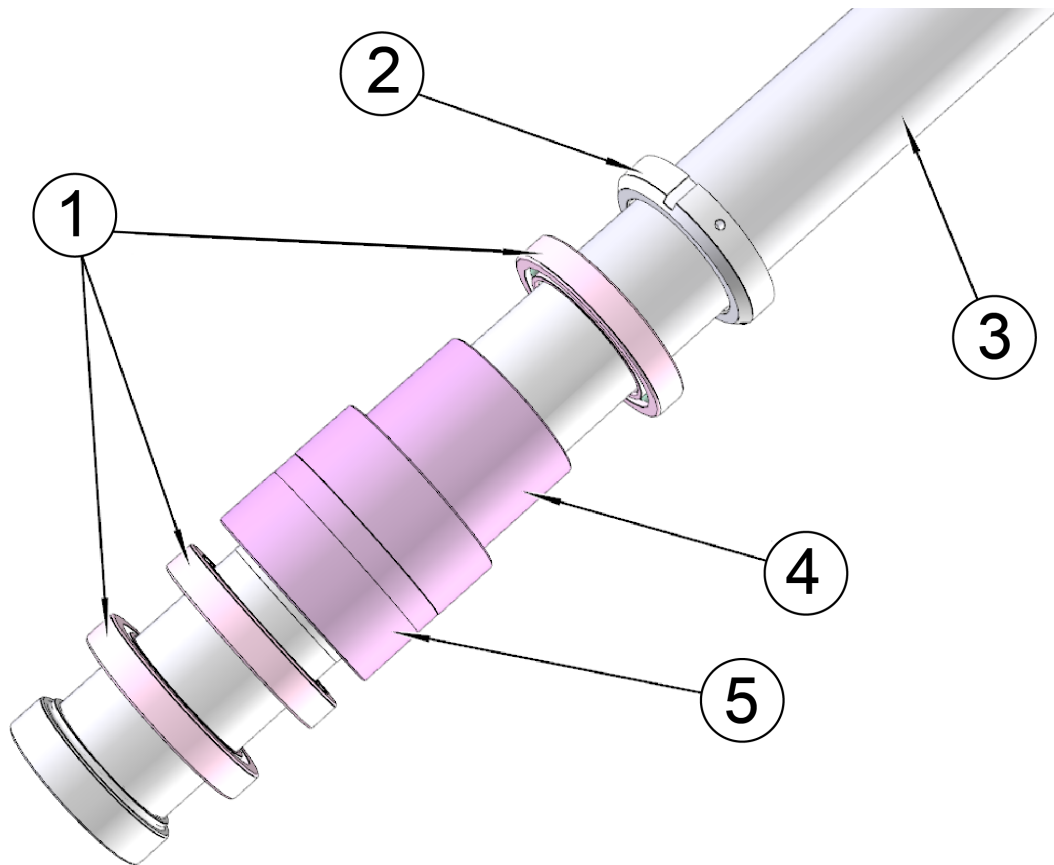

ITEM	PART #	DESCRIPTION
1	6116E	BEARING,PRECISION- SPINDLE (SET OF 3)
2	6116F	NUT,BEARING-LOWER INNER SPINDLE (SHOELOK)
3	10001D	INNER SPINDLE ASSEMBLY
4	6172C	SPACER,PRECISION BEARING INNER SPINDLE
5	6172D	SPACER,PRECISION BEARING OUTER SPINDLE

### Upper Section Components

See Maintenance Section for correct Belleville washer installation procedure.

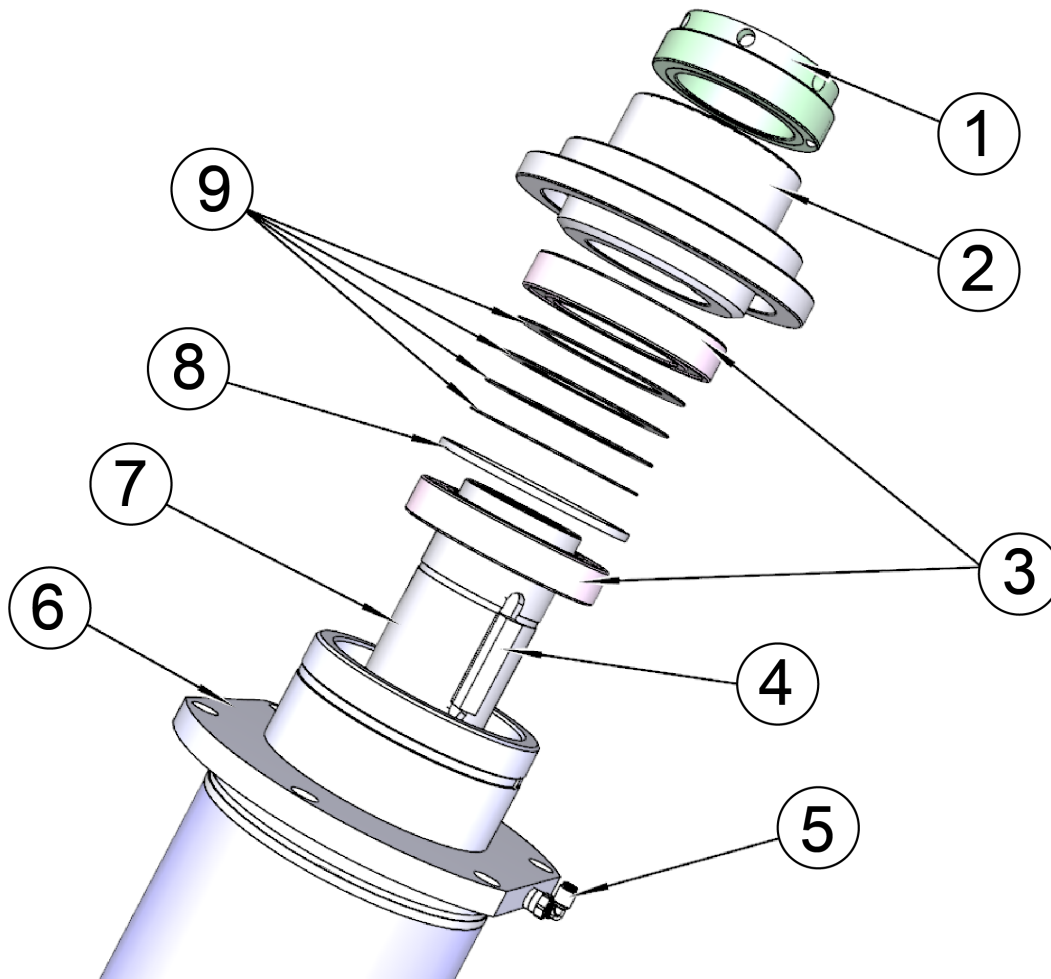

ITEM	PART #	DESCRIPTION
1	9218A	NUT, SPINDLE ADJUSTMENT
2	9218	INDEX BUSHING-DRIVEN SPROCKET
3	6115A	BEARING, UPPER SPINDLE
4	6090B	KEY, SQUARE SPINDLE DRIVE
5	514-4-18	ELBOW-90 DEGREE 1/8 POLY TO 1/8NPT
6	10001P	OUTER SPINDLE ASSEMBLY
7	10001D	INNER SPINDLE ASSEMBLY
8	6123F	SPACER, OUTER SPINDLE-UPPER HOUSING
9	6113	SPRING, BELLEVILLE

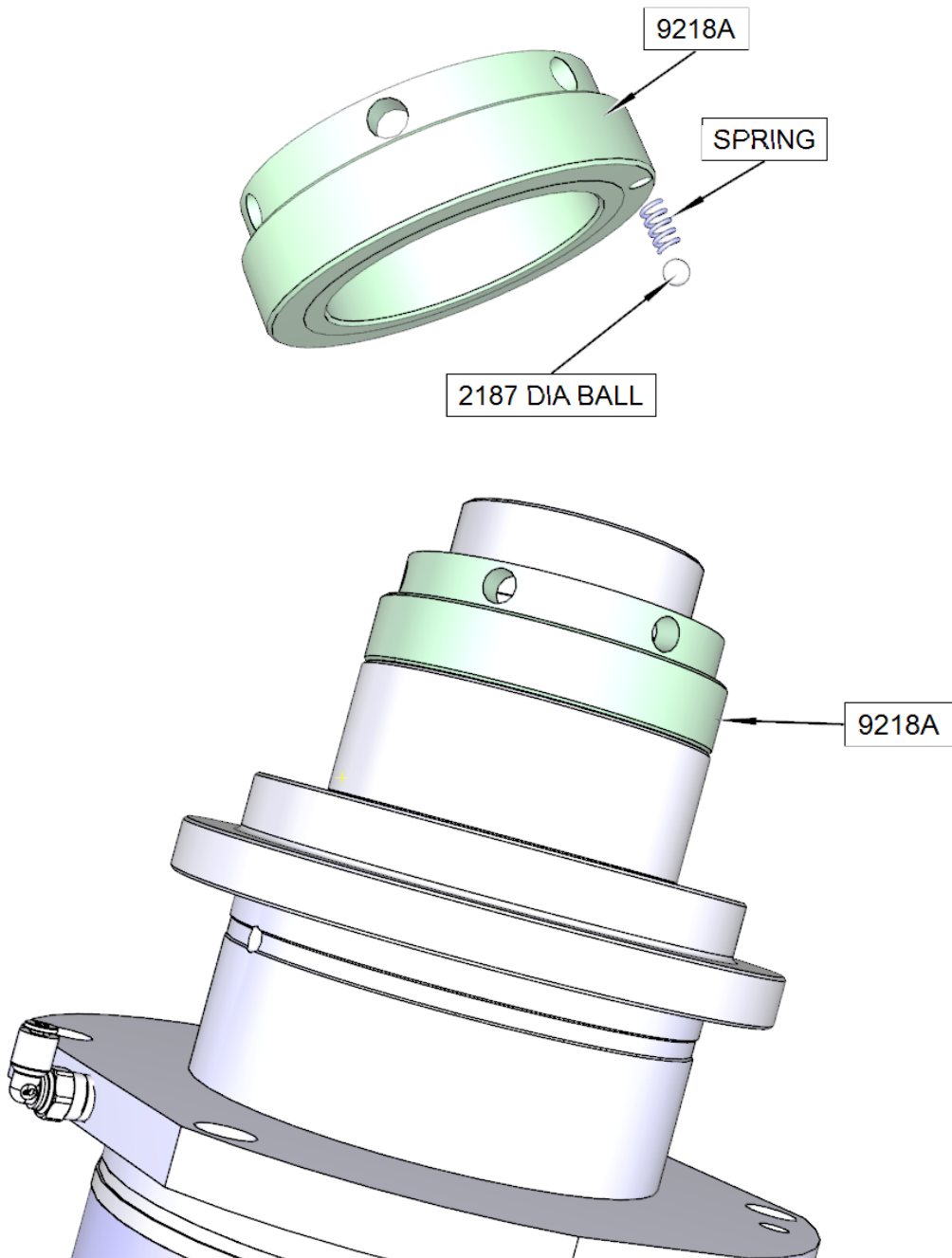

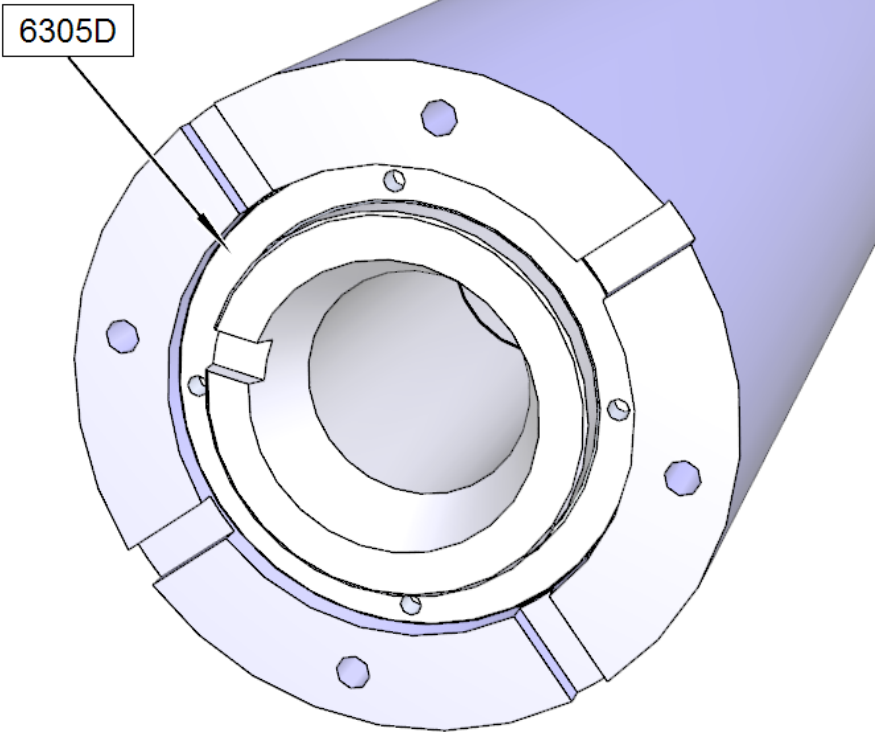

## Drawbar Components

### Upper Section

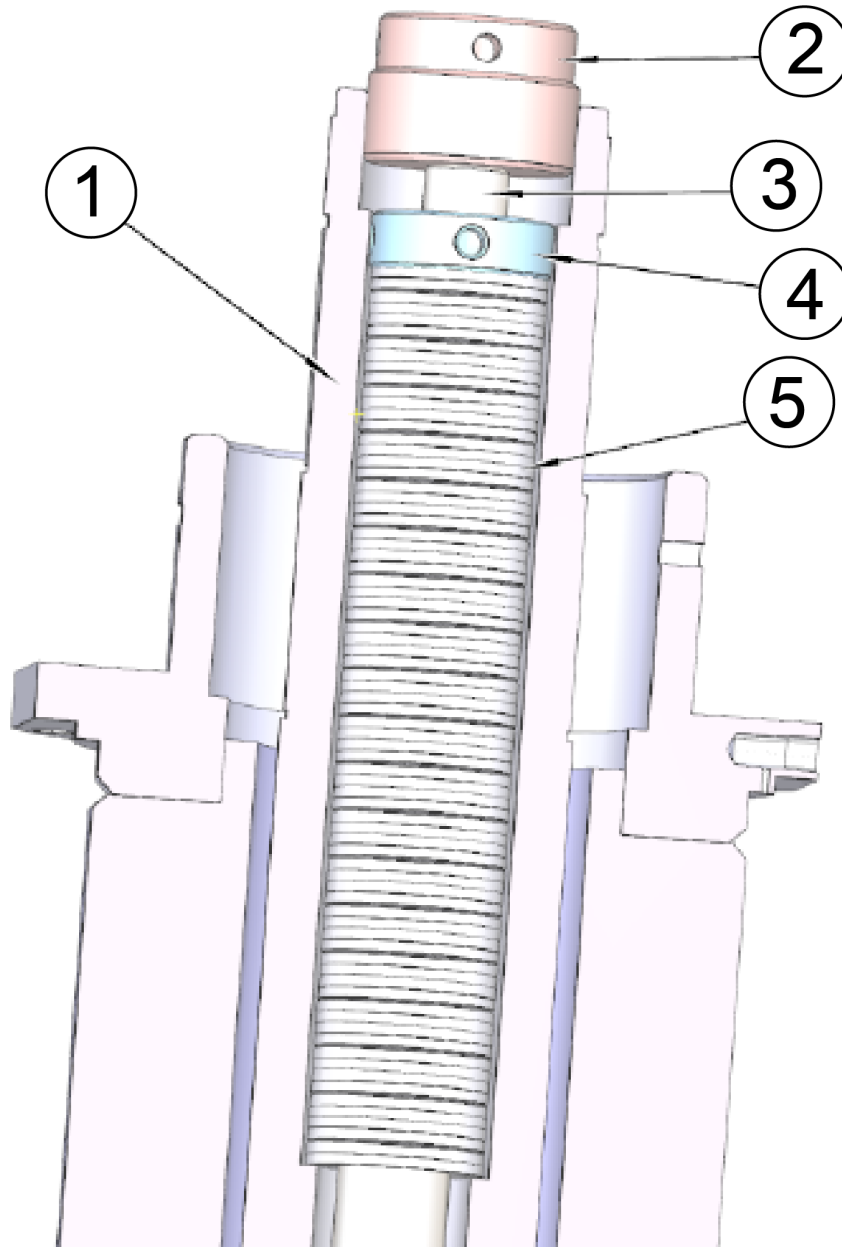

ITEM	PART #	DESCRIPTION
1	10001S	TUBE, INNER SPINDLE HSK
2	10041B	NUT, HSK DRAWBAR TOP
3	10041A	SHAFT, DRAWBAR
4	10041C	DRAWBAR, SPRING RETAINER HSK
5	10041	BELLEVILLE SPRING, DRAWBAR

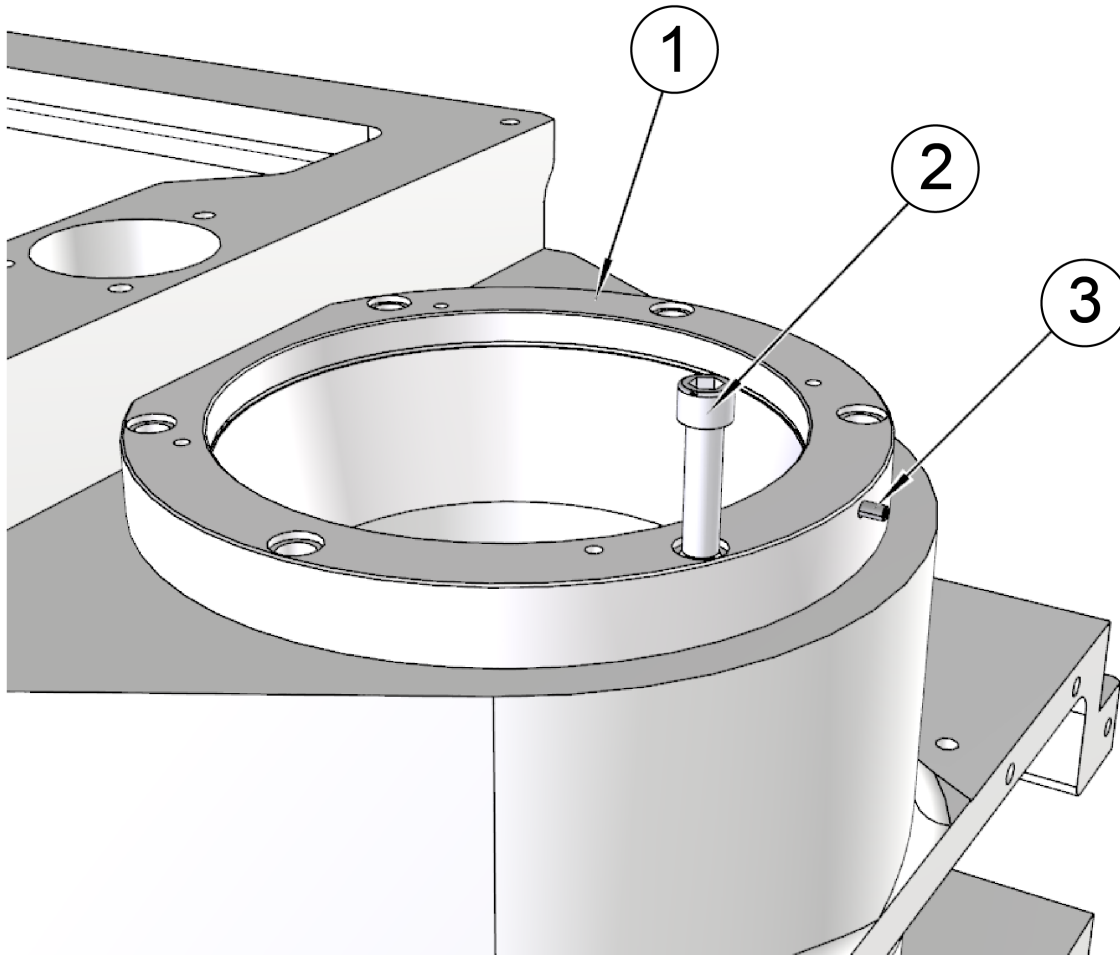
**Spindle Base Components****Upper Spindle Bushing Carrier**

ITEM	PART #	DESCRIPTION
1	10001A	CARRIER, BEARING
2	MF-33	SOCKET HEAD CAP SCREW 3/8-16 X 1 1/2"
3	100-82-2B	SCREW, SET-BRASS TIPPED (8-32 X 3/8")

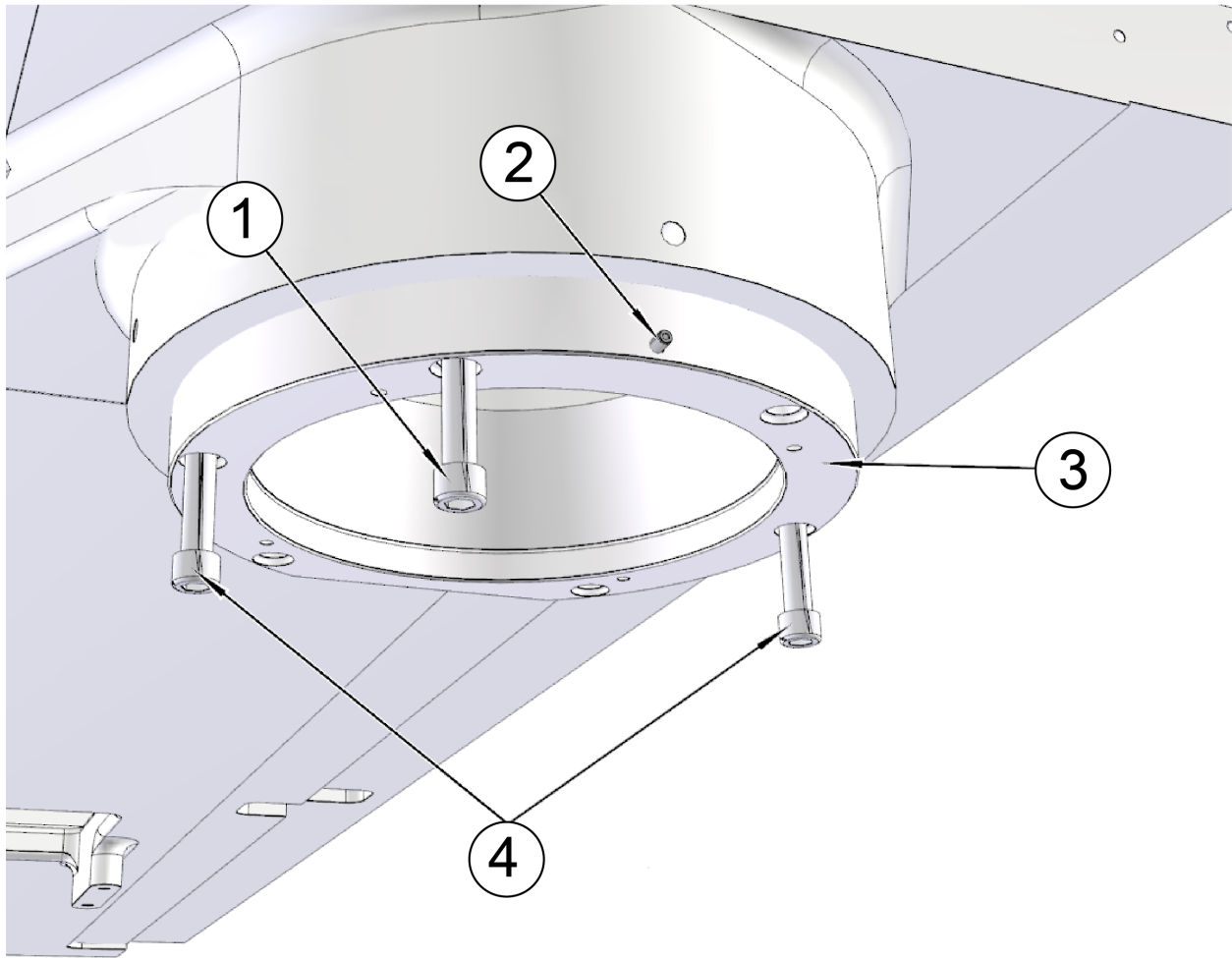
**Lower Spindle Bushing Carrier**

ITEM	PART #	DESCRIPTION
1	MF-33	SOCKET HEAD CAP SCREW 3/8-16 X 1 1/2"
2	100-82-2B	SCREW, SET-BRASS TIPPED (8-32 X 3/8")
3	10001A	CARRIER, BEARING
4	MF-32	SOCKET HEAD CAP SCREW 3/8-16 X 1 1/4"

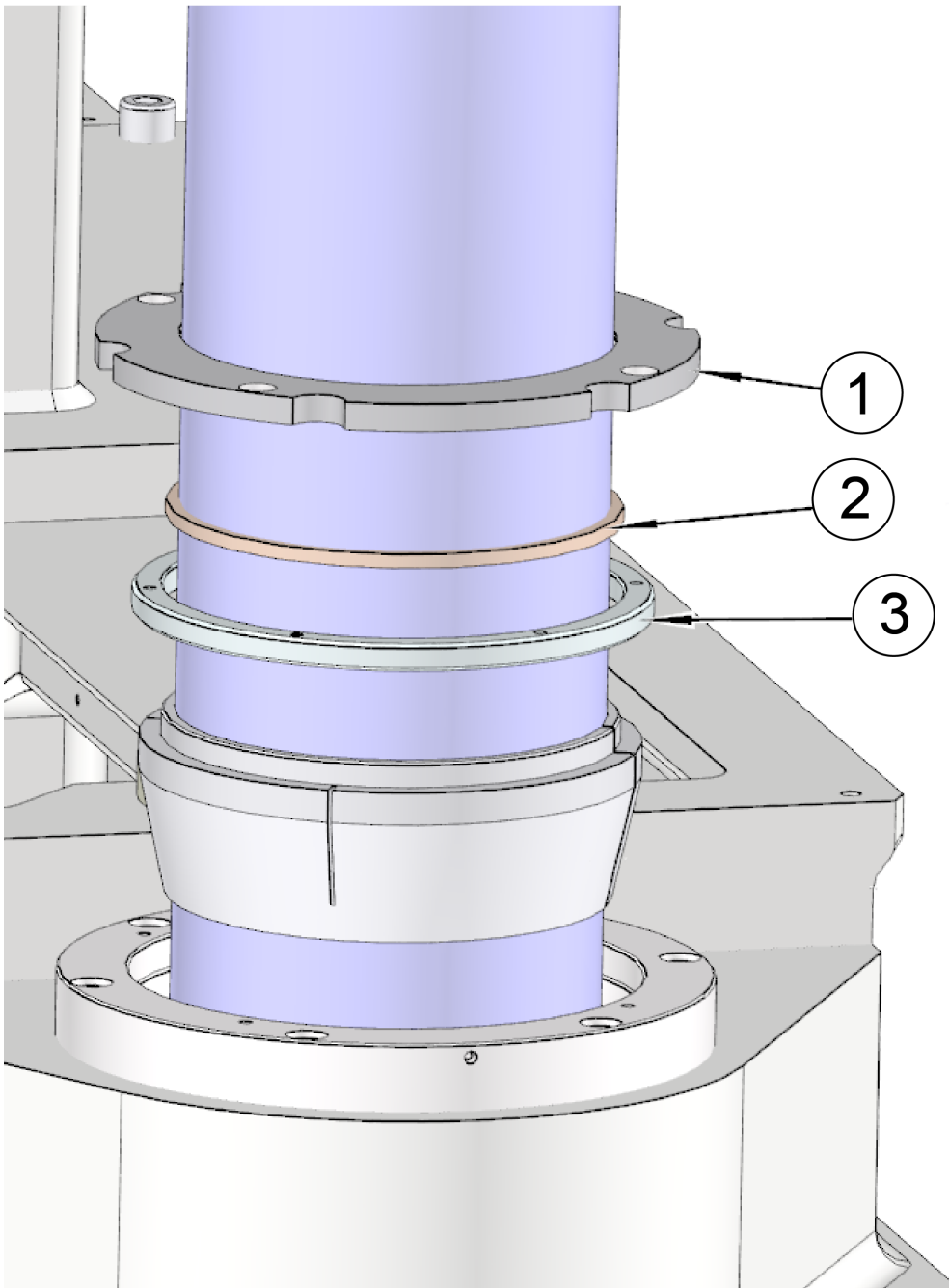

**Upper Spindle Bushing Components**

ITEM	PART #	DESCRIPTION
1	10005A	RETAINER, WIPER
2	10001J	FELT OILER
3	10001H	NUT, OUTER SPINDLE BUSHING

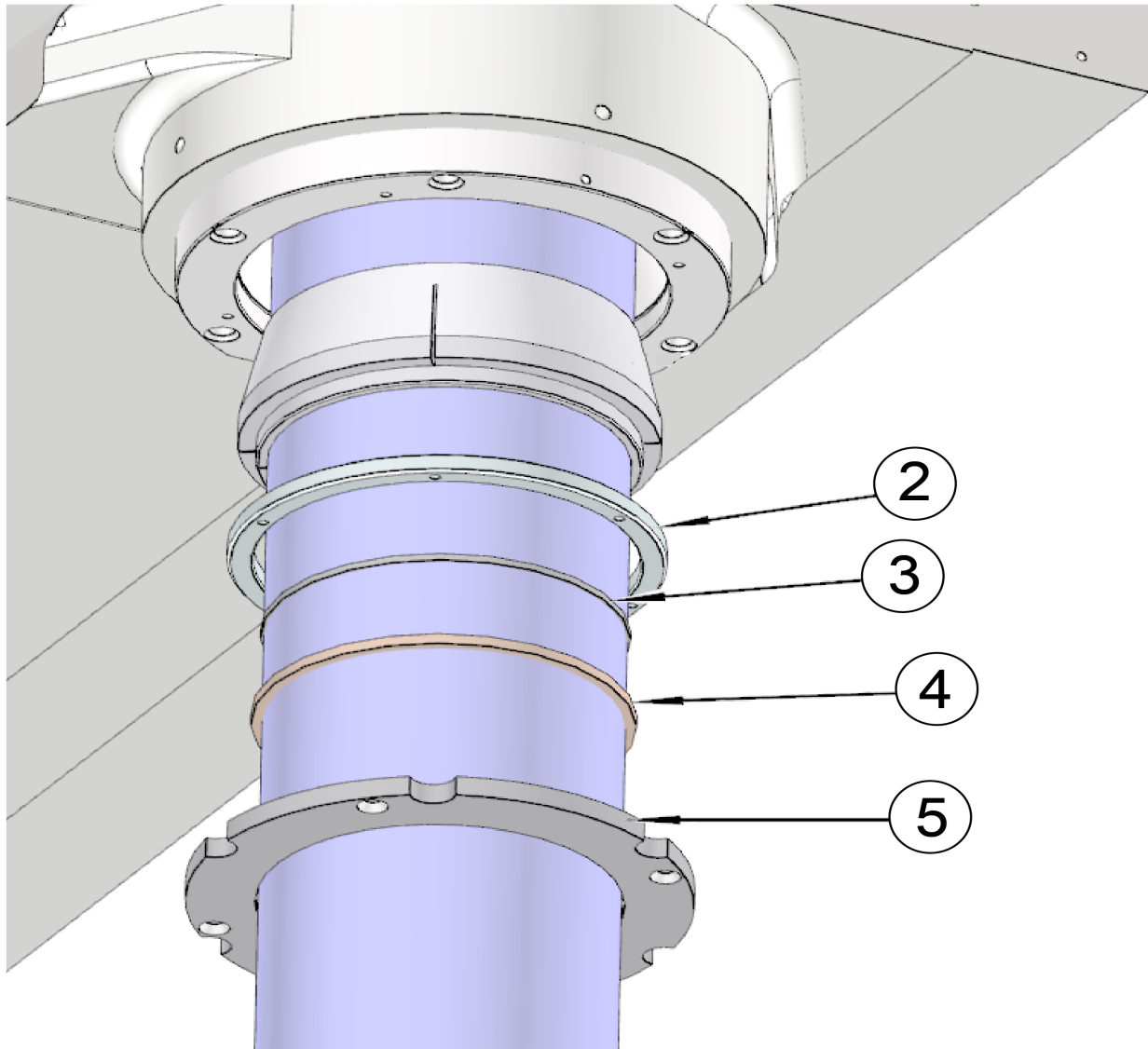
**Lower Spindle Bushing Components**

ITEM	PART #	DESCRIPTION
2	10001H	NUT, OUTER SPINDLE BUSHING
3	10001K	SQUARE O-RING, OUTER SPINDLE
4	10001J	FELT OILER , OUTER SPINDLE
5	10005A	RETAINER, WIPER

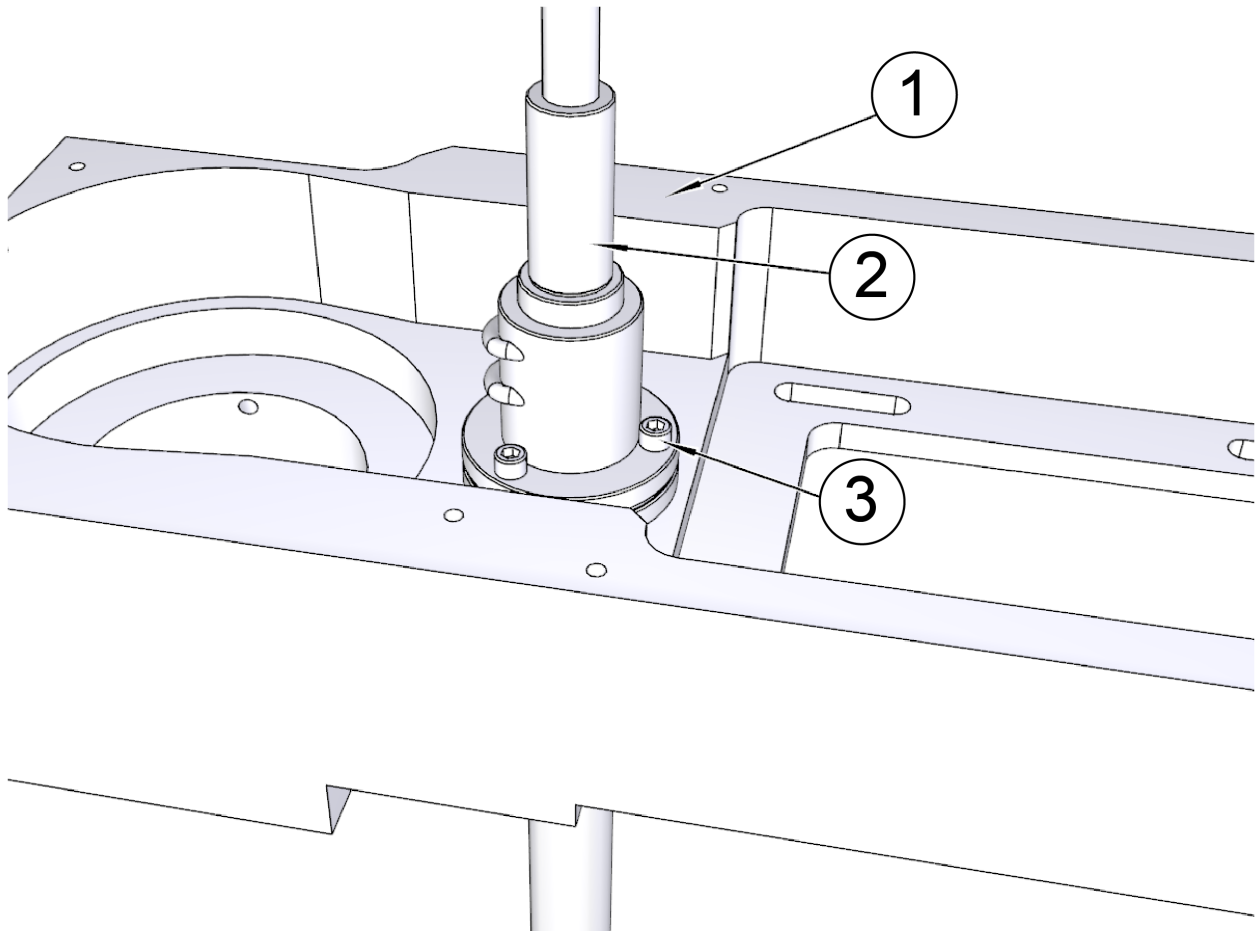
**Z-Axis Assembly****Ballscrew Nut to Motor Housing Components**

ITEM	PART #	DESCRIPTION
1	9216	HOUSING,UPPER SPINDLE DRIVE
2	10023C	VERTICAL BALLSCREW ASSEMBLY
3	MF-25	SOCKET HEAD CAP SCREW 5/16-18 X 1 1/2"

### Lower Section Components

See Maintenance Section for correct bearing and Belleville installation procedure.

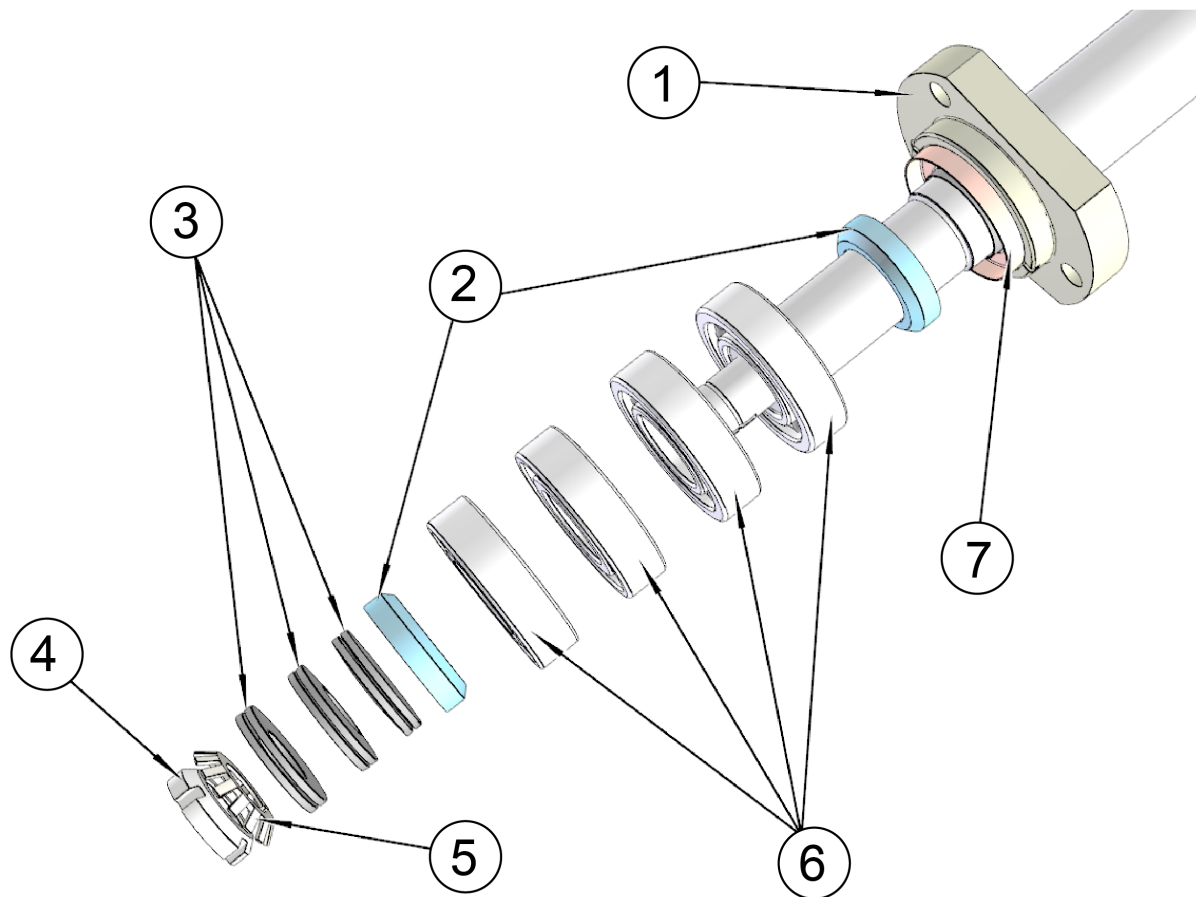

ITEM	PART #	DESCRIPTION
1	6032E	RETAINER, THRUST BEARING
2	6107	RING, SHOULDER-SPINDLE FEED
3	6037A	SPRING, FEED SHAFT & COLUMN BUMPER
4	502-10-17	NUT, LOCK
5	502-10-18	WASHER, LOCK
6	6063	BEARING, ANGULAR CONTACT BALL
7	6052	SEAL, OIL-UPPER BALLSCREW

### Upper Section Components

See Maintenance Section for correct Belleville installation procedure.

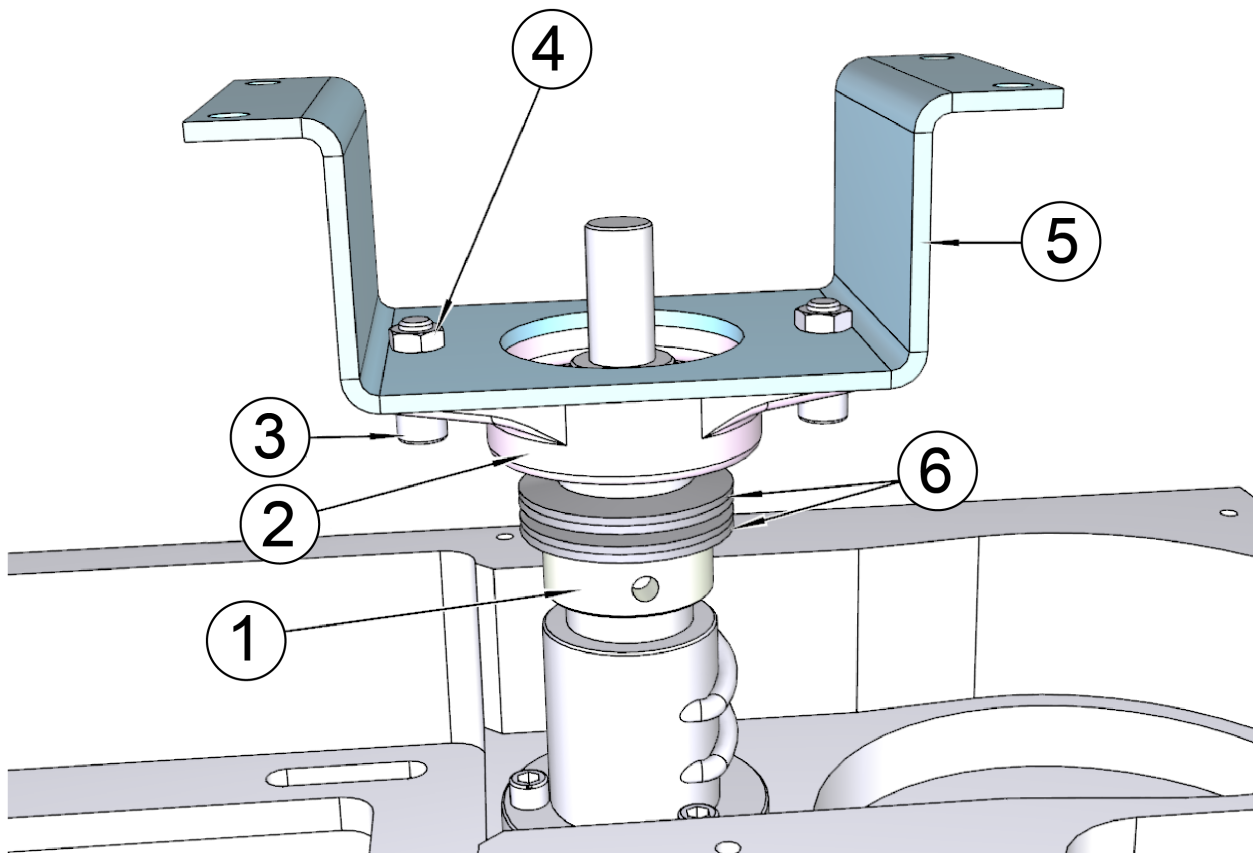

ITEM	PART #	DESCRIPTION
1	6037D	COLLAR, SPACER-VERTICAL BALL SCREW STOP
2	6759F	BLOCK, FLANGE-SERVO MOTOR
3	MF-33	SOCKET HEAD CAP SCREW 3/8-16 X 1 1/2"
4	MF-187B	NYLOCK NUTS 3/8-16
5	10023D	VERTICAL BEARING SUPPORT BRACKET
6	6037C	SPRING, BELLEVILLE VERTICAL BALLSCREW STOP

**Z-Axis Assembly Installation onto Spindle**

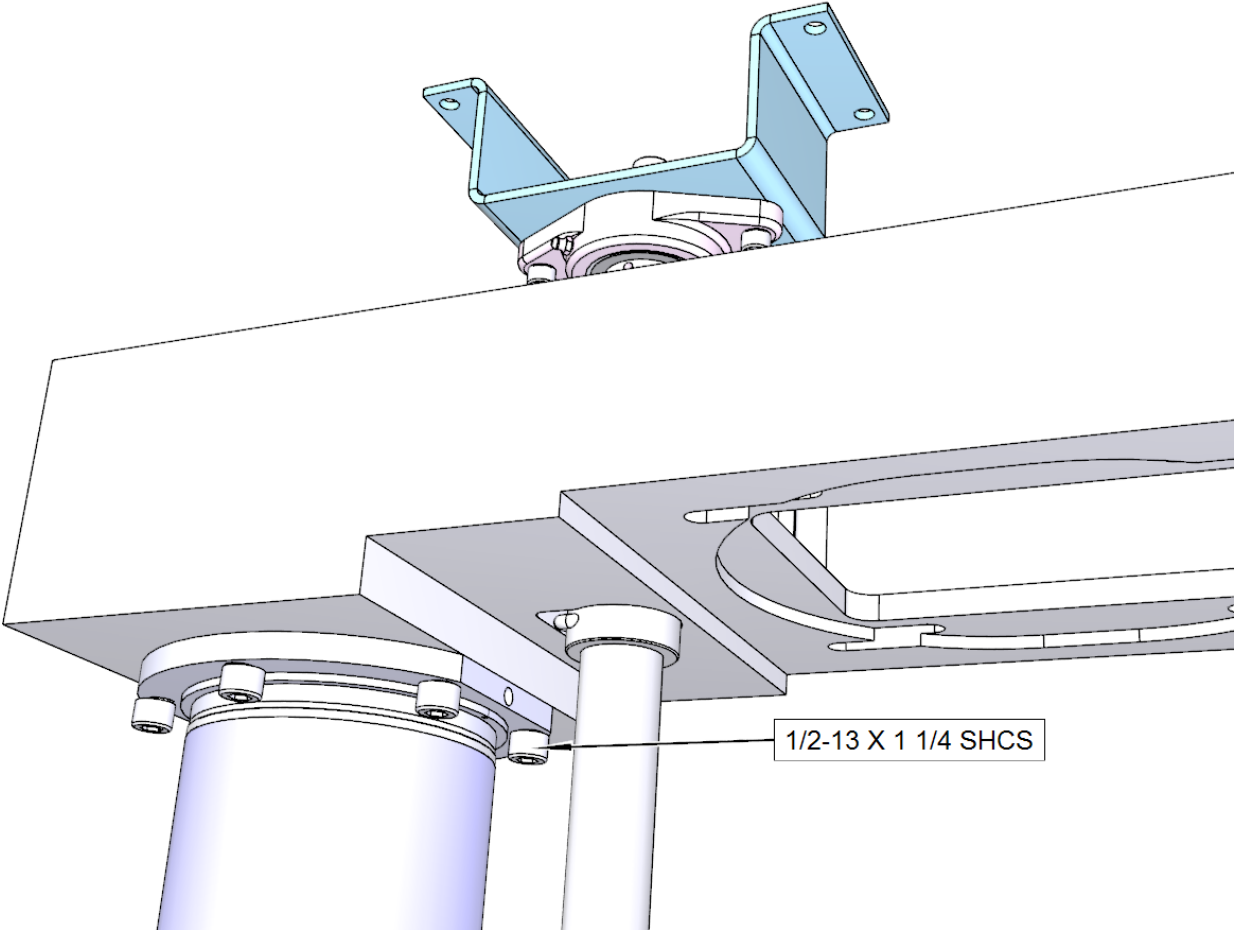

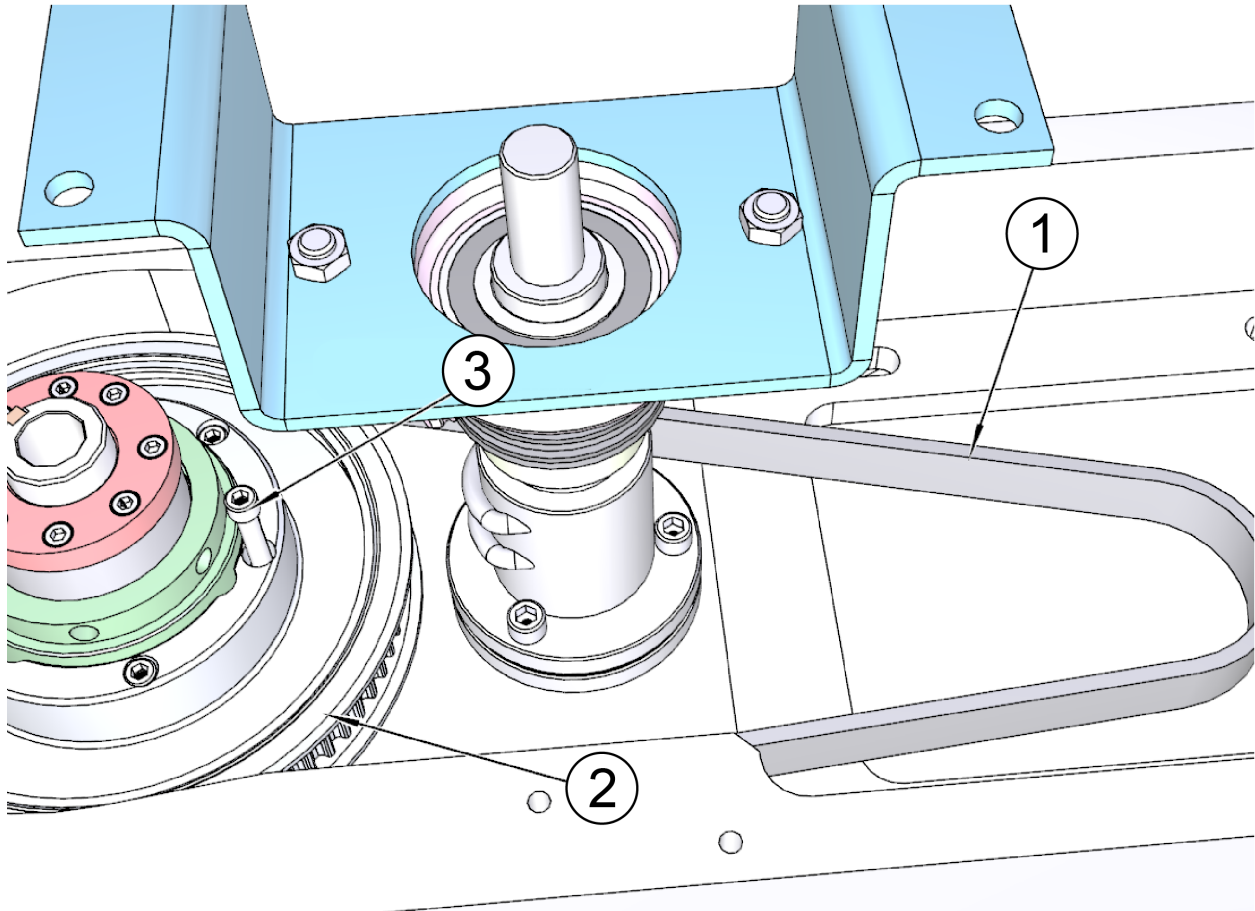
**Motor Housing Components****Internal Components**

ITEM	PART #	DESCRIPTION
1	9215N	BELT, SPINDLE DRIVE
2	9215M	SPROCKET, DRIVEN 60 TOOTH SPINDLE DRIVE
3	MF-18	SOCKET HEAD CAP SCREW 1/4-20 X 1 3/4"

### Motor and Adjusting Components

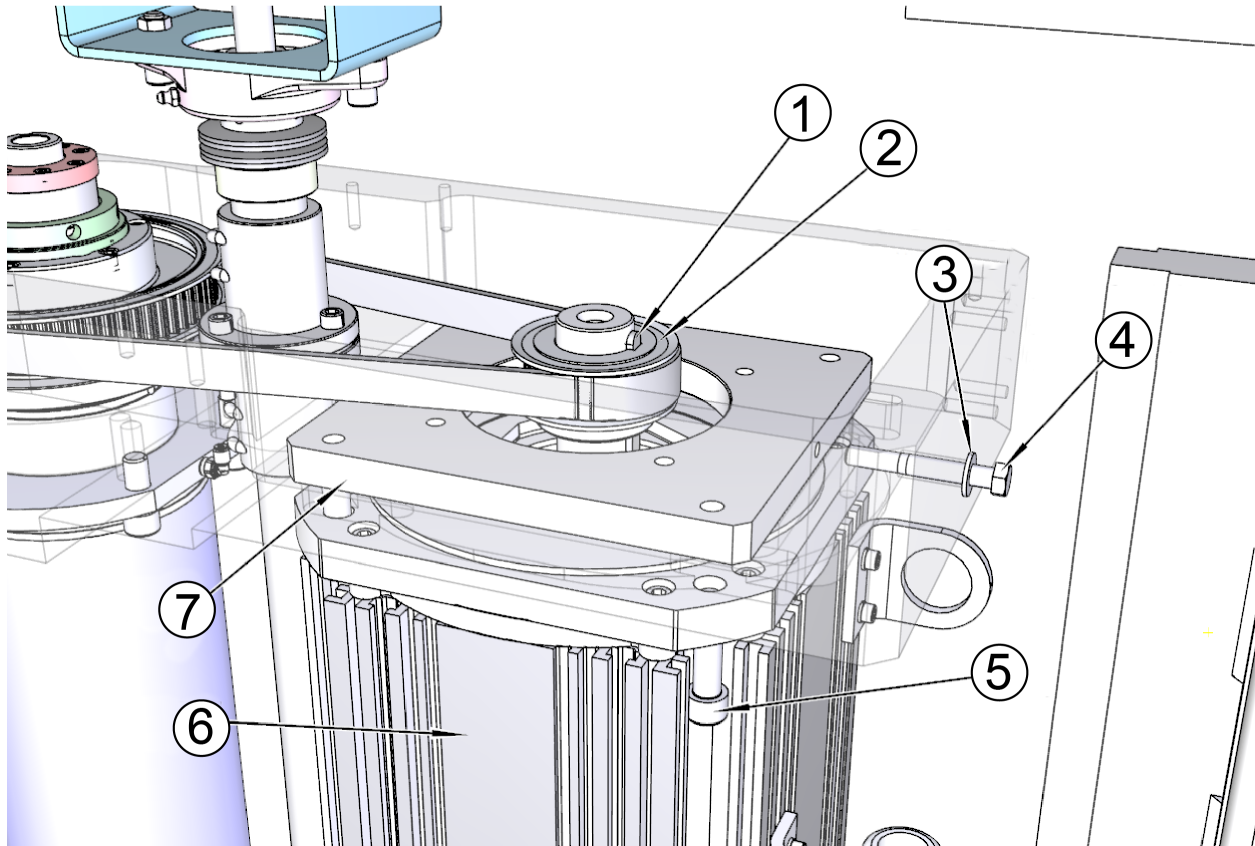

ITEM	PART #	DESCRIPTION
1	9215G	MOTOR, SPINDLE - BISS ENCODER
2	9215B	SPROCKET,DRIVE SPINDLE DRIVE
3	100-28-18	WASHER, FLAT
4	MF-147	HEX BOLT 3/8-16 X 2 1/4"
5	MF-45	SOCKET HEAD CAP SCREW 1/2-13 X 2"
6	9215G	MOTOR, SPINDLE - BISS ENCODER
7	9216A	MOTOR MOUNT PLATE -SPINDLE DRIVE MOTOR

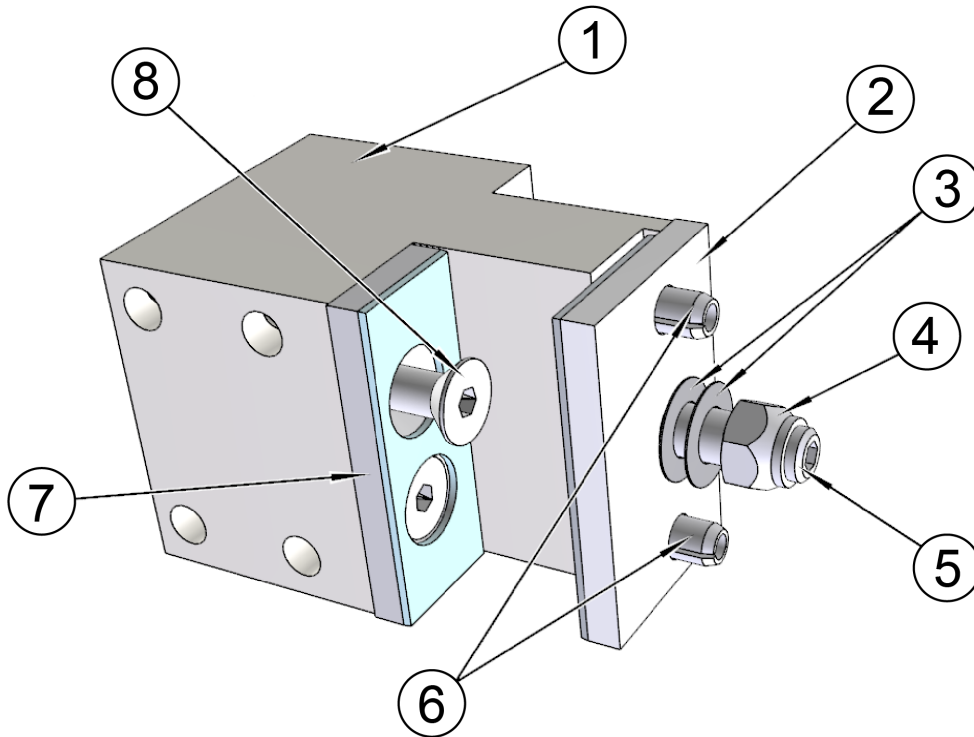

**Guide Block Assembly**

ITEM	PART #	DESCRIPTION
1	6760J	BRACKET,MOUNTING-LINEAR BEARING
2	6760L	BEARING, OUTER-LINEAR GUIDE
3	6760F	SPRING,BELLEVILLE-LINEAR BEARING
4	MF-187B	NYLOCK NUTS 3/8-16
5		3/8-16 X 2 SOCKET HEAD SET SCREW FLAT POINT
6	MF-228	ROLL PIN 5/16 X 1 1/2"
7	6760K	BEARING, INNER-LINEAR GUIDE
8	MF-85	SOCKET FLAT HEAD SCREW 3/8-16 X 3/4"

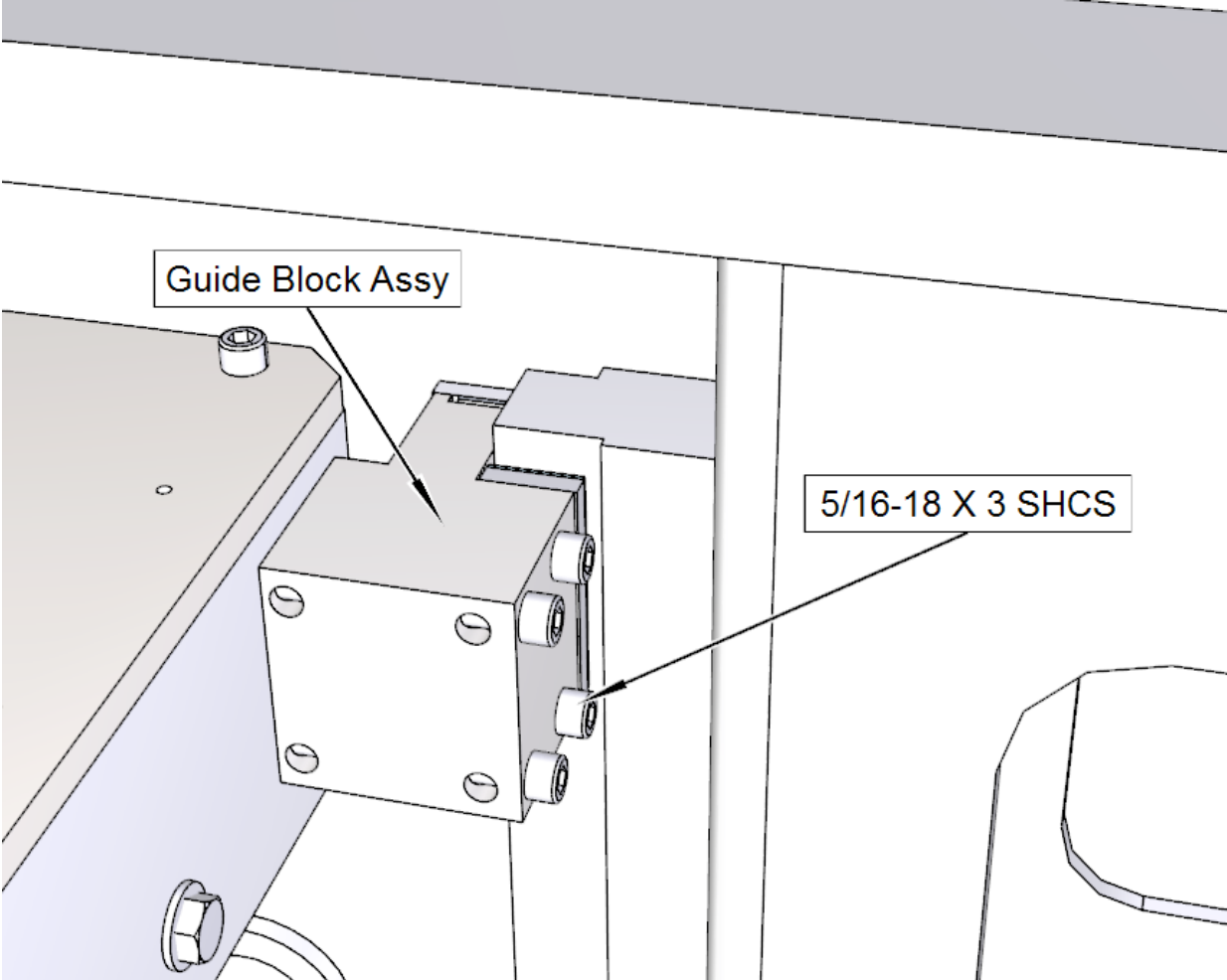

## Drawbar Clamp

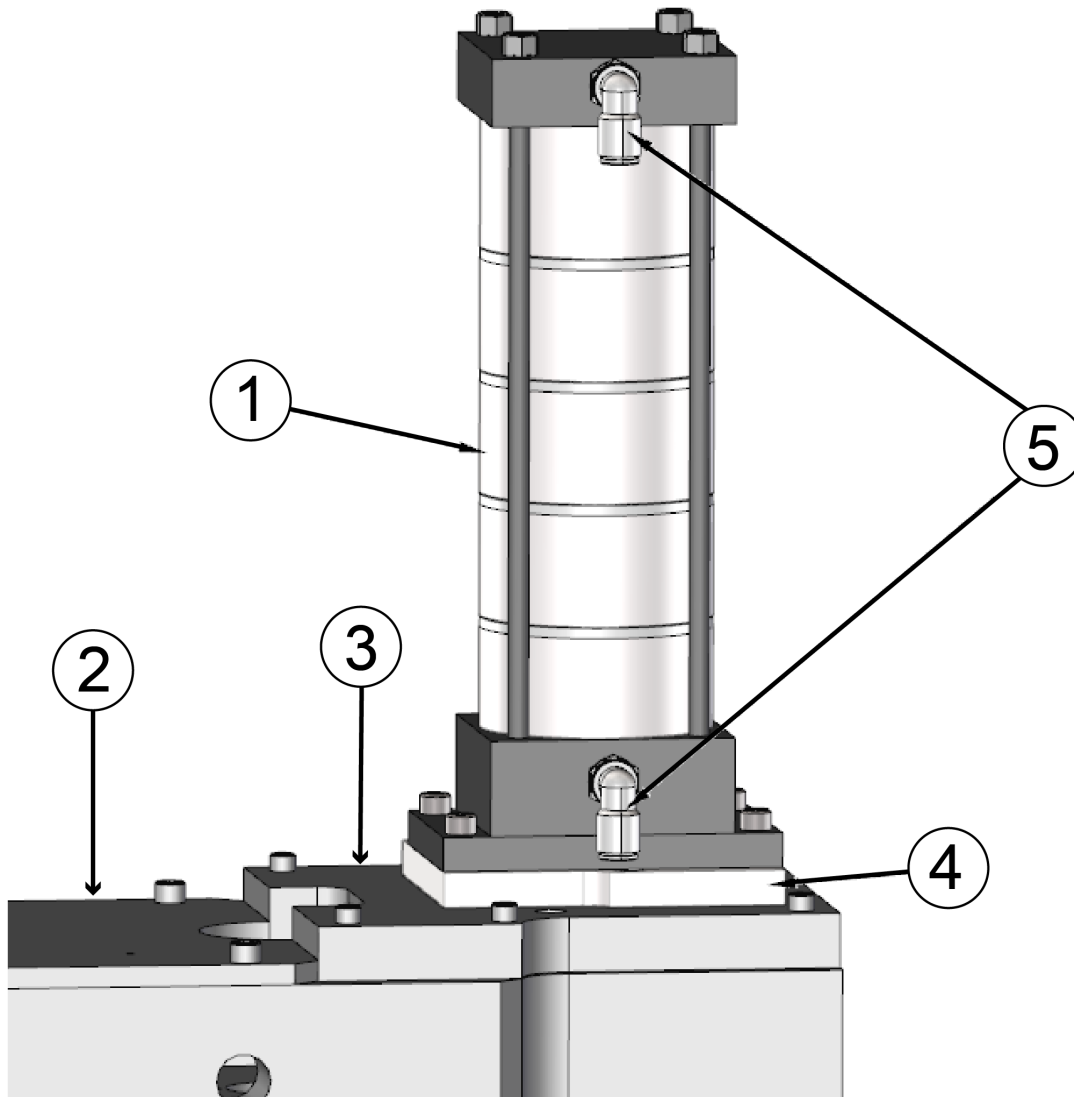

ITEM	PART #	DESCRIPTION
1	10042B	CYLINDER, DRAWBAR RELEASE
2	9216D	COVER, REAR-UPPER HOUSING
3	9216H	COVER, FRONT UPPER HOUSING
4	10042C	SPACER, DRAWBAR RELEASE CYLINDER
5		3/8 X 1/2 MPT 90 DEGREE FITTING

### Cable Cylinder Components

#### Lower Section

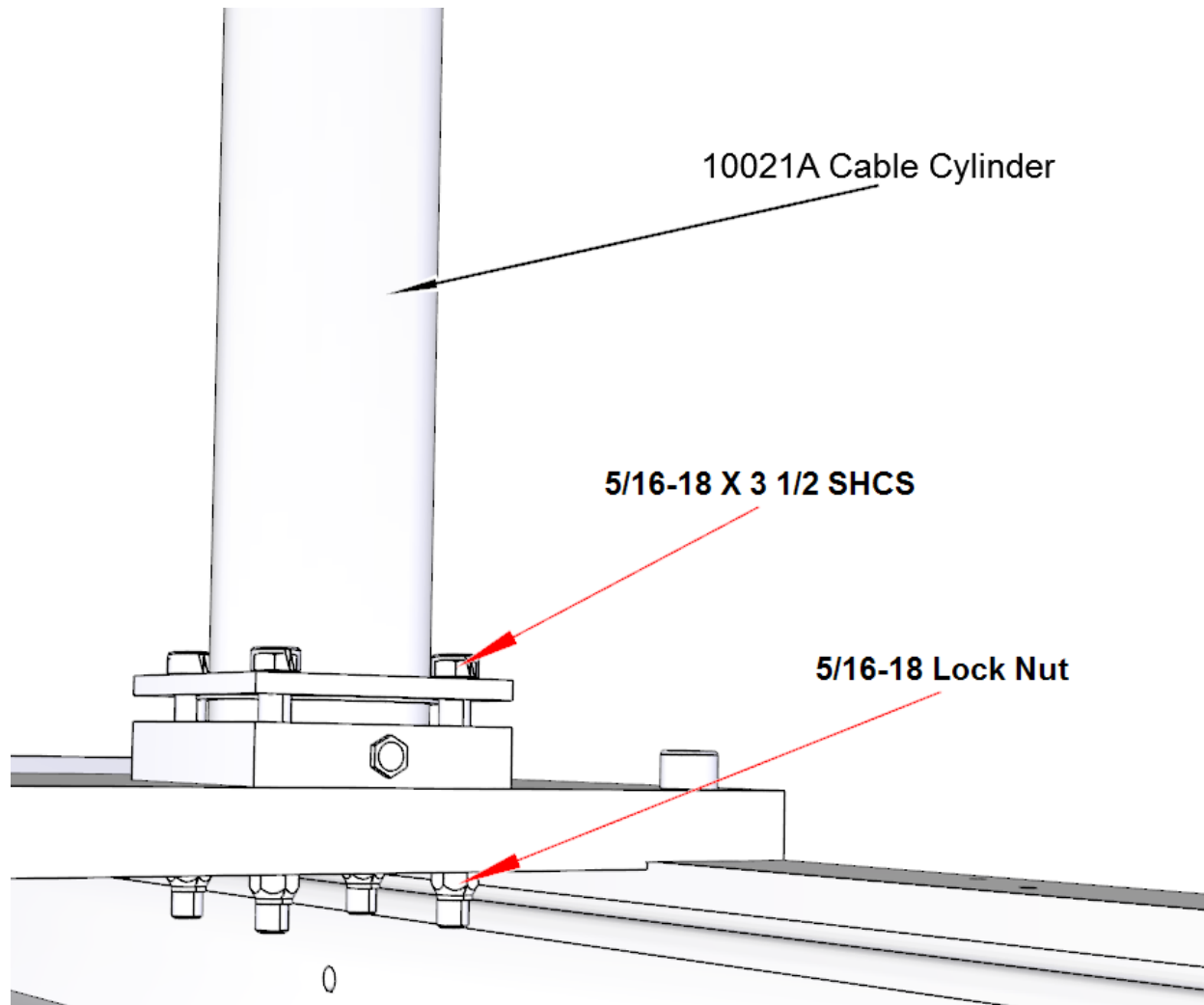

**Top Plate Components**

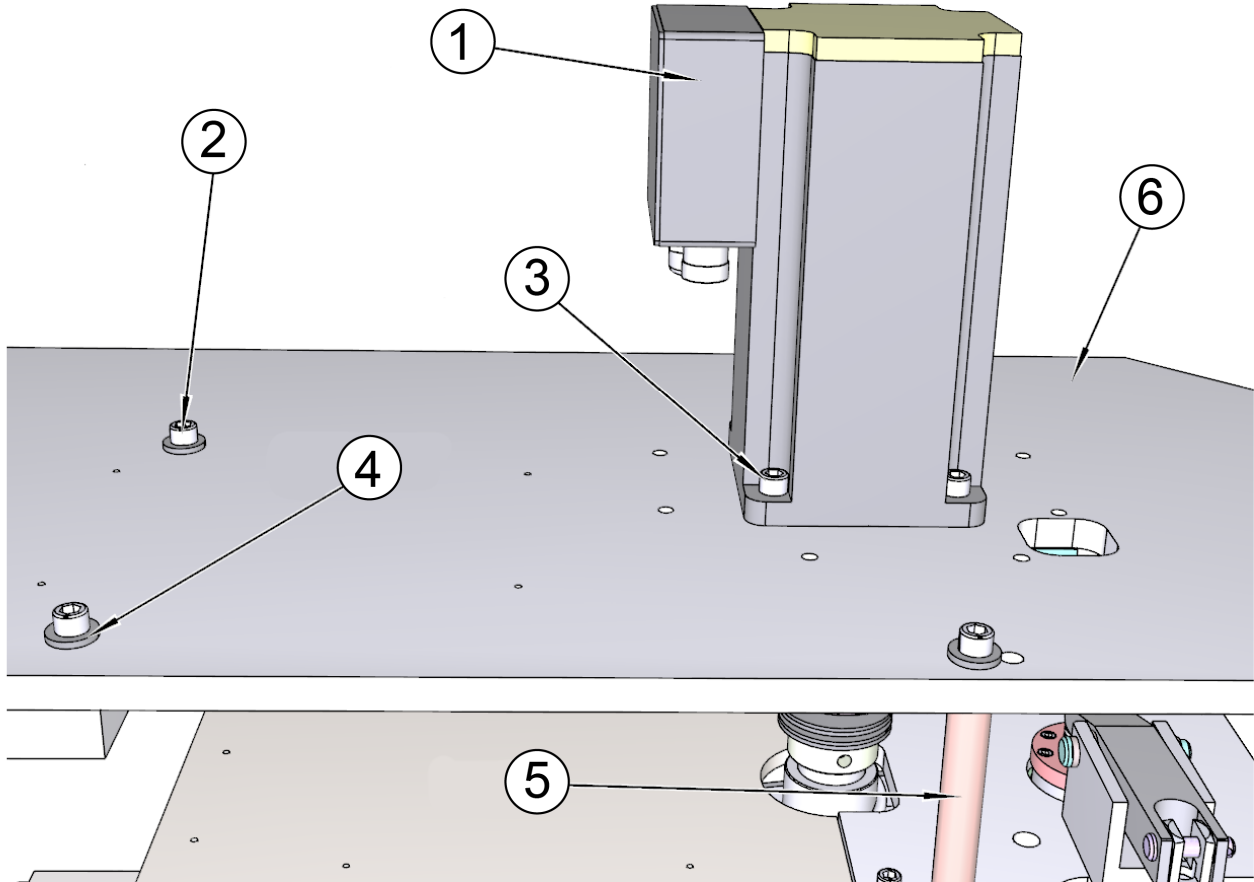

ITEM	PART #	DESCRIPTION
1	6481G	MOTOR, AC SERVO
2	MF-33	SOCKET HEAD CAP SCREW 3/8-16 X 1 1/2"
3	MF-31	SOCKET HEAD CAP SCREW 3/8-16 X 1"
4	100-28-18	WASHER, FLAT
5	10014F	SUPPORT BAR, TOP PLATE
6	9208	TOP PLATE

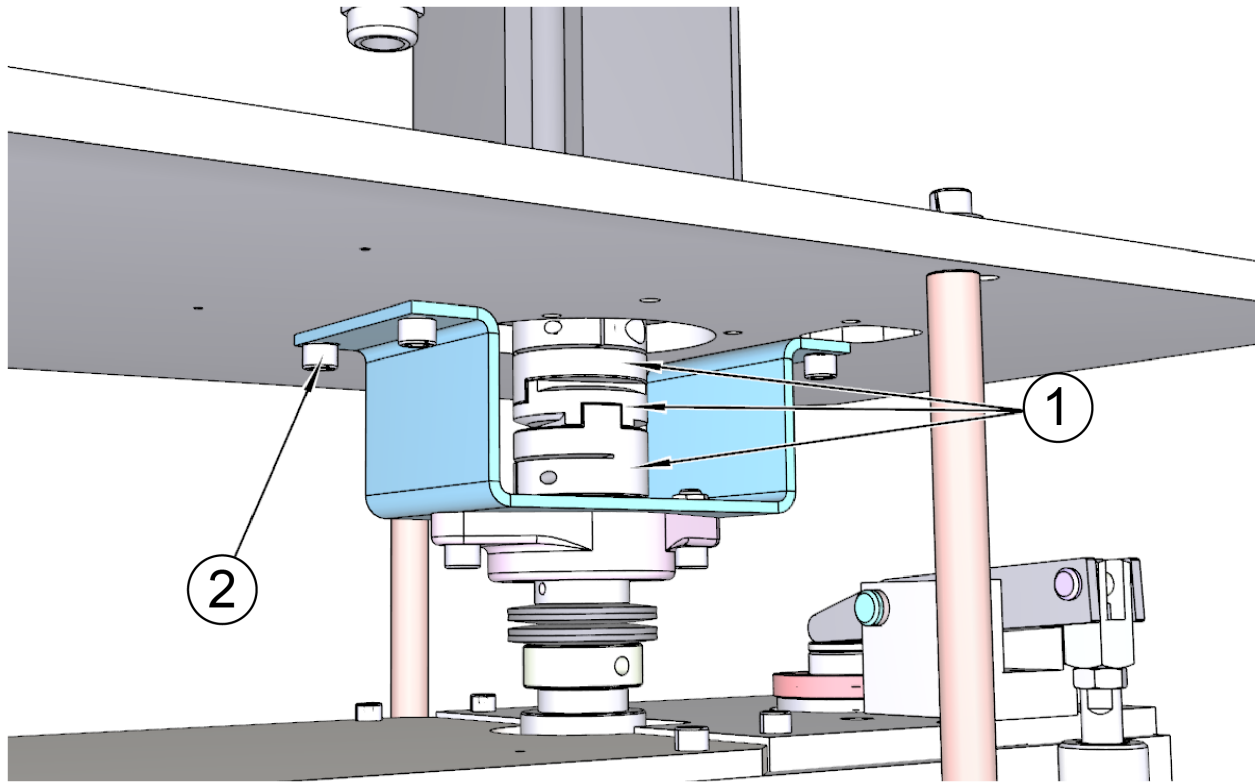
**Z-Axis Motor Connection**

ITEM	PART #	DESCRIPTION
1	9001P	COUPLING ASSEMBLY
2	MF-30	SOCKET HEAD CAP SCREW 3/8-16 X 3/4"

## Upper Section

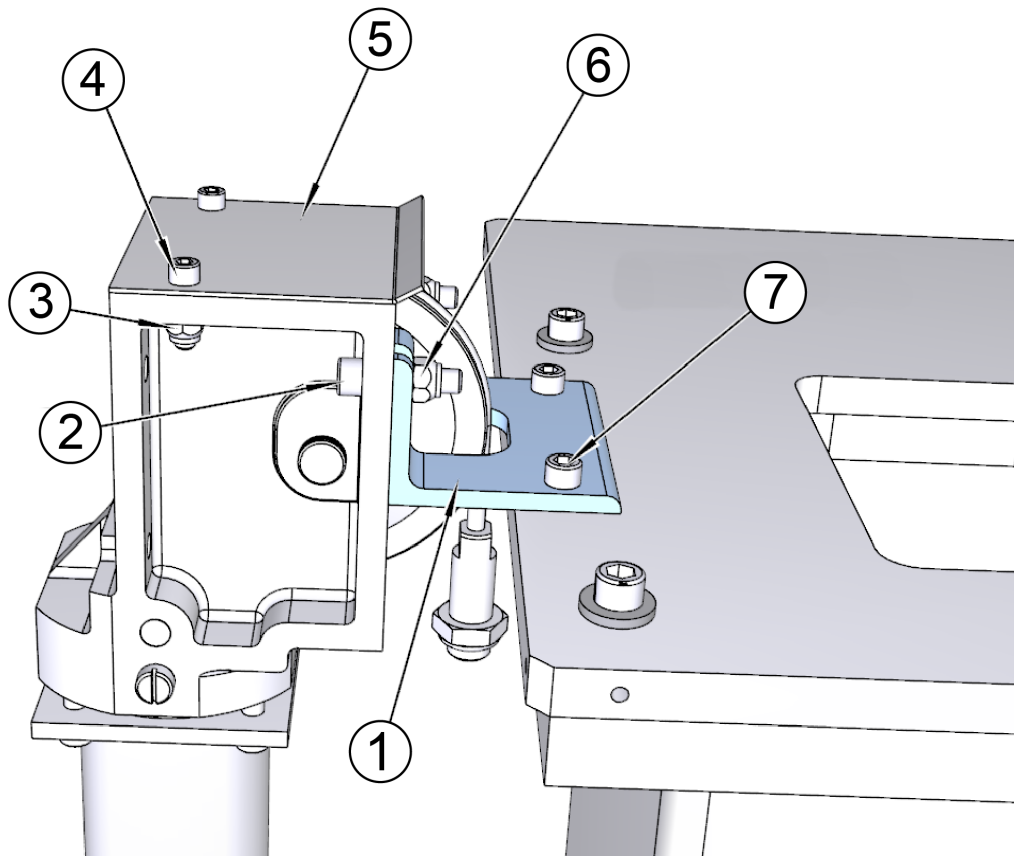

ITEM	PART #	DESCRIPTION
1	9217B	SUPPORT BRACKET, UPPER CABLE CYLINDER
2	MF-24	SOCKET HEAD CAP SCREW 5/16-18 X 1 1/4"
3	MF-186A	NYLOCK NUTS 1/4-20
4		1/4-20 X 7/8 SOCKET HEAD CAP SCREW
5	9217A	GUIDE/COVER, COUNTERBALANCE CYLINDER
6	MF-187	NYLOCK NUTS 5/16-18 NC
7	MF-21	SOCKET HEAD CAP SCREW 5/16-18 X 5/8"

## Counterbalance Cylinder Pop Off Valve Assembly Parts

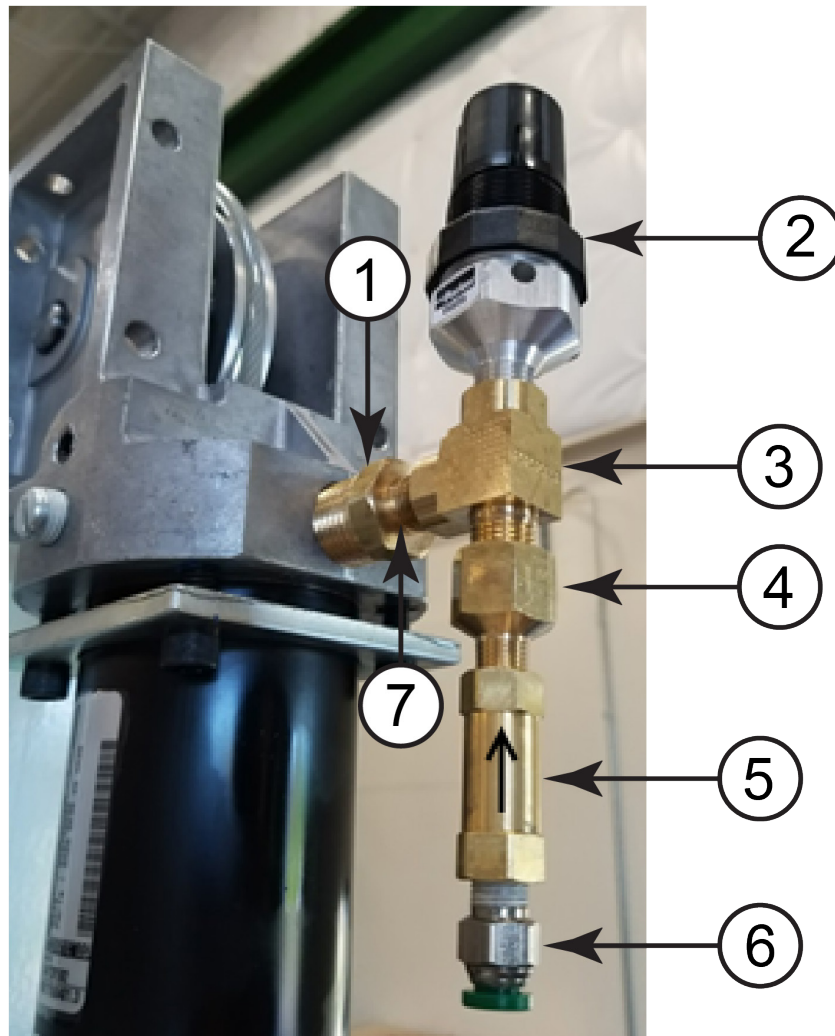

Pop Off Valve Assembly Parts		
Item #	Part #	Description
1	514-4-18C	FITTING, BRASS 3/8 TO 1/4
2	6449	VALVE,RELIEF-COUNTERWEIGHT
3	502-11-17W	TEE, 1/4 FPT X 1/4 MPT
4	502-11-17L	ADAPTER, 1/4 TO 1/8" MALE PIPE FITTING
5	517-7-58	CHECK VALVE
6	514-4-17W	FITTING, 1/4 X 1/8 MPT
7	502-11-17K	NIPPLE, CLOSE, 1/4 MPT X 1



## **Top Plate Pulley Assembly**

**Assembly Image and Parts List are unavailable at this time.**

**Please visit the service tab of our web page at Send a Service Request [www.rottlermfg.com](http://www.rottlermfg.com) or contact the Rottler Factory Service at [service@rottlermfg.com](mailto:service@rottlermfg.com) for assistance and your service request.**

**You may also call Rottler at 1-800-452-0534 or 1-253-872-7050**

**Please ensure you have the Machine Model and Serial Number available when contacting Rottler for Service**

## Spindle Base Front Covers

### Brackets

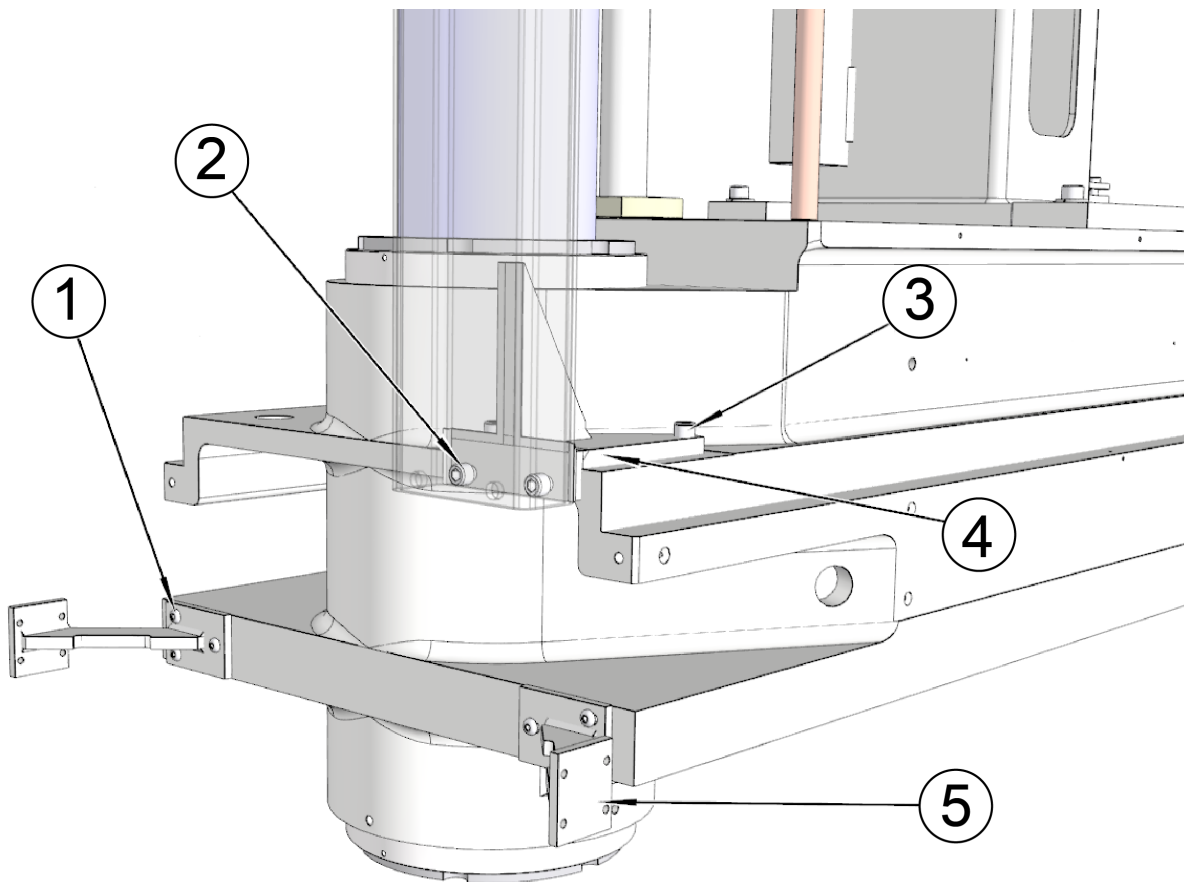

ITEM	PART #	DESCRIPTION
1	MF-14	SOCKET HEAD CAP SCREW 1/4-20 X 3/4"
2	MF-32	SOCKET HEAD CAP SCREW 3/8-16 X 1 1/4"
3	MF-31	SOCKET HEAD CAP SCREW 3/8-16 X 1"
4	10013K	PENDANT SUPPORT
5	9222A	MOUNT BRACKET,CHIP SHIELD

## Covers and Lights

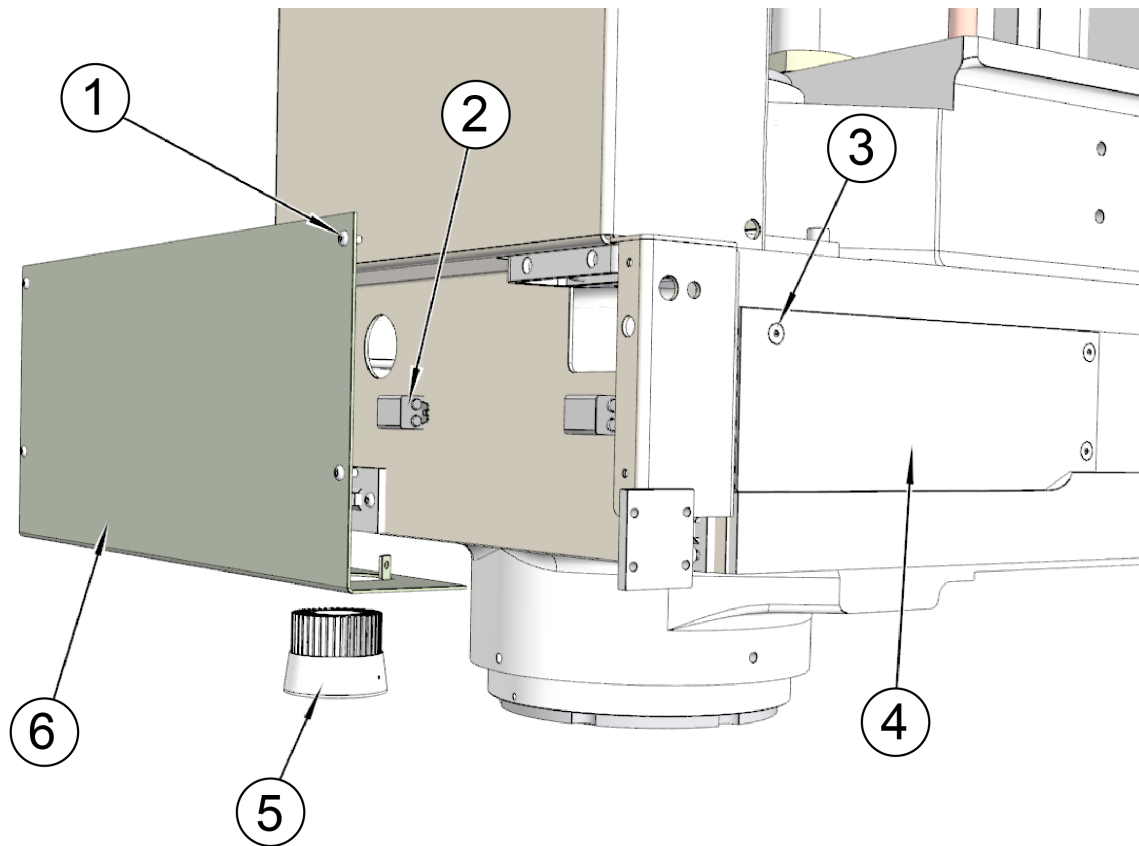

ITEM	PART #	DESCRIPTION
1	MF-86A	SOCKET BUTTON HEAD SCREW 8-32 X 3/8"
2	6457N	LIGHT, CHIP SHIELD L.E.D
3	MF-82B	SOCKET FLAT HEAD SCREW 1/4-20 X 3/8"
4	10013F	RIGHT SIDE COVER, LOWER-SPINDLE BASE
5	6457N	LIGHT, CHIP SHIELD L.E.D
6	9222C	LIGHT MOUNT-COVER, SPINDLE BASE

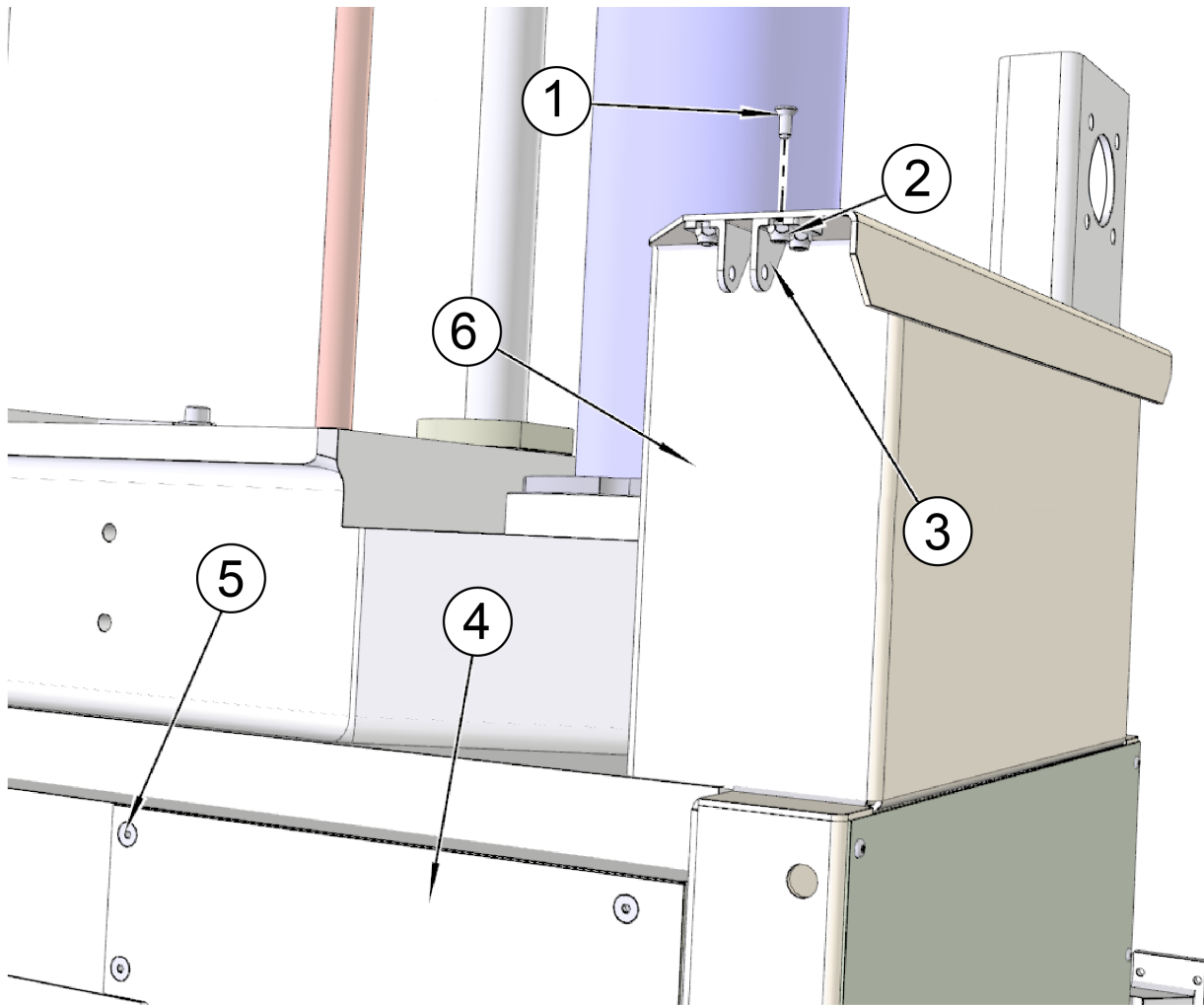

ITEM	PART #	DESCRIPTION
1	MF-79	SOCKET FLAT HEAD SCREW 10-24 X 1/2"
2	MF-186B	NYLOCK NUTS 10-24
3	11032C	BRACKET KIT ,AIR CYLINDER-CHIP SHIELD
4	10013E	LEFT SIDE COVER, LOWER-SPINDLE BASE
5	MF-82B	SOCKET FLAT HEAD SCREW 1/4-20 X 3/8"
6	9222B	FRONT PLATE, SPINDLE BASE

### Column Lower Section Components

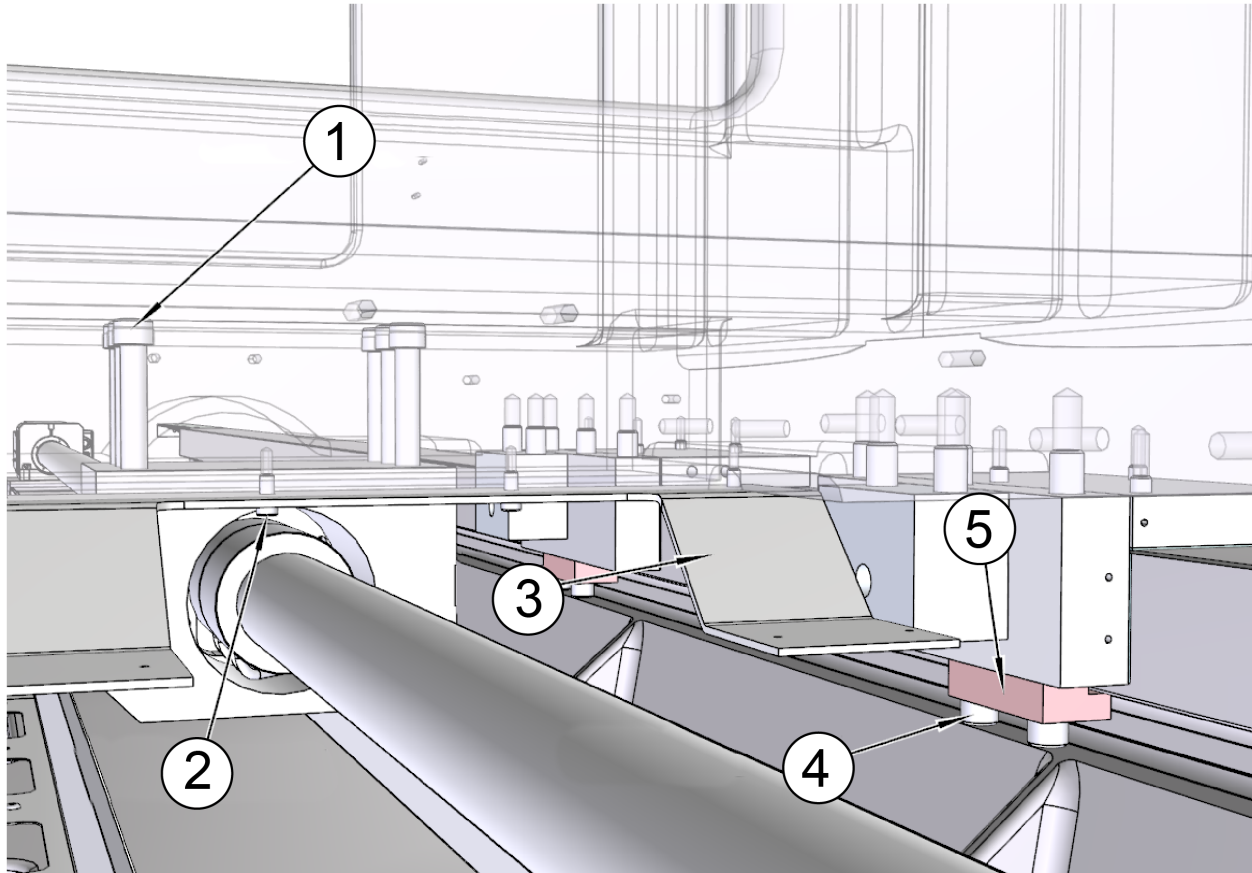

ITEM	PART #	DESCRIPTION
1		5/8-11 X 4 SOCKET HEAD CAP SCREW
2	MF-12	SOCKET HEAD CAP SCREW 1/4-20 X 1/2"
3	10040	SUPPORT, CABLE CARRIER
4	MF-44	SOCKET HEAD CAP SCREW 1/2-13 X 1 1/2"
5	6190M	STOP BAR, LIFT

## Spindle Base Gib Assemblies

### Right Side

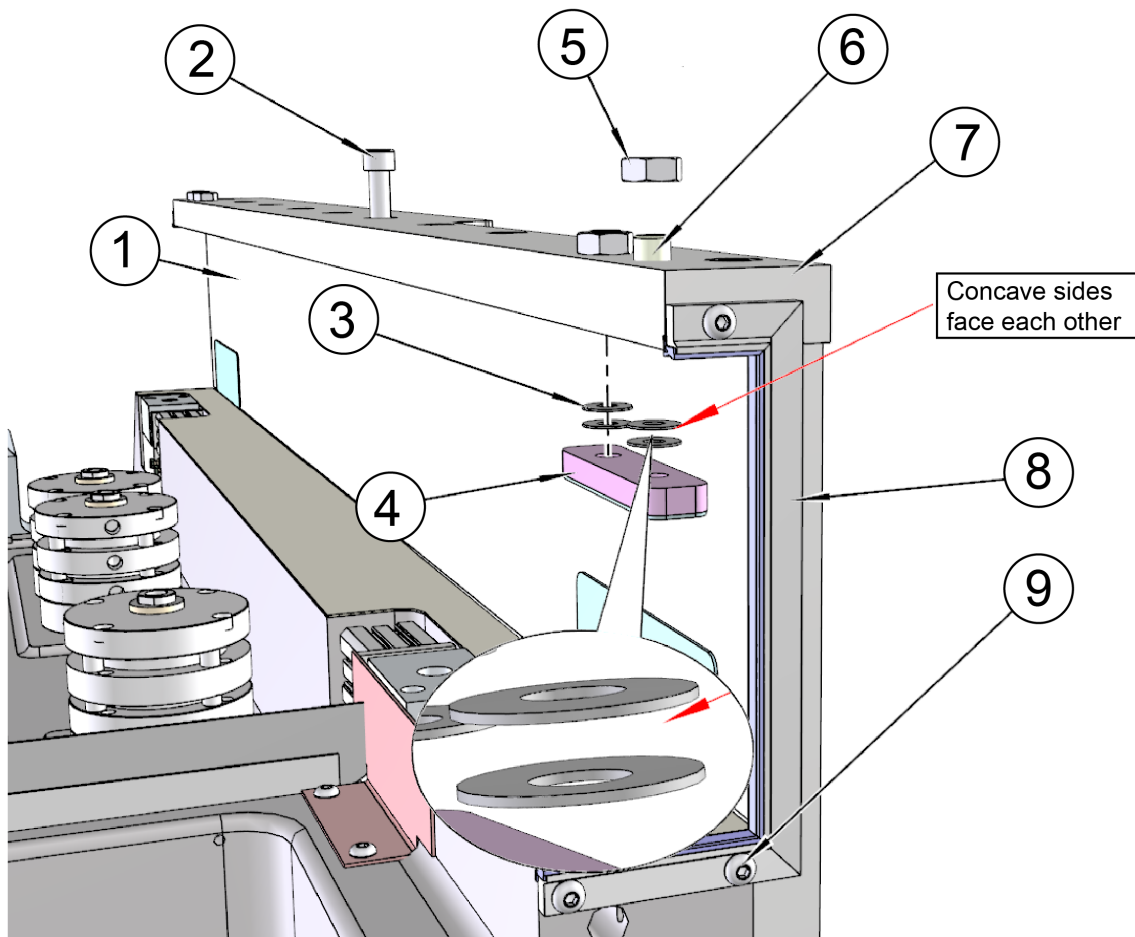

ITEM	PART #	DESCRIPTION
1	10003A	BAR, FIXED GIB
2	MF-43	SOCKET HEAD CAP SCREW 1/2-13 X 1 1/4"
3	9024E	SPRING,BELLEVILLE
4	9024A	GIB ASSEMBLY
5	MF-172	HEX JAM NUTS 1/2-20 NF
6	9202D	SCREW,GIB ADJUSTING
7	10003T	GIB BAR RIGHT SIDE
8	9224	WAY WIPER
9	MF-90	SOCKET BUTTON HEAD SCREW 1/4-20 X 1/2"

## Left Side

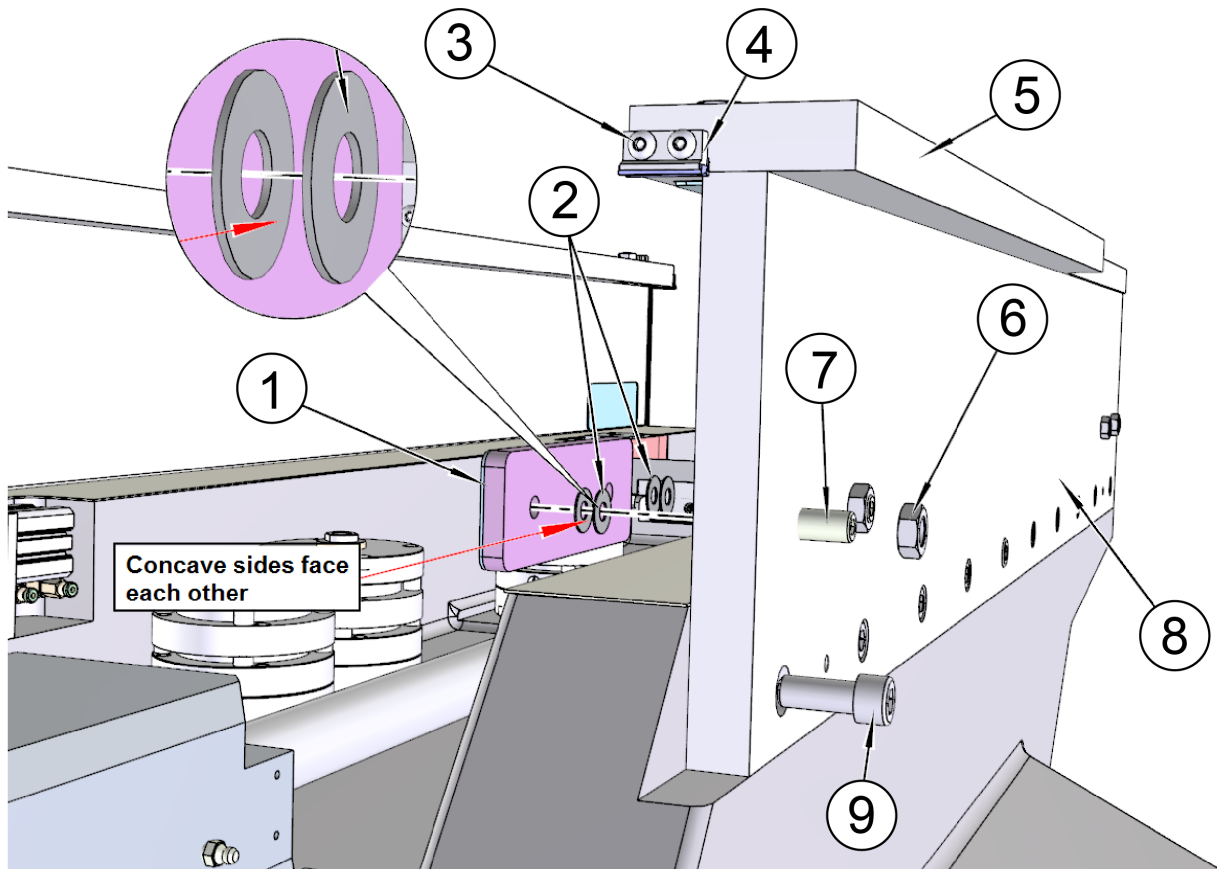

ITEM	PART #	DESCRIPTION
1	10003F	GIB, SPRING
2	9024E	SPRING,BELLEVILLE
3	MF-90	SOCKET BUTTON HEAD SCREW 1/4-20 X 1/2"
4	10003P	WAY WIPER
5	10003B	GIB BAR LEFT SIDE
6		1/2-20 JAM NUT
7	9202D	SCREW,GIB ADJUSTING
8	10003E	GIB BAR, COLUMN
9	MF-43	SOCKET HEAD CAP SCREW 1/2-13 X 1 1/4"

### Spindle Base Wire Box

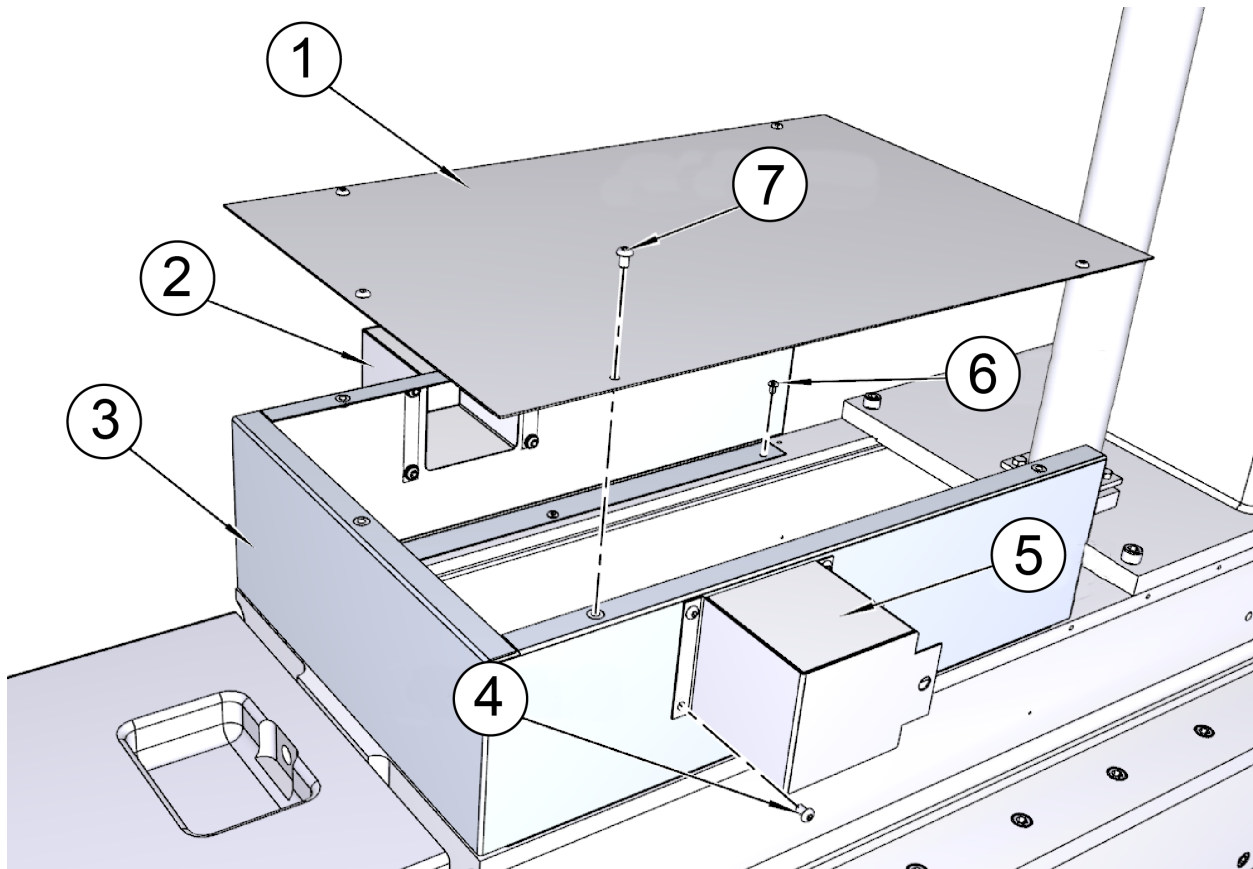

ITEM	PART #	DESCRIPTION
1	10015K	LID, COVER BOX
2	10015E	COVER, CABLE CARRIER MOUNT
3	10015J	COVER BOX
4	MF-248	SOCKET BUTTON HEAD SCREW 1/4-20 X 3/8"
5	10015D	BOX, CABLE CARRIER MOUNT
6	MF-248	SOCKET BUTTON HEAD SCREW 1/4-20 X 3/8"
7	MF-248	SOCKET BUTTON HEAD SCREW 1/4-20 X 3/8"



### Spindle Motor Wire Track

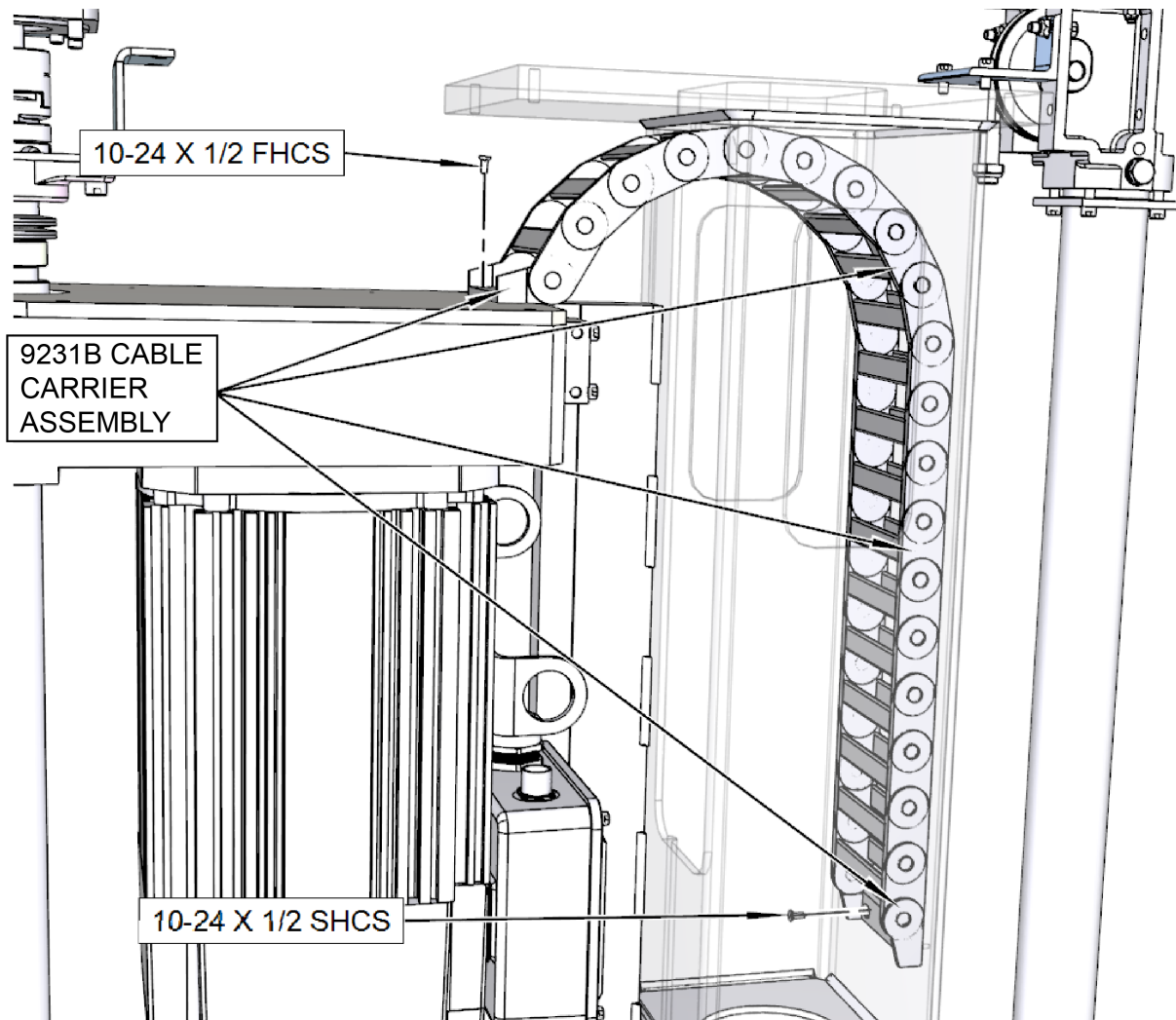

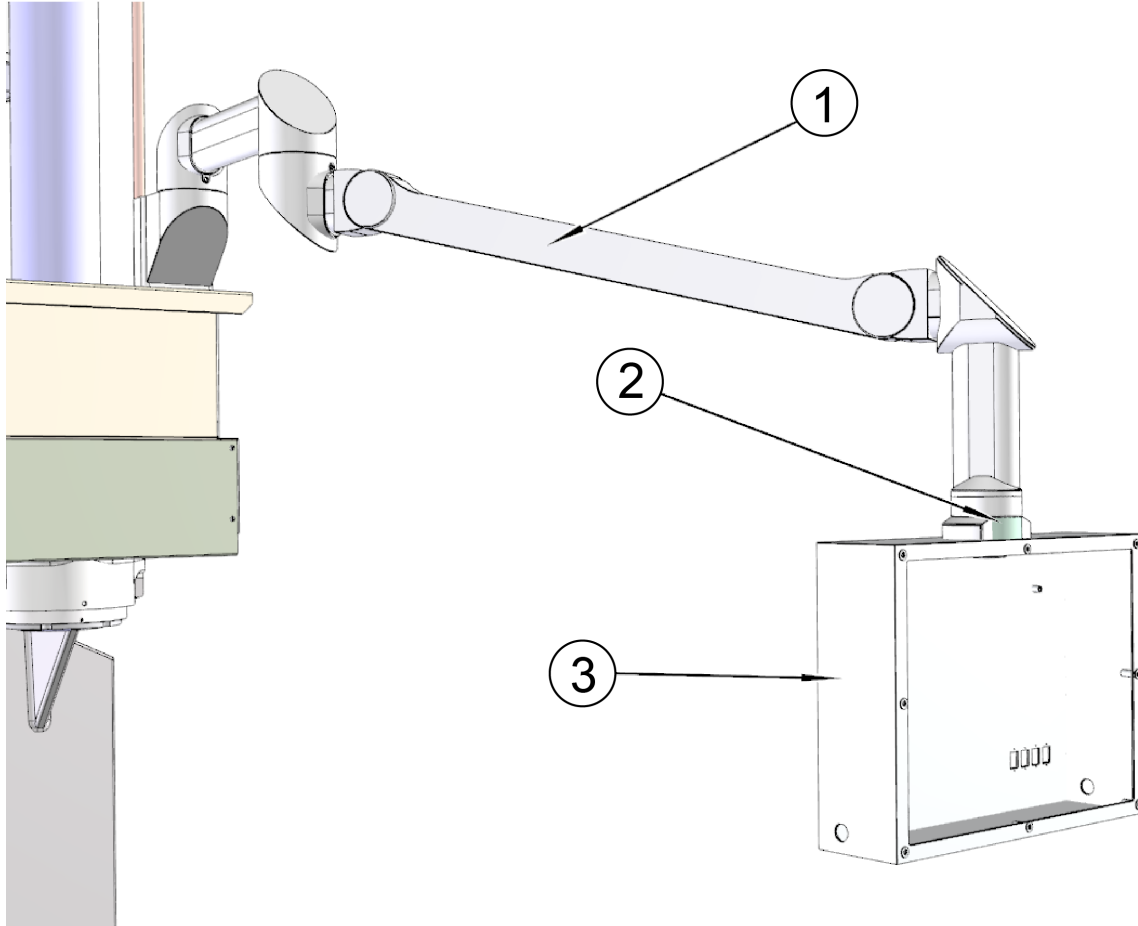
**Pendent and Control Housing**

ITEM	PART #	DESCRIPTION
1	10032	PENDANT SUPPORT ARM ASSEMBLY
2	6196B	SWIVEL HOUSING, PENDANT
3	6198Q	ENCLOSURE, PENDANT CONTROL

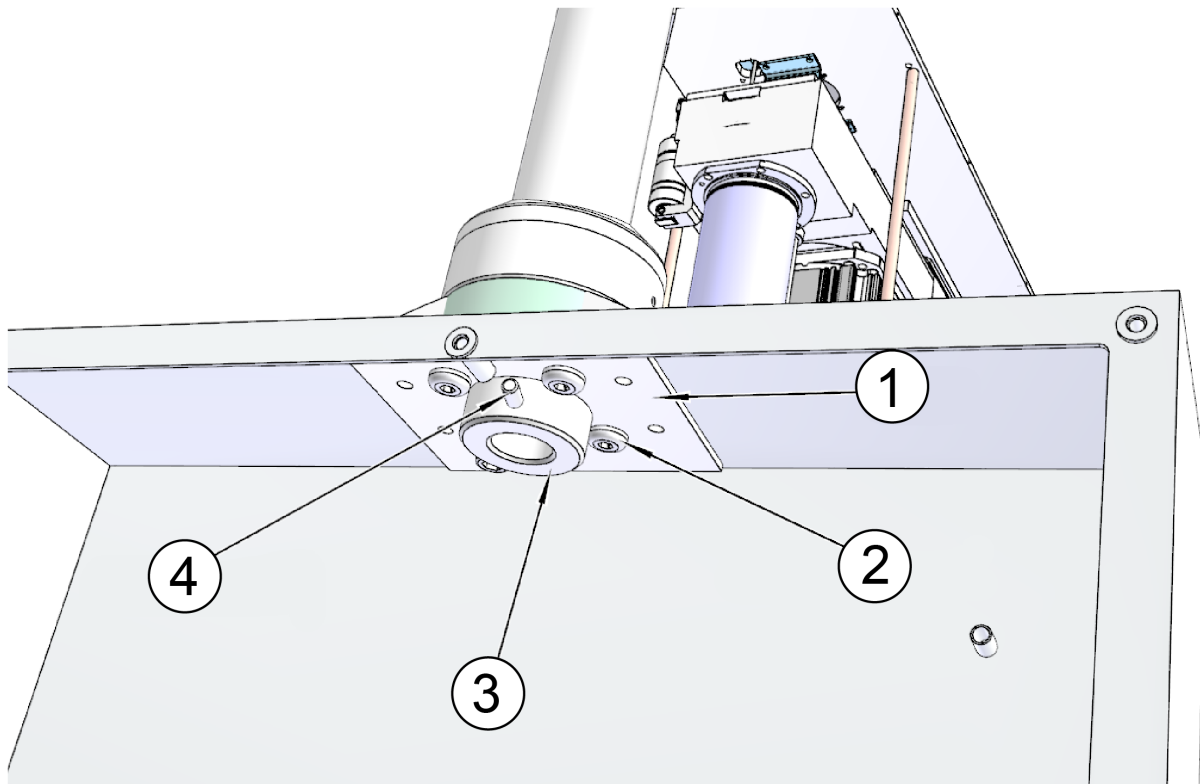

ITEM	PART #	DESCRIPTION
1	6385E	SUPPORT PLATE-UPPER PENDANT
2	MF-96	SOCKET BUTTON HEAD SCREW 3/8-16 X 3/4"
3	6197B	SWIVEL, PENDANT SUPPORT
4	MF-204	DOWEL PIN 1/4 X 1"

## Control Housing Outside Components

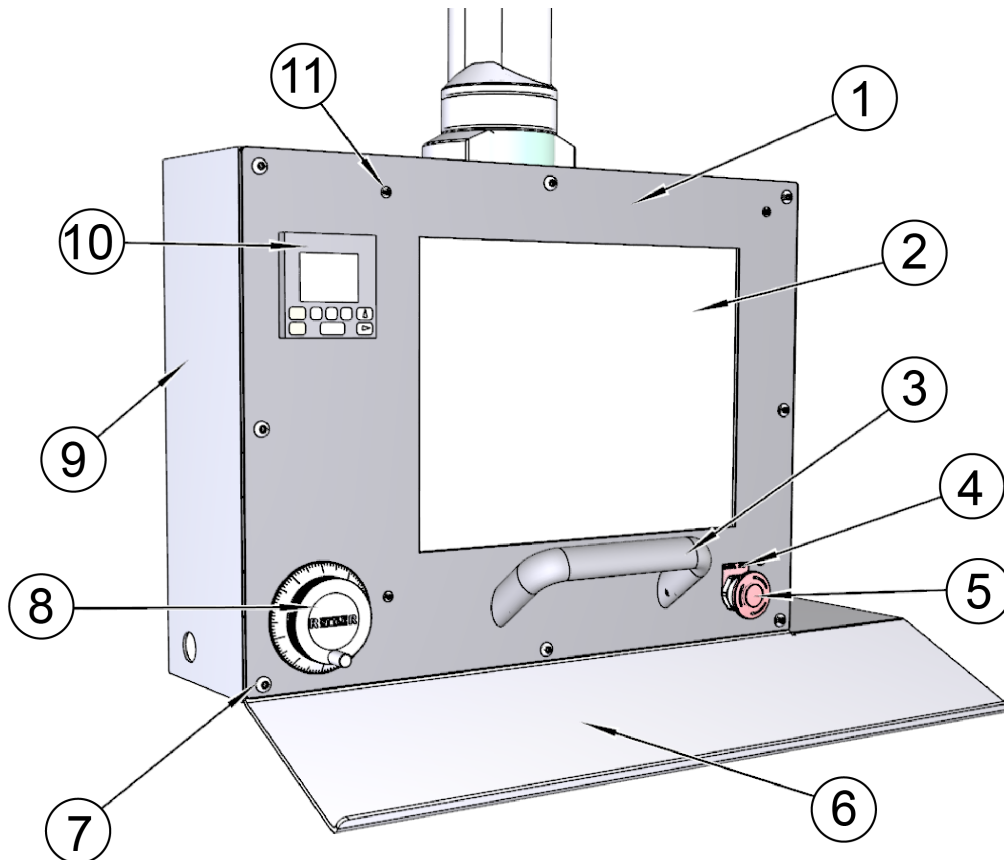

ITEM	PART #	DESCRIPTION
1	9031	ADHESIVE LAYOVER, PENDANT FACEPLATE
2	650-1-28X	TOUCH PANEL-15" WITH USB PORT
3	650-1-2G	HANDLE, TOUCH PANEL
4	6389B	PLATE, LEGEND-EMERGENCY STOP PUSHBUTTON
5	6389D	PUSHBUTTON, EMERGENCY STOP
6	6198S	FACEPLATE WITH KEYBOARD TRAY
7	MF-90	SOCKET BUTTON HEAD SCREW 1/4-20 X 1/2"
8	6428	WHEEL, HAND-MANUAL FEED
9	6198Q	ENCLOSURE, PENDANT CONTROL
10	502-12-7D	1 AXIS GAGING DISPLAY-DIGITAL RUNOUT GAGE
11	MF-88B	SOCKET BUTTON HEAD SCREW 6-32 X 3/8"

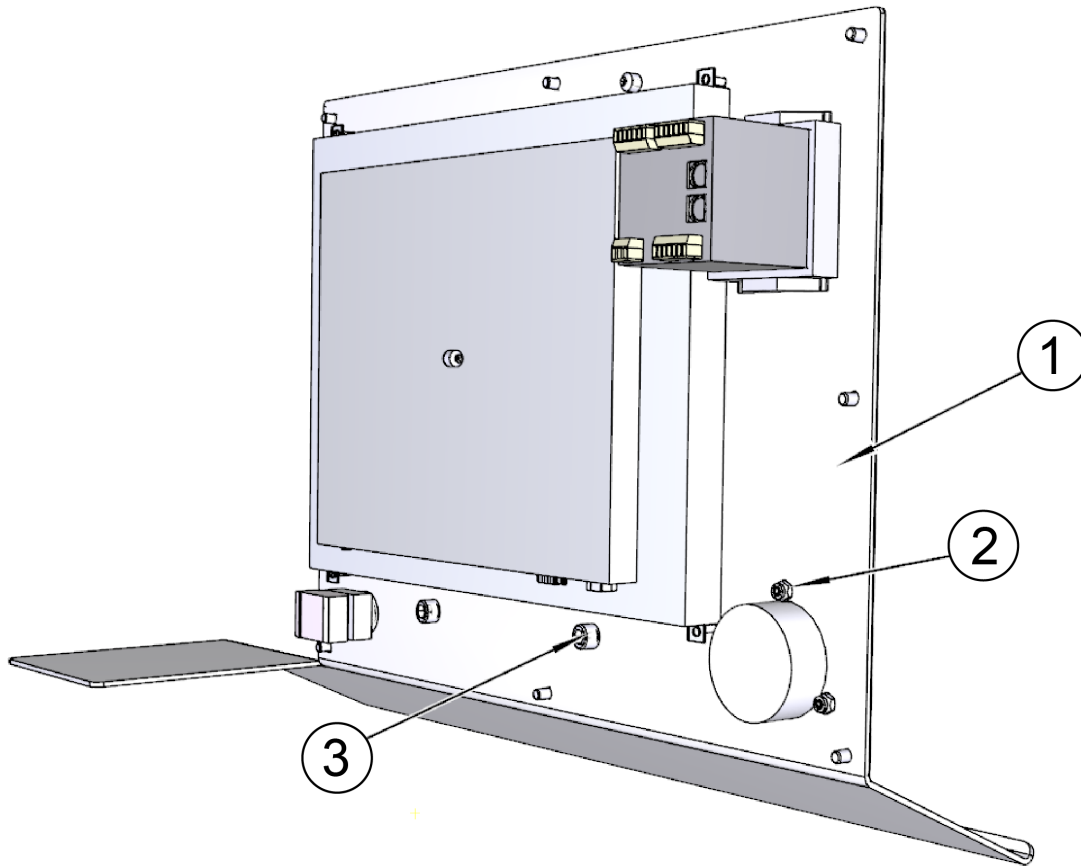
**Control Housing Inside Components**

ITEM	PART #	DESCRIPTION
1	6198S	FACEPLATE WITH KEYBOARD TRAY
2	MF-186D	NYLOCK NUT 8-32
3	MF-29	SOCKET HEAD CAP SCREW 3/8-16 X 1/2"

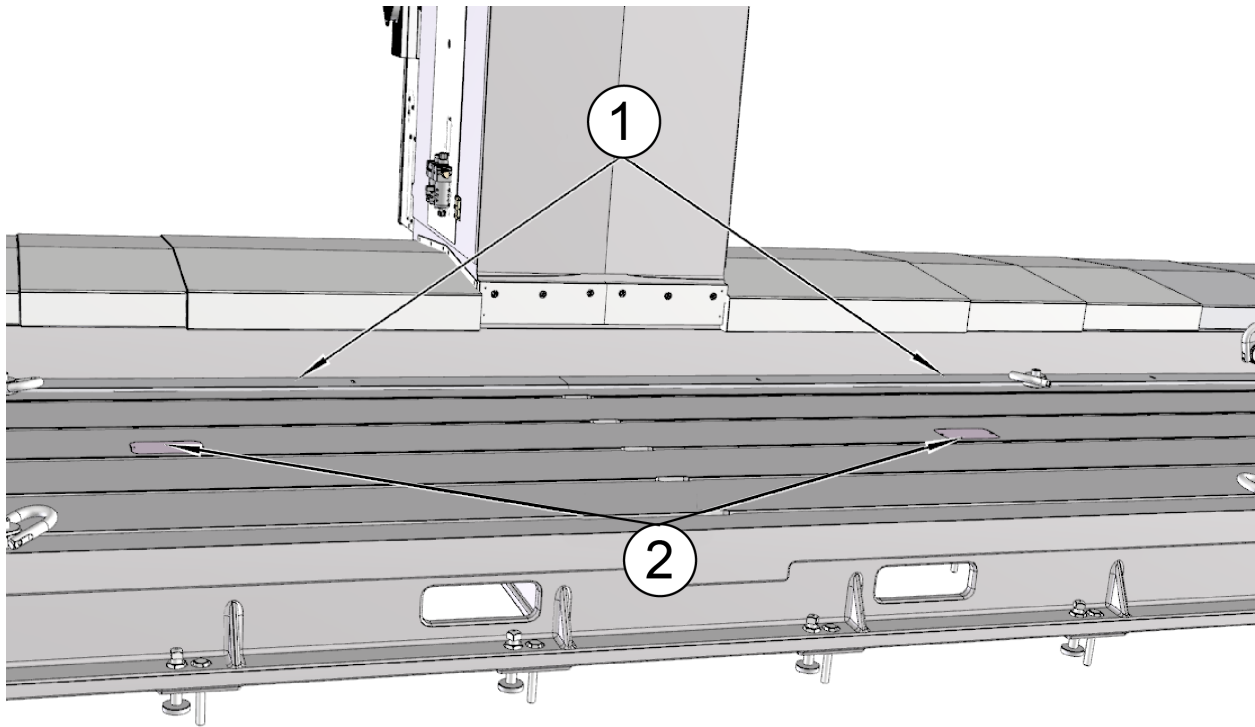
**Machine Base**

ITEM	PART #	DESCRIPTION
1	10011A	COVER BAR
2	10011C	COVER, ACCESS

### Spindle Base Covers

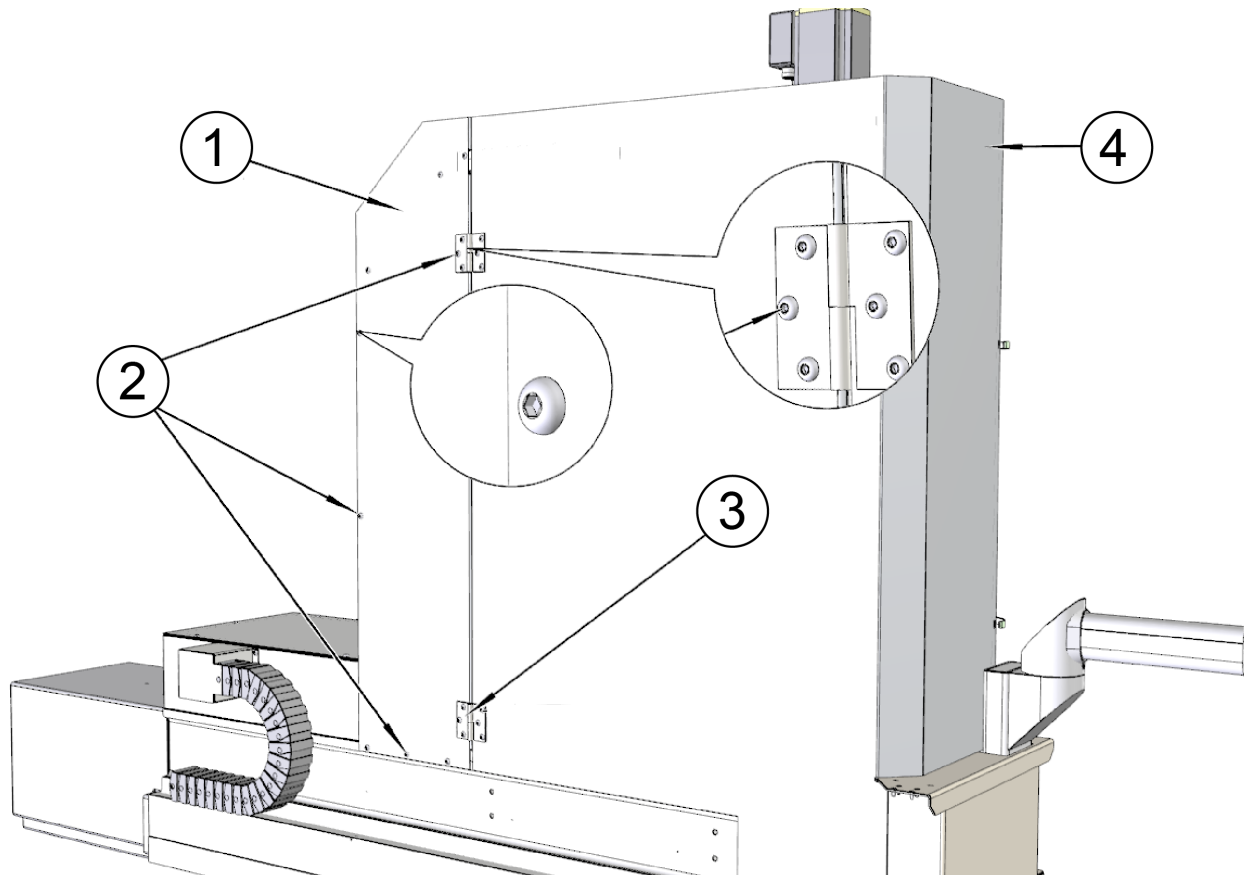

ITEM	PART #	DESCRIPTION
1	10016G	COVER, LEFT SIDE - REAR TOWER
2	MF-248	SOCKET BUTTON HEAD SCREW 1/4-20 X 3/8"
3	6320J	HINGE, SPINDLE COVER
4	10016H	COVER, DOOR - TOWER

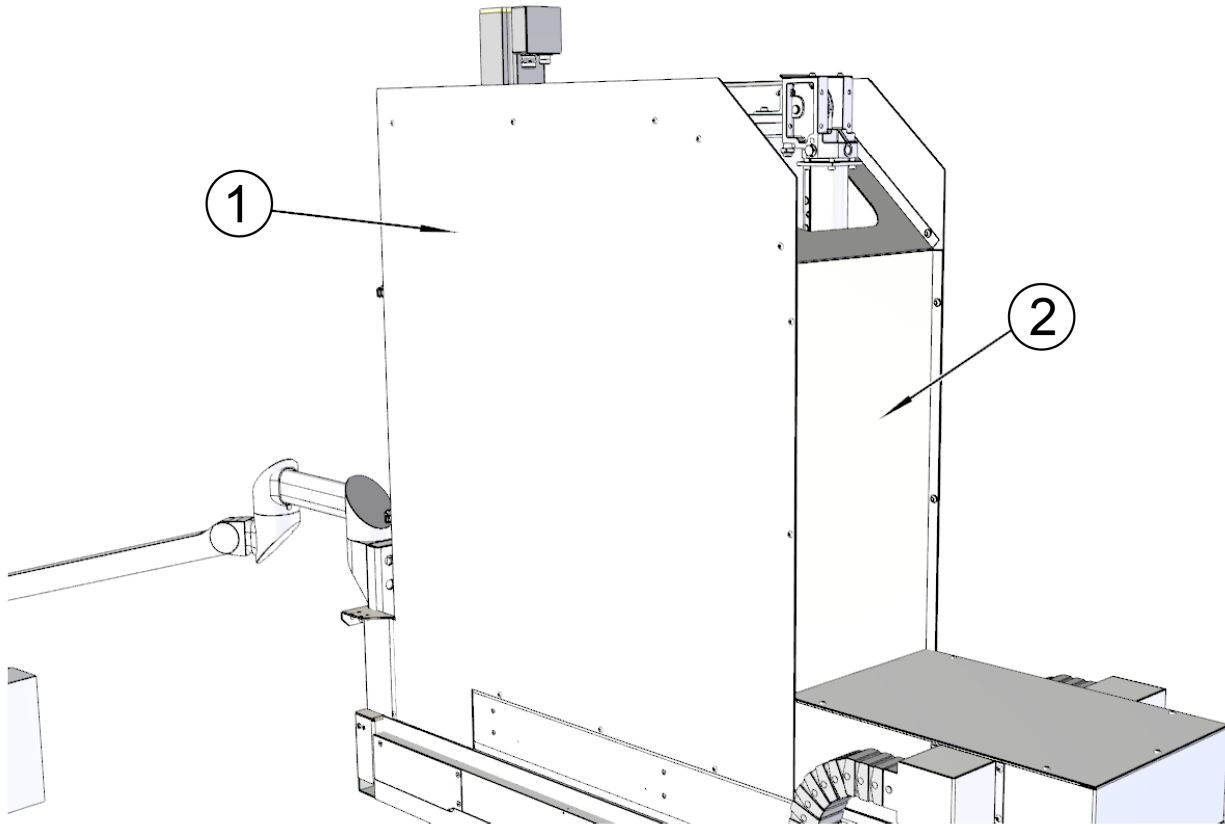

ITEM	PART #	DESCRIPTION
1	10016J	COVER, RIGHT SIDE - REAR TOWER
2	10016F	REAR COVER - TOWER



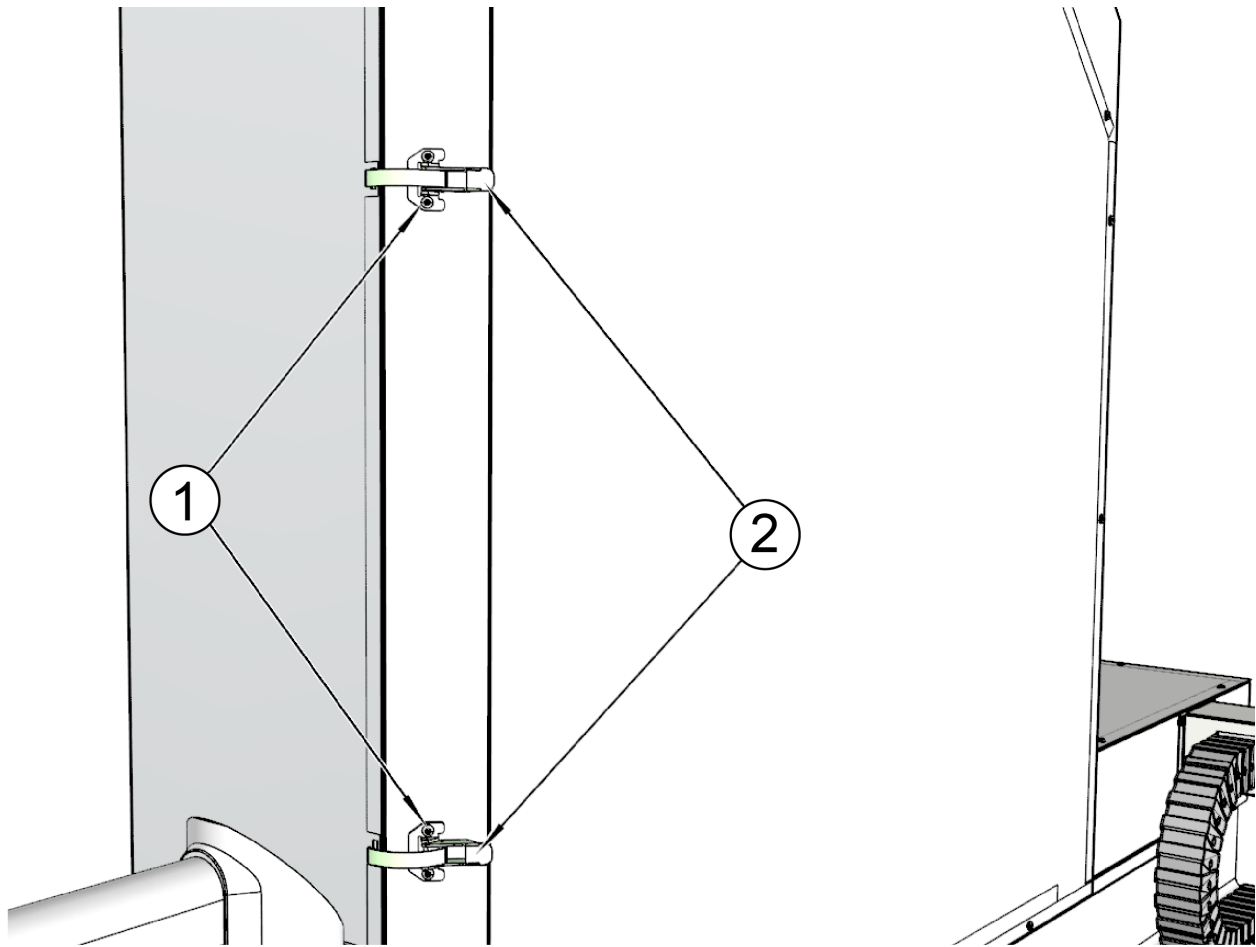

ITEM	PART #	DESCRIPTION
1	MF-87	SOCKET BUTTON HEAD SCREW 10-24 X 1/4"
2	6320M	CLAMP, SPINDLE COVER

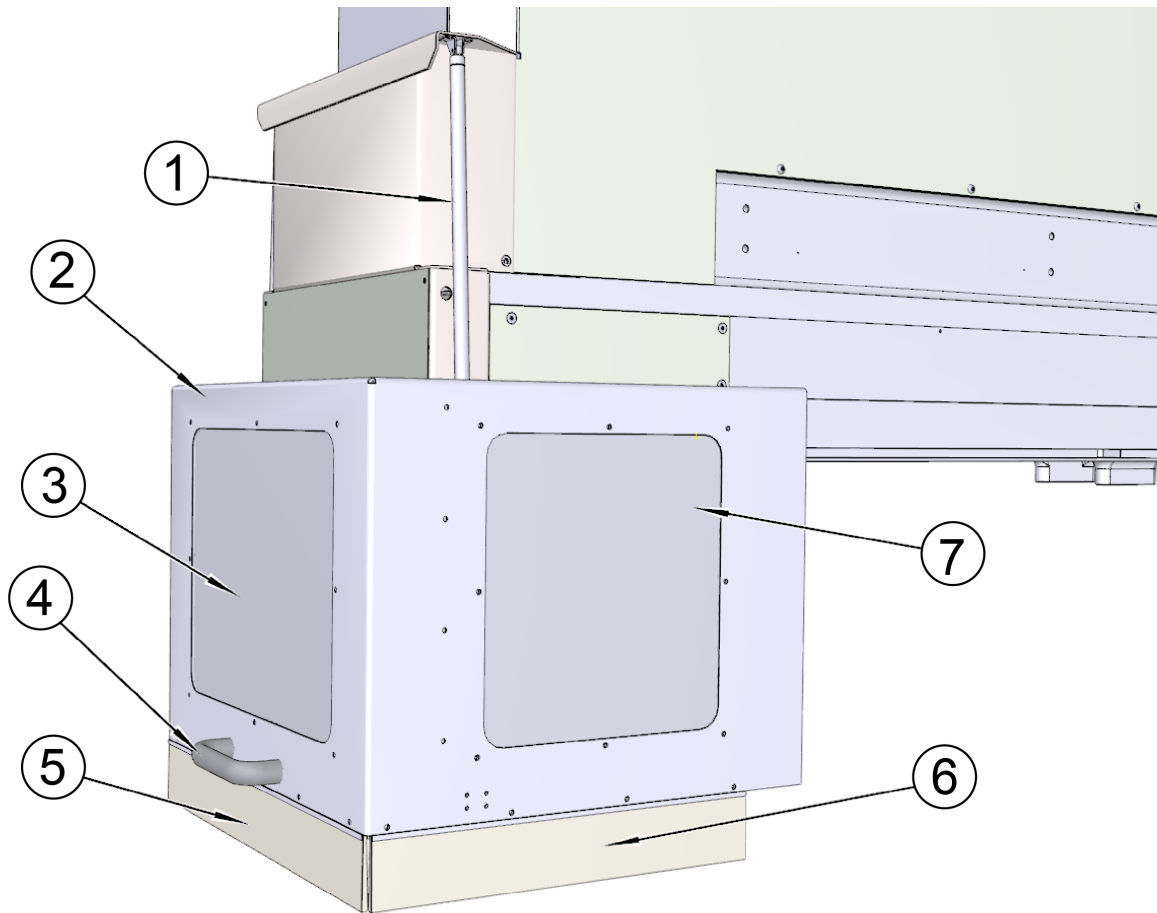
**Chip Shield****Outside Parts**

ITEM	PART #	DESCRIPTION
1	11030B	HEXAGON SOCKET BUTTON HEAD CAP SCREW-METRIC
2	9221	CHIP SHIELD
3	9221B	FRONT LEXAN WINDOW
4	650-1-29G	HANDLE, TOUCH PANEL
5	11031H	BRUSH (24.77" LONG),CHIP SHIELD
6	11031E	BRUSH (19.5" LONG),CHIP SHIELD
7	9221A	SIDE LEXAN WINDOW

## Inside Parts

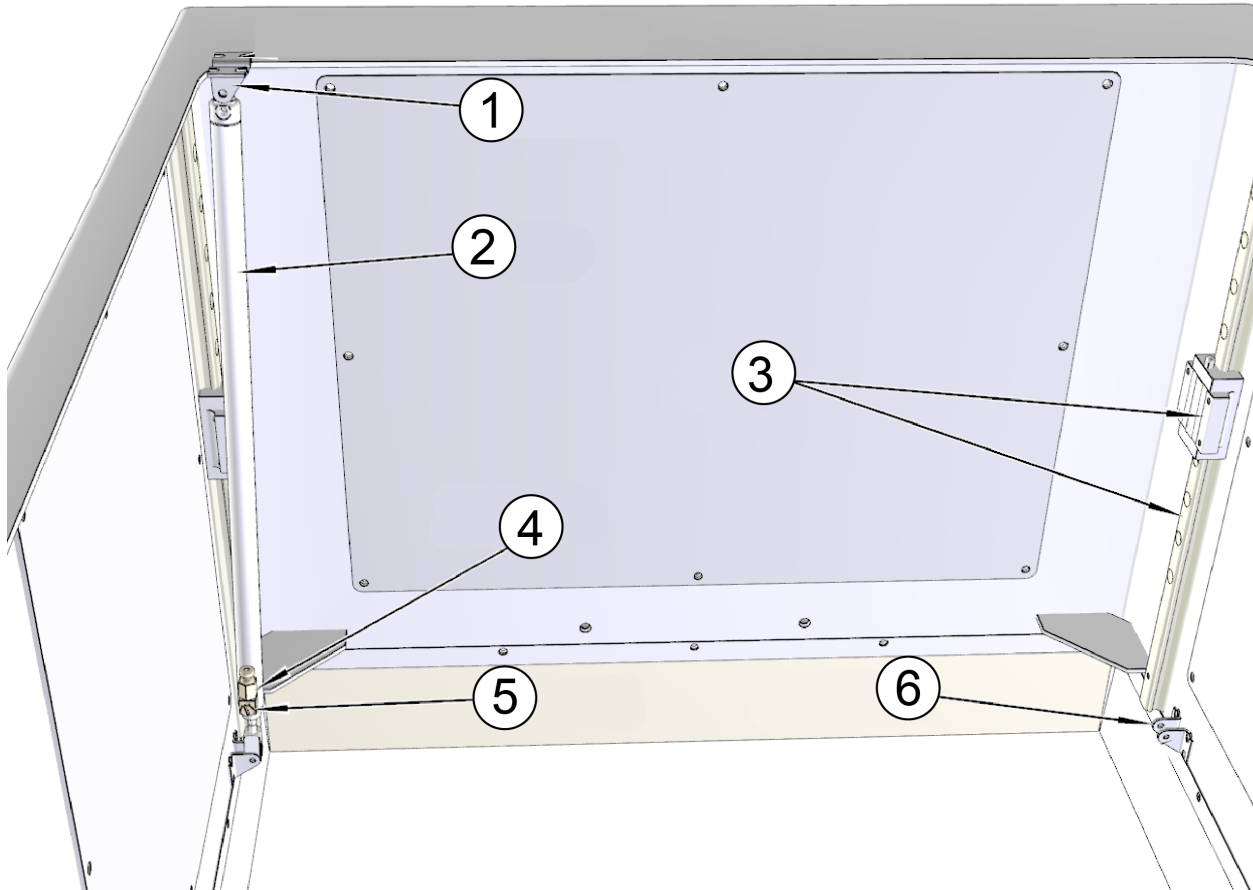

ITEM	PART #	DESCRIPTION
1	11032C	BRACKET KIT ,AIR CYLINDER
2	11030B	HEXAGON SOCKET BUTTON HEAD CAP SCREW-METRIC
3	11033	LINEAR RAIL
4	514-4-17J	CONNECTOR, MALE - 1/8" OD TO 10-32
5	514-4-16A	FITTING, ADJUSTABLE "L"
6	11032C	BRACKET KIT ,AIR CYLINDER

Oil Line Diagrams

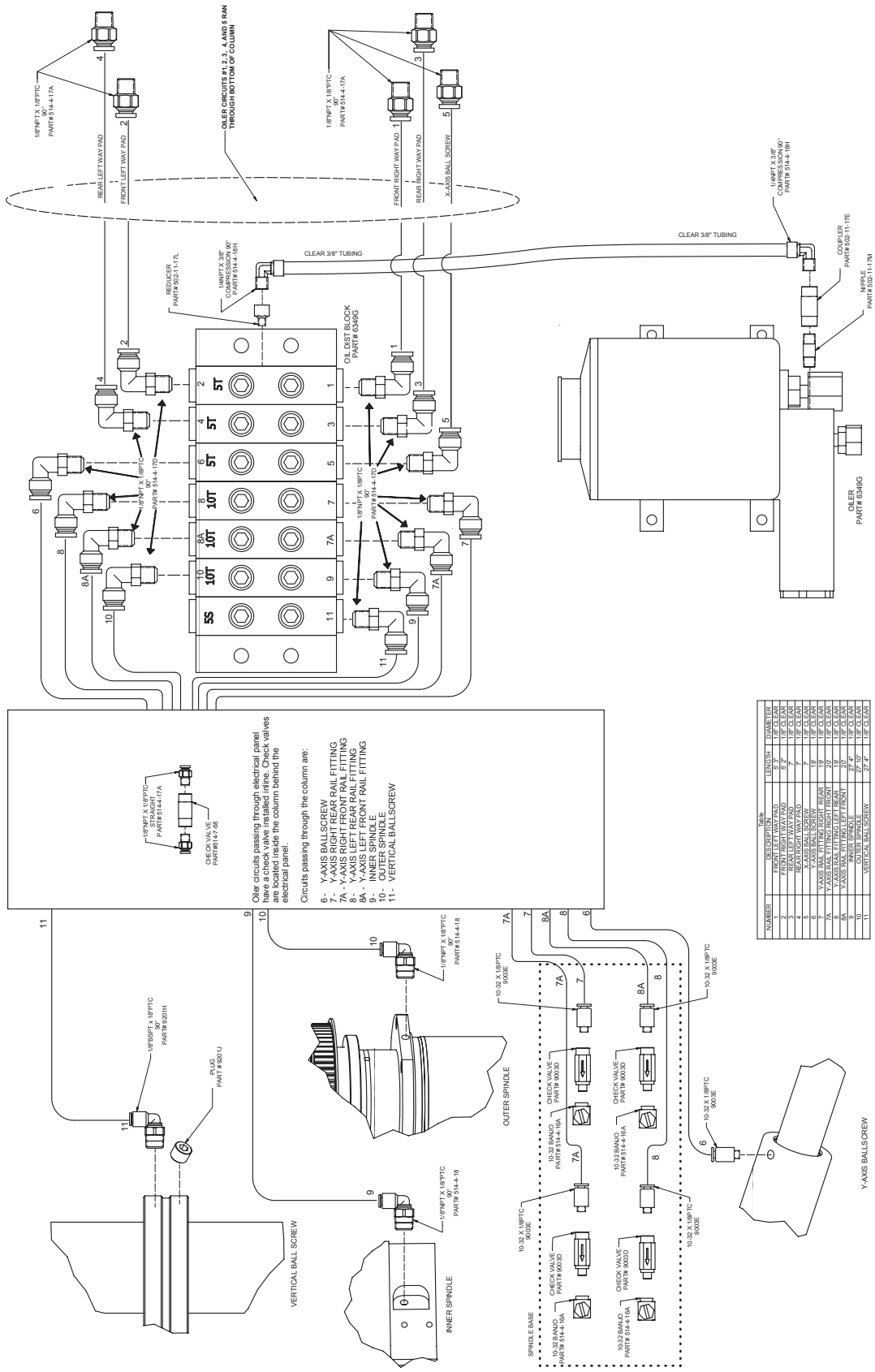

**Air Line Diagram**

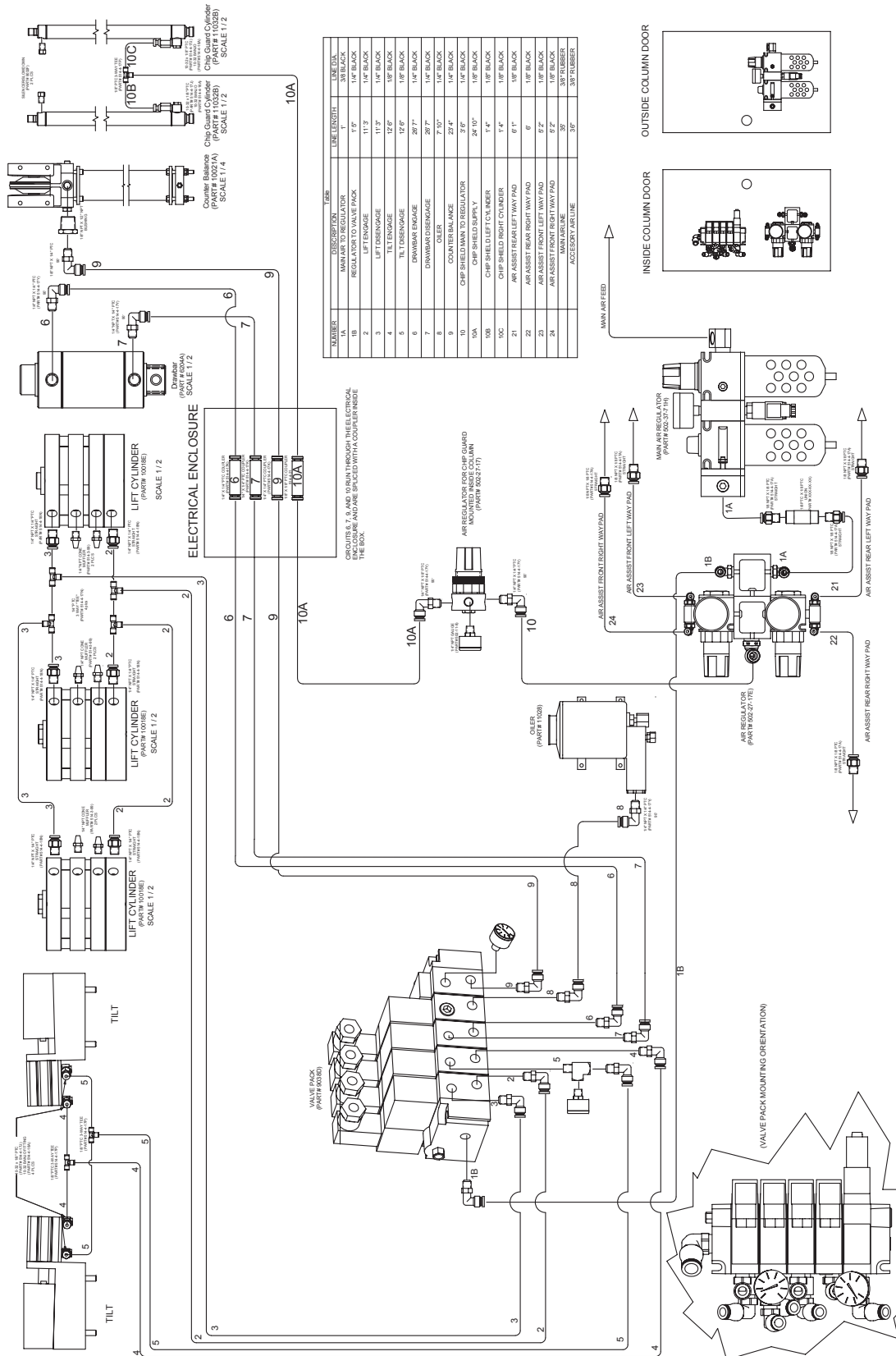

# Electrical Wiring Diagram

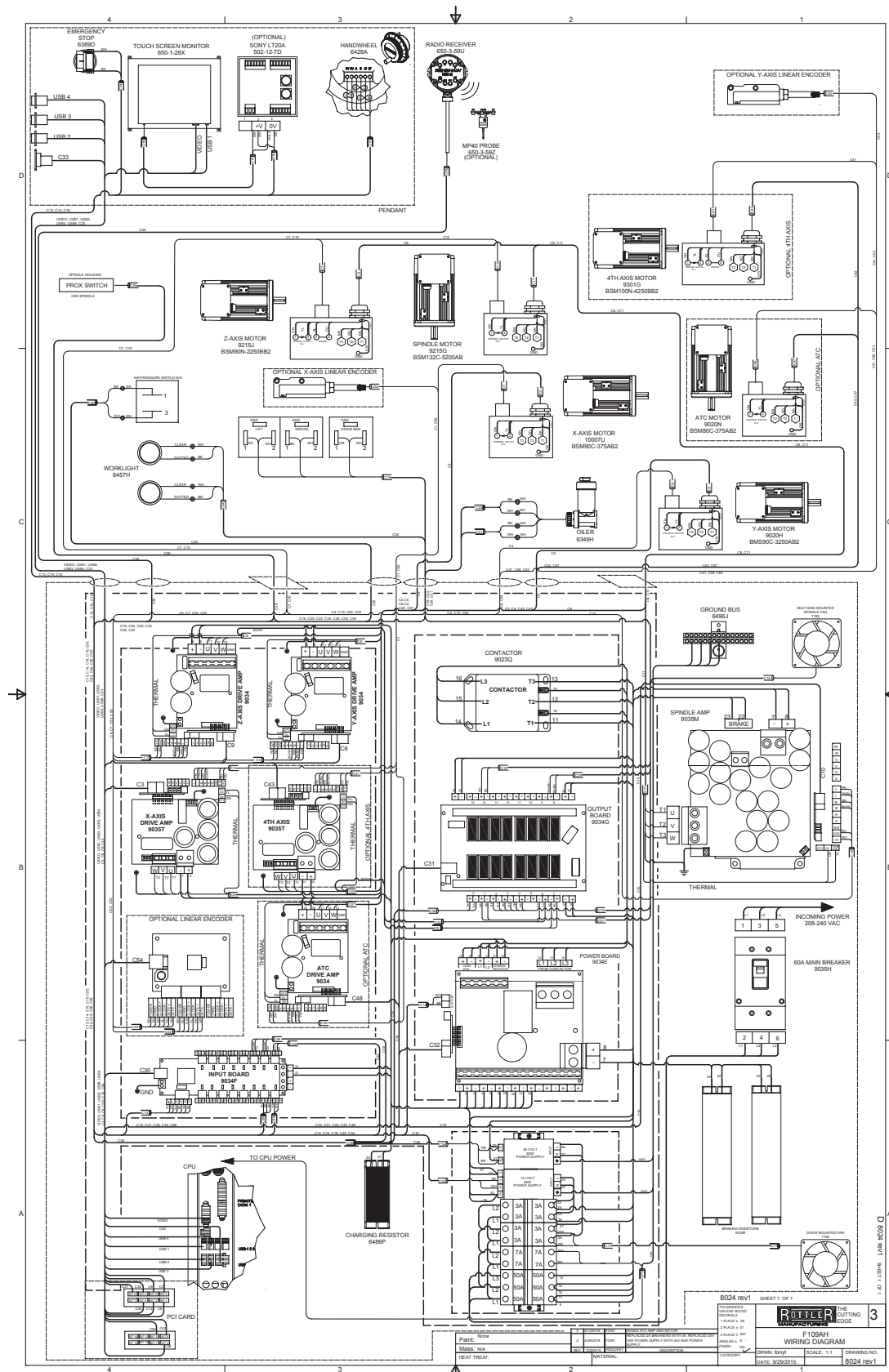

## Electrical Enclosure

### Outside Parts

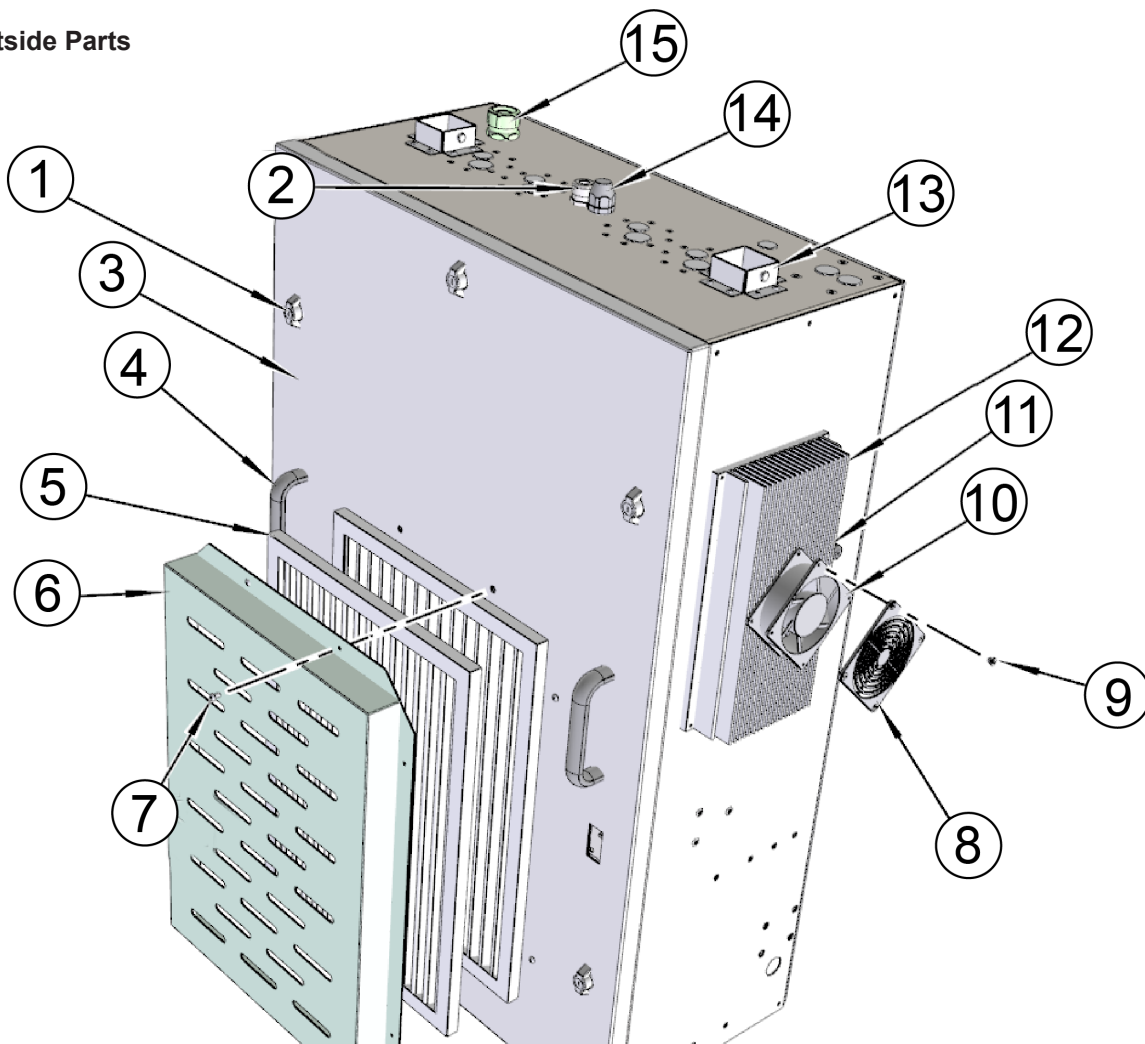

ITEM	PART #	DESCRIPTION
1	9035E	DOOR LATCH
2		STRAIN RELIEF
3	9030A	DOOR,ELECTRICAL ENCLOSURE
4	650-1-29G	HANDLE
5	9030P	AIR FILTER
6	9030H	FILTER HOUSING
7	MF-88	SOCKET BUTTON HEAD SCREW 10-24 X 3/8"
8	7192B	GUARD, FAN
9		10-24 X 1/4 FLAT HEAD CAP SCREW
10	7192	FAN
11	502-37-71N	STRAIN RELIEF
12	9023Z	SPINDLE AMP HEAT SINK
13	9023P	SPINDLE WIRING TRACK BRACKET
14	502-2-23C	STRAIGHT CONDUIT FITTING
15	6358	CONNECTOR,STRAIGHT-1"

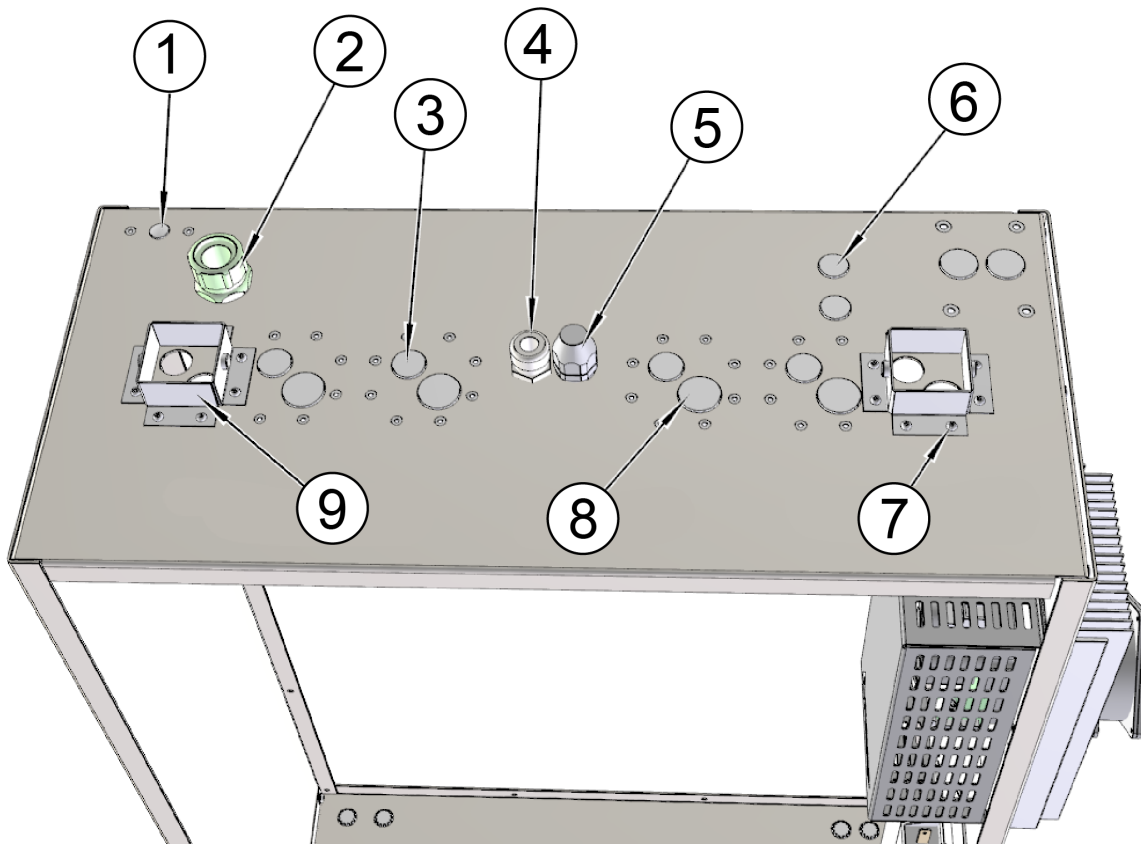

ITEM	PART #	DESCRIPTION
1	506-3	PLUG, SNAP IN HOLE - 1/2"
2	6358	CONNECTOR, STRAIGHT-1"
3	506-4	PLUG, SNAP IN HOLE - 1"
4		STRAIN RELIEF
5	502-2-23C	STRAIGHT CONDUIT FITTINGS FOR 3/8" EXTRA FLEXIBLE CONDUIT
6	506-3-1	PLUG, SNAP IN HOLE-7/8"
7	MF-86B	SOCKET BUTTON HEAD SCREW 8-32 X 3/16
8	506-3-4	PLUG, SNAP IN HOLE-1 1/4"
9	9023P	SPINDLE WIRING TRACK BRACKET



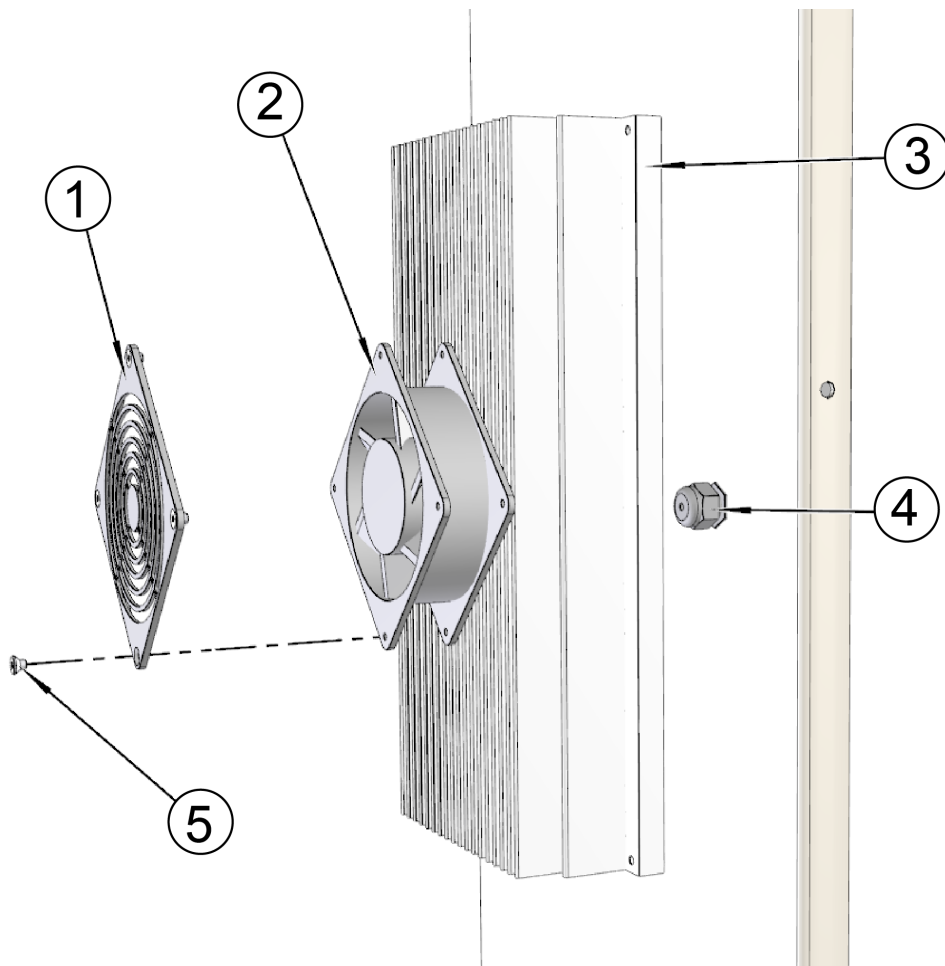

ITEM	PART #	DESCRIPTION
1	7192B	GUARD, FAN
2	7192	FAN, ELECTRONIC ENCLOSURE
3	9023Z	SPINDLE AMP HEAT SINK
4	502-37-71N	STRAIN RELIEF
5		10-24 X 1/4 FLAT HEAD SOCKET SCREW

## Enclosure Door

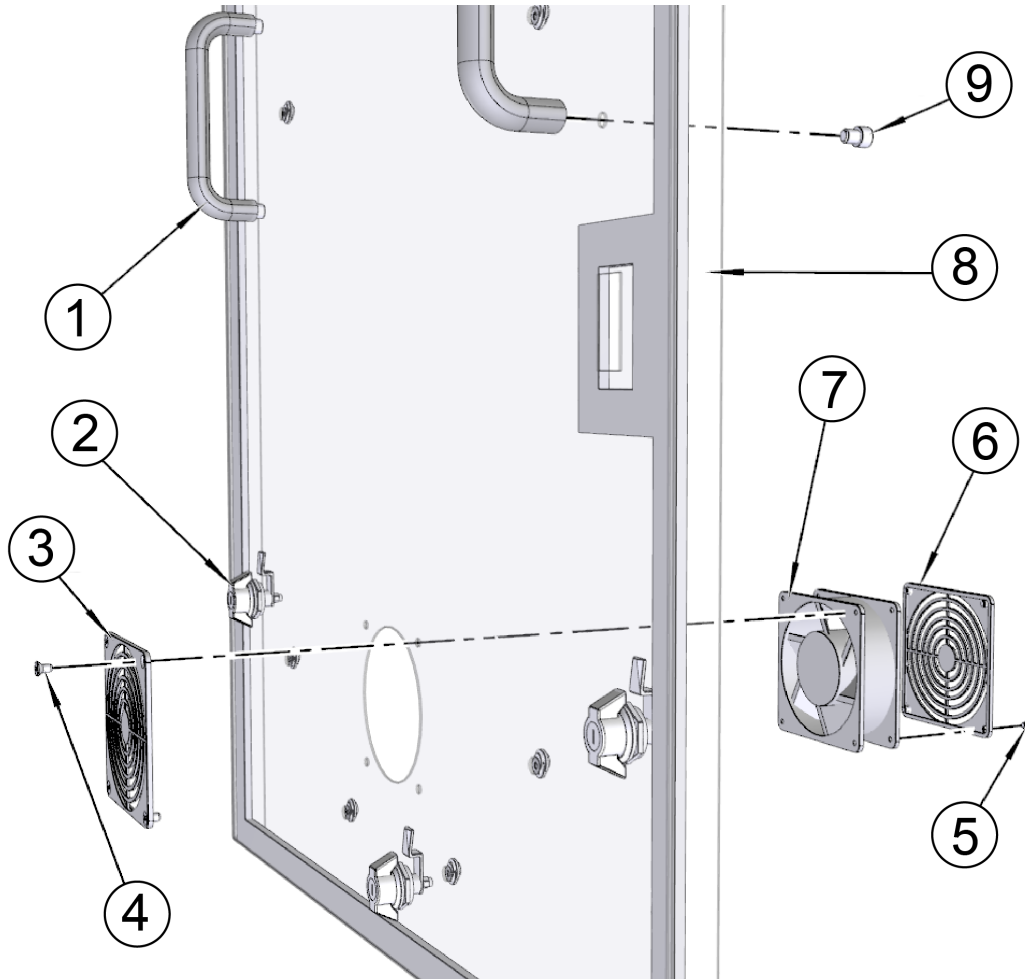

ITEM	PART #	DESCRIPTION
1	650-1-29G	HANDLE, TOUCH PANEL
2	9035E	DOOR LATCH
3	7192B	GUARD, FAN
4	MF-78	SOCKET FLAT HEAD SCREW 10-24 X 3/8"
5		10-24 X 1/4 FLAT HEAD CAP SCREW
6	7192B	GUARD, FAN
7	7192	FAN, ELECTRONIC ENCLOSURE
8	9030A	DOOR,ELECTRICAL ENCLOSURE
9	MF-21B	SOCKET HEAD CAP SCREW 5/16-18 X 3/8"

Inside Parts

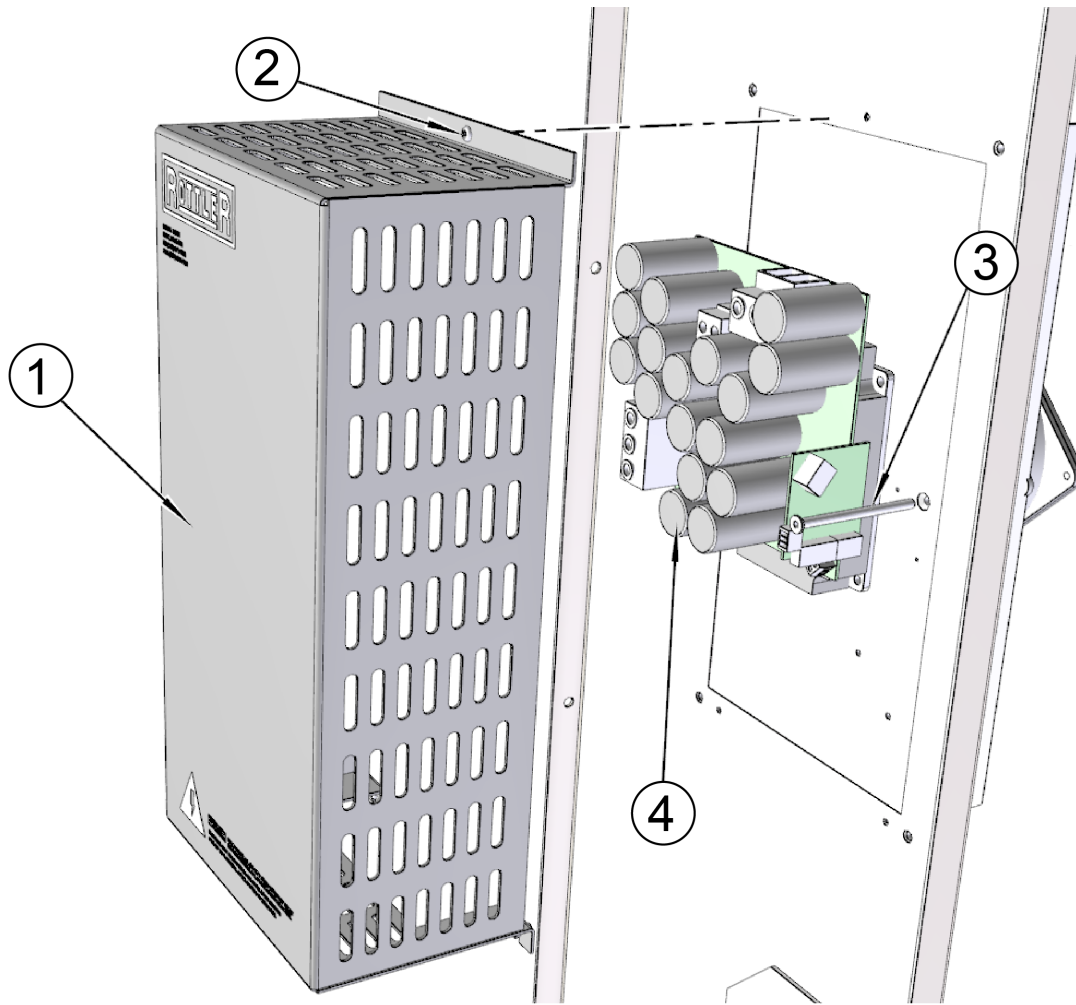

ITEM	PART #	DESCRIPTION
1	9023L	SPINDLE AMP DRIVE COVER
2		6-32 X BUTTON HEAD CAP SCREW
3		10-24 X 3 FLAT HEAD CAP SCREW
4	9035N	DM 300 AMP SPINDLE DRIVE

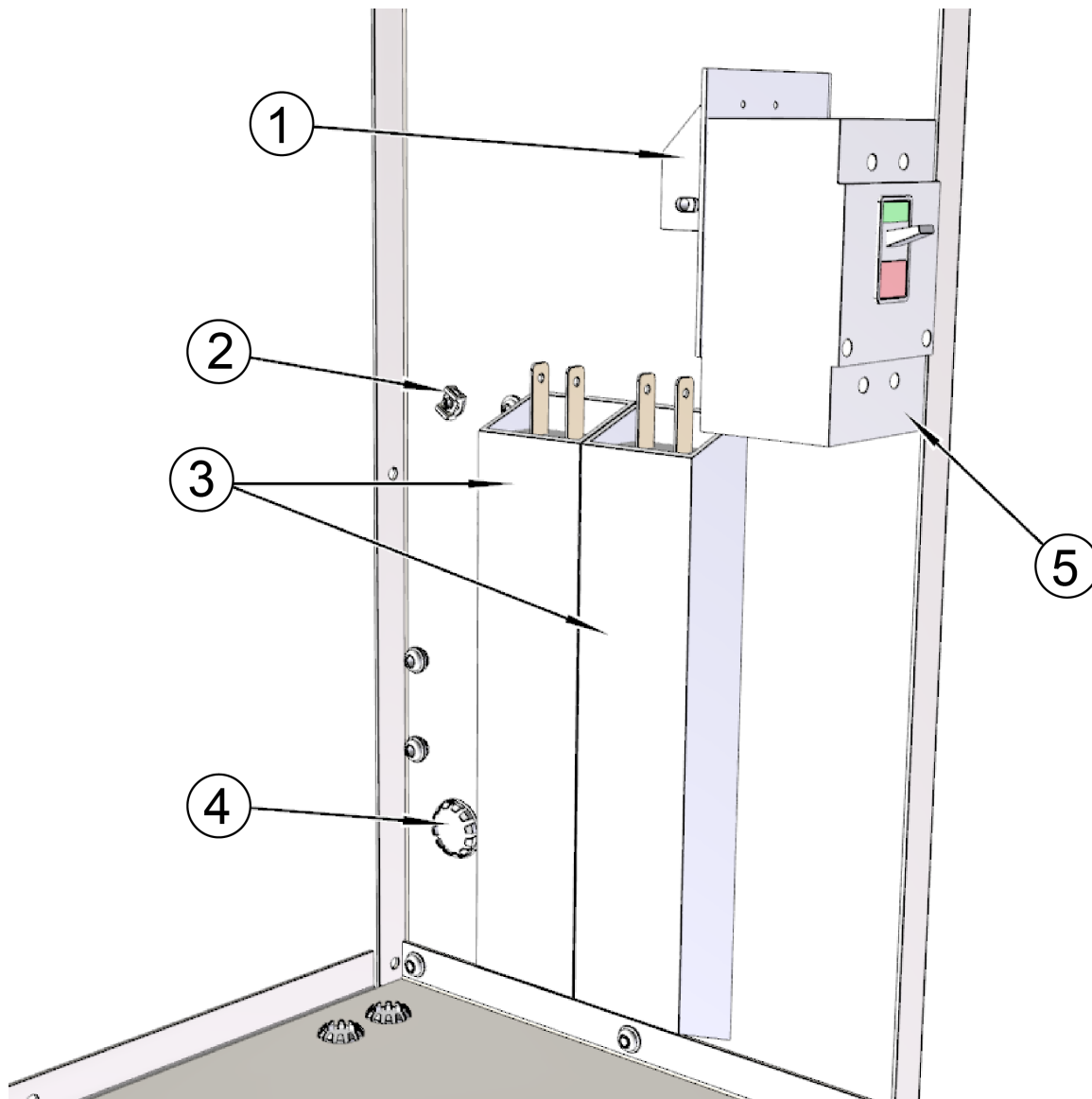

ITEM	PART #	DESCRIPTION
1	9030T	BRACKET, SWITCH
2	6147C	HOLDER, SCREW MOUNT TYRAP
3	9038E	RESISTOR, BRAKING
4	506-3-4	PLUG, SNAP IN HOLE-1 1/4"
5	9035H	CIRCUIT BREAKER-60 AMP-MAIN POWER

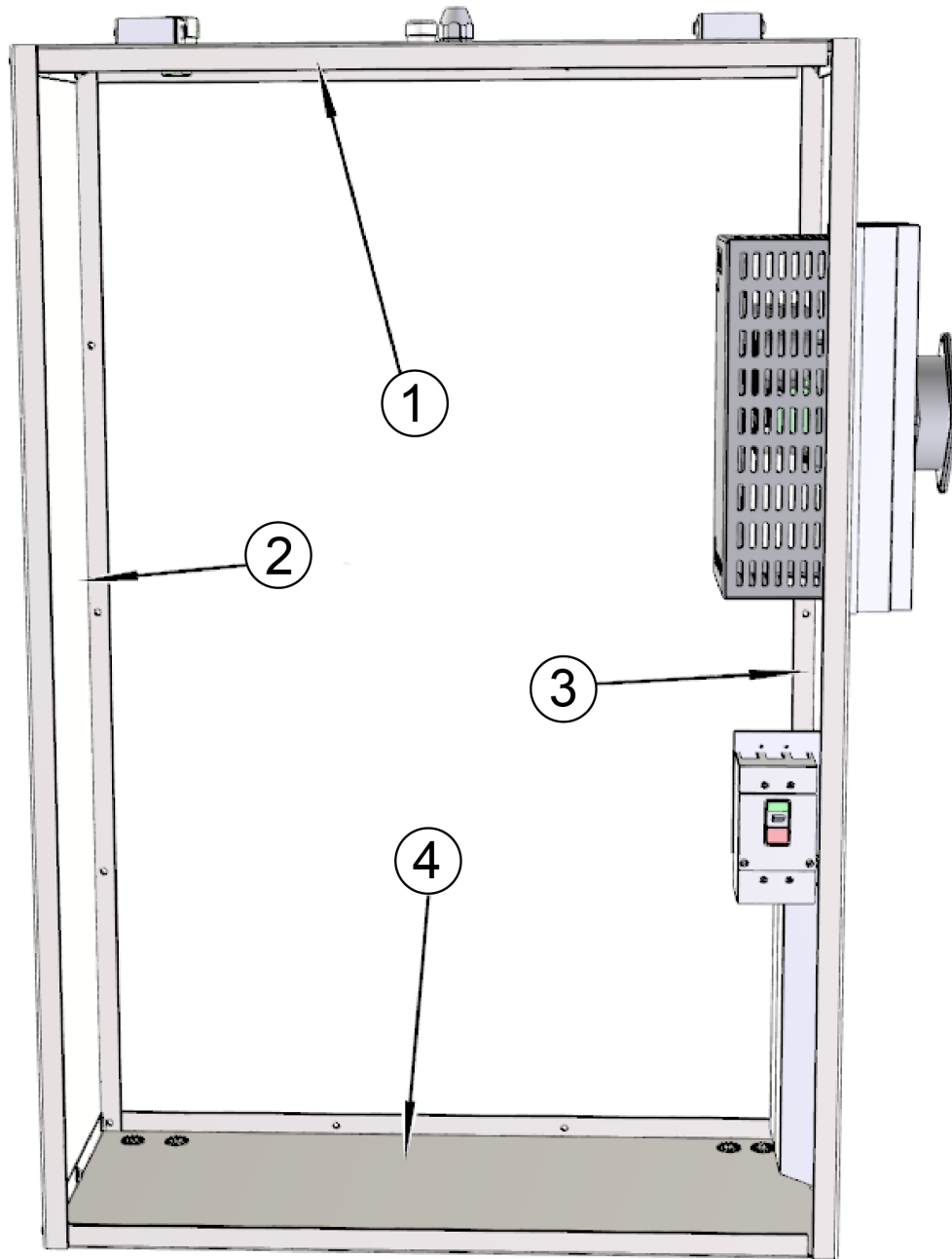

ITEM	PART #	DESCRIPTION
1	9033C	TOP SIDE PANEL
2	9033B	LEFT SIDE PANEL
3	9033A	RIGHT SIDE PANEL
4	9033D	BOTTOM SIDE PANEL

## Electrical Panel Parts

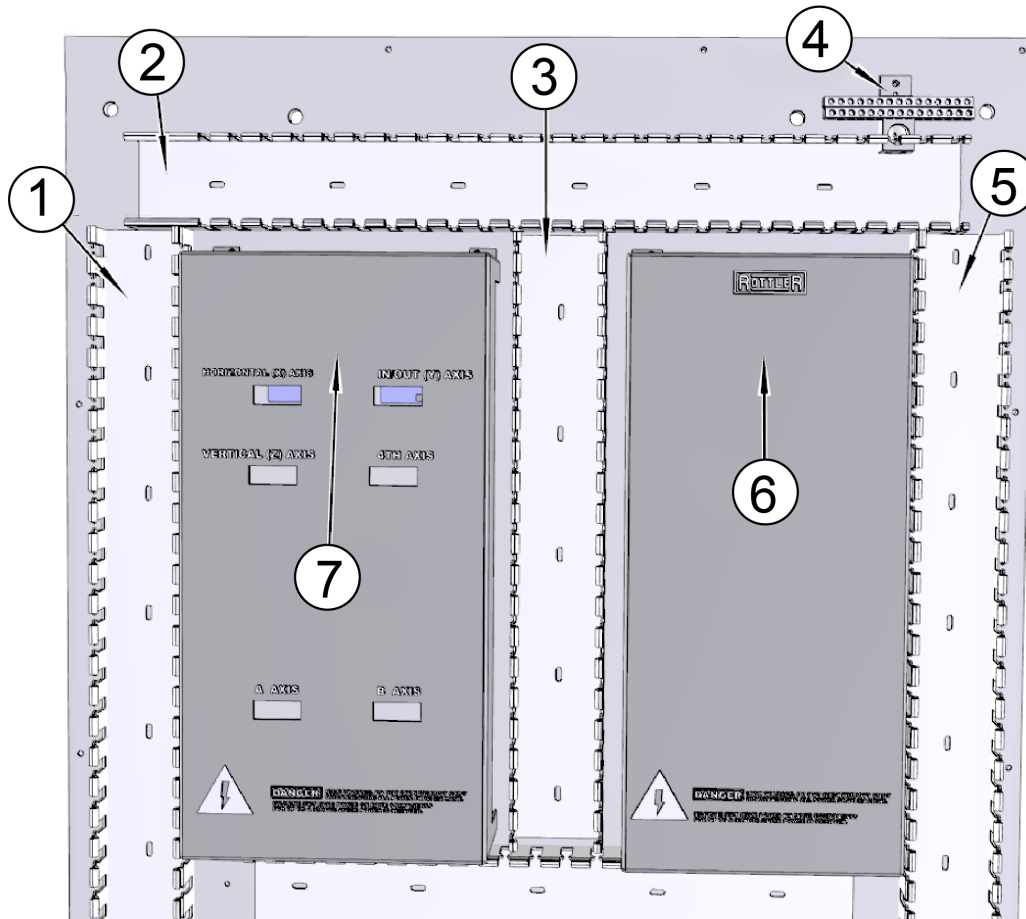

ITEM	PART #	DESCRIPTION
1	6554L	DUCT, WIRING 38"
2	6554L	DUCT, WIRING 27"
3	6554L	DUCT, WIRING 15"
4	6496J	TERMINAL, GROUNDING
5	6554L	DUCT, WIRING 38"
6	9030G	COVER-ELECTRICAL COMPONENTS
7	9030F	DRIVE COVER

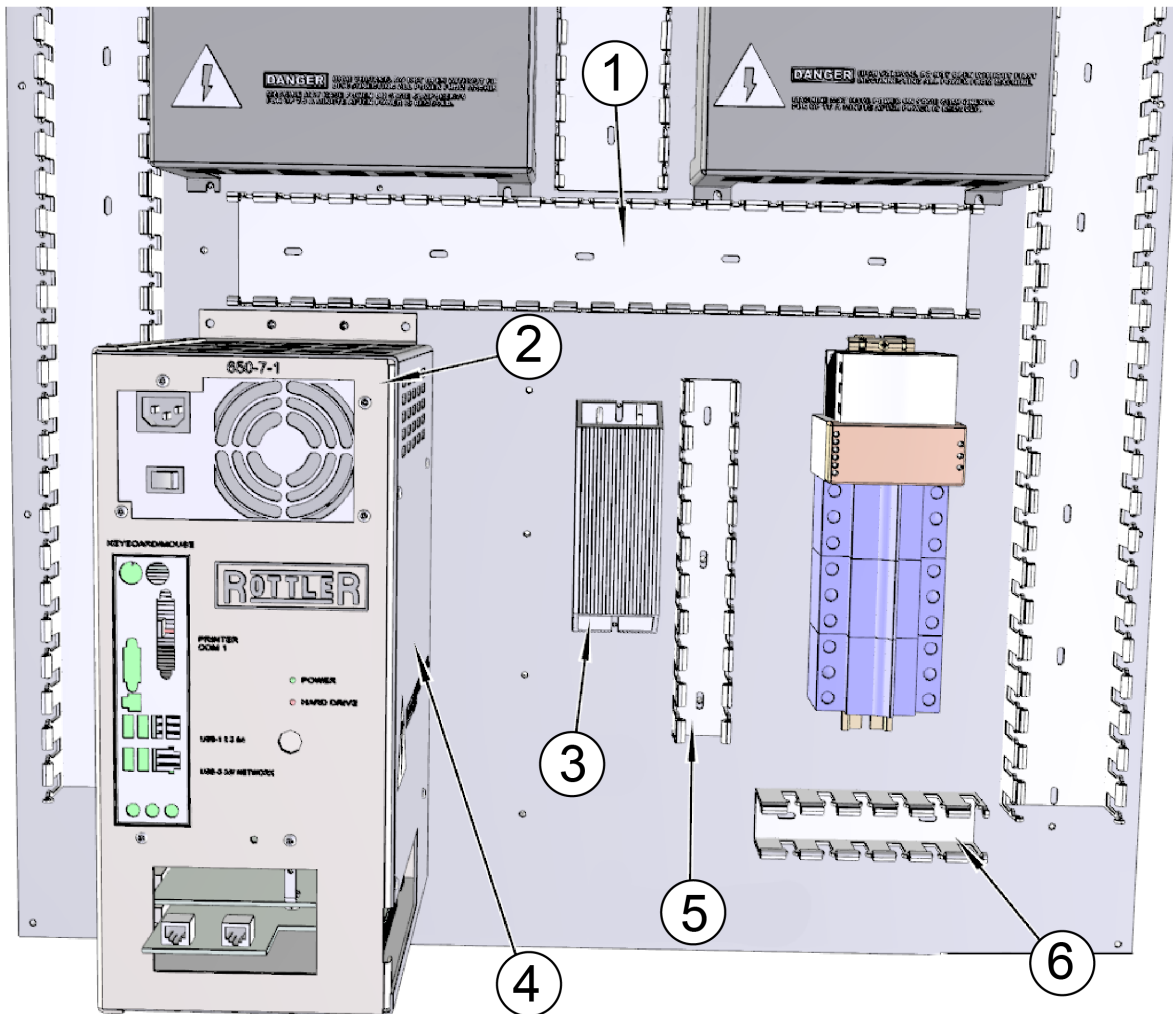

ITEM	PART #	DESCRIPTION
1	6554L	DUCT, WIRING 15"
2	650-1-27Y	FRAME, COMPUTER CASE
3	6486P	200 WATT, 10 OHM CHARGE RESISTOR
4	650-1-27Z	COVER, COMPUTER CASE
5	6554L	DUCT, WIRING 10"
6	6554L	DUCT, WIRING 6"

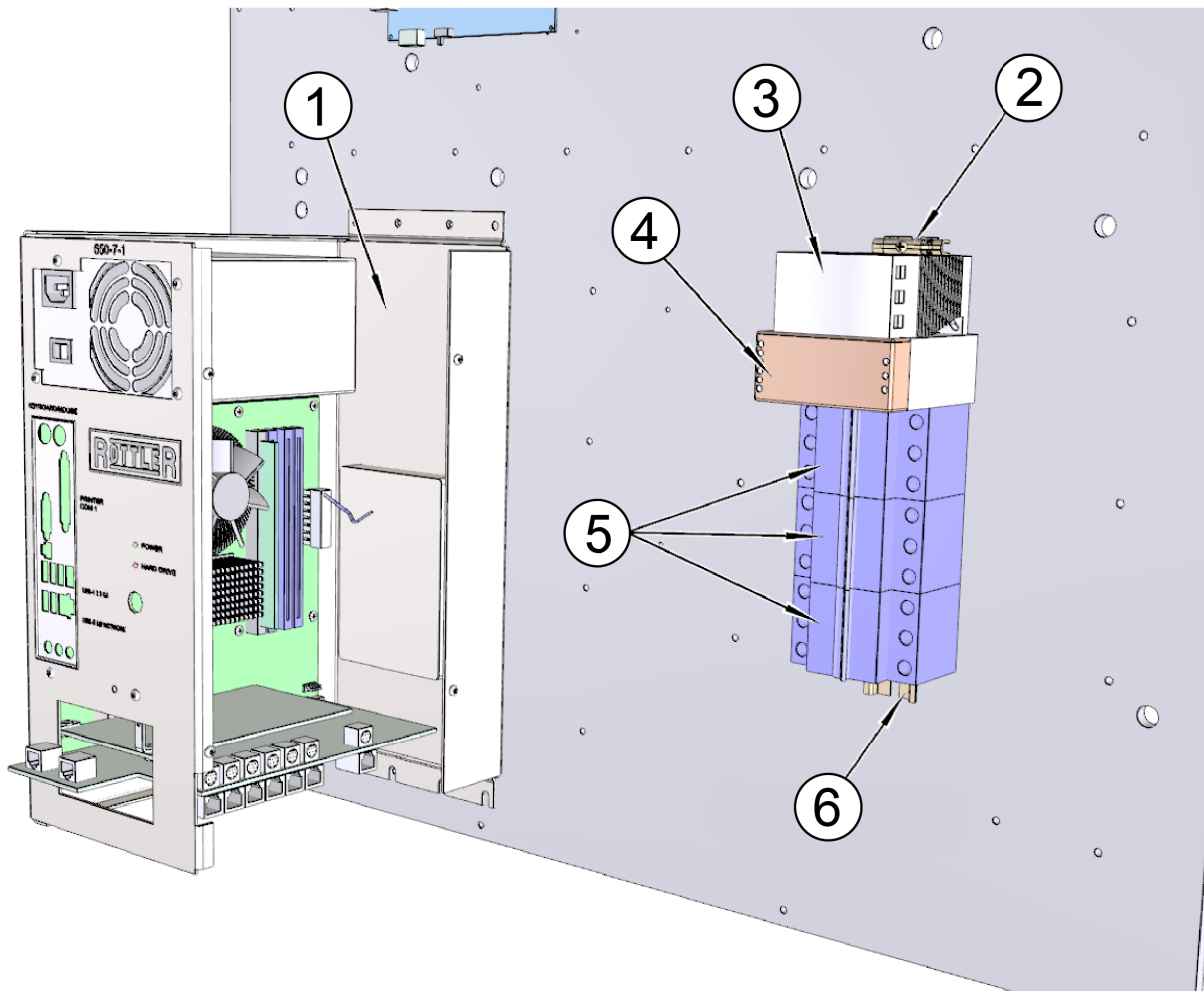

ITEM	PART #	DESCRIPTION
1	650-7-1	COMPUTER ASSEMBLY
2	504-35-3M	CAP, DIN RAIL
3	504-35-3K	POWER SUPPLY, 24 VOLT DC
4	9038C	100 WATT, 12 VDC POWER SUPPLY
5	6462E	BREAKER, CIRCUIT 60 AMP 3 POLE
6	504-35-3F	DIN RAIL 11"



**Computer Components**

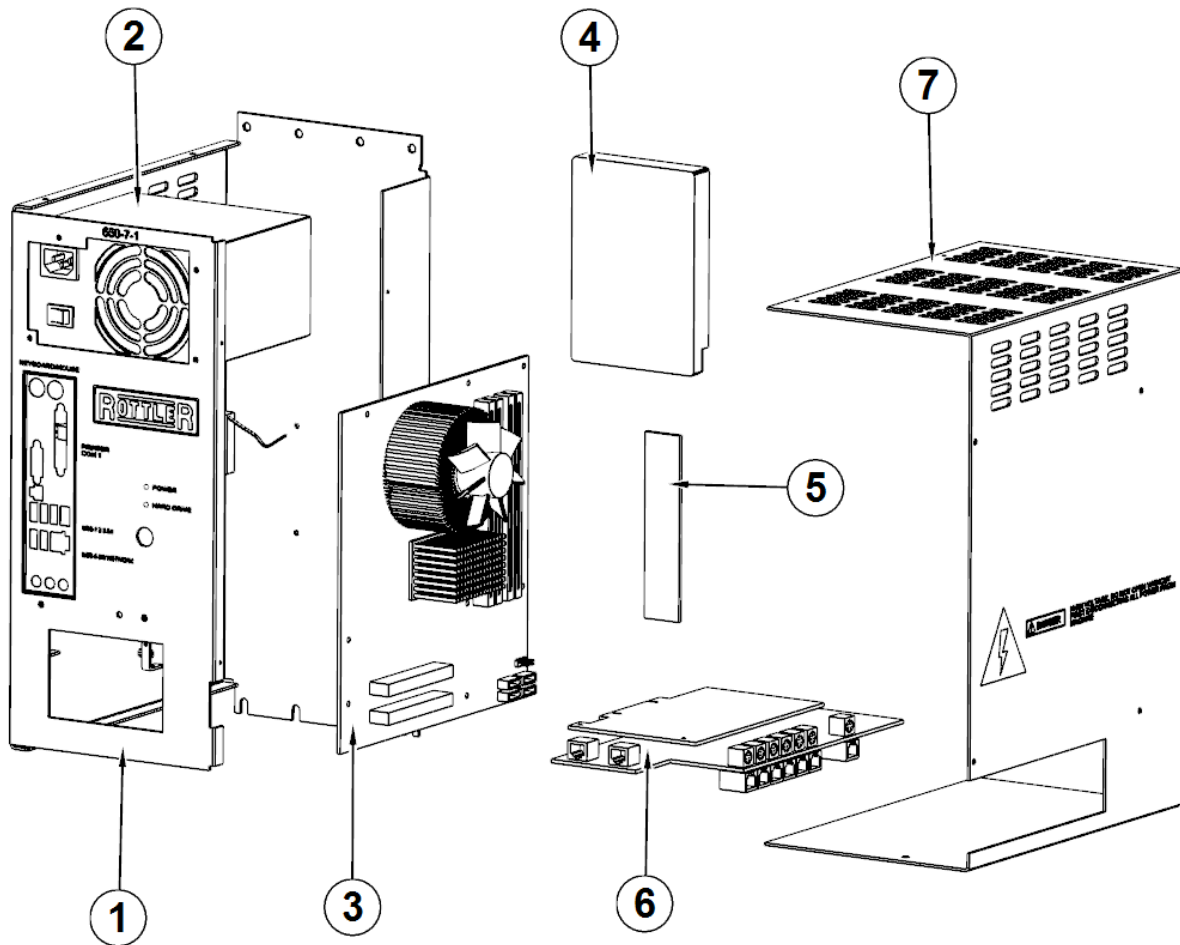

ITEM	PART #	DESCRIPTION
1	650-1-27Y	FRAME,COMPUTER CASE--SOLD IN ASSY #650-1-27X
2	650-7-1C	400W POWER SUPPLY
3	650-7-1A	MOTHER BOARD
4	650-7-1F	HARD DRIVE
5	650-7-2F	8GB DDR4 RAM
6	9035D	PCI E CARD - 16 LINK
7	650-1-27Z	COVER,COMPUTER CASE-SOLD IN ASSY #650-1-27X

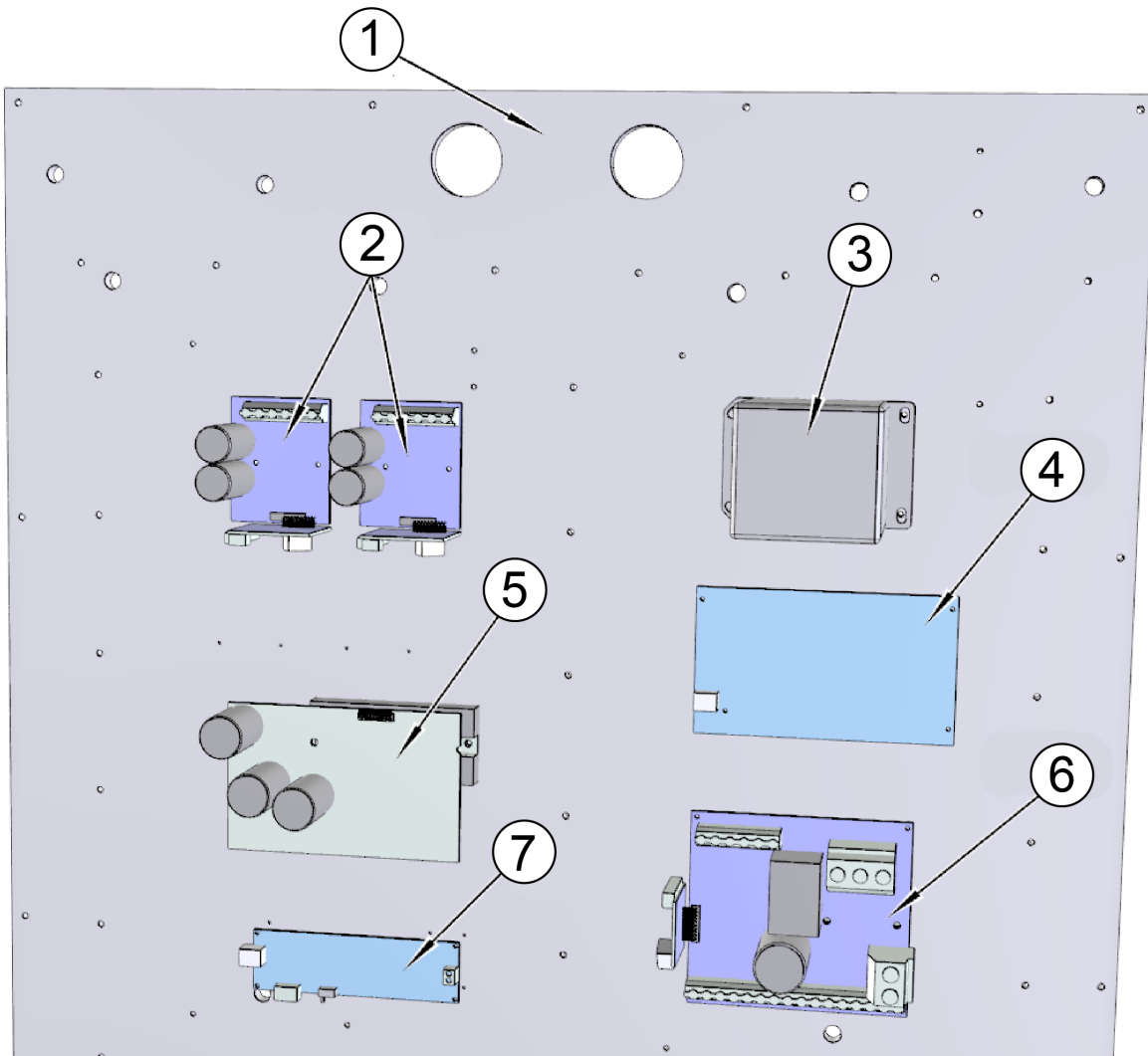

ITEM	PART #	DESCRIPTION
1	9035	ALUMINUM PANEL-REAR ENCLOSURE
2	9034	DM 30 AMP AXIS DRIVE
3	9023Q	CONTACTOR-90 AMP SPINDLE AMP
4	9034G	OUTPUT BOARD
5	9034B	DM 100 AMP SPINDLE DRIVE
6	9034E	POWER BOARD-70 AMP
7	9034F	INPUT BOARD

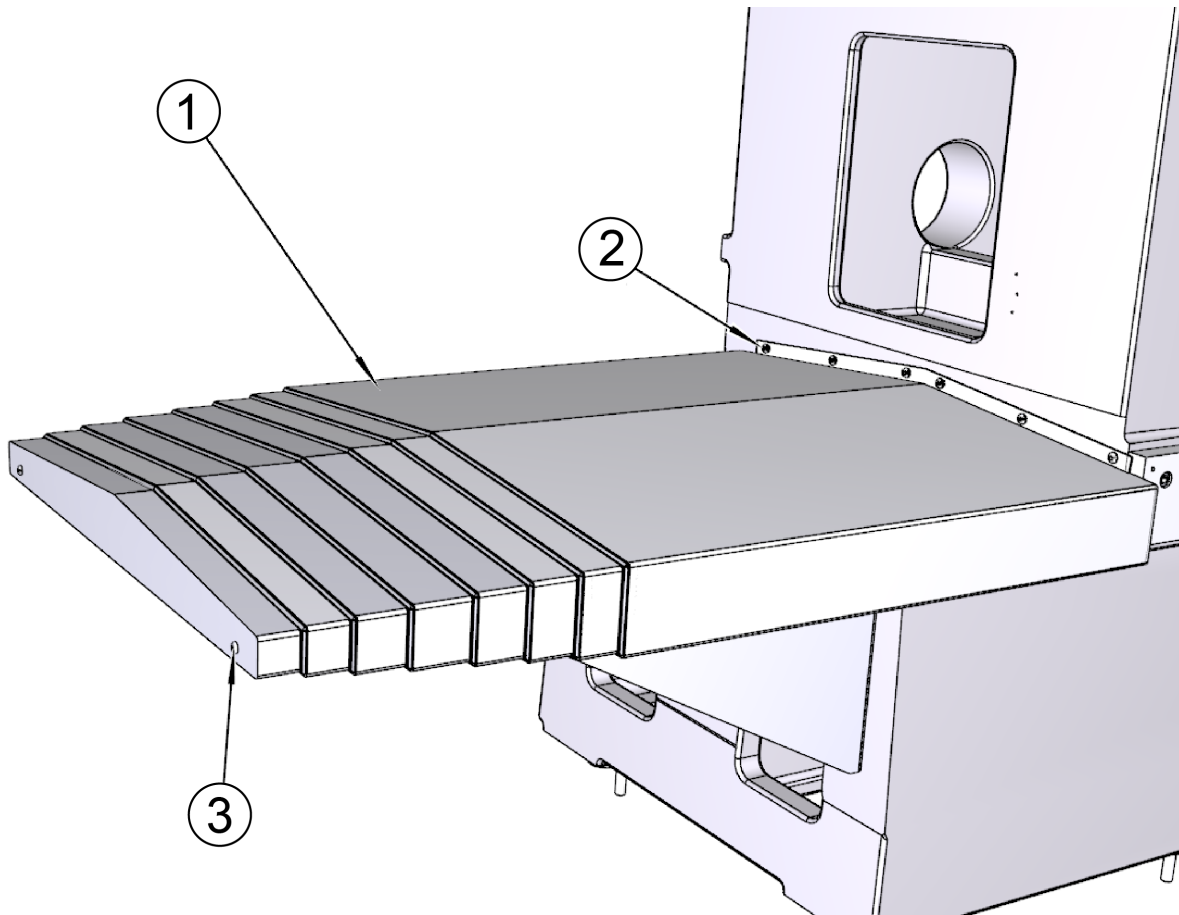
**Way Covers**

ITEM	PART #	DESCRIPTION
1	10024J	WAY COVER SET WITH WIPERS
2	MF-97	SOCKET BUTTON HEAD SCREW 3/8-16 X 5/8"
3	MF-93A	SOCKET BUTTON HEAD SCREW 5/16-18 X 1/2"

## Way Cover Supports

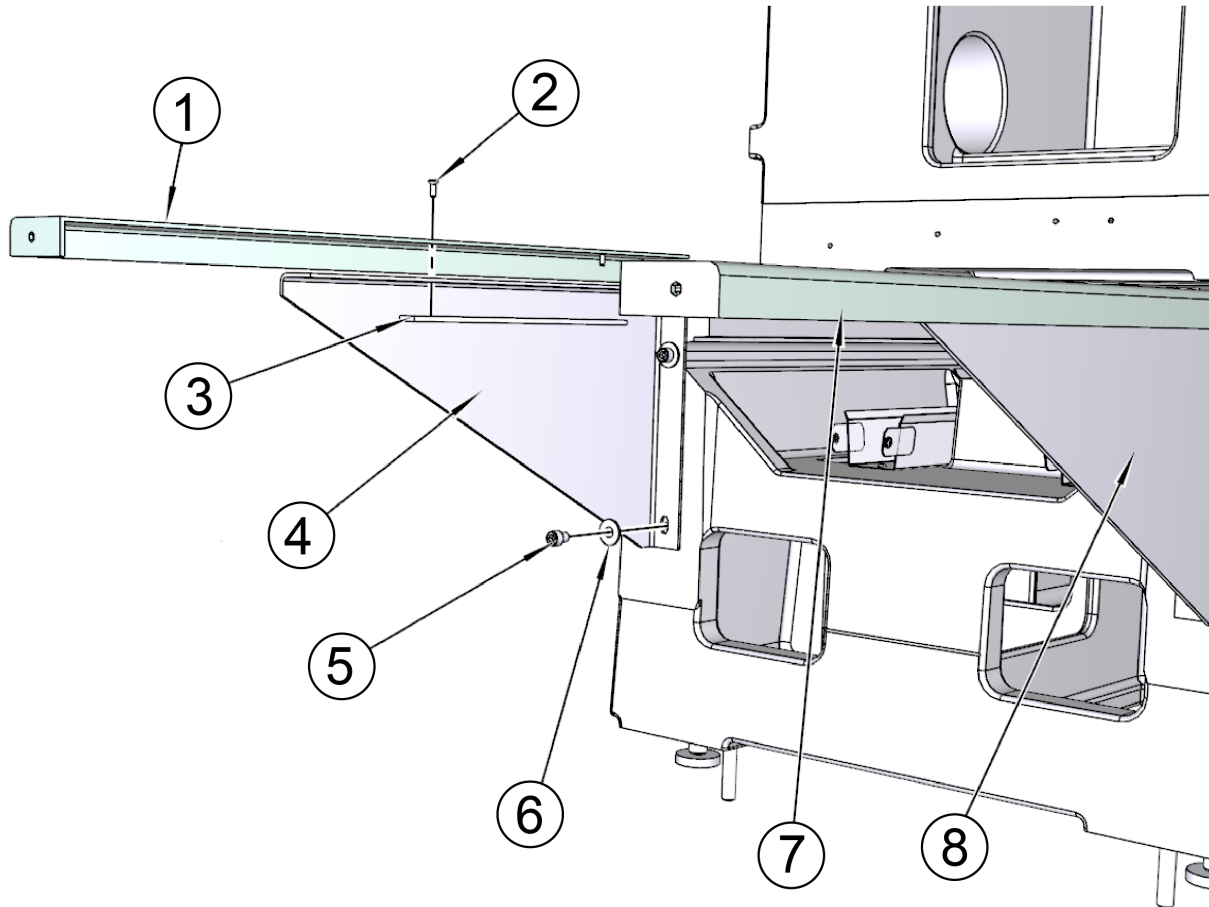

ITEM	PART #	DESCRIPTION
1	10025B	WAYCOVER EXTENSION-LEFT HORIZONTAL
2	MF-83	SOCKET FLAT HEAD SCREW 1/4-20 X 3/4"
3	9011E	CLAMP BAR-WAYCOVER SUPPORT ASSEMBLY
4	10025	WAY COVER SUPPORT-LEFT HORIZONTAL
5		1/2-13 X 5/8 SOCKET HEAD CAP SCREW
6	MF-180	FLAT WASHERS 1/2"
7	10025C	WAYCOVER EXTENSION-RIGHT HORIZONTAL
8	10025A	WAYCOVER SUPPORT-RIGHT HORIZONTAL

This page intentionally left blank

# OPTIONS

## Optional Equipment

Optional Equipment Catalog and Parts Manual are located on the Manual CD shipped with machine.



# MSDS

The Material Data Safety Sheets list shown in this section are the substances and materials that an operator is most likely to come in contact with while using this machine.

Other substances and materials are used in the manufacture, testing, and shipping of this machine. A complete list of the Material Data Safety Sheets of substances and materials used by Rottler Manufacturing during manufacturing, testing, and shipping is located on the Manual CD shipped with the machine. Material Data Safety Sheets are also located on the company web site: <http://www.rottlermfg.com/documentation.php>

## 1) Mobil Vactra Oil #2





Product Name: MOBIL VACTRA OIL NO. 2  
 Revision Date: 17 Oct 2008  
 Page 1 of 8

## MATERIAL SAFETY DATA SHEET

### SECTION 1 PRODUCT AND COMPANY IDENTIFICATION

#### PRODUCT

**Product Name:** MOBIL VACTRA OIL NO. 2  
**Product Description:** Base Oil and Additives  
**Product Code:** 600494-00, 970716  
**Intended Use:** Lubricant

#### COMPANY IDENTIFICATION

**Supplier:** EXXON MOBIL CORPORATION  
 3225 GALLOWS RD.  
 FAIRFAX, VA. 22037 USA

**24 Hour Health Emergency:** 609-737-4411  
**Transportation Emergency Phone:** 800-424-9300  
**ExxonMobil Transportation No.:** 281-834-3296  
**Product Technical Information:** 800-662-4525, 800-947-9147  
**MSDS Internet Address:** <http://www.exxon.com>, <http://www.mobil.com>

### SECTION 2 COMPOSITION / INFORMATION ON INGREDIENTS

No Reportable Hazardous Substance(s) or Complex Substance(s).

### SECTION 3 HAZARDS IDENTIFICATION

This material is not considered to be hazardous according to regulatory guidelines (see (M)SDS Section 15).

#### POTENTIAL HEALTH EFFECTS

Low order of toxicity. Excessive exposure may result in eye, skin, or respiratory irritation. High-pressure injection under skin may cause serious damage.

**NFPA Hazard ID:** Health: 0 Flammability: 1 Reactivity: 0  
**HMIS Hazard ID:** Health: 0 Flammability: 1 Reactivity: 0

**NOTE:** This material should not be used for any other purpose than the intended use in Section 1 without expert advice. Health studies have shown that chemical exposure may cause potential human health risks which may vary from person to person.

### SECTION 4 FIRST AID MEASURES

#### INHALATION

Remove from further exposure. For those providing assistance, avoid exposure to yourself or others. Use adequate respiratory protection. If respiratory irritation, dizziness, nausea, or unconsciousness occurs, seek immediate medical assistance. If breathing has stopped, assist ventilation with a mechanical device or use



Product Name: MOBIL VACTRA OIL NO. 2  
Revision Date: 17Oct2008  
Page 2 of 8

mouth-to-mouth resuscitation.

#### SKIN CONTACT

Wash contact areas with soap and water. If product is injected into or under the skin, or into any part of the body, regardless of the appearance of the wound or its size, the individual should be evaluated immediately by a physician as a surgical emergency. Even though initial symptoms from high pressure injection may be minimal or absent, early surgical treatment within the first few hours may significantly reduce the ultimate extent of injury.

#### EYE CONTACT

Flush thoroughly with water. If irritation occurs, get medical assistance.

#### INGESTION

First aid is normally not required. Seek medical attention if discomfort occurs.

### SECTION 5 FIRE FIGHTING MEASURES

#### EXTINGUISHING MEDIA

**Appropriate Extinguishing Media:** Use water fog, foam, dry chemical or carbon dioxide (CO<sub>2</sub>) to extinguish flames.

**Inappropriate Extinguishing Media:** Straight Streams of Water

#### FIRE FIGHTING

**Fire Fighting Instructions:** Evacuate area. Prevent runoff from fire control or dilution from entering streams, sewers, or drinking water supply. Firefighters should use standard protective equipment and in enclosed spaces, self-contained breathing apparatus (SCBA). Use water spray to cool fire exposed surfaces and to protect personnel.

**Hazardous Combustion Products:** Smoke, Fume, Aldehydes, Sulfur oxides, Incomplete combustion products, Oxides of carbon

#### FLAMMABILITY PROPERTIES

**Flash Point [Method]:** >205C (401F) [ASTM D-92]

**Flammable Limits (Approximate volume % in air):** LEL: 0.9 UEL: 7.0

**Autoignition Temperature:** N/D

### SECTION 6 ACCIDENTAL RELEASE MEASURES

#### NOTIFICATION PROCEDURES

In the event of a spill or accidental release, notify relevant authorities in accordance with all applicable regulations. US regulations require reporting releases of this material to the environment which exceed the applicable reportable quantity or oil spills which could reach any waterway including intermittent dry creeks. The National Response Center can be reached at (800)424-8802.

#### SPILL MANAGEMENT



Product Name: MOBIL VACTRA OIL NO. 2  
Revision Date: 17Oct2008  
Page 3 of 8

**Land Spill:** Stop leak if you can do it without risk. Recover by pumping or with suitable absorbent.

**Water Spill:** Stop leak if you can do it without risk. Confine the spill immediately with booms. Warn other shipping. Remove from the surface by skimming or with suitable absorbents. Seek the advice of a specialist before using dispersants.

Water spill and land spill recommendations are based on the most likely spill scenario for this material; however, geographic conditions, wind, temperature, (and in the case of a water spill) wave and current direction and speed may greatly influence the appropriate action to be taken. For this reason, local experts should be consulted. Note: Local regulations may prescribe or limit action to be taken.

#### ENVIRONMENTAL PRECAUTIONS

Large Spills: Dike far ahead of liquid spill for later recovery and disposal. Prevent entry into waterways, sewers, basements or confined areas.

### SECTION 7 HANDLING AND STORAGE

#### HANDLING

Prevent small spills and leakage to avoid slip hazard.

**Static Accumulator:** This material is a static accumulator.

#### STORAGE

Do not store in open or unlabelled containers. Keep away from incompatible materials.

### SECTION 8 EXPOSURE CONTROLS / PERSONAL PROTECTION

**Exposure limits/standards for materials that can be formed when handling this product:** When mists / aerosols can occur, the following are recommended: 5 mg/m<sup>3</sup> - ACGIH TLV, 10 mg/m<sup>3</sup> - ACGIH STEL, 5 mg/m<sup>3</sup> - OSHA PEL.

NOTE: Limits/standards shown for guidance only. Follow applicable regulations.

#### ENGINEERING CONTROLS

The level of protection and types of controls necessary will vary depending upon potential exposure conditions. Control measures to consider:

No special requirements under ordinary conditions of use and with adequate ventilation.

#### PERSONAL PROTECTION

Personal protective equipment selections vary based on potential exposure conditions such as applications, handling practices, concentration and ventilation. Information on the selection of protective equipment for use with this material, as provided below, is based upon intended, normal usage.

**Respiratory Protection:** If engineering controls do not maintain airborne contaminant concentrations at a level which is adequate to protect worker health, an approved respirator may be appropriate. Respirator



Product Name: MOBIL VACTRA OIL NO. 2  
 Revision Date: 17 Oct 2008  
 Page 4 of 8

selection, use, and maintenance must be in accordance with regulatory requirements, if applicable. Types of respirators to be considered for this material include:

No special requirements under ordinary conditions of use and with adequate ventilation.

For high airborne concentrations, use an approved supplied-air respirator, operated in positive pressure mode. Supplied air respirators with an escape bottle may be appropriate when oxygen levels are inadequate, gas/vapor warning properties are poor, or if air purifying filter capacity/rating may be exceeded.

**Hand Protection:** Any specific glove information provided is based on published literature and glove manufacturer data. Glove suitability and breakthrough time will differ depending on the specific use conditions. Contact the glove manufacturer for specific advice on glove selection and breakthrough times for your use conditions. Inspect and replace worn or damaged gloves. The types of gloves to be considered for this material include:

No protection is ordinarily required under normal conditions of use.

**Eye Protection:** If contact is likely, safety glasses with side shields are recommended.

**Skin and Body Protection:** Any specific clothing information provided is based on published literature or manufacturer data. The types of clothing to be considered for this material include:

No skin protection is ordinarily required under normal conditions of use. In accordance with good industrial hygiene practices, precautions should be taken to avoid skin contact.

**Specific Hygiene Measures:** Always observe good personal hygiene measures, such as washing after handling the material and before eating, drinking, and/or smoking. Routinely wash work clothing and protective equipment to remove contaminants. Discard contaminated clothing and footwear that cannot be cleaned. Practice good housekeeping.

#### ENVIRONMENTAL CONTROLS

See Sections 6, 7, 12, 13.

### SECTION 9 PHYSICAL AND CHEMICAL PROPERTIES

Typical physical and chemical properties are given below. Consult the Supplier in Section 1 for additional data.

#### GENERAL INFORMATION

**Physical State:** Liquid  
**Color:** Brown  
**Odor:** Characteristic  
**Odor Threshold:** N/D

#### IMPORTANT HEALTH, SAFETY, AND ENVIRONMENTAL INFORMATION

**Relative Density (at 15 C):** 0.883  
**Flash Point [Method]:** >205C (401F) [ASTM D-92]  
**Flammable Limits (Approximate volume % in air):** LEL: 0.9 UEL: 7.0  
**Autoignition Temperature:** N/D  
**Boiling Point / Range:** N/D  
**Vapor Density (Air = 1):** > 2 at 101 kPa  
**Vapor Pressure:** <0.013 kPa (0.1 mm Hg) at 20 C  
**Evaporation Rate (n-butyl acetate = 1):** N/D  
**pH:** N/A



Product Name: MOBIL VACTRA OIL NO. 2  
 Revision Date: 17Oct2008  
 Page 5 of 8

**Log Pow (n-Octanol/Water Partition Coefficient):** >3.5  
**Solubility in Water:** Negligible  
**Viscosity:** 68 cSt (68 mm<sup>2</sup>/sec) at 40 C | 8.6 cSt (8.6 mm<sup>2</sup>/sec) at 100C  
**Oxidizing Properties:** See Sections 3, 15, 16.

#### OTHER INFORMATION

**Freezing Point:** N/D  
**Melting Point:** N/A  
**Pour Point:** -6°C (21°F)  
**DMSO Extract (mineral oil only), IP-346:** <3 %wt

### SECTION 10 STABILITY AND REACTIVITY

**STABILITY:** Material is stable under normal conditions.

**CONDITIONS TO AVOID:** Excessive heat. High energy sources of ignition.

**MATERIALS TO AVOID:** Strong oxidizers

**HAZARDOUS DECOMPOSITION PRODUCTS:** Material does not decompose at ambient temperatures.

**HAZARDOUS POLYMERIZATION:** Will not occur.

### SECTION 11 TOXICOLOGICAL INFORMATION

#### ACUTE TOXICITY

Route of Exposure	Conclusion / Remarks
<b>Inhalation</b>	
Toxicity (Rat): LC50 > 5000 mg/m <sup>3</sup>	Minimally Toxic. Based on test data for structurally similar materials.
Irritation: No end point data.	Negligible hazard at ambient/normal handling temperatures. Based on assessment of the components.
<b>Ingestion</b>	
Toxicity (Rat): LD50 > 5000 mg/kg	Minimally Toxic. Based on test data for structurally similar materials.
<b>Skin</b>	
Toxicity (Rabbit): LD50 > 5000 mg/kg	Minimally Toxic. Based on test data for structurally similar materials.
Irritation (Rabbit): Data available.	Negligible irritation to skin at ambient temperatures. Based on test data for structurally similar materials.
<b>Eye</b>	
Irritation (Rabbit): Data available.	May cause mild, short-lasting discomfort to eyes. Based on test data for structurally similar materials.

#### CHRONIC/OTHER EFFECTS

##### Contains:

Base oil severely refined: Not carcinogenic in animal studies. Representative material passes IP-346, Modified Ames test, and/or other screening tests. Dermal and inhalation studies showed minimal effects; lung non-specific infiltration of immune cells, oil deposition and minimal granuloma formation. Not sensitizing in test animals.



Product Name: MOBIL VACTRA OIL NO. 2  
 Revision Date: 17 Oct 2008  
 Page 6 of 8

Additional information is available by request.

**The following ingredients are cited on the lists below:** None.

	--REGULATORY LISTS SEARCHED--		
1 = NTP CARC	3 = IARC 1		5 = IARC 2B
2 = NTP SUS	4 = IARC 2A		6 = OSHA CARC

## SECTION 12 ECOLOGICAL INFORMATION

The information given is based on data available for the material, the components of the material, and similar materials.

### ECOTOXICITY

Material -- Not expected to be harmful to aquatic organisms.

### MOBILITY

Base oil component -- Low solubility and floats and is expected to migrate from water to the land. Expected to partition to sediment and wastewater solids.

### PERSISTENCE AND DEGRADABILITY

#### Biodegradation:

Base oil component -- Expected to be inherently biodegradable

### BIOACCUMULATION POTENTIAL

Base oil component -- Has the potential to bioaccumulate, however metabolism or physical properties may reduce the bioconcentration or limit bioavailability.

## SECTION 13 DISPOSAL CONSIDERATIONS

Disposal recommendations based on material as supplied. Disposal must be in accordance with current applicable laws and regulations, and material characteristics at time of disposal.

### DISPOSAL RECOMMENDATIONS

Product is suitable for burning in an enclosed controlled burner for fuel value or disposal by supervised incineration at very high temperatures to prevent formation of undesirable combustion products.

### REGULATORY DISPOSAL INFORMATION

RCRA Information: The unused product, in our opinion, is not specifically listed by the EPA as a hazardous waste (40 CFR, Part 261D), nor is it formulated to contain materials which are listed as hazardous waste. It does not exhibit the hazardous characteristics of ignitability, corrosivity or reactivity and is not formulated with contaminants as determined by the Toxicity Characteristic Leaching Procedure (TCLP). However, used product may be regulated.

**Empty Container Warning** Empty Container Warning (where applicable): Empty containers may contain residue and can be dangerous. Do not attempt to refill or clean containers without proper instructions. Empty drums should be



Product Name: MOBIL VACTRA OIL NO. 2  
 Revision Date: 17Oct2008  
 Page 7 of 8

completely drained and safely stored until appropriately reconditioned or disposed. Empty containers should be taken for recycling, recovery, or disposal through suitably qualified or licensed contractor and in accordance with governmental regulations. DO NOT PRESSURISE, CUT, WELD, BRAZE, SOLDER, DRILL, GRIND, OR EXPOSE SUCH CONTAINERS TO HEAT, FLAME, SPARKS, STATIC ELECTRICITY, OR OTHER SOURCES OF IGNITION. THEY MAY EXPLODE AND CAUSE INJURY OR DEATH.

#### SECTION 14 TRANSPORT INFORMATION

**LAND (DOT)** : Not Regulated for Land Transport

**LAND (TDG)** : Not Regulated for Land Transport

**SEA (IMDG)** : Not Regulated for Sea Transport according to IMDG-Code

**AIR (IATA)** : Not Regulated for Air Transport

#### SECTION 15 REGULATORY INFORMATION

**OSHA HAZARD COMMUNICATION STANDARD:** When used for its intended purposes, this material is not classified as hazardous in accordance with OSHA 29 CFR 1910.1200.

**NATIONAL CHEMICAL INVENTORY LISTING:** AICS, IECSC, DSL, EINECS, ENCS, KECI, PICCS, TSCA

**EPCRA:** This material contains no extremely hazardous substances.

**SARA (311/312) REPORTABLE HAZARD CATEGORIES:** None.

**SARA (313) TOXIC RELEASE INVENTORY:** This material contains no chemicals subject to the supplier notification requirements of the SARA 313 Toxic Release Program.

**The Following Ingredients are Cited on the Lists Below:** None.

--REGULATORY LISTS SEARCHED--

1 = ACGIH ALL	6 = TSCA 5a2	11 = CA P65 REPRO	16 = MN RTK
2 = ACGIH A1	7 = TSCA 5e	12 = CA RTK	17 = NJ RTK
3 = ACGIH A2	8 = TSCA 6	13 = IL RTK	18 = PA RTK
4 = OSHA Z	9 = TSCA 12b	14 = LA RTK	19 = RI RTK
5 = TSCA 4	10 = CA P65 CARC	15 = MI 293	

Code key: CARC=Carcinogen; REPRO=Reproductive

#### SECTION 16 OTHER INFORMATION

N/D = Not determined, N/A = Not applicable

**THIS SAFETY DATA SHEET CONTAINS THE FOLLOWING REVISIONS:**



Product Name: MOBIL VACTRA OIL NO. 2  
Revision Date: 17Oct2008  
Page 8 of 8

---

No revision information is available.

---

The information and recommendations contained herein are, to the best of ExxonMobil's knowledge and belief, accurate and reliable as of the date issued. You can contact ExxonMobil to insure that this document is the most current available from ExxonMobil. The information and recommendations are offered for the user's consideration and examination. It is the user's responsibility to satisfy itself that the product is suitable for the intended use. If buyer repackages this product, it is the user's responsibility to insure proper health, safety and other necessary information is included with and/or on the container. Appropriate warnings and safe-handling procedures should be provided to handlers and users. Alteration of this document is strictly prohibited. Except to the extent required by law, republication or retransmission of this document, in whole or in part, is not permitted. The term, "ExxonMobil" is used for convenience, and may include any one or more of ExxonMobil Chemical Company, Exxon Mobil Corporation, or any affiliates in which they directly or indirectly hold any interest.

---

Internal Use Only

MHC: 0B,0B,0,0,0,0

PPEC: A

DGN: 2007221XUS (1014962)

---

Copyright 2002 Exxon Mobil Corporation, All rights reserved