



## **F103/4/5M SERIES**

**MULTI-PURPOSE MANUAL  
MACHINING CENTERS**

**OPERATIONS AND MAINTENANCE  
MANUAL**



**MACHINE SERIAL NUMBER**

---

**MANUFACTURED BY:**

**ROTTLER MANUFACTURING COMPANY**  
8029 South 200th Street  
Kent Washington 98032  
USA

Phone: (253) 872-7050  
Fax: (253) 395-0230  
Website: <http://www.rottlermfg.com>



## MANUAL CONTENTS

<b>Section 1</b>	<b>Introduction</b>
<b>Section 2</b>	<b>Installation</b>
<b>Section 3</b>	<b>Safety</b>
<b>Section 4</b>	<b>Control Definition</b>
<b>Section 5</b>	<b>Operating Instructions</b>
<b>Section 6</b>	<b>Maintenance</b>
<b>Section 7</b>	<b>Troubleshooting</b>
<b>Section 8</b>	<b>Machine Parts</b>
<b>Section 9</b>	<b>Options (located in a separate manual)</b>
<b>Section 10</b>	<b>MSDS</b>

Table of Contents for each section are at the beginning of each section.

## ORDERING PROCEDURE

Contact your regional Rottler sales rep for assistance in ordering optional equipment, replacement parts, or tooling.

If you are unable to contact your regional Rottler sales rep, call the factory at 253-872-7050 and ask to speak to the parts sales specialist.

Have the following information handy to expedite the ordering process:

1. Your name, business name, and contact number
2. Customer number
3. If you don't have a customer number, your billing address
4. Shipping address if different from billing address
5. Machine model and serial number
6. Part number and description of what you want to order
7. Preferred method of shipment

You may also contact us via e-mail with the above information. Send e-mail requests to: [parts@rottermfg.com](mailto:parts@rottermfg.com)

In some cases you may be requested to send a photo of the part you are ordering if it is a replacement part, or doesn't appear in the database.

If you are unsure which part you need to order, contact our service department and ask to speak to one of our service consultants. They will assist you in determining which part you require.

**THERE IS A MINIMUM ORDER OF \$25.00**





# INTRODUCTION

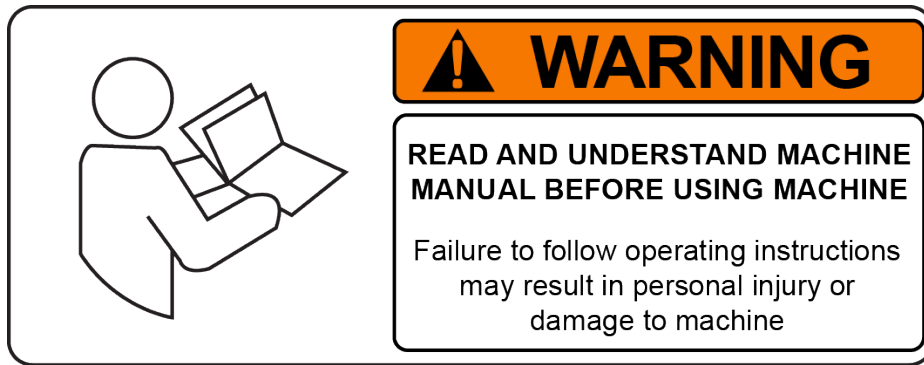

**READ THE SAFETY CHAPTER BEFORE INSTALLING MACHINE. THOROUGHLY UNDERSTAND ALL SAFETY ISSUES BEFORE OPERATING MACHINE.**

## ATTENTION OWNER/BUSINESS MANAGER

**To validate the warranty on your new Rottler machine, please be sure to sign and complete the “Installation Report” located in the Installation Chapter of this manual.**

We suggest that the new user of the F103/4/5M read the CONTROL DEFINITIONS to get an idea how the machine operates.

The Operating Instructions chapter should be read in order to familiarize the user with the actual button pushing sequences required to carry out a job. These chapters in the manual should be considered an introduction. As the operators of the F103/4/5M series machines gain experience with using the different functions of the machine, complicated setups and programs will make more sense.

The rest of the manual contains information and part number reference on fixtures, cutting tools, and machine maintenance. The operator should read and become familiar with these areas as well.

## Description

The model F103/4/5M machine is a precision, single point boring, and high-speed surfacing unit. The machine can be equipped with tooling and accessories for surfacing and re-boring most American passenger car and truck engines, In-lines, as well as 90 and 60 degree V-types.

F103/4/5M machines can be easily tooled, to machine a wide range of engines, including European and Asian engines, also, the machine can be easily adapted to perform other boring and surfacing operations.

The machine is designed, to maintain alignment of cylinder bores, and cylinder head, deck surfaces to the pan rails and main bearing bore locations, as was done in the original factory machining. This overcomes the many inaccuracies and out-of-alignment problems associated with clamping portable boring bars to the cylinder head surface of blocks.

Convenient controls, fast block clamping, precise 3 axis CNC positioning and clamping, means considerable savings in floor to floor time, and operator involvement.

Change over or resetting time required to set up V-type or in-line engines is a minimum, making this machine highly suited to the jobber shop where engines cannot be run through in model lots.

All feeds and rapid travels are power operated and controlled from the control panel.

## Disclaimer

The F103/4/5M Manual (henceforth to be referred to as the "Manual") is proprietary to Rottler Manufacturing LLC. ("Rottler Manufacturing") and no ownership rights are hereby transferred. No part of the Manual shall be used, reproduced, translated, converted, adapted, stored in a retrieval system, communicated or transmitted by any means, for any commercial purpose, including without limitation, sale, resale, license, rental or lease, without the prior express written consent of Rottler Manufacturing. Rottler Manufacturing does not make any representations, warranties or guarantees, express or implied, as to the accuracy or completeness of the Manual. Users must be aware that updates and amendments will be made from time to time to the Manual. It is the user's responsibility to determine whether there have been any such updates or amendments. Neither Rottler Manufacturing nor any of its directors, officers, employees or agents shall not be liable in any manner whatsoever to any person for any loss, damage, injury, liability, cost or expense of any nature, including without limitation incidental, special, direct or consequential damages arising out of or in connection with the use of the Manual.

## Limited Warranty

Rottler Manufacturing Company Model F103/4/5M parts and equipment is warranted as to materials and workmanship. This limited warranty remains in effect for one year from the date of delivery, provided the machine is owned and operated by the original purchaser and is operated and maintained as per the instructions in the manual.

Tools proven to be defective within the warranty period will be repaired or replaced at the factory's option.

The products are warranted upon delivery to conform to their published specifications and to be free from defects in material and workmanship under normal use for a period of one year from shipment. Should a product not be as warranted, Rottler sole obligation shall be, at its option, to repair, correct or replace the product or to refund the amounts paid for the Product upon its return to a location designated by Rottler. No warranty shall extend to rapid wear Products (including tooling) or to Products which have been subject to misuse (including any use contrary to Rottler instructions), neglect, accident (including during shipment), improper handling or installation, or subject to any modification, repair or service not certified by Rottler. Rottler shall not be liable for any consequential, direct or indirect damages or for any other injury or loss. Buyer waives any right, beyond the foregoing warranty, to make a claim against Rottler. No warranty is provided for any products not paid in full.

Merchandise cannot be returned to Rottler without prior approval. Customer must contact the Order Department or representative to get approval and to be issued a Return Goods Authorization number (RGR#). Merchandise authorized for return must be returned prepaid. If merchandise is returned with shipping charges collect, the actual amount of these charges may be deducted from any credit which may be due the customer. The RGR # assigned by the Order Department should be written on the shipping label and must appear on a copy of the invoice(s) covering the original shipment. This invoice copy must be included in the box with the parts. Shipment must contain ONLY those items on the RGR as approved for return. Merchandise must be received within 10 days of the date of RGR or the RGR will be canceled. All returned merchandise may be subject to a 20% restocking fee on under \$1,000.00 amount or 10% on any items over \$1,000.00. Parts or tooling over 30 days old are considered as customer property and can only be returned with prior written approval from Rottler Corporation Management and/or Shipping Department.

***The issuance of a RGR DOES NOT guarantee credit*** - it is only authorization for the return of the goods. Credit for return merchandise is at the sole discretion of Rottler. Credit will be issued only after inspection of returned goods.

Tools proven to be defective within the warranty period will be repaired or replaced at the factory's option. We accept no responsibility for defects caused by external damage, wear, abuse, or misuse, nor do we accept any obligation to provide compensation for direct or indirect costs in connection with cases covered by the warranty.

This page intentionally left blank

# INSTALLATION

## Contents

<b>ROTTLER F100 SERIES INSTALLATION REPORT .....</b>	<b>2-2</b>
<b>Removing Machine from Shipping Container.....</b>	<b>2-8</b>
<b>Installation Procedure.....</b>	<b>2-9</b>
<b>Rottler F103/4/5 Series Foundation and Hold Down Requirements .....</b>	<b>2-9</b>
<b>F105M Hold Down and Jacking Bolt Locations.....</b>	<b>2-10</b>
<b>F104M Hold-down / Jacking Bolt Locations .....</b>	<b>2-11</b>
<b>F103M Hold-down / Jacking Bolt Locations .....</b>	<b>2-12</b>
<b>Machine Dimensions.....</b>	<b>2-13</b>
<b>Location .....</b>	<b>2-14</b>
<b>Unpacking.....</b>	<b>2-14</b>
<b>Column Hold Down.....</b>	<b>2-14</b>
<b>Leveling .....</b>	<b>2-14</b>
<b>Air Supply.....</b>	<b>2-15</b>
<b>Power Supply.....</b>	<b>2-16</b>
<b>Grounding.....</b>	<b>2-16</b>

## **ATTENTION OWNER/BUSINESS MANAGER**

**To validate the warranty on your new Rottler machine, please be sure to sign the installation report after the installation technician has installed the machine and verified the machine is operating correctly and given the operators operation and maintenance training.**

**Thank you for your cooperation and the opportunity to be of service to you.**

***ROTTLER MANUFACTURING***

Route to: John Fisher → Andy → Machine Packet File  
F100 Installation Report Rev 04162015

**ROTTLER F100 SERIES INSTALLATION REPORT**

**ROTTLER MANUFACTURING MUST HAVE THIS REPORT RETURNED TO PROPERLY QUALIFY WARRANTY ON EQUIPMENT**

Customer: \_\_\_\_\_ Address: \_\_\_\_\_  
City: \_\_\_\_\_ State: \_\_\_\_\_ Zip: \_\_\_\_\_ Phone: \_\_\_\_\_  
Machine Model: \_\_\_\_\_ Serial Number: \_\_\_\_\_ Representative: \_\_\_\_\_

**MACHINE INSTALLATION:** Electrical information MUST be complete to validate this report.

\_\_\_\_\_ Customer has read and fully understands importance of machine location as explained in the installation section of the manual.

**The following is the customer’s responsibility prior to the arrival of Rottler technician. Please initial each item when it is completed.**

Customer must provide foundation and hold down bolt system, see following attached drawing and document “F70 and F100 Series Foundation and Hold Down Requirements”



**VERY IMPORTANT:** Modern design machines contain electronic low voltage circuitry that provides great advantages and a better machine life. **BUT**, you must have an excellent, stable, isolated power supply along with an isolated ground. If not, electrical noise problems are likely to interfere with machine operation unexpectedly.

Customer is responsible for providing electricity to machine in a manner that meets the local electrical code requirements.

- \_\_\_\_\_ Remove machine from truck. Weight: F103 14,000 lbs (6,350 kg) F104 16,000 lbs (7257 kg) F105 18,000 lbs (8165 kg) F107 45,000 lbs (20,412 kg) F109 50,000 lbs (22680 kg).
- \_\_\_\_\_ Remove fixturing and misc. parts from machine and clean.
- \_\_\_\_\_ Install machine on foundation with supplied jack pads under jacking bolts.
- \_\_\_\_\_ Install hold down nuts and bolts, see attached document. – This must e done first.
- \_\_\_\_\_ Rough Level the machine using a precision level so there is equal tension on all bolts.
- \_\_\_\_\_ This machine requires between 208 and 240 Volts AC, Three Phase, 50/60 Hz, isolated power supply. For voltages above 240 or below 208 VAC, a 17kva transformer will be required and is available at Rottler. Please specify voltage when ordering. Measure the incoming voltage between L1 and L2, L2 and L3, and L1 and L3. Current requirements for this machine is 60 amps. Measure the incoming AC voltage at least twice during installation.
  1. L1to L2 \_\_\_\_\_ VAC, L2 to L3 \_\_\_\_\_ VAC, L1 to L3 \_\_\_\_\_
  2. L1to L2 \_\_\_\_\_ VAC, L2 to L3 \_\_\_\_\_ VAC, L1 to L3 \_\_\_\_\_
- \_\_\_\_\_ Measure each leg of the incoming supply to ground. Sometimes you may find a “high” leg to ground. When this happens make sure the high leg is running to L3. This line goes to the spindle drive only.  
L1 to ground \_\_\_\_\_ VAC L2 to ground \_\_\_\_\_ VAC L3 to ground \_\_\_\_\_ VAC

**CAUTION**

Neutral and machine ground are not the same thing. You should measure an open circuit between Neutral and ground.

**CAUTION**

**IF VOLTAGE IS OUTSIDE THE CORRECT RANGE AT ANY TIME THE MACHINE WILL NOT OPERATE PROPERLY AND MAY BE DAMAGED.**

- \_\_\_\_\_ Air of the proper pressure and capacity connected to the machine. Air supply must be free from oil and water. Oil or water will damage electrical and air components.
- \_\_\_\_\_ Customer should attempt to have junk work piece available.
- \_\_\_\_\_ Have the operator read through the operation manual before training begins. This will help him be familiar with the button pushing sequences. Have the operator read through the manual again after training and some of the sequences will make more sense.
- \_\_\_\_\_ Have Internet connection available for the machine. Either via Ethernet cable or Wireless. The machine comes equipped with a wireless USB adapter.

## The following is the Rottler technician's responsibility

- \_\_\_\_\_ Check column top and spindle base bottom for rust and nicks if spindle must be installed. Clean and stone as required.
- \_\_\_\_\_ When lifting spindle unit, keep in mind the front to back center of gravity is located approximately 12 inches from the front end and has a tendency to lean forward.
- \_\_\_\_\_ Each main system is protected internally by circuit breakers. Green indicates the breaker is "tripped" and red indicates the breaker is "Hot" (conducting electricity).
- \_\_\_\_\_ Clean any rust inhibitor from the machine surfaces. Move the column from side to side continually cleaning the machine base until all inhibitor is removed.
- \_\_\_\_\_ Install spindle unit on column, if required, using one of the approved methods described in the operation manual. (Spindle unit weighs 6,000 lbs, 2,800 Kgs.)

### Using fork lift angle iron brackets

- \_\_\_\_\_ Bolt brackets to each side of the spindle base.
- \_\_\_\_\_ Use large C-clamps to clamp the fork lift forks to the angle iron brackets. This will prevent any accidental slips. Loosen 1/2 13 x 3 1/2 Inch bolts on pendent arm to allow it to be moved out of the way.
- \_\_\_\_\_ Use a forklift to lift the spindle unit onto the column. Be careful to watch clearance of all items.
- \_\_\_\_\_ Install the Right (Fixed Side Rail) and removable dowel pins. Torque Side Rail bolts to 80 Ft/lbs.
- \_\_\_\_\_ Lift spindle unit into place. Push spindle base up against Right Side Rail.
- \_\_\_\_\_ Install left side rail (9202A) with 2 Belleville's (9024E) opposing each other ( ) on each set screw (9202D), set rail .065" - .075" above spindle base. Torque Side Rail bolts to 80 Ft/lbs.
- \_\_\_\_\_ Adjust the adjustable screws (9202D) on SIDE rails by tightening them until they bottom out, then unscrewing them 1/8 turn.
- \_\_\_\_\_ Measure the protrusion of the Sides Rails above the spindle base and record. These should be between .060" and .070"
 

Right:	Front _____	Rear _____
Left:	Front _____	Rear _____
- \_\_\_\_\_ Install the Right and Left Top Rails.
- \_\_\_\_\_ Install top rails (9202B) with 2 Belleville's opposing each other ( ) on each adjustable set screw (9202D). Torque to 80 lbs.
- \_\_\_\_\_ Adjust the adjustable screws (9202D) on TOP rails by tightening them until they bottom out, then unscrewing them 3/4 turn.
- \_\_\_\_\_ Remove angle iron brackets from spindle base.
- \_\_\_\_\_ Connect air and oil lines per air logic diagram.
- \_\_\_\_\_ Remind customer of the proper air pressure and capacity connected to the machine. Air supply must be free from oil and water. Oil or water will damage electrical and air components.
- \_\_\_\_\_ Connect electrical wires in main rear enclosure if required using machine wiring diagram.



**MACHINE START-UP**

When starting the machine for the first time, it may move out of control. Make sure all hands are clear of machine parts. Be ready to press the Emergency Stop button if needed.

- \_\_\_\_\_ **BEFORE** turning power on to the machine. Check all wires for security by using the correct screw driver and turning CW until movement stops. Stranded wire can “spread” slightly from vibration during transport.
- \_\_\_\_\_ Turn main power on at the main disconnect switch located on the rear enclosure.
- \_\_\_\_\_ If machine moves out of control, turn power off and contact factory for help in trouble shooting.
- \_\_\_\_\_ If any of the circuit breakers “trip”, reset and call factory for possible trouble shooting.
- \_\_\_\_\_ Install and test the internet connection to the machine. DO NOT download any updates unless instructed to do so by Rottler.

**MACHINE MOVEMENTS**

- \_\_\_\_\_ Make sure there is nothing obstructing the full vertical, horizontal or In/Out travel of the machine taking special notice of the rear enclosure, way travel and top of the spindle unit.
- \_\_\_\_\_ Put the machine in hand wheel mode and verify Vertical operation. Put an indicator on the cutter head and verify .001” movement per detent in course mode and .0001” in fine mode. If the indicator is jumpy the outer spindle adjustment may be too tight. Refer to manual and re-adjust.
- \_\_\_\_\_ Put the machine in hand wheel mode and verify Horizontal operation. Put an indicator on the cutter head and verify .001” movement per detent in course mode and .0001” in fine mode
- \_\_\_\_\_ Use the rapid buttons and verify proper vertical, horizontal and In/out travel.
- \_\_\_\_\_ Check limit switch operation with handwheel before using the power feed.
- \_\_\_\_\_ Move the machine to its vertical limits to verify proper operation.
- \_\_\_\_\_ Move the machine to its horizontal limits to verify proper operation.
- \_\_\_\_\_ Move the machine to its In/Out limits to verify proper operation.
- \_\_\_\_\_ Start the spindle and verify operation at all speeds.
- \_\_\_\_\_ Use the spindle creep buttons and verify proper operation.
- \_\_\_\_\_ Prime the oiling system. (See maintenance section of manual for complete details.)
- \_\_\_\_\_ Use a precision level and level the machine:

Record machine level readings below (must be within .0005). Back Way:

Back Way:

P1 \_\_\_\_\_ P2 \_\_\_\_\_ P3 \_\_\_\_\_ P4 \_\_\_\_\_ P5 \_\_\_\_\_ P6 \_\_\_\_\_ P7 \_\_\_\_\_ P8 \_\_\_\_\_

Back to Front Way:

P1 \_\_\_\_\_ P2 \_\_\_\_\_ P3 \_\_\_\_\_ P4 \_\_\_\_\_ P5 \_\_\_\_\_ P6 \_\_\_\_\_ P7 \_\_\_\_\_ P8 \_\_\_\_\_

Record Dial Indicator readings:

Spindle to Back Table:

P1 \_\_\_\_\_ P2 \_\_\_\_\_ P3 \_\_\_\_\_ P4 \_\_\_\_\_ P5 \_\_\_\_\_ P6 \_\_\_\_\_ P7 \_\_\_\_\_ P8 \_\_\_\_\_

Spindle to Front Table:

P1 \_\_\_\_\_ P2 \_\_\_\_\_ P3 \_\_\_\_\_ P4 \_\_\_\_\_ P5 \_\_\_\_\_ P6 \_\_\_\_\_ P7 \_\_\_\_\_ P8 \_\_\_\_\_

\_\_\_\_\_ Check mill tilt, and lift amounts with Y axis in the middle of travel, and record  
Amount of tilt \_\_\_\_\_

**The following procedures should be shown to personal involved in machine maintenance.**

See maintenance section of manual for complete details.

\_\_\_\_\_ Check, and adjust X axis gibs

\_\_\_\_\_ Adjust outer spindle bushings.

\_\_\_\_\_ Adjust inner spindle bearings

\_\_\_\_\_ Perform spindle sweep adjustment.

\_\_\_\_\_ Verify ALL axis backlash comp is operating properly, adjust if needed. Record actual readings after verification.

	Auto	Handwheel
X-Axis	_____	_____
Y-Axis	_____	_____
Z-Axis	_____	_____

\_\_\_\_\_ Install way cover brackets and way covers. Way Cover support brackets should be flush with way surface.

## INSTRUCTING THE OPERATOR

### **WARNING**

\_\_\_\_\_ Explain to the customer and operator that at NO time is there to be any software or hardware other than Windows Auto Update and Rottler installed on this machine. This includes screen savers, anti-virus software, and any hardware device that installs software on the machine. Installation of screen savers and anti-virus software can cause dangerous control problems. Any installation of software or hardware will void the warranty on the machine.

\_\_\_\_\_ Explain to the customer and operator that the machine should be hooked up to the internet anytime it is on. The software on the machine will automatically connect to our server to send back useful information on machine status.

\_\_\_\_\_ Explain to the customer and operator that the Auto Update for the Windows Firewall (Security) and Windows Defender (Anti-Virus) is turned on. The computer will automatically download the updates and then install them when the computer is shut down every Friday night.

\_\_\_\_\_ Explain to the customer and the operator how the to log onto Skype and communicate with Rottler when needed.

### **WARNING**

\_\_\_\_\_ Computer Viruses will cause the machine control system to become unstable. This may cause the machine to make uncontrolled moves which could create a dangerous environment for the machine operator.

\_\_\_\_\_ Connect customer supplied Internet to the machine. Verify that the Internet is accessible from the machine.

## IMPORTANT

\_\_\_\_\_ Refer to Chapter 4, Control Definitions of the Machine Manual, Section: Computer and Controller System Safety. Explain and discuss this section carefully with Owner/Manager/Operator and have them sign off. Failure to do so will result in the machine warranty being Null and Void.

---

Signature / Title

\_\_\_\_\_ Explain to the customer the proper way to turn the machine off when it is not in use. Do not leave the machine on overnight. It is important to close all programs followed by shutting down Windows before turning the main power switch off. Do not turn the main power switch off before shutting down Windows.

\_\_\_\_\_ Using the operating manual as a guide explain the function of all buttons.

\_\_\_\_\_ Cycle all machine movements and supervise the handling of same by operator.

\_\_\_\_\_ Demonstrate the differences of Manual and Auto operation.

\_\_\_\_\_ Fully explain the entire Auto Cycle from Centering to Auto Retract.

\_\_\_\_\_ Explain machine parameters and error messages. It is very important that the customer does not change parameter settings without first checking with Rottler Manufacturing. If certain parameters are changed the machine may make uncontrolled moves or not operate at all.

\_\_\_\_\_ Point out safety features to customer and operator. Do not push any buttons without thinking of safety first.

 **CAUTION** Do not assume the cutterhead micrometer has been calibrated.

\_\_\_\_\_ Install a work piece in the machine and perform an undersize test bore to qualify the micrometer setting to the customers measuring tools.

Note adjustments: + \_\_\_\_\_, - \_\_\_\_\_.

\_\_\_\_\_ Explain precision reset of tool in cutterhead.

\_\_\_\_\_ The following is a checklist to go through every time the machine is started to begin a cut or automatic cycle.

- Work piece secure
- RPM set
- Feed Rate set
- Correct program in use
- Program oriented correctly (vertical zero at correct place) Centering range adequate
- Guards in place
- Cutterhead secure
- Tool holder adjusted to the correct size
- Tool holder locked in place

\_\_\_\_\_ Proceed to have operator bore block to size.

\_\_\_\_\_ Demonstrate and explain boring with the electronic hand wheel.

\_\_\_\_\_ Explain the correct Feed rates and speeds from Cutting Insert Bulletin.

\_\_\_\_\_ Cutter head change and expected stub bar performance.

\_\_\_\_\_ Parts ordering, refer the to the operating manual for part numbers and description.

\_\_\_\_\_ Offset tool bits, calibration of micrometer and anvil setting.

\_\_\_\_\_ Train on ALL Rottler programs even if they need to be run in the air.

\_\_\_\_\_ If Rottler CAM was provided to the customer train on any programs supplied by Rottler.

\_\_\_\_\_ Review Emergency stop procedure with operator per operating manual.

**MAINTENANCE SECTION**

- Use the manual as a reference when explaining routine maintenance and lubrication.
- Overload devices, There are no mechanical overload devices on this machine. The machine is protected from overload by the motor controllers. If the system is overloaded the controllers shut the motors off. The controllers can be reset by turning the main power off for at least 1 minute, then turning it back on.
- Explain again the proper Inner and Outer spindle adjustment to the operator.
- Air float adjustment.
- Dampener cleaning.
- Micrometer and anvil thread adjustment.
- Inspection of tool bit hole in tool holders (deformation due to accidental impact).

General remarks on machine performance, adjustments as received and any further organization or parts required to complete the set up:

---



---



---



---



---



---



---



---



---



---



---



---



---



---



---



---

Instructions given to: \_\_\_\_\_

Sales/Service Engineer: \_\_\_\_\_ Date \_\_\_\_\_

Shop Foreman/Superintendent or Owner: \_\_\_\_\_ Date \_\_\_\_\_

## Removing Machine from Shipping Container

As of this date forward all F79 and F100 series machines shipped in containers will have pulling straps to help in the removal of the machine from the shipping container.

Once all lagging bolts and wedge blocks have been removed, the machines can be partially pulled out from the container using the preinstalled straps to make lifting easier.

Rottler recommends that a professional material handling business that is bonded and insured be contracted for unloading machines from containers.

Below is an example of the pull straps that will be sent with machines shipped in containers.

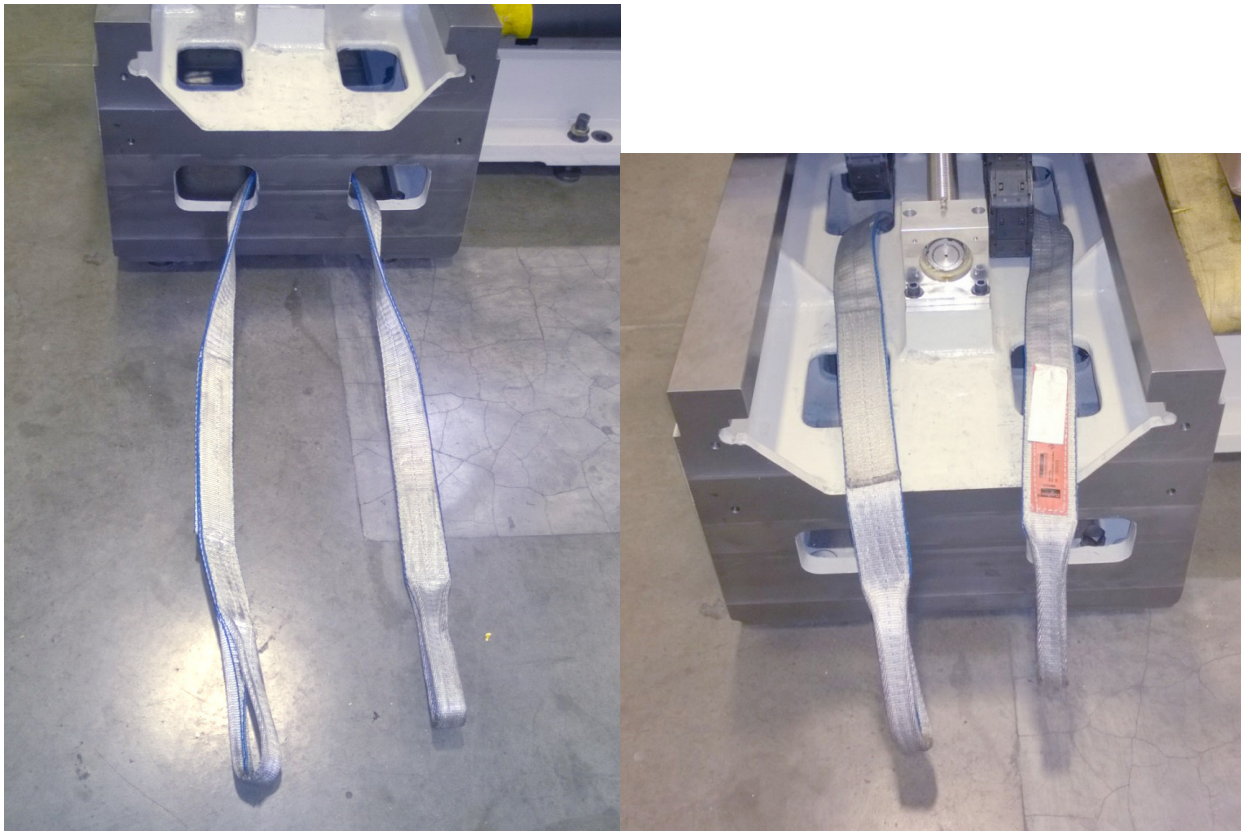

## Installation Procedure

### Rottler F103/4/5 Series Foundation and Hold Down Requirements

Rottler machines require a good concrete foundation and hold down system. It is not recommended to install a machine on a cracked floor or over an expansion joint. The layout/position of the hold down holes can be found on the foundation drawings below.

There are two methods commonly used by customers:

1. Drill the concrete floor as per drawing layout before arrival of machine.
2. Place machine, mark floor through holes in machine base, move machine away then drill the floor.

The machine is provided with jacking bolts and steel pads to place between the jacking bolts and floor. For shipping, the steel pads are packed in a separate box and marked with yellow/black tape so the box is clearly visible. This allows the machine to be unpacked and removed from the shipping crate, placed on the floor on these steel pads without opening the accessory crates. When placing the machine on the jacking bolts, ALWAYS rough level to be sure that the weight of the machine is evenly distributed over all the jacking bolts.

Rottler recommend Hilti products as per attached list. 3/4" (20mm) diameter X 12" (300mm) long studs are recommended. Drill floor approx 7" (180mm) deep with 1" (25mm) drill. As it is difficult to drill concrete exactly on center, it is recommended to drill a pilot hole. After drilling and before injecting epoxy, it is also recommended to move the machine into place and make sure all studs fit through the holes in the base and travel all the way down into the holes so that approx 5" (130mm) protrude out of the floor. The machine may have to be moved a small amount to allow all studs to fit. Once this is checked, the studs can be removed then the epoxy injected into the bottom of the holes. Make sure all dust is vacuumed out of the holes before the epoxy is injected. Ensure that the epoxy is injected starting at the bottom of the holes to be sure the stud has maximum contact with the epoxy. The size of the holes will determine how much epoxy to inject into the holes before fitting the studs. On average, 1/2 to 2/3 of the hole should be filled with epoxy before the stud is installed. Be sure when the stud is installed, that the epoxy fills the hole to the top. Fit the washer and nut and tighten lightly to align the stud then allow the epoxy 24 hours to harden ready for leveling and final anchoring.

The column is tied down with chains for transport, if it is required to move the column to help with installation of the hold down system, the column tie downs can be removed and manually turn the horizontal ball screw nut by hand to move the column sideways. Be sure that the slideways are clean and lubed under the column before moving.

### F105M Hold Down and Jacking Bolt Locations

A scalable version of this drawing is located on the manual CD.

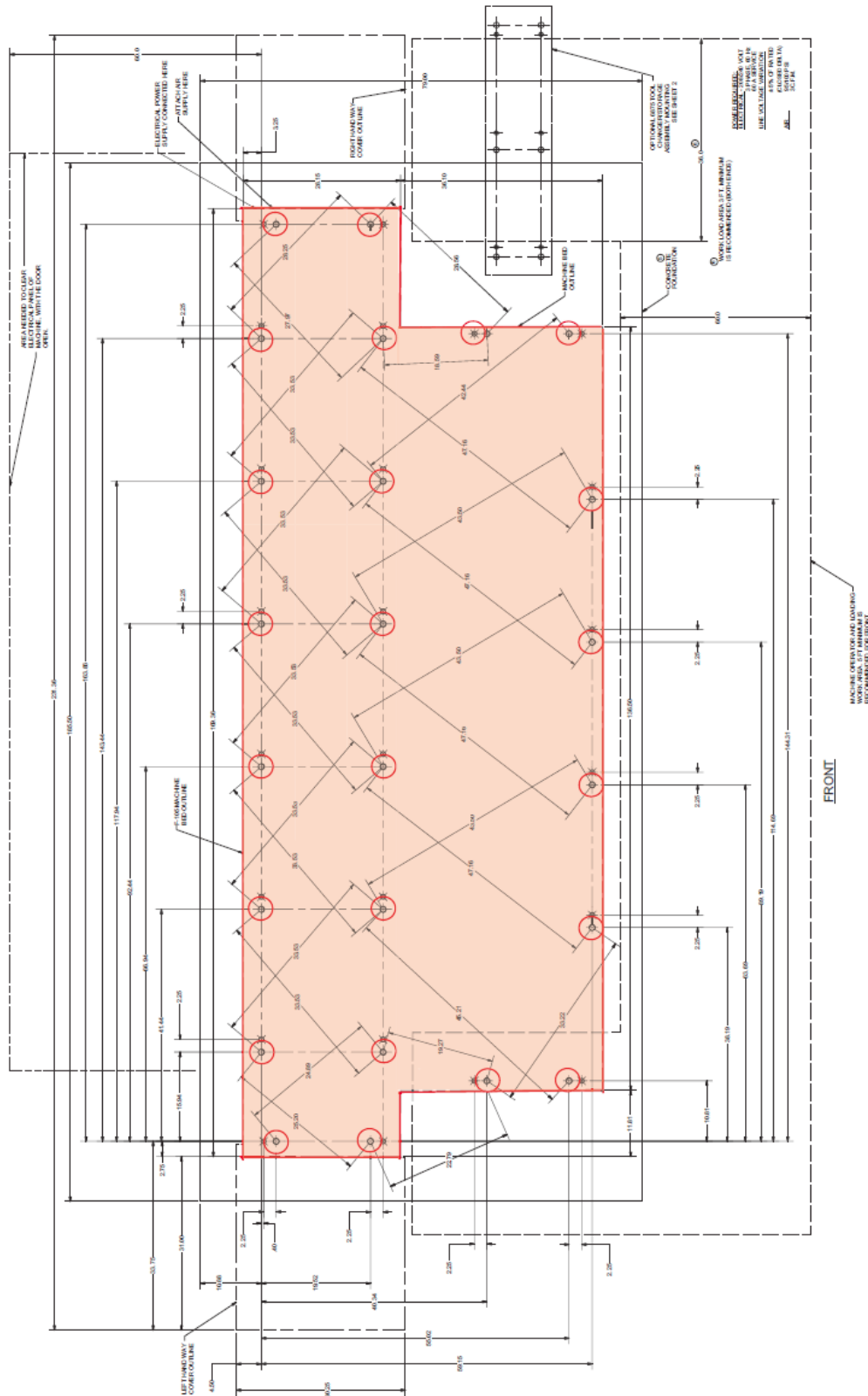



### F104M Hold-down / Jacking Bolt Locations

A scalable version of this drawing is located on the manual CD.

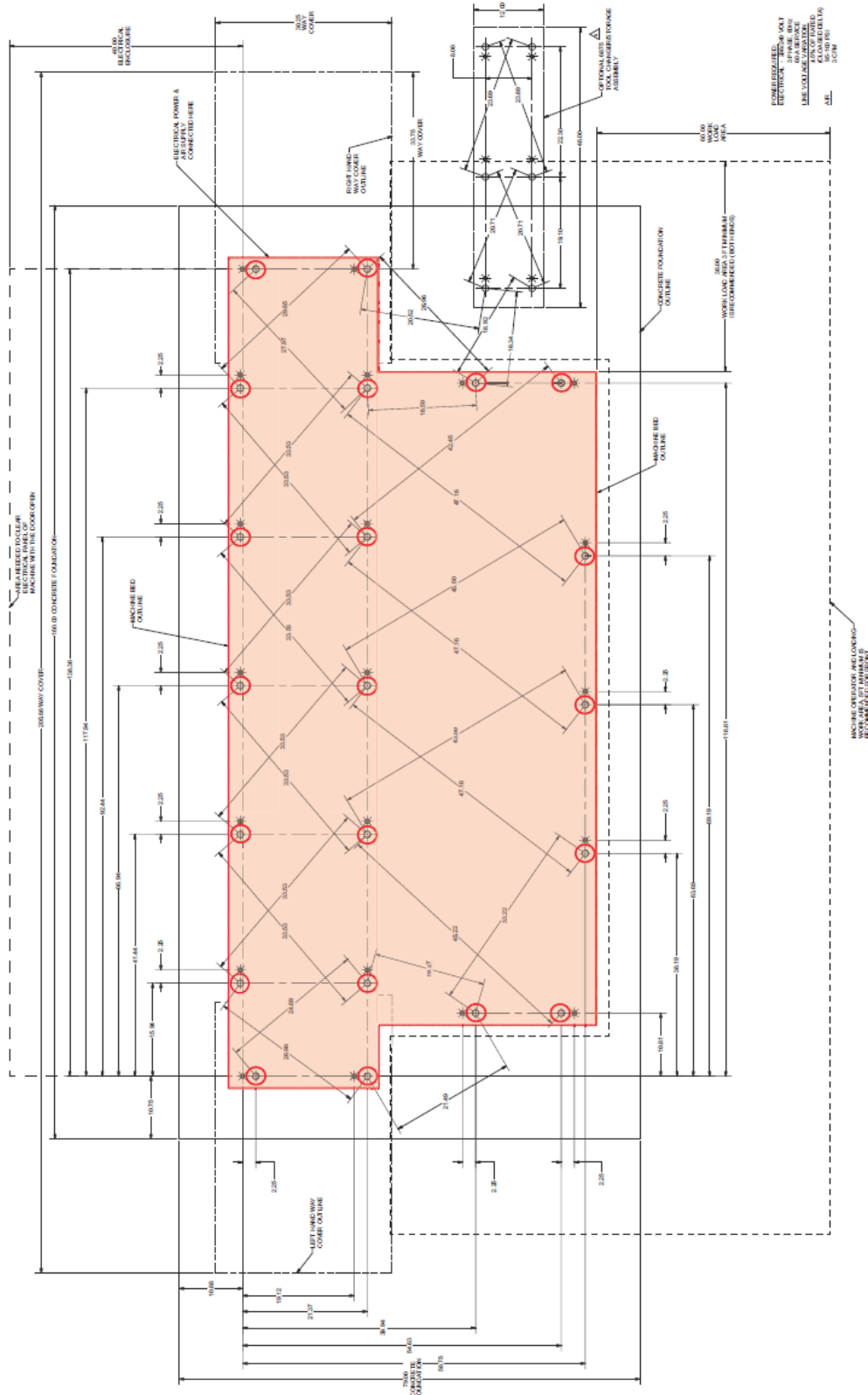



# F103M Hold-down / Jacking Bolt Locations

A scalable version of this drawing is located on the manual CD.

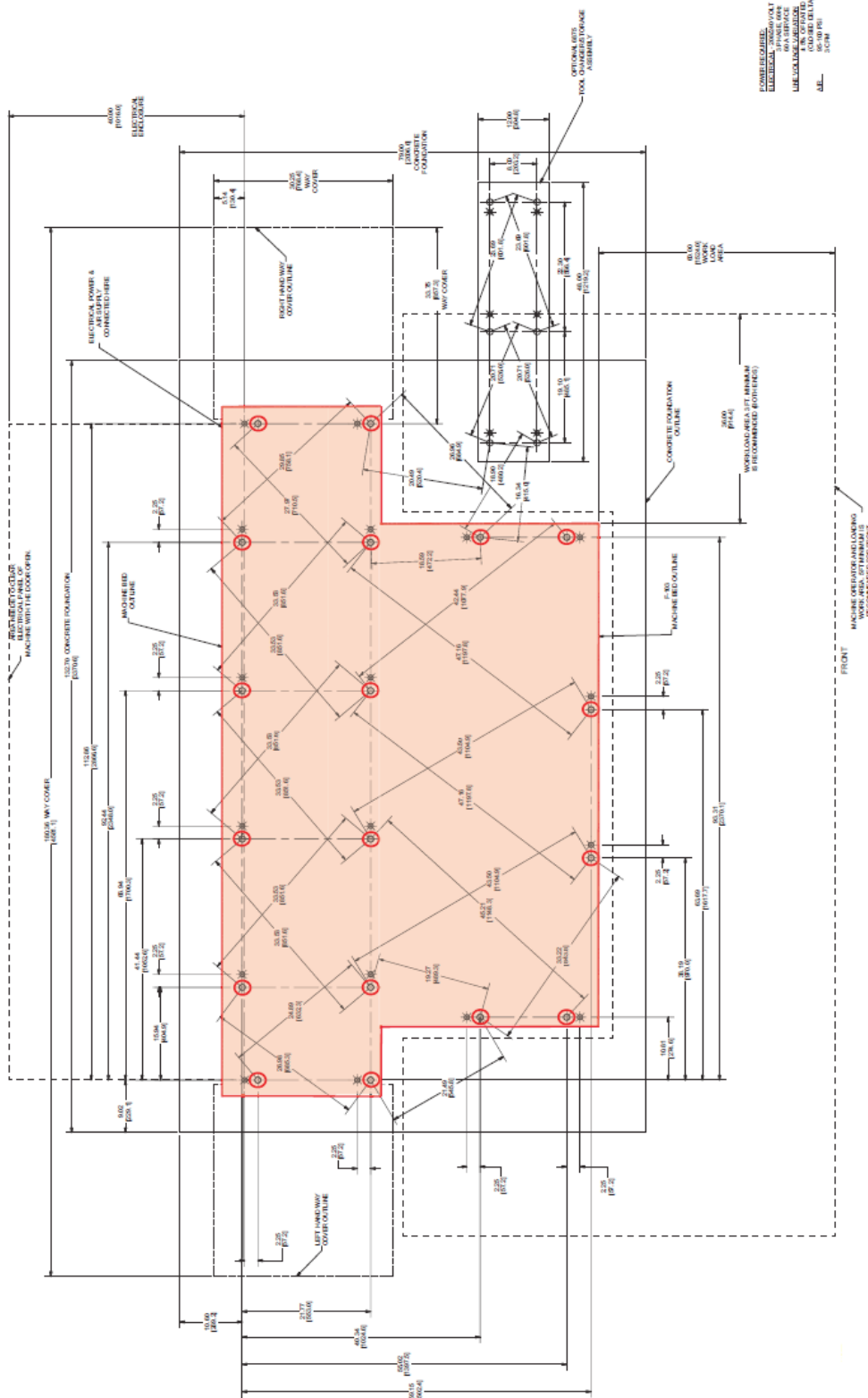

### Machine Dimensions

#### Left Side View

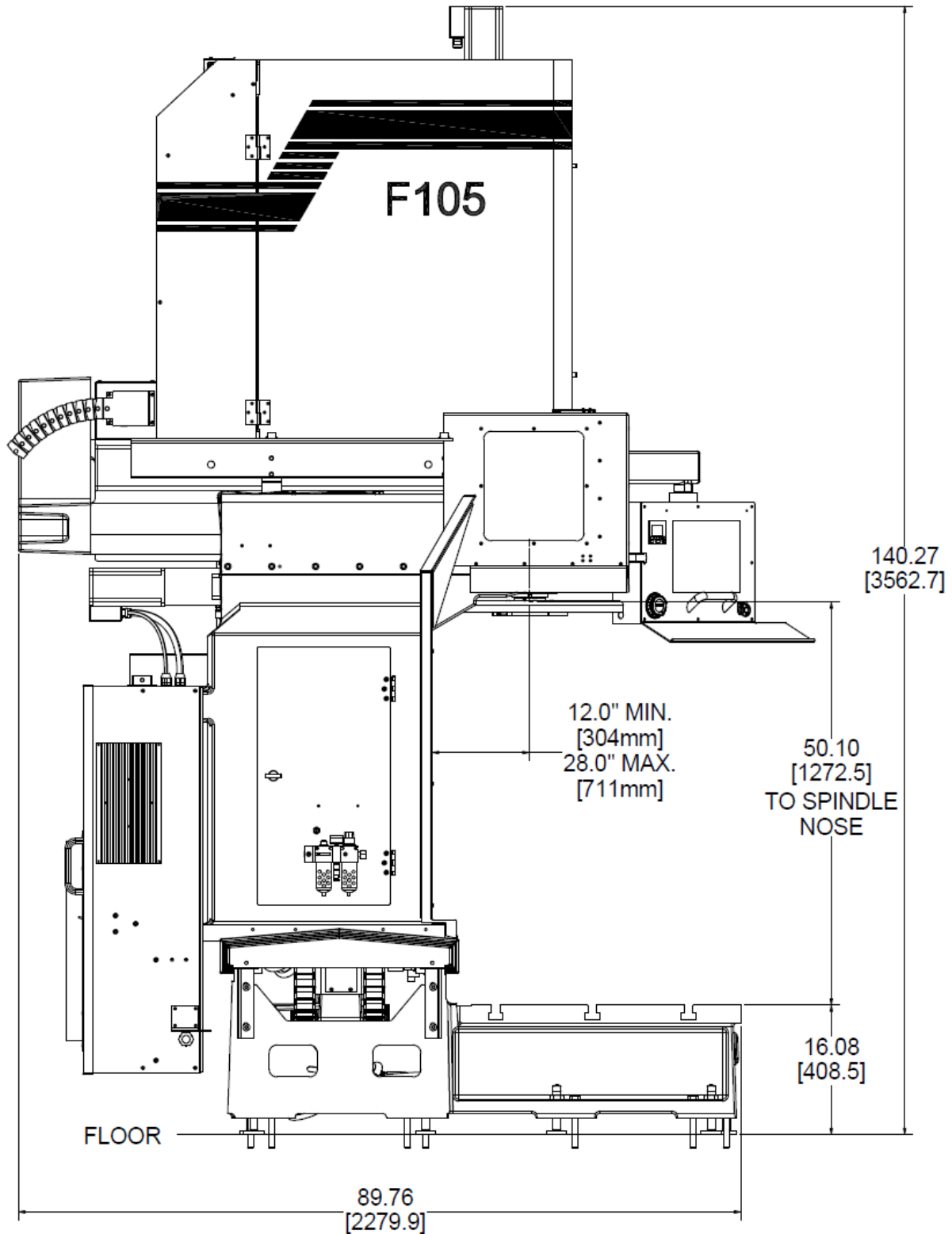

**IMPORTANT! Placement of Machine**

It is critical that the machine be placed in an area of the facility that has a stable thermal environment. The machine should be kept away from direct sunlight, large heating units, and doorways that would allow outside air direct contact on the machine.

Exposure to the above and other extremes in temperature will cause thermal drift to occur in the machines which could have a detrimental effect on machining accuracy. A number of unrepeatability errors in machine performance have been linked to this condition.

**Location**

The productivity of this machine will depend a great deal on its proper initial installation. Pay particular attention to the means by which work pieces are lifted into the machine as well as the material handling to and from other operations in your shop.

The proper loading arrangement and area location for your F103/4/5M machine is extremely important.

A slow travel (6' to 10' per minute) power hoist, operated from either a bridge crane or a jib crane arrangement works very well. Verify the hoist has a rating that exceeds the load being lifted.

For the shop where large production runs are anticipated, the work pieces should be directly loaded and unloaded from a conveyor. If this is not the case we recommend considerable attention be given to the crane so that it covers an adequate area, to allow the operator to back up and remove work pieces without creating a dangerous, cluttered work area.

**Unpacking**

Use care in removing the crate materials from the machine. Be careful not to use force on any part of the machine.

Remove the toolbox, parallels and optional equipment from the machine. Completely clean these articles as well as the rest of the machine with solvent. Rust inhibitor was applied, at the time of shipment. Any of this left on the machine, will allow cast iron dust to collect in that area, which could cause premature wear.

**Column Hold Down**

The machine was shipped with the column held in place with chains and turnbuckles to the Main bed. Do not attempt to move the machine under power until these restraints have been removed.

**Leveling**

Located in the bottom of the main base are the leveling and tie down screws. If care is taken, the main base can be leveled extremely accurately. Start by placing the jacking pads under the jacking screws. Adjust the jacking screws so the lowest point of the main base is at least 1/4" off the jacking pad. Make sure all the jacking screws are touching their jacking pads. Use a precision machinist's level, and check the base at several points to get an idea where the high and low spots are, adjust evenly where necessary. Start with the back way surface. With your precision level, level the back way in the lengthwise direction to .0005" per foot. Take the readings approximately mid way between the jacking points.

Use a precision metal support to span the distance between the front and rear parallels. (Support must be parallel within .0005" in its length). Take readings over every jacking bolt and level within .0005" over the length of the base. Be sure to use the jacking points down the middle of the main base.

Recheck the way surfaces for level. Now check the machine table. Using the front jacking screws level the table within .0005" in both directions.

Be sure that all jacking bolts have approximately equal weight on them. As you go leveling the base snug the tie down bolts to help hold the main base in place. Recheck all areas of the main base for level.

## Air Supply

It is very important the air source for the F103/4/5M machine be moisture free. Water and oil in the line will result in early cylinder and valve failure. The factory recommends installing a water trap at the machine.

Attach a 100 PSI air source to the appropriate intake in the small enclosure located on the left rear of the machine near the bottom.

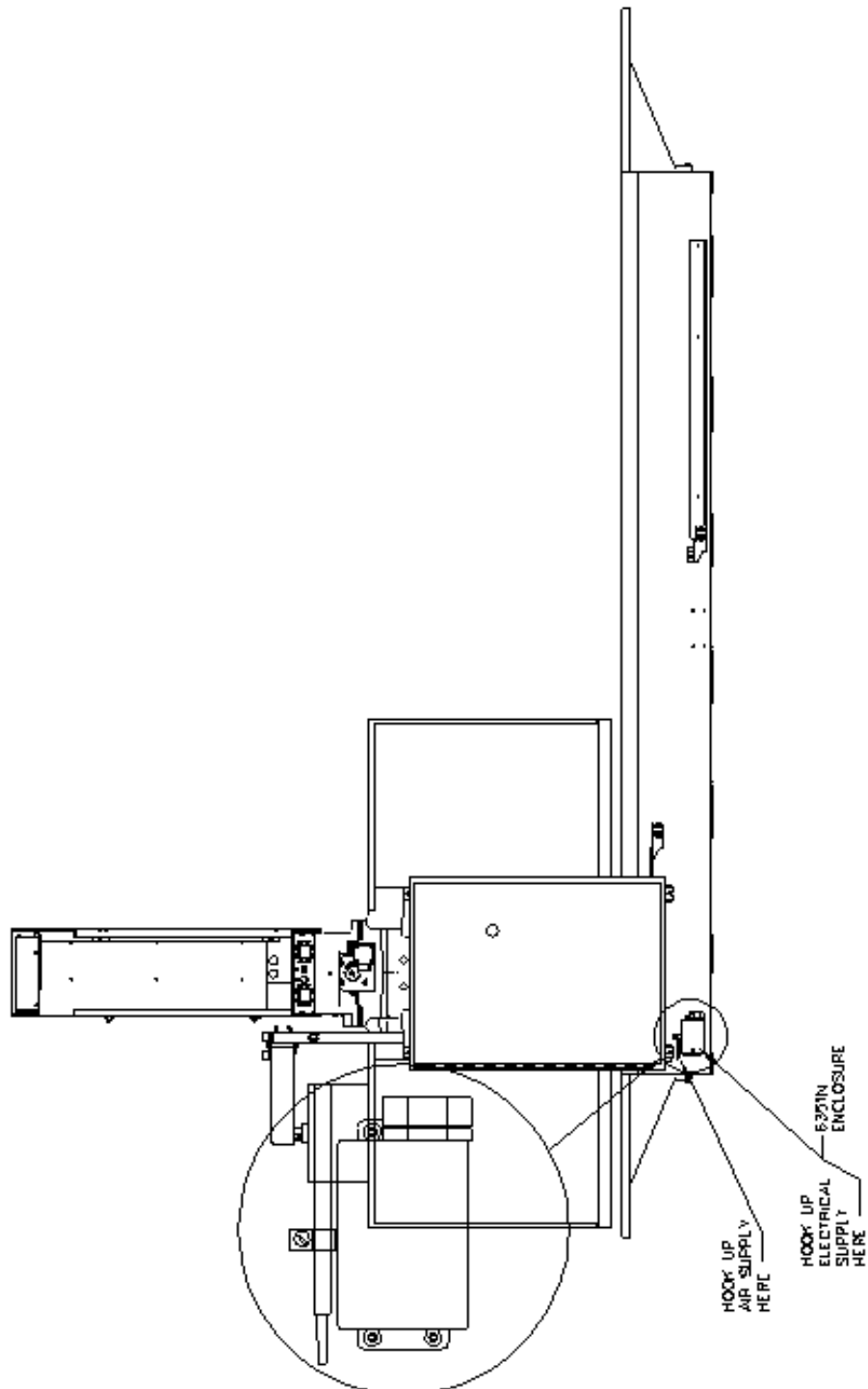

## Power Supply

This machine has the following power requirements:

208 to 240 VAC

Three Phase

50 or 60 Hertz

60 amps

See illustration below for correct connection of “measured” incoming power. Connect three phase wiring to the electrical box located on the back of the machine in the lower right hand corner. See illustration below. If a “high leg” exists, this must be at Line 3. All ground wires go to ground block. Important:

**Electrically connect in accordance with national and local electrical codes.**

**Note: For voltages over 240 VAC (380 – 440 VAC) a factory supplied transformer needs to be purchased with the machine.**

## Grounding

This machine must be connected to a good earth ground rod. A 6 foot, 1/2” diameter, 15 OHM, Copper grounding rod driven into the earth next to the machines is preferred. Not providing a grounding rod could void factory warranty.

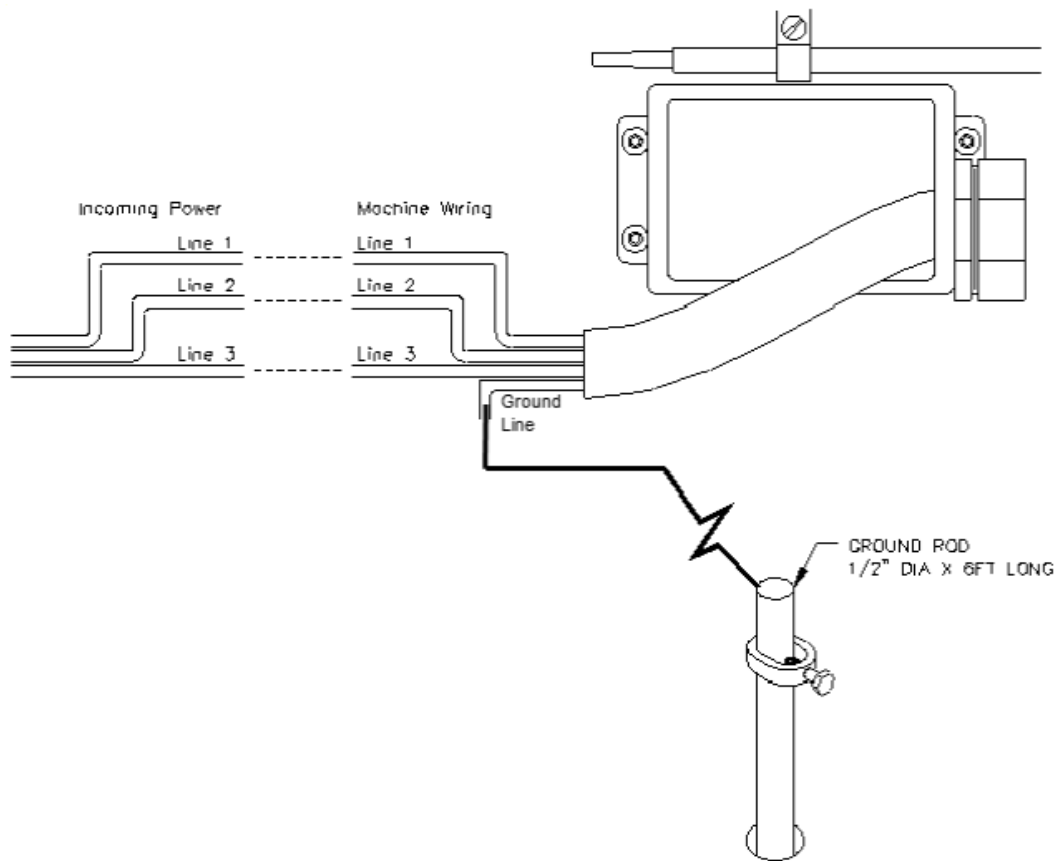

This page intentionally left blank

# **SAFETY**

## **Contents**

<b>Safety Information .....</b>	<b>3-1</b>
<b>Safety Instructions for Machine Use .....</b>	<b>3-1</b>
<b>Electrical Power .....</b>	<b>3-3</b>
<b>Machine Operator .....</b>	<b>3-5</b>
<b>Emergency Procedure .....</b>	<b>3-6</b>
<b>Computer and Controller System Safety .....</b>	<b>3-6</b>

## Safety Information

For Your Own Safety Read This Instruction Manual Before Operating This Machine.

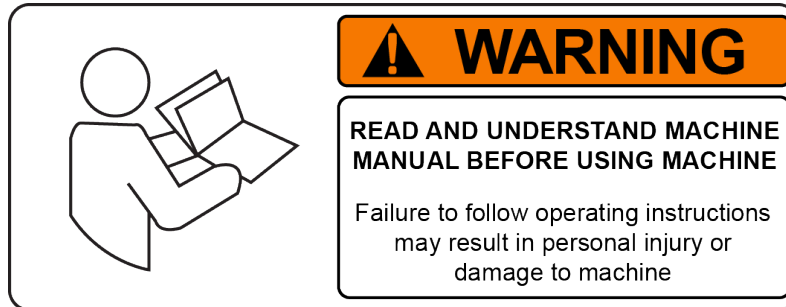

This is the safety alert symbol. It is used to alert you to potential personal injury hazards. Obey all safety messages that follow this symbol to avoid possible injury or death.



**DANGER** indicates an imminently hazardous situation which, if not avoided, will result in death or serious injury.



**WARNING** indicates a potentially hazardous situation which, if not avoided, could result in death or serious injury.



**CAUTION** indicates a potentially hazardous situation which, if not avoided, may result in minor or moderate injury.



**CAUTION** used without the safety alert symbol indicates a potentially hazardous situation which, if not avoided, may result in property damage.

### Safety Instructions for Machine Use



This machine is capable of causing severe bodily injury

**ONLY A QUALIFIED, EXPERIENCED OPERATOR SHOULD OPERATE THIS MACHINE. NEVER ALLOW UNSUPERVISED OR UNTRAINED PERSONNEL TO OPERATE THE MACHINE.** Make sure any instructions you give in regards to machine operation are approved, correct, safe, and clearly understood. Untrained personnel present a hazard to themselves and the machine. Improper operation will void the warranty.

**KEEP GUARDS IN PLACE** and in proper working order. If equipped with doors, they must be in the closed position when the machine is in operation.



**KEEP WORK AREA CLEAN.** Cluttered areas and benches invite accidents.



**KEEP CHILDREN AND VISITORS AWAY.** All children and visitors should be kept a safe distance from work area.

**WEAR THE PROPER APPAREL.** **DO NOT** wear loose clothing, gloves, rings, bracelets, or other jewelry which may get caught in moving parts. Non-Slip foot wear is recommended. Wear protective hair covering to contain long hair.

**ALWAYS USE SAFETY GLASSES.** Also use face or dust mask if cutting operation is dusty. Everyday eye glasses only have impact resistant lenses, they are NOT safety glasses.



**DO NOT OVER-REACH.** Keep proper footing and balance at all times.

**USE THE RECOMMENDED ACCESSORIES.** Consult the manual for recommended accessories. The use of improper accessories may cause risk of injury.

**CHECK DAMAGED PARTS.** Before further use of the machine, a guard or other part that is damaged should be checked to determine that it will operate properly and perform its intended function. Check for alignment of moving parts, breakage of parts, mounting, and other conditions that may affect its operation. A guard or other part that is damaged should be properly repaired or replaced.

**NEVER OPERATE A MACHINE WHEN TIRED, OR UNDER THE INFLUENCE OF DRUGS OR ALCOHOL.** Full mental alertness is required at all times when running a machine.

**IF AT ANY TIME YOU ARE EXPERIENCING DIFFICULTIES** performing the intended operation, stop using the machine! Then contact our service department or ask a qualified expert how the operation should be performed.

**DO NOT MODIFY OR ALTER THIS EQUIPMENT** in any way. If modifications are deemed necessary, all such requests must be approved and/or handled by Rottler Manufacturing. Unauthorized modifications could cause injury and/or damage to machine and will void the warranty.

**SAFETY DECALS SHOULD NEVER BE REMOVED.** They are there to convey important safety information and warn of potential hazards.

**ALL LOCAL SAFETY CODES AND REGULATIONS** should be followed when installing this machine.

**ONLY QUALIFIED PERSONAL** should perform service on the electrical and control systems.

When boring the machine is capable of throwing metal chips over 10- feet from the cutting area. Always use the guards. Eye protection must be worn at all times by the operator and all other personnel in the area of the machine.



**CAUTION** No list of safety guidelines can be complete. Every piece of shop environment is different. Always consider safety first, as it applies to your individual working conditions. Use this and other machinery with caution and respect. Failure to follow guidelines could result in serious personal injury, damage to equipment or poor work results.

### Electrical Power

**THIS MACHINE IS AUTOMATICALLY CONTROLLED AND MAY START AT ANYTIME**

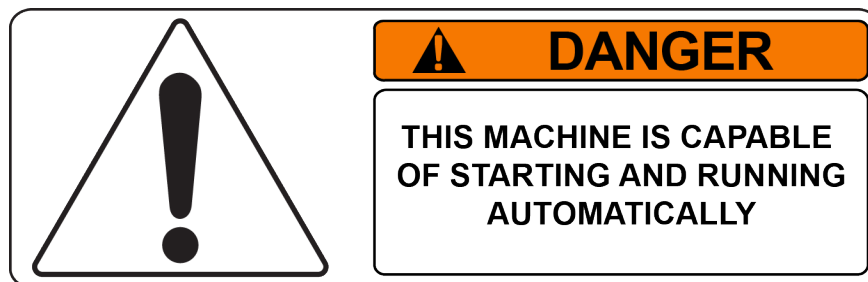

All electrical power should be removed from the machine before opening the rear electrical enclosure. It is recommended that the machine have a electrical LOCK-OUT device installed.

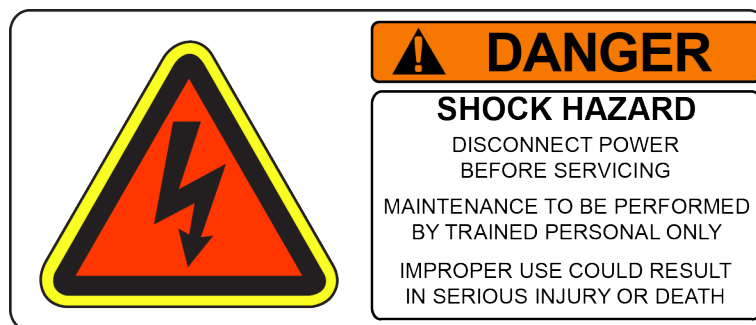

Make sure all electrical equipment has the proper electrical overload protection.

In the event of an electrical short, grounding reduces the risk of electric shock by providing a path of least resistance to disperse electric current.

Electrocution or a fire can result if the machine is not grounded correctly. Make sure the ground is connected in accordance with this manual. **DO NOT** operate the machine if it is not grounded.

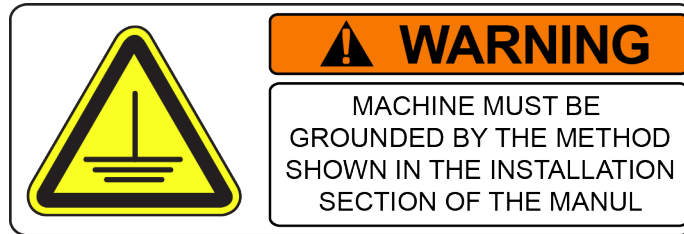

**CAUTION** No single list of electrical guidelines can be comprehensive for all shop environments. Operating this machinery may require additional electrical upgrades specific to your shop environment. It is your responsibility to make sure your electrical system comply with all local codes and ordinances.

**WARNING** This machine operates under computerized control and, as is all computerized equipment, and is susceptible to extraneous electrical impulses internally for externally produced. The machine may make moves out of the operator control at any time. The operator should work in and around the machine with caution at all times.

The operator and nearby personnel should be familiar with the location and operation of the Emergency Stop Button.

Make sure all electrical equipment has the proper overload protection. ***This machine should have a fully isolated power supply*** to prevent damage and uncontrolled movement of the machine. If this machine is on the same power lines that are running to other electrical equipment (grinders, welders, and other AC motors) electrical noise can be induced into this machines electrical system. Electrical noise can cause the controller to see false signals to move. Not supplying a fully isolated supply to the machine may void factory warranty. Refer to the Power supply section located in the Installation section for voltage and

## Machine Operator

The operator of this machine should be a skilled machinist craftsman who is well versed in the caution, care, and knowledge required to safely operate metal cutting tools.

If the operator is not a skilled machinist he/she must pay strict attention to the Operating Instructions outlined in this manual, and get instruction from a qualified machinist in both production and operation of this machine.

This machine has the following areas of exposed moving parts that you must train yourself to respect and stay away from when they are in motion:

**Cutting Tool Area** – Any operation involving hands in the cutter head area, such as inspection or alignment of the cutter head or tools, changing Centering Fingers, tool insertion, and removal, cutter head changes, and size checking etc. requires the machine to be in Neutral.

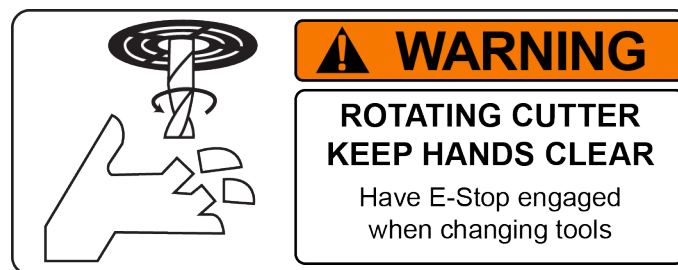

**Machining** – Eye protection must be worn during all operations of the machine. Hands must be kept completely away from the cutter head. All chip guards must be in position during machine operations.



**CAUTION** **Work Loading and Unloading** – Carefully develop handling methods of loading and unloading work pieces so that no injury can result if hoist equipment or lift connection should fail. Periodically check lift components for damage that may cause failure.

**CAUTION** **Machine Maintenance** – Any machine adjustment, maintenance or parts replacement absolutely requires a complete power disconnection from the machine, *this is an absolute rule.*

## Emergency Procedure

Assuming one of the following has occurred: tool bit set completely off size, work piece or spindle base not clamped, spindle is not properly centered, and these mistakes will become obvious the minute the cut starts

**PRESS THE EMERGENCY STOP BUTTON** (on the front control panel) **IMMEDIATELY!**

Find out what the problem is; return the spindle to its up position without causing more damage. To restart the machine, turn the Emergency Stop Button CW until the button pops out

Be alert to quickly stop the machine in the event of a serious disruption of the boring process either at the top or bottom of the bores.

**“REMEMBER”** metal cutting tools have the speed and torque to severely injure any part of the human body exposed to them.

## Computer and Controller System Safety

The computer and controller are located in the main rear electrical enclosure. This unit is a full computer, running Windows 7 64 Bit operating system. Contact the factory if more information on the computer system is required.

**IMPORTANT** The computer in this machine has the ability to connect to the World Wide Web via Ethernet or Wireless using a USB wireless (Wi-Fi) adapter. Updating the Rottler software should **ONLY** be done when directed to do so by a Rottler service technician. Updating Rottler Software when not directed by Rottler personnel will result in a non-operational machine.

The machine should be hooked up to the Internet anytime it is on. The software on the machine will automatically connect to our server to send back useful information on machine status.

The Auto Update for the Windows Firewall (Security) and Windows Defender (Anti-Virus) is turned on. The computer will automatically download the updates and then install them when the computer is shut down every Friday night.

Any “IT” personnel should **ALWAYS** get approval from Rottler before doing ANYTHING on the computer.

**⚠ DANGER** This machine is capable of causing severe injury or death. Doing any of the following without Rottler’s direct consent may cause severe injury or death.

**IMPORTANT** Downloading ANY program from the Internet or by other means when not directed by Rottler is prohibited and will result in the machine warranty being NULL and VOID.

**IMPORTANT** Downloading any program or changing any Rottler or Computer settings may cause the machine and/or software to become unstable. **DO NOT** install ANY screen saver, Anti-Virus, Spyware or any type of Security software on the computer. This could create a hazardous environment for the operator and personnel around the machine. Performing any of the above will also result in the machine warranty being NULL and VOID.

**IMPORTANT** **DO NOT** connect any type of external hardware to the computer via USB or any other means. Do not install any type of Device Driver. This could create a hazardous environment for the operator and personnel around the machine. Performing any of the above will also result in the machine warranty being NULL and VOID.

This page intentionally left blank

# CONTROL DEFINITIONS

## Contents

<b>Control Definitions .....</b>	<b>4-1</b>
<b>Computer and Controller System Safety for DM Controlled Machines.....</b>	<b>4-1</b>
Master Power On/Off Switch .....	4-2
<b>Initialization Screen.....</b>	<b>4-3</b>
<b>General Information .....</b>	<b>4-3</b>
<b>Home.....</b>	<b>4-3</b>
<b>Program Select .....</b>	<b>4-3</b>
New.....	4-4
Options .....	4-4
Delete .....	4-4
<b>Mode Select.....</b>	<b>4-5</b>
New.....	4-5
Std (Standard) Setup .....	4-6
Options .....	4-6
Delete .....	4-7
<b>Manual Cylinder Bore.....</b>	<b>4-7</b>
Set Zero Tab.....	4-7
Actual Position .....	4-7
Velocity Override.....	4-7
Zero Buttons.....	4-7
Handwheel Buttons .....	4-8
Spindle Start.....	4-8
CW and CCW Creep.....	4-8
Jog Buttons .....	4-8
Move to .....	4-8
Move To Zeros .....	4-8
CW and CCW Index.....	4-8
Setting Spindle Index .....	4-8
<b>Operation.....</b>	<b>4-9</b>
Bottom of Bore .....	4-9

## Control Definitions

The purpose of this chapter is to define the function of the buttons throughout the various screens. Certain button functions may not make sense right away in this chapter. As the operator reads through the Operating Instructions chapter of this manual, the function of these buttons will become clear.

### Computer and Controller System Safety for DM Controlled Machines

The computer and controller are located in the main rear electrical enclosure. This unit is a full computer, running Windows 7 64 Bit operating system. Contact the factory if more information on the computer system is required.

**IMPORTANT:** The computer in this machine has the ability to connect to the World Wide Web via Ethernet or Wireless using a USB wireless (Wi-Fi) adapter. Updating the Rottler software should ONLY be done when directed to do so by a Rottler service technician. Updating Rottler Software when not directed by Rottler personnel could result in a non-operational machine.

It is recommended that the machine be hooked up to the Internet anytime it is on. The software on the machine will automatically connect to our server to send back useful information on machine status. It will also record performance parameters that will be used to evaluate any occurrence of a malfunction.

The Auto Update for the Windows Firewall (Security) and Windows Defender (Anti-Virus) is turned on. The computer will automatically download the updates and then install them when the computer is shut down every Friday night.

Any "IT" personnel should ALWAYS get approval from Rottler before doing ANYTHING on the computer.



Downloading ANY program from the Internet or by other means when not directed by Rottler is prohibited and will result in the machine warranty being NULL and VOID.



Downloading any program or changing any Rottler or Computer settings may cause the machine and/or software to become unstable. DO NOT install ANY screen saver, Anti-Virus, Spyware or any type of Security software on the computer. This could create a hazardous environment for the operator and personnel around the machine. Performing any of the above will also result in the machine warranty being NULL and VOID.



**Master Power On/Off Switch**

This switch is located on the main electrical control enclosure on the right hand side of the machine. The switch must be in the off position before opening the rear enclosure door.

When first applying power to the machine the computer will need to boot up. Be patient, it will take several minutes to complete booting. The Rottler program will not automatically start. Double tap the Rottler\_WPF icon on the screen to start Rottler.

When turning the main power to the machine off there is a specific procedure to follow so as not to damage the computer. The computer must shut down its internal systems before main power is removed from it.

Press the “Start” button in the left-hand side of the Start Bar. This will bring up the “Start Menu”. Press the “Shutdown” line at the bottom of the Start Menu. This will bring up a Pop Up menu, make sure that “shut down computer” is selected and press “OK”.

This will shut down the computer. It is now OK to turn Main Power off to the machine.

## Initialization Screen

When the F103/4/5M is powered up the Rottler program will not automatically start. It may take several minutes for the computer to power. Start the Rottler program by double tapping the Rottler\_WPF icon on the desktop. Once the program is started, the Rottler Program Select will appear.

NOTE: Do not push any buttons or icons on the screen before the Rottler program starts or an error may be caused on the computer.

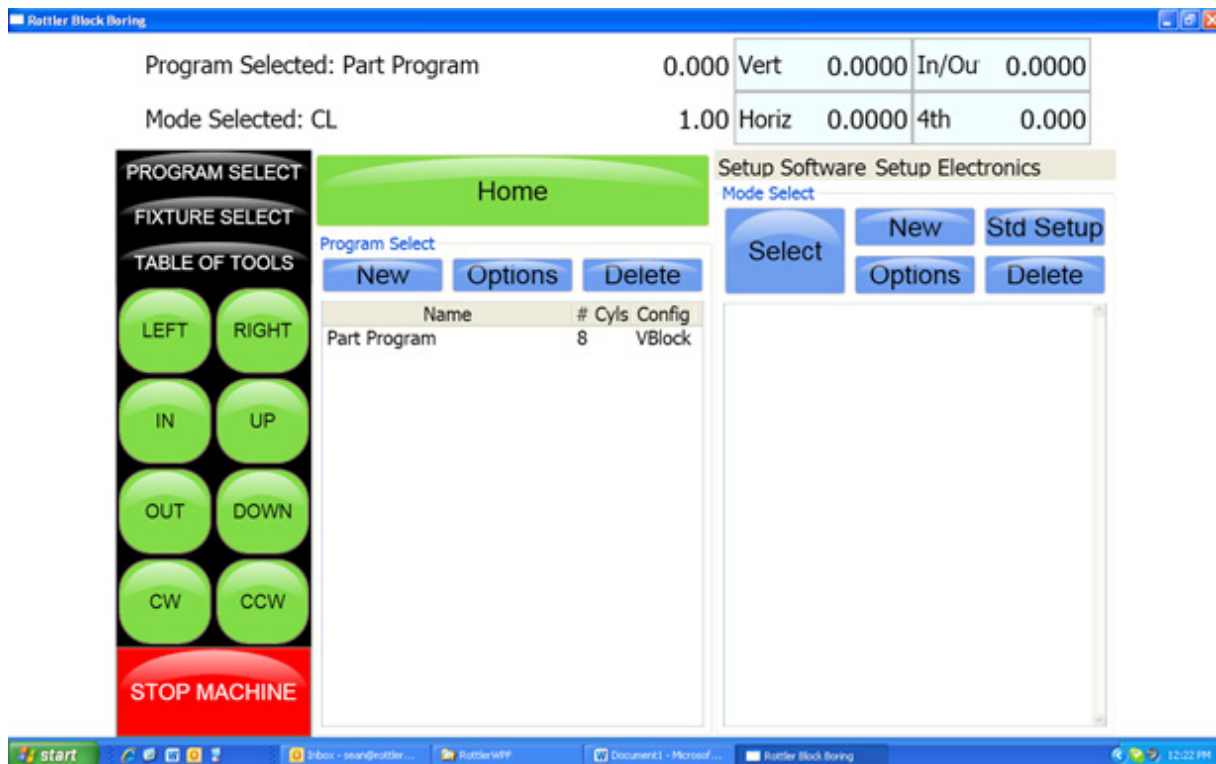

## General Information

The Rottler software operates on a Block Model format. You select or create the block you are working with. Then select or create an operation to be performed on that block.

### Home

Pressing this button will cause the machine to move all axis to their home (Machine Origin) position. The vertical will home first to be sure it is clear to move the other axis. The machine MUST be homed after it is turned on. This is how the machine gets its reference points to operate.

### Program Select

This is the left section of the screen. This is where you create and select blocks you will be working with.

## New

Pressing this in the Upper level will cause a dialog box to appear. Here is where you name and configure the block, the number of cylinders and Inline or V Block.

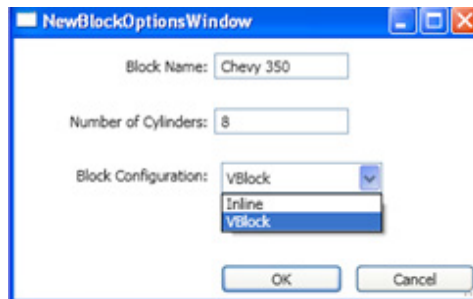

Pressing OK will result in the Block Model being inserted into the left hand side of the screen.



## Options

This will bring up the same dialog box as described above if any of the information needs to be changed.

## Delete

This will delete whatever block program is selected. A dialog box will appear to ask you if you want that program deleted.

## Mode Select

This is the right section of the screen. This is where you create or select operations to be performed on the selected Block. This area will be blank when you first create a block.

You can create only certain modes you will use on a block or use a standard set up that inserts all modes available. You can also create a new mode and rename it for a specific use.

### New

Pressing this button will bring up a dialog box with Rottler standard operations.

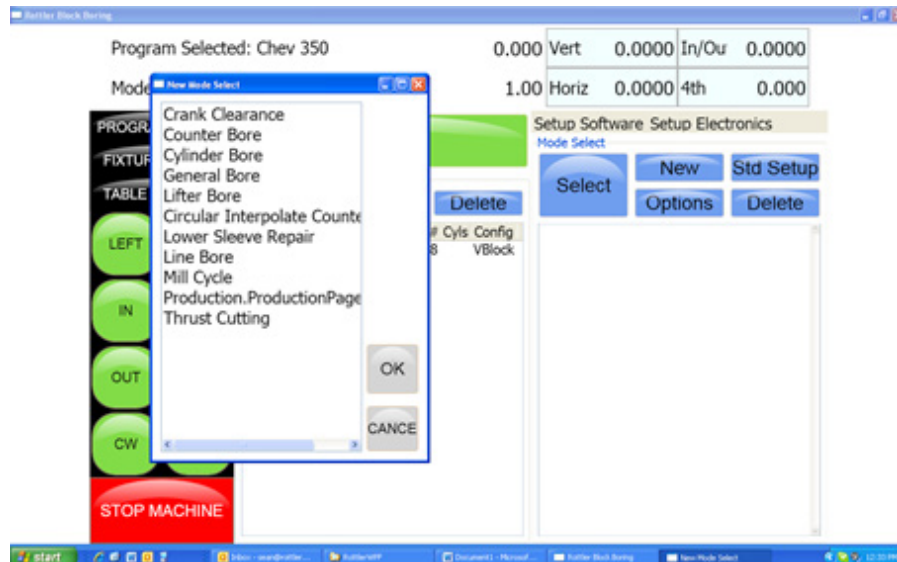

Select the operation you want to create and then press OK. This will place a general Bore operation under the Cylinder bore mode in the right hand section.



To enter General Bore mode highlight it and then press Select. This will take you to the operation screens that will be described later.

## Std (Standard) Setup

Pressing this button will insert all the Rottler operations into the right hand section automatically.



Use the slide bar on the right hand side to scroll through all the operations.

## Options

Press this button to bring up a dialog box to allow positive numbers to be entered in the horizontal stops. Most all programs are from left to right, the farther right you go the larger the negative number. However if a different zero point is used a positive number may be needed. For example, if you zero on the first cylinder on the left bank of a block and then "roll it over" the first cylinder is farther to the right than the zero position. Which would be a positive number.

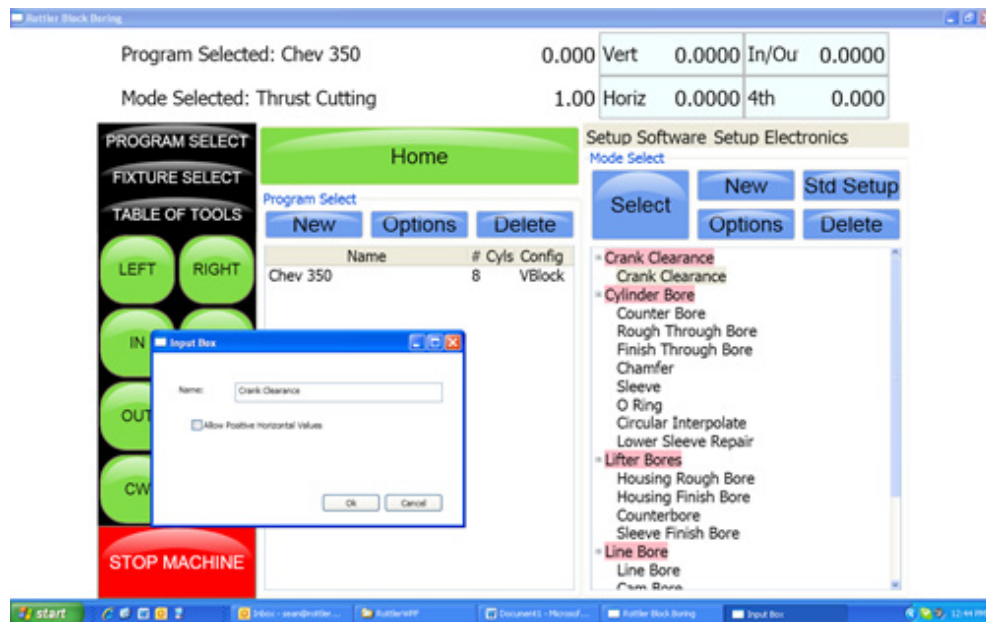

## Delete

This will delete the selected Mode. It will ask you if you want this mode deleted before deleting it.

NOTE: Once the control definition for a particular button has been discussed it will not be repeated in the different modes of operation. Only new buttons or buttons with a different function will be discussed in different modes.

## Manual Cylinder Bore

Each buttons function will be described in this section. In the different MODES, the same buttons will not be described again.

### Set Zero Tab



### Actual Position

These are a numerical display showing the actual distance the axis are away from where they have been zeroed.

### Velocity Override

The Velocity override is displayed in the upper left of the Actual Position display. The default is 100% of the programmed Feed Rate. When operating... turning the handwheel Counter Clockwise will override the axis rapid travel and feed rate 100 and 0% when in an automatic cycle.

### Zero Buttons

These buttons will erase the actual position display of their associated axis and reset the displayed value to zero.



**Handwheel Buttons**

These buttons will activate their associated axis for use with the handwheel. The left button of each axis will move the machine in .010" per detent, the middle button .010" per detent and the right .0001" per detent of the handwheel. Pressing any of the axis Jog buttons will disengage the handwheel.

**Spindle Start**

This button will start the spindle at the RPM that is specified on the Auto Bore Cycle tab. Once the button has been pressed and the spindle is running the button will turn red and read Spindle Stop. Pressing the button again will stop the spindle and cause the button to go back to green.

**CW and CCW Creep**

These buttons will cause the spindle to rotate slowly CW or CCW direction. The spindle will continue to rotate as long as the button is pressed. The speed at which the spindle will rotate is set in the Machine Parameters and should not be changed unless instructed to do so by the factory.

**Jog Buttons**

These buttons control the rapid travel of the Vertical, Horizontal and In/Out axis. Pressing these buttons will allow you to move the machine through all ranges of its travel unobstructed. If the spindle is turned on these buttons become feed buttons and the machine will feed in whatever direction you have pressed. The rate at which the machine will feed is determined by the value set in the Auto Bore Cycle tab. When in rapid travel, these buttons are momentary contact and you will have to keep them pressed to keep the machine moving. When the spindle is on, they are latching buttons and once they are pressed the travel will continue until they are pressed again.

**Move to**

Pressing these buttons will bring up a dialog box for the associated axis. Enter a value that you want the axis to move to and press ENTER. That axis will then move to that position. You can do multiple "Move To" at the same time. One after another.

**Move To Zeros**

Pressing this button will cause the vertical to move the zero position first. The in/out and horizontal will move after the vertical has moved to zeros.

**CW and CCW Index**

Pressing either of these buttons will cause the spindle to rotate to the index position. Index position is with the tool to the right as you are facing the machine.

***Important:*****Setting Spindle Index**

Any time the machine has been turned off the spindle index position must be set. Turn the spindle to the index position (tool holder facing to the right at 90 degrees from the operator). Then press the Zero button next to the spindle position read out. This will put a zero value in the display box.

This screen also shows the Spindle Load, programmed Feed Rate and Spindle RPM.

## Operation

This screen is used to set the Vertical stop and final RPM the machine will use to bore a cylinder.

Program Selected: Part Program	0.000	Vert	0.0000	In/Out	0.0000
Mode Selected: Manual Cylinder Bore	1.00	Horiz	0.0000	4th	0.000

**PROGRAM SELECT**

LEFT RIGHT

IN UP

OUT DOWN

CW CCW

**STOP MACHINE**

**Set Zeros**

**Operation**

**DEPTHS**

Bottom of Bore

Stop and Index Spindle After Cycle

**DWELL OPTIONS**

Finish RPMS

Finish Revolutions

**START AUTO CYCLE**

### Bottom of Bore

Set this stop to the length of the bore. This will be a negative number. The boring cycle will start at Vertical 00.000.



# OPERATING INSTRUCTIONS

## Contents

<b>Operating Instructions .....</b>	<b>5-1</b>
<b>  Loading Blocks.....</b>	<b>5-1</b>
<b>  Small Gas and Diesel .....</b>	<b>5-1</b>
Manual V6/V8 Combination Fixture 502-1-72H.....	5-1
Boring Application.....	5-1
<b>  Normal Operating Procedure .....</b>	<b>5-3</b>
Surfacing Application .....	5-5
<b>  Normal Operating Procedure .....</b>	<b>5-7</b>
<b>  Retrofitting 502-1-15C Parallels to V6/V8 Combination Fixture .....</b>	<b>5-8</b>
<b>  Diesel Blocks .....</b>	<b>5-10</b>
<b>  6725 Diesel Fixture .....</b>	<b>5-10</b>
Small Diesel V Blocks.....	5-10
Triangle Clamping.....	5-11
Block Clamp Arm .....	5-11
<b>  Small Diesel In Line Blocks .....</b>	<b>5-13</b>
Triangle Clamping.....	5-14
<b>  6405F Large V-Block .....</b>	<b>5-16</b>
Triangle Clamping.....	5-17
<b>  6810 Waukesha 7042, 9390 and CAT 379, 398, 399 Block Line Bore Fixture.....</b>	<b>5-21</b>
<b>  6821 Adjustable, Universal Line Bore Parallel Assembly.....</b>	<b>5-25</b>
<b>  7119V Dual Axis Table Assembly .....</b>	<b>5-30</b>
Instructions for Small In-Line Blocks .....	5-31
Mounting Block to Table.....	5-31
Blocks with Main Caps Removed or Raised Main Bearings.....	5-31
Blocks with Main Caps Installed .....	5-32
Typical Head Set Up Procedure.....	5-33
<b>  12” Multi Tooth Milling Head - 6865 .....</b>	<b>5-36</b>
<b>  18” Multi Tooth Milling Head 6864 .....</b>	<b>5-36</b>

<b>General Machine Information</b> .....	<b>5-37</b>
<b>Homing</b> .....	<b>5-37</b>
<b>Building Programs</b> .....	<b>5-38</b>
<b>Create a Block Program</b> .....	<b>5-38</b>
New.....	5-38
Options .....	5-38
<b>Creating Operating Modes for a Block Model</b> .....	<b>5-38</b>
New.....	5-38
<b>Std (Standard) Setup</b> .....	<b>5-40</b>
Select .....	5-40
Options .....	5-40
<b>Manual Cylinder Bore</b> .....	<b>5-41</b>
Setting Zeros .....	5-41
Horizontal and In/Out Zero.....	5-41
Vertical Zero .....	5-41
<b>Operation</b> .....	<b>5-42</b>
Bottom of the Bore .....	5-42
Stop and Index Spindle after Cycle.....	5-42
Finish RPMS and Revolutions .....	5-42
Start Auto Cycle .....	5-42
<b>Manual Lower Sleeve Repair</b> .....	<b>5-43</b>
Start Boring Height .....	5-43
Horz Clearance .....	5-43
Horiz Overshoot .....	5-43
Bottom of Bore .....	5-43
Start Auto Cycle .....	5-43
<b>Manual Line Bore</b> .....	<b>5-44</b>
Bore Length.....	5-44
Start Auto Cycle .....	5-44
<b>Manual Mill</b> .....	<b>5-45</b>
Horizontal End.....	5-45
Start Auto Cycle .....	5-45

## Operating Instructions

The purpose of this chapter is to explain and then guide the operator from loading a block through running an automatic cycle.

All modes of operation will be discussed in this chapter.

**Note:** *We recommend, particularly for operators unfamiliar with the boring machine, to practice on a junk block in order to become familiar with the controls and procedures of the boring machine.*

### Loading Blocks

#### Small Gas and Diesel

##### Manual V6/V8 Combination Fixture 502-1-72H

 Handle the block and fixture with EXTREME care and guidance. A block hoist is REQUIRED. Mishandling of a heavy engine block and fixture may result in the dropping of parts and personal injury.

The Model 502-1-72H manual V6/V8 combination fixture is a fast, simple and universal system to properly and accurately hold most 60 degree V-type engine blocks for either cylinder boring or deck surfacing.

See illustration on the following page.

#### Boring Application

**NOTE:** *The block must have the main bearing caps in place and torqued.*

Care must be taken to assure the contact edges of the locator bar are near the cap split line. A pair of 3/8" and 1/2" spacers are provided for blocks with large main bearing bores, to enable the bar to locate near the main bearing split line. (See figure 2)

**V-blocks:** (blocks with main bearing center lines no more than 1/2" higher than the pan rail plane) are mounted with the 502-3-8B V-block frame in place. Select the 90-degree option placement of the frame to suit block length, or main bearing caps will interfere with frame. Rotate frame 90 degrees by moving its shoulder screws to alternate set of holes.

**Y-Blocks:** (blocks with main bearing center lines 2-3/8" to 3-1/2" higher than the pan rail plane) are mounted directly on the fixture. Some Y-blocks (GM 60 degree) have too narrow pan rails and some have too low main bearing location which will require the use of the 502-1-15C precision 1-1/4" x 3" parallel set to raise and or support the block. Use the shoulder screw from the V-block frame and hook the parallels over the back of the V-fixture.

This fixture may be easily repositioned on the support parallels (without a block in place) to shift from the 60 degree support surface to the 90 degree support surface or vice versa.

**⚠ WARNING**

Extreme care must be taken by operator whenever handling large blocks. Large blocks may cause fixture to tip when floated too far outward. We recommend leaving hoist attached when moving these blocks. Large blocks should be lifted from the block bank surface.

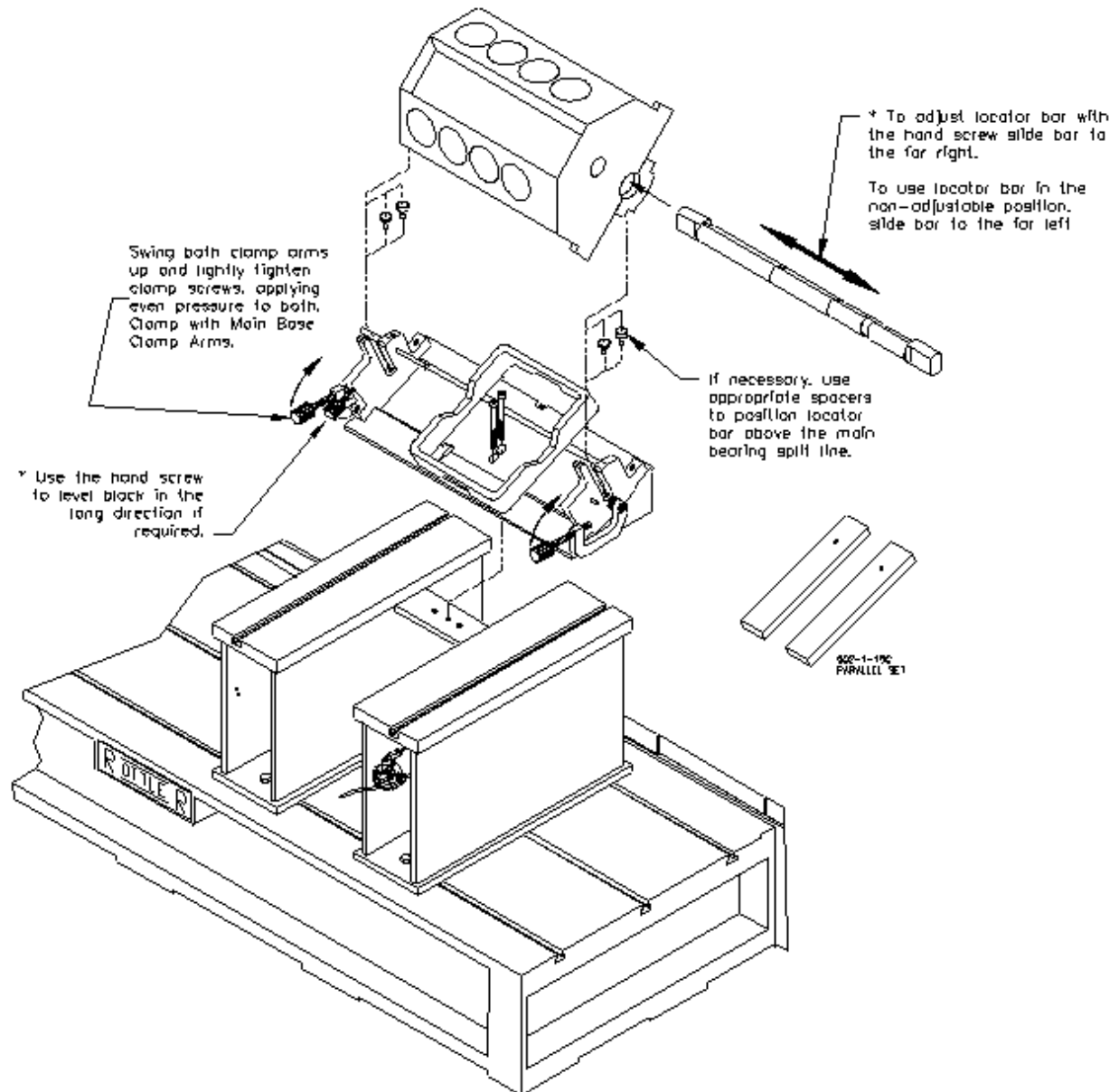

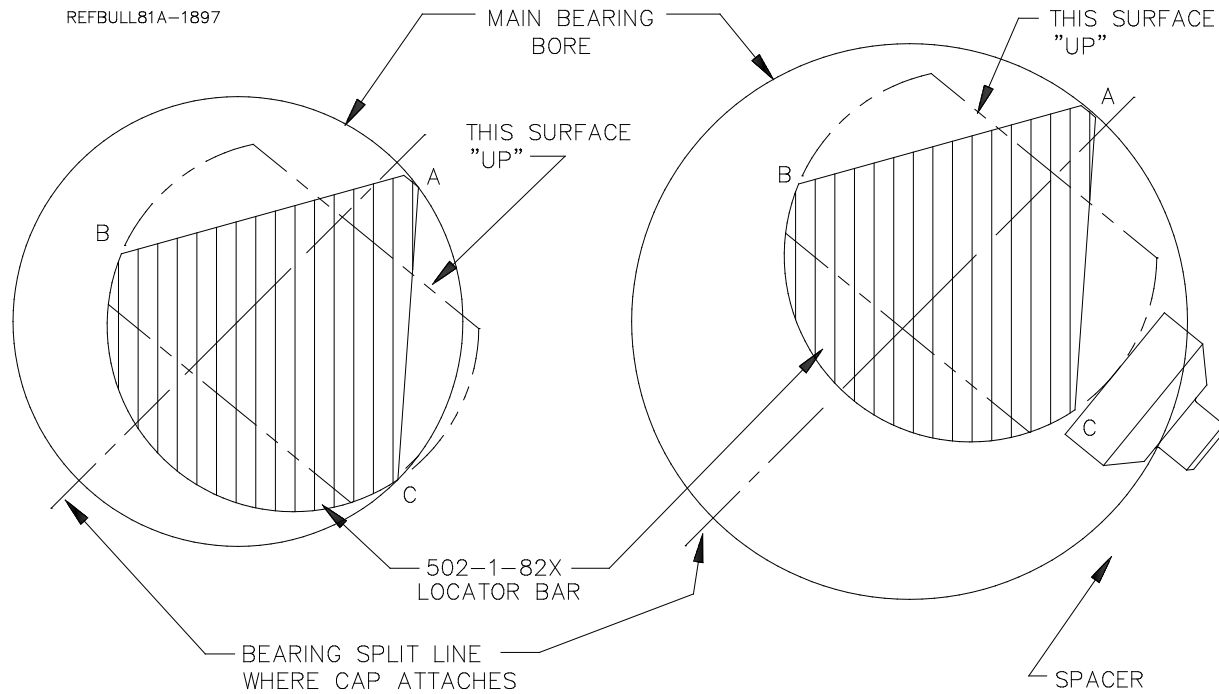

FIGURE 1

FIGURE 2

### Normal Operating Procedure

The normal operation procedure on smaller V-blocks is to first pick up the block. Place the 502-1-82X locator bar through the main bearings and hoist the block into the fixture. Pulling the block towards you, with the locator against the positioners, will prevent jamming in the slot of the guides during the loading and unloading operations. The locator bar is positioned with the word 'UP' that is on the end of the bar facing up and away from the operator. (see figure 1) After the locator bar is engaged in the positioners, pivot block outwards as you lower it. Slide block to the far left (this is the non adjustable position).

Make sure the block is firmly seated in place and not resting on pan-rail burrs or other interference points. Accurate seating can also be a problem with extremely warped, distorted blocks. Another cause of problems is failure to remove main bearing inserts. The locator bar has a relief for blocks with a small main bearing or seal. Rotate locator bar clamps into position & lightly tighten the hand screws, applying even pressure to both. Clamp the block securely with the main base clamp arms.

Warped or distorted blocks may require leveling of the deck surface in the long direction. This is possible with the hand-screw assembly in the left-hand bar positioner. Loosen both clamp hand-screws and slide the locator bar to the far right position. Retighten both clamp hand-screws. Raise or lower the adjusting hand-screw as required. For the non-adjustable position slide locator bar to the far left.

Push fixture back into bore position. There is a guide block (502-1-105) attached to the bottom of the fixture to aid in guiding the fixture along the support ways.

Operate the block clamp arms, bore, and pull fixture back to the load position.

Loosen locator bar hand screws and rotate clamps out of the way. Lift the block, either from the deck surface or with the optional 502-1-95 block handler. Turn the block 180 degrees & reload to duplicate the operation on the other bank.

After turning the engine block 180 degrees the locator bar must be twisted 180 degrees also. Again the word 'UP' must enter into the positioners facing up and away from the operator. (See figure 1).

### **Figure 1**

502-1-82X main bearing locator bar indexes at point A. When bank is reversed and the bar is twisted 180 degrees, point A still indexes the main bearing.

Point C holds the block down. When bank is reversed and the bar is twisted 180 degrees, point B holds the block down.

### **Figure 2**

502-1-82X main bearing locator bar indexes near bearing split line. Point C does not contact the bearing cap but rests on matched spacers that are provided to fit in the bar positioners slot. If there is a means of holding the block down such as block clamp towers, this method may be used in large bores in order to properly index near the bearing split line. If extreme care is used this method may be used to index blocks without bearing caps attached. (Optional clamp down must be provided).

## Surfacing Application

NOTE: The block must have the main bearing caps in place and torqued.

Care must be taken to assure the contact edges of the locator bar are near the cap split line. A pair of 3/8" and 1/2" spacers are provided for blocks with large main bearing bores, to enable the bar to locate near the main bearing split line. (See figure 2)

### V-blocks:

(blocks with main bearing center lines no more than 1/2" higher than the pan rail plane) are mounted with the 502-3-8B V-block frame in place. Select the 90-degree option placement of the frame to suit block length, or main bearing caps will interfere with frame. Rotate frame 90 degrees by moving its shoulder screws to alternate set of holes.

### Y-Blocks:

(blocks with main bearing center lines 2-3/8" to 3-1/2" higher than the pan rail plane) are mounted directly on the fixture. Some Y-blocks (GM 60 degree) have too narrow pan rails and some have too low main bearing location which will require the use of the 502-1-15C precision 1-1/4" x 3" parallel set to raise and or support the block. Use the shoulder screw from the V-block frame and hook the parallels over the back of the V-fixture.

This fixture may be easily repositioned on the support parallels (without a block in place) to shift from the 60 degree support surface to the 90 degree support surface or vice versa.

**⚠ WARNING** Extreme care must be taken by operator whenever handling large blocks. Large blocks may cause fixture to tip when floated too far outward. We recommend leaving hoist attached when moving these blocks. Large blocks should be lifted from the block bank surface.

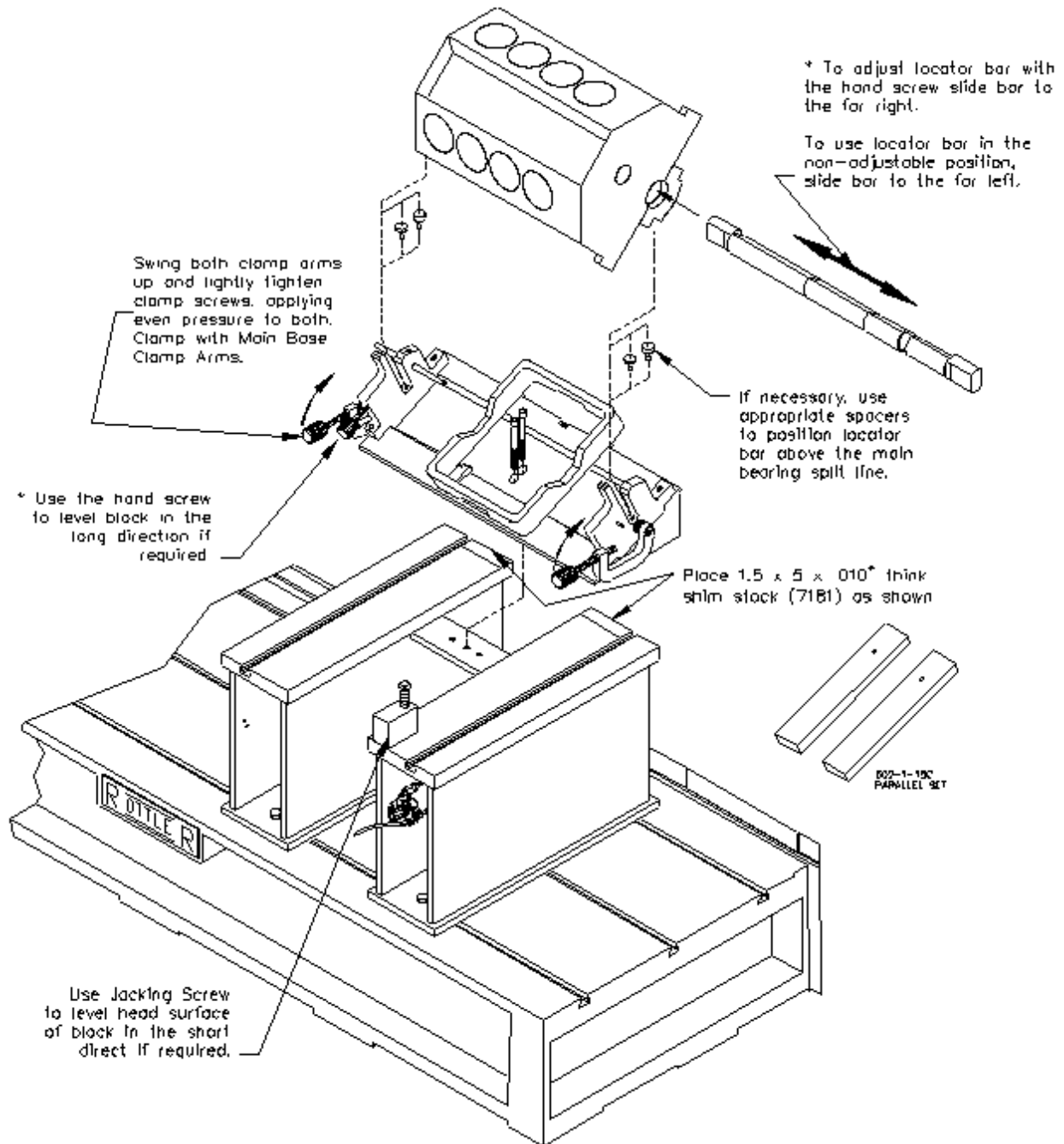



## Normal Operating Procedure

The normal operation procedure on smaller V-blocks is to first pick up the block. Place the 502-1-82X locator bar through the main bearings and hoist the block into the fixture. Pulling the block towards you, with the locator against the positioners, will prevent jamming in the slot of the guides during the loading and unloading operations. The locator bar is positioned with the word 'UP' that is on the end of the bar facing up and away from the operator. (see figure 1) After the locator bar is engaged in the positioners, pivot block outwards as you lower it. Slide block to the far left (this is the non adjustable position).

Make sure the block is firmly seated in place and not resting on pan-rail burrs or other interference points. Accurate seating can also be a problem with extremely warped, distorted blocks. Another cause of problems is failure to remove main bearing inserts. The locator bar has a relief for blocks with a small main bearing or seal. Rotate locator bar clamps into position & lightly tighten the hand screws, applying even pressure to both. Clamp the block securely with the main base clamp arms.

Warped or distorted blocks may require leveling of the deck surface in the long direction. This is possible with the hand-screw assembly in the left-hand bar positioner. Loosen both clamp hand-screws and slide the locator bar to the far right position. Retighten both clamp hand-screws. Raise or lower the adjusting hand-screw as required. For the non-adjustable position slide locator bar to the far left.

Push fixture back into surfacing position with the back of the fixture on the Shim Stock. The shim stock is put in place to raise the back side of the block, you can then use the Jacking Screw to raise and lower the front of the block. There is a guide block (502-1-105) attached to the bottom of the fixture to aid in guiding the fixture along the support ways.

Operate the block clamp arms, surface, and pull fixture back to the load position.

Loosen locator bar hand screws and rotate clamps out of the way. Lift the block, either from the deck surface. Turn the block 180 degrees & reload to duplicate the operation on the other bank.

After turning the engine block 180 degrees the locator bar must be twisted 180 degrees also. Again the word 'UP' must enter into the positioners facing up and away from the operator. (See figure 1).

### Figure 1

502-1-82X main bearing locator bar indexes at point A. When bank is reversed and the bar is twisted 180 degrees, point A still indexes the main bearing.

Point C holds the block down. When bank is reversed and the bar is twisted 180 degrees, point B holds the block down.

### Figure 2

502-1-82X main bearing locator bar indexes near bearing split line. Point C does not contact the bearing cap but rests on matched spacers that are provided to fit in the bar positioners slot. If there is a means of holding the block down such as block clamp towers, this method may be used in large bores in order to properly index near the bearing split line. If extreme care is used this method may be used to index blocks without bearing caps attached. (Optional clamp down must be provided).

### Retrofitting 502-1-15C Parallels to V6/V8 Combination Fixture

(Special Applications)

Some engine blocks with large main bores (3-1/8" and larger) cause a problem of the locator bar bottoming out in the bar positioners and/or the V-shaped relief's of the 502-3-8B V-block frame before clamping the block properly. Mounting the 502-1-15C parallel set as shown below in place of the V-block frame will provide proper clearance for clamping. Older style fixtures and parallels can be modified to this configuration using illustrations below.

V-6 blocks with one-piece 'caged' main bearing caps (all caps are connected) can interfere with 502-3-8B V-block frame. The parallel arrangement shown below will allow proper support and clamping of these blocks.

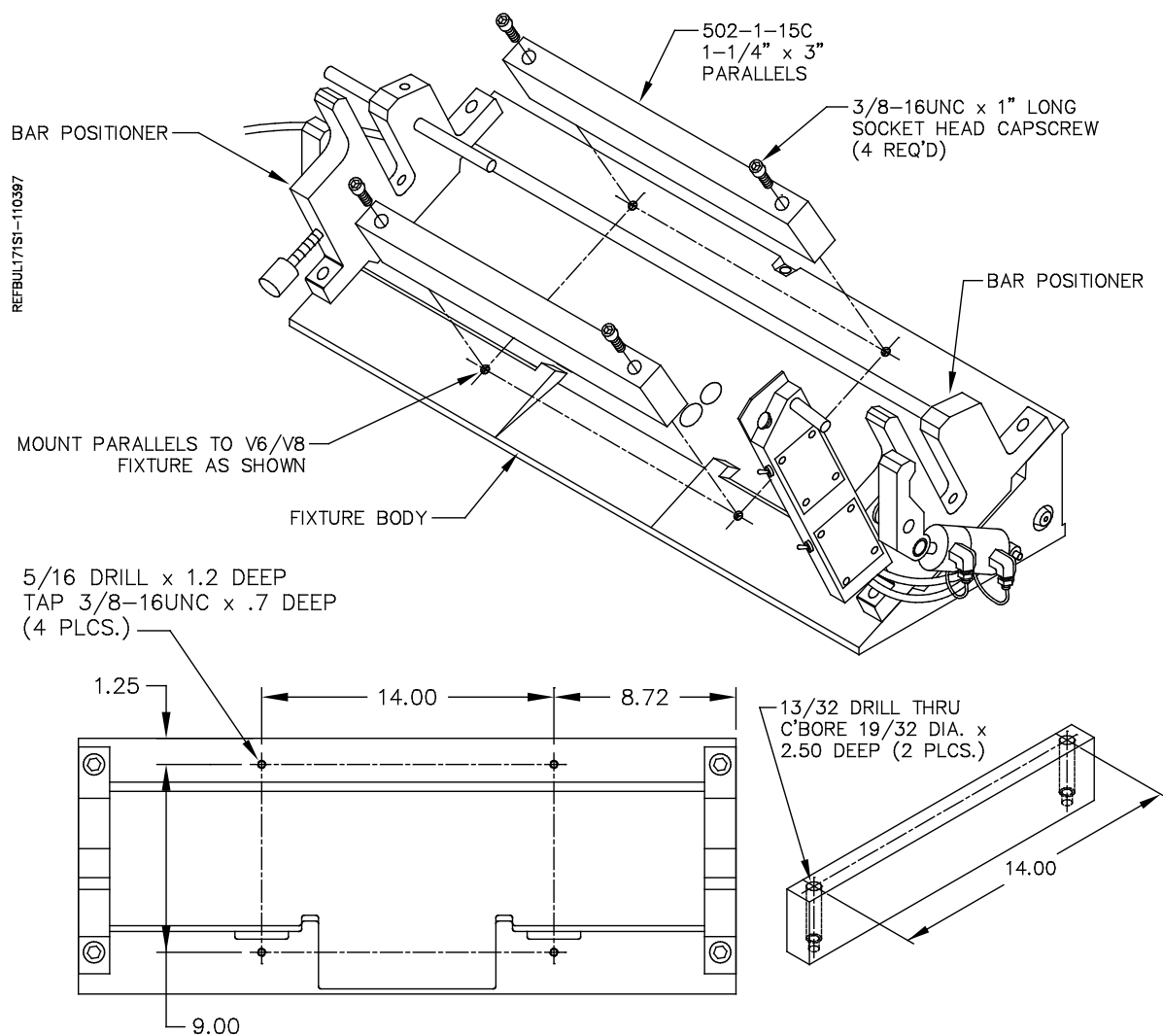

Some V-6 engine blocks (for example Buick V-6) have main bearing bores that are too low in respect to the pan rails. This presents a problem of the locator bar bottoming out in the bar positioners before the block is properly clamped. Positioning the 502-1-15C parallel set as shown below will raise the block enough to provide proper clamping.

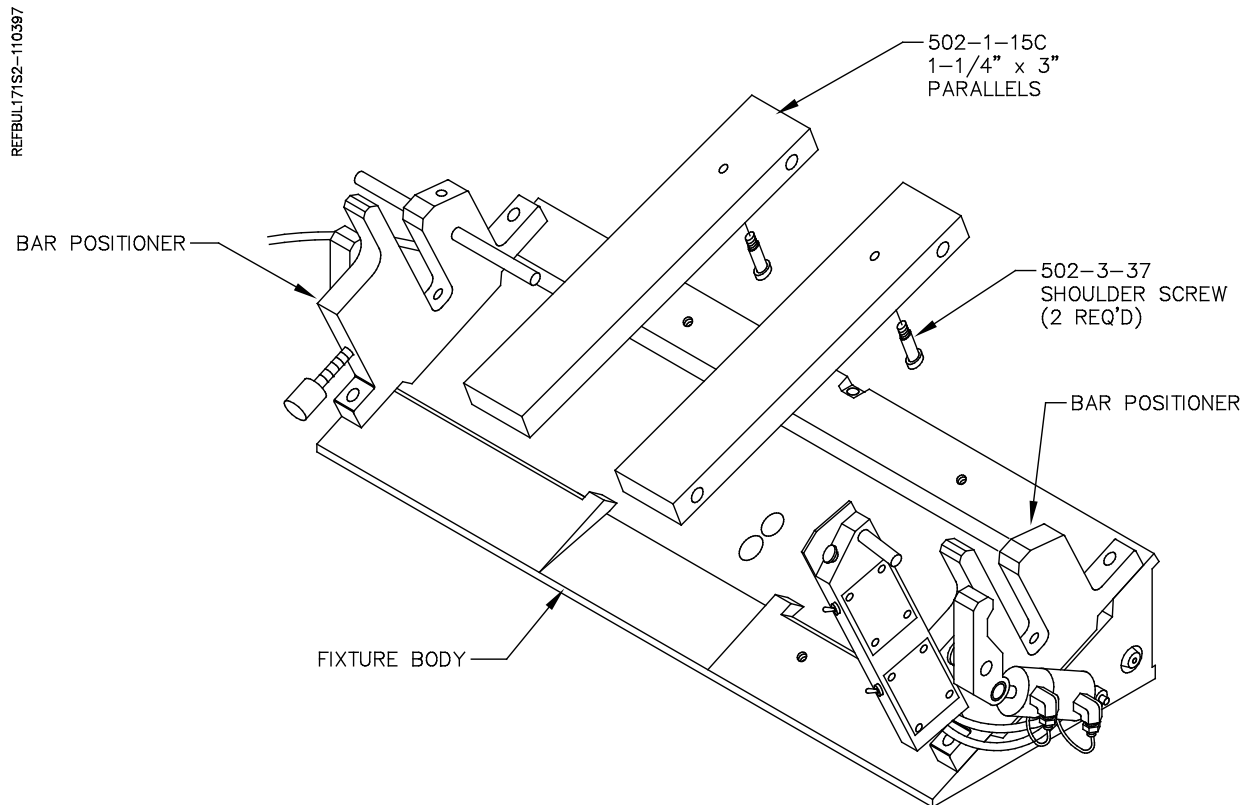

## Diesel Blocks

### 6725 Diesel Fixture

#### Small Diesel V Blocks

On these blocks it will be necessary to install the 6370Z, 10" parallels or 6794E, 8" parallels onto the bed of the machine. These parallels are keyed, place them onto the deck surface and then push them toward the rear of the machine. This will locate them evenly on the middle keyway of the machine bed. Place the two 6553F main bearing supports onto the parallels, these are also keyed and fit into the machined slots on the parallels. This will put the two main bearing supports in line with each other. Tighten all bolts to lock the parallels and main bearing support into place. Select the correct size main bearing locators and install them into the mains of the block..

**Note: Make sure there are no burrs or debris in the main bearing bores where they will contact the main bearing locators. This can cause the block not to clamp properly and may cause tipping or rocking of the block.**

#### **WARNING**

Handle these large blocks with Extreme care and guidance. A block hoist is required when handling these blocks. These blocks should be lifted from the block bank surface.

Install the main bearing locators into the mains of the engine block. Lower the block so that the locators go into the main bearing support.

#### **DANGER**

The hoist must remain attached to the block until it is firmly clamped into position. The blocks will have a tendency to tip forward until they are properly supported and clamp. When not properly supported and attached to a hoist these blocks will roll forward and out of the fixture. This will cause severe injury or death to operator.

Select the correct jacking screw to reach the block. Place the jacking screws into the jack bodies and place on the parallels in a location they will support the block from rolling forward.

Position the block clamps so the front of the shoe will clamp the block in the middle on both ends. The following illustration shows the correct triangle clamping system that should be used.

You can raise and lower the ends of the block by rotating the Hex nut located on the ends of the main bearing locators.

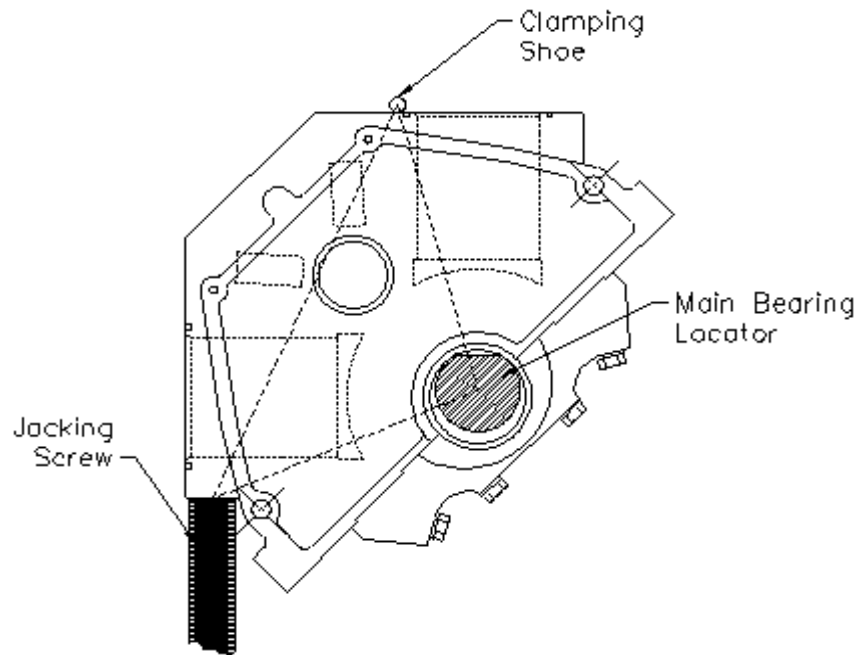
**Triangle Clamping**

Adjust the height so the shoes rest on the clamp points. Tighten the clamp leg handles. Actuate the clamp shoes by turning their knobs. Apply pressure to the two clamps as evenly as possible to avoid tipping the block up on one side.

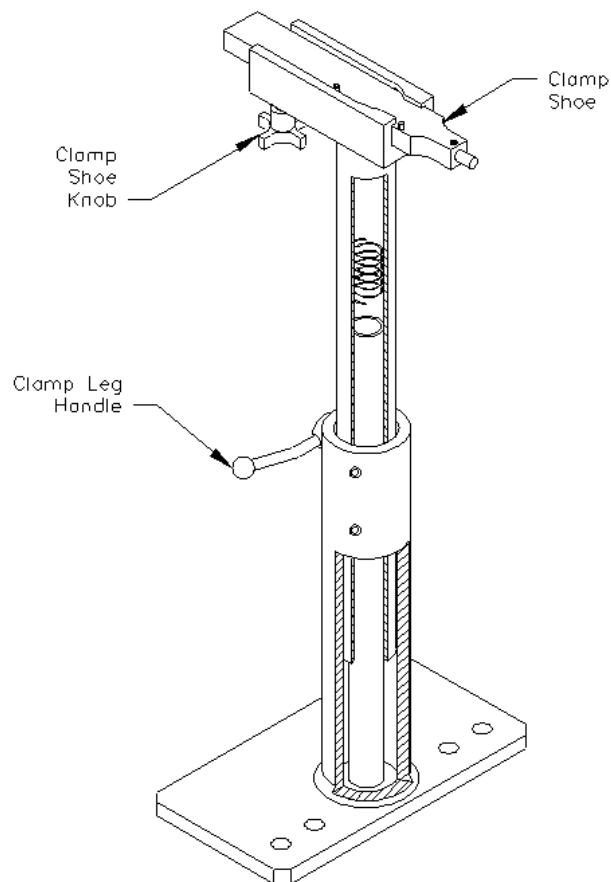
**Block Clamp Arm**

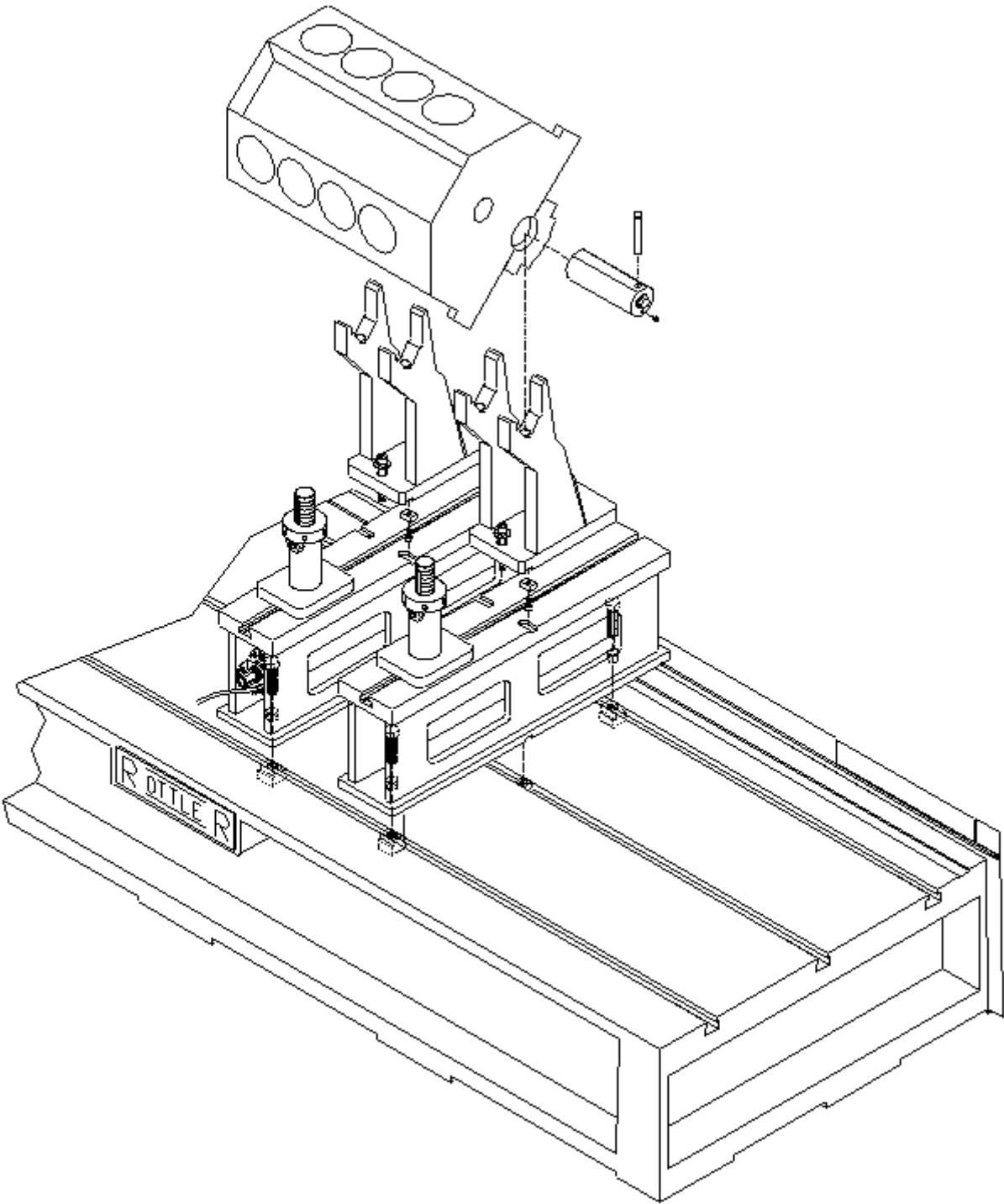

### Small Diesel In Line Blocks

On these blocks it will be necessary to install the 6370Z, 10" parallels onto the bed of the machine. These parallels are keyed, place them onto the deck surface and then push them toward the rear of the machine. This will locate them evenly on the middle keyway of the machine bed. Place the two 6553F main bearing supports onto the parallels, these are also keyed and fit into the machined slots on the parallels. Use the forward machined slots. This will put the two main bearing supports in line with each other, and on centerline of the machine bed.

Position the fixtures at a distance apart equal to the outboard main journals. Tighten all bolts to lock the parallels and main bearing support into place. Select the correct size main bearing locators, and install them into the mains of the block. Notice the locators have a flat area. Installing with the flat side up will allow end to end height adjustment of the block by rotating the locator. Installing with the round side up will position the block so all machining operations are parallel and perpendicular to the main bore centerline. This simply requires leveling the block in the front to rear direction.

**Note: Make sure there are no burrs or debris in the main bearing bores where they will contact the main bearing locators. This can cause the block not to clamp properly and may cause tipping or rocking of the block.**

 **WARNING** Handle these large blocks with Extreme care and guidance. A block hoist is required when handling these blocks. These blocks should be lifted from the block bank surface.

Lower the block so that the locators go into the main bearing support. A clevis pin is provided to keep the locator in position on the main bearing support.

For in-line blocks, load the block with the heavier side towards the front.

 **DANGER** The hoist must remain attached to the block until it is firmly clamped into position. The blocks will have a tendency to tip until they are properly supported and clamp. When not properly supported and attached to a hoist these blocks will roll forward or backwards and out of the fixture. This will cause severe injury or death to operator.

Select the correct jacking screws to reach the block. Place the jacking screws into the jack bodies and place on the machine bed in a location they will support the block from rolling forwards. Rough level the block using a spirit level.

The following illustration shows the correct triangle clamping system that should be used.

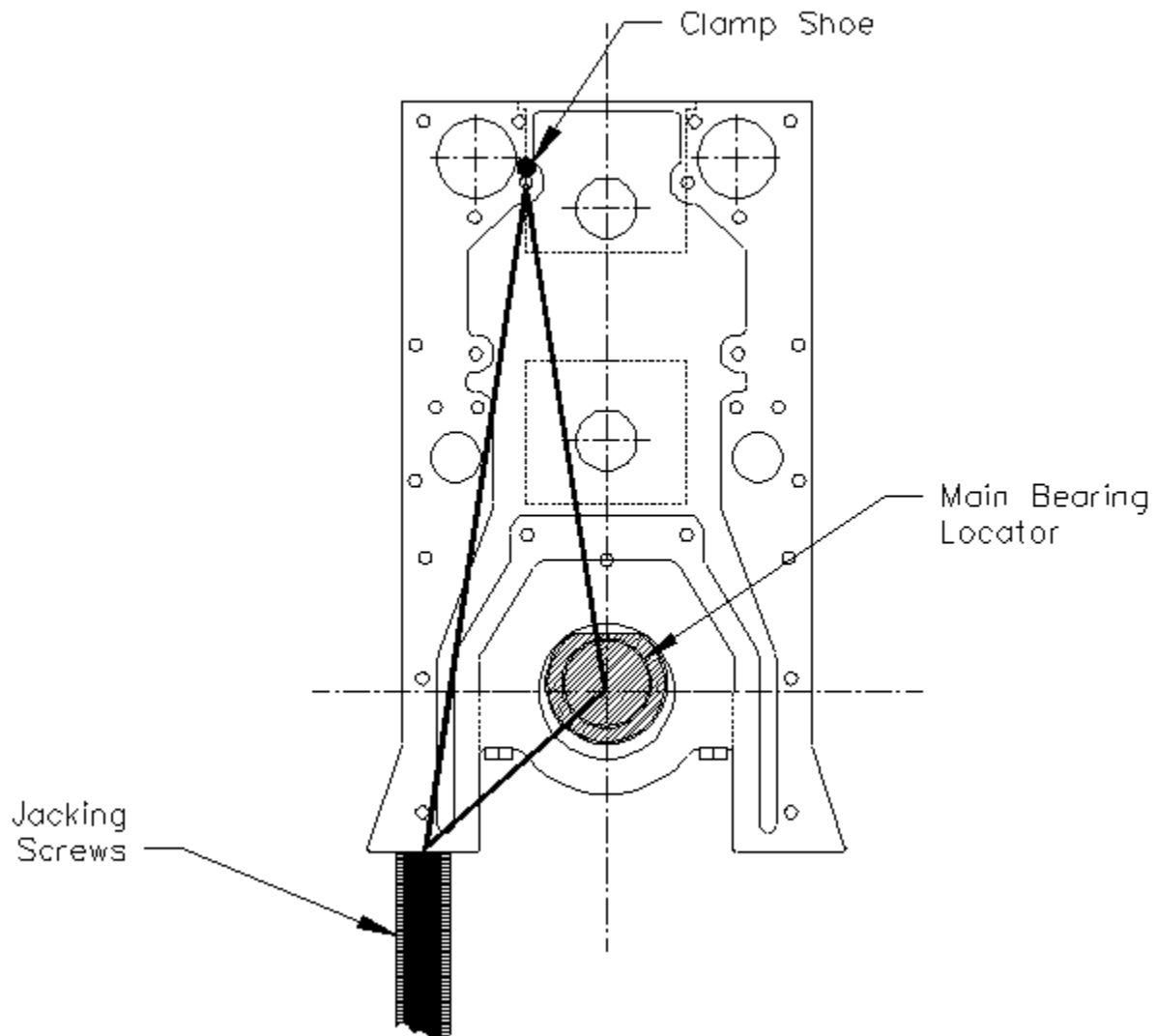
**Triangle Clamping**

Adjust the height so the shoes rest on the clamp points. Tighten the clamp leg handles. Actuate the clamp shoes by turning their knobs. Apply pressure to the two clamps as evenly as possible to avoid tipping the block up on one side.

Be sure the clamp is below the deck surface if you to resurface the block.

**⚠ WARNING**

Do not release the hoist or lifting device from the block until the clamping is secure.



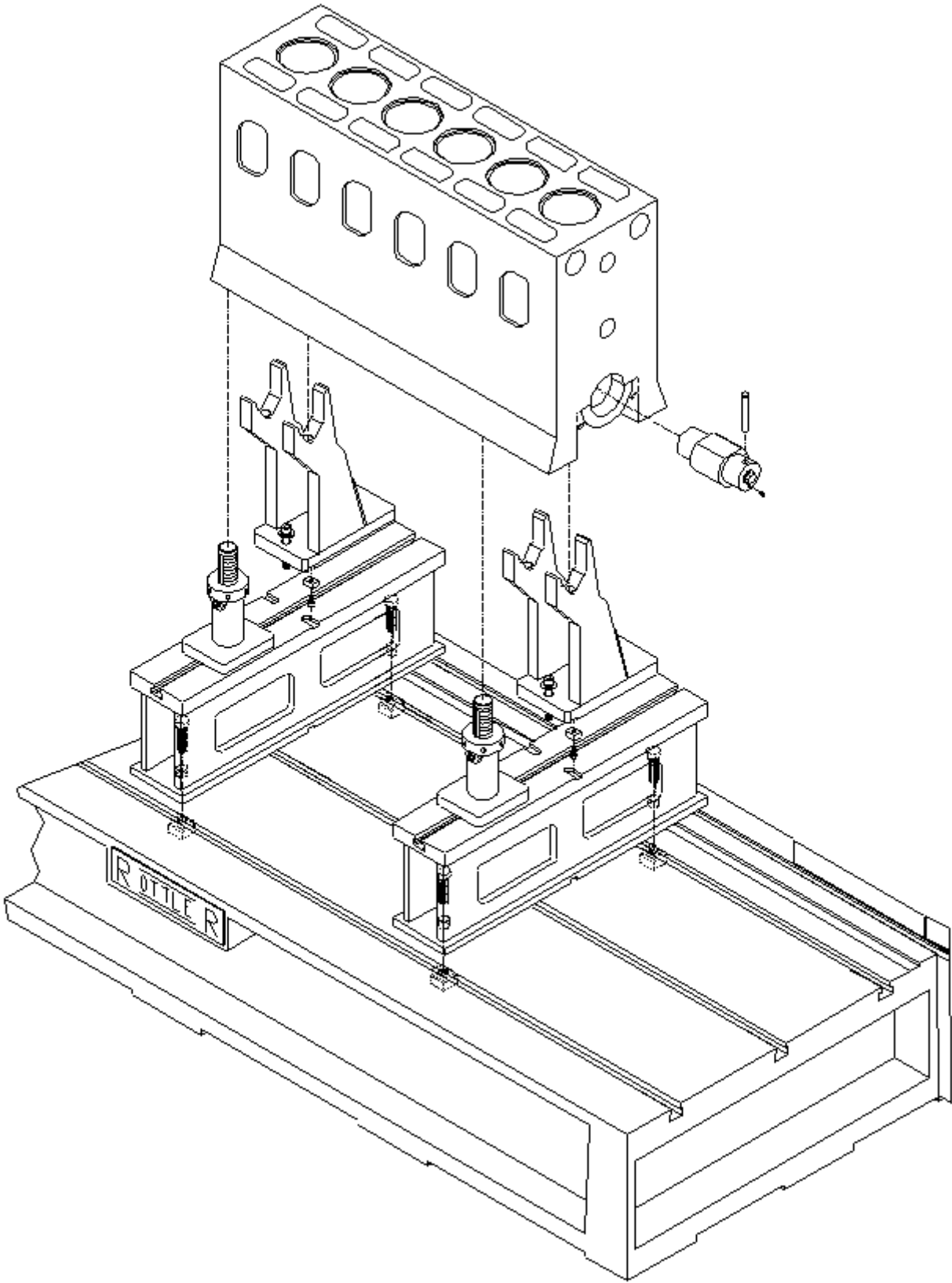



## 6405F Large V-Block

Place the 6405 supports on the machine bed. Make sure there is no debris or burrs on the mating surfaced. The supports should be placed on the machine bed with the two dowels on the bottom of the supports into the middle keyway. Place the supports the same distance apart as the mains you will be using. On long blocks, it is recommended to use main bearing locations inward from the ends, to more equally balance the block and avoid sag. Push the supports back toward the rear of the machine against the dowel pins. This will line the supports up with each other. Tighten the four (4) mounting bolts on each support.

Install the correct size locators into the main bores that will be used.

 **WARNING** Handle these large blocks with Extreme care and guidance. A block hoist is required when handling these blocks. These blocks should be lifted from the block bank surface.

 **DANGER** The hoist must remain attached to the block until it is firmly clamped into position. The blocks will have a tendency to tip until they are properly supported and clamp. When not properly supported and attached to a hoist these blocks will roll forward or backwards and out of the fixture. This will cause severe injury or death to operator.

The main bearing bores being used, should be on centerline of each support. Set the jacking bodies, with the proper length jack screw installed onto the machine base. These should be located in the general area of the supports. Temporarily secure to the deck with at least one bolt.

Lower the block down onto the supports. Place a level on the deck of the engine block and check the level front to back. Position the jack stands in a location to properly support the block and secure. To level, use the jacking screws to raise or lower the front of the engine block.

Position the block clamps on the machine bed and secure in a location to allow proper clamping.

The following illustration shows the correct triangle clamping system that should be used.

### Triangle Clamping

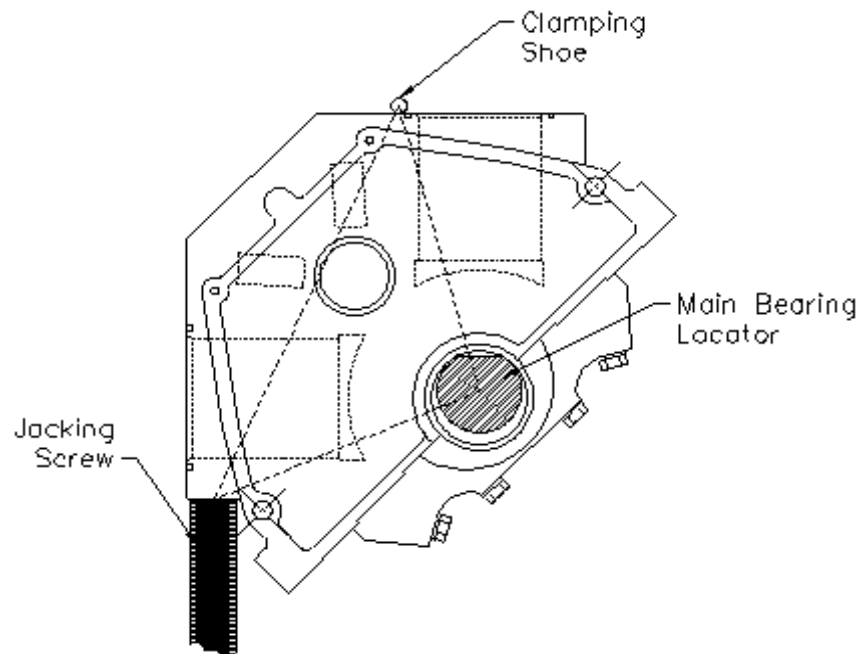

Adjust the height so the shoes rest on the clamp points. Tighten the clamp leg handles. Actuate the clamp shoes by turning their knobs. Apply pressure to the two clamps as evenly as possible to avoid tipping the block up on one side.

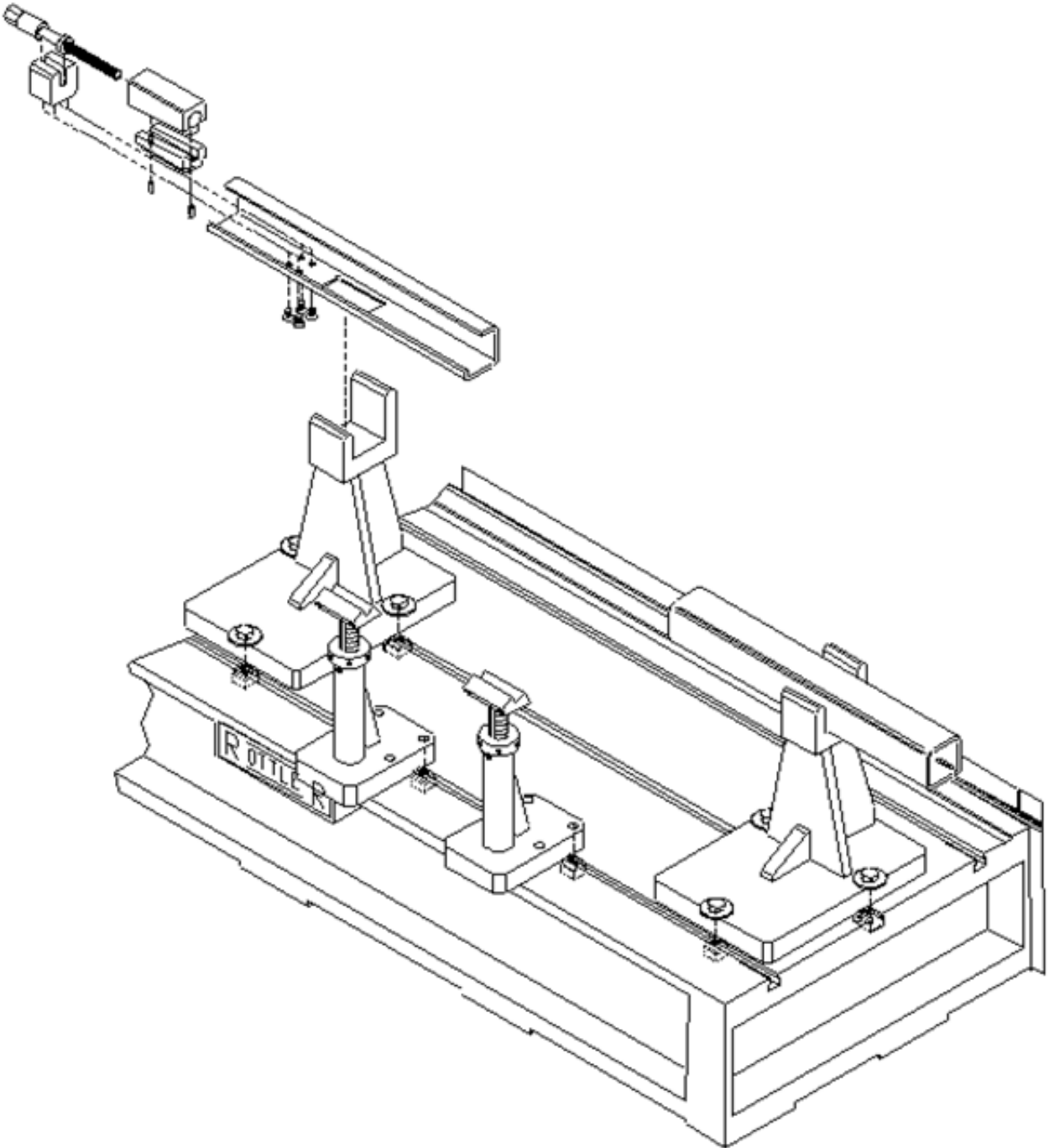

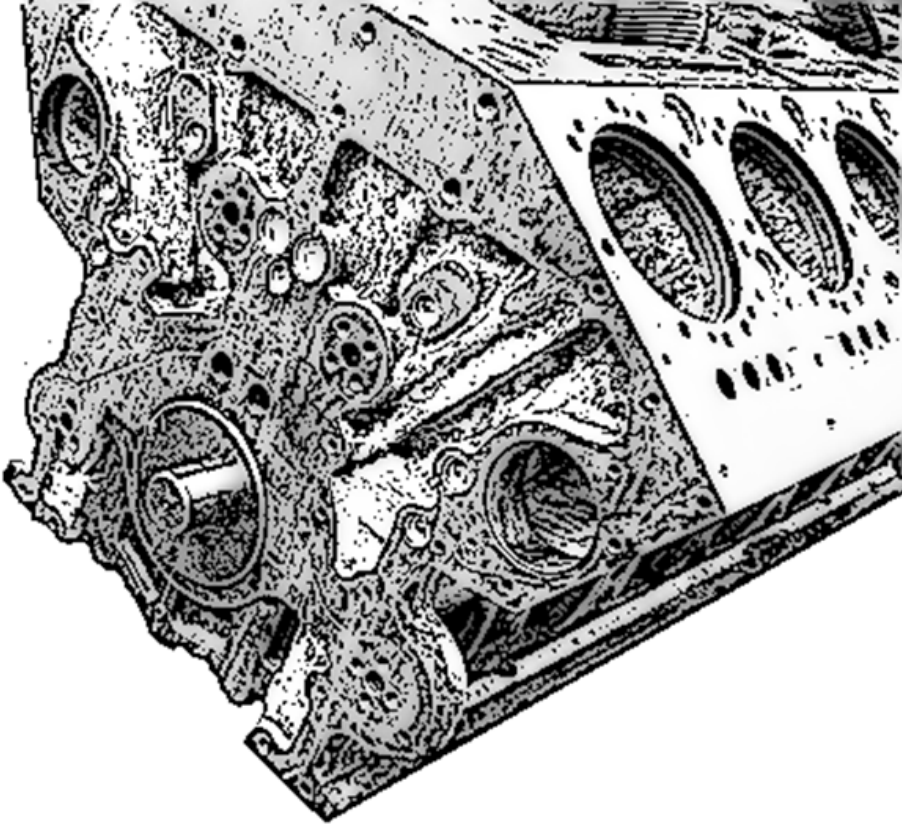

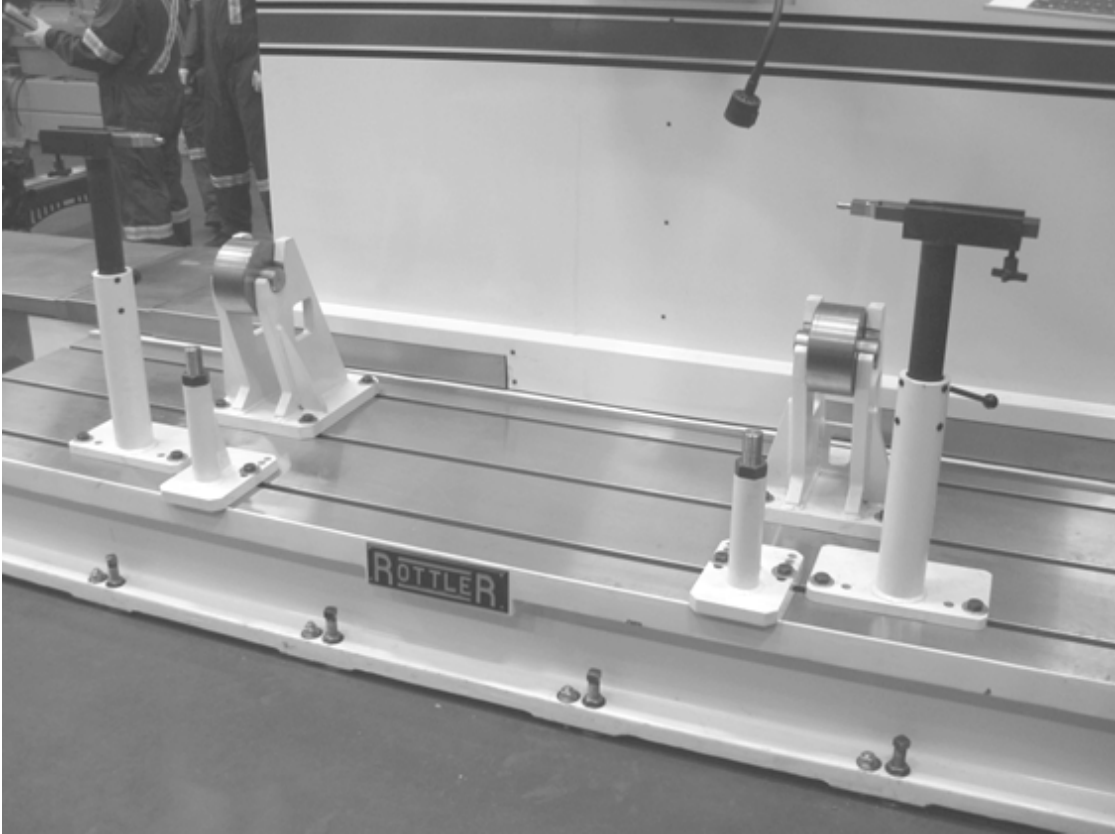



**6810 Waukesha 7042, 9390 and CAT 379, 398, 399 Block Line Bore Fixture**

This fixture is designed to be mounted directly on the bed of an F100 Series machine. Due to the large size of the Waukesha 7042 block, care must be taken when loading and unloading to avoid bumping the block into the column or spindle unit.

**⚠ WARNING** Handle these large blocks with Extreme care and guidance. A block hoist is required when handling these blocks.

Use the diagram on the following pages when referring to part numbers listed below. This Line Bore fixture consists of a stationary cradle and an adjustable support. The Cradle (6811A) is mounted to the machine bed over the locating pivot key and pin assembly. The locating pivot pin (6819) is pressed into the locating pivot key (6820). This assembly is positioned in the center keyway of the machine bed and the (2) set screws (MF-72) are tightened to lock the key in place. The Cradle is positioned over the pin and mounted to the machine bed. With the mounting bolts installed but not tight this provides a standard pivot point for the Cradle.

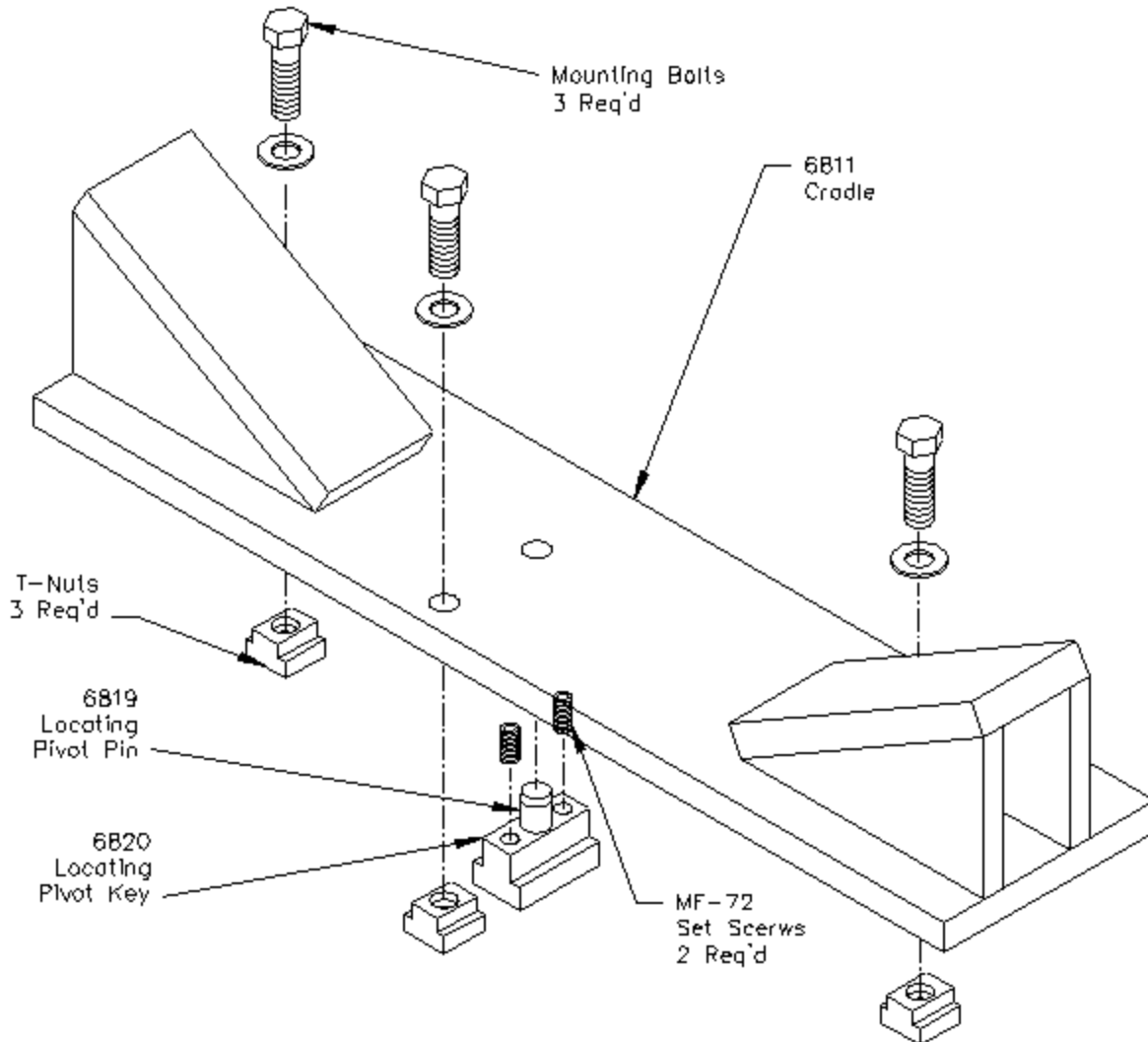

The support (6812A) is assembled with the adjusting screw (6754V) and the adjusting block (6814). This assembly is mounted to the machine bed with the lower tab of the adjusting block in the center keyway. ***Be sure to install the special ratchet adjusting wrench prior to setting this assembly on the machine bed***

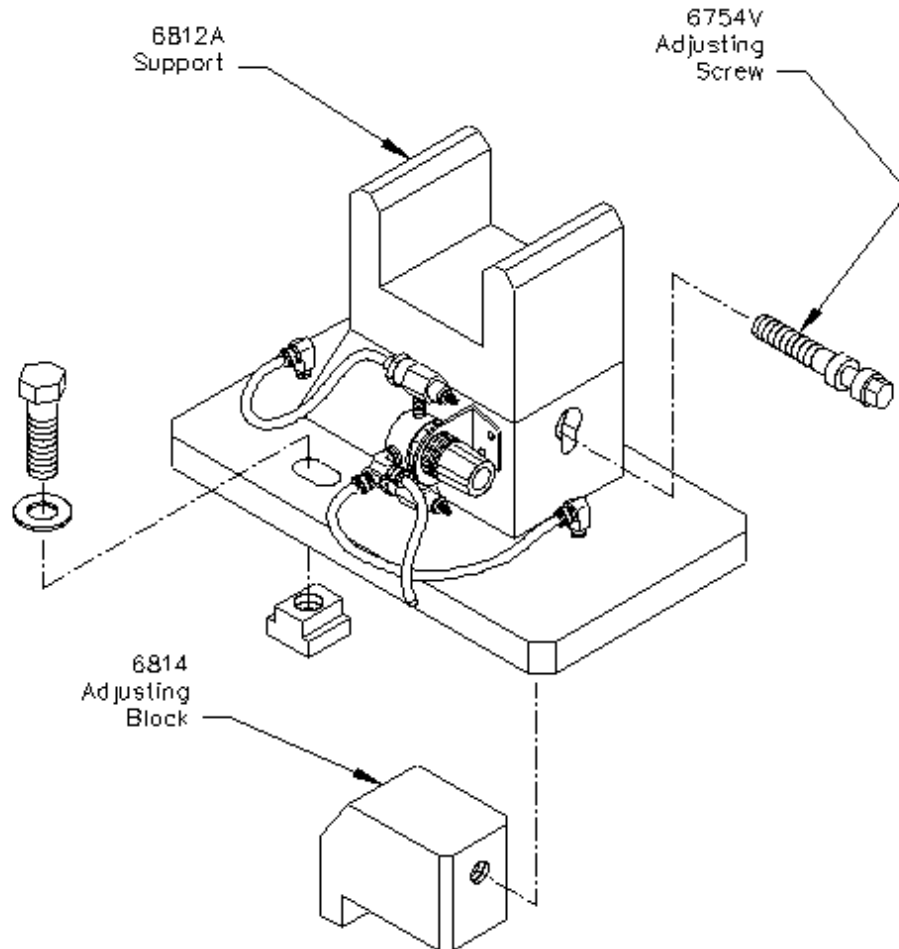

The adjustable tube (6813) is bolted to the Waukesha Block using the Cam Bearing Cap mounting holes. The adjustable tube has ten (10) holes drilled in it. Four (4) of the holes are used to bolt the adjustable tube to the engine block, the remaining six (6) holes are clearance for the cap alignment dowel pins in the engine block. Since the Cam Bearing Caps are not evenly spaced along the block, the adjustable tube must be mounted on the front end of the block as shown in the following illustration.



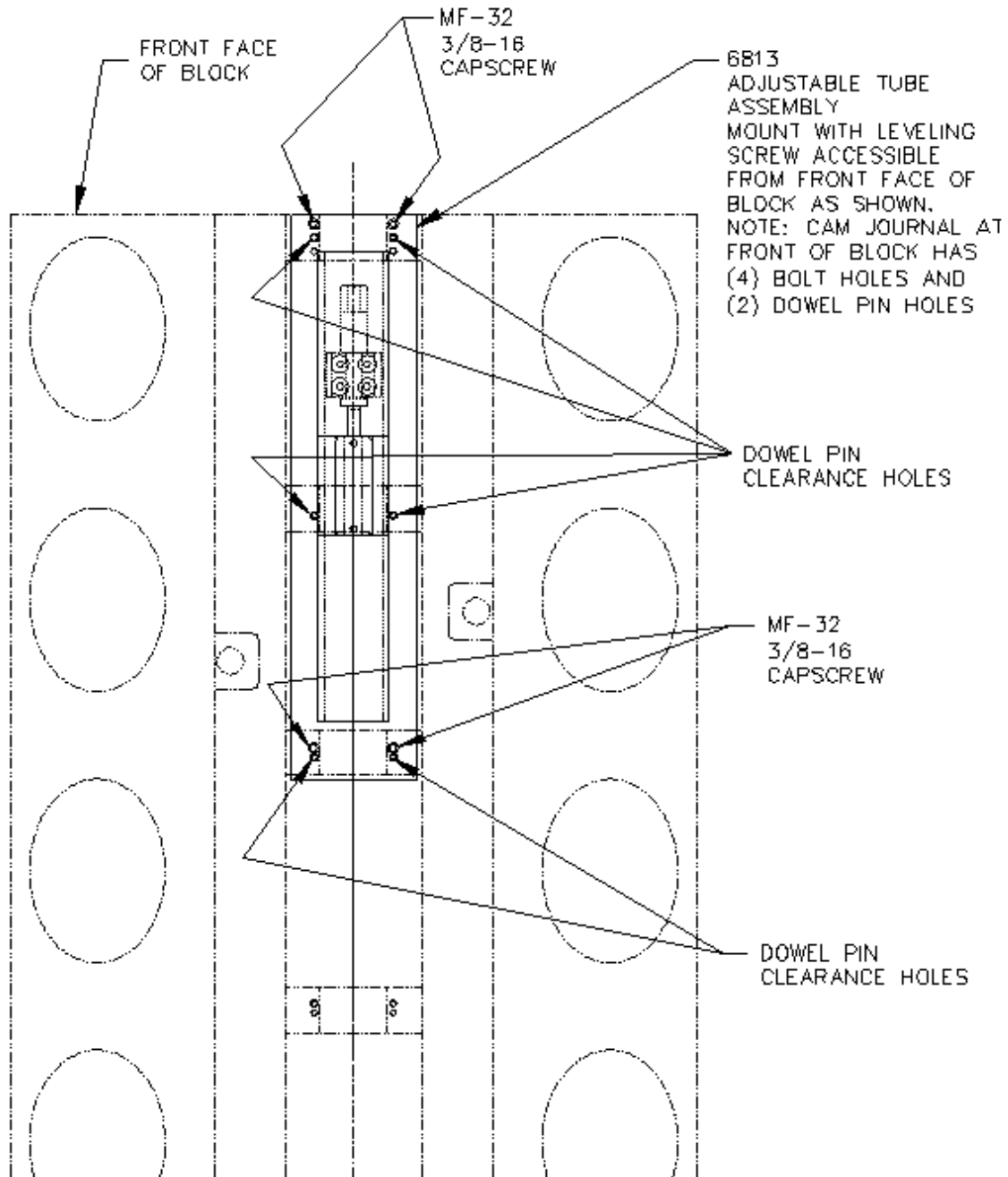

The upper and lower leveling pads, bracket and screw are already installed in the adjustable tube.

With the adjustable tube installed, the block is ready to be lowered into the Cradle and Support. Use caution to locate the adjustable tube correctly on the support. The two roll pins (MF-229B) installed in the lower leveling pad (6411) are designed to locate the leveling pads properly.

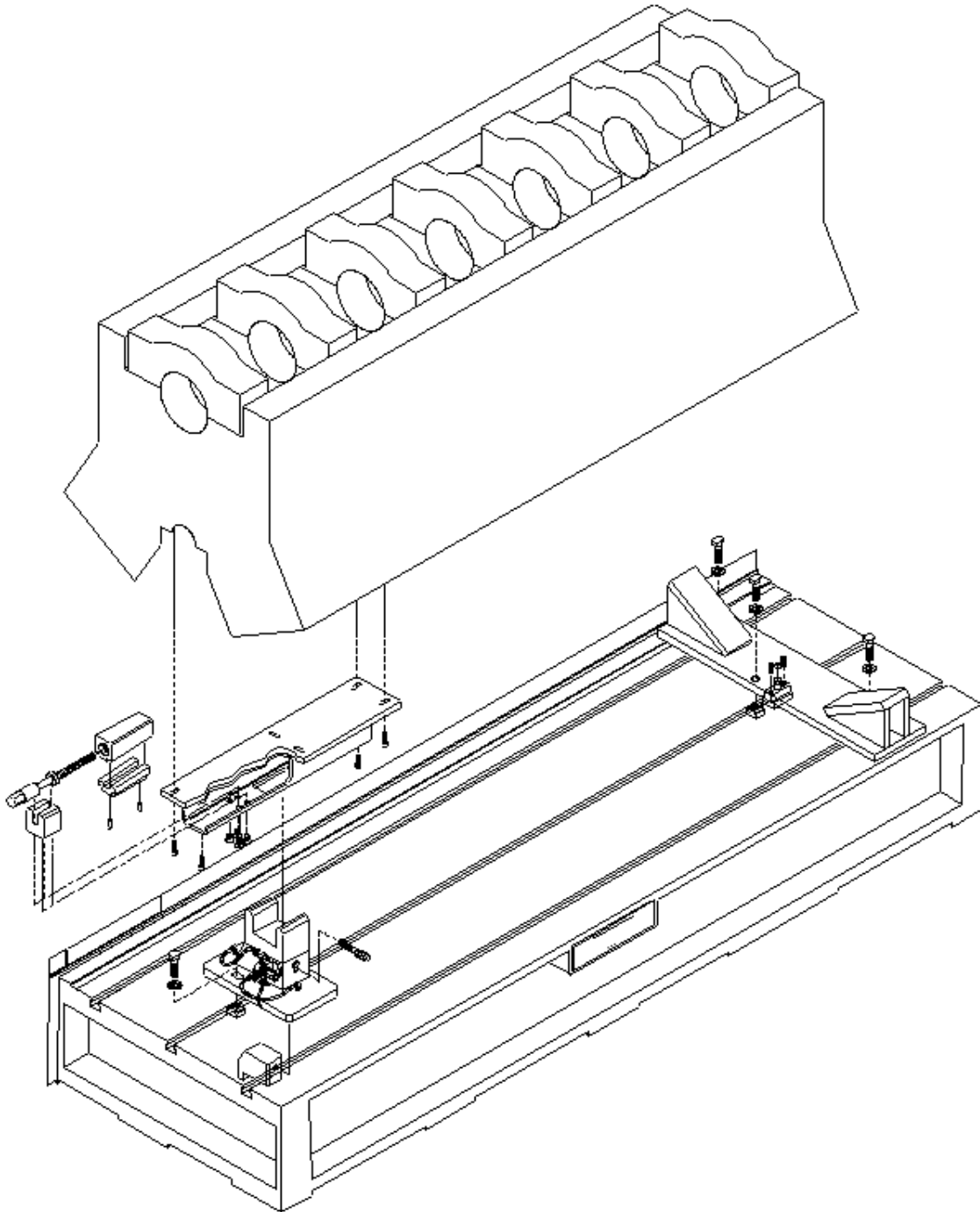

All mounting bolts should be loose to start with. Due to the design of this fixture the Cradle end of the block is stationary both in relationship to the machine bed key way and in height. This end is not adjustable. The adjustable end of the fixture is located on the same machine bed keyway as the cradle. Once the block is loaded into the fixture it is ready to be aligned for the line boring operation. Up and down adjustment is accomplished using the leveling screw (6408) inside the adjustable tube. The block is adjusted in and out by activating the air float on the support, and turning the adjustment screw using the previously installed ratchet wrench. Once the block is located in and out deactivate the air float and tighten the support end mounting bolt to lock into place. Tighten the three (3) mounting bolts on the Cradle end of the fixture now. The alignment of the block should be checked again at this time. Repeat alignment adjustments as needed.

## 6821 Adjustable, Universal Line Bore Parallel Assembly

This fixture is designed to be mounted directly on the bed of the F90 series machine.

Due to the large size of these blocks, care must be taken when loading and unloading to avoid bumping the block into the column or spindle unit.

**WARNING** Handle these large blocks with Extreme care and guidance. A block hoist is required when handling these blocks.

Use diagrams on the following pages when referring to part numbers listed below. This Line Bore fixture consists of a stationary parallel and an adjustable parallel used in conjunction with a cradle that fits the block to be machined.

Install the 6820 Pivot Key (with Pivot Pin already pressed in) into the center keyway on the right hand side of the F90 bed. Tighten the two MF-72 set screws down. This will hold the Pivot key in place while the parallel pivots on the Pivot Pin (6819). Place the parallel onto the pivot pin, install the mounting bolts and washers but do not tighten down.

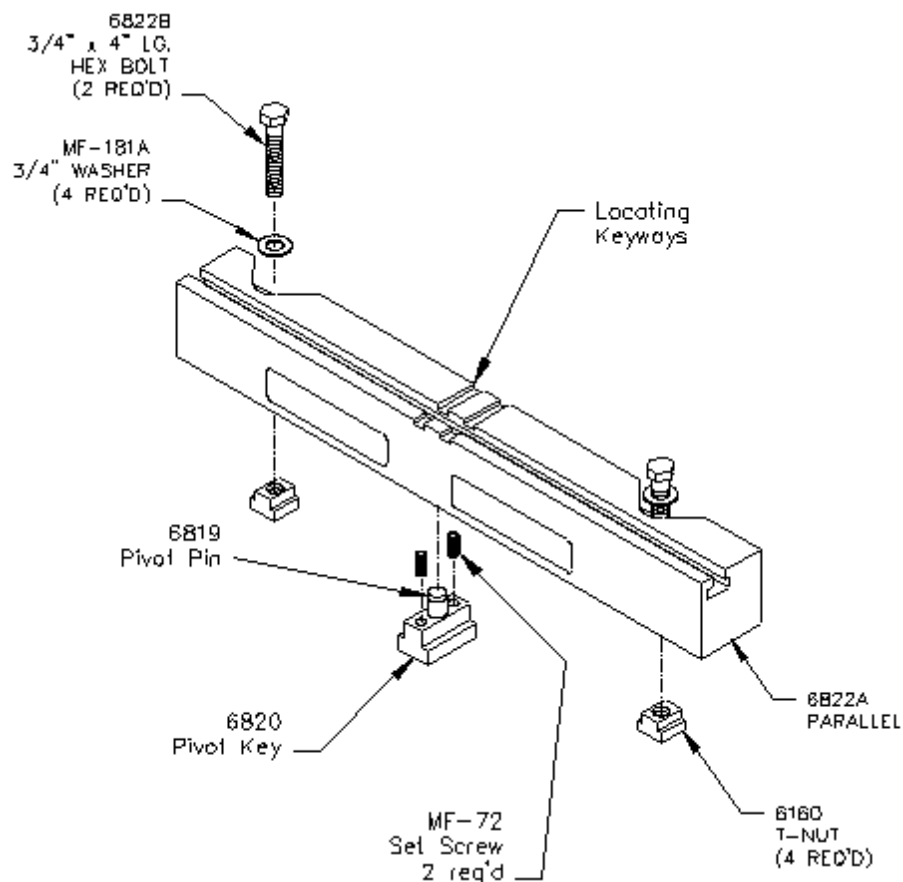

Install the adjustable parallel onto the left hand side of the F90 machine bed with the In/Out adjusting block (6830) located in the front keyway. Install the mounting bolts and washers but do not tighten down.

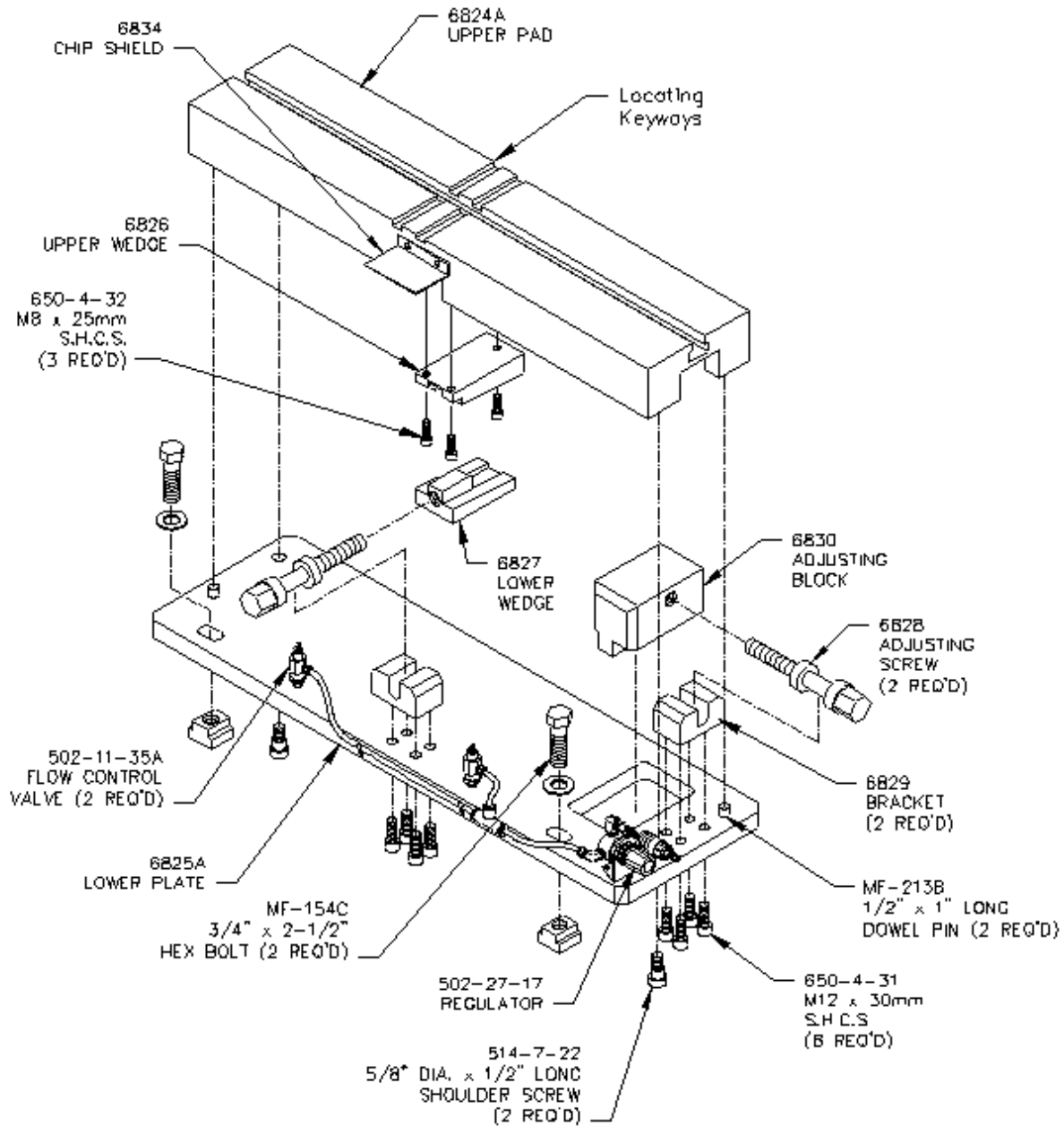

Once both parallels are installed on the machine bed, place a magnetic indicator on the spindle towards the main bed. Indicate the adjustable parallel into the stationary parallel to within .002" on the In/Out and height. This lines the fixture up close so the block can be loaded and then use minor adjustments on the fixture to line the block up.

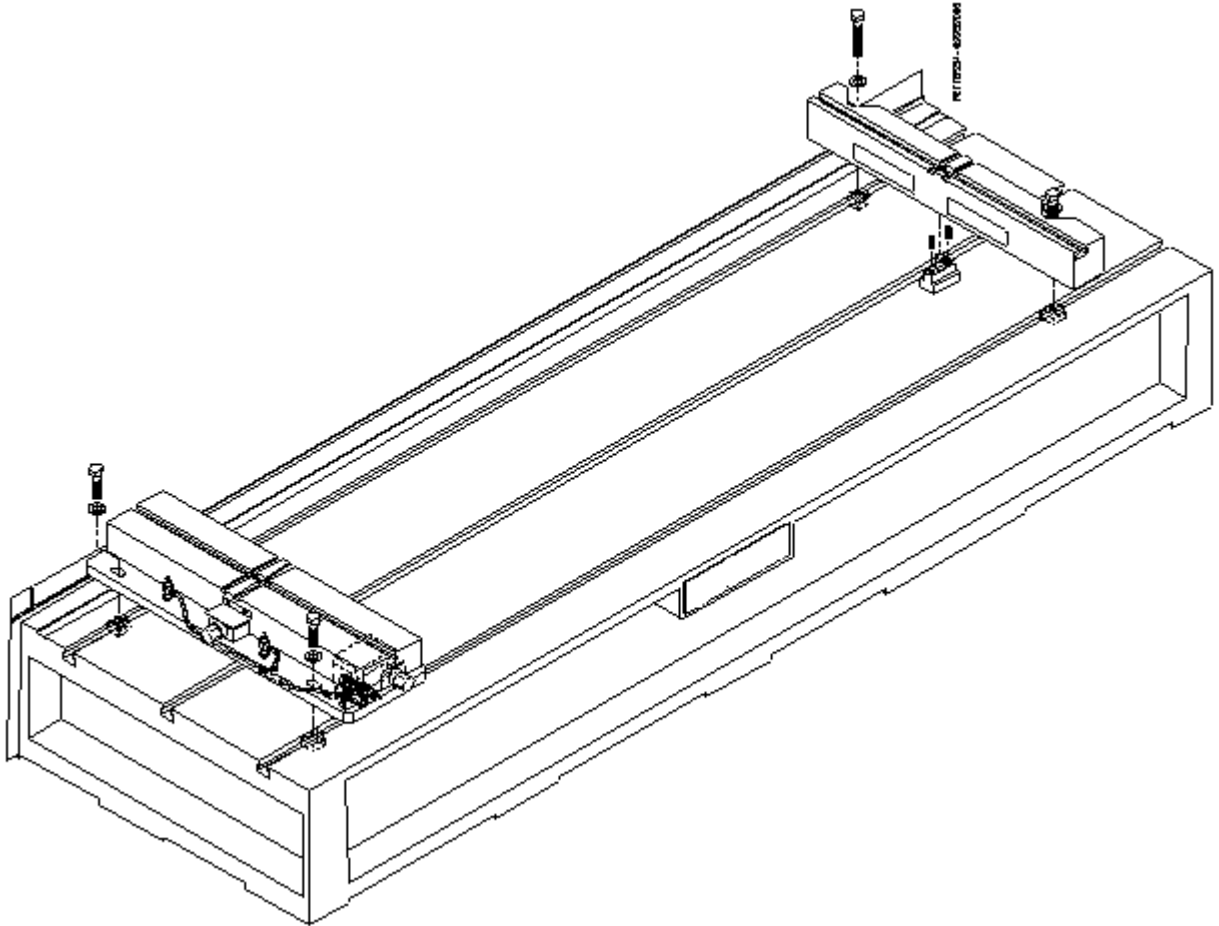

Select the set of V cradles for the block you are going to be machining. There are various types of cradles that can be used on this fixture. There are risers available also that can be mounted to the cradles to accommodate certain blocks. For cradle and riser selection refer to the Options section of this manual. The CAT 3500 series cradle is shown in this example.

Place the cradles on the parallel. Line up the horizontal key on the cradles with the key slot on the parallels. Generally, the rearward key slot is used, but on large blocks such as the CAT 3500, it is necessary to use the front key slot to allow clearance between the machine column, and engine block. Install mounting bolts and lock the cradles down. Due to the extreme weight of these blocks, clamping is usually not required. Threaded rods and clamp bars bridged across the cylinder bore, and threaded into the cradles is a way to secure the block if desired.

For in-line blocks, cradles are not used. In this case, round locators are bolted directly to the parallels. Lower the block with the end cylinders over the locators and push the block towards the front or rear. This will position the block in a straight line with the machine travel. Secure with threaded rods and clamp bars bridged across the cylinder bore, and threaded into the locators.

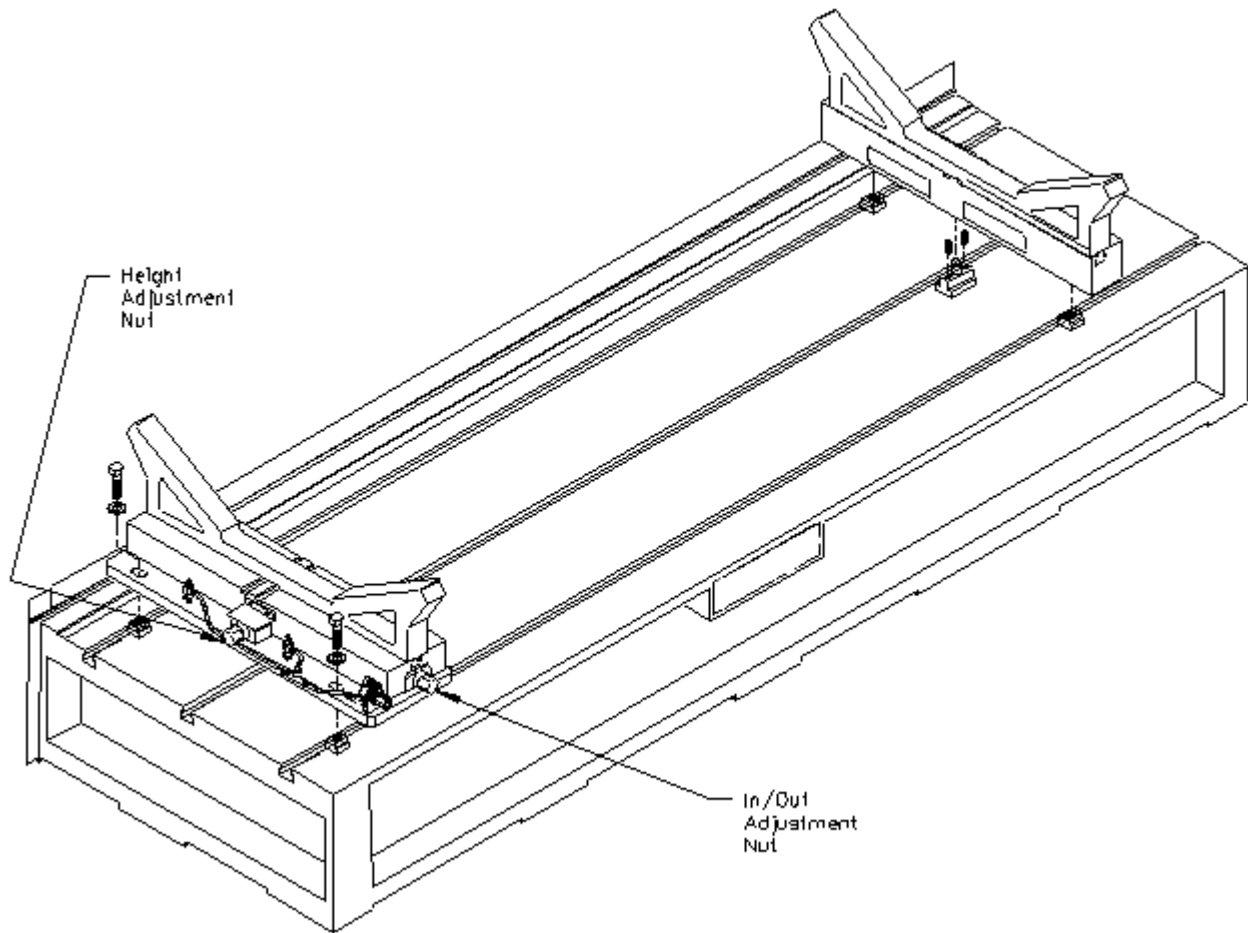

Lower the block slowly down into the cradles. Using a heavy soft mallet, tap the sides of the cradles to allow the block to settle into position. The block is now ready for alignment.

Up and down adjustment is accomplished by turning the screw on the side of the adjustable parallel. The in/out direction is adjusted by turning screw at the front of the adjustable parallel. Apply air pressure to the fixture while adjusting the in/out direction. Once the block is aligned, tighten down the fixture bolts and recheck alignment. Readjust as necessary.

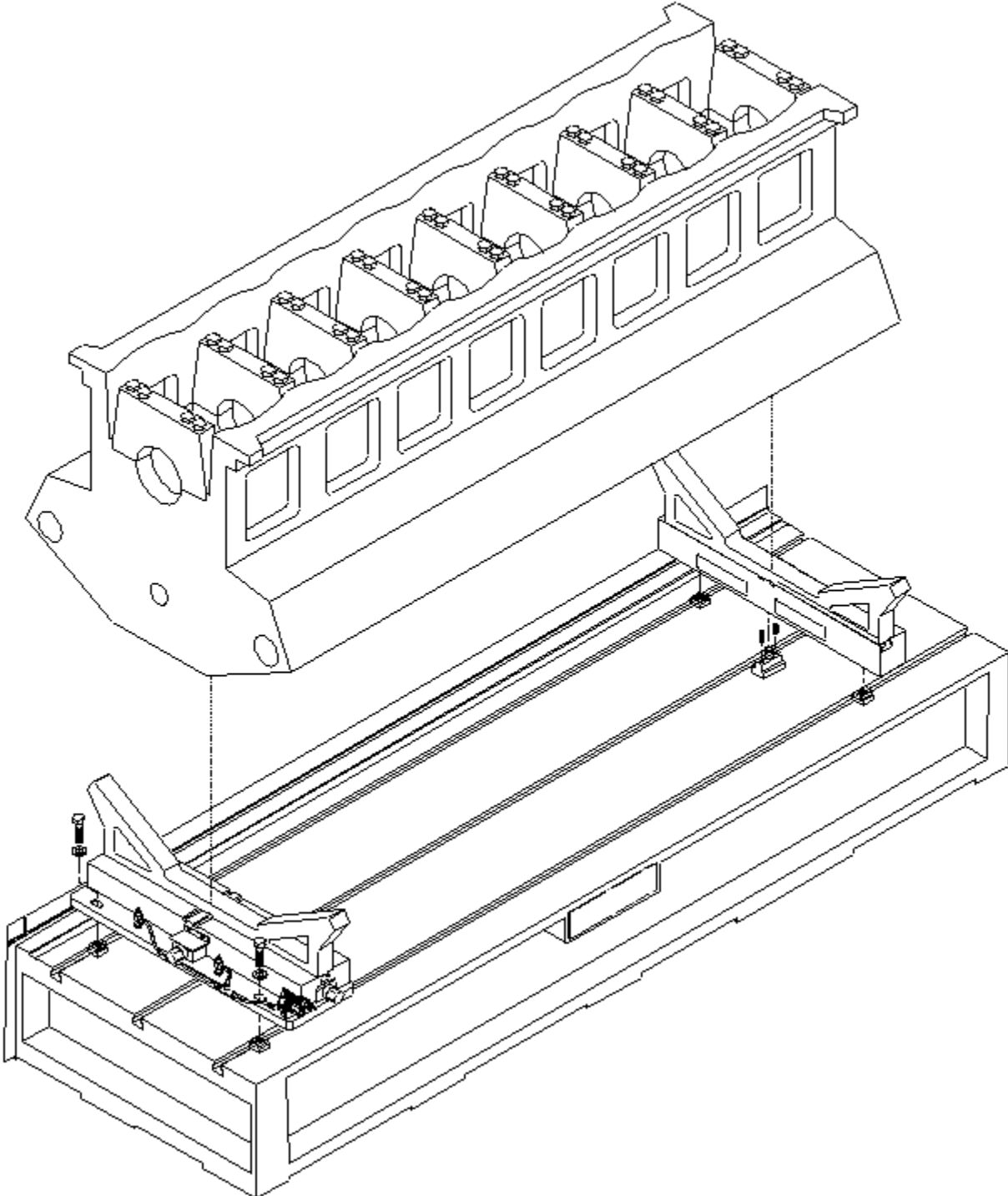

### 7119V Dual Axis Table Assembly

REFBUL90-120197

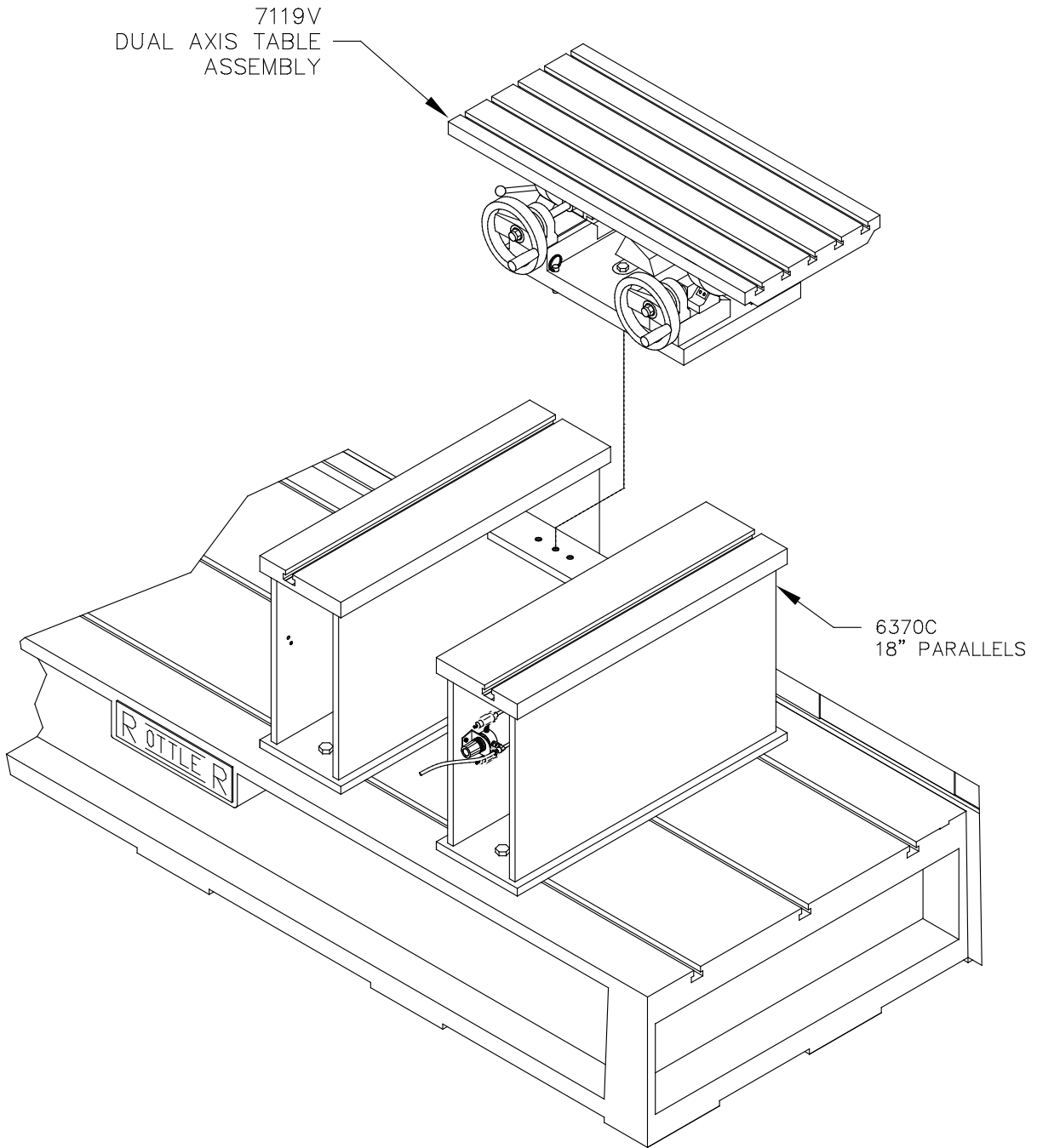



### Instructions for Small In-Line Blocks

The Dual Axis Table has the capability of holding small (less than 13 ½" from pan rail to head surface) in-line cylinder blocks for resurfacing. This will require the use of parts from the 7119P Universal Head Fixturing package.

### Mounting Block to Table

There are two (2) methods for mounting blocks to the Table. Blocks with the main caps removed or with the raised main bearings can be mounted directly to the table surface. Block with the main bearing caps installed which are lower than the pan rail surface must be mounted using support blocks from the Universal Fixturing package.

### Blocks with Main Caps Removed or Raised Main Bearings

Remove any burrs from pan rails of block.

Locate cone washers on table to approximately center block in path of cutter-head and 'hook' the edge of the pan rail in the rear. Clamp the block using clamp handle assembly. We suggest you install the stop rod assembly on the left hand end of the block. This is an added safety precaution.

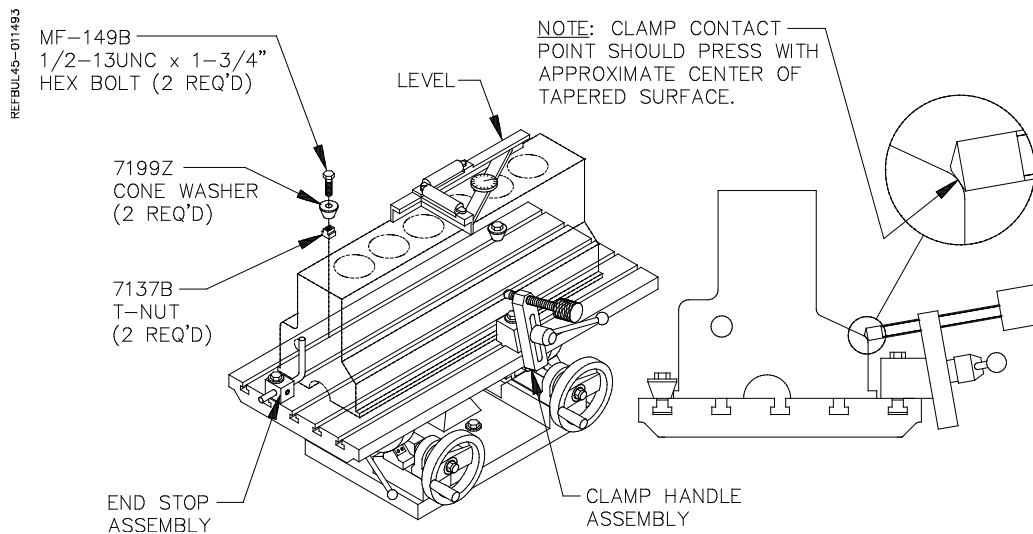

Check that all bolts and hold downs are tight. Loosen table clamp and level head surface of block in both directions. Lock table clamp and recheck block for level.

### Blocks with Main Caps Installed

Remove any burrs from pan rails of block.

Position rear supports and front supports to hold block approximately centered in path of cutter-head. Generally, place the front supports closer together than the rear supports.

Place the block on the supports. Reposition the supports if necessary to clear main caps. Etc. Elevate the cones to hook the pan rail in the rear. Tighten set screws to lock cones in place. Tighten the hex bolts on the supports. Adjust the support block jack to eliminate any rocking. Lightly apply the clamp handle assembly.

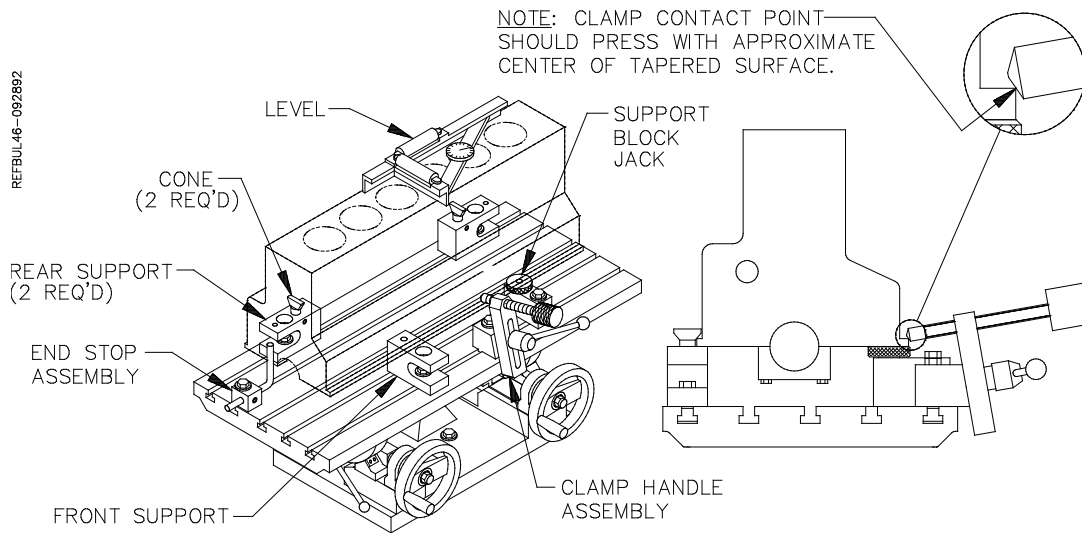

Loosen table clamp and level head surface of block in both directions. Lock table clamp. With the level still on the block tighten clamp handle assembly with appropriate clamp nose on the lower portion of a port or indent near the middle of the block. Tighten the clamp 1/8 to 1/4 turn after contacting the block. Do not over-tighten. Watch the level as you tighten to check for movement or warping. If the block moves or warps, repositioning the front supports inward will generally solve the problem. Check to see that the block cannot be moved in the fixture. We suggest that you install the stop rod assembly on the left hand end of the block. This is an added safety precaution.

### Typical Head Set Up Procedure

Find the desired ports or bosses, in the head, to position cones (long or short) on rear support blocks.  
 Measure the distance between the centerlines of these ports (bosses) within 1/16" (1mm – 5mm).  
 Measure the distance from rear support points to front support points on the head.

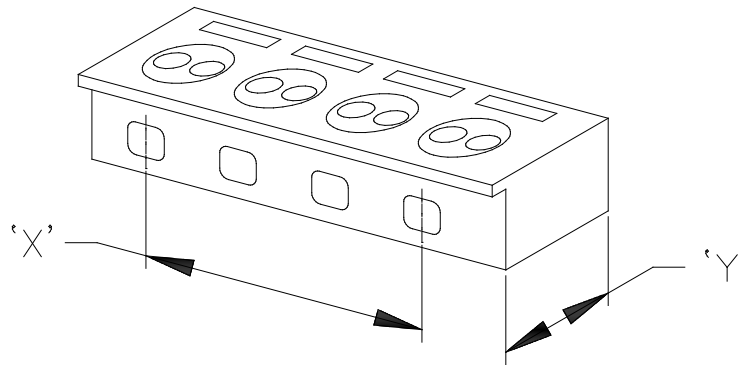

Position rear support blocks and front support blocks to hold the head approximately centered on the table top and spaced apart per dimensions measured in step '1' above. Generally, place the front blocks closer together than the rear blocks. If necessary, use either 2 or 4 spacers to raise the head for clearing studs or to angle the head so the cutterhead clears the head clamp handle assembly.

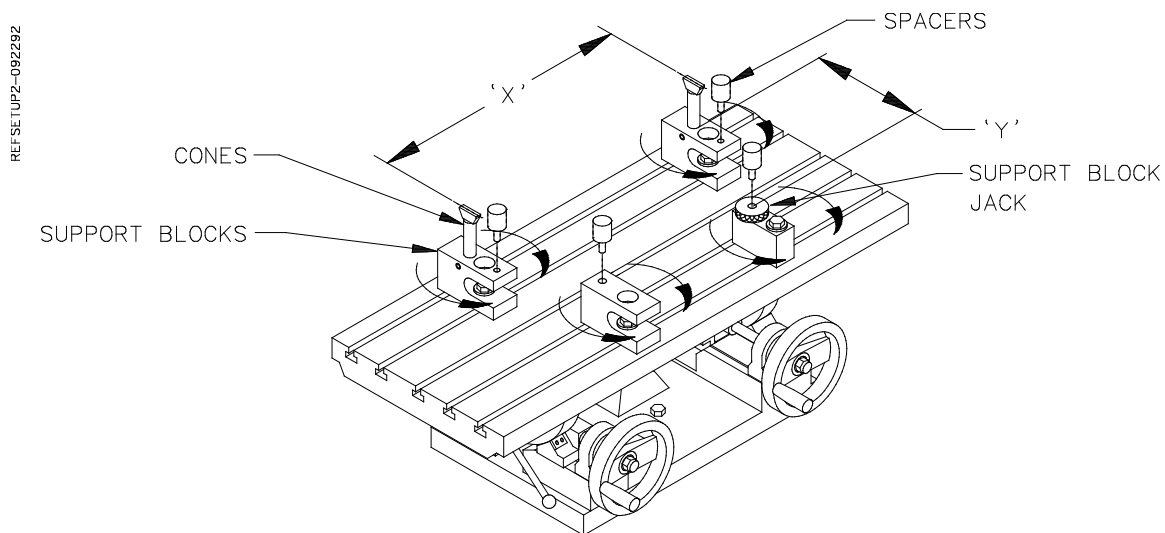

Place the head on the support blocks. Elevate the cones to 'hook' the two ports (bosses) on the head and tighten their set-screws. Adjust the position of the front support blocks if necessary. Tighten the hex bolts on the support blocks. Push the head back firmly into the cones. Adjust the support block jack to eliminate any rocking of the head. Do not tighten the head clamp handle assembly yet.

Unlock the table. Using the two hand-wheels, level the head surface to be cut. Lock the table in this position.

REFSETUP3-092292

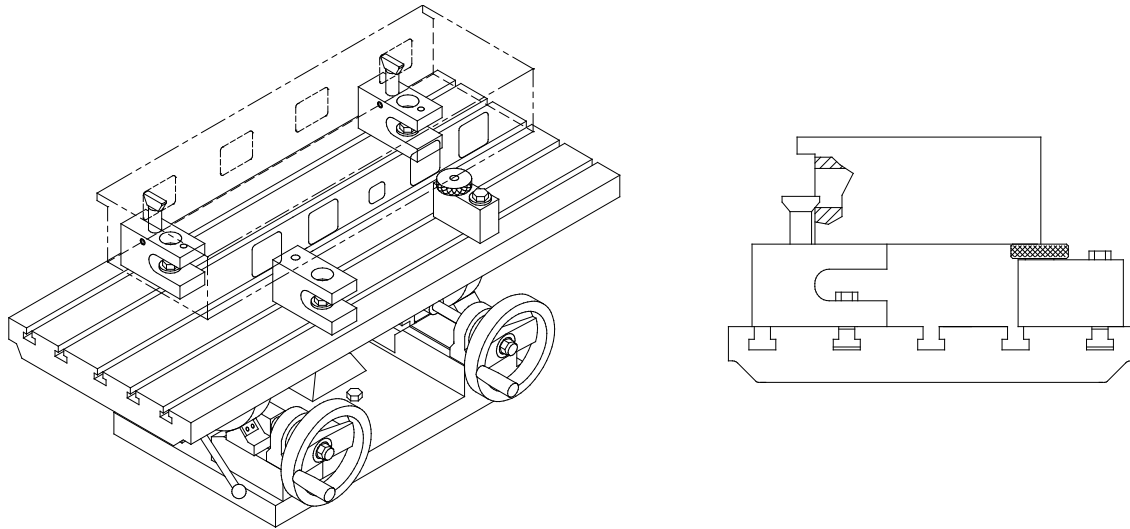

The head clamp handle assembly has a replaceable nose that pushes on the head. With the level still on the head surface, tighten the head clamp handle assembly on the lower edge of a port or indent near the middle of the head. Tighten the clamp 1/8 to 1/4 turn after contacting the head. Do not over tighten. Watch the level as you tighten to check for movement or warping. Some heads are very sensitive to support block placement, and the front support blocks may have to be moved slightly inward to prevent this warping. Check to see that the head cannot be moved in the fixture.

Slide the end stop block up against the left end of the head towards the rear. If possible, rotate the stop rod to contact a machined area on the end of the head. This will aid in loading a run of similar heads.

REFSETUP4-123192

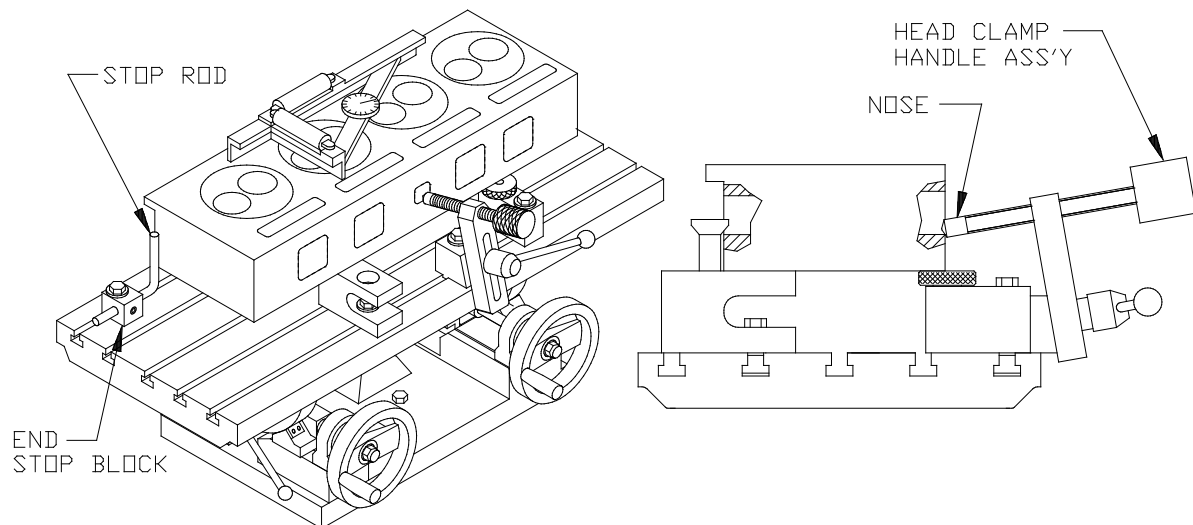

Visually check for clearance between the cutterhead and head fixture tooling pieces, especially the head clamp handle, assembly. The head should be approximately centered in the path of the cutterhead.

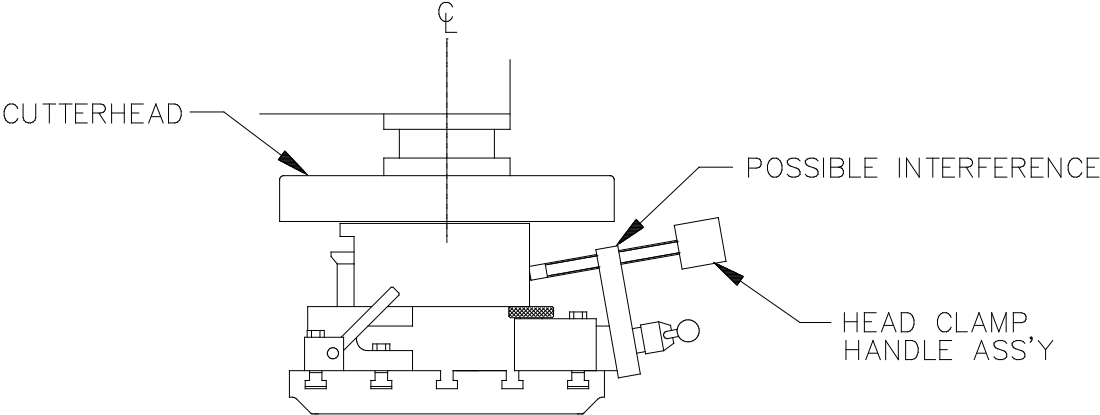

### **12” Multi Tooth Milling Head - 6865**

This milling head holds 14 insert cartridges. Each insert has 10 cutting edges, 5 on each side. The inserts need to be adjusted to be at equal height of each other to within .0004” (.01mm). To set the height of the inserts, install the milling head into the machine spindle. Install the inserts. Back off the small set screw above each tool cartridge. Loosen each tool cartridge, push up, and re-tighten.

Using an indicator with a large diameter convex tip, find the insert that is at the lowest setting. Now, adjust the remaining inserts to equal height by turning the small set screw above each tool cartridge.

There are a couple spindle motor parameters that need to be changed to gain more torque that this milling head requires.

Go to “Set up”, then “General Options”.

Find the line labeled “Spindle”.

Find the column labeled “Position Gain”, and change it to 10. (Record the original setting before changing)

Find the column labeled “Velocity Gain”, and change it to 600. (Record the original setting before changing)

100 to 120 RPM and a feed rate of .020”(.05mm) to .040”(1mm) is recommended. Maximum depth of cut .020”(.05mm)

When finish with the machining operation, re-enter the original spindle motor settings as recorded earlier.

### **18” Multi Tooth Milling Head 6864**

This milling head holds 9 insert cartridges. Each insert has 10 cutting edges, 5 on each side. The inserts need to be adjusted to be at equal height of each other to within .0004” (.01mm). To set the height of the inserts, install the milling head into the machine spindle. Install the inserts. Back off the small set screw above each tool cartridge. Loosen each tool cartridge, push up, and re-tighten.

Using an indicator with a large diameter convex tip, find the insert that is at the lowest setting. Now, adjust the remaining inserts to equal height by turning the small set screw above each tool cartridge. Install the dampener band around the perimeter of the milling head.

There are a couple spindle motor parameters that need to be changed to gain more torque that this milling head requires.

Go to “Set up”, then “General Options”.

Find the line labeled “Spindle”.

Find the column labeled “Position Gain”, and change it to 10. (Record the original setting before changing)

Find the column labeled “Velocity Gain”, and change it to 600. (Record the original setting before changing)

Find the column labeled “Accel Rate”, and change it to 2. (Record the original setting before changing)

70 to 90 RPM and a feed rate of .020”(.05mm) to .040”(1mm) is recommended. Limit the depth of cut to .001” (.025mm) to .002” (.05mm)

When finish with the machining operation, re-enter the original spindle motor settings as recorded earlier.

## General Machine Information

Before starting to build or use any of the Rottler operating programs it is important to understand how the machine operates internally.

The Rottler F103/4/5M model uses Computerized Numeric Control (CNC). The CNC is always operating when the machine is turned on. However, you will not see the CNC controls unless you switch over to the CNC operating screen.

## Homing

The F103/4/5M **MUST** be homed anytime it is turned off. If the machine has not been homed the reference positions for all programs will be off.

The purpose of Homing the machine is to set reference points in each axis for the machine to operate from. If the machine is not homed the reference points may be off position. The reference point is set in exactly the same position each time the machine is homed. The machine keeps track of these reference positions internally and the operator will not see them.

## Building Programs

NOTE: The instructions in this section are done WITHOUT using tool or Fixture offset values.

### Create a Block Program

Block Programs are listed on the left hand side of the screen. Mode programs that are for a specific Block Model are listed on the right side of the screen.

#### New

From the Program Select screen select New from the Left hand menu. This will open a window where will enter the Block name and configuration i.e. V6, V8 or Inline and number of cylinders.

NOTE: There is an existing program on start-up of new software called Part Program. This can be deleted after the first Block Program is entered.

Program Selected: Default Block      0.000 Vert 0.0000 In/Out 0.0000  
 Mode Selected: CL      1.00 Horiz 0.0000 4th 0.000

Program Selected:	Default Block	0.000	Vert	0.0000	In/Out	0.0000
Mode Selected:	CL	1.00	Horiz	0.0000	4th	0.000

Home    FIXTURE SELECT    TABLE OF TOOLS    Setup Software    Setup Electronics  
 Mode Select  
 Select    New    Std Setup  
 Options    Delete

Name	# Cyls	Config
Default Block	8	VBlock

New Block Options Window  
 Block Name: Chevy 350  
 Number of Cylinders: 8  
 Block Configuration: VBlock  
 OK    Cancel

#### Options

If you need to change the block configuration or name of a block that has already been created, use the Options button. This will bring up the same window as when the block was created.

### Creating Operating Modes for a Block Model

Select the Block model on the left hand side of the screen.

#### New

Selecting New will bring up a window that lists all the Modes that can be performed on the selected block model. Highlight the Mode you want to create and press OK.



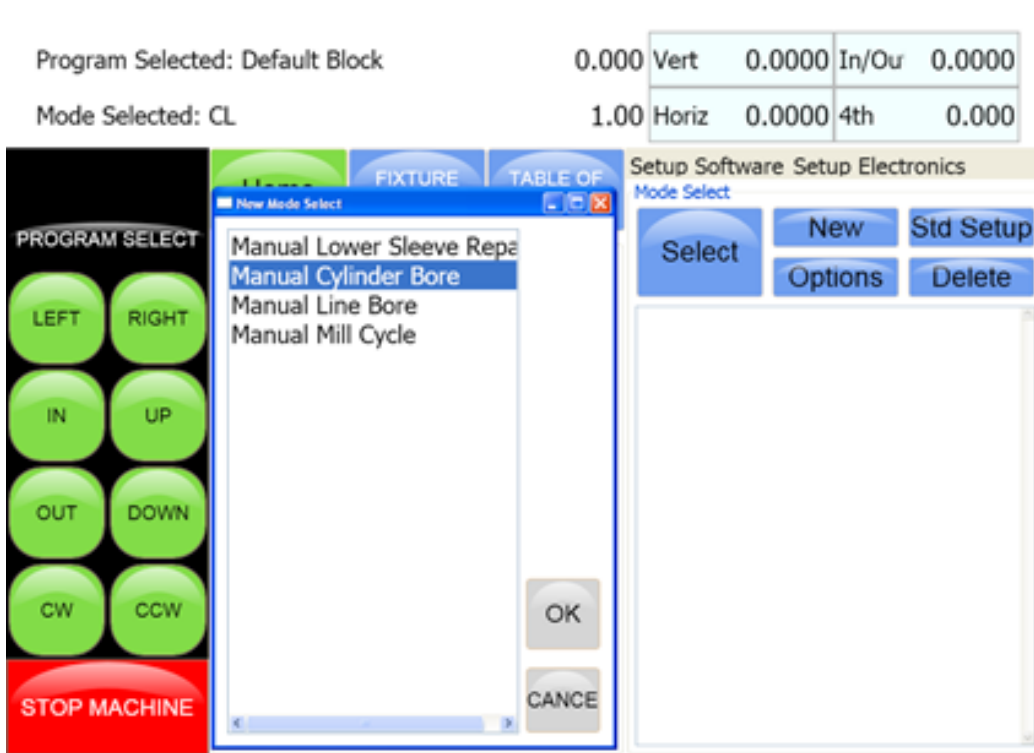

The selected mode will show up on the right hand side of the screen.

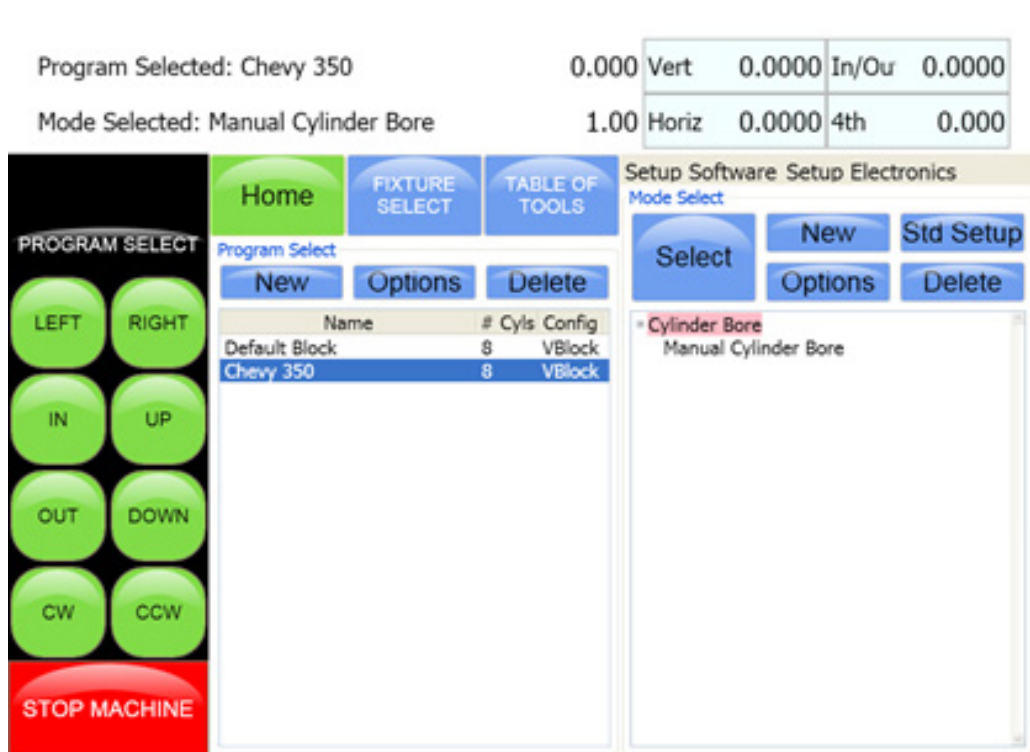

## Std (Standard) Setup

Pressing Std Setup will cause all of the available Modes to be inserted into the Modes area on the right hand side.



### Select

Pressing Select with a Mode highlighted will open the operations screens for using the program.

### Options

Pressing the Options button with a Mode highlighted will open a window where you can change the mode name. There is also a check box to allow positive number to be entered into the program where they are normally forced to a negative value.

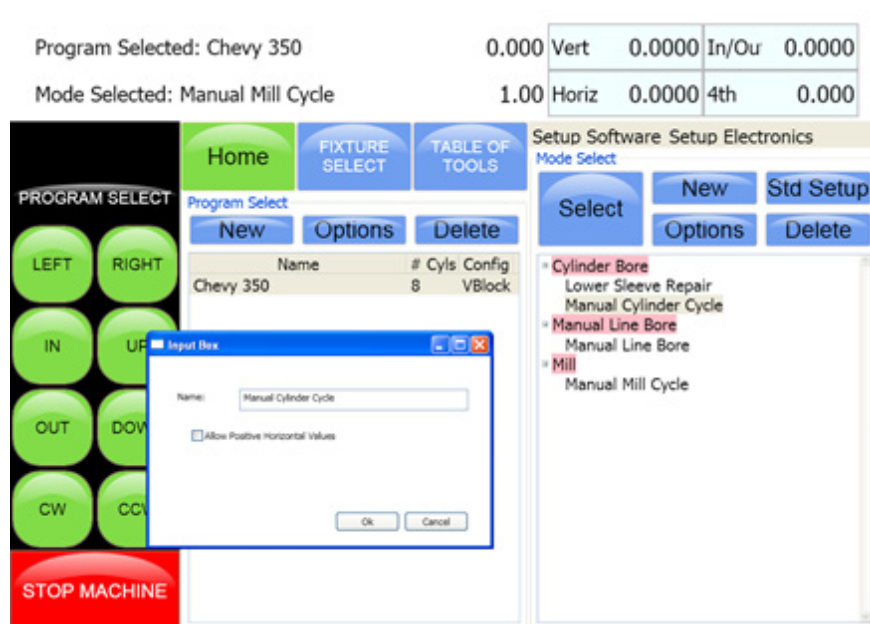

### Manual Cylinder Bore

Select Cylinder Bore and then Rough Through Bore on the screen. This will bring up the boring program with the Set Zeros tab shown.

NOTE: Once a certain feature is discussed in a particular mode it will not be discussed again in the following modes.

Program Selected: Chevy 350      0.000 Vert 0.0000 In/Out 0.0000  
 Mode Selected: Manual Cylinder Cycle      1.00 Horiz 0.0000 4th 0.000

Zero	Actual Position	Handwheel	Move To	Tool #:
VERTICAL	0.0000	.010 .001 .0001	MoveTo	N/A
HORIZONTAL	0.0000	.010 .001 .0001	MoveTo	Set Active
IN/OUT	0.0000	.010 .001 .0001	MoveTo	
SPINDLE	0.00	10x Coarse Fine	MoveTo	Probe #: N/A

Spindle Load 0.0%  
 Feed Rate 0.0020  
 Spindle RPM 400

PROGRAM SELECT  
 LEFT RIGHT  
 IN UP  
 OUT DOWN  
 CW CCW  
 STOP MACHINE

Set Zeros      Operation

MOVE TO ZEROS  
 CW INDEX CCW INDEX  
 START SPINDLE  
 PROBE AUTO CENTER

### Setting Zeros

The purpose of setting zero points is to give the operator a specific point to build programs from. The machine also uses these zero points to run the program from. The zero points can be set at any point in the machines' travel. Each axis (except the Spindle rotation) will need to have a zero point set for the machine to operate from. Every program will save its individual zero positions. The next time that program is selected the zero position will be the exact same distance from the Home position for each axis.

#### Horizontal and In/Out Zero

The machine will start the Auto Cycle at the Horizontal and In/Out zero position.

#### Vertical Zero

The machine will start the Auto Cycle from the Vertical zero position. You need to set the vertical zero with the cutting tool just above the work piece.

## Operation

Program Selected: Chevy 350	0.000	Vert	0.0000	In/Out	0.0000
Mode Selected: Manual Cylinder Cycle	1.00	Horiz	0.0000	4th	0.000

Set Zeros		Operation	
PROGRAM SELECT		DEPTHS	
LEFT	RIGHT	Bottom of Bore	-4.5000 <input type="button" value="SET"/>
IN	UP	<input type="checkbox"/> Stop and Index Spindle After Cycle	
OUT	DOWN	DWELL OPTIONS	
CW	CCW	Finish RPMS	60.00
<input type="button" value="STOP MACHINE"/>		Finish Revolutions	2.00
		<input type="button" value="START AUTO CYCLE"/>	

### Bottom of the Bore

This is the distance below zero or the Block deck where you want the machine to stop boring and retract out of the cylinder. When the spindle retracts it will then go to the block Clearance position.

### Stop and Index Spindle after Cycle

Checking this box will cause the spindle to be indexed to the three O'clock position after the cylinder has been bored but before it retracts. It will also offset to the left before the tool is retracted. This is the default setting. You would not want this check in an operation such as Lifter Boring.

### Finish RPMS and Revolutions

This is the RPM the spindle will turn for the set number of revolutions at the bottom of the bore. This is used to get a desired finish on a counter bore or sleeve cut.

### Start Auto Cycle

Pressing this button will start the automatic cycle. Spindle will travel vertically to the zero position. Horizontal and In/Out will then travel to the Zero position. The spindle will start at the programmed RPM on the Set Zeros page and then feed down at the programmed Feed Rate to the Bottom of Bore Setting.

## Manual Lower Sleeve Repair

Program Selected: 3500 CAT	0.000	Vert	0.0000	In/Out	0.0000
Mode Selected: Manual Lower Sleeve R	1.00	Horiz	0.0000	4th	0.000

Set Zeros		Operation	
<b>PROGRAM SELECT</b>			
LEFT	RIGHT		
IN	UP		
OUT	DOWN		
CW	CCW		
<b>STOP MACHINE</b>			
<b>DEPTHS</b>		<b>DWELL OPTIONS</b>	
Start Boring Height	-6.2800	Finish RPMS	60.00
Bottom of Bore	-6.4000	Finish Revolutions	2.00
Horz Clearance	-0.1000		
Horz Overshoot	0.0200		
<input type="checkbox"/> Stop and Index Spindle After Cycle			
		<b>START AUTO CYCLE</b>	

### Start Boring Height

This should be set to a value just above the where the cut will start. The Vertical Zero should be set with the cutting tool even with the block deck.

### Horz Clearance

This is the amount the machine must offset horizontally for the tool to clear the upper bore.

### Horz Overshoot

This is the distance for the machine to move past the Horizontal Zero when coming back from the Horizontal Clearance distance at the Start Boring position.

### Bottom of Bore

Set this value to where you want the cut to end. This is a vertical position referencing the Vertical Zero.

### Start Auto Cycle

Pressing this button will start the automatic cycle. Spindle will travel vertically to the zero position. Horizontal and In/Out will then travel to the Zero position. The Horizontal will then offset the programmed amount and direction. The vertical will then travel down to the Start boring height. The Horizontal will move back to the zero position plus the offset amount and then back to zero. This will remove any backlash. The spindle will start and then bore the programmed Bottom of Bore setting. The Horizontal will then offset the programmed amount and direction and then retract to the Vertical Zero location.

## Manual Line Bore

You will manually center the Vertical, Horizontal and In/Out on the center of the bore to be line bored.

Program Selected: 3500 CAT      0.000 Vert   0.0000 In/Out   0.0000

Mode Selected: Manual Line Bore      1.00 Horiz   0.0000 4th      0.000

0.000	Vert	0.0000	In/Out	0.0000
1.00	Horiz	0.0000	4th	0.000

**Set Zeros**      **Vertical Stops**

PROGRAM SELECT

LEFT      RIGHT

IN      UP

OUT      DOWN

CW      CCW

STOP MACHINE

BORE PROFILE

Bore Length      1.5000

START AUTO CYCLE

### Bore Length

This is the Width of the bore.

### Start Auto Cycle

Pressing this button will start the spindle and feed rate set in the Set Zeros page. The spindle will bore horizontally to the programmed depth and direction then retract to the zero position.

## Manual Mill

Center the milling head on the work piece in the In/Out Direction and set the zero position. Horizontally position the Mill head just to the right of the work piece and zero. Set the Vertical Zero even with the work surface. Add the desired amount of material to be removed using the handwheel and re-zero the Vertical.

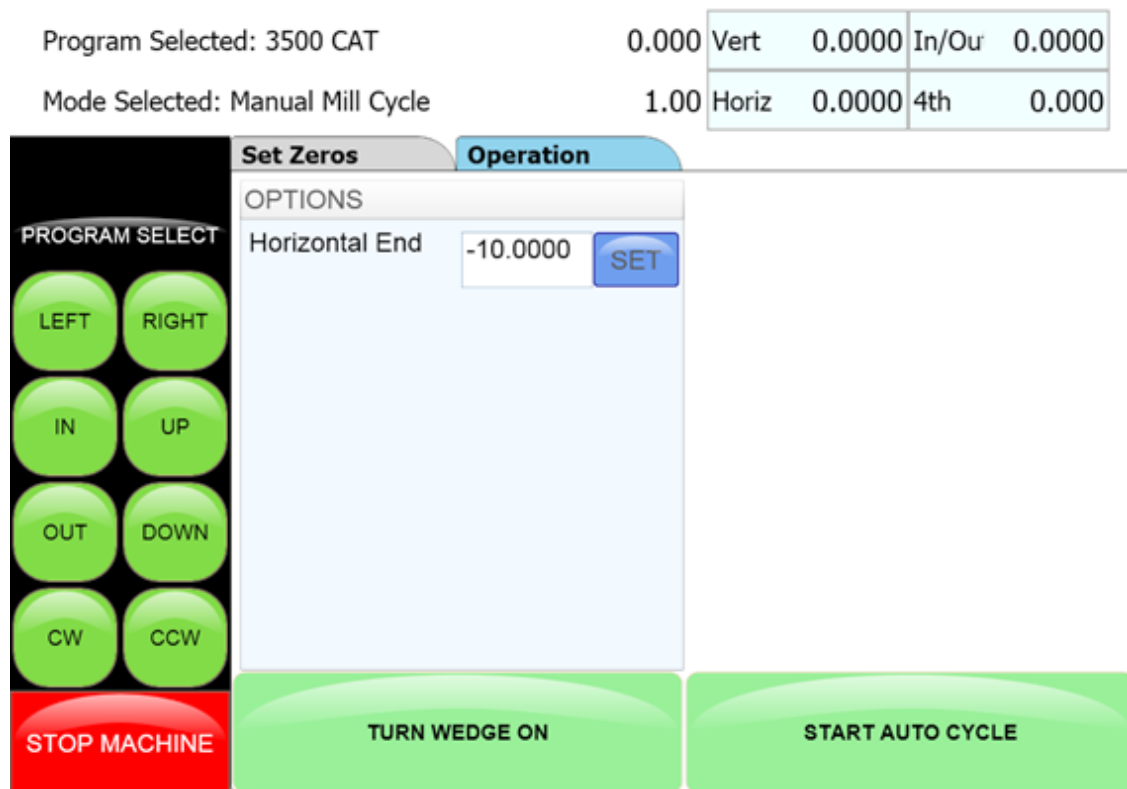

### Horizontal End

This is the length of horizontal travel that will be required to Mill the entire surface of the work piece.

### Start Auto Cycle

Pressing this button will start the automatic cycle. Spindle will travel vertically to the zero position. Horizontal and In/Out will then travel to the Zero position. The Spindle will start at the set RPM and Feed rate to the Horizontal End position.

This page intentionally left blank



# MAINTENANCE

## Contents

Quick Reference Lubrication Chart: F103/4/5M.....	6-1
Quick Reference Preventative Maintenance Chart: F103/4/5M .....	6-1
Grease Cross Reference Chart .....	6-2
<b>Maintenance.....</b>	<b>6-6</b>
<b>Lubrication .....</b>	<b>6-6</b>
Outer Spindle .....	6-6
Upper Belt Housing .....	6-6
Oil Reservoir System .....	6-7
Inner Spindle Bearings .....	6-7
Vertical Ballscrew Bearings.....	6-7
Priming Spindle Base Oil Lines .....	6-8
Lubrication Locations .....	6-9
Right Angle Drive Lubrication Information .....	6-11
Air Line Diagram.....	6-12
F103/4/5M Wiring Diagram.....	6-13
502-12-7B Sony LT20 Set Up Instructions.....	6-14
Changing between Inches and mm.....	6-14
Basic Settings .....	6-14
Spindle Drive Belt Replacement / Adjustment.....	6-15
Outer Spindle Bushing Adjustment.....	6-20
Upper Bushing Adjustment.....	6-21
Inner Spindle Adjustment .....	6-22
F103/4/5M Upper Housing Disassembly.....	6-26
F103/4/5M Inner Spindle Removal.....	6-29
Inner Spindle Angular Contact Bearing Replacement .....	6-29
Spindle Sweep .....	6-31
Horizontal Gibs .....	6-32
Adjusting Y-Axis Gibs .....	6-34

<b>Adjustment Procedure .....</b>	<b>6-35</b>
<b>Backlash Setting .NET Software .....</b>	<b>6-36</b>
<b>Spindle Belt Adjustment .....</b>	<b>6-45</b>
<b>Top and Side Rail Adjustment .....</b>	<b>6-46</b>
<b>Mill Tilt Adjustment Procedure .....</b>	<b>6-47</b>
<b>Checking Wear on Column Turcite Pads.....</b>	<b>6-49</b>
<b>Digital Micrometer setting instructions .....</b>	<b>6-51</b>
To set or edit micrometer .....	6-52
<b>Probe “On-Center” Adjustment.....</b>	<b>6-56</b>
<b>Ballscrew Assemblies Reference .....</b>	<b>6-57</b>
<b>Alignment Definitions for Angular Bearings and Belleville Washers .....</b>	<b>6-57</b>
Bearing Alignment .....	6-57
Belleville Washer Alignment .....	6-57
<b>Z-Axis Lower Bearing and Belleville Washer Stacking Order .....</b>	<b>6-58</b>
<b>Z-Axis Lower Bearing and Belleville Washer Section View.....</b>	<b>6-59</b>
<b>Z-Axis Upper Belleville Washer Stacking Order .....</b>	<b>6-60</b>
Z-Axis Upper Belleville Washer Section View .....	6-60
<b>X-Axis Drive Side Bearing Stacking Order.....</b>	<b>6-61</b>
X-Axis Drive Side Bearing Section View .....	6-61
<b>X-Axis Idle Side Bearing Stacking Order .....</b>	<b>6-62</b>
X-Axis Idle Side Bearing Section View.....	6-62
<b>Y-Axis Bearing Stacking Order .....</b>	<b>6-63</b>
Y-Axis Bearing Section View.....	6-63
<b>Inner Spindle Upper Section Belleville Washer Stacking Order .....</b>	<b>6-64</b>
Inner Spindle Upper Section Belleville Washer Section View .....	6-64
<b>Inner Spindle Lower Section Bearing Stacking Order .....</b>	<b>6-65</b>
<b>Inner Spindle Lower Section Bearing Section View.....</b>	<b>6-66</b>

**Quick Reference Lubrication Chart: F103/4/5M**

Refer to the maintenance section in the manual for lubrication location points and instruction.

Assembly	Frequency	Lube Operation	Recommended Lubricant	Date Serviced
Outer Spindle	8 Hours	Wipe with oil	ISO VG 68 Way Oil	
	1000 Hours	Soak felt wiper with oil		
Oil Reservoir System	8 Hours	Check upper oil lines are full	ISO VG 68 Way Oil	
	175 Hours	Fill reservoir with oil if needed		
Upper Vertical Ballscrew Pillow Block Bearing	175 Hours	Grease	NLGI 2 White Lithium Grease	
Lower Vertical Ballscrew Bearing Pack	175 Hours	Grease	NLGI 2 White Lithium Grease	
Rear Y Axis Bearing Housing Grease Fitting	175 Hours	Grease	NLGI 2 White Lithium Grease	
Column Feed Gear Housing	1000 Hours	Fill with oil	GL-5 or MT-1 80W-90 Gear Oil	

**Quick Reference Preventative Maintenance Chart: F103/4/5M**

Refer to the procedures in the maintenance section of the manual to make or check these adjustments. Not all of the items listed in the table below have adjustment. The information should be recorded and the amount of wear tracked so the part can be replaced before down time on the machine occurs.

Procedure	Frequency	Date Serviced/Comments
Spindle Sweep Adjustment	150 Hours	
Outer Spindle Bushing Adjustment	500 Hours	
Spindle Tilt Measurement	500 Hours	
Inner Spindle Bearing Adjustment	1000 Hours	
Horizontal Gib(s) Adjustment	1000 Hours	
X,Y,Z Auto Mode Backlash Adjustment	1000 Hours	
X,Y,Z Handwheel Backlash Adjustment	1000 Hours	
Electrical Enclosure Air Filter Replacement	1000 Hours	
Machine Level Adjustment	1000 Hours	
Spindle Drive Belt Adjustment	1000 Hours	
Vertical Drive Belt Adjustment	1000 Hours	
Horizontal Ballscrew Inspection	2000 Hours	
Spindle Wear Measurement	2000 Hours	
Horizontal Way Wear Measurement	2000 Hours	

Grease Cross Reference Chart

ISO AND UNII SYMBOLS	APPLICATION FIELD	Agip	api	ARAL	ARCO	barelli	bellini	BERGOLINE	BP	BRYTOL INDUSTRIAL OILS	Castrol	Chevron
AN 68	LUBRIFICAT. LOSS	RADULA 68 ACER 68	API MF-68	ARAL DURAL MR 68	GASCON 68	MIN 68	TRANSMISSION 68	ACCA 68	CS 68	CM 68	MAGNA 68	CIRCULATING OIL 68 GST OIL 68
CB 32	GEARS	ACER 32	API MF-32 API CIS-32	ARAL DURAL MR46 ARAL VITAM GF 32	RUBILENE 32	NITAO5 32	SPRINTER AS 32	BERGOLUID 32 PARATER S 32	ENERGOL CS 32	CMC 32	MAGNA 32 PERFECTO T32	CIRCULATING OIL 46 GST OIL 46
CB 68	MODERATELY CHARGED	ACER 68	API MF-68 API CIS-68	ARAL DURAL MR 68 ARAL VITAM GF 68	RUBILENE 68	NITAO5 68	SPRINTER AS 68	BERGOLUID 68 PARATER S 68	ENERGOL CS 32	CMC 68	MAGNA 68 PERFECTO T68	CIRCULATING OIL 68 GST OIL 68
CB 150		ACER 150	API MF-150 API CIS-150	ARAL DURAL MR 150 ARAL DEGOL TU 150	RUBILENE 150	NITAO5 150	SPRINTER AS 150	BERGOLUID 150 PARATER S 150	ENERGOL CS 150	CMC 150	MAGNA 150	CIRCULATING OIL 150 GST OIL 150
CC 150	GEARS VERY CHARGED	BLASIA 150	API DT-150	ARAL DEGOL BG 150	PENNANT NL 150	G.E.P. 150	RED R14 150	BERGOFLEP EP150	ENERGOL GR-XP 150	DENTOL EP 150	ALPHA SP 150	NL GEAR COMPOUND 150
CC 320		BLASIA 320	API DT-320	ARAL DEGOL BG 320	PENNANT NL 320	G.E.P. 320	RED R14 320	BERGOFLEP EP320	ENERGOL GR-XP 320	DENTOL EP 320	ALPHA SP 320	NL GEAR COMPOUND 320
CC 460		BLASIA 460	API DT-460	ARAL DEGOL BG 460	PENNANT NL 460	G.E.P. 460	RED R14 460	BERGOFLEP EP460	ENERGOL GR-XP 460	DENTOL EP 460	ALPHA SP 460	NL GEAR COMPOUND 460
FD 5	SPINDLES, BEARINGS AND COUPLED CLUTCHES	OSO 10		ARAL DURAL SR 5	DURO OIL 10	VELOS A 10	SPRINTER ADPV5	BERGOSPIN 5	ENERGOL HP 5	AROS 5	MAGNA AB 5	MECHANISMLPS 15
FD 10		OSO 10	API CIS-10	ARAL DURAL SR 10	DURO OIL 10	VELOS A 10	SPRINTER ADPV10	ENERGOL 10	ENERGOL HP 10	MOVIL 10	HYPSPIN AWS 10	
FD 22		OSO 15	API CIS-32	ARAL DURAL SR 22	DURO OIL 22	TIARO 22	SPRINTER ADPV22	BERGOSPIN 22	ENERGOL HLP-Z 22	MOVIL 22	HYPSPIN AWS 22	
G 32		EXIDIA 32	API MX-32		TRUSLIDE 32	TIARO BK 32	WAY 32	ENGINE K 32	ENERGOL GHL 32	VAITAK 32 AS 32	MAGNA CG 32	VISTAC OIL 32X
G 68		EXIDIA 68	API MX-68	ARAL DEGANIT B 68	TRUSLIDE 68	M.P. 68	WAY 68	ENGINE K 68	MACCOURAT 68 ENERGOL GHL 68	VAITAK 68 AS 68	MAGNA BD 68 MAGNA BDX 68	VISTAC OIL 68X
G 220		EXIDIA 220	API MX-220	ARAL DEGANIT B 220	TRUSLIDE 220	M.P. 220	WAY 220	ENGINE K 220	MACCOURAT 220 ENERGOL GHL 220	VAITAK 220 AS 220	MAGNA CF 220 MAGNA CFX 220	VISTAC OIL 220X
HM 32		OSO 32	API CIS-32	ARAL VITAM GF 32	DURO OIL AW 32	TIARO 32	SPRINTER ADPV 32	PARATER S 32 PARAVIS HLP 32	ENERGOL HLP-Z 32 HYDRO D 32	AROS 32 HYDRO D 32	HYPSPIN AWS 32	MECHANISMLPS 32
HM 46	HYDROSTATIC SYSTEMS	OSO 46	API CIS-46	ARAL VITAM GF 46	DURO OIL AW 46	TIARO 46	SPRINTER ADPV 46	PARATER S 46 PARAVIS HLP 46	ENERGOL HLP-Z 46 HYDRO D 46	AROS 46 HYDRO D 46	HYPSPIN AWS 46	MECHANISMLPS 46
HM 68		OSO 68	API CIS-68	ARALVITAM GF68	DURO OIL AW 68	TIARO 68	SPRINTER ADPV 68	PARATER S 68 PARATER HLP 68	ENERGOL HLP-Z 68 HYDRO D 68	AROS 68 HYDRO D 68	HYPSPIN AWS 68	MECHANISMLPS 68
HG 32	HYDRAULIC SYSTEMS AND GUIDES	EXIDIA 32	API CIS-32 EP		TRUSLIDE OGF	TIARO BK 32	WAY SI 32 WAYCUT N 32	ENGINE K 32	ENERGOL GHL 32	VAITAK OGF	MAGNA GC 32	VISTAC OIL 32X
HG 68		EXIDIA 68	API CIS-68 EP	ARAL DEGANIT B 68	TRUSLIDE 68	TIARO BK 68	WAY SI 68 WAYCUT N 68	ENGINE HY 68	ENERGOL GHL 68	VAITAK 68	MAGNA AX 68	
G 32		GR MU EP 1	APIGREASE PGX-1	ARAL ARALUB HL 1	LITHOLINE HEPR.1	LITIO EP 1	GREASE LI EP 1	RULTEN 900 EP 1	GREASE LTX1 GREASE LTX1-EP	BRYGREASE LT 1 BRYGREASE LT1EP1	SPHEEROL APT 1 SPHEEROL EP 1	DURALITH GREASE EP 1
G 68	MULTI FUNCTIONING GREASES	GR MU EP 2	APIGREASE LT-S APIGREASE PGX-2	ARAL ARALUB HL 2	LITHOLINE HEPR.2	LITIO EP 2	GREASE LI EP 2	RULTEN 900 N2 EP 2	GREASE LTX2 GREASE LTX2-EP	BRYGREASE LT 2 BRYGREASE LT2EP2	SPHEEROL APT 2 SPHEEROL EP 2	DURALITH GREASE EP 2
G 220		GR MU EP 3	APIGREASE CR-S APIGREASE PGX-3	ARAL ARALUB LF 3	LITHOLINE HEPR.3	PILMIT 3	GREASE LI EP 3	RULTEN 900 N. 3	GREASE LTX3	BRYGREASE LT 3 BRYGREASE LT3EP3	SPHEEROL APT 3 SPHEEROL EP 3	DURALITH GREASE EP 3

ISO AND UNI SYMBOLS	APPLICATION FIELD												
AN 68	LUBRIFICAT. LOSS	LG AN 68	MOVIXA 68	NURAY 68	EPAL 68	ARIAN 68	RENOLIN 68	BEARING 68	IP ARILLA OIL 68	CRUCOLAN 68	BETA 52/68	INDUSTRIAL 68	
CB 32	GEARS MODERATELY CHARGED	OLEOL HH CB 32	POLYTELIS 32	TERESSO 32 NUTO 32	BRIGHT 32	SOLNA 32	RENOLIN 32	FILETE V 32 PRIESTAN 32	IP HERMEA OIL 32 IP HYDRUS OIL 32	CRUCOLAN 32	BETA 30/32	OLNEO 32	
CB 68		OLEOL HH CB 68	POLYTELIS 68	TERESSO 68 NUTO 68	BRIGHT 68	SOLNA 68	RENOLIN 68	FILETE V 68 PRIESTAN 68	IP HERMEA OIL 68 IP HYDRUS OIL 68	CRUCOLAN 68	BETA 52/68	OLNEO 68	
CB 150		OLEOL HH CB 150	POLYTELIS 150	NUTO 150	BRIGHT 150	SOLNA 150	SOLNA 150	RENOLIN 150	FILETE V 150 PRIESTAN 150	IP HERMEA OIL 150 IP HYDRUS OIL 150	CRUCOLAN 150	BETA 120/150	OLNEO 150
CC 150	GEARS VERY CHARGED	OLGEAR EP CC 150	REDUCTELF SP 150	SPARTAN EP 150	ELTON EP 150	GIRAN 150	RENEPCOMFOND 104	RILEN EP 150	IP MELLANA OIL 150	LAMORA 150	DELTA EP 118/150	DACTA EP 150	
CC 320		OLGEAR EP CC 320	REDUCTELF SP 320	SPARTAN EP 320	ELTON EP 320	GIRAN 320	RENEPCOMFOND 108 RENEP SUPER 6	RILEN EP 320	IP MELLANA OIL 320	LAMORA 320	DELTA EP 230/320	DACTA EP 320	
CC 460		OLGEAR EP CC 460	REDUCTELF SP 460	SPARTAN FP 460	ELTON EP 460	GIRAN 460	GIRAN 460	RENEPCOMFOND 110 RENEP SUPER 10	RILEN EP 460	IP MELLANA OIL 460	LAMORA 460	DELTA EP 320/460	DACTA EP 460
FD 5	SPINDLES BEARINGS AND COUPLED CLUTCHES	OLEOL HM FD 5	SPINELF 5	NUTO H 5	NEDEL 5	HYDRAN 10	RENOLIN MR 1	FILETE V 5	IP HYDRUS OIL 05	CRUCOLAN 5	VELOX 13/05	OLEODIN 5 OLNEO HLP 5	
FD 10		OLEOL HM FD 10	SPINELF 10	SPINESSO 10	NEDEL 10	HYDRAN 10	RENOLIN MR 3	FILETE V 10	IP HYDRUS OIL 10	CRUCOLAN 10	VELOX 15/10	OLEODIN 10 OLNEO HLP 10	
FD 22		OLEOL HM FD 22	SPINELF 22	SPINESSO 22	NEDEL 22	HYDRAN 22	HYDRAN 22	RENOLIN MR 5	FILETE V 22	IP HYDRUS OIL 22	CRUCOLAN 22	VELOX 20/15	OLEODIN 22 OLNEO HLP 22
G 32	GUIDES	WAY LUBE EP G 32	MOGLIA 32	FEBIS K 32	ARIF T 32	HYDRAN G 32	RENOLIN 1	NOOROP V 32	IP BANTIA OIL HG 32	LAMORA SUPER POLADD 32	ALPHA 29/32	SLEDOL 32	
G 68		WAY LUBE EP G 68	MOGLIA 68	FEBIS K 68	ARIF T 68	HYDRAN G 68	RENEP 2	NOOROP V 68	IP BANTIA OIL HG 32	LAMORA SUPER POLADD 68	ALPHA 52/68	SLEDOL 68	
G 220		WAY LUBE EP G 220	MOGLIA 220	FEBIS K 220	ARIF T 220	HYDRAN G 220	RENEP 5	NOOROP V 220	IP BANTIA OIL G.220	LAMORA SUPER POLADD 220	ALPHA 150/220	SLEDOL 220	
HM 32	HYDROSTATIC SYSTEMS	OLEOL HM 32	ELFOLNA 32	NUTO H 32	HYDER 32	HYDRAN 32	RENOLIN B 32	FILETE V 32	IP HYDRUS OIL 32	LAMORA 32	HYDROLUBE 30/32	OLEODIN 32 OLNEO HLP 32	
HM 46		OLEOL HM 46	ELFOLNA 46	NUTO H 46	HYDER 46	HYDRAN 46	RENOLIN B 46	FILETE V 46	IP HYDRUS OIL 46	LAMORA 46	HYDROLUBE 40/46	OLEODIN 46 OLNEO HLP 46	
HM 68		OLEOL HM 68	ELFOLNA 68	NUTO H 68	HYDER 68	HYDER 68	HYDRAN 68	RENOLIN B 68	FILETE V 68	IP HYDRUS OIL 68	LAMORA 68	HYDROLUBE 52/68	OLEODIN 68 OLNEO HLP 68
HG 32	HYDRAULIC SYSTEMS AND GUIDES	OLEOL HG 32	HYGLISS 32	FEBIS K 32	TERCAL 32	HYDRAN G 32	RENOLIN 1	FILETE VE 32	IP BANTIA OIL HG 32	LAMORA 32	HYDROLUBE EP 30/32	SLEDOL GC 32	
HG 68		OLEOL HG 68	HYGLISS 68	FEBIS K 68	TERCAL 68	HYDRAN G 68	HYDRAN G 68	RENOLIN 3	FILETE VE 68	IP BANTIA OIL HG 68	LAMORA 68	HYDROLUBE EP 52/68	SLEDOL GC 68
G 32	MULTI FUNCTIONING GREASES	LHTGREASE XM 1	ROLEXA 1 EPEXA 1	BEACON EP 1	LITNER EP 1	MARSON EPL 1	RENOLIT 1	VEGA 1	IP ATHESIA GR 1 IP ATHESIA GREP 1	CENTOPLEX 1 EP	LITGREASE EP 1	ROLLER EP 1	
G 68		LHTGREASE XM 2	ROLEXA 2 EPEXA 2	BEACON 2 ESSO GP GREASE	LITNER EP 2	MARSON EPL 2	MARSON EPL 2	RENOLIT 2 RENOLIT FEP 2	VEGA 2	IP ATHESIA GR 2 IP ATHESIA GREP 2	CENTOPLEX 2 EP	LITGREASE EP 2	ROLLER EP 2
G 220		LHTGREASE XM 3	ROLEXA 3	BEACON 3	LITNER EP 3	MARSON EPL 3	MARSON EPL 3	RENOLIT 3 RENOLIT FEP 3	VEGA 3	IP ATHESIA GR 3	CENTOPLEX 3 EP	LITGREASE EP 3	ROLLER EP 3



ISO AND UNI SYMBOLS	APPLICATION FIELD	Shell	ROLOIL	REINACH	Q8	REPOL CAVTEX	Persian Oil	Alcotecnica	Mobil	Shell	Shell	Shell	Shell
AN 68	LUBRIFCATION LOSS	TECNOL 68	MILPAR 68	MILPAR 68	VERDI 68	CASTOR 68	TECNOL 68	MILPAR 68	RUBREX 400	MACHINERY 68	MACHINERY 68	MACHINERY 68	MACHINERY 68
CB 32	GEARS	VITROL 32	TURBO 32	VERDI 32	REGULUS 32 LAMBUSH HY 32	REGULUS 32 LAMBUSH HY 32	VITROL 32	TURBO 32	MOBIL VACTRA OIL LIGHT	TELEDINAX 32	TELEDINAX 32	TELEDINAX 32	TELEDINAX 32
CB 68	MODERATELY CHARGED	VITROL 68	TURBO 68	VERDI 68	REGULUS 68 LAMBUSH HY 68	REGULUS 68 LAMBUSH HY 68	VITROL 68	TURBO 68	MOBIL VACTRA OIL MEDIUM	TELEDINAX 68	TELEDINAX 68	TELEDINAX 68	TELEDINAX 68
CB 150	GEARS	VITROL 150	TURBO 150	VERDI 150	REGULUS 150	REGULUS 150	VITROL 150	TURBO 150	MOBIL VACTRA OIL EXTRA HEAVY	TELEDINAX 150	TELEDINAX 150	TELEDINAX 150	TELEDINAX 150
CC 150	GEARS VERY CHARGED	REDOL EP 150	ROTO EP 150	GOYA 150	TAURUS WRP 150	TAURUS WRP 150	REDOL EP 150	ROTO EP 150	MOBIL GEAR 629	GEAR OIL EP 150	GEAR OIL EP 150	GEAR OIL EP 150	GEAR OIL EP 150
CC 320	GEARS VERY CHARGED	REDOL EP 320	ROTO EP 320	GOYA 320	TAURUS WRP 320	TAURUS WRP 320	REDOL EP 320	ROTO EP 320	MOBIL GEAR 632	GEAR OIL EP 320	GEAR OIL EP 320	GEAR OIL EP 320	GEAR OIL EP 320
CC 460	GEARS VERY CHARGED	REDOL EP 460	ROTO EP 460	GOYA 460	TAURUS WRP 460	TAURUS WRP 460	REDOL EP 460	ROTO EP 460	MOBIL GEAR 634	GEAR OIL EP 460	GEAR OIL EP 460	GEAR OIL EP 460	GEAR OIL EP 460
FD 5	SPINDLES, BEARINGS AND COUPLED CLUTCHES	IDROL 10	VELOX 5	ORION 5	ORION 5	ORION 5	IDROL 10	VELOX 5	MOBIL VELOCITE OIL No. 4	TELEDINAX 5	TELEDINAX 5	TELEDINAX 5	TELEDINAX 5
FD 10	SPINDLES, BEARINGS AND COUPLED CLUTCHES	IDROL 10	VELOX 10	ORION 10	ORION 10	ORION 10	IDROL 10	VELOX 10	MOBIL VELOCITE OIL DTE 21	TELEDINAX 10	TELEDINAX 10	TELEDINAX 10	TELEDINAX 10
FD 22	SPINDLES, BEARINGS AND COUPLED CLUTCHES	IDROL 22	VELOX 22	SIRIUS H 22	SIRIUS H 22	SIRIUS H 22	IDROL 22	VELOX 22	MOBIL VELOCITE OIL DTE 22	TELEDINAX 22	TELEDINAX 22	TELEDINAX 22	TELEDINAX 22
G 32	GUIDES	AROL S 32	LUBEX K 32	GEMINI CS 32	GEMINI CS 32	GEMINI CS 32	AROL S 32	LUBEX K 32	MOBIL VOLUME 105	OLG 32	OLG 32	OLG 32	OLG 32
G 68	GUIDES	AROL S 68	LUBEX K 68	GEMINI SW 68	GEMINI SW 68	GEMINI SW 68	AROL S 68	LUBEX K 68	MOBIL VACTRA OIL No. 2	OLG 68	OLG 68	OLG 68	OLG 68
G 220	GUIDES	AROL S 220	LUBEX K 220	GEMINI SW 220	GEMINI SW 220	GEMINI SW 220	AROL S 220	LUBEX K 220	MOBIL VACTRA OIL No. 4	OLG 220	OLG 220	OLG 220	OLG 220
HM 32	HYDROSTATIC SYSTEMS	IDROL 32	MOVO H 32	SIRIUS H 32	SIRIUS H 32	SIRIUS H 32	IDROL 32	MOVO H 32	MOBIL DTE 24	TELEDINAX 32	TELEDINAX 32	TELEDINAX 32	TELEDINAX 32
HM 46	HYDROSTATIC SYSTEMS	IDROL 46	MOVO H 46	SIRIUS H 46	SIRIUS H 46	SIRIUS H 46	IDROL 46	MOVO H 46	MOBIL DTE 25	TELEDINAX 46	TELEDINAX 46	TELEDINAX 46	TELEDINAX 46
HM 68	HYDROSTATIC SYSTEMS	IDROL 68	MOVO H 68	SIRIUS H 68	SIRIUS H 68	SIRIUS H 68	IDROL 68	MOVO H 68	MOBIL DTE 26	TELEDINAX HVI 46	TELEDINAX HVI 46	TELEDINAX HVI 46	TELEDINAX HVI 46
HG 32	HYDRAULIC SYSTEMS AND GUIDES	AROL S 32	LUBEX K 32	GEMINI CS 32	GEMINI CS 32	GEMINI CS 32	AROL S 32	LUBEX K 32	MOBIL VAQUOLINE OIL 1405	TELEDINAX EP 32	TELEDINAX EP 32	TELEDINAX EP 32	TELEDINAX EP 32
HG 68	HYDRAULIC SYSTEMS AND GUIDES	AROL S 68	LUBEX K 68	GEMINI CS 68	GEMINI CS 68	GEMINI CS 68	AROL S 68	LUBEX K 68	MOBIL VAQUOLINE OIL 1409	TELEDINAX EP 68	TELEDINAX EP 68	TELEDINAX EP 68	TELEDINAX EP 68
G 32	MULTI FUNCTIONING GREASES	LT GREASE 1	LITE EP 1	LIBRA GREASE 1	LIBRA GREASE 1	LIBRA GREASE 1	LT GREASE 1	LITE EP 1	MOBILPLEX 46	UNIVERSAL GREASE 1	UNIVERSAL GREASE 1	UNIVERSAL GREASE 1	UNIVERSAL GREASE 1
G 68	MULTI FUNCTIONING GREASES	LT GREASE 2	LITE EP 2	LIBRA GREASE 2	LIBRA GREASE 2	LIBRA GREASE 2	LT GREASE 2	LITE EP 2	MOBILPLEX 47	UNIVERSAL GREASE 2	UNIVERSAL GREASE 2	UNIVERSAL GREASE 2	UNIVERSAL GREASE 2
G 220	MULTI FUNCTIONING GREASES	LT GREASE 3	LITE EP 3	LIBRA GREASE 3	LIBRA GREASE 3	LIBRA GREASE 3	LT GREASE 3	LITE EP 3	MOBILPLEX 48	UNIVERSAL GREASE 3	UNIVERSAL GREASE 3	UNIVERSAL GREASE 3	UNIVERSAL GREASE 3

ISO AND UNI SYMBOLS	APPLICATION FIELD	SYNBRGD	TAMOIL	TEMNEX	★	TOTAL	Vabtril	VALVOLINE	Vanguard	VSCO	WEBER	WZADOIL
AN 68	LUBRICATION LOSS	HYDRAULIC N 68	TAMLUBE OIL 68	VERTEX 68	OMNIS 68 ALCALD OIL 60	CORTIS 68	METIX 68	CIR 68	KOMOL ST 68	SIGNAL TR 68 (5)	WEBER WESCOM 68	ENGINE 68
CB 32	GEARS MODERATELY CHARGED	PACEMAKER R003	INDUSTRIAL OIL 32	CONTEX 32	OMNIS 32 RANDO OIL HD 32	CORTIS 32 AZOLLA ZS 32	METRA 32	CIR 32	KOMOL ST 32	SIGNAL M.U.EP 32 (3)	WEBER WA 32	ENGINE RE 32
CB 68		PACEMAKER R005	INDUSTRIAL OIL 68	CONTEX 68	OMNIS 68 RANDO OIL HD 68	CORTIS 68 AZOLLA ZS 68	METRA 68	CIR 68	KOMOL ST 68	SIGNAL M.U.EP 68 (5)	WEBER WA 68	ENGINE RE 68
CB 150		PACEMAKER R0012	INDUSTRIAL OIL 150	CONTEX 150	OMNIS 150 RANDO OIL HD 150	CORTIS 150 AZOLLA ZS 150	METRA 150	CIR 150	KOMOL ST 150	SIGNAL M.U.EP 150 (10)	WEBER WA 150	ENGINE RE 150
CC 150	GEARS VERY CHARGED	PACEMAKER R0012	CHITEREP LUBR 150	FACTOR 150	MEROPA 150	CARTER EP 150	GEARLUBE EP 150	GEAR EP 150	GEARING EP 150	SIGNAL M.U.EP 150 (10)	WEBER FARGO EP 150	ENGINE E P 150
CC 320		PACEMAKER R0024	CHITEREP LUBR 320	FACTOR 320	MEROPA 320	CARTER EP 320	GEARLUBE EP 320	GEAR EP 320	GEARING EP 320	SIGNAL M.U.EP 320 (22)	WEBER FARGO EP 320	ENGINE E P 320
CC 460		PACEMAKER R0032	CHITEREP LUBR 460	FACTOR 460	FACTOR 460	MEROPA 460	CARTER EP 460	GEARLUBE EP 460	GEAR EP 460	GEARING EP 460	SIGNAL M.U.EP 460 (37)	WEBER FARGO EP 460
FD 5	SPINDLES, BEARINGS AND COUPLED CLUTCHES			ECTON 5	300 OIL 5		RINOL 5	ETC 5	KOMOL SVR 5	SIGNAL ELUROS 5 (12)	WEBER W.L. 10	ENGINE HY SY 05B
FD 10			TAMSPINDLE OIL 10	ECTON 10	SPRINTEX OIL 10	AZOLLA ZS 15	RINOL 10	ETC 10	KOMOL SVR 10	SIGNAL CO 10 (1)	WEBER W.L. 15	ENGINE HY SY 10B
FD 22			TAMSPINDLE OIL 22	ECTON 22	ECTON 22	SPRINTEX OIL 22	AZOLLA ZS 15	RINOL 22	ETC 22	SIGNAL CO 22 (2)	WEBER W.L. 22	ENGINE HY SY 22B
G 32	GUIDES	PACEMAKER R003	TAMWAY OIL 32	BARTON 11		DROSERA MS 32	METRA K 32	GES 32	C.O. SPECIAL 32	SIGNAL VUJU 32 (3)	WEBER WAY 32	ENGINE HD T 02
G 68		PACEMAKER 55	TAMWAY OIL 68	BARTON 20	WAY LUBRICANT 68	DROSERA MS 68	METRA K 68	GES 68	STOL 68	SIGNAL M.V.SG 68 (5)	WEBER WAY 68	ENGINE HD T 08
G 220		PACEMAKER 80	TAMWAY OIL 220	BARTON 44	WAY LUBRICANT 220	DROSERA MS 220	METRA K 220	GES 220	STOL 220	SIGNAL M.V.SG 220 (12)	WEBER WAY 220	ENGINE HD T 20
HM 32	HYDROSTATIC SYSTEMS	PACEMAKER 32	HYDRAULIC OIL 32	ECTON X 32	RANDO OIL HD 32	AZOLLA ZS 32	GAMMA X 32	HYDRAULIC H.P 32	HYDRAULIC 32	SIGNAL CO 32 (3)	WEBER WL 32	ENGINE HY SY 32B
HM 46		PACEMAKER 46	HYDRAULIC OIL 46	ECTON X 46	RANDO OIL HD 46	AZOLLA ZS 46	GAMMA X 46	HYDRAULIC H.P 46	HYDRAULIC 46	SIGNAL CO 46 (4)	WEBER WL 46	ENGINE HY SY 46B
HM 68		PACEMAKER 68	HYDRAULIC OIL 68	ECTON X 68	RANDO OIL HD 68	AZOLLA ZS 68	GAMMA X 68	HYDRAULIC H.P 68	HYDRAULIC 68	SIGNAL CO 68 (5)	WEBER WL 68	ENGINE HY SY 68B
HG 32	HYDRAULIC SYSTEMS AND GUIDES	PACEMAKER R003	TAMWAY OIL 32	BARTON 11	CLEARTEX D RANDO OIL HD 32	DROSERA MS 32	METRA X 32	GES 32	C.O. SPECIAL 32	SIGNAL VUJU 32 (3)	WEBER WESSTOCK 32	ENGINE HOT 32/A
HG 68		PACEMAKER 55	TAMWAY OIL 68	BARTON 18	CLEARTEX F RANDO OIL HD 68	DROSERA MS 68	METRA X 68	GES 68	C.O. SPECIAL 68	SIGNAL VUJU 68 (5)	WEBER WESSTOCK 68	ENGINE HOT 68/A
G 32	MULTI-FUNCTIONING GREASES	SINT GREASE EP 1	TAMUTHGREASE 1P	GRASSO C-1 SPECK GRASSO MR 100	MULTIFAK EP 1 MAIRFAK 1	MULTIS EP 1 MULTIS 1	CSMPA 1 GREASE CSEEP 1 GREASE	L 1 EP GREASE	LIKO 1 LIKO EP 1	SIGNAL ROLSPER EP 1	WEBER GREASE MP 1	GOLD 200 F1 GOLD 200 EP 1
G 68		SINT GREASE EP 2	TAMUTHGREASE 2	GRASSO C-2 SPECK GRASSO MR 100	MULTIFAK EP 2 MULTIFAK HP 2	MULTIS EP 2 MULTIS 2	CSMPA 2 GREASE CSEEP 2 GREASE	L 2 EP GREASE	LIKO 2 LIKO EP 2	SIGNAL ROLSPER EP 2	WEBER GREASE MP 2	GOLD 200 F2 GOLD 200 EP 2
G 220		SINT GREASE EP 3	TAMUTHGREASE 3	GRASSO C-3 SPECK GRASSO MR 100	MULTIFAK HD 3 MAIRFAK HD 3	MULTIS EP 3 MULTIS 3	CSMPA 3 GREASE CSEEP 3 GREASE	L 3 EP GREASE	LIKO 3 LIKO EP 3	SIGNAL ROLSPER EP 3	WEBER GREASE MP 3	GOLD 200 F3 GOLD 200 EP 3

## Maintenance

### Lubrication

Refer to images following these written instructions:

Below are the directions that explain how and where to add oil to the different systems:

**CAUTION** Do not overfill any of the lubrication points, serious electrical damage may result.

### Outer Spindle

The Outer Spindle is hard chromed and is supported in tapered, cast iron spindle bushings. The Outer Spindle supports the Inner Spindle, bearings, seals etc... and maintains the boring rigidity.

#### Every 8 hours:

The Outer Spindle needs to be moved down to the lower limit, wiped clean, and then lightly coated with a **ISO VG 68 Way Oil**. This is very important, if the spindle is allowed to operate dirty the cast iron dust will act as an abrasive on the spindle chrome. This will cause the spindle to wear prematurely. The outer spindle is a very expensive item to replace.

#### Every 1000 Hours:

Open the sheet metal cover from the front of the spindle unit. There is a large nut where the outer spindle passes through the top of the spindle base. Using a spanner wrench or punch carefully remove the upper nut.

**Note:** *Do not adjust the nut below the felt wiper (see the mechanical section for correct adjustment of this nut).*

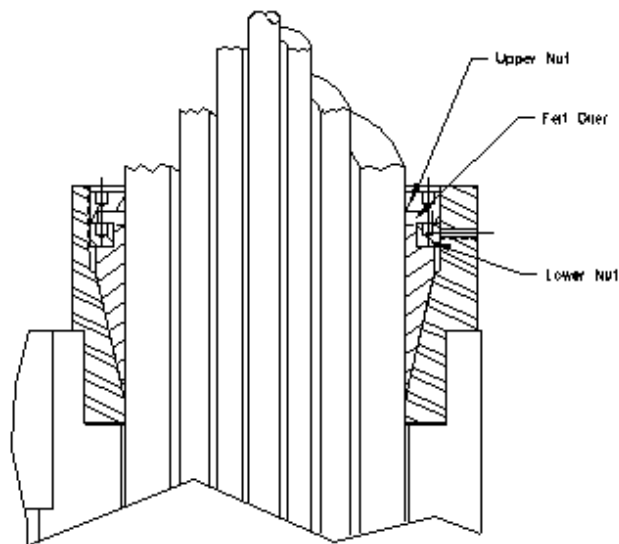

Slide the felt wiper back into place and tighten the Upper Nut back down.

### Upper Belt Housing

No lubrication is necessary in the Upper Belt Housing.



## Oil Reservoir System

Every 8 hours check the oil supply lines to the upper spindle to be sure they are full of oil.

### **IMPORTANT**

The oil reservoir system is located inside the lower portion of the column. This system lubricates the following:

- Ways
- Inner Spindle Bearings (Upper and Lower)
- Horizontal Ballscrew
- Outer Spindle

### **Every 175 Hours:**

The oil level of the reservoir should be checked, and filled with **ISO VG 68 WAY OIL**.

When the oil reservoir is low or empty on the F103/4/5A machine, the control will “LOW OIL” and will not run until the reservoir has been filled.

The oil system may require priming if the reservoir has been run empty. You can do this manually or automatically. To prime automatically, change the oiler machine parameter #123 to a value of 10. This will turn the oiler solenoid on every ten seconds as long as the spindle is running. Take note when the oil lines are full, reset the oiler parameter and operate the machine normally. To prime manually, open the air door on the lower left hand side of the column, locate the blue solenoid, press the manual override button on the solenoid repeatedly until the oil lines are full. You need to pause for a second between button presses to allow the valve to reset. Pressing the button too fast will not pump oil through the system.

## Inner Spindle Bearings

The Inner Spindle Bearings are lubricated from the oil reservoir system. It is normal for a small amount of this oil to seep through the spindle bearings and onto the cutterhead.

## Vertical Ballscrew Bearings

The Upper Pillow Block bearing is located on the top plate just below the driven sprocket. The lower bearing set is located at the bottom of the ballscrew in the spindle base.

### **Every 175 Hours:**

These bearings should be greased with **NLGI 2 White Lithium Grease**.

### Priming Spindle Base Oil Lines

1. After the spindle base has been placed on the column the oil lines must be purged of air.
2. Remove the oil lines located on the spindle base guide rails.

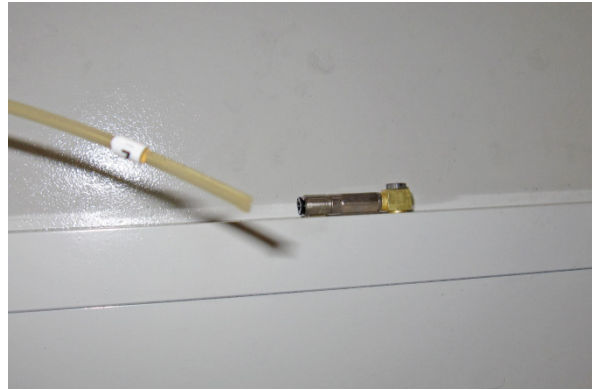

3. Open the door where the regulator is located.
4. Find the solenoid that has the #8 airline attached to it.
5. Manually activate the solenoid until oil flows out of the oil lines.

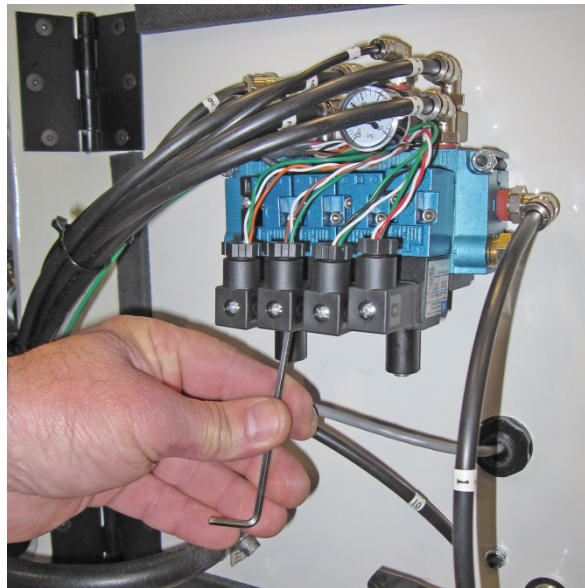

6. Reattach oil lines.

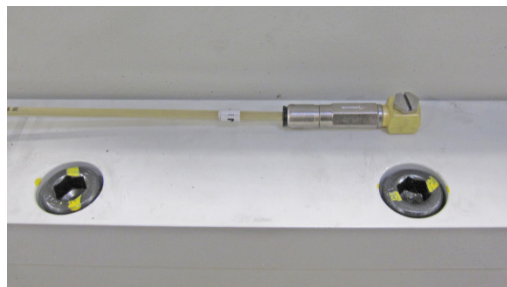

### Lubrication Locations

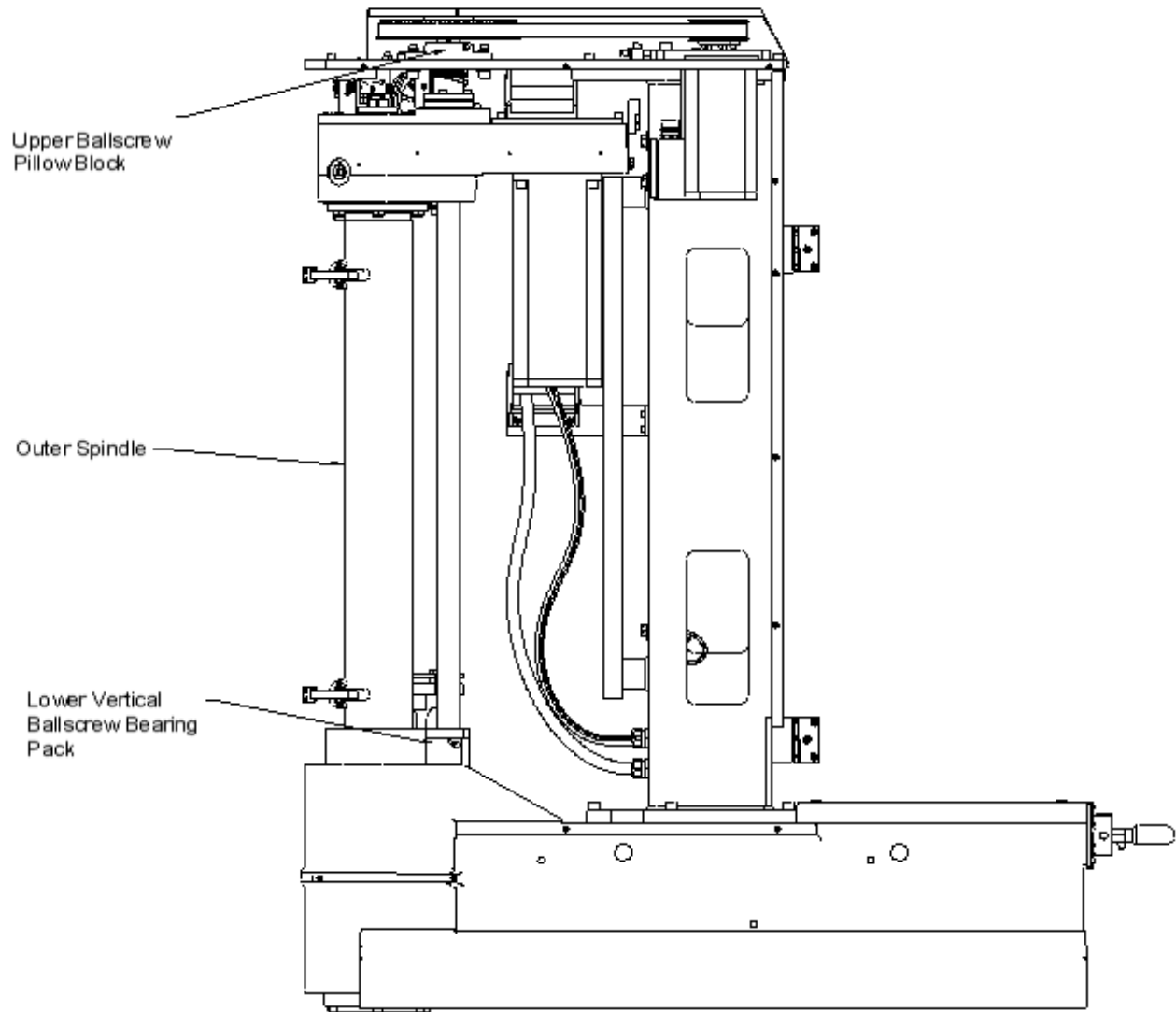

**Lubrication Locations cont:**

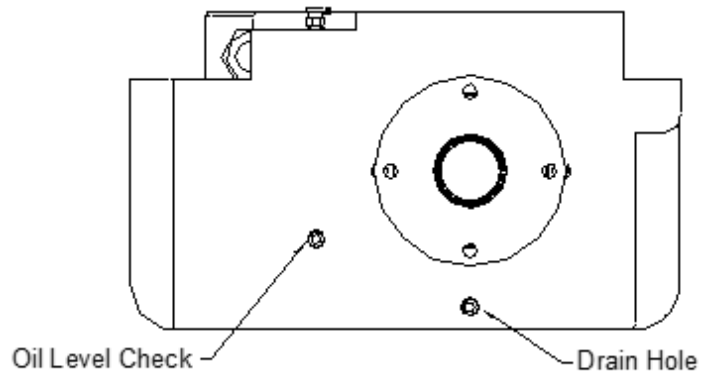
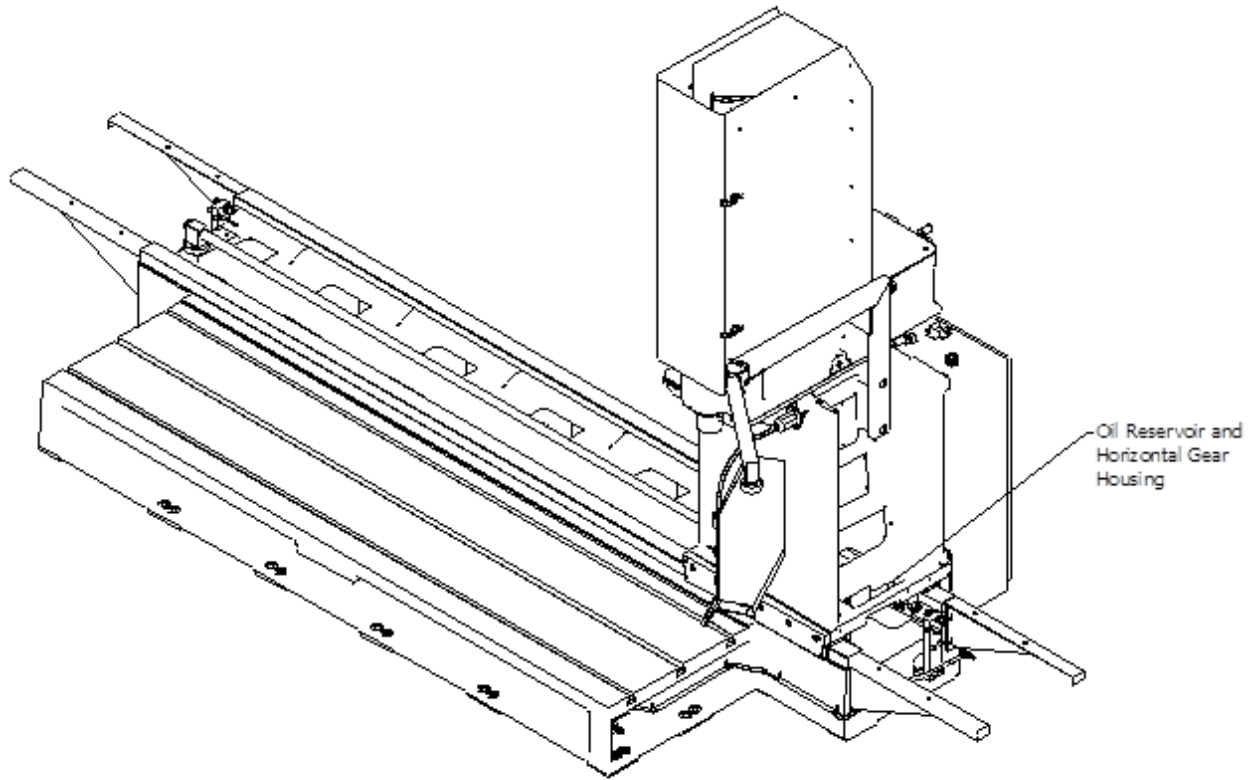

## Right Angle Drive Lubrication Information

All right angle drives require lubrication at the point where the pinion drive intersects with the drive gear. This is generally in the area where the cutterhead is attached, except for the units that have belt drive. There will be a small pipe plug that is removed to check oil level and add oil if needed. See illustration below for general locations.

With the drive mounted on the machine spindle the oil level should be even with the bottom of the pipe plug threads.

All Rottler Right Angle Drives are filled with Union 76 Turbine Oil 68 prior to shipment. Use this or an equivalent ISO VG68 oil if the need to add or change oil arises.

When adding oil, fill until oil starts to run out of fill hole. Allow excess oil to drain, then coat pipe plug threads with anti-seize compound and replace it.

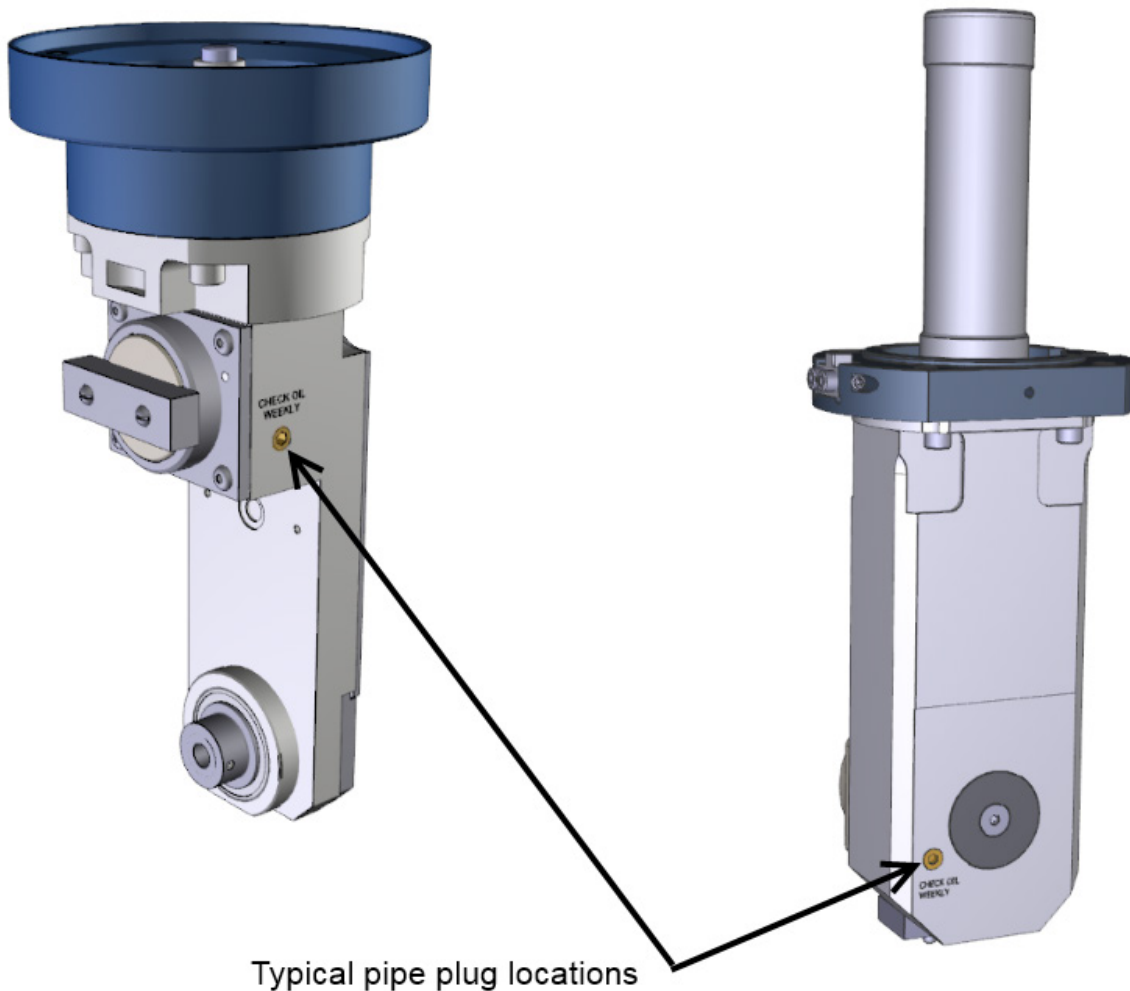

**Air Line Diagram**

**Image Currently Unavailable**

### F103/4/5M Wiring Diagram

A scalable version of this wiring diagram is located on manual CD.

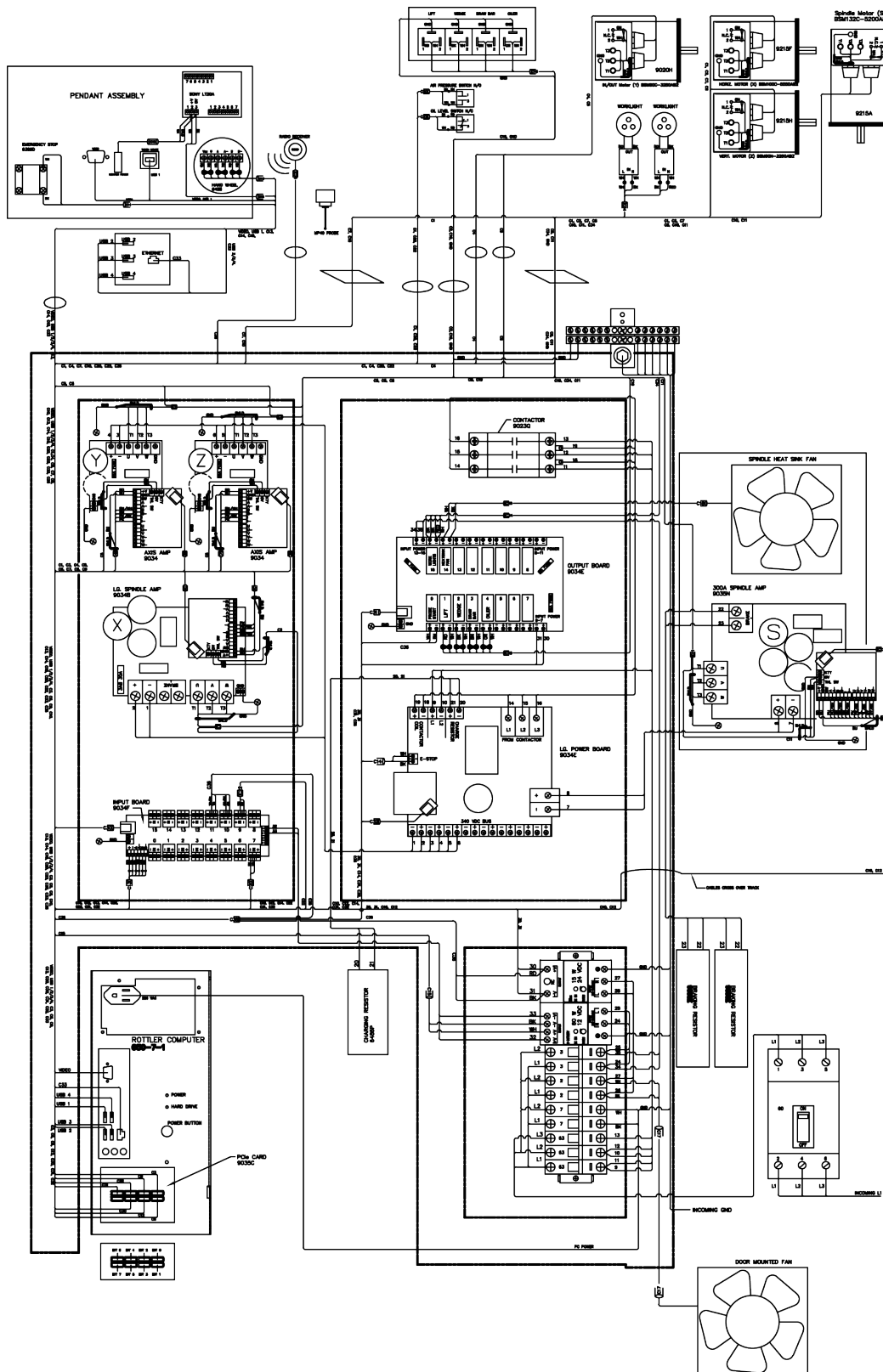

## 502-12-7B Sony LT20 Set Up Instructions

A standard initialization is carried out at the time of shipment, however it is possible to make the following selections depending on the intended use. Details of the settings at the time of shipment are given in each section.

### Changing between Inches and mm

Turn on the power while holding down the “RESET A” button and press the “MODE” key/ Press the Up arrow to change between inches/mm. Press the “SET” button to set and return to the measuring state. This device was set to mm st the time of shipment from Sony.  
To change the initial settings... Press and hold the “SET” key and “MODE” key for approximately 2 seconds.

Basic Operation:

“MODE” – To the next item.

“UP ARROW” – Select the item.

“SET” – Set Item.

**Note:** *Even if you select and item with the “UP ARROW” key, no changes will be made until you press the “SET” key.*

**Note:** *Once the initial setting modes had been entered it is not possible to return to the measuring state partway through. Press the “MODE” key repeatedly to skip items.*

### Basic Settings

Setting the display (2 channel Models).

One of the following may be chosen: A and B or Only A+B.

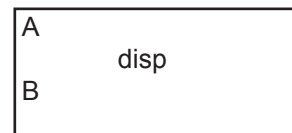

Setting the input signal resolution (channel A)

One of 0.0005, 0.001, 0.005 or 0.01 mm can be chosen.

Set the resolution to match the resolution of the connected measuring probe.

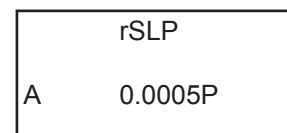



## Spindle Drive Belt Replacement / Adjustment

**CAUTION** Turn off power to machine before proceeding with this procedure.

The spindle drive belt is located in the upper spindle housing.

Remove the spindle door and covers.

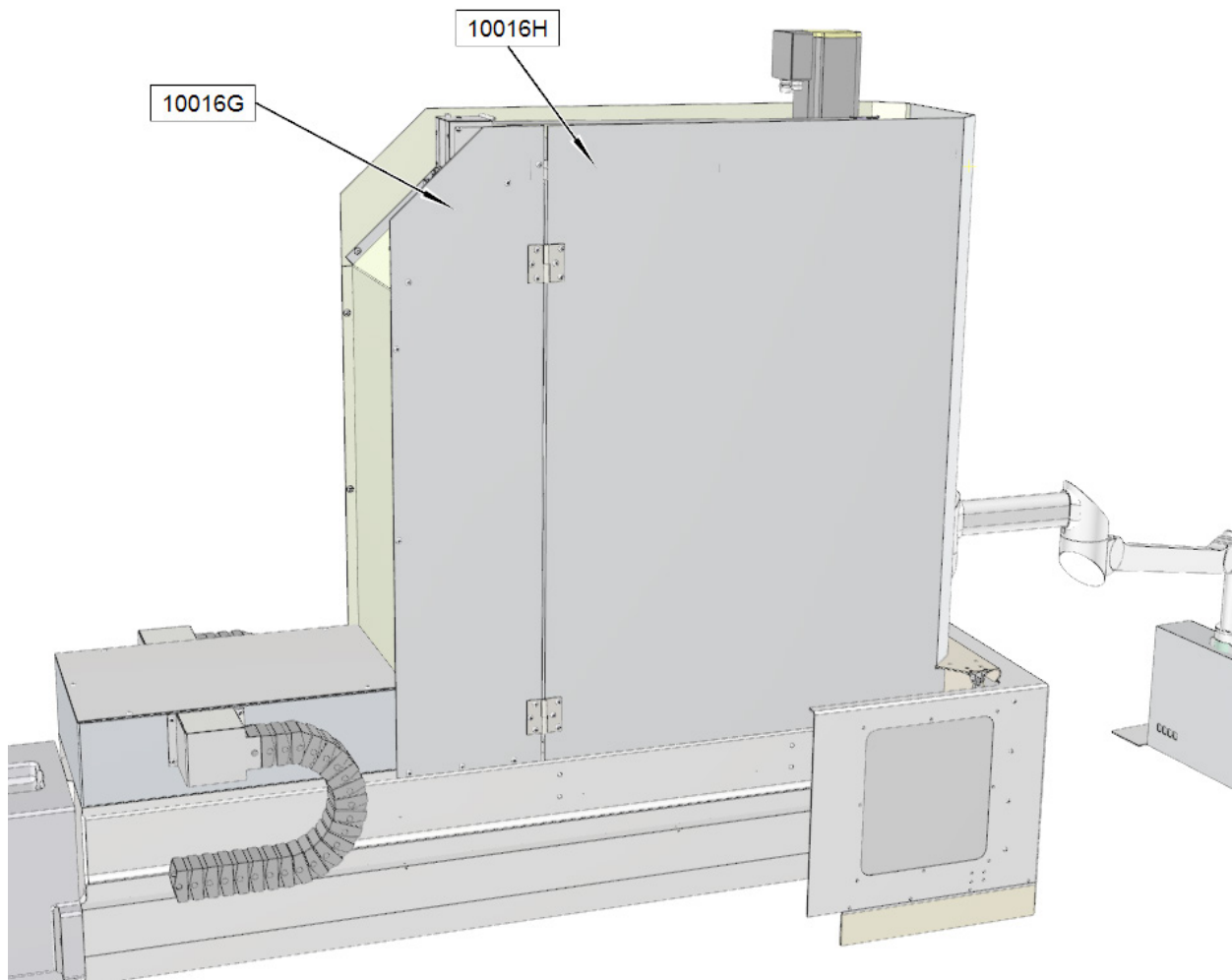

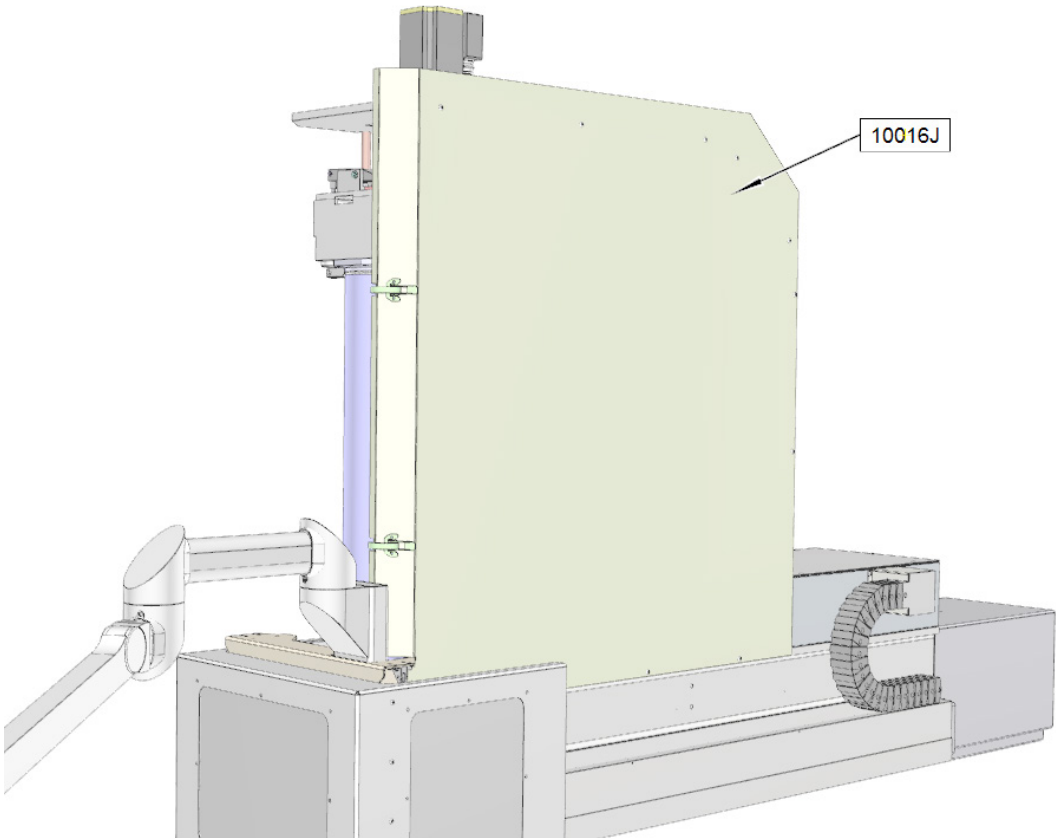

Lower spindle down onto a piece of wood to prevent the motor from falling.

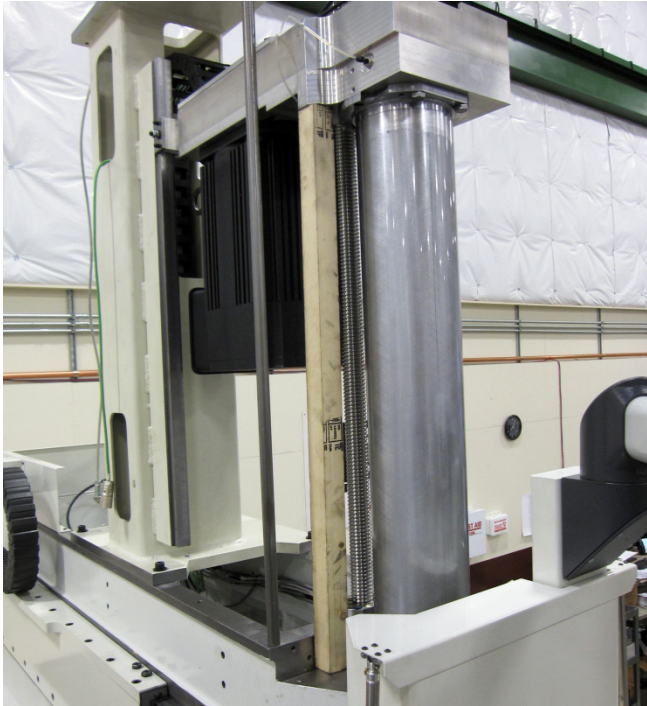

Remove the counter weight cable end from the upper housing.

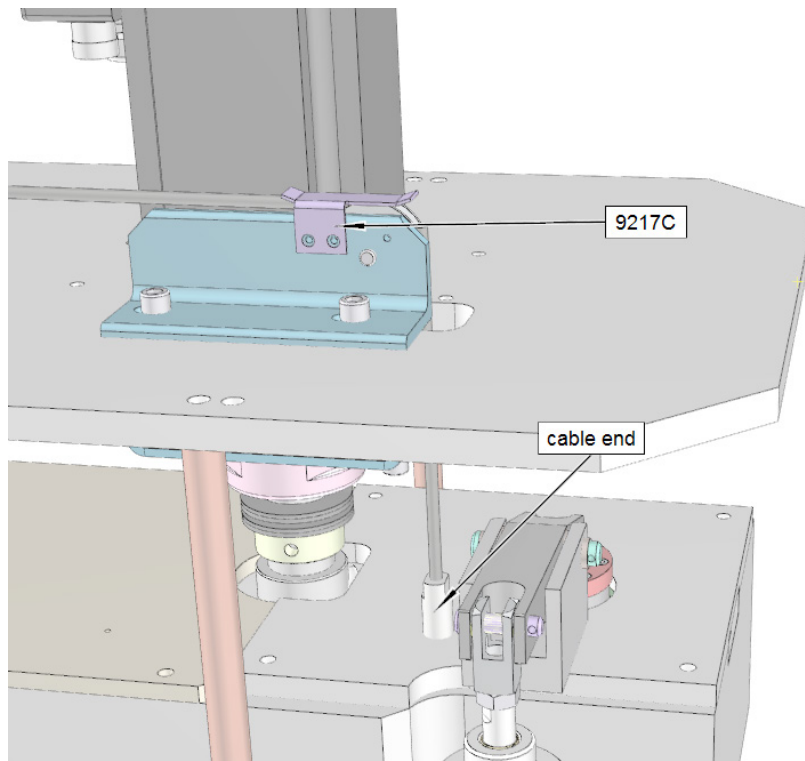

Remove Z-Axis motor, mount plate, and bracket.

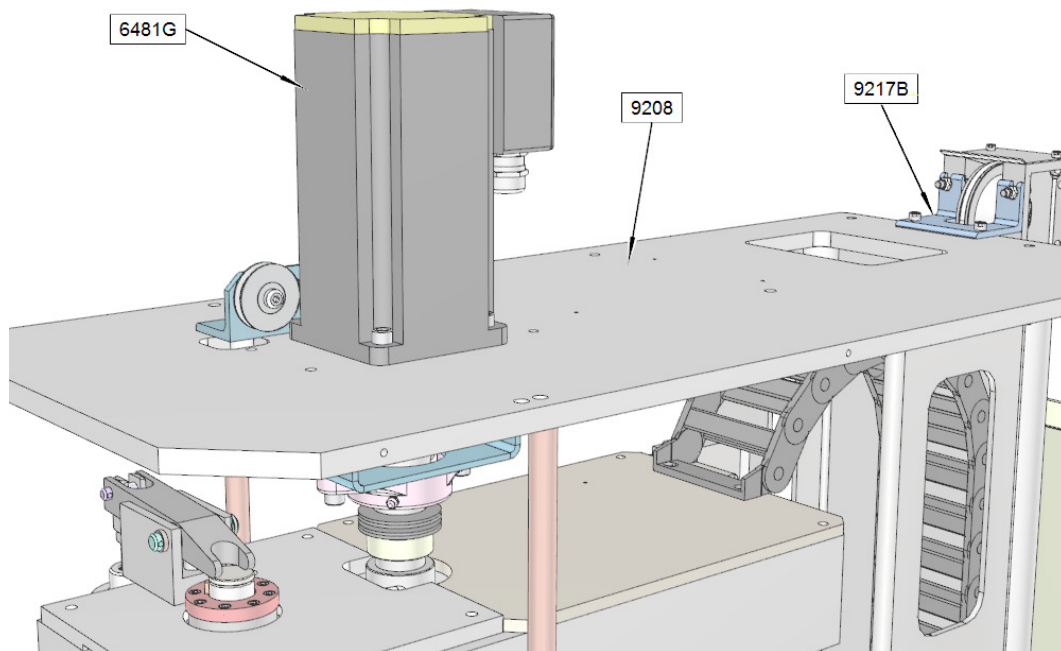

Remove drawbar bracket assembly and front housing cover plate.

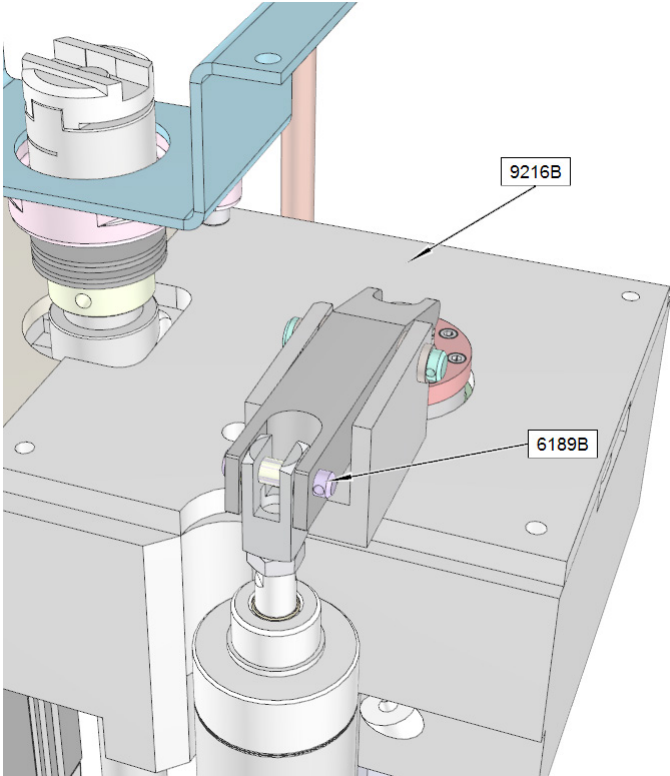

Remove rear housing cover plate.

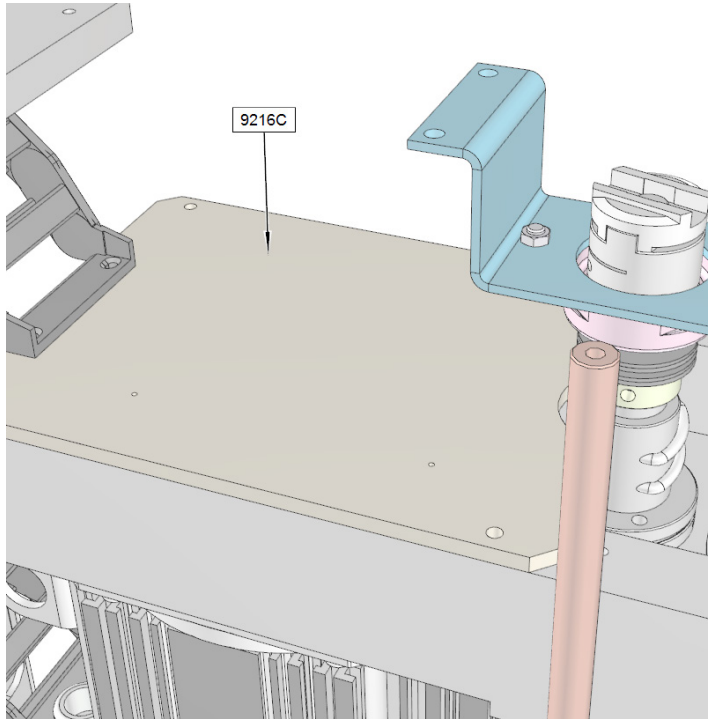

Loosen motor mount bolts and belt tension adjusting bolt.

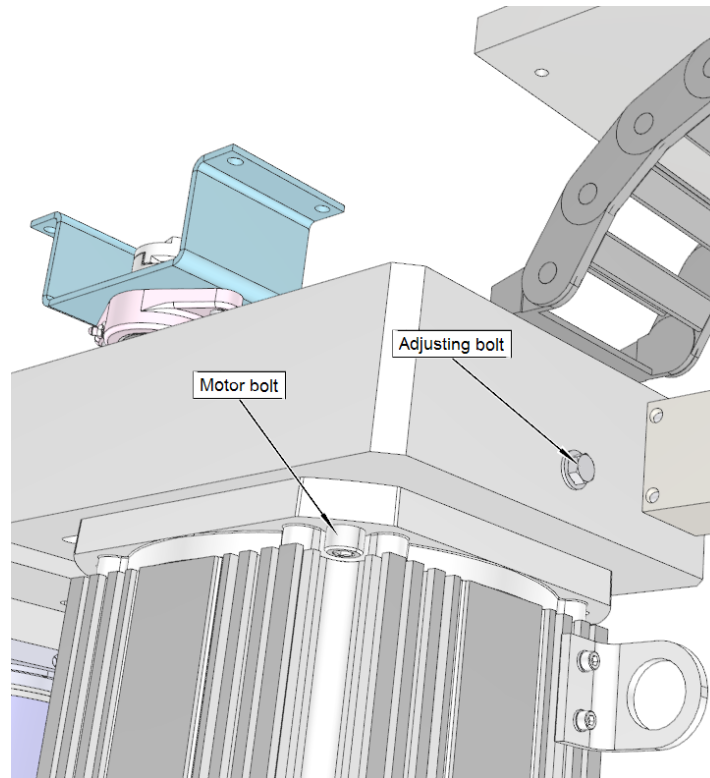

Remove and replace bolt.

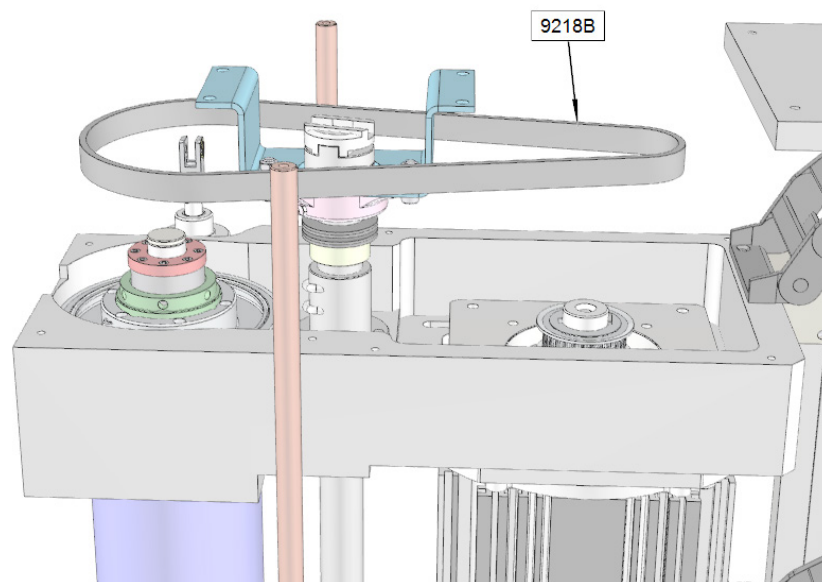

When the new belt is in place use the adjusting bolt to set the belt tension. Proper tension is when there is 5/16" of deflection when 2-4 lbs. of force is applied between the 2 pulleys.

## Outer Spindle Bushing Adjustment

The Lower Spindle Bushing will be adjusted in this demonstration.

1. Start the Rottler Software.
2. Move the spindle to its full downward position.



Retainer – O-Ring and felt are underneath

3. Loosen the four 10-24 bolts in the Retainer and pull out the O-Ring and Felt.
4. Loosen set screw at top of Bushing Carrier.
5. Take a punch and tighten Lower Bushing Nut with palm of hand. Raise spindle 5” and repeat. This helps set the bushing in the bushing carrier.

(WARNING: Do not tighten Spindle bushing retaining nut when spindle is at the top 3” of travel. Excessive wear and premature failure could result.)



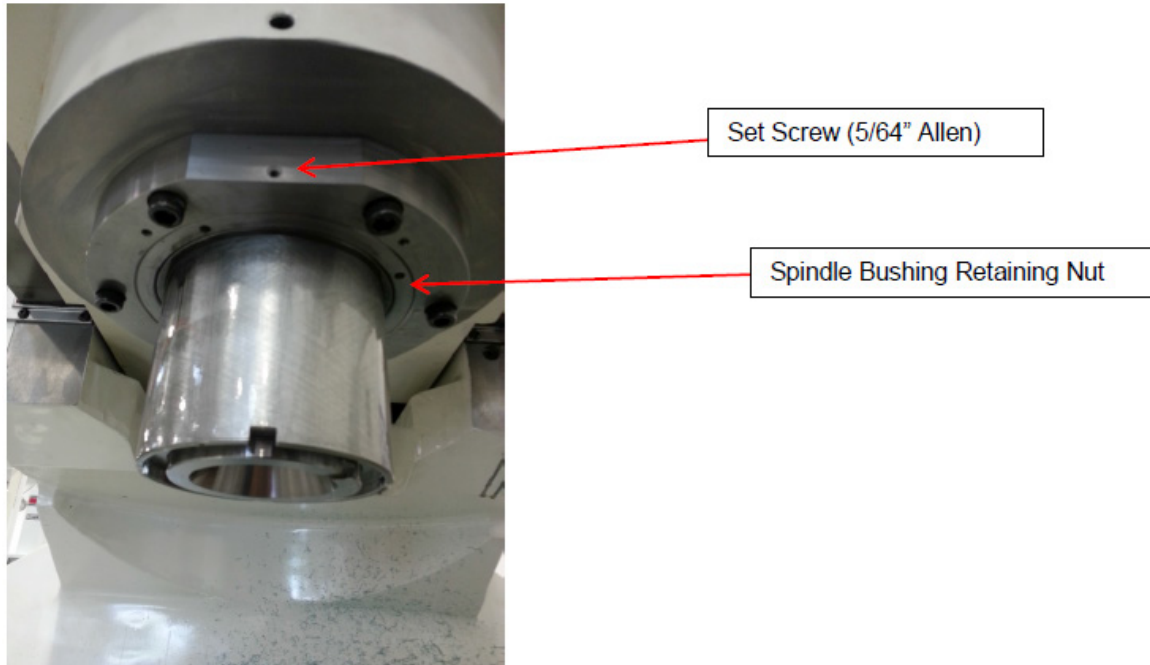

6. Once the Retaining Nut will not tighten any more, a couple soft taps with a punch and a hammer to tighten it is all that is necessary to finish procedure.
7. Re-Install Felt, O-Ring, then Retainer in that order. Tighten down (4) 10-24 bolts.
8. Tighten Set Screw in Bushing Carrier.

### Upper Bushing Adjustment

9. Be sure Spindle is at its home position (full upward position).
10. Repeat steps 3 and 4.
11. Take a punch and tighten Lower Bushing Nut with palm of hand. This time Lower spindle 5" and repeat.

(WARNING: Do not tighten Spindle bushing retaining nut when spindle is at the top 3" of travel. Excessive wear and premature failure could result.)

Once the Retaining Nut will not tighten any more, a couple soft taps with a punch and a hammer to tighten it is all that is necessary to finish procedure.  
Re-Install Felt, O-Ring, then Retainer in that order. Tighten down (4) 10-24 bolts.  
Tighten Set Screw in Bushing Carrier.

Note: It is recommended to sweep in your spindle after this maintenance procedure.

## Inner Spindle Adjustment

**WARNING**

FOLLOW ALL SAFETY PROCEDURES LISTED IN THE SAFETY SECTION OF THIS MANUAL BEFORE STARTING THIS PROCEDURE

Open the spindle base door.

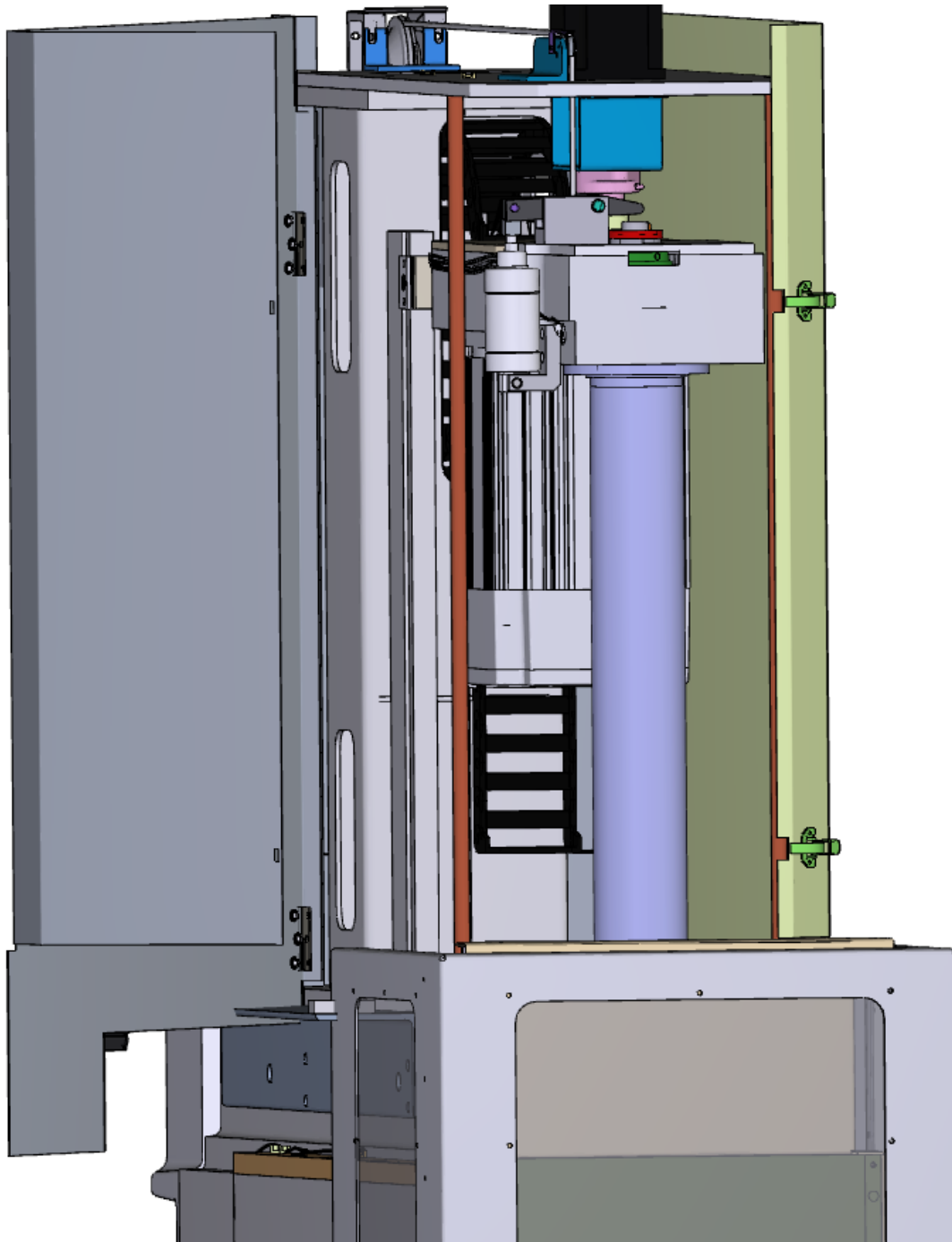

Install surfacing cutterhead or boring cutterhead with long tool holder onto spindle.



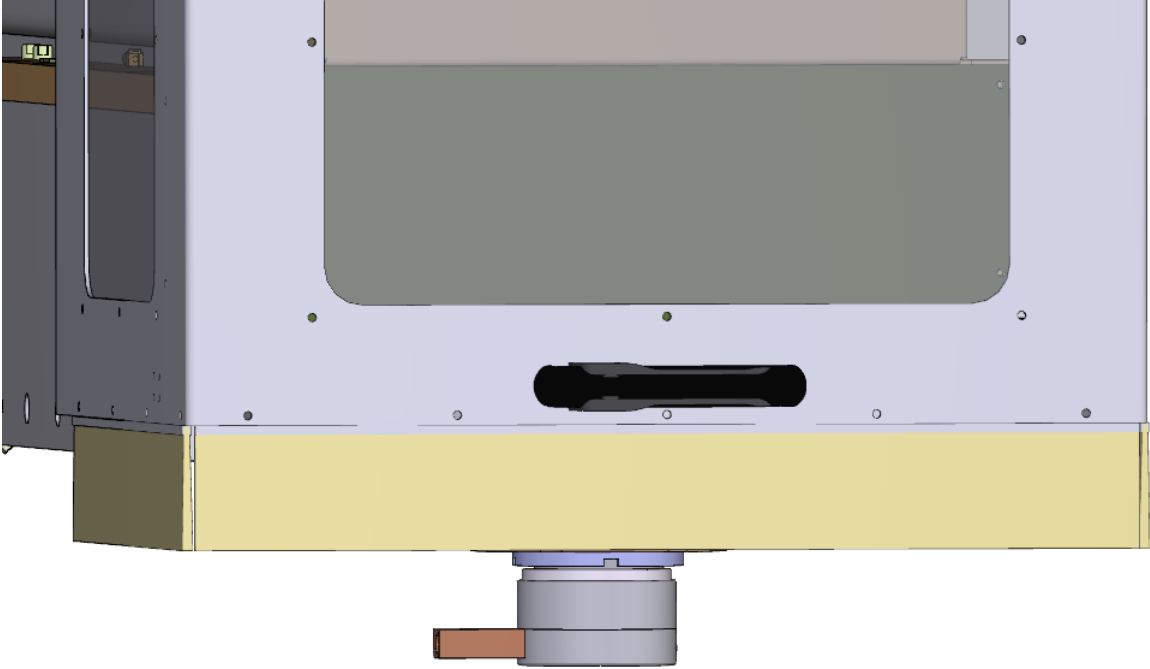

Locate opening in the belt housing.

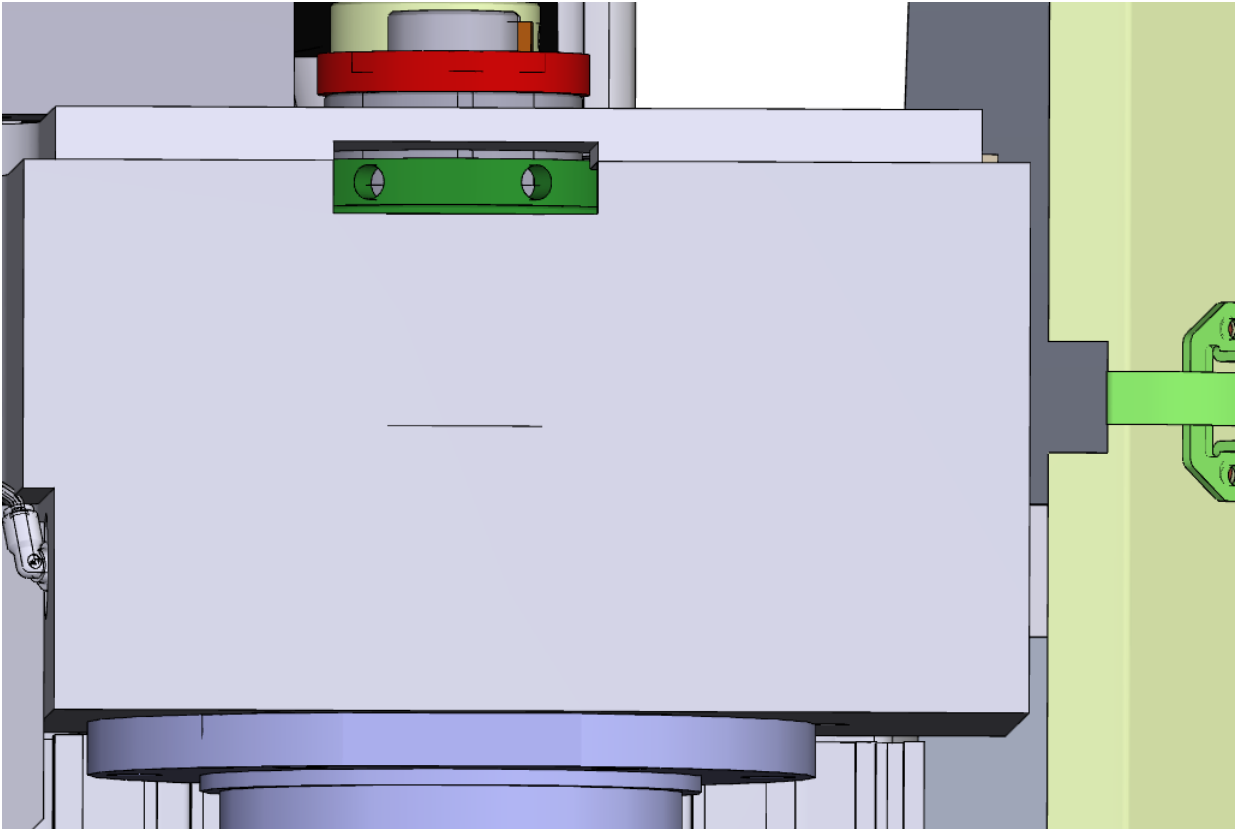

Insert a rod into one of the drilled holes of the adjustment nut. This is used to lock the adjustment nut in place so that the nut won't turn while inner spindle is turned.

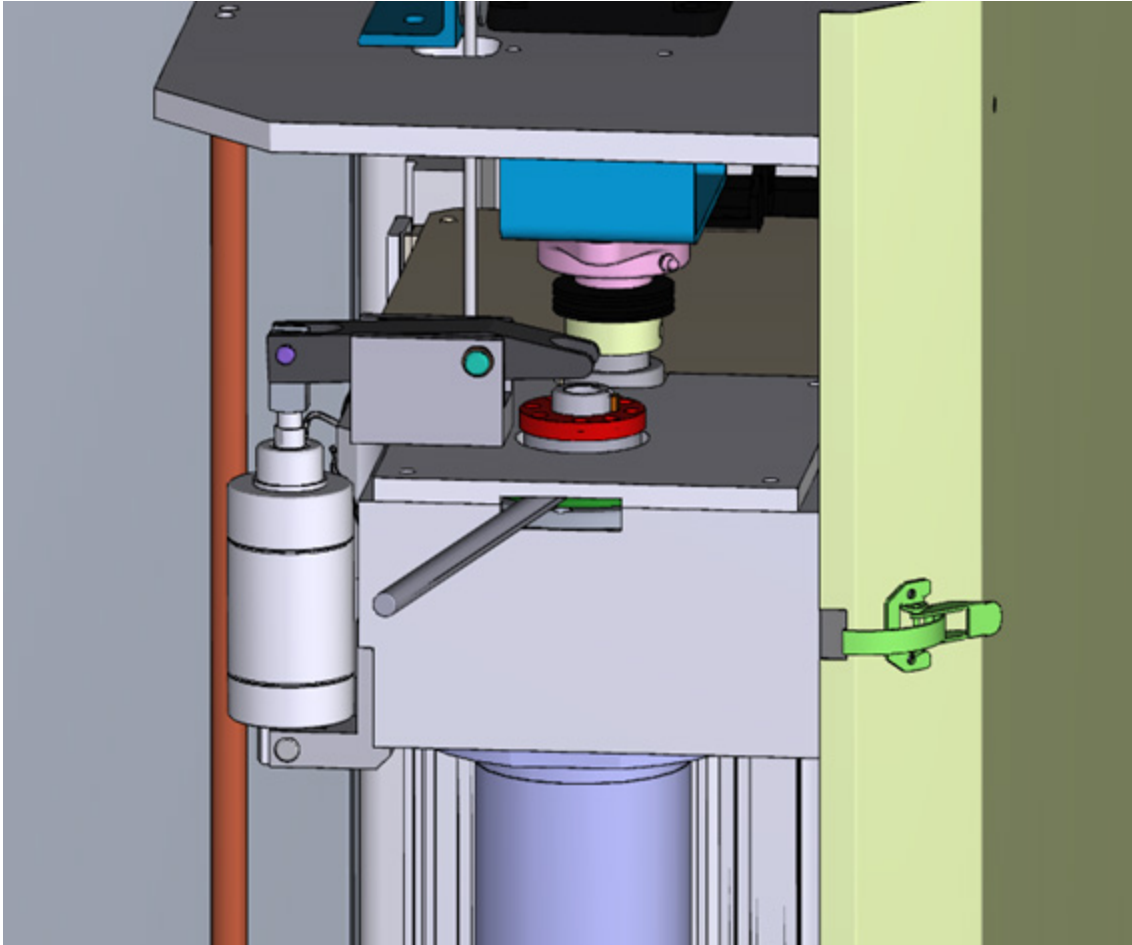

Grab hold of the cutterhead and turn it one turn clockwise to loosen the inner spindle adjustment.

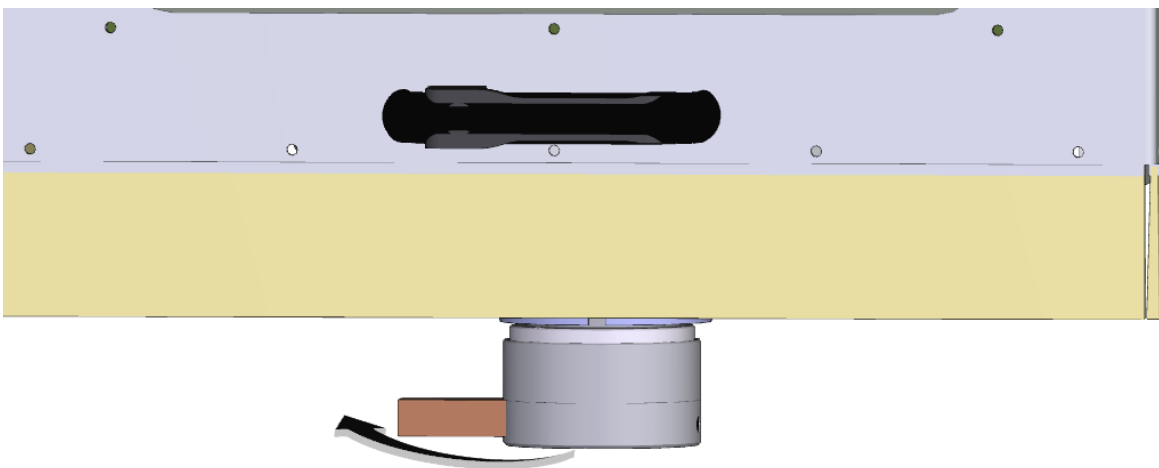

Now turn the cutterhead counterclockwise. You will feel an increase of resistance as the spring load of the inner spindle increases. Continue to tighten until there is a sudden increase in effort to turn the cutterhead. At this point the inner spindle washers are fully compressed.

**⚠ CAUTION** *IMPORTANT: DO NOT OVER TIGHTEN, SEVERE BEARING DAMAGE WILL OCCUR AND REPLACEMENT WILL BE NECESSARY*

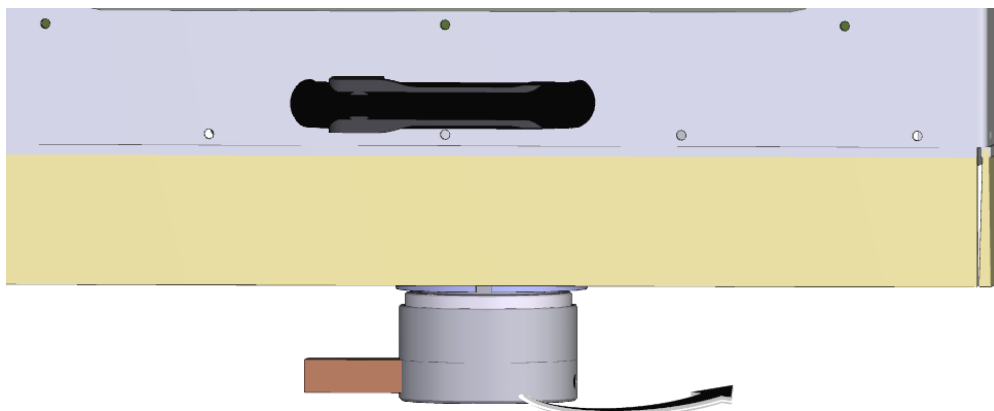
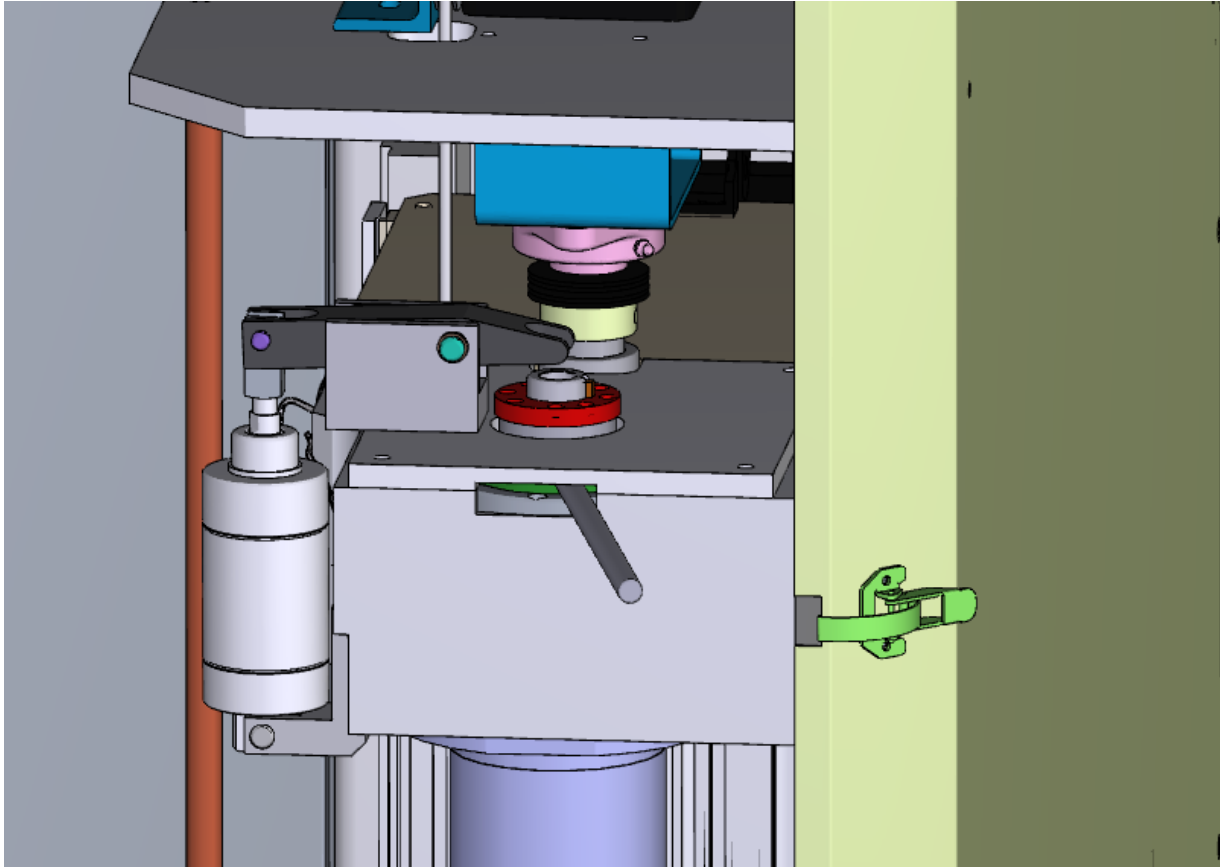

Now turn the cutterhead clockwise until you feel the detent ball on the adjusting nut lock into place. The inner spindle is now adjusted. Remove the rod from the adjustment nut and close the spindle cover door.

## F103/4/5M Upper Housing Disassembly

Travel the machine to the right Home position.

Remove the spindle base door and right side cover.

Place a board across the spindle base directly below the spindle motor (6790K or 6790U). Lower the spindle until the motor just touches the board.



Disconnect all power and air to the machine before continuing, severe bodily injury may occur.

Remove the four (4) bolts securing the motor the belt housing. Remove the two (2) bolts that secure the cable carrier (6314K) to the upper housing. Remove the oil and air lines from the upper housing.

**Note: It is not necessary to disconnect the spindle motor wiring.**

Rotate the vertical ballscrew by hand until it is about eight (8) inches from the top plate.

Place a board, of proper length, between the bottom of the upper housing and the top of the spindle base to prevent it from falling.

Remove the two bolts that secure the centering gear housing (6168H) to the belt housing. Work the centering housing up off the centering shaft. Tie it up to the top plate.

**IMPORTANT!!: Do not attempt to move the vertical under power when the centering housing is not bolted to the belt housing or the upper plate. Severe damage will result to the centering shaft!!**

Remove the Clevis Pin (7210B) from the draw bar actuator bracket (6174B). Lift the actuator arm (6173B), move the arm and cylinder off to the side. Remove the air cylinder (6204A), clevis pin (6189A) and mount bracket (6188C) from the side of the belt housing. Remove the two (2) bolts that attach the draw bar actuator bracket (6174B) to the to belt housing cover.

Remove the counter weight cable (6453 F or 6453G) from the upper housing by loosening the lock nut and unscrewing the cable nut.

**Note: When reassembling, be sure not to thread the cable nut in too far as it may come in contact with the driven pulley.**

Remove the eight (8) screws holding the inner spindle end cap (6180A). Unscrew these bolts slowly around the diameter of the end cap as they are under spring pressure from the draw bar. Remove the cap by pulling straight up.

**Note: When reinstalling, the end cap must be aligned concentric to the draw bar.**

Remove the three (3) screws that secure the vertical ballscrew nut to the belt housing. Holding the nut with one hand, turn the ballscrew with the other to move it up and out of the way so the belt housing lid can be removed.

Remove the bolts securing the belt housing covers. The covers are pinned to the belt housing. Use a soft face mallet to carefully remove the covers.

From this position you can remove and/or replace pulleys and belts.

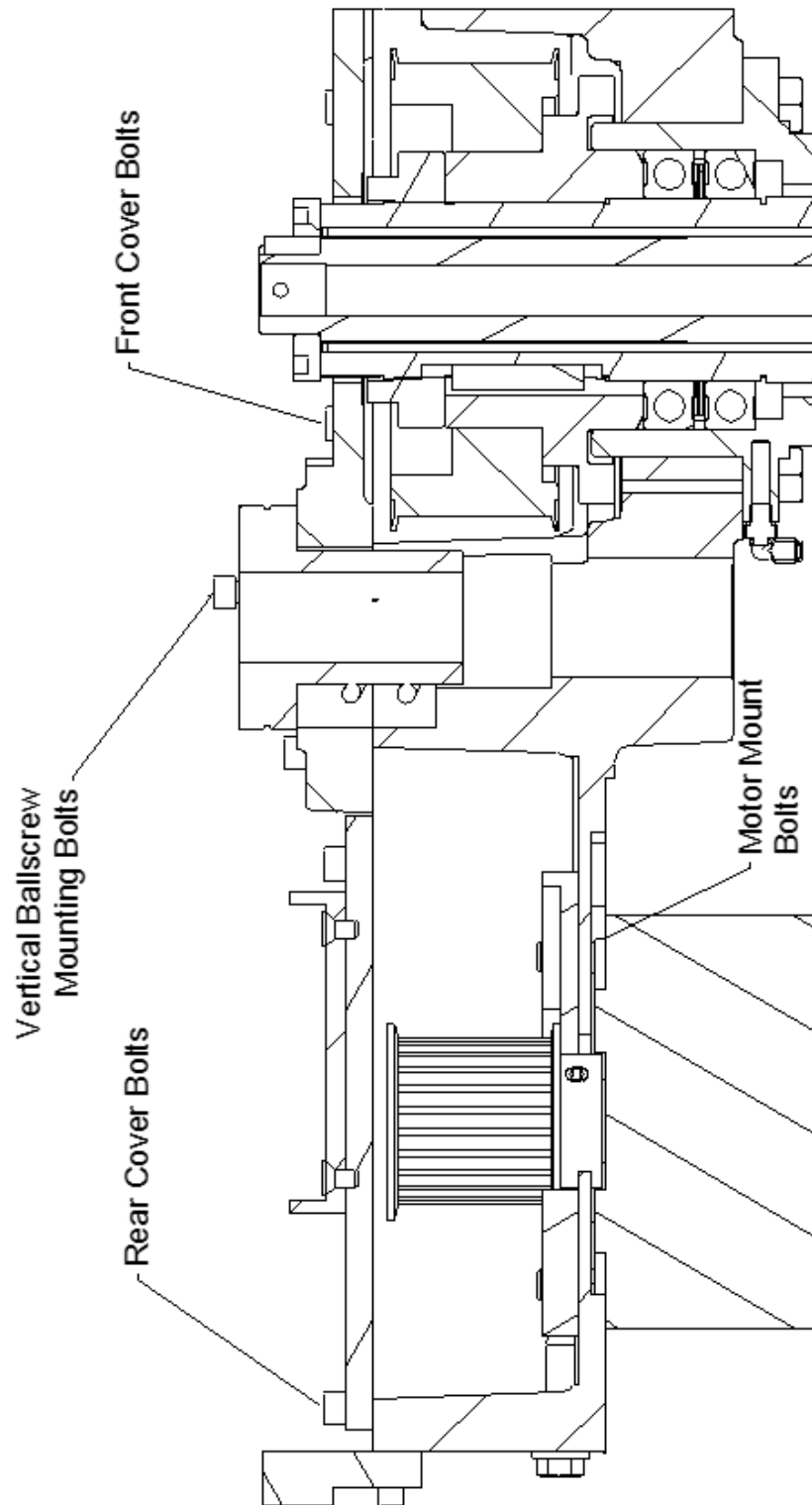

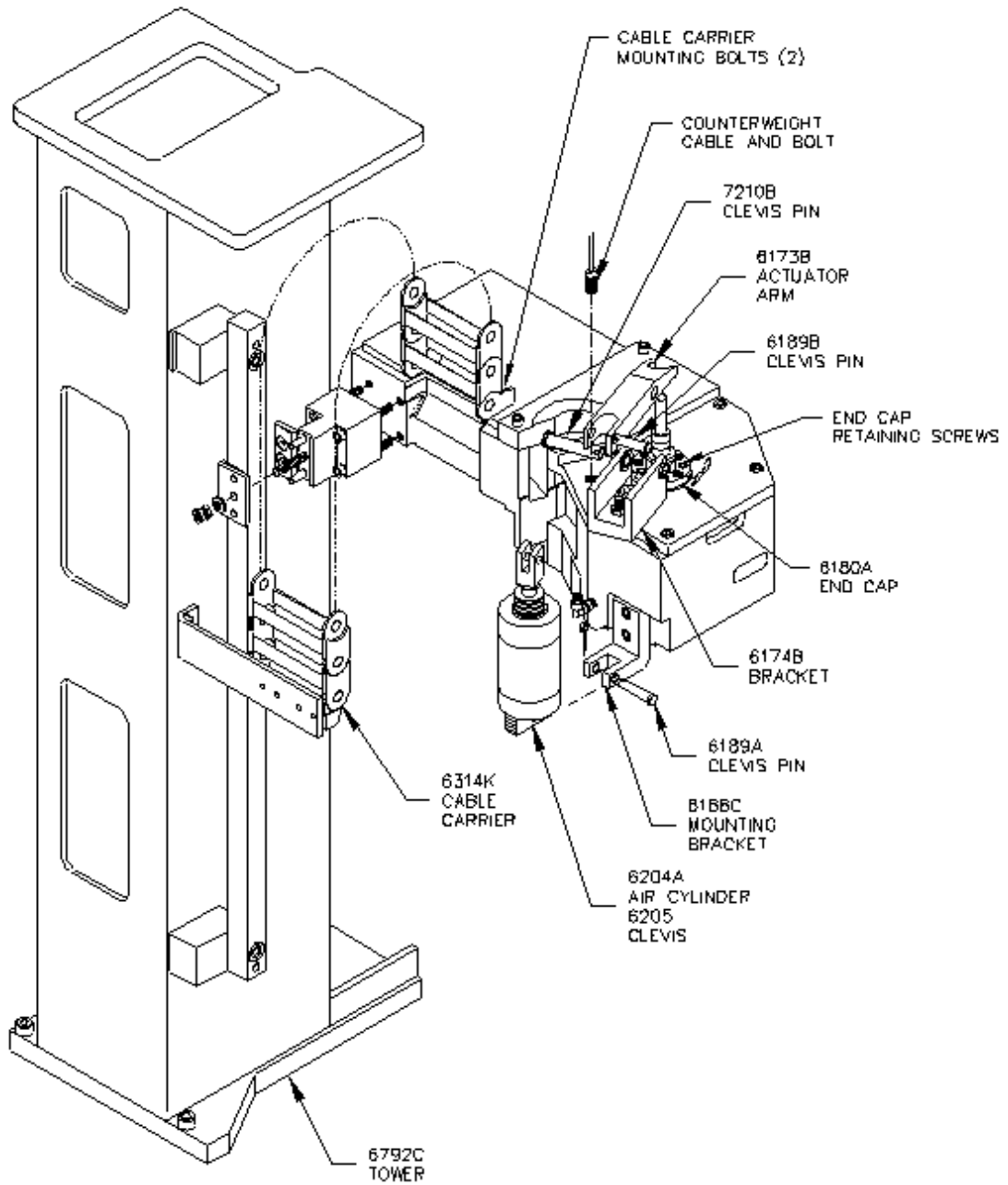

### F103/4/5M Inner Spindle Removal

Prior to following these instruction, perform the steps in Upper Housing Disassembly.

**IMPORTANT: When removing bearings, bellevilles and spacers, not the direction they come off for correct reassembly.**

The driven pulley and inner spindle adjustment nut must be in place before continuing. Remove the LEFT HAND THREAD throwback ring (6305D) from the bottom of the outer spindle.

**Note: If the driven pulley and inner spindle adjustment nut are not in place the inner spindle will be able to fall out of the outer spindle.**

While supporting the inner spindle from the bottom, remove the inner spindle adjustment nut and driven pulley from the top.

The inner spindle is now free to be removed from the bottom. This spindle is precision fit into the outer spindle, it may be necessary to tap the top of the inner spindle with a soft face mallet to get the spindle to drop out.

**Note: Be sure of the thrust direction of the bearings on reassembly.**

Reassemble in the reverse order.

### Inner Spindle Angular Contact Bearing Replacement

Prior to following these instruction, perform the steps in Upper Housing Disassembly and Inner Spindle Removal.

Loosen the three (3) Allen head set screws on the shoelock nut (6116F).  
Loosen the shoelock nut and slide off of the top of the spindle.

**Note: Be very careful not to damage the threads when sliding nuts, bearings and sleeves off the top of the inner spindle. These are very fine threads used for the inner spindle adjustment nut.**

Remove the top bearing by tapping lightly and evenly on both sides of the bearing. After the bearing is moved slightly off of the spacer set (6172E) tap the inner race.

**Note: Tapping on the outer race can cause it to roll off of the bearings. Generally after removing the bearings from the inner spindle they are not suitable for re-use.**

Remove the spacer set.

Remove the two lower bearings (6116E) set of three (3) the same way as the top bearing.

Stand the spindle on end so that the bearing pack is nearest the floor.

Make sure inner spindle is free of all dirt and debris.

Lightly coat the lower bearing pack area with a light weight #10 oil.

If you have a bearing heater available to you, it is the preferred method of bearing installation. If not, follow the instructions below.

Slide the two (2) lower bearings onto the inner spindle with the correct bearing thrust direction until they stop. Use a small brass punch to lightly tap each side of the bearing on the inner race until both bearings are seated at the bottom of the spindle.

Install the spacer set.

Install the top bearing using the same procedure as the lower bearings until it is seated against the spacer set.

Install the shoelock nut and tighten with a spanner wrench until the inner races of the bearings and spacer set are fully seated together.

Tighten the three (3) set screws on the shoelock nut.

Place the inner spindle in a vise near the bearing pack and lock the vise.

Indicate the bearing set to within .0005" all the way around. Adjust the spacer set by tapping the high side lightly with a brass drift.

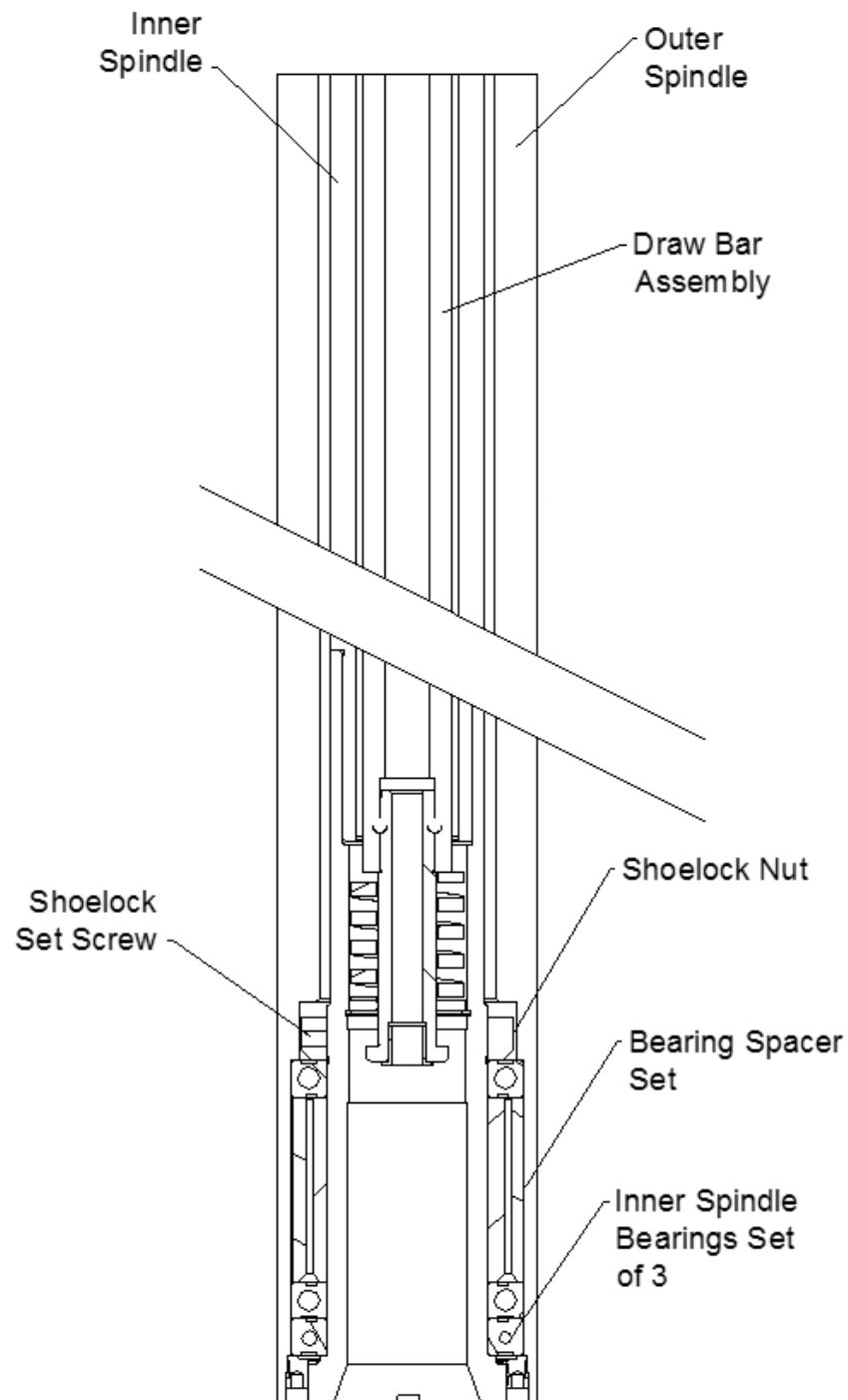



## Spindle Sweep

The outer spindle must be swept into the main bed of the machine to achieve accurate bores.

Remove all fixturing from the machine bed, clean and stone if needed.

Install a boring cutterhead into the machine.

Install the sweep are into the cutterhead.

Bring the machine down until you have about .005" pressure on the indicator.

**CAUTION** Disconnect all power and air to the machine before continuing, severe bodily injury may occur.

Turn the sweep arm to the 9 O'clock position. Zero the indicator here.

Loosen the 6 socket head cap screws on the lower spindle hub. You do not want them all the way loose, just snug.

Use the three (3) set screws in the spindle base to move the spindle until the indicator reads within .0005" with a full 360 degree sweep of the indicator.

**Note:** *You do not want the right hand side of the spindle to be more positive than the left, it will interfere with the automatic tilt of the machine when in Mill mode.*

Once the spindle is swept in tighten the six (6) socket head cap screws and double check that the sweep did not move.

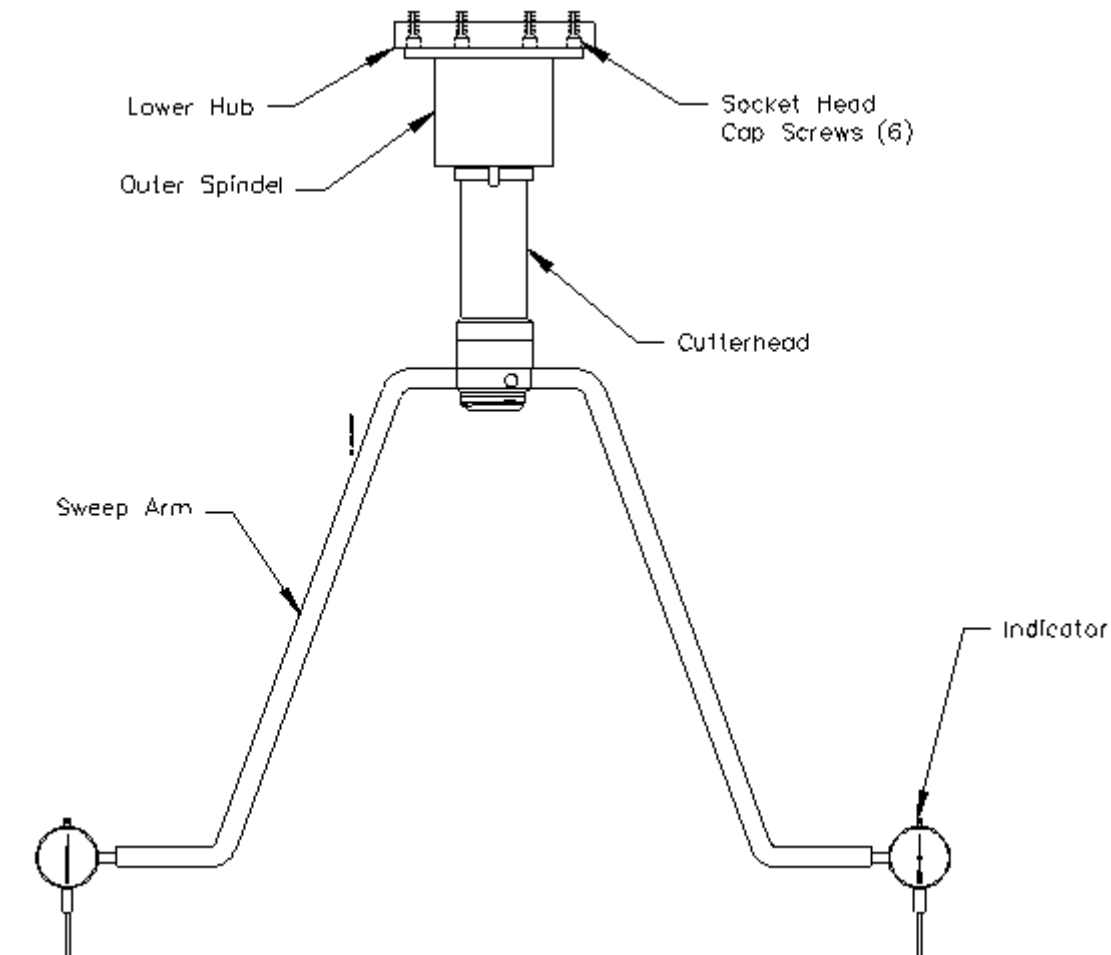

## Horizontal Gibs

The Horizontal gibs are located under the main column, on the back side of the front way. These gibs keep the column from “cocking” when the direction of travel is changed. This adjustment becomes more critical when line boring. If the gibs are too loose the column will turn slightly side ways when traveling. This will cause the alignment of the right angle drive to be off. The cutterhead will then cut heavier on one side of the bore.

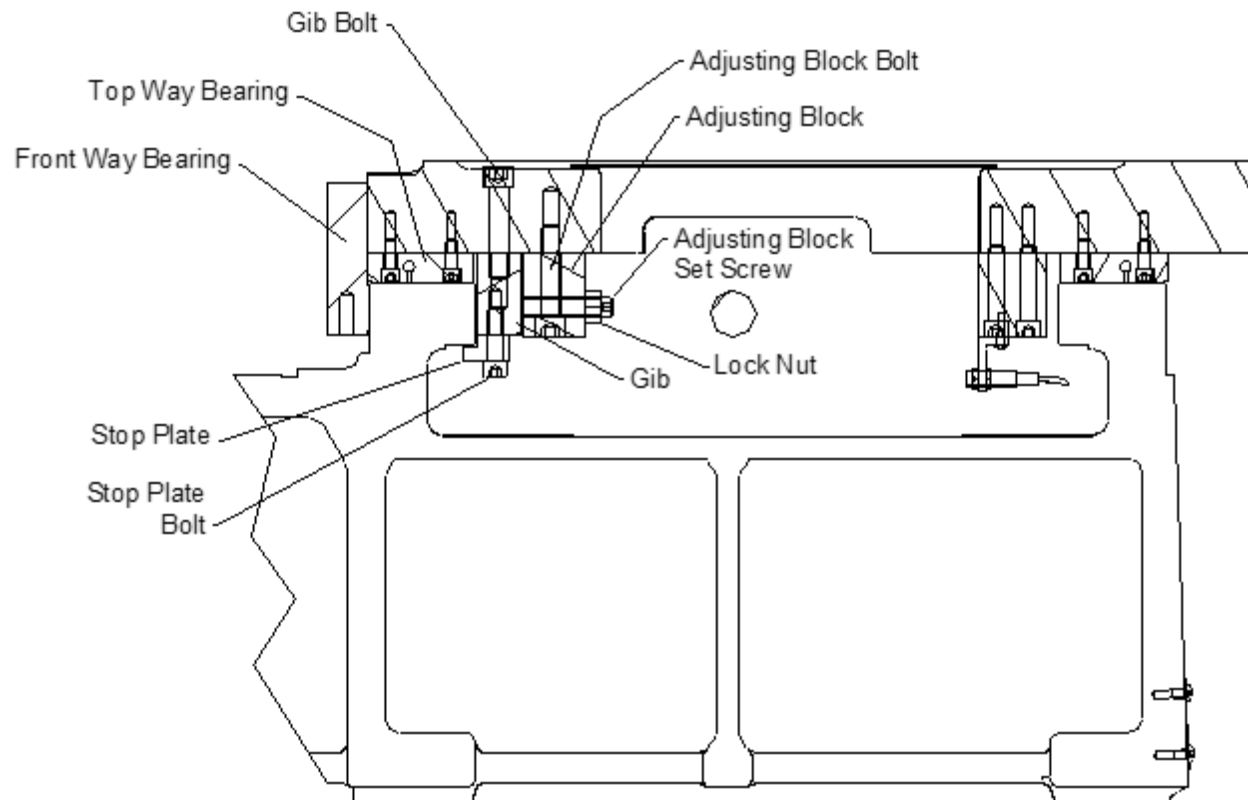

### To adjust:

Loosen the Gib bolts (two on each side)

Loosen the Lock Nut on the set screw.

Tighten the set screw as much as possible using only the correct size Allen Wrench. This will pull the Front Way bearing up against the front way while pressing the Gib up against the back of the Front Way.

Loosen the Set Screw.

Tighten the set screw up until you can feel it contact the Gib.

Lock the Lock nut.

Run the machine back and forth to let the gibs adjust to adjust in.

Tighten the Gib bolts. Torque to 5 ft. lbs. or 60 in. lbs.

If the machine will not travel full speed or the handwheel movement is erratic the gibs may be too tight. Re-adjust leaving the Set Screw a little bit looser than the previous adjustment.

Another way to check for correct adjustment is to attach a magnetic base dial indicator (.0001 resolution) to the column with the indicator tip contacting the machine way surface.

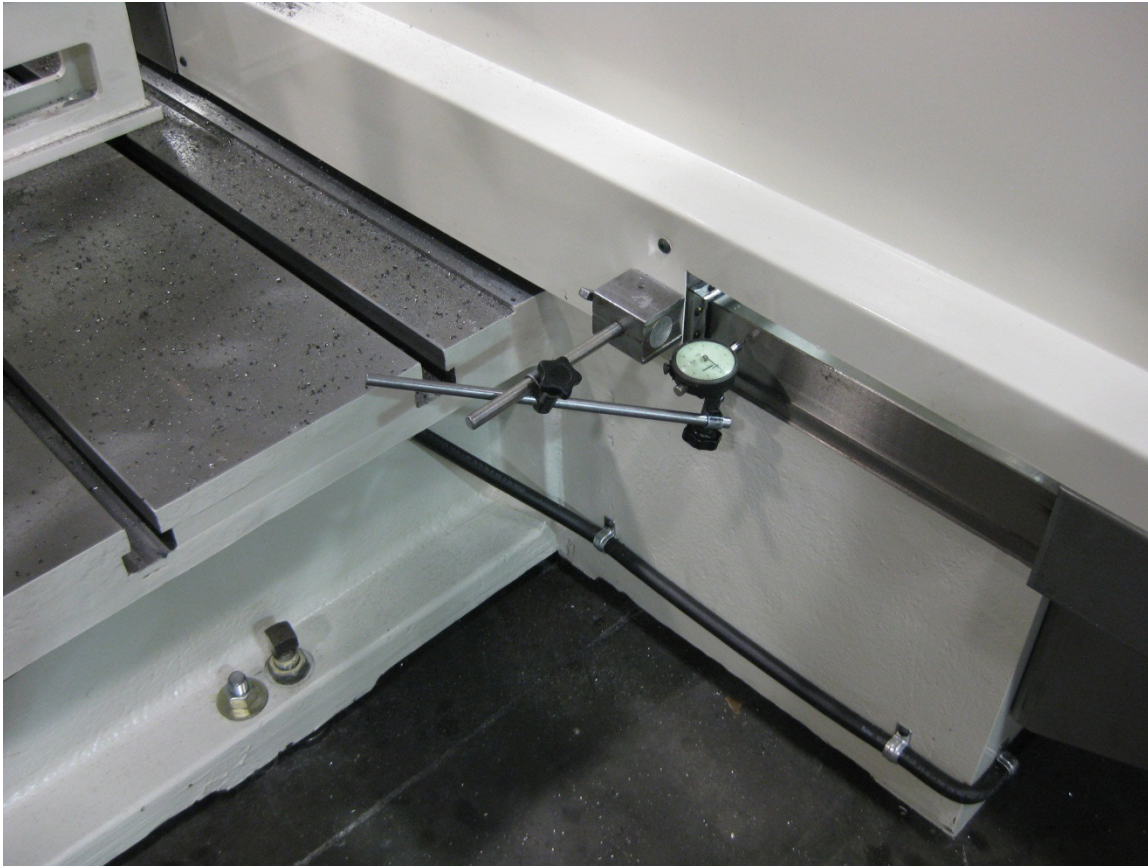

Now using the handwheel in .010" per click mode, move the column back and forth, about two turns on the handwheel in each direction at a rapid rate.

Note the amount of movement on the dial indicator.

The acceptable amount of movement on the dial indicator is between .0002"-.0005".

Adjust as necessary. This procedure must be performed at both, the right, and left, sides of the column.

## Adjusting Y-Axis Gibs

The Y-Axis adjusting gibs are located at the top of the machine column that the spindle base is mounted on. There are gibs located on the top and side rails on the left side of the column. Two are located on the top rail and two are located on the side rail.

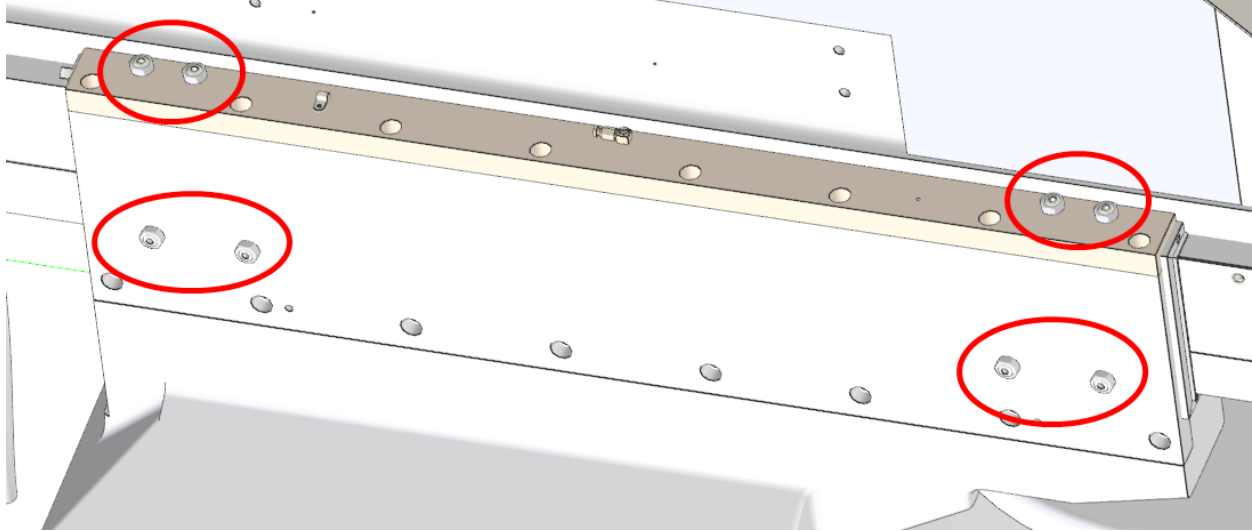

On the right side of the column there are gibs located on the top rail.

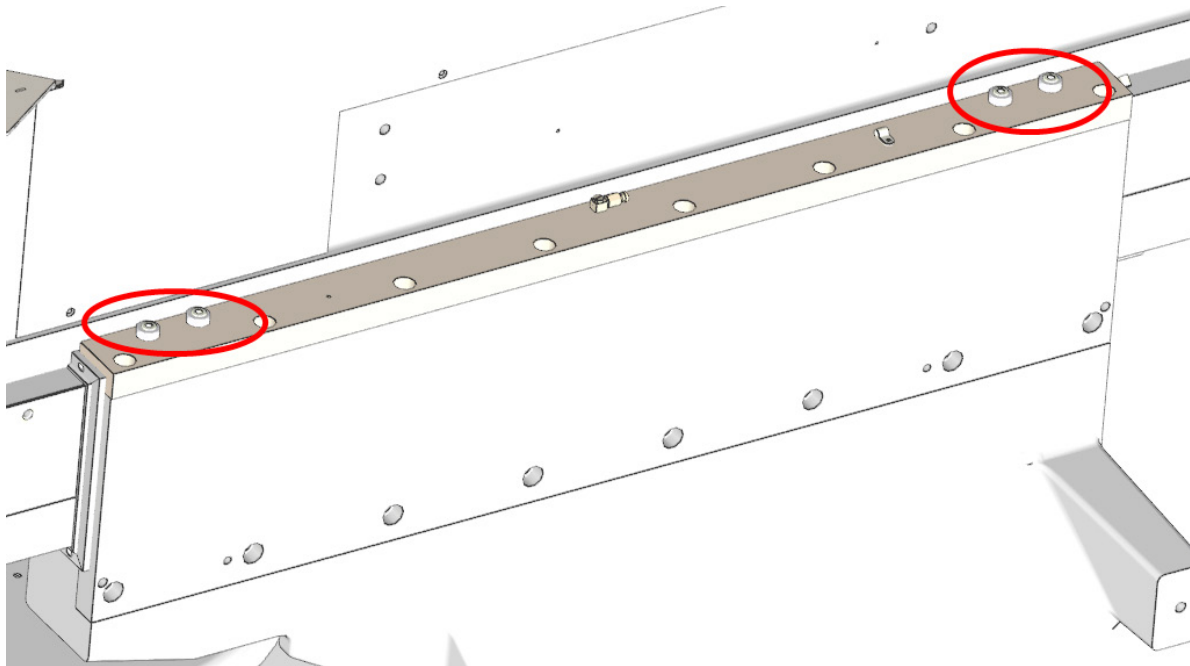

**Adjustment Procedure**

1. On the left side rail loosen the jam nuts.
2. Tighten the set screws until they bottom out and can't be turned further.
3. Loosen each set screw 1/8 turn.
4. Tighten jam nuts.
5. On both top rails loosen jam nuts.
6. Tighten the set screws until they bottom out and can't be turned further.
7. Loosen each set screw 3/4 turn.
8. Tighten jam nuts.

## Backlash Setting .NET Software

The Screens depicted below are for setting **Backlash** compensation values only. **DO NOT** use any other information on these screens to change information on the machine.

1. Turn off "Overshoot Backlash Setup"

**Note:** Only the F70-90 and 100 machines use the overshoot feature.

Go to Setup Software>Addins>Overshoot Backlash Setup

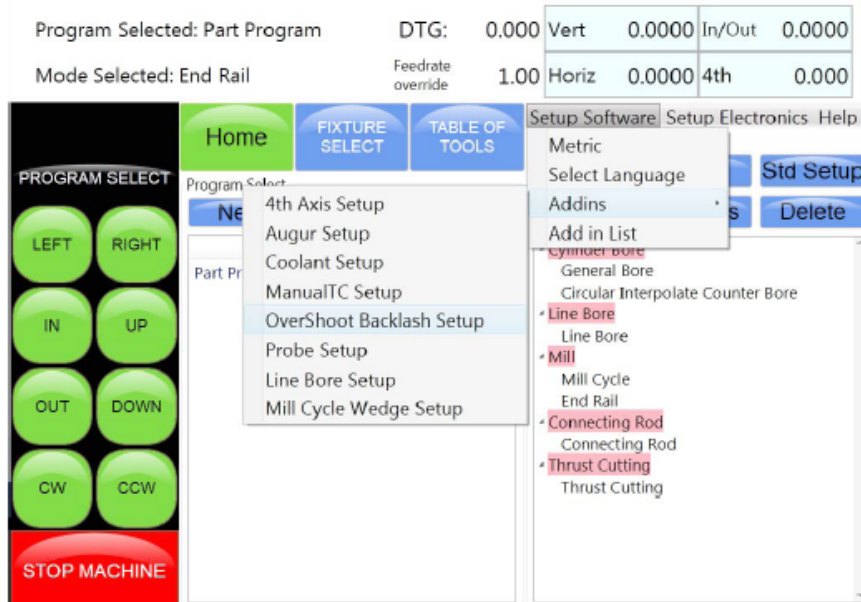

The Following screen will appear.

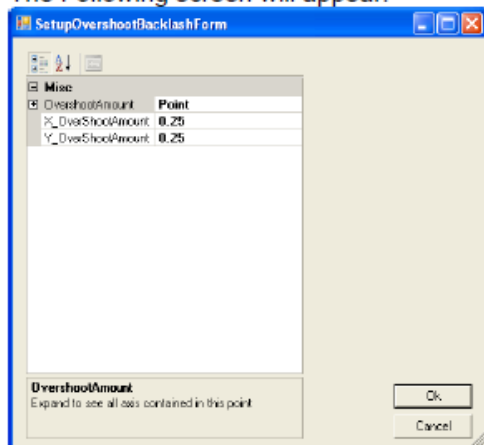

1. Record the existing X and Y "Overshoot Amount". Generally .250
2. Use the "On Screen Keyboard", or plug in the full size keyboard, and change the amounts to 0.00, and click on OK. Close the "Setup" screen.

3. Go to Setup Electronics>Control

Program Selected: Part Program      DTG: 0.000      Vert 0.0000      In/Out 0.0000

Mode Selected: End Rail      Feedrate override 1.00      Horiz 0.0000      4th 0.000

The screenshot shows a CNC control interface. On the left is a 'PROGRAM SELECT' panel with buttons for LEFT, RIGHT, IN, UP, OUT, DOWN, CW, and CCW, and a red 'STOP MACHINE' button. In the center is a 'Control Options' dialog box with a table of ControlOptionsForm and LinkNumber values. On the right is a 'Setup Software' menu with 'Setup Electronics' selected, showing a 'Control' submenu with options like Coordinated Motion and IO. Below the menu is a list of tool types including Cylinder Bore, Line Bore, Mill, Connecting Rod, and Thrust Cutting.

ControlOptionsForm	LinkNumber
X	0
Y	1
Z	2
Handwheel	-1
S	3
A	-1
Outputs	6
Inputs	5

Control Options

Setup Software Setup Electronics Help

Mode Select Control

Select Coordinated Motion IO

- Cylinder Bore
  - General Bore
  - Circular Interpolate Counter Bore
- Line Bore
  - Line Bore
- Mill
  - Mill Cycle
  - End Rail
- Connecting Rod
  - Connecting Rod
- Thrust Cutting
  - Thrust Cutting



4. On the "Control Options" screen, double click the X to bring up the "X Options" screen.

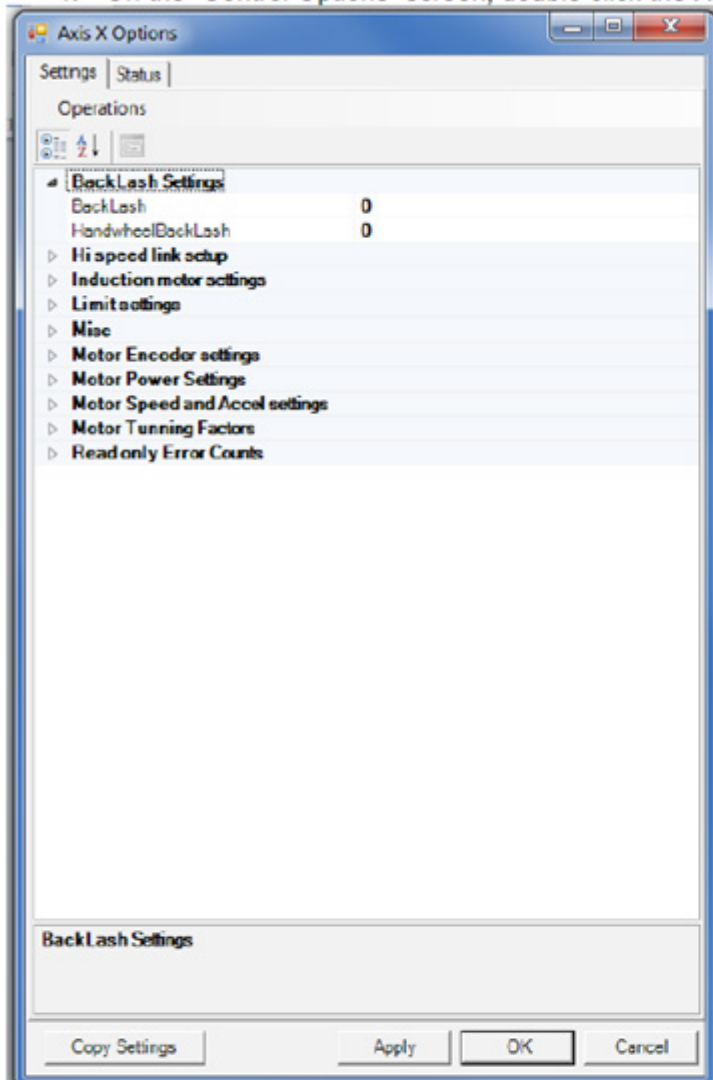

Now minimize the screen.

5. Repeat step 4 for the Y and Z axis.
6. Close the "Control Options" screen.



7. Select a program (block), then select any cylinder bore mode.

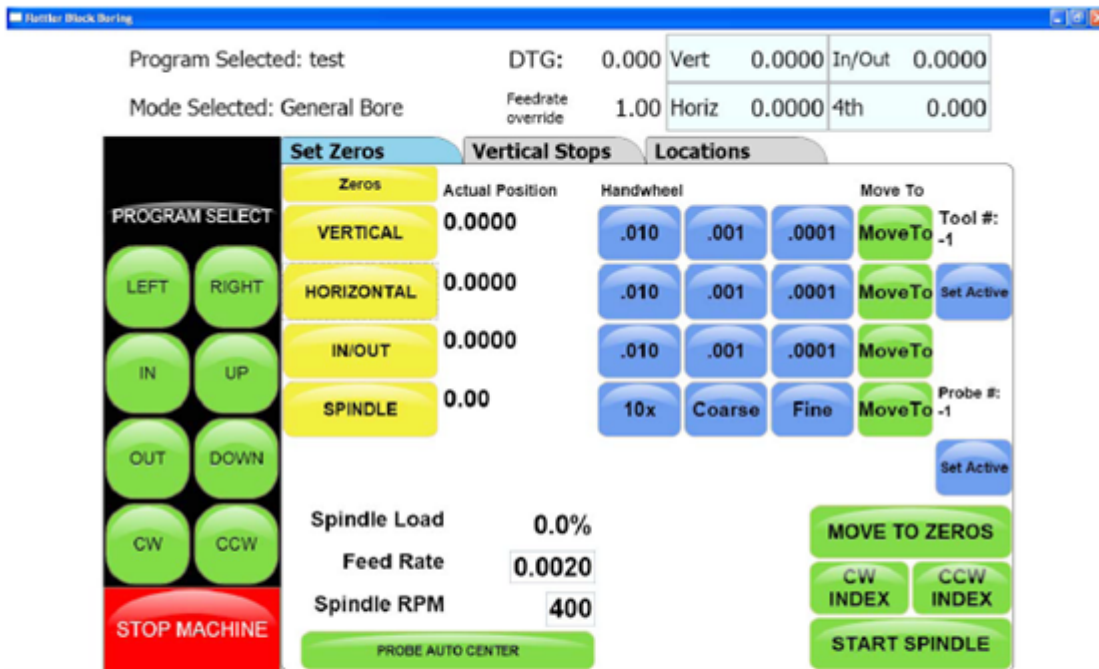

**Notes:**

\*\*\*The photos shown are demonstrating the X axis (horizontal) backlash adjustment. The Y and Z axis are adjusted following the same steps.

\*\*\*The direction of machine travel to put the initial load on the dial indicator, are as follows:

X (horizontal), from the right toward the left.

Y (in/out), from back toward the front.

Z (vertical) from top toward the bottom.

A Dial Indicator with 1.0" to 1.5" of travel should be used for several reasons.



If the axis is overshooting or coming to position slowly you will be able to see it with a dial indicator. With Digital indicator you will only see the end position. The Magnascale indicator should be used to dial or tram in. The automatic moves of the machine can "Shock" the sensitive plunger of the Magnascale.

8. Attach the magnetic base and dial indicator to a stationary stand, parallel, or engine block fixed to the machine bed.

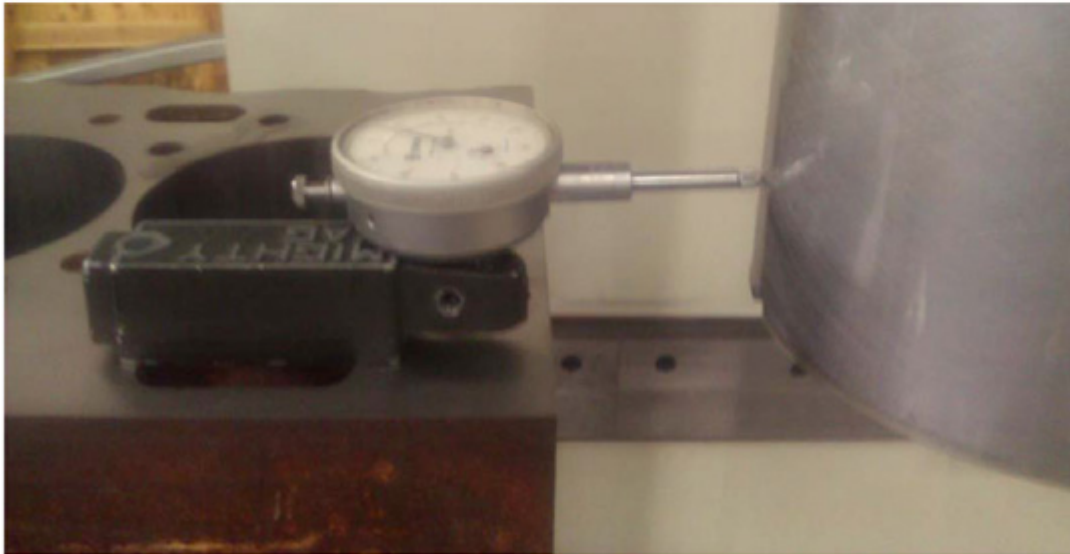

9. Bring the spindle of the machine in position to put a slight load on the Plunger, about .020".

10. Set "Vertical, Horizontal, In/Out" zero.

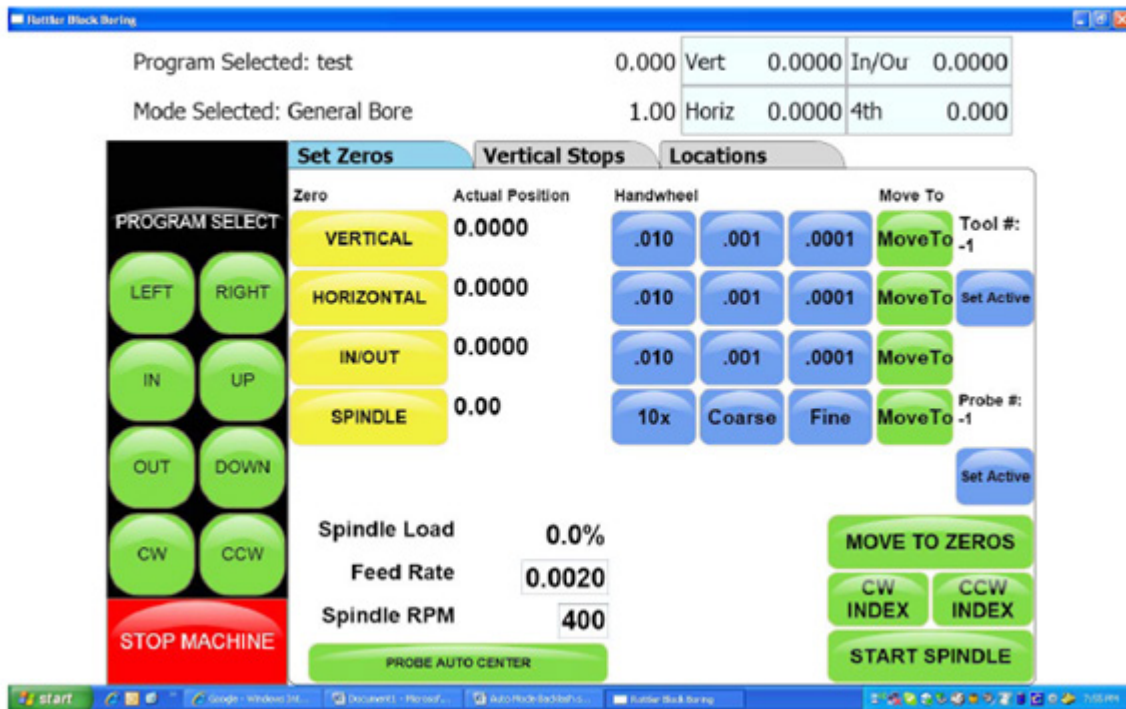

11. Set all vertical stops to "zero".

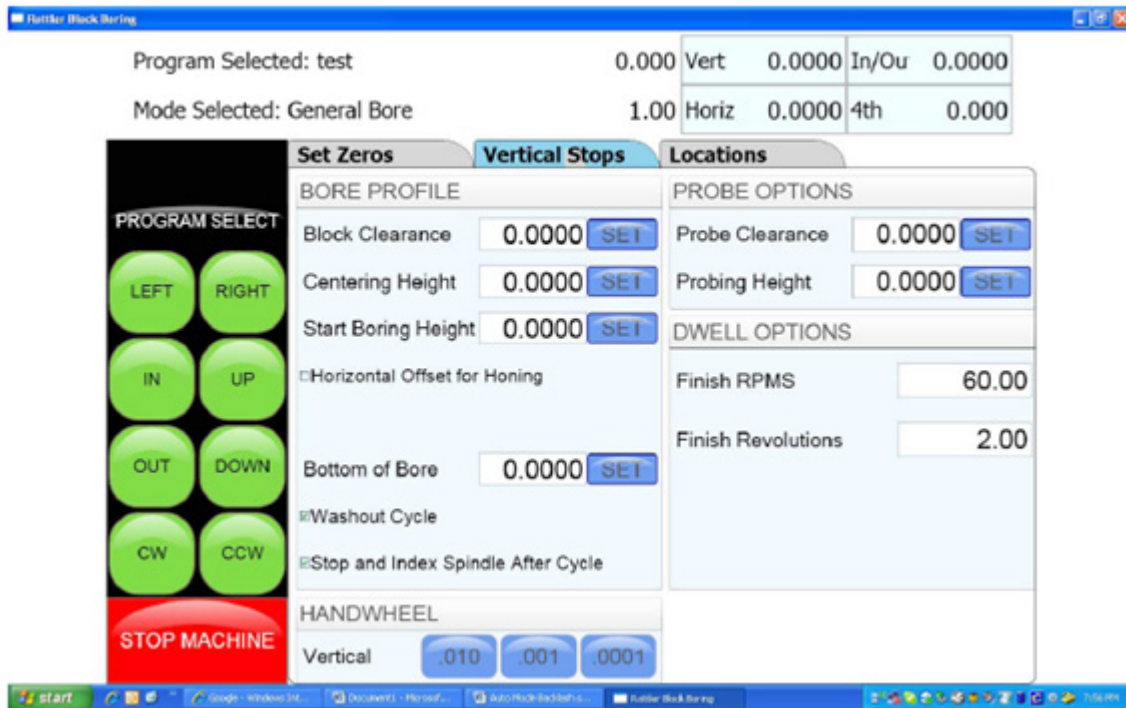

12. Move the machine spindle away from the Plunger a few inches, and press "Move to" and then 0 and Enter from the pop up keypad for the axis that is being measured..



13. Repeat the movement to verify the machine will repeatedly position itself at zero.  
 14. Now, use the "Move To" button and then -.200 to move the spindle -.200" in the opposite direction.  
 15. Press "Move to" and then 0 and Enter from the pop up keypad for the axis that is being measured..

If the machine did not position itself to bring the digital readout to zero, a backlash compensation adjustment is needed.



16. To adjust, maximize the "Axis X Options" screen. Go to Backlash Setting>Backlash.

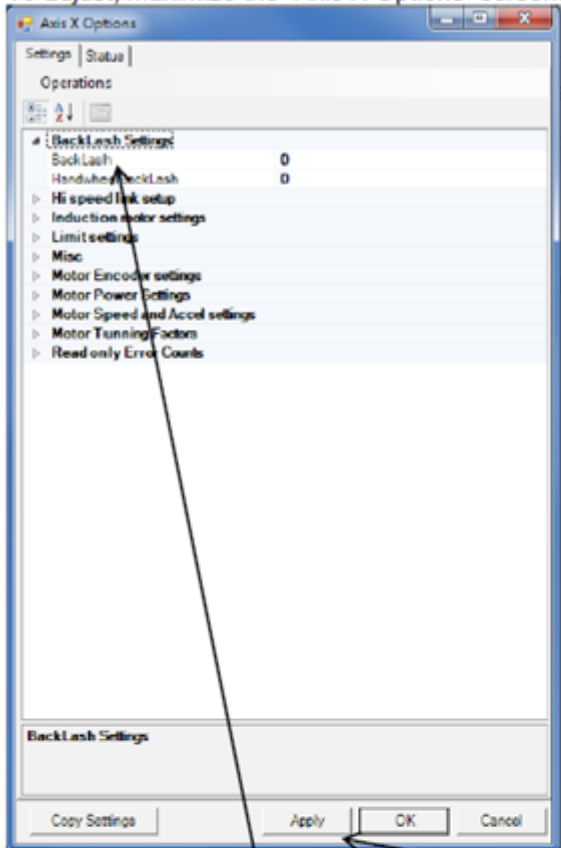

17. Use the "On Screen Keyboard", or plug in the full size keyboard to enter the amount of correction in the Backlash area. After entering a value, click "Apply", for the new setting to take effect.
18. Repeat steps 13 through 17 and adjust as necessary until the machine positions itself to "Zero" on the digital readout from both directions.

Handwheel Backlash is measured in a similar way to Backlash but the axes is moved by the Handwheel – the Move To buttons are NOT used.

19. Set up the Dial Indicator as described in #8 and #9.
20. Touch the .001" Handwheel button and move the axis to away. Turn the handwheel at a **constant speed** and move the axis back until the control panel displays zero. If the axis travels past zero, start again - move back again and turn the Handwheel at **constant speed** until the axis stops on zero on the machine display. Check that the Dial Indicator is zero, if not, move away and back again until both the machine control and Dial Indicator both read zero.

21. Now move the axis in the opposite direction and be sure to stop about .020" less that total plunger travel before compressing the plunger all the way. Now move the axis back by turning the Handwheel at a **constant speed** until the machine display reads zero. Check the reading on the Dial Indicator.
22. Use the "On Screen Keyboard", or plug in the full size keyboard to enter the amount of correction into Handwheel Backlash. Press Apply when you are done.

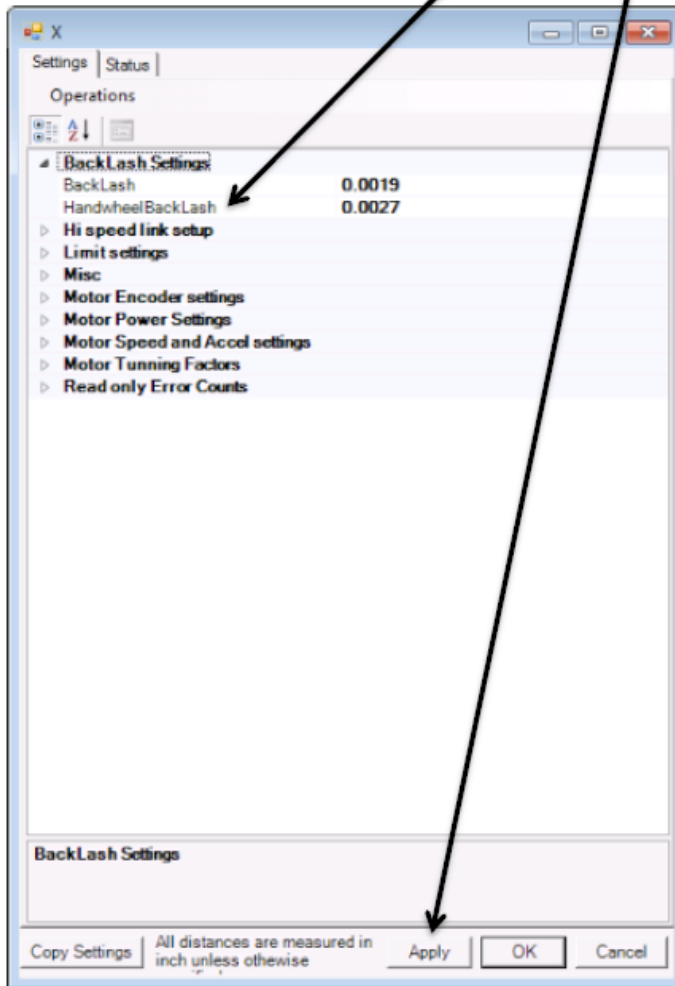

23. Follow steps 9 through 22 for the Y and Z axis.
24. When finished, re-enter the "Overshoot Backlash Amounts", as recorded in step 2 and click OK and close the window.

## Spindle Belt Adjustment

The spindle belt should not require adjustment very often, but if required use the following instructions.

Open the Spindle Base shroud.

Loosen the four Motor mounting bolts on the spindle motor.

Tighten or loosen the Tension adjustment bolt on the rear of the belt housing until 5 pounds of pressure causes the spindle belt to deflect 1/4".

If the spindle motor is run at high speed and a high pitched whining is heard from the belt housing area the belt adjustment is probably too tight.

If you can visually see the belt jumping around while running the belt is too loose.

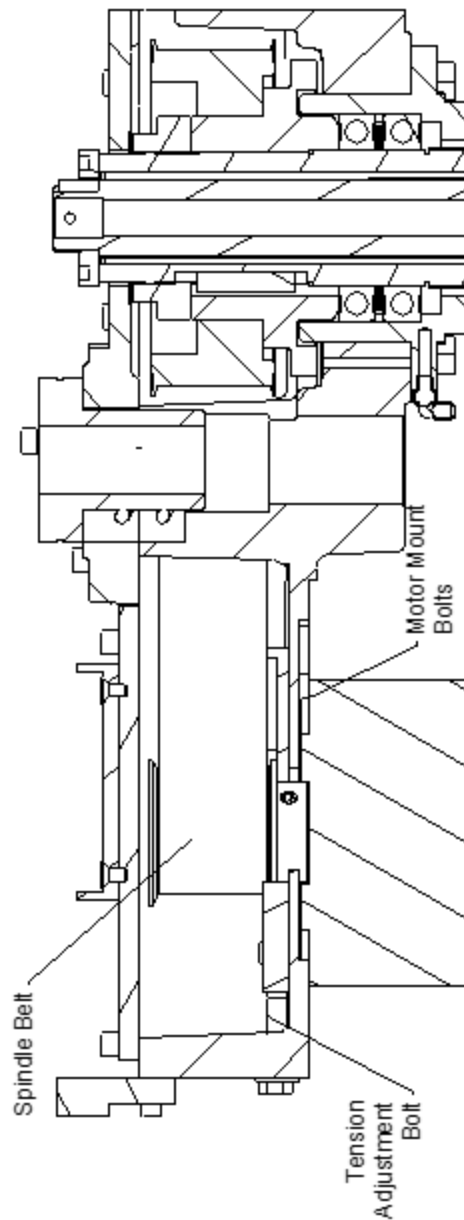

### Top and Side Rail Adjustment

1. Loosen jam nuts on side rail adjustment screws
2. Tighten adjustment screws until they bottom out
3. Back adjustment screws out 1/8 of a turn
4. Tighten jam nuts

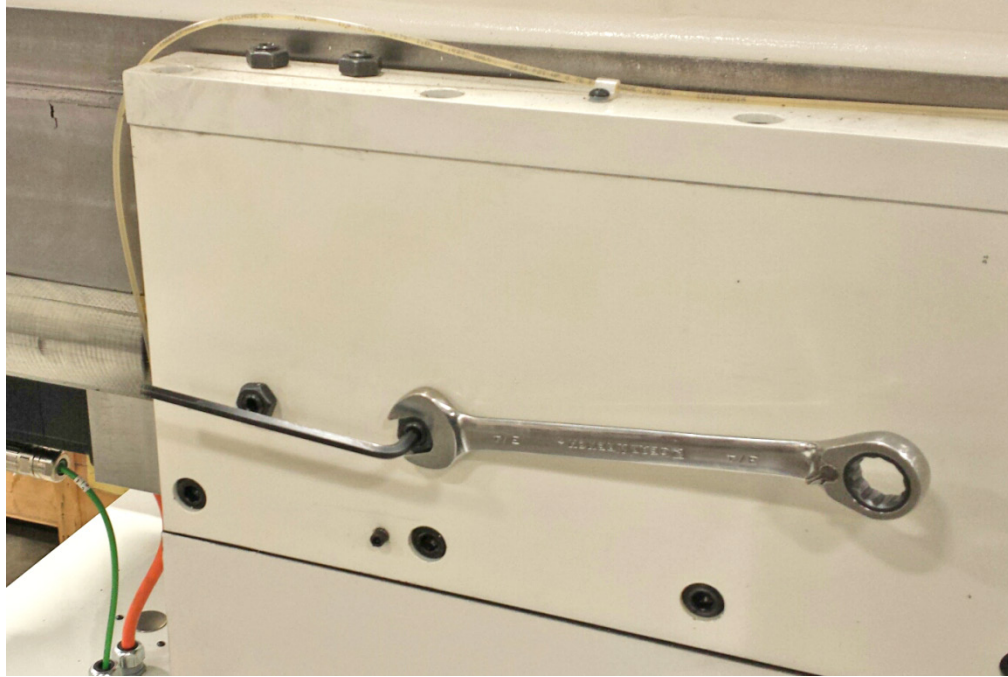

5. Loosen jam nuts on top rail adjustment screws
6. Tighten adjustment screws until they bottom out
7. Back adjustment screws out 3/4 of a turn
8. Tighten jam nuts





### Mill Tilt Adjustment Procedure

1. Position the Y axis in the middle of its travel. Using a 5/32" hex key, loosen the locking set screw through the access hole in the right side guide rail



2. Put the machine in "Mill Cycle" mode, with the wedge turned off. Attach an indicator as shown in the following photo, and set to zero position.



3. Using a 3/16" hex key, turn the adjustment screw in or out to increase, or decrease, the amount of mill tilt. Turn the screw CCW to increase, or turn CW to decrease the amount as shown in the photo at step #2. After each adjustment, turn the "Wedge On", to check the amount. Set to .002" - .004" (.05mm - .1mm) of lift with the wedge turned on. Turn the wedge off to readjust, and then turn the wedge on to check the amount.
4. When finished, tighten the locking set screw as shown in the photo in step #1.
5. Repeat the procedure for the rear wedge.



6. After adjusting the rear wedge, re-check the front, to make sure it did not change.



### Checking Wear on Column Turcite Pads

Remove bolts holding way covers to column.

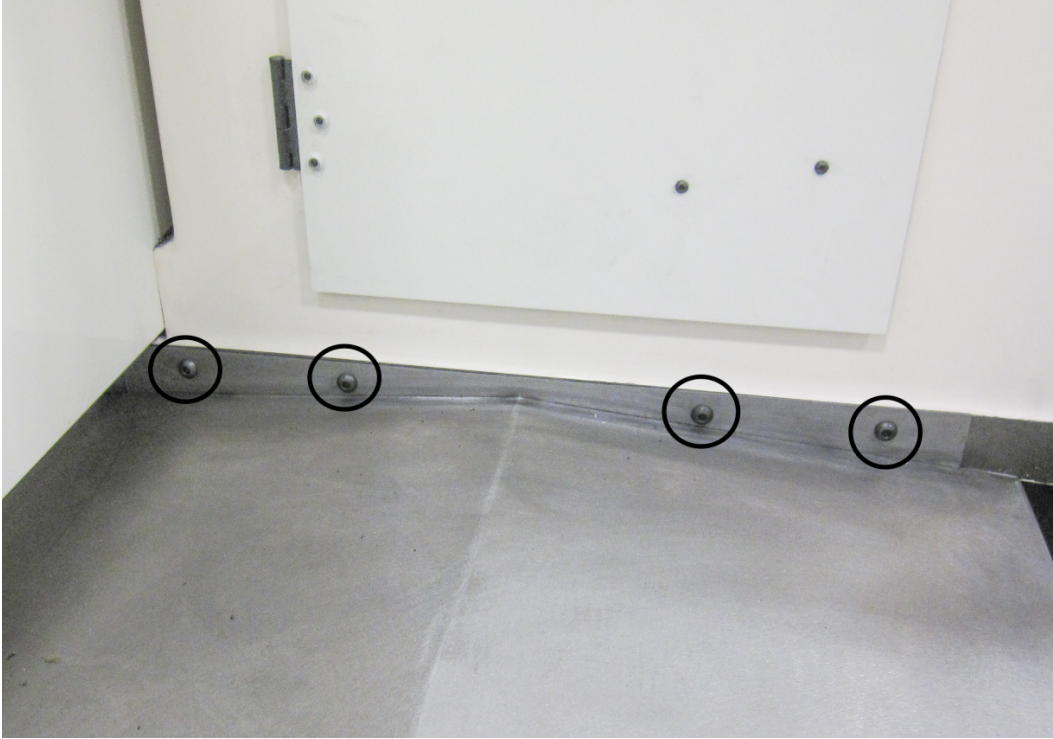

Slide way covers away from column to gain access to column way.  
Remove wipers from Turcite pads.

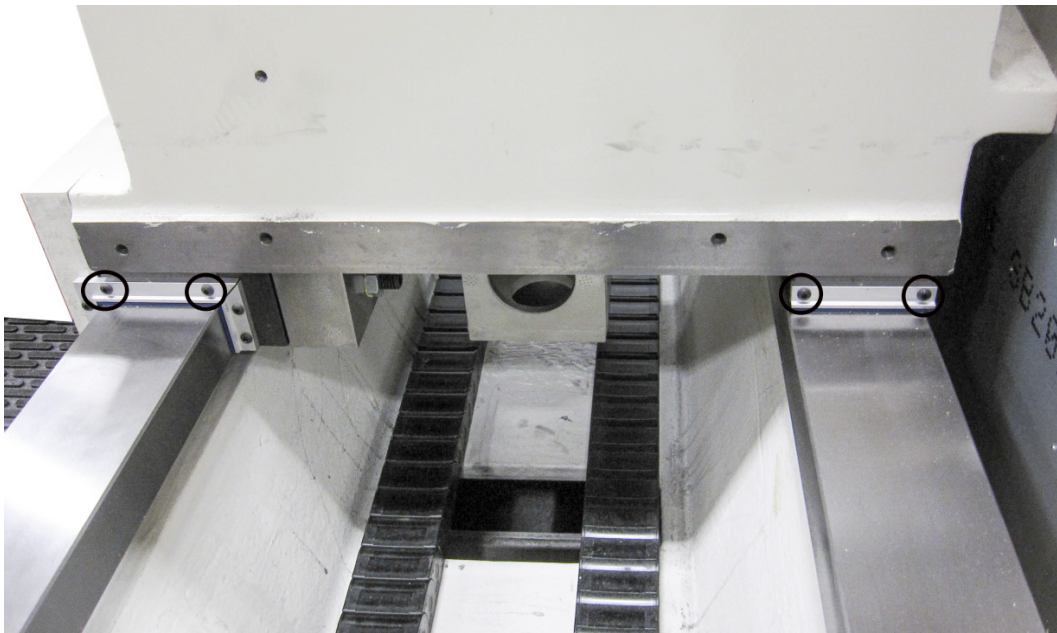

Measure height of Turcite pads using either feeler gauge or dial indicator method.

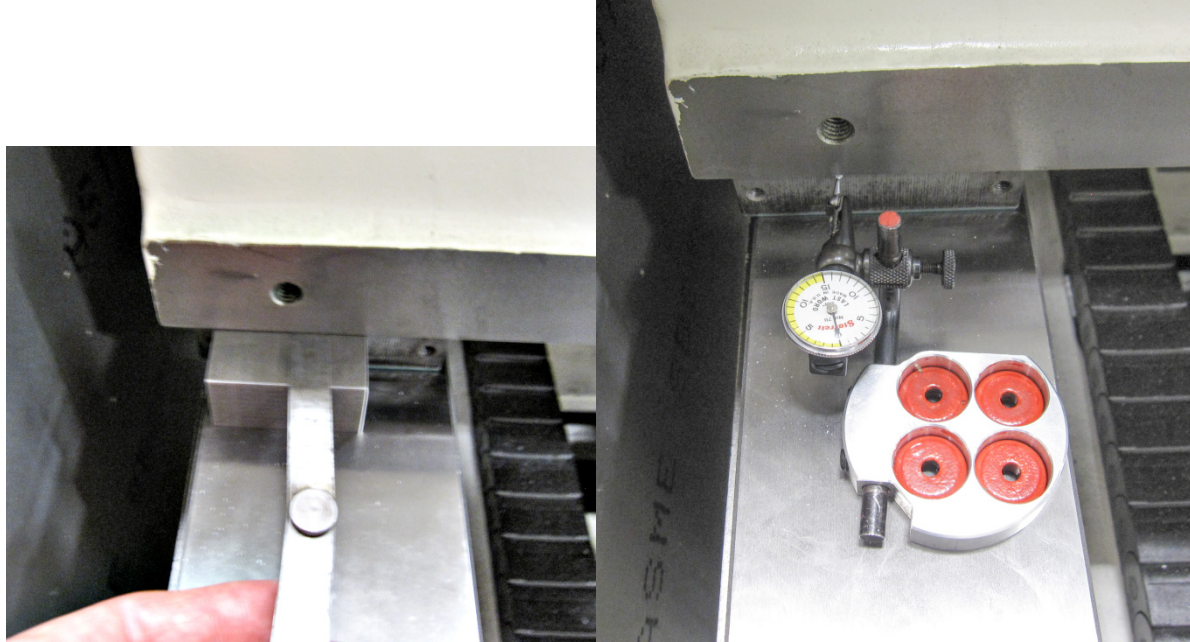

Pads will have to be replaced or shimmed if height difference between the 4 pads exceeds .005".

## Digital Micrometer setting instructions

Turn the thimble until the '0' line on the thimble lines up with the vertical line nearest the spindle lock ring.



Determine which cutter head bore range the micrometer is going to be used on. ( example; 2.9 – 6.0 )  
We want to initially set the micrometer to the minimum bore diameter of this cutterhead.

**NOTE: MICROMETER CAN NOT BE PROGRAMMED IF THE LETTERS INC APPEAR IN THE DISPLAY.** To get rid of INC, quickly press the in/mm/ABS button.



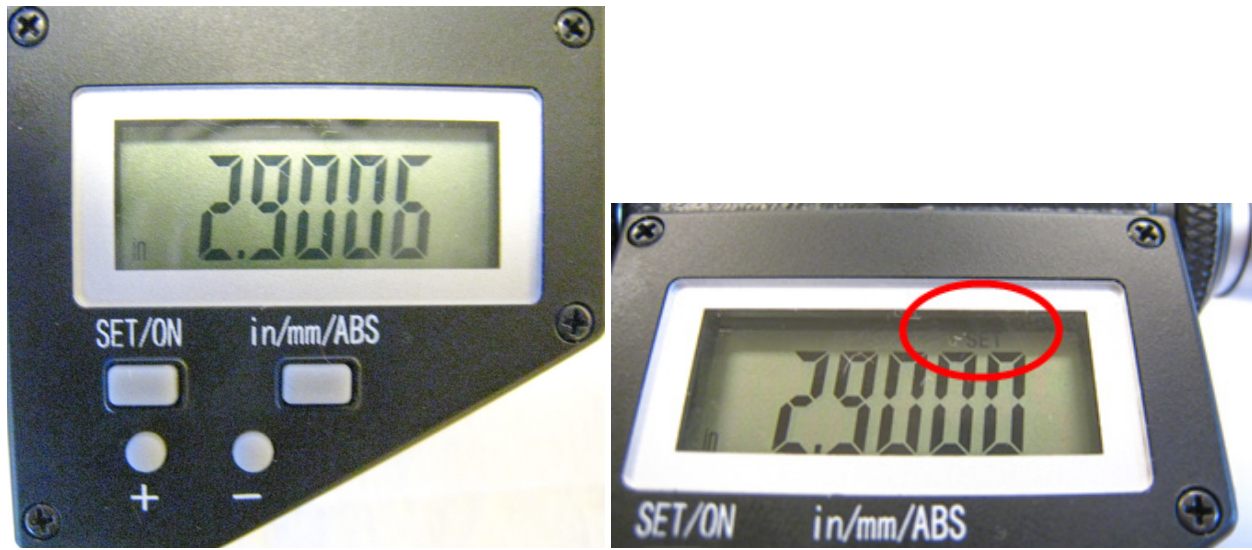

**To set or edit micrometer**

Press and hold the set/on button and the + or – button at the same time. “Set” will flash in the display. This places the micrometer in edit mode. (CAUTION: use a pencil tip or something similar to gently push the small round buttons - they are quite small and a bit delicate.)

Press and hold the + or – buttons to change the display number to the minimum bore diameter determined earlier (example; 2.9). Caution: Pushing the + or – buttons and holding in place will cause the numbers to scroll automatically. The numbers will count slowly at first and once 0.010” has been counted off the scrolling speed will pick dramatically.

After you have reached the desired number in the display, press the set/on button twice quickly to exit the edit mode. “Set” should no longer be flashing in the display. The micrometer is now ready for use.

CAUTION: AFTER MICROMETER SET-UP IS COMPLETE, DO NOT PUSH SET/ON BUTTON AGAIN. PUSHING THE SET/ON BUTTON DURING USE WILL RETURN THE DISPLAY TO THE ORIGINAL MINIMUM BORE DIAMETER. THE ONLY TIME YOU SHOULD USE THE SET/ON BUTTON AGAIN IS TO- A. To shut micrometer off at which time you push and hold the button or B. to turn micrometer display back on at which time you push button one time. The display will then show the last reading before micrometer was shut off.

CAUTION: DO NOT BACK THE THIMBLE ALL THE WAY OUT TO THE END OF IT’S TRAVEL. ONCE THE THIMBLE IS BACKED ALL THE WAY OUT, IT WILL NO LONGER ROTATE PROPERLY AND THE DIGITAL HEAD WILL NEED TO BE REPLACED.

Micrometer is calibrated in inch mode. If metric is desired, press and hold in/mm/ABS button until mode changes to metric (approximately 3-4 seconds). A quick press of the in/mm/ABS button will put micrometer in ABS mode: 0.000, with another quick press returning it to initial setting.

Set up the cutter head and bore a set up hole. Measure the bore accurately. Set the digital display to this bore dimension and then -

Loosen the set screw holding the large diameter anvil. Slide the anvil back out of the way.



Place the tool holder used to bore the hole into the micrometer frame. Slide the location nub on the back of the tool holder gently up against the end of the digital micrometer shaft.

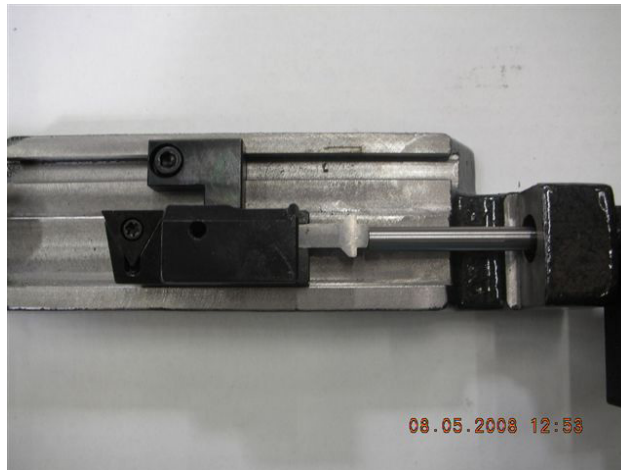

Slide the large diameter anvil up until it touches the end of the cutting tip of the tool holder. Tighten the set screw.

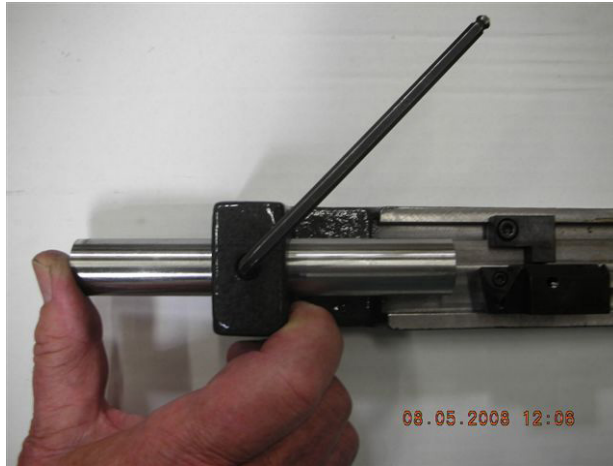

Back the digital micrometer shaft off, then bring it up to touch the tool holder and recheck that the numbers in the display are the same as the numbers previously shown.





The micrometer is now set up for use with this cutter head.

Note: this procedure must be repeated to set the micrometer to a different cutter head. The micrometer can only be set to one cutter head at a time.

To shut off micrometer press and hold set/on button until screen goes blank or let micrometer set until display disappears.

With initial setting of micrometer it is recommended that you use the procedure detailed below in the event you think you have size problems.



**Procedure:**

The short vertical lines that cross the horizontal scale on the micrometer sleeve are reference marks. Set the zero on the micrometer thimble even with the first vertical line and note the size shown in the digital display. Record this size for future reference. Now follow the same procedure for each line and record the sizes. At any time you feel your micrometer is reading incorrectly, you can quickly refer to the recorded size of the line closest to the range you are using and check that the micrometer is still accurate.

## Probe “On-Center” Adjustment

The optional shank adapter assembly allows the OMP40 to be mounted on shanks suitable for the MP10, MP12 and MP700 Probes.

### Step 1 - Adapter Assembly:

Assemble the 650-3-59H adapter plate as shown. Fully tighten screw A to 0.68 ft lb (3.0 Nm)

### Step 2 – Probe / shank Mounting:

Fully loosen all screws and fit shank adapter to shank as shown on the following page. Tighten screw B to 1.35 ft lb (6 Nm)

Fully tighten screw C to 0.49 ft lb (2.2 Nm)

Fit Probe / Shank assembly into machine spindle.

### Step 3 – Adjustment:

There are four screws D. Each will move the probe relative to the shank in the X or Y direction as pressure is applied. Tighten screw individually, backing off after each movement.

Use screws D in opposition at the same time to move the probe, progressively tightening then as the final setting is approached. Use two Allen keys if needed. Tip run out should be .002” (5 Microns) should be achievable.

It is important that all four screws (D) are tightened to 0.49 ft lb (2.2 Nm) once the final setting has been achieved.

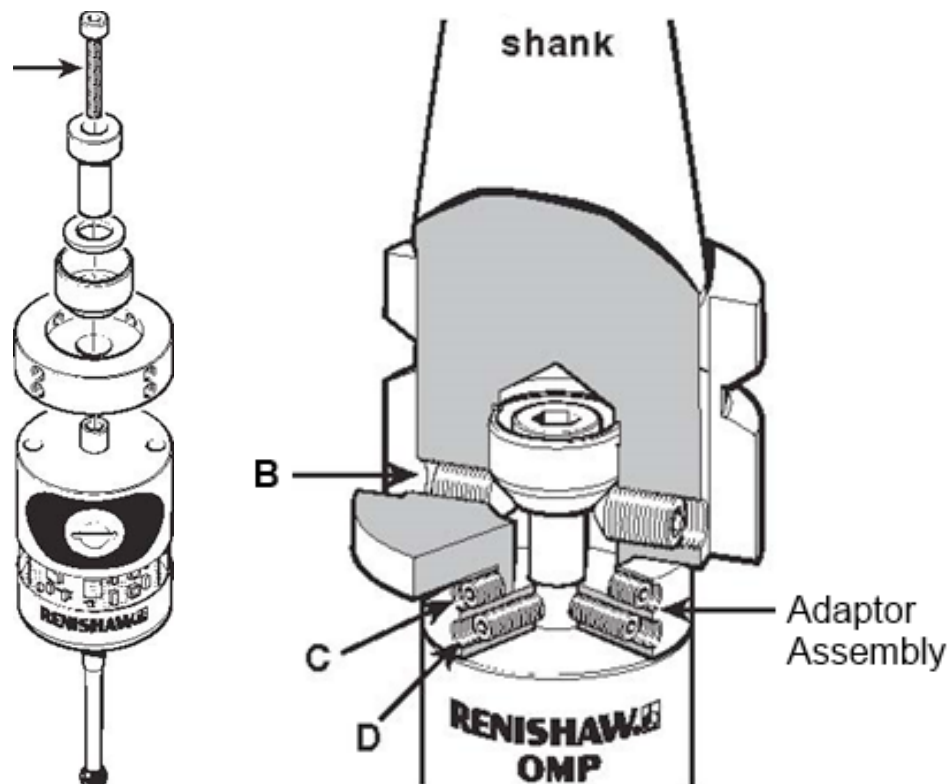

## Ballscrew Assemblies Reference

### Alignment Definitions for Angular Bearings and Belleville Washers

#### Bearing Alignment

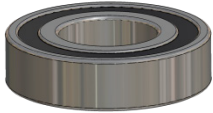

VIEW OPEN END UP

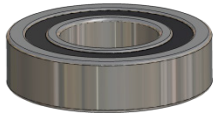

VIEW CLOSED END UP

#### Belleville Washer Alignment



VIEW CUP UP



VIEW CUP DOWN

### Z-Axis Lower Bearing and Belleville Washer Stacking Order

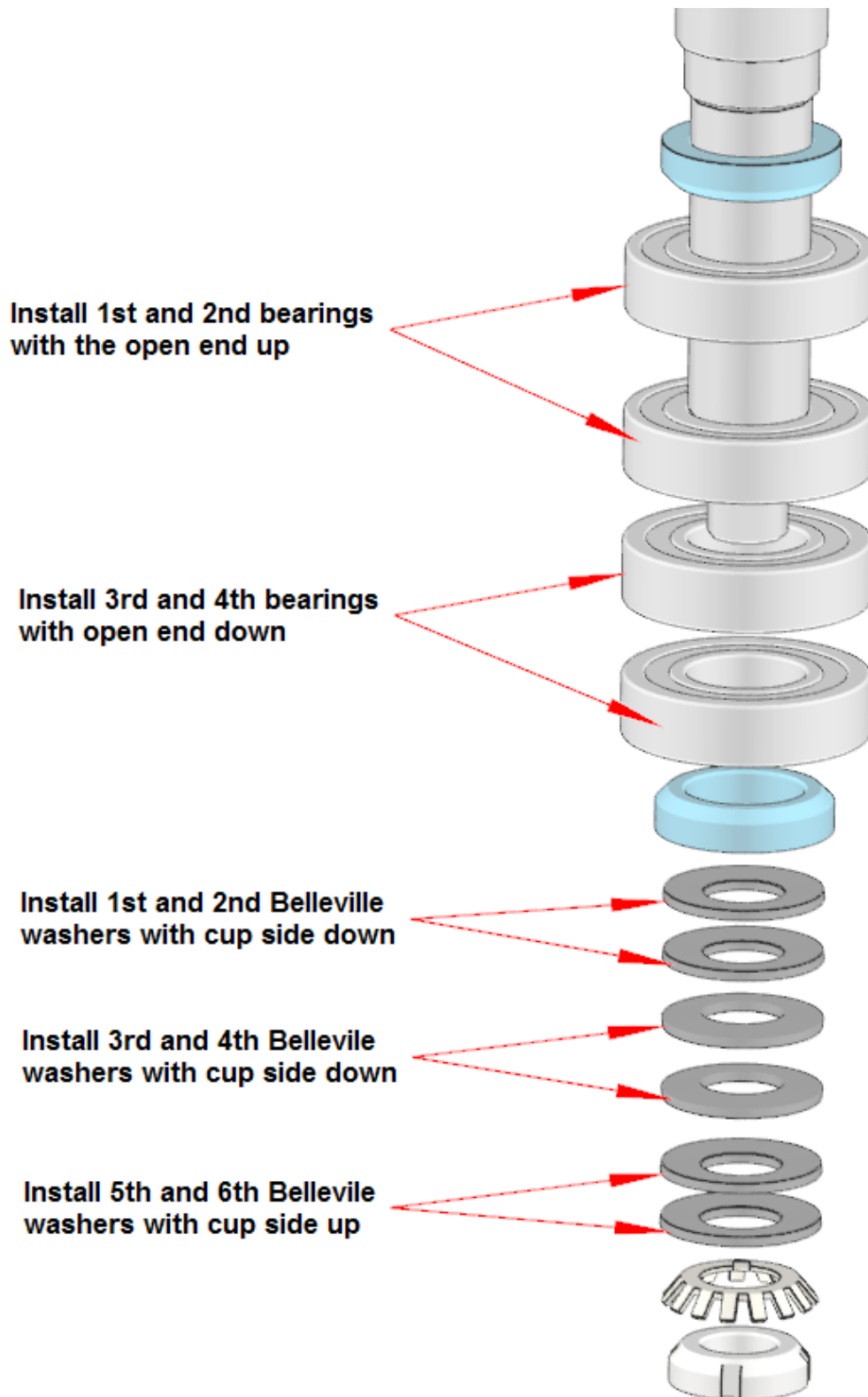

### Z-Axis Lower Bearing and Belleville Washer Section View

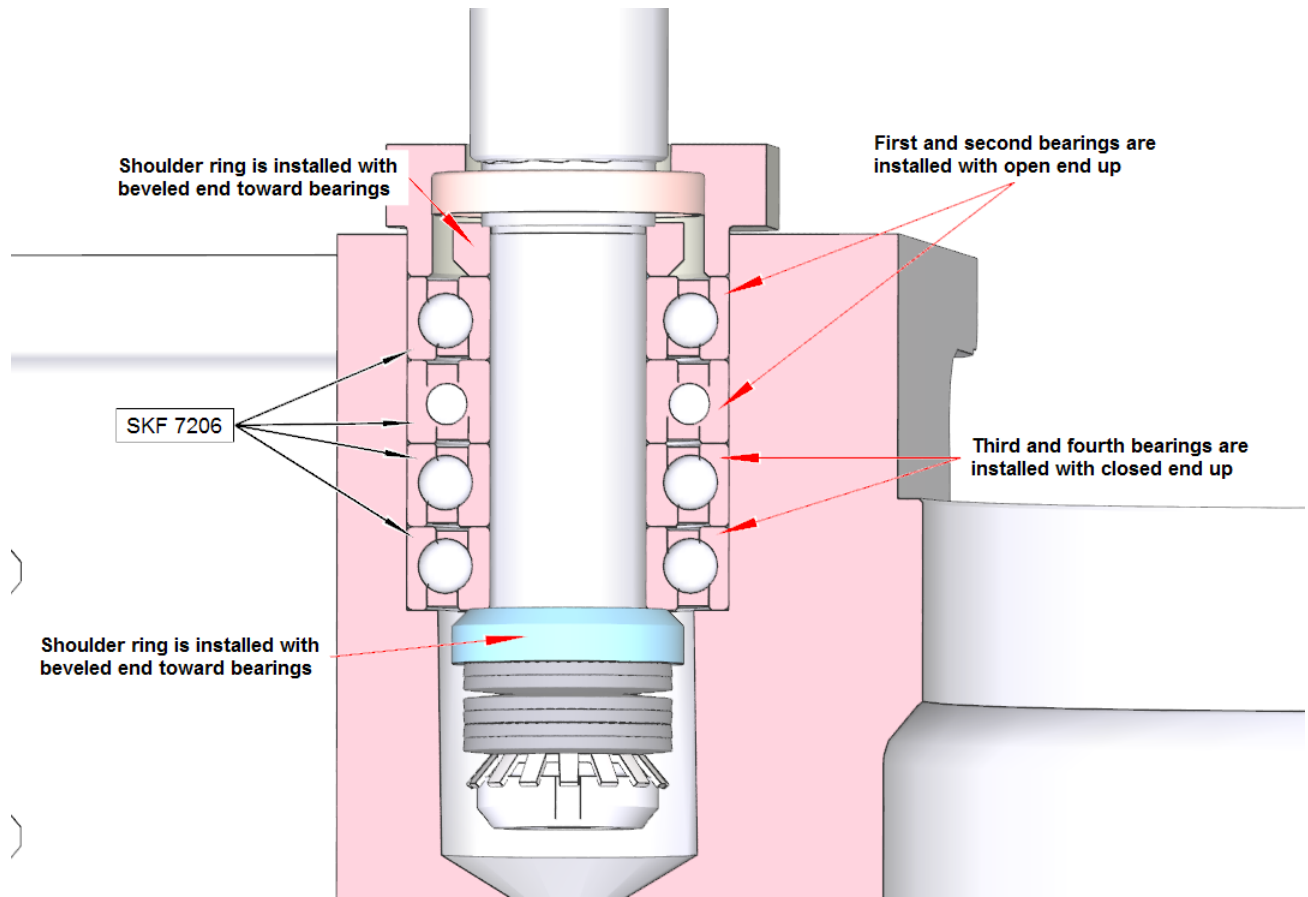

### Z-Axis Upper Belleville Washer Stacking Order

Install 1st washer with cup side facing out, then alternate next 3 washers.

### Z-Axis Upper Belleville Washer Section View

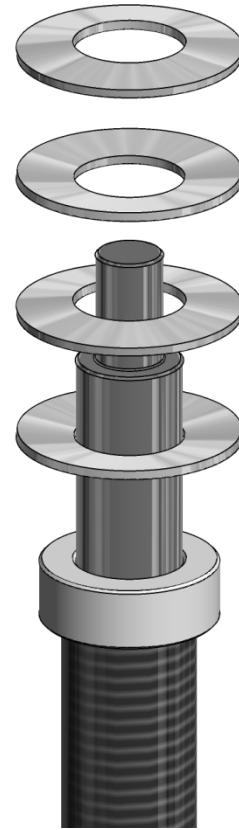
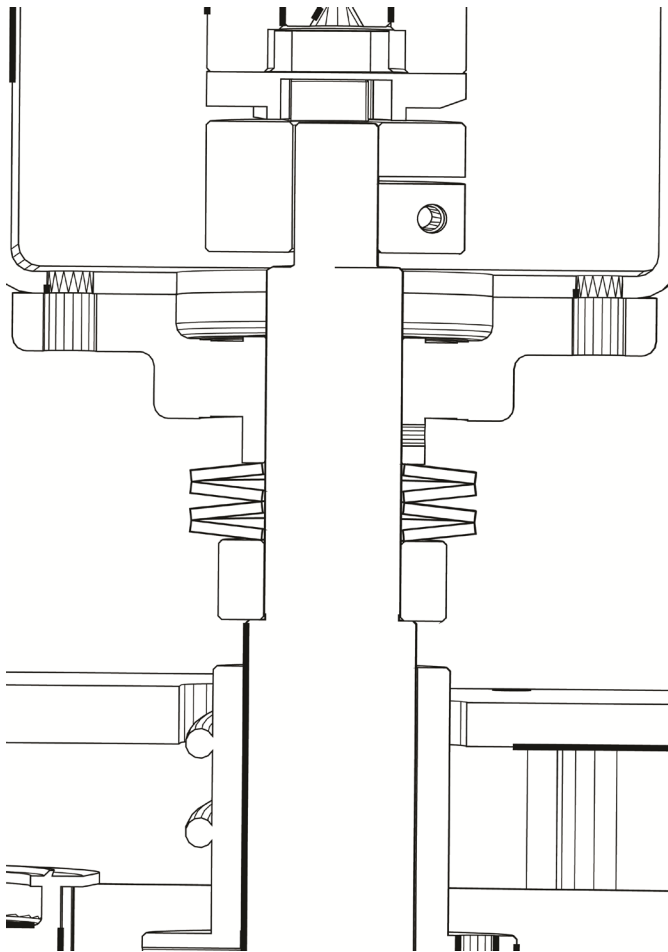

**X-Axis Drive Side Bearing Stacking Order**

Install both bearings with open side facing out.

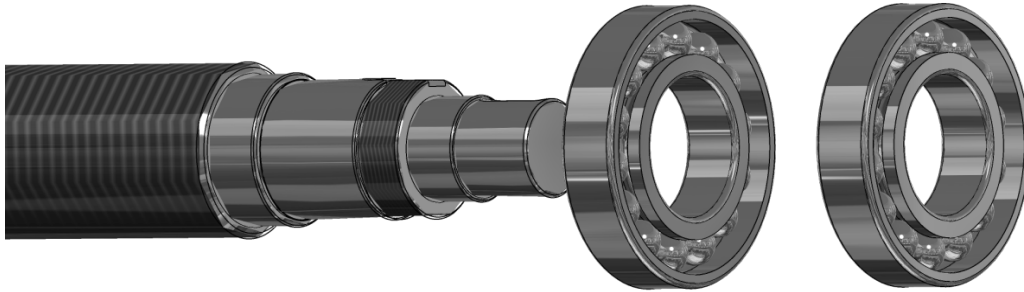
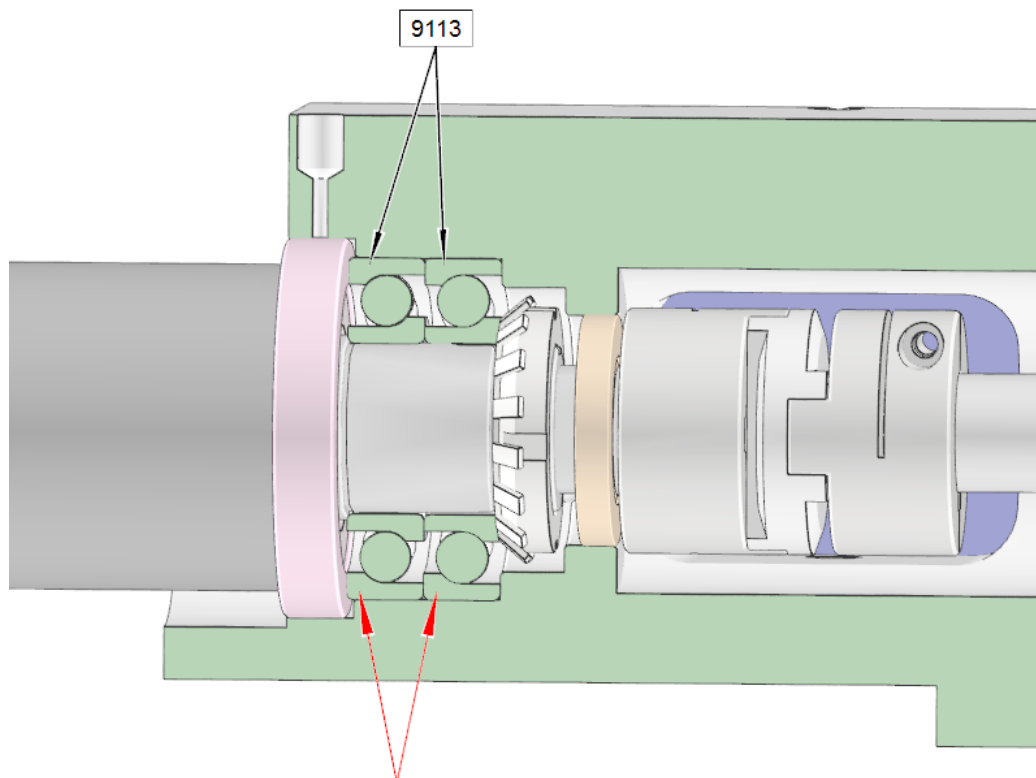
**X-Axis Drive Side Bearing Section View**

**Both bearings are installed  
with open end facing out**



### X-Axis Idle Side Bearing Stacking Order

Install both bearings with open side facing out.

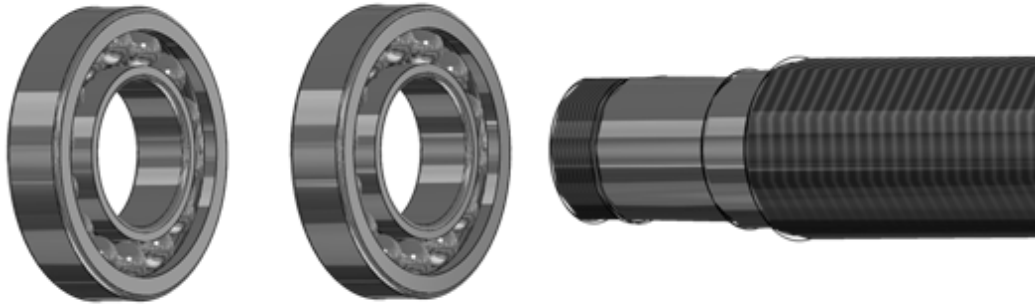

### X-Axis Idle Side Bearing Section View

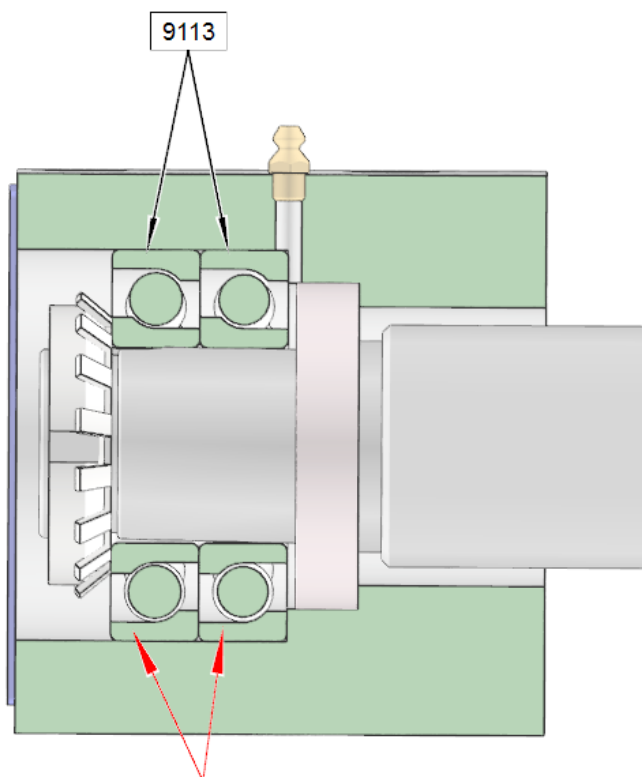

**Both bearings are installed  
with open end facing out**

### Y-Axis Bearing Stacking Order

Install 1st bearing with open end toward ballscrew shoulder. Install 2nd and 3rd bearings with closed end toward 1st bearing.

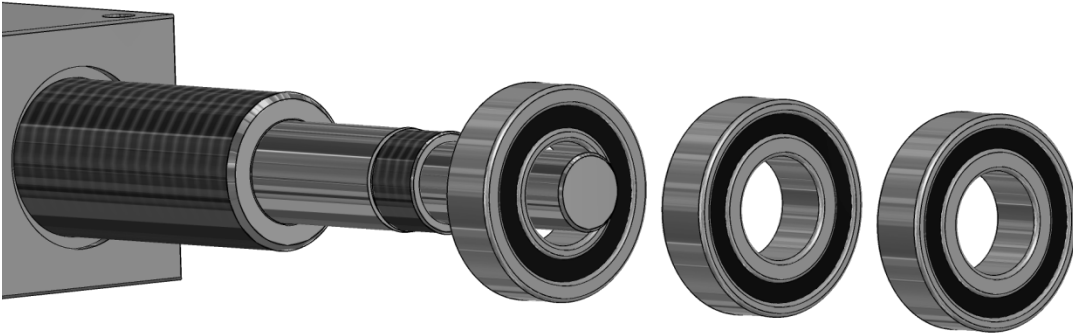

### Y-Axis Bearing Section View

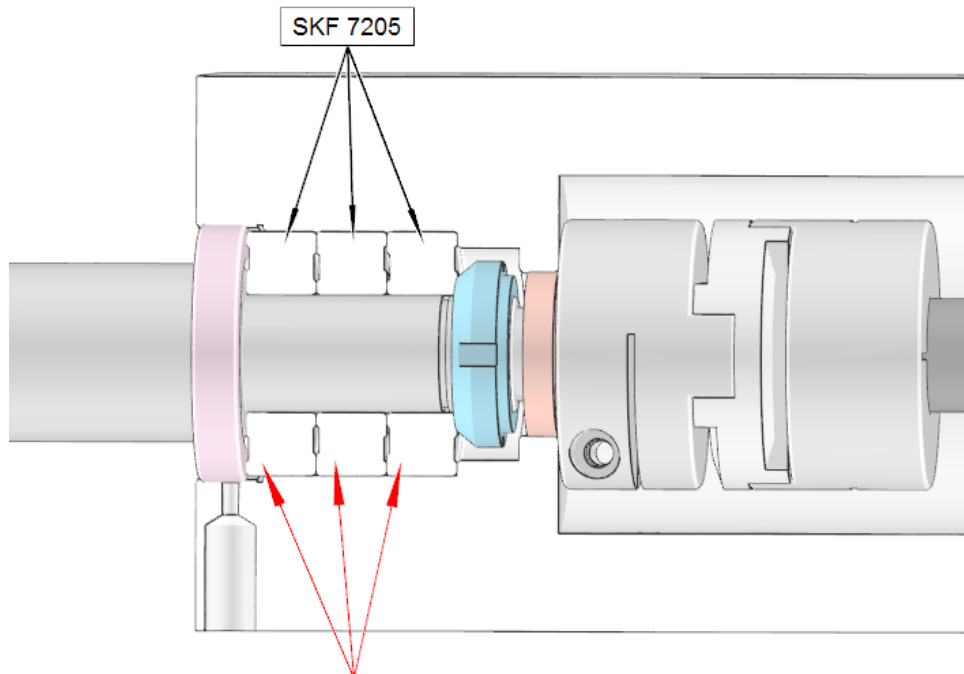

**All 3 bearings are installed  
with the open end facing out**

### Inner Spindle Upper Section Belleville Washer Stacking Order

6113 Belleville washers are stacked in an alternating pattern with the bottom washer installed cup face up. (see illustration on right side)

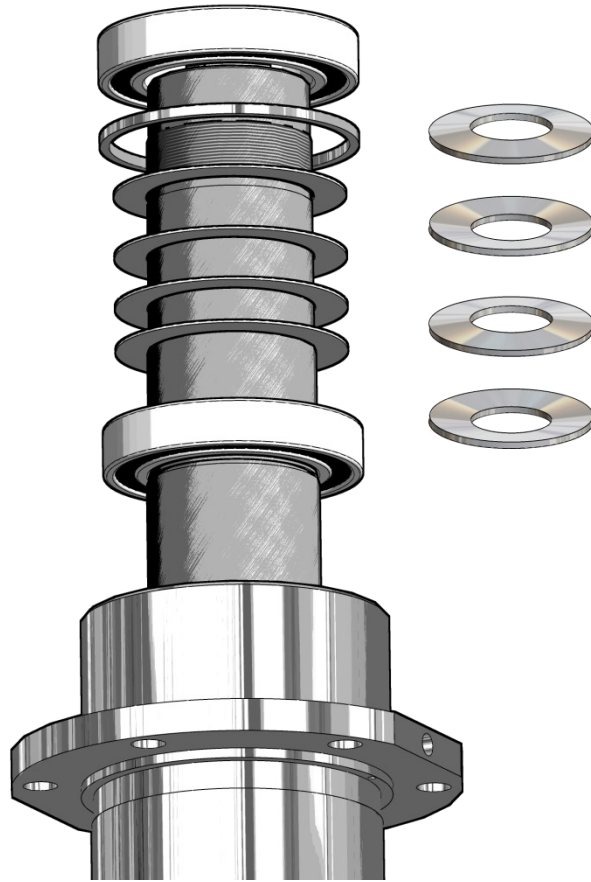

### Inner Spindle Upper Section Belleville Washer Section View

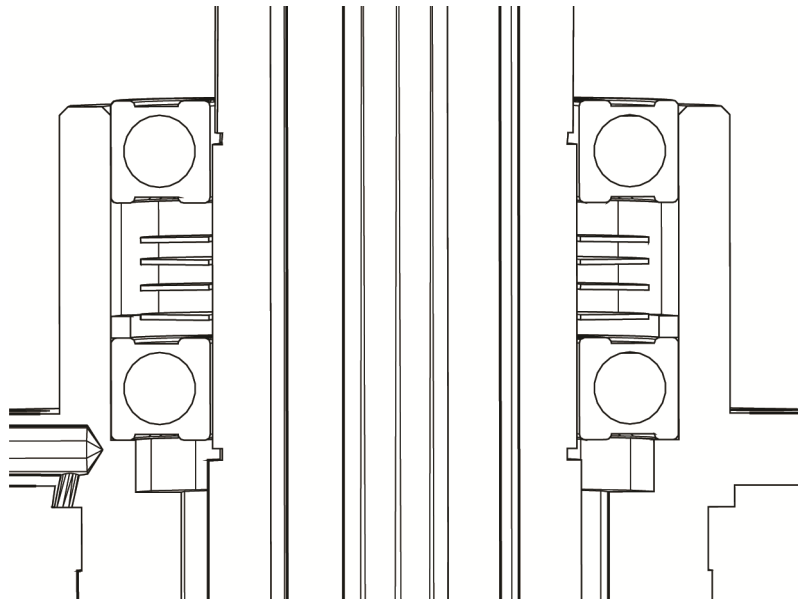

### Inner Spindle Lower Section Bearing Stacking Order

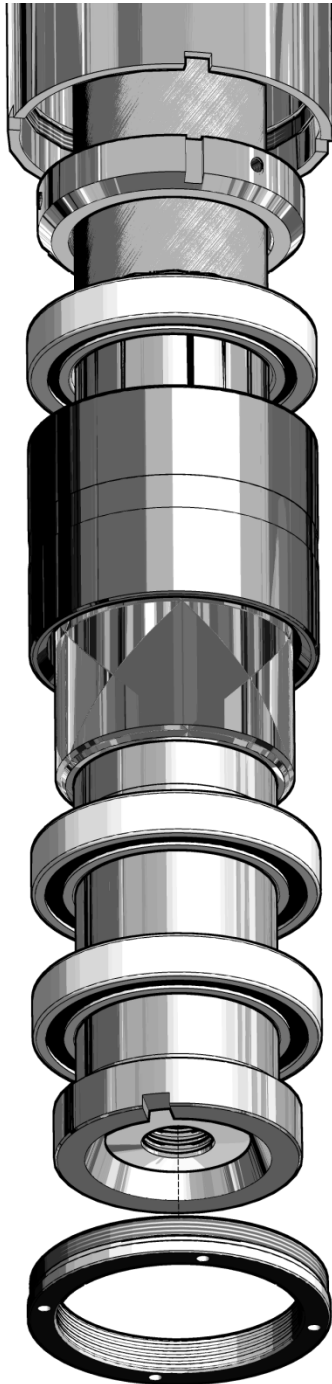

Install 3rd bearing with the closed side down.

Install inner and outer spacer assembly with beveled end facing up.

Install 2nd bearing with the open side down.

Install 1st bearing with the open side down.

### Inner Spindle Lower Section Bearing Section View

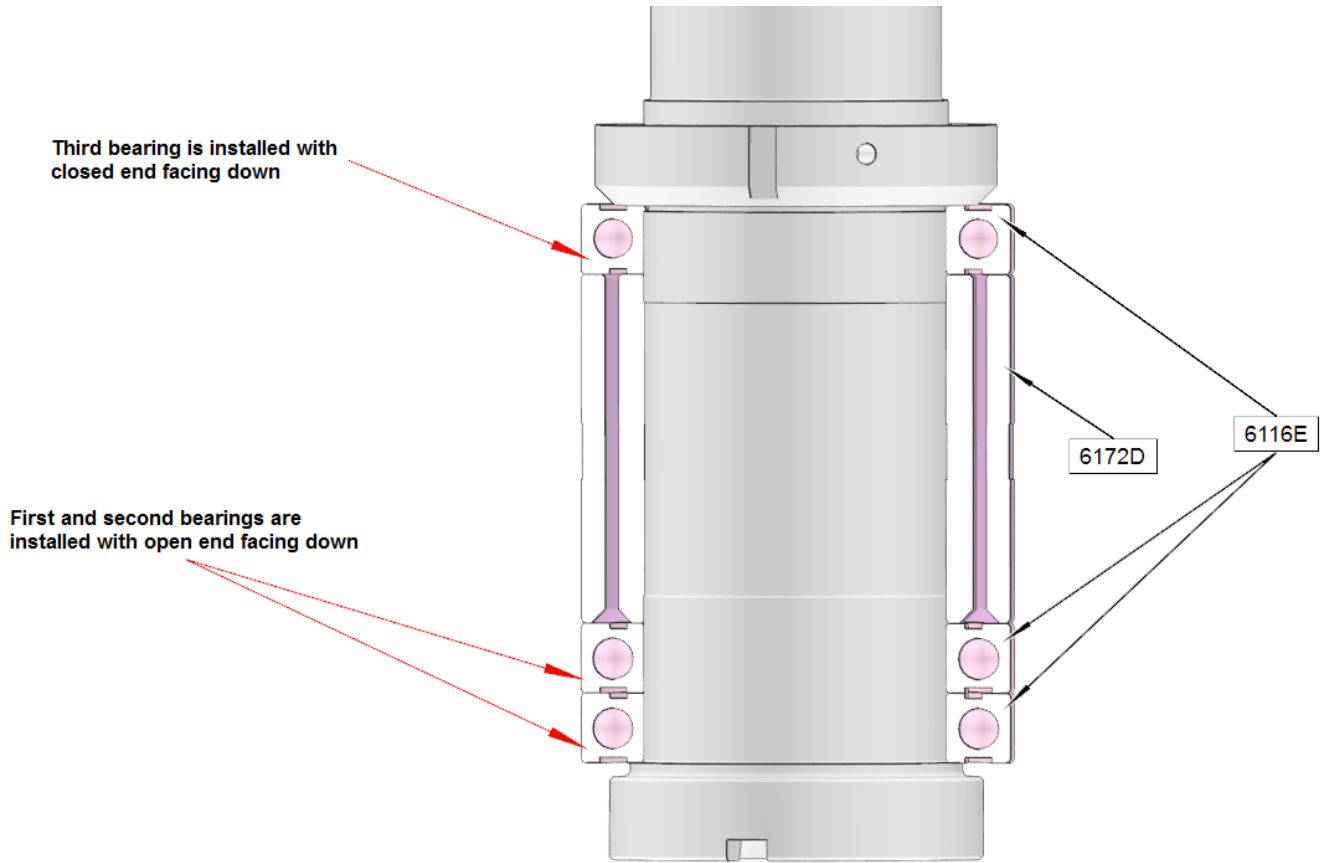

# **TROUBLESHOOTING**

**Please visit the service tab of our web page at Send a Service Request [www.rottlermfg.com](http://www.rottlermfg.com) or contact the Rottler Factory Service at [service@rottlermfg.com](mailto:service@rottlermfg.com) for assistance and your service request.**

**You may also call Rottler at 1-800-452-0534 or 1-253-872-7050**

**Please ensure you have the Machine Model and Serial Number available when contacting Rottler for Service**

This page intentionally left blank

# MACHINE PARTS

## Contents

<b>Rottler Replacement and Specialty Inserts.....</b>	<b>8-1</b>
<b>GENERAL INFORMATION .....</b>	<b>8-1</b>
Tool Nose Radius .....	8-1
Edge Preparation.....	8-1
Surfacing Inserts Cutting Speed Calculation .....	8-2
<b>CYLINDER BORING INSERTS .....</b>	<b>8-2</b>
RT321 (General purpose and sleeving) .....	8-2
RT322 (General purpose and sleeving) .....	8-3
RT211 (General purpose and sleeving) .....	8-3
RT212 (General purpose and sleeving) .....	8-3
RT321F (Precision Counterboring and Finishing).....	8-4
RT322F (Precision Counterboring and Finishing).....	8-4
RT211F (Precision Counterboring and Finishing).....	8-4
RT212F (Precision Counterboring and Finishing).....	8-4
RS322 (High speed oversize through boring).....	8-5
6301E (High speed oversize through boring) .....	8-5
501-29-6K (High speed aluminum boring).....	8-5
511-29-20E (Steel boring).....	8-5
<b>SURFACING INSERTS.....</b>	<b>8-6</b>
6303B .....	8-6
6303M.....	8-6
6303U .....	8-6
6303K.....	8-6
RS322.....	8-7
6301J.....	8-7



6303V .....	8-7
<b>1/2" (12.70mm) SURFACING INSERTS .....</b>	<b>8-7</b>
6303P .....	8-7
6303Q .....	8-7
6864E .....	8-7
<b>Bi-metal Surfacing .....</b>	<b>8-8</b>
<b>Cylinder Heads with Protruding Valve Seats .....</b>	<b>8-8</b>
6303S .....	8-8
6303U .....	8-8
6303R .....	8-8
6301V .....	8-9
<b>SPECIAL TOOLHOLDER AND INSERT FOR SURFACING .....</b>	<b>8-9</b>
<b>DIESEL ALUMINUM HEADS WITH STEEL PRE-CHAMBERS .....</b>	<b>8-9</b>
7202X .....	8-9
7202Z .....	8-9
<b>INSERTS FOR SHELL MILLING CUTTERHEADS .....</b>	<b>8-10</b>
6514T .....	8-10
<b>MAIN LINE BORING INSERTS .....</b>	<b>8-10</b>
<b>CONNECTING ROD INSERTS .....</b>	<b>8-10</b>
<b>Machine Parts .....</b>	<b>8-11</b>
Front Sheet Metal .....	8-11
Rear Left Sheet Metal .....	8-12
Right Rear Sheet Metal .....	8-13
Air Control Door .....	8-14
Air Control Solenoid Pack .....	8-15

<b>Oiler Door</b> .....	<b>8-16</b>
<b>Electrical Wiring Diagram</b> .....	<b>8-17</b>
<b>Electrical Enclosure Assembly F103/4/5M Series</b> .....	<b>8-18</b>
Enclosure Door .....	8-18
<b>Enclosure</b> .....	<b>8-19</b>
<b>Enclosure Panel</b> .....	<b>8-21</b>
<b>650-1-27X Computer Enclosure Assembly</b> .....	<b>8-23</b>
<b>650-7-1 Computer Components:</b> .....	<b>8-24</b>
<b>Spindle Base, Right Side</b> .....	<b>8-25</b>
<b>Spindle Base, Left Side</b> .....	<b>8-26</b>
<b>Motor Housing Parts</b> .....	<b>8-27</b>
<b>Z-Axis Motor Parts</b> .....	<b>8-28</b>
<b>Spindle Motor Housing Parts Outside</b> .....	<b>8-29</b>
<b>Spindle Motor Housing Parts Inside</b> .....	<b>8-30</b>
<b>Upper Spindle &amp; Ballscrew Parts</b> .....	<b>8-31</b>
<b>Lower Spindle &amp; Ballscrew Parts</b> .....	<b>8-33</b>
<b>Inner Spindle Lower Section Parts</b> .....	<b>8-35</b>
<b>Y-Axis Drive Parts</b> .....	<b>8-36</b>
<b>Column Slide Parts</b> .....	<b>8-38</b>
<b>Pendant Swing Arm</b> .....	<b>8-39</b>
Pendent Swing Arm Assembly Parts List .....	8-40
<b>Pendant Assembly</b> .....	<b>8-41</b>
<b>Main Base Parts</b> .....	<b>8-42</b>
<b>X-Axis Assembly: Drive End</b> .....	<b>8-43</b>
<b>X-Axis Assembly: Idle End</b> .....	<b>8-44</b>
<b>Chip Shield Assembly</b> .....	<b>8-45</b>
<b>Front Cover and Lights</b> .....	<b>8-46</b>
<b>Oil Line Diagram</b> .....	<b>8-47</b>

## Rottler Replacement and Specialty Inserts

Below is a description of the cutting inserts available from Rottler. The inserts have gone through extensive performance testing. To take full advantage of the capabilities of your Rottler machine, we highly recommend Rottler cutting tools be used. Rottler machine performance can be significantly reduced if qualified tooling is not used. Using an incorrect insert can result in bore geometry inconsistency, short tool life, and poor surface finish.

Below are general guidelines. When using these inserts it is best to refer to the operator manual of the particular machine you are using. Rottler Manufacturing's latest operator manuals have more detailed information on feeds and speeds for the particular machine and cutterhead that you are using.

### GENERAL INFORMATION

Rottler CBN and PCD Inserts are laser marked with our part number on one side. On single sided inserts, the part number is on the back side of the insert.

Rottler surfacing insert toolholders are designed so they can hold square and round inserts that are of the same basic size. For example, a 3/8" (9.52 mm) IC round and 3/8" (9.52 mm) IC square insert will fit into the standard 3/8" (9.52 mm) IC Rottler toolholders. IC refers to inscribed circle.

Rottler SF, F60, F80 and F90 Series surfacing cutterheads are supplied standard with Rottler 3/8" (9.52 mm) IC toolholders fitted to our surfacing heads. Optional 1/2" (12.7 mm) toolholders are interchangeable with 3/8" (9.52 mm) toolholders.

Insert breaking or chipping can be caused by several things. It can be caused by not operating the insert at the correct RPM. It is very typical for an insert to break or chip when cutting too slow. Interrupted cuts can cause an insert to break as well. When making a heavy sleeve cut in a cylinder that has been cracked it is often required to slow the RPM down to 1/2 the normal operating speed to prevent chipping of the insert.

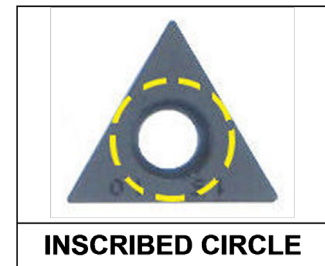

### Tool Nose Radius

The tool nose radius has an important effect on the cutting process. If you use the same feed rate per revolution on two different sized tool nose radius the larger tool radius will give a smoother finish. There are two other important characteristics of the tool radius. The larger the tool radius the stronger the cutting edge. The larger radius will hold up to interrupted cuts better than a smaller radius.

A disadvantage of a larger tool radius is that it creates more tool pressure than a smaller radius. When using long small diameter boring bars or large diameter milling cutterheads the high tool pressure of a large radius can cause chatter in the finish.

### Edge Preparation

Rottler inserts have edge preparations specifically designed for proper cutting performance. Some inserts have sharp edges, some have a few ten thousandths of an inch honed edge. Others have a T land which is actually a beveled edge. Generally the sharp edge will require the minimum amount of cutting pressure but the edge will not be as strong and long lasting. The T land insert is at the opposite end of the spectrum. It generates a lot of cutting force and can create chatter. The advantage of a T land is that it is very tough. Most Rottler inserts have a honed edge which gives a good balance between cutting performance and tool life.

## Surfacing Inserts Cutting Speed Calculation

Inserts are designed to cut within a speed range – S.F.P.M. In order to convert from cutting speed to RPM, use the following formula:

$$\text{RPM} = \frac{\text{S.F.P.M.} \times 3.82}{\text{DIAMETER}}$$

S.F.P.M. = Surface Feet per Minute

RPM = Revolutions per Minute

DIAMETER in Inches

The feed rate on most Rottler machines is designated in inches / revolution. Rottler machines have feed rates designated in inches / minute. It is important to adjust the inches / minute rate to obtain the correct load (inches / revolution). Following are the formulas to use. You do not have to perform this calculation with an “A” model machine

If you know the RPM and the Feed Rate per Revolution you want, use the following formula to obtain the correct Feed Rate per minute.

$$\text{FRM} = \text{RPM} \times \text{FRR}$$

FRM = Feed Rate Inches per Minute

FRR = Feed Rate Inches per Revolution

RPM = Spindle Revolutions per Minute

### METRIC CONVERSIONS

1 inch = 25.4 mm = 2.54 cm = .0254 meters

1 mm = .040 inches

## CYLINDER BORING INSERTS

Rottler has just completed the development of group of new triangular inserts for cylinder boring. Extensive trials were made to come up with new inserts that would outperform the older inserts. The result is a group of inserts that are the same unit cost but have 5 – 50% increased tool life. The increased tool life decreases overall operation cost to the end user.

Rottler offers either triangular or square inserts for cylinder boring, sleeving, and counter boring. Triangular inserts are excellent general purpose inserts for doing all boring, sleeving and counterboring operations. When doing counter boring operations it is important to use a tool nose radius small enough that it will not interfere with the mating corner on the part that is installed in the counterbore.

When removing less than .060” (1.50mm) on the diameter a square insert is the most economical insert to use. The square inserts Rottler offers have 8 cutting edges. A Triangular insert only has 3 cutting edges.

### RT321 (General purpose and sleeving)

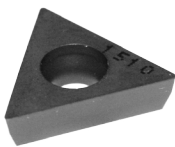

A 3/8” (9.52 mm) IC triangular insert with a black ceramic coating and 1/64” (.4 mm) cutting radius. This insert is the best to use for counterboring when the small corner radius is required for clearance or when the machine is at its extended travel limits. The 1/64” (.4 mm) radius should be used when machining to a step where the mating part requires a smaller radius to eliminate an interference problem in the radius. If you are machining a long bore where the spindle must be extended towards the limits

of its travel or if a long stub bar is being used, the 1/64” (.4 mm) radius will minimize the possibility of chatter. A feed rate of .002” - .005” (.05 mm - .12 mm) per revolution should be used to obtain a typical surface finish. When machining large counter bores typically found in Cummins or Cat Blocks, a feed rate of .002” - .004”/rev (.02 mm-.1 mm/rev) should be used. When cutting gray cast iron use a speed in the 800 – 1200 S.F.P.M. area for best productivity and tool life.

When cutting nodular, ductile, or compacted graphite cast iron the speed should be in the 200 – 400 S.F.P.M. area – 300 RPM on a 4" (100 mm) diameter bore. Nodular, ductile, or compacted graphite cast irons, is found most often in high performance engine blocks or sleeves. When cutting these tuff cast irons it is best to use a feed rate of between .002 and .005 (.05 mm and .13 mm) per revolution.

### RT322 (General purpose and sleeving)

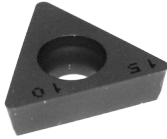

This is the same insert as RT321, except it has a 1/32" (.8 mm) radius. This insert is the best to use for heavy sleeve cutting and can also be used for general machining and counterboring. This larger radius insert will give a smoother finish for a given feed rate when sleeve cutting to allow easier sleeve fitting and closer metal to metal contact for heat transfer. It is possible to use a feed rate that is 30% faster with the RT322 compared with the RT321 and still obtain the same finish. The 1/32" (.8 mm) radius is stronger than the 1/64 (.4mm) radius of the RT321. The RT322 should always be used for heavy sleeve cuts unless the finish part requires the smaller radius for clearance or you are cutting a long bore. The larger radius creates more tool pressure than the small radius. The increased tool pressure may cause chatter in the finish if machining very long bores. A feed rate of .006" - .012" (.15 mm - .3 mm) per revolution should be used to obtain a typical surface finish. When machining large counter bores typically found in Cummins or Cat Blocks, a feed rate of .002" - .004"/rev (.05 mm-.1 mm/rev) should be used. When cutting gray cast iron use a speed in the 800 – 1200 S.F.P.M. area for best productivity and tool life.

When cutting nodular, ductile, or compacted graphite cast iron the speed should be in the 200 – 400 S.F.P.M. area – 300 RPM on a 4" (100 mm) diameter bore. Nodular, ductile, or compacted graphite cast irons, is found most often in high performance engine blocks or sleeves. When cutting these tuff cast irons it is best to use a feed rate of between .006" and .010" (.15 mm and .25 mm) per revolution.

### RT211 (General purpose and sleeving)



A 1/4" (6.35 mm) IC triangular insert with a black ceramic coating and 1/64" (.4 mm) cutting radius. The 1/64" (.4 mm) radius should be used when machining to a step where the mating part requires a smaller radius to eliminate an interference problem. If you are machining a long bore where the spindle must be extended towards the limits of its travel or if a long stub bar is being used, the 1/64" (.4 mm) radius will minimize the possibility of chatter. A feed rate of .002" - .005" (.05 mm - .12 mm) should be used to obtain a typical surface finish. When machining large counter bores typically found in Cummins or Cat Blocks, a feed rate of .002" - .004"/rev (.05 mm - .1 mm/rev) should be used. When cutting gray cast iron use a speed in the 800 – 1200 S.F.P.M. area for best productivity and tool life.

When cutting nodular, ductile, or compacted graphite cast iron the speed should be in the 200 – 400 S.F.P.M. area – 300 RPM on a 4" (100 mm) diameter bore. Nodular, ductile, or compacted graphite cast irons, is found most often in high performance engine blocks or sleeves. When cutting these tuff cast irons it is best to use a feed rate of between .002 and .005 (.05 mm and .13 mm) per revolution.

### RT212 (General purpose and sleeving)



This is the same insert as RT212, except it has a 1/32" (1.6 mm) radius. This larger radius insert will give a smoother finish when sleeve cutting to allow easier sleeve fitting and closer metal to metal contact for heat transfer. The 1/32" (1.6 mm) radius is stronger than the 1/64 (.8 mm) radius of the RT321. The RT322 should always be used for sleeve cuts unless the finish part requires the smaller radius for clearance or you are cutting a long bore. The larger radius creates more tool pressure than the small tool radius. The increased tool pressure will create chatter in the finish. A feed rate of .006" - .012" (.15 mm - .3 mm) per revolution should be used to obtain a typical surface finish. When machining large counter bores typically found in Cummins or Cat Blocks, a feed rate of .002" - .004"/rev (.05 mm - .1 mm/rev) should be used. When cutting gray cast iron use a speed in the 800 – 1200 S.F.P.M. area for best productivity and tool life.

When cutting nodular, ductile, or compacted graphite cast iron the speed should be in the 200 – 400 S.F.P.M. area – 300 RPM on a 4" (100 mm) diameter bore. Nodular, ductile, or compacted graphite cast iron is found most often in high performance engine blocks or sleeves. When cutting these tuff cast irons it is best to use a feed rate of between .006" and .010" (.15 mm and .25 mm) per revolution.

### RT321F (Precision Counterboring and Finishing)



A 3/8" (9.52 mm) IC triangular, uncoated insert with a 1/64" (.8 mm) cutting radius. Gives the best finish results when machining precision counter bores often machined in diesel engine blocks. The 1/64" (.8 mm) radius should be used when machining to a step where the mating part requires a smaller radius to eliminate an interference problem. If you are machining a long bore where the spindle must be extended towards the limits of its travel or if a long stub bar is being used, the 1/64" (.8 mm) radius will minimize the possibility of chatter. A feed rate of .002" - .005" (.05 mm - .12 mm) should be used to obtain a typical surface finish. When machining large counter bores typically found in Cummins or Cat Blocks, a feed rate of .002 - .004/rev. (.05 mm - .1 mm/rev) should be used.

### RT322F (Precision Counterboring and Finishing)



A 3/8" (9.52 mm) IC triangular, uncoated insert with a 1/32" (1.6 mm) cutting radius. Gives the best finish results when machining precision counter bores often machined in diesel engine blocks. A feed rate of .004" - .008" (.05 mm - .1 mm) should be used to obtain a typical surface finish. When machining large counter bores typically found in Cummins or Cat Blocks, a feed rate of .002 - .004/rev. (.05 mm - .1 mm/rev) should be used. When cutting gray cast iron use a speed in the 300 - 600 S.F.P.M. area for best productivity and tool life. Tool life of this insert is significantly less than the RT322.

### RT211F (Precision Counterboring and Finishing)

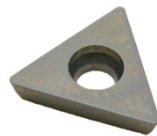

A 1/4" (6.35 mm) IC triangular, uncoated insert with a 1/64" (.8 mm) cutting radius. Gives the best finish results when machining precision counter bores often machined in diesel engine blocks. The 1/64" (.8 mm) radius should be used when machining to a step where the mating part requires a smaller radius to eliminate an interference problem. If you are machining a long bore where the spindle must be extended towards the limits of its travel or if a long stub bar is being used, the 1/64" (.8 mm) radius will minimize the possibility of chatter. A feed rate of .002 - .005 (.05 mm - .12 mm) should be used to obtain a typical surface finish. When machining large counter bores typically found in Cummins or Cat Blocks, a feed rate of .002 - .004/rev. (.05 mm - .1 mm) should be used. When cutting gray cast iron use a speed in the 300 - 600 S.F.P.M. area for best productivity and tool life. Tool life of this insert is significantly less than the RT211

### RT212F (Precision Counterboring and Finishing)



A 1/4" (6.35 mm) IC triangular insert with a gold coating and 1/32" (1.6 mm) cutting radius. The coating gives the best finish results when machining precision counter bores often machined in diesel engine blocks. A feed rate of .002 - .005 (.05 mm - .12 mm) should be used to obtain a typical surface finish. When machining large counter bores typically found in Cummins or Cat Blocks, a feed rate of .002 - .004/rev. (.05 mm - .1 mm/rev.) should be used. When cutting gray cast iron use a speed in the 300 - 800 S.F.P.M. area for best productivity and tool life. Tool life of this insert is significantly less than the RT211.



**RS322 (High speed oversize through boring)**

A 3/8" (9.52 mm) IC, square insert with a black ceramic coating. It is used on Rottler boring machines for through boring when removing .010" - .060" (.25 mm - 1.5 mm) on the diameter. A very economical insert as it has 8 cutting edges. On a 4" (100mm) bore use 1000 - 1200 RPM and a feed rate of .008" - .012" (.2 mm - .3 mm) per rev feed rate to obtain the typical surface finish. The insert can also be used for sleeve cuts when a square step is not required. For example, when used on an F80 or F5 machine it can be run at 1000 – 1200 RPM and .005/rev (.12 mm/rev) feed rate to remove up to .200" (5 mm) on the diameter from a 4.200" (106 mm) bore.

When cutting nodular, ductile, or compacted graphite cast iron the speed should be in the 200 – 400 S.F.P.M. area – 300 RPM on a 4" (100 mm) diameter bore. Nodular, ductile, or compacted graphite cast iron is found most often in high performance engine blocks or sleeves. When cutting these tuff cast irons it is best to use a feed rate of between .006" and .010" (.15 mm and .25 mm) per revolution.

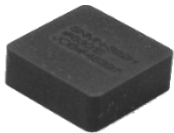
**6301E (High speed oversize through boring)**

This is a square 3/8" (9.52 mm) IC, 1/32" (1.6 mm) radius, double sided, CBN Insert. These inserts are intended for use on high speed boring on Rottler F80 and F60 series machines. On common cast iron blocks the RPM should be set to achieve 1000 – 2200 S.F.P.M. On harder cast irons the RPM should be reduced to obtain acceptable tool life. A feed rate of .010" - .014" (.25 mm - .36 mm) per revolution. They have exceptional long life when removing up to .040" (1.02 mm) on the diameter. They do not give good tool life on some cast irons with high sulfur content.

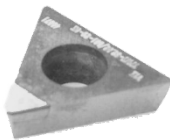
**501-29-6K (High speed aluminum boring)**

This is a 3/8" (9.52 mm) IC, triangle insert with a black diamond tip. It has a 1/32" (1.6 mm) radius. This insert is used to bore aluminum cylinders. It cannot be used to bore any other material. It is the best insert for finishing aluminum. For best tool life and finish the insert can be run from 400 – 4000 SFM. Feed rates between .004" and .010" (.1 mm and .25 mm) should be used.

**511-29-20E (Steel boring)**

A 3/8" (9.52 mm) IC triangular insert with a gold coating and 1/32" (1.6 mm) cutting radius. This insert is for boring steel and ductile iron. It features a chip breaker to break-up the "string" of metal that can often form when boring steel.

## SURFACING INSERTS

Rottler offers a wide variety of inserts used for surfacing. There are many applications in surfacing that include a variety of materials to be surfaced. Cylinder heads with pre-combustion chambers are particularly challenging because there are such a variety of materials used by the different cylinder head manufactures. One of the latest inserts we have tested for cutting cylinder heads with pre-combustion chambers is the 7202Z. It is probably the best for cutting a wide variety of heads with pre-combustion chambers. The 6303B is our standard for cutting a wide variety of cast iron heads. The 6303B will cut aluminum but is not ideal. The best insert for cutting aluminum is the 6303M which is a diamond insert.

When machining large cylinder blocks with larger precision depth counter bores using a 18" (450mm) or larger diameter fly cutter it is important to use a square 6301J insert. The smaller radius minimizes cutter deflection and will result in more accurate counterbore depths.

Below are the inserts commonly used on Rottler machines in surfacing/milling applications. Please read carefully..

### 6303B



A round 3/8" (9.52 mm) IC, double sided, CBN Insert. An excellent, long life insert for surfacing cast iron heads and blocks - round shape gives many cutting edges on each side of insert. When using a 14" (355.6 mm) cutterhead (SF, F65, F80) speeds range from 900-1200 RPM. When using an 18" (457 mm) cutterhead speeds range from 600-800 RPM.

### 6303M



A round 3/8" (9.52 mm) IC, single sided, PCD Insert. For use on aluminum only - heads and blocks without liners. This insert has a thin layer of PCD applied to a carbide disk. The diamond appears to be a shiny black wafer. The hardness of the diamond resists the abrasive nature of the silica in aluminum heads and blocks. RPM speeds with a 14" (355.6 mm) cutter range from 900-2000 RPM.

### 6303U



A round 3/8" (9.52 mm) IC, single sided, CBN Insert. This insert does an excellent job when cutting hard cast iron blocks and heads of a single material or bi-metal. This insert is the best to use when machining compacted graphite cast iron heads and blocks often found in the performance industry. RPM speeds with a 14" (355.6 mm) cutter range from 650-750 RPM.

### 6303K



A round, gold-colored, 3/8" (9.52 mm) IC, single sided, coated carbide insert. This is a very economical, general purpose insert for surfacing aluminum. It is advisable to use this insert for rough cutting to remove welding or contaminants before. A PCD insert should be used for the final cut to give the super fine finish required for MLS (multi layer steel) head gaskets. RPM speeds with a 14" (355.6 mm) cutterhead range from 600-1000 RPM.



**RS322**

A square 3/8" (9.52 mm) IC carbide insert with a very dark purple ceramic coating. This carbide insert is normally used for high speed boring. It works well as an economical insert for rough surfacing or heavy stock removal of cast iron. A CBN insert should be used for the final finish cut.

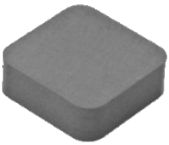
**6301J**

A square 3/8" (9.52 mm) IC, 1/16" (.0039 mm) radius, double sided, CBN Insert. The 1/16" (.0039 mm) radius of this insert will produce a more accurate (flatter) finish than a round insert typically used for surfacing on F80/F90 Series machines when surfacing large diesel blocks and heads which are high in nickel. The square surfacing insert is intended for F80/F90 applications where it may encounter heavier cuts and greater interrupted cuts. When using an 18" (457 mm) cutter speeds range from 600-800 RPM, and with a 14" (355.6 mm) cutter speeds range from 900-1200 RPM.

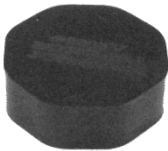
**6303V**

An octagonal 3/8" (9.52 mm) IC, .094" (2.4 mm) corner radius, double sided, solid CBN Insert with 16 cutting corners. The .094" (2.4mm) corner radius of this insert will produce a more accurate (flatter) finish than a round 3/8" (.52mm) or square 1/16" (1.6mm) corner radius insert typically used for surfacing on F70/F80/F90/F100 Series machines when surfacing large diesel blocks and heads which are high in nickel. The octagonal surfacing insert is intended for applications where it may encounter interrupted cuts. When using an 18" (457 mm) cutterhead, speeds range from 600-800 RPM, and with a 14" (355.6 mm) cutter speeds range from 900-1200 RPM. The .094" (2.4mm) corner radius will allow faster feed rates compared to the 6301J square insert.

**1/2" (12.70mm) SURFACING INSERTS****6303P**

A round 1/2" (12.7 mm) IC, single sided, PCD Insert. For use on aluminum only - heads and blocks without liners. This insert has a thin layer of PCD applied to the top of a carbide disk. The diamond appears to be a shiny black wafer. The hardness of the diamond resists the abrasive nature of the silica in aluminum heads and blocks. RPM speeds with a 14" (355.6 mm) cutter range from 1000-2000 RPM. Requires the purchase of 1/2" (12.7 mm) negative rake tool holders. The standard Rottler 3/8" (9.52 mm) IC tool holders will not hold this insert.

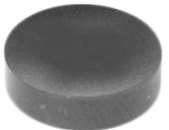
**6303Q**

A round 1/2" (12.7 mm) IC double sided, CBN Insert. An excellent insert for machining cast iron heads and blocks. Round shape gives many cutting edges on each side of insert. Requires the purchase of 1/2" (12.7 mm) negative rake tool holders. The standard Rottler 3/8" (9.52 mm) IC tool holders will not hold this insert.

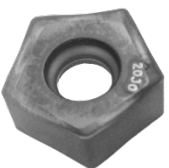
**6864E**

A five sided / five cornered insert coated carbide insert. There are a total of ten cutting corners on this inserts. This is the best insert for roughing and finishing spray weld. This is used in Rottler milling heads that are designed specifically for cutting spray weld. Currently they cannot be used in Rottlers common "flycutter" style surfacing cutterheads.

## Bi-metal Surfacing

### Cylinder Heads with Pre-combustion Chambers and Aluminum Blocks with Hard Sleeves

Cylinder heads with pre-combustion chambers or aluminum engine blocks with cast iron or steel cylinder sleeves are a challenge to cut and most often require a special cutting insert and special cutting technique. There are many different material combinations so there is not one insert that works the best on all applications. Below is information to use as a guide to the best insert to use and some of the required cutting parameters.

Generally the tool life when using any of these inserts in the cutting of bi-metal surfaces will be short when compared to cutting a single material. The cost of the insert per surfacing job will be higher compared with cutting single materials. The customer must incorporate the higher insert cost into the price charged for the surfacing job.

Another excellent alternative to cutting cylinder heads with pre-combustion chambers is to remove the combustion chamber from the head, surface the cylinder head, then use the Rottler Pre-combustion Chamber Re-seating Tool to machine the combustion chamber counterbore back to OEM specification depth. It is fast and economical to use. See Bulletin C49.

## Cylinder Heads with Protruding Valve Seats

Some cylinder heads have valve seats that protrude into the head gasket surface. Valve seats are made out of a wide variety of material. Some are very hard or difficult to cut when compared with the aluminum or cast iron head surface. In many cases it is best to cut the valve seat down below the head surface in a seat and guide machine. This takes a few more minutes when cutting the valve seats but it can save a lot of time and minimize tooling cost when surfacing the head.

The following inserts use Rottler 3/8" (9.52mm) Toolholders supplied with Rottler Surfacing Cutterheads;

### 6303S



A round 3/8" (9.52 mm) IC, single sided, CBN Insert. For use on aluminum blocks with iron liners and aluminum heads with steel pre-combustion chambers. RPM speeds with a 14" (355.6 mm) cutter range from 650-750 RPM.

### 6303U



A round 3/8" (9.52 mm) IC, single sided, CBN Insert. This insert does an excellent job when cutting hard cast iron blocks and heads of a single material or bi-metal. This insert is the best to use when machining compacted graphite cast iron heads and blocks often found in the performance industry. RPM speeds with a 14" (355.6 mm) cutter range from 650-750 RPM.

### 6303R



A round 3/8" (9.52 mm) IC, single sided, CBN Insert. For use on cast iron heads with steel pre-combustion chambers. RPM speed with a 14" (355.6 mm) cutter range from 600-700 RPM and with an 18" (457 mm) cutter range from 500-600 RPM.

63011

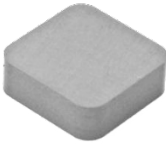

A square 3/8" (9.52 mm) IC, double sided, ceramic insert. For use on cast iron heads with pre-combustion chambers. You can make one finish cut and two rough cuts with each new cutting edge. Always use a new edge when making a finish cut. Use 350-500 RPM on a 14" (355.6 mm) diameter cutterhead. See Bulletin C49.

6301V



A round 3/8" (9.52 mm) IC, double sided, ceramic insert. For use on cast iron heads with pre-combustion chambers. You can make one finish cut and two rough cuts with each new cutting edge. Always use a new edge when making a finish cut. Use 350-500 RPM on a 14" (355.6 mm) diameter cutterhead. See Bulletin C49.

## SPECIAL TOOLHOLDER AND INSERT FOR SURFACING

### DIESEL ALUMINUM HEADS WITH STEEL PRE-CHAMBERS

7202X



Fly Cutter Tool Holder Assembly uses special 7202Z insert for surfacing aluminum cylinder heads with steel pre-combustion chambers.

7202Z



Round Insert, 3/8" (9.52 mm) IC gold coated for aluminum cylinder heads with steel pre-combustion chamber. For use with 7202X tool holder only. RPM speeds with 14" (355.6 mm) cutter range from 450-550 RPM and with a 16" (406.4 mm) cutter, 400-500 RPM. Requires very slow feed rate. Surfacing these heads is a difficult operation and only the minimum amount of material can be removed per pass. For best results, rotating the insert so that a new 'corner' is used for the final pass should give good results.

## INSERTS FOR SHELL MILLING CUTTERHEADS

### 6514T

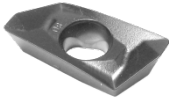

Parallelogram configuration, carbide material. Special insert used with the Rottler 650-2-44P 4" (101.6 mm) shell mills only. Designed for general purpose applications.

## MAIN LINE BORING INSERTS

Use the same RT series inserts as defined under cylinder boring. Depending on type of toolholder, either 1/4" (6.35 mm) IC or 3/8" (9.52 mm) IC inserts will be required. Commonly 1/64" (.8 mm) radius inserts are used for rough or heavy cutting, and 1/32" (.4 mm) radius inserts are used for finish boring for a smooth surface finish. In extreme conditions where the material is hard or the tool is extended and prone to chatter, use the 1/64" (.8 mm) inserts.

## CONNECTING ROD INSERTS

Many customers have reported good results boring connecting rods with Rottler RT inserts. When boring small end bearings made of bronze, the RTF series of inserts should be used.

## Machine Parts

### Front Sheet Metal

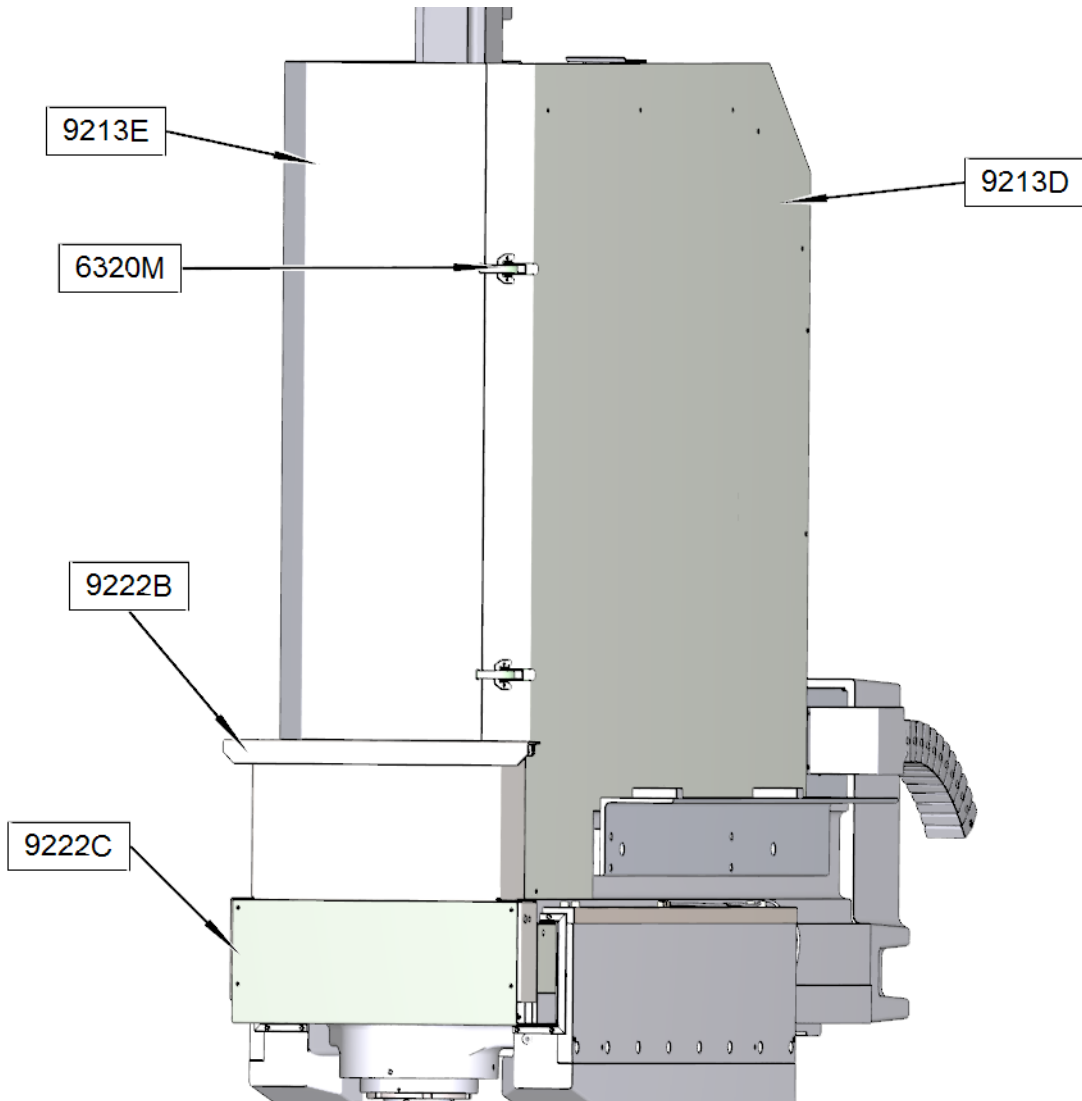

**Rear Left Sheet Metal**

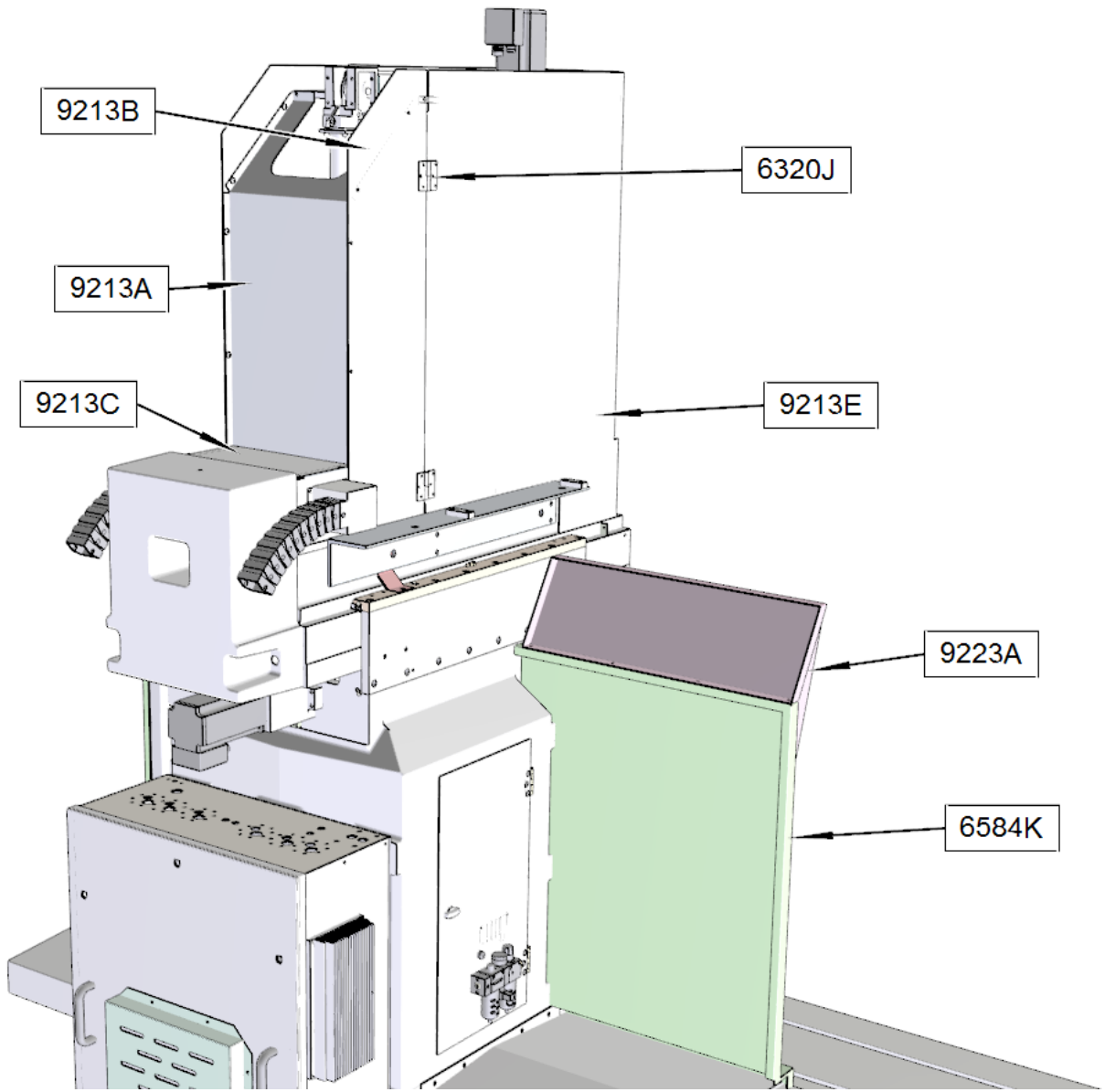

### Right Rear Sheet Metal

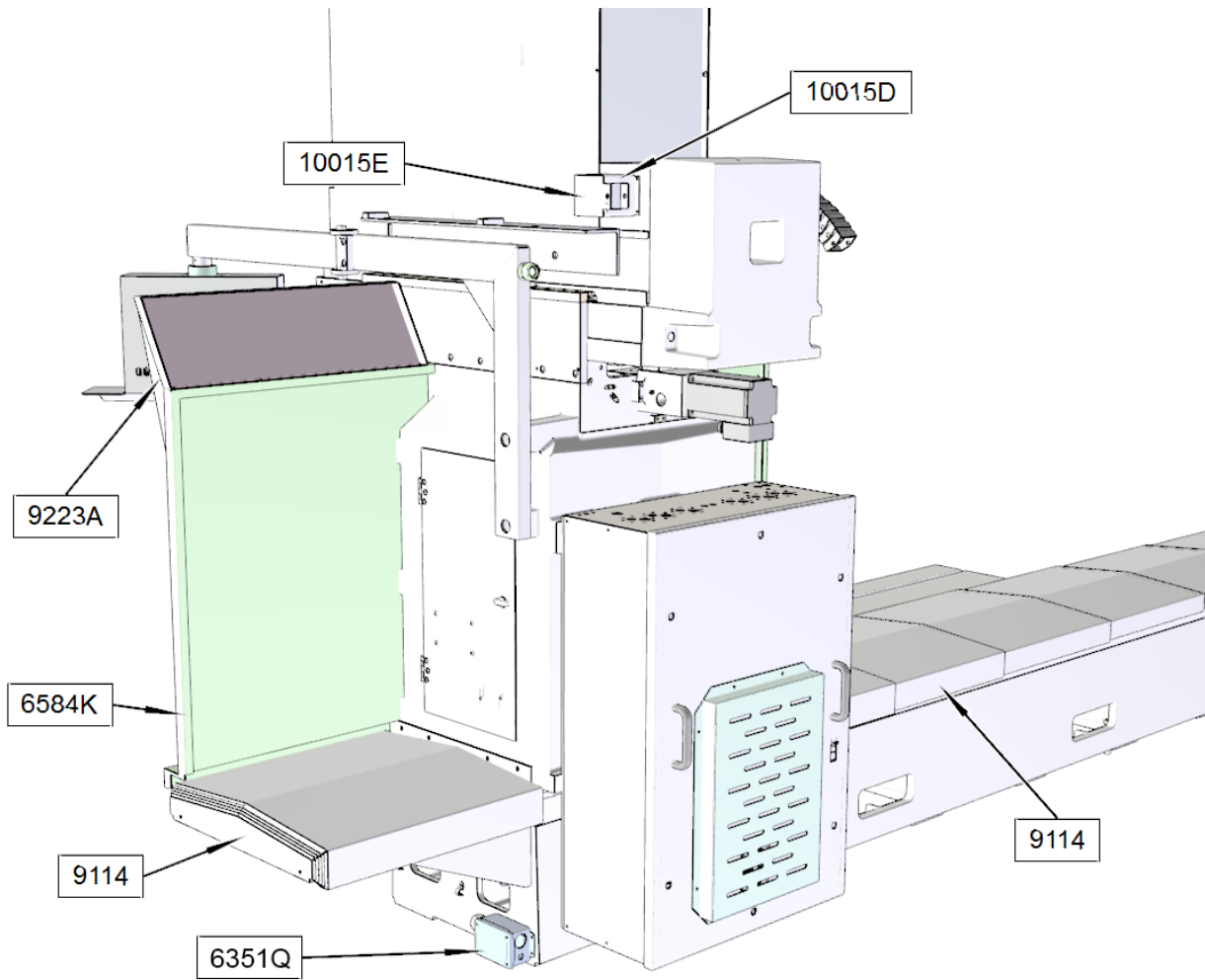

**Air Control Door**

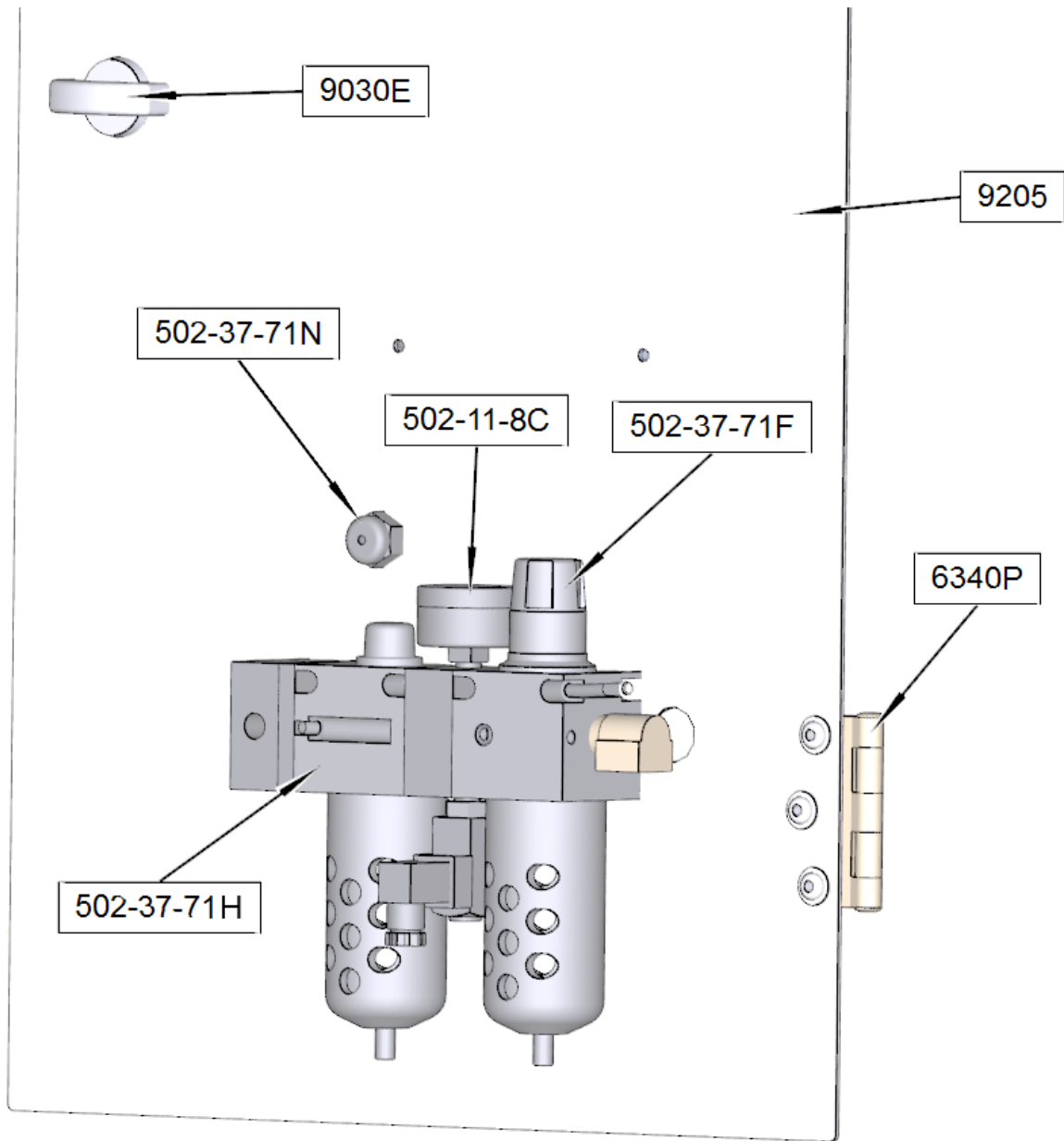



### Air Control Solenoid Pack

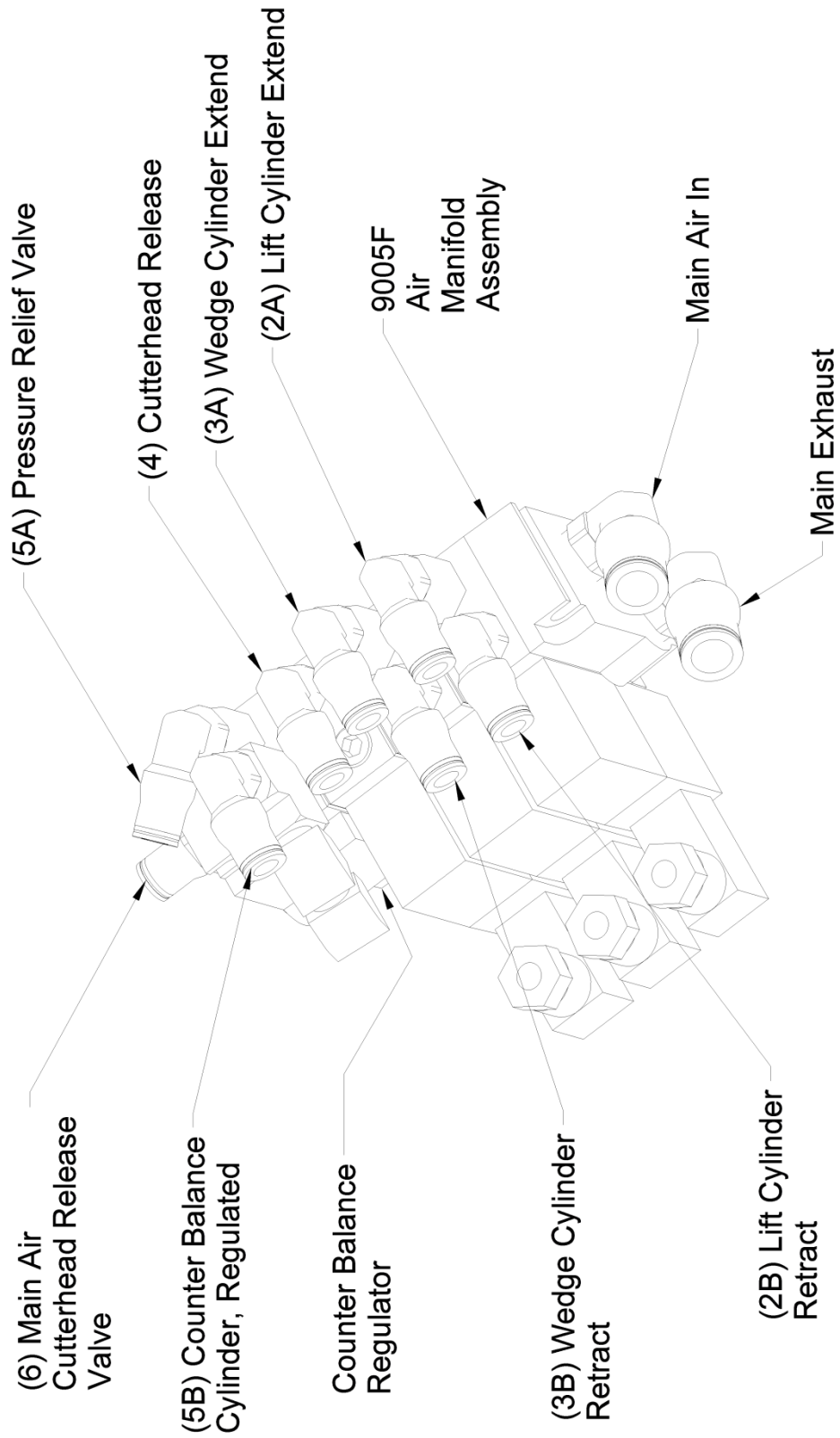

**Oiler Door**

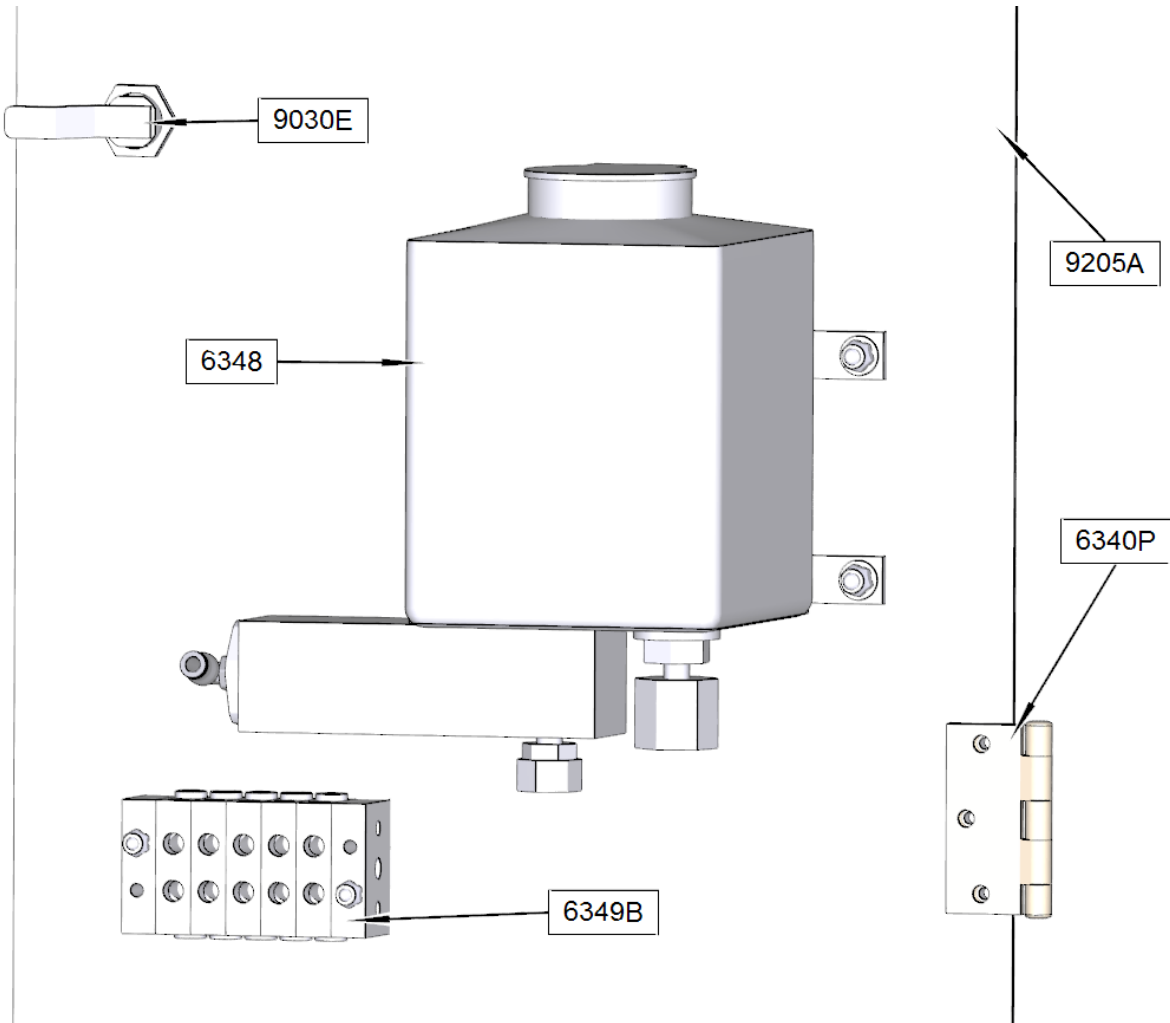

### Electrical Wiring Diagram

A scalable version of this wiring diagram is located on the manual CD.

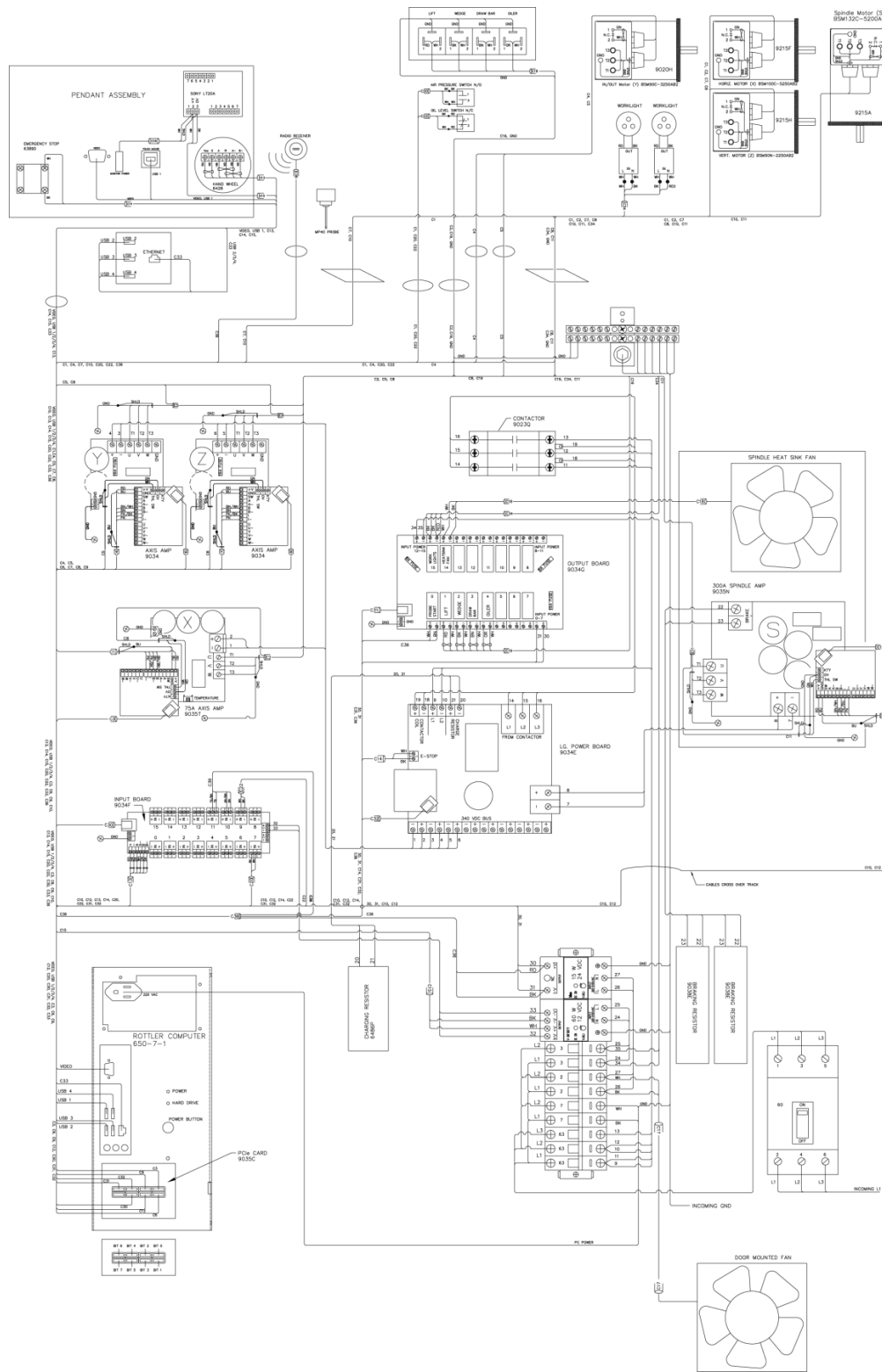

### Electrical Enclosure Assembly F103/4/5M Series

#### Enclosure Door

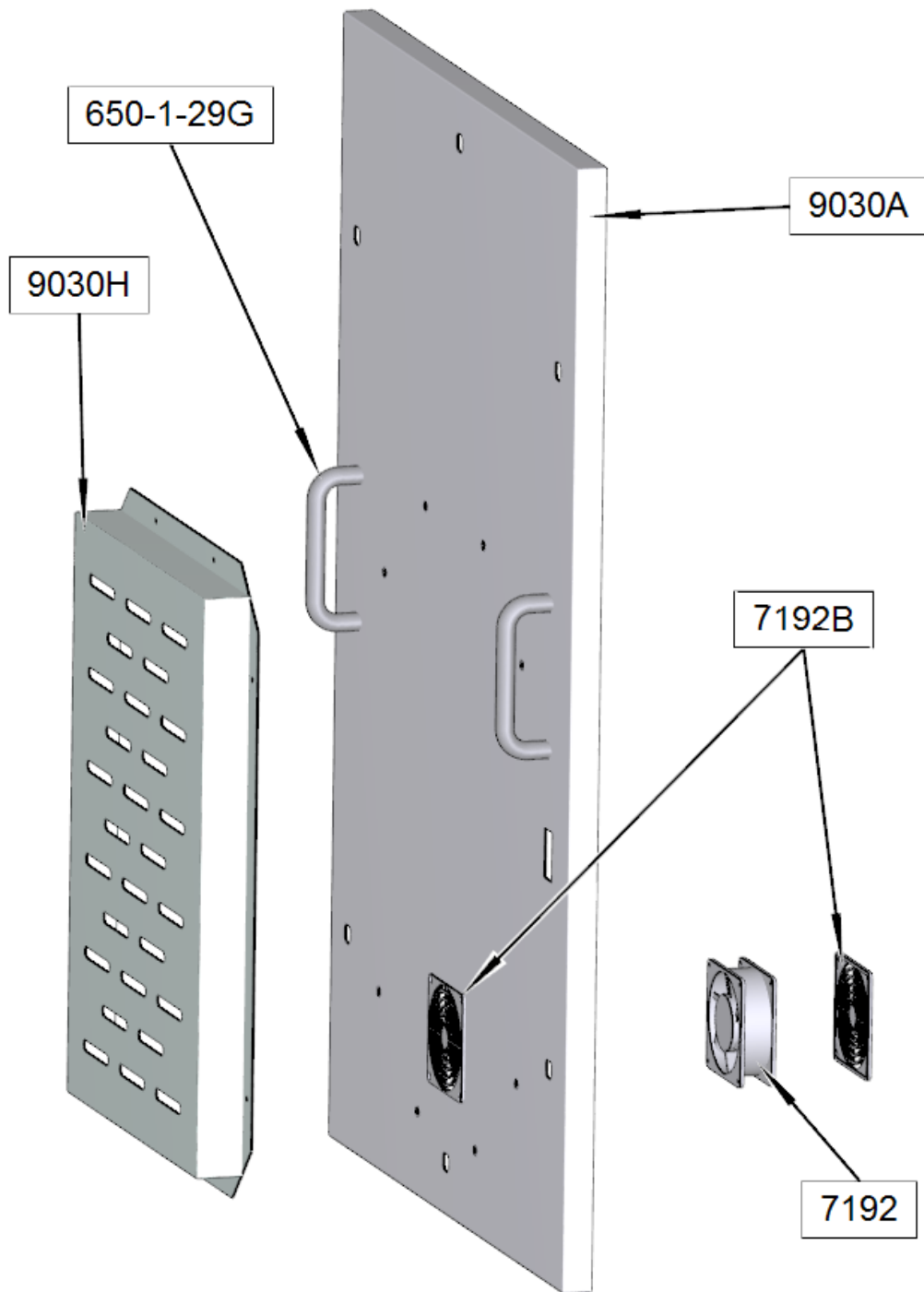

**Enclosure**

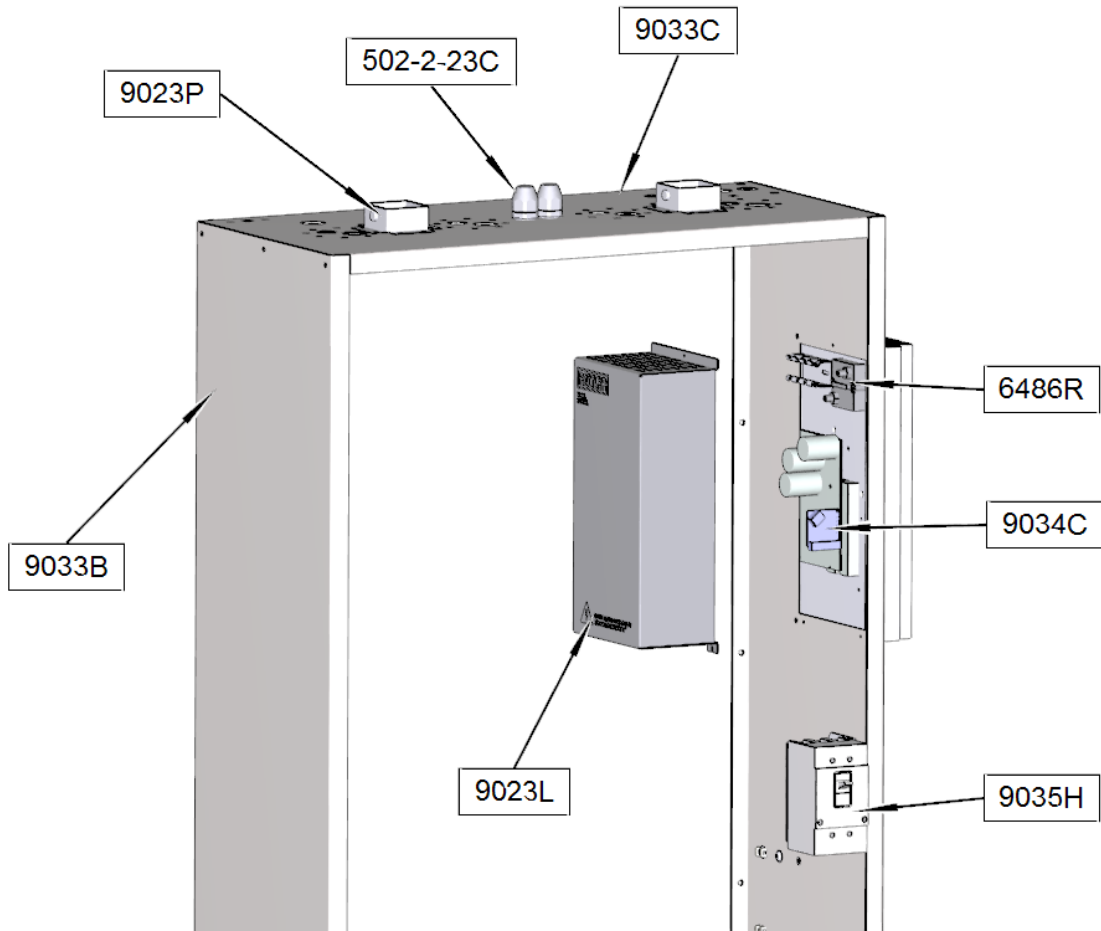

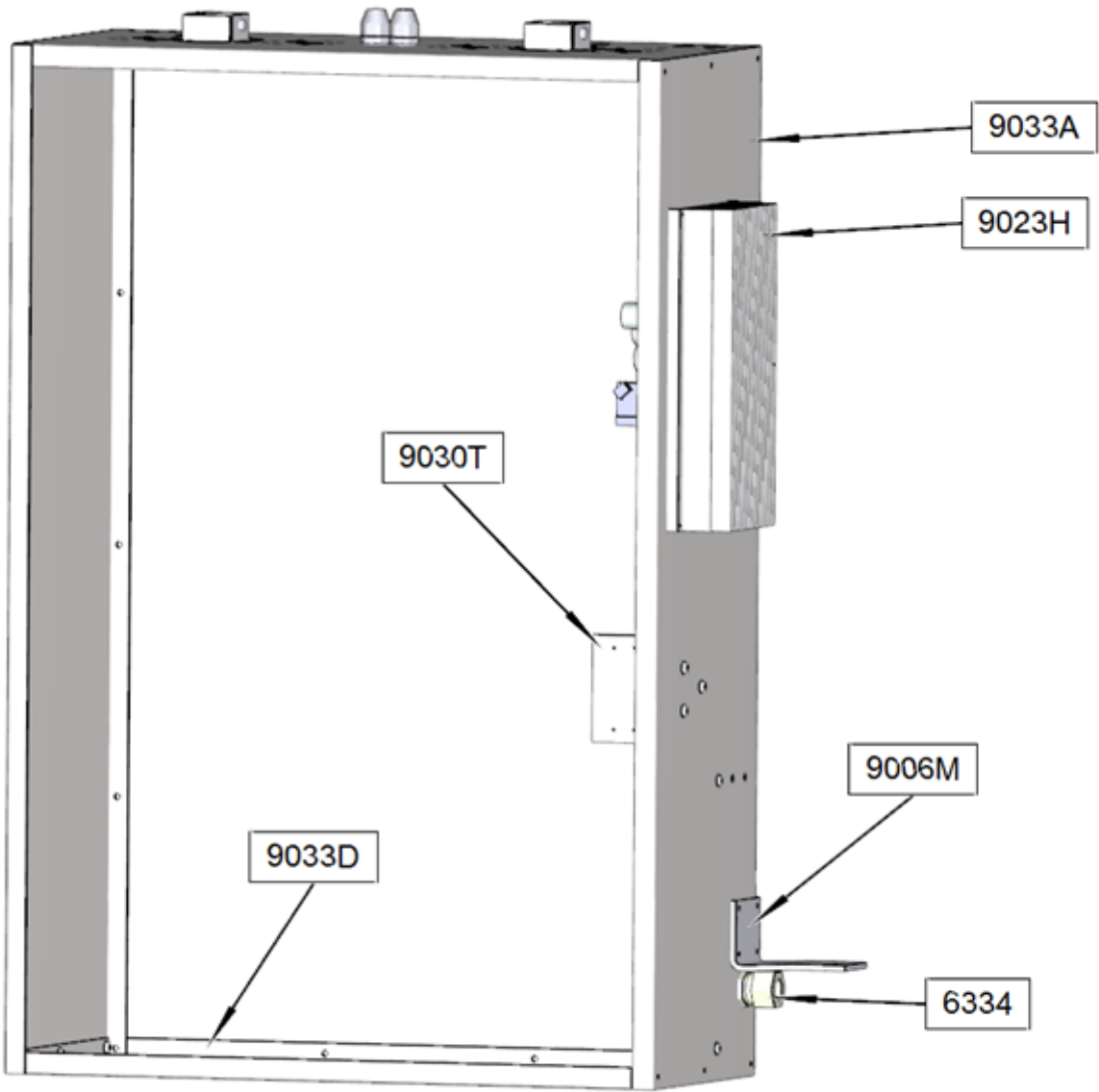

### Enclosure Panel

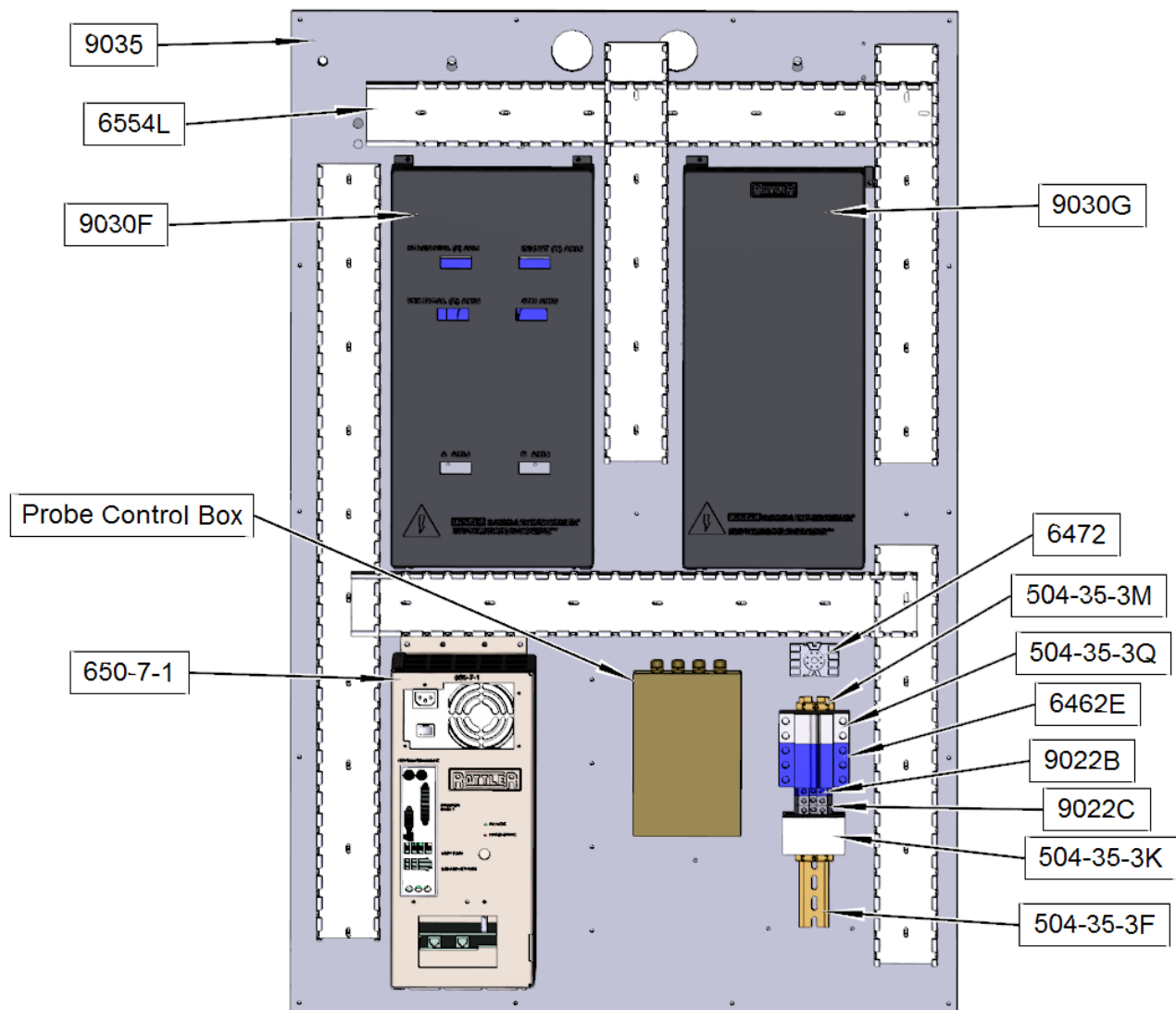

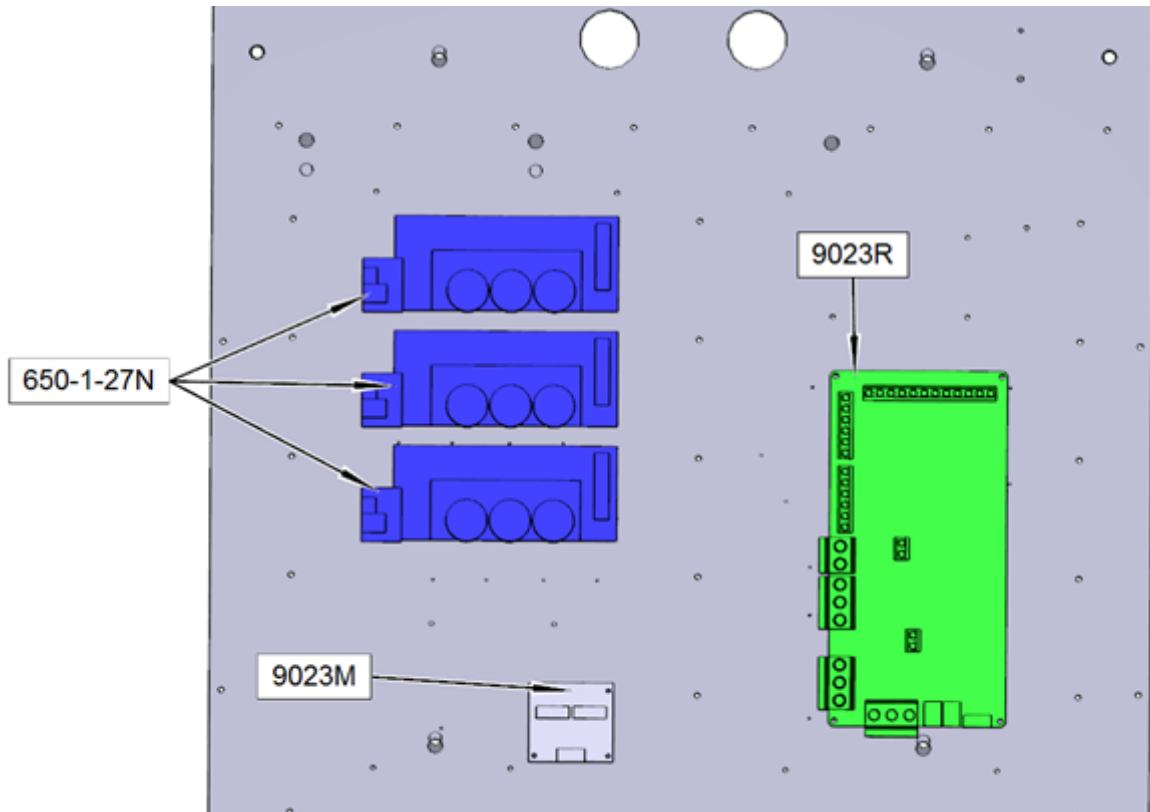



**650-1-27X Computer Enclosure Assembly**

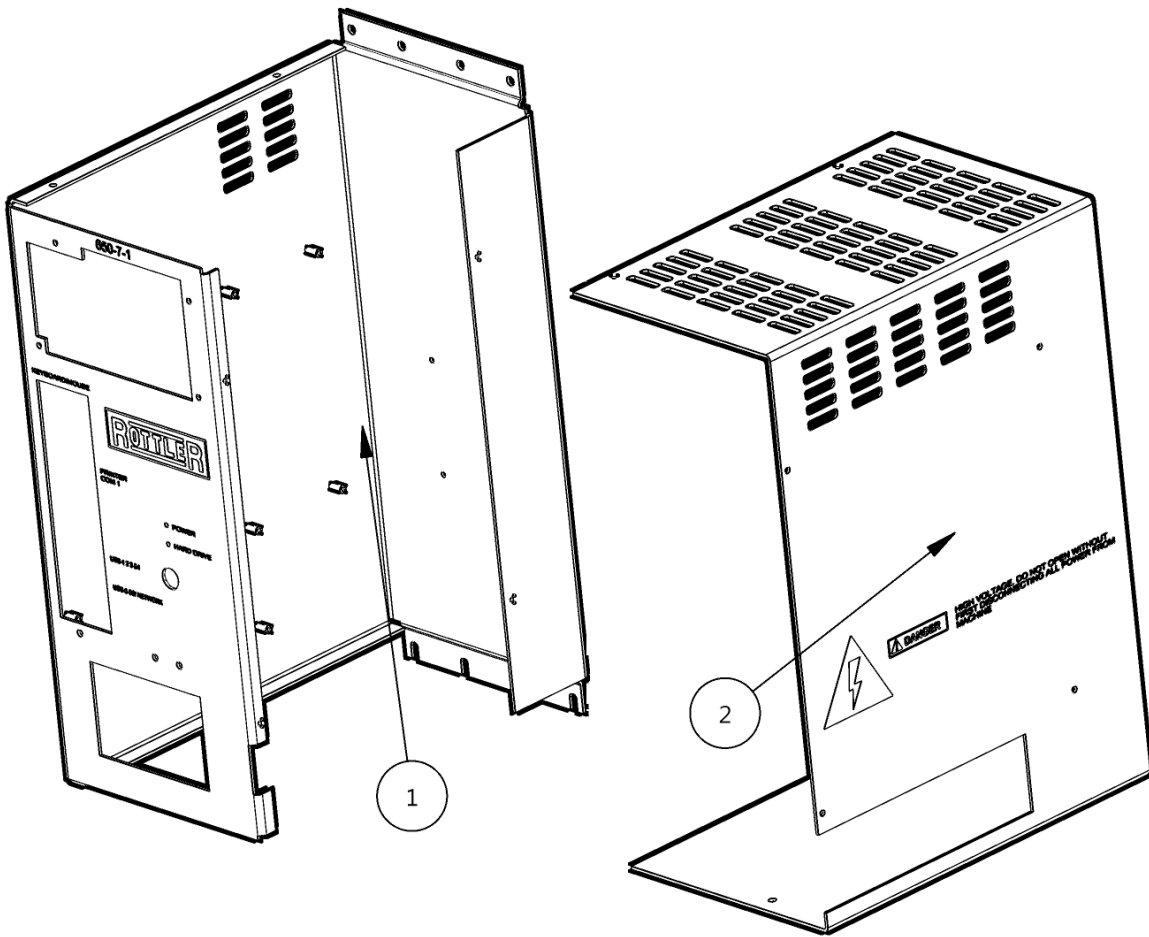

Item	Part Number	Description	Item QTY
1	650-1-27Y	Computer Case, Front	1
2	650-1-27Z	Case, Computer, Side	1

**650-7-1 Computer Components:**

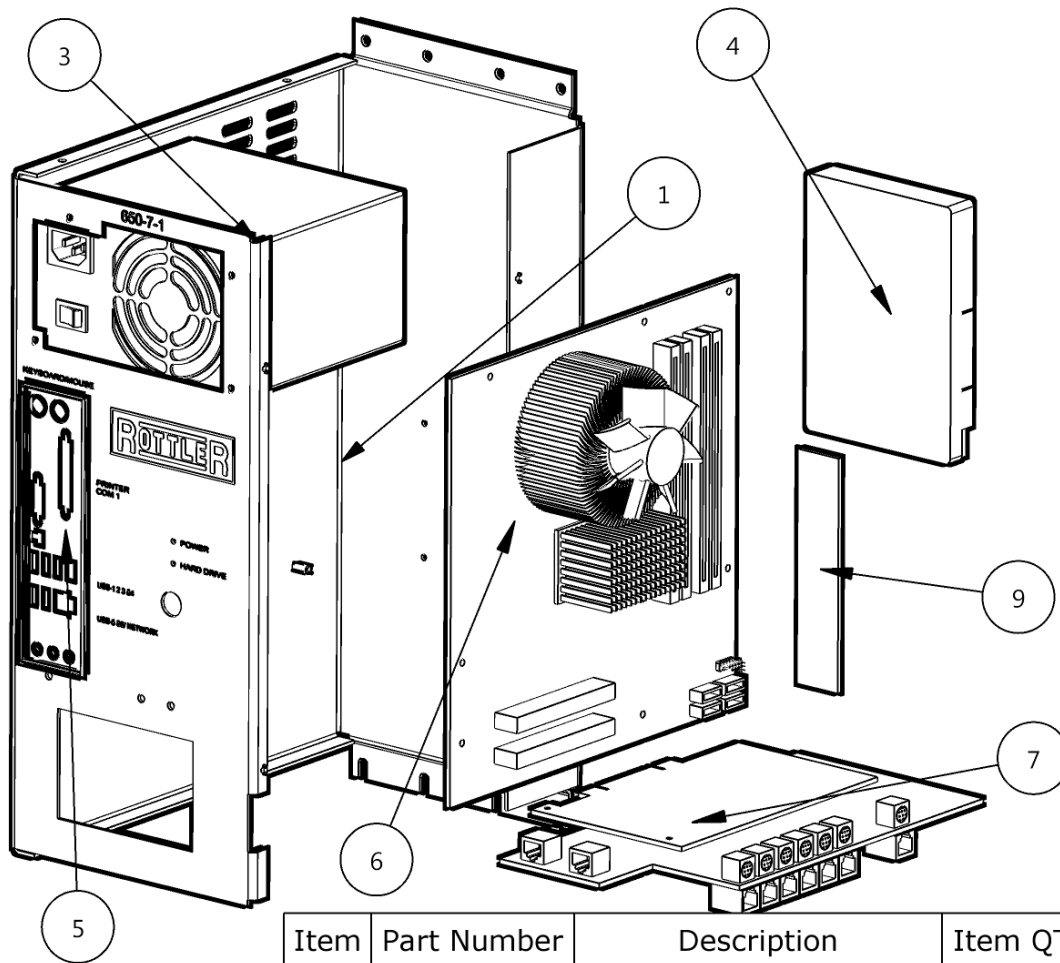

Item	Part Number	Description	Item QTY
1	650-1-27Y	Computer Case, Front	1
3	650-7-1C	500 W Power Supply	1
4	650-7-1F	Hard Drive	1
5	650-7-1A-1	Face Plate, Motherboard	1
6	650-6-1A		1
7	650-1-27Q	Interface card	1
9	650-7-1B	512 Mb DDR2 Ram	1

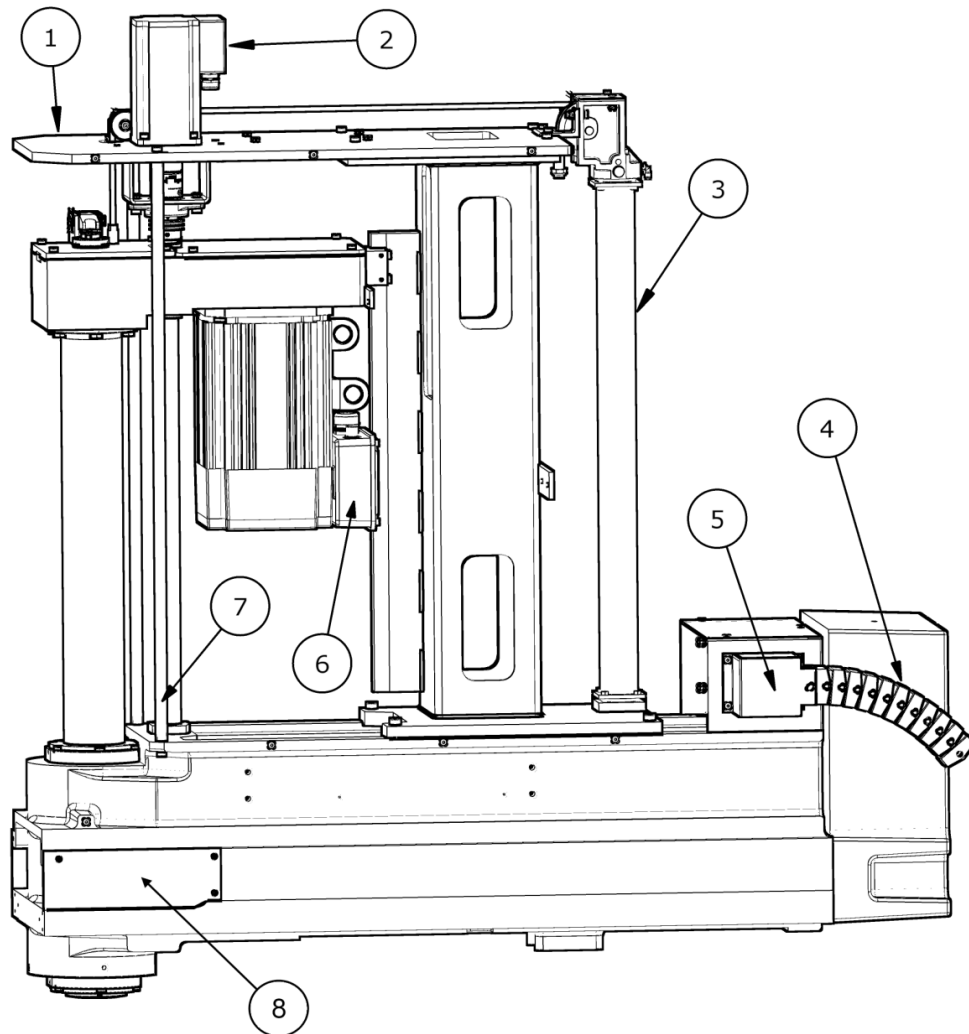
**Spindle Base, Right Side**

SPINDLE BASE ASSY RIGHT SIDE PARTS			
ITEM	PART NUMBER	DESCRIPTION	QTY
1	9208	Top Plate	1
2	6481G	Y-Axis Servo Motor	1
3	9217	Counter Balance Cylinder	1
4	9231C	Wiring Track	1
5	10015E	Wire Track Mount	1
6	9215A	Spindle Motor	1
7	9208B	Support Bar	2
8	10013F	Right Side Cover	1

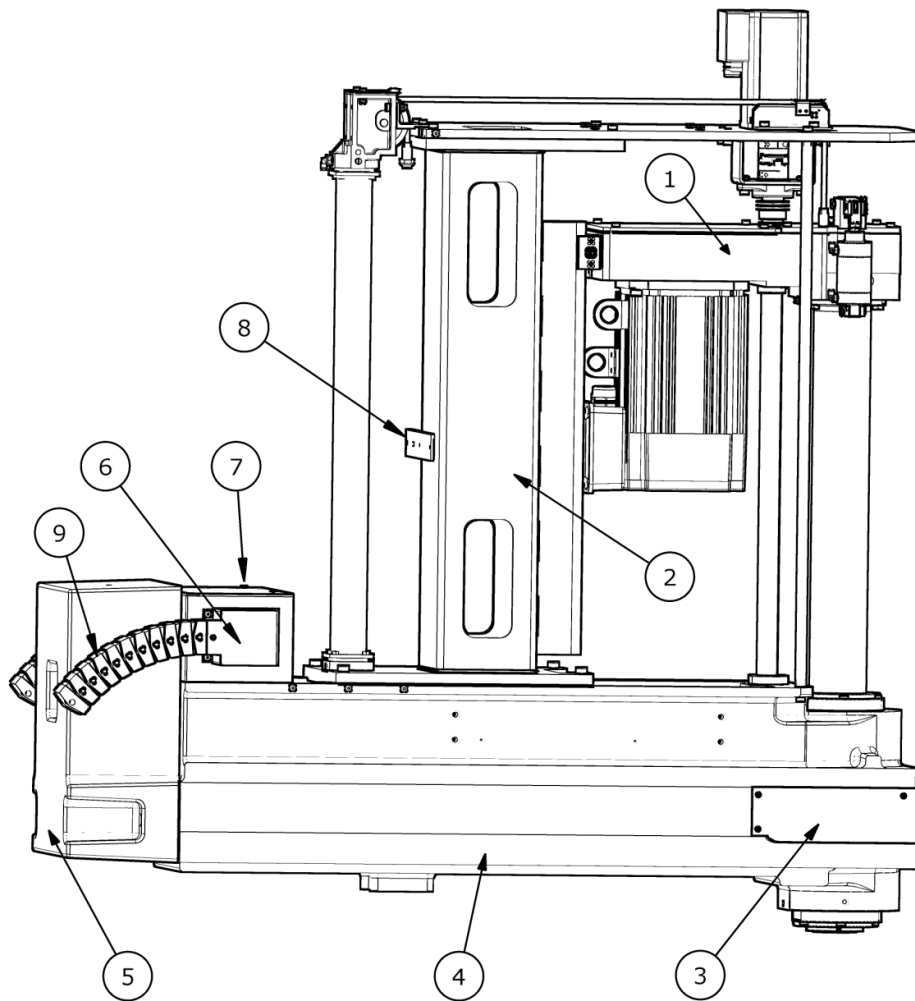
**Spindle Base, Left Side**

SPINDLE BASE ASSY LEFT SIDE PARTS			
ITEM	PART NUMBER	DESCRIPTION	QTY
1	9216	Upper Housing	1
2	9207A	Tower	1
3	10013E	Left Side Cover	1
4	9206B	Spindle Base	1
5	9206D	Counterweight	1
6	10015E	Wire Track Mount	1
7	9213	Cover Box	1
8	9231	Bracket	1
9	9231C	Wire Track	1

### Motor Housing Parts

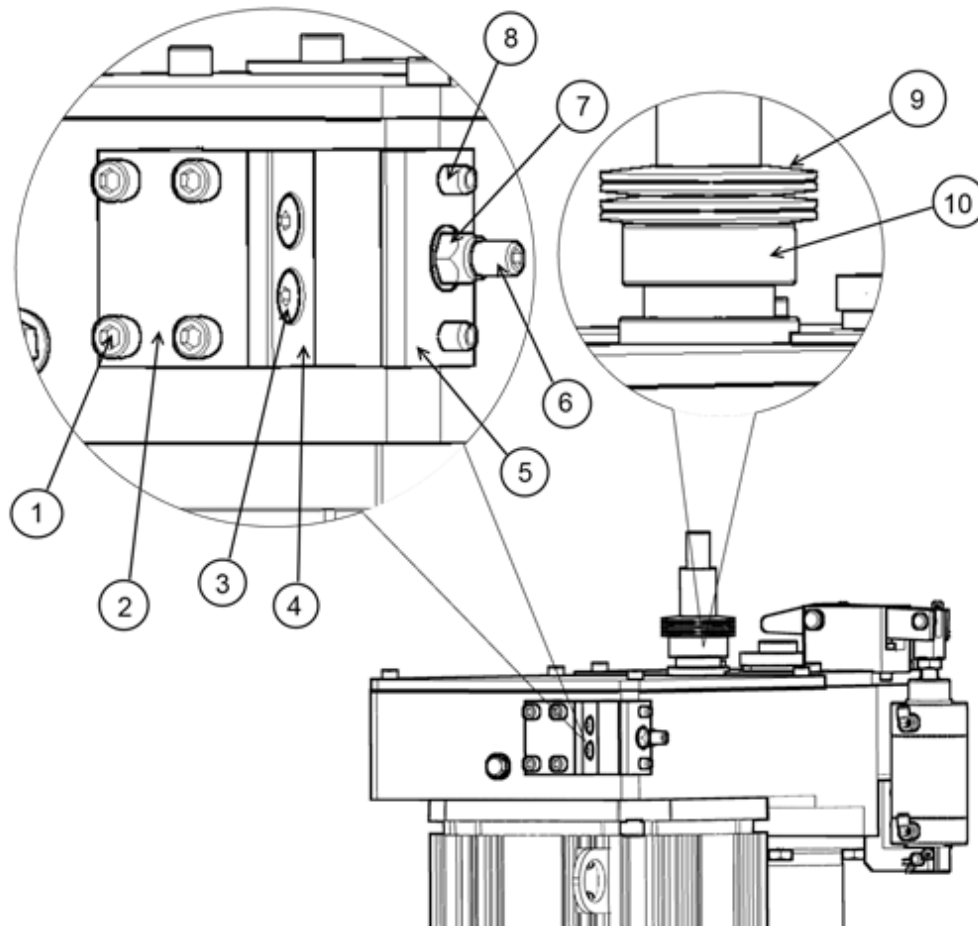

MOTOR HOUSING PARTS			
ITEM	PART NUMBER	DESCRIPTION	QTY
1		SHCS 3/8 16 X 3	4
2	6760J	Mounting Bracket	1
3		FHCS 5/16 18 X 3/4	2
4	6760K	Inner Linear Guide	1
5	6760L	Outer Linear Guide	1
6		SSS Cup Point 3/4 16 X 2	1
7		NyLok Nut 3/8 16	
8		Roll Pin 5/16 X 1 1/2	2
9	6037C	Belleville Spring	4
10	6037D	Stop Collar	1

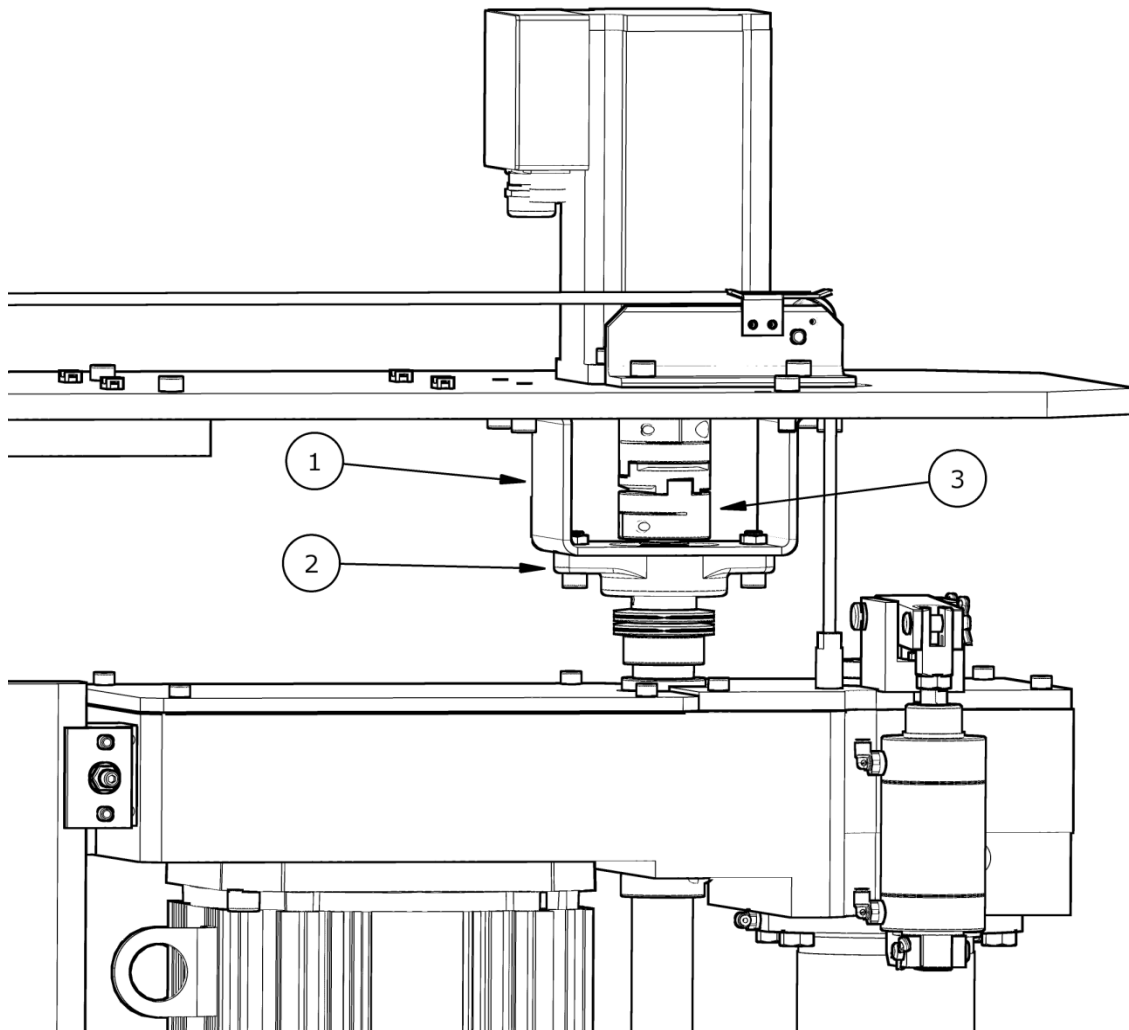
**Z-Axis Motor Parts**

Z-AXIS MOTOR PARTS			
ITEM	PART NUMBER	DESCRIPTION	QTY
1	9208C	Bearing Support	1
2	6759F	Bearing Block	1
3	9001M	Motor Coupler Assembly	1

### Spindle Motor Housing Parts Outside

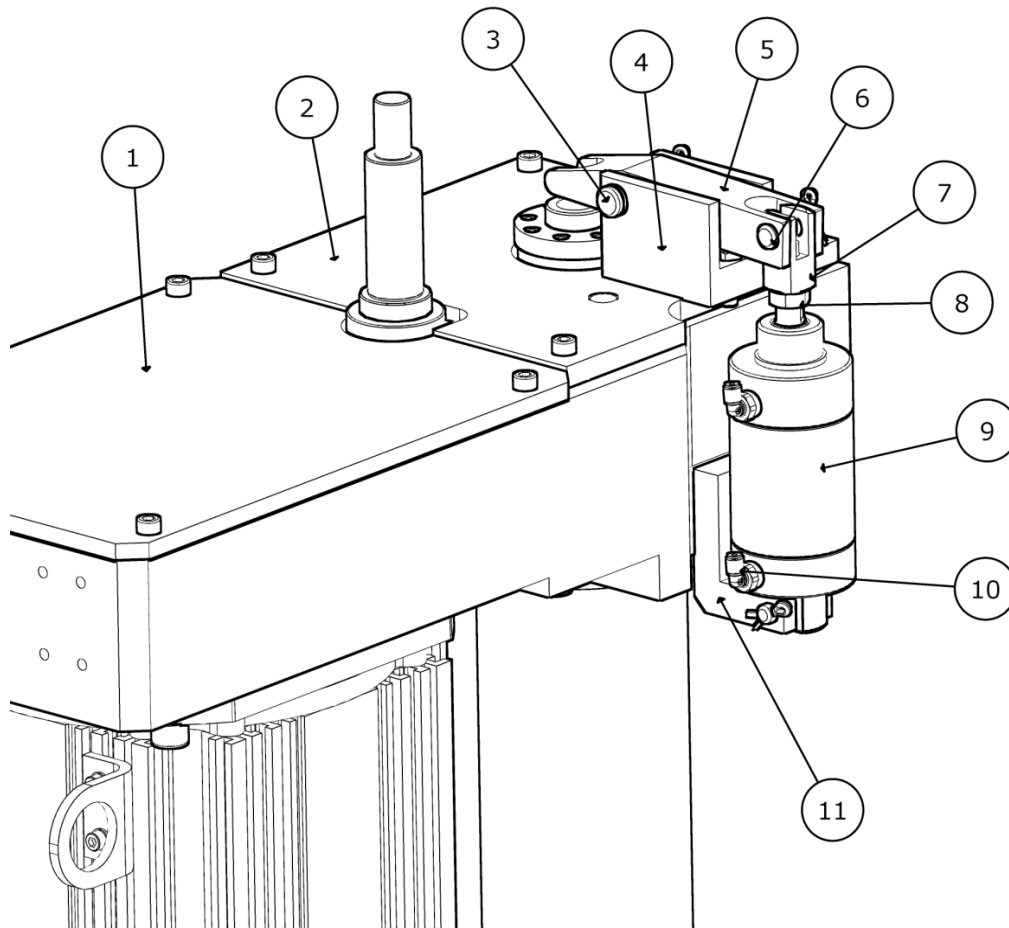

SPINDLE MOTOR HOUSING OUTSIDE PARTS			
ITEM	PART NUMBER	DESCRIPTION	QTY
1	9216C	Rear Cover	1
2	9216B	Front Cover	1
3	7210B	Clevis Pin	1
4	6174B	Support Bracket	1
5	6173B	Actuator Arm	1
6	6189B	Clevis Pin	2
7	6205	Clevis	1
8		1/2 20 Jam Nut	1
9	6204A	Cylinder	1
10	514-4-17Z	90° 1/8 Tube Fitting	2
11	6188C	Cylinder Bracket	1

### Spindle Motor Housing Parts Inside

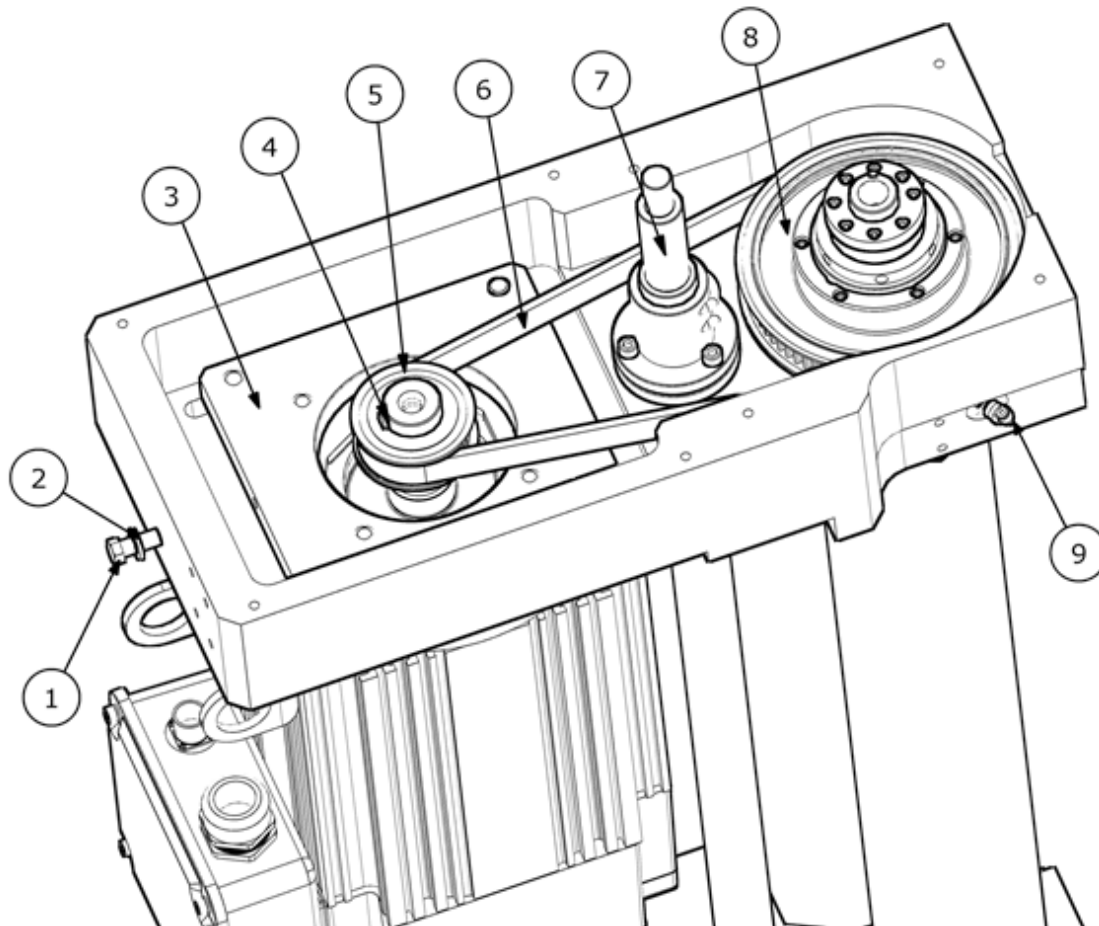

SPINDLE MOTOR HOUSING INSIDE PARTS			
ITEM	PART NUMBER	DESCRIPTION	QTY
1		Hex Bolt 3/8 16 X 2 3/4	1
2		3/8 Flat Washer	1
3	9216A	Motor Mount Plate	1
4		Drive Key	1
5	9215B	Drive Sprocket	1
6	9215N	Belt	1
7	9209	Ballscrew and Ball Nut Assy	1
8	9215M	Driven Sprocket	1
9	514-4-18	90° 1/8 Tube Fitting	1



### Upper Spindle & Ballscrew Parts

\* See Maintenance Section for correct installation procedure

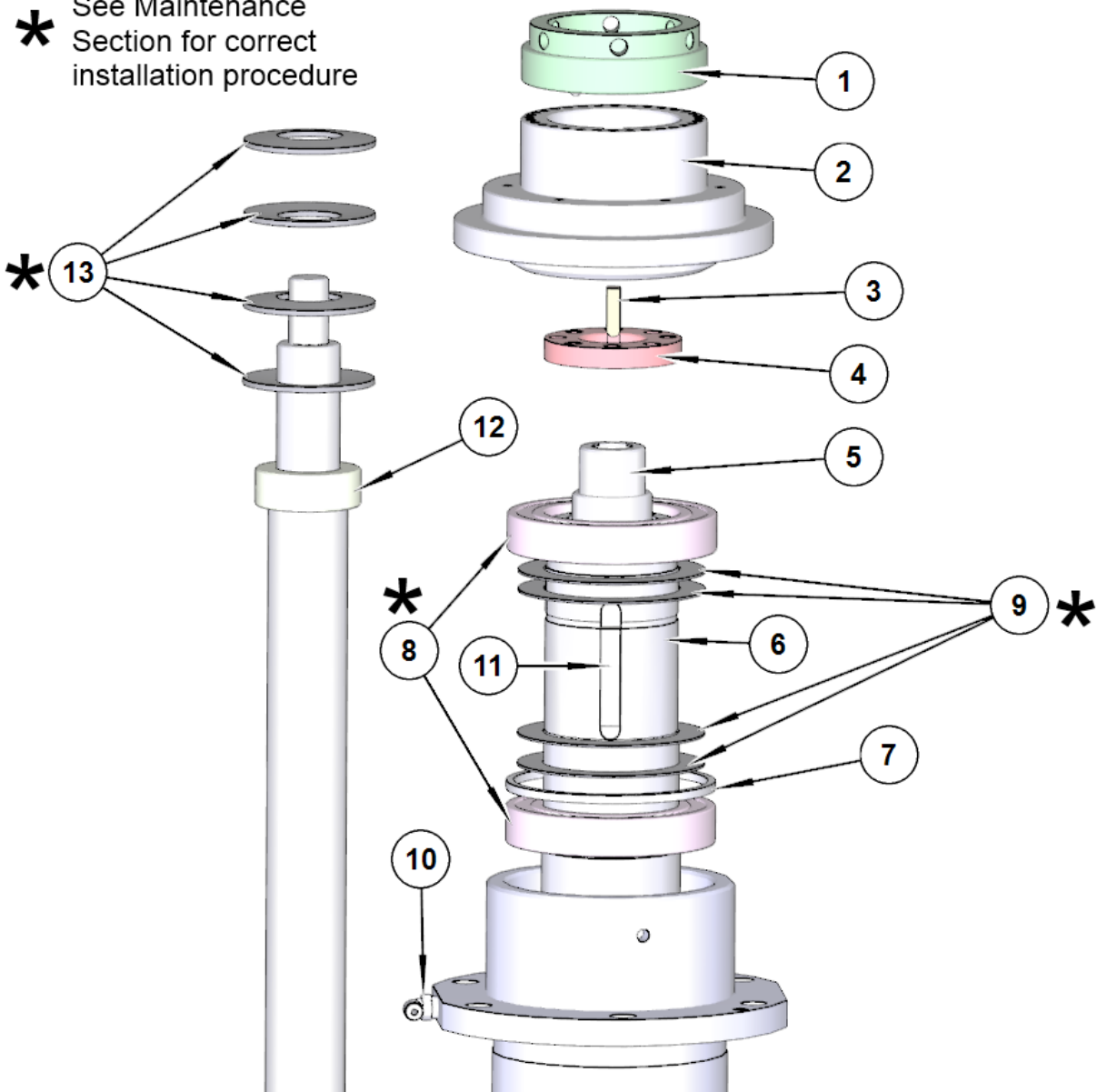

<b>UPPER SPINDLE &amp; BALLSCREW PARTS</b>			
<b>ITEM</b>	<b>PART NUMBER</b>	<b>DESCRIPTION</b>	<b>QTY</b>
1	9218A	Spindle Nut	1
2	9218	Index Bushing	1
3	6186	Lock Key	1
4	6180A	Cap	1
5	9028	DRAWBAR--SOLD IN ASSY 9028B ONLY	1
6	6167N	INNER SPINDLE ASSY (SOLD IN ASSY #6167G ONLY)	1
7	6123F	Spacer	1
8	6115A	Bearing	2
9	6113	BELLEVILLE SPRING	4
10	514-4-18	90° 1/8 Tubing Fitting	1
11	6090B	Drive Key	1
12	6037D	Collar Spacer	1
13	6037C	BELLEVILLE SPRING	4

### Lower Spindle & Ballscrew Parts

\* See Maintenance section for correct installation procedure

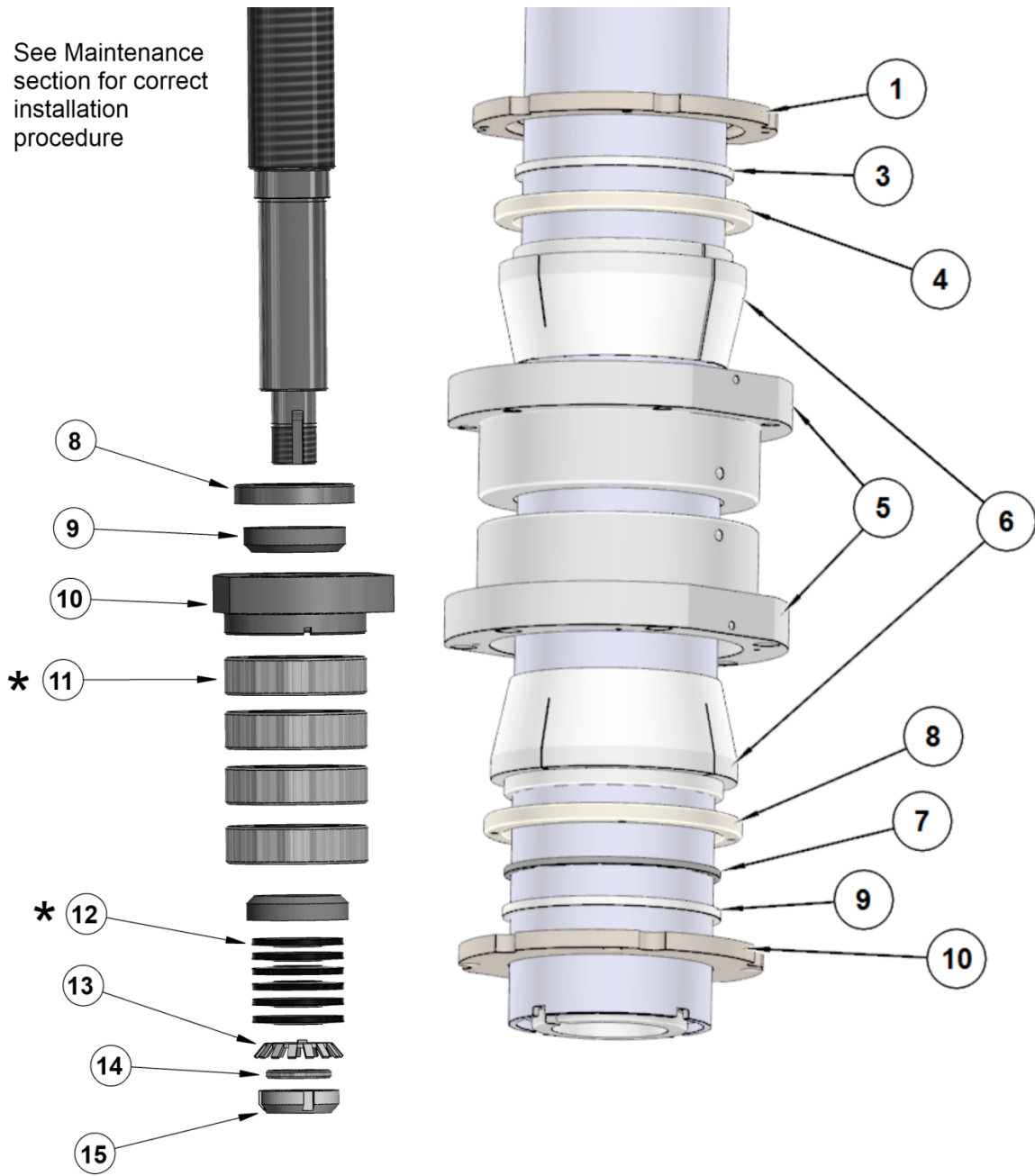

<b>LOWER SPINDLE &amp; BALLSCREW PARTS</b>			
<b>ITEM</b>	<b>PART NUMBER</b>	<b>DESCRIPTION</b>	<b>QTY</b>
1	6247A	Wiper Retainer	2
3	6249	Oiler Felt	2
4	6223	Spindle Nut	2
5	6225A	Bearing Carrier	2
6	6222A	Bushing	2
7	6248	Wiper	1
8	6052	Oil Seal	1
9	6107	Shoulder Ring	2
10	6032E	Thrust Bearing Retainer	1
11	6063	Bearing	4
12	6037A	Belleville Spring	6
13	502-10-18	Lock Washer	1
14	6049C	Keyed Washer	1
15	502-10-17	Nut Lock	1

### Inner Spindle Lower Section Parts

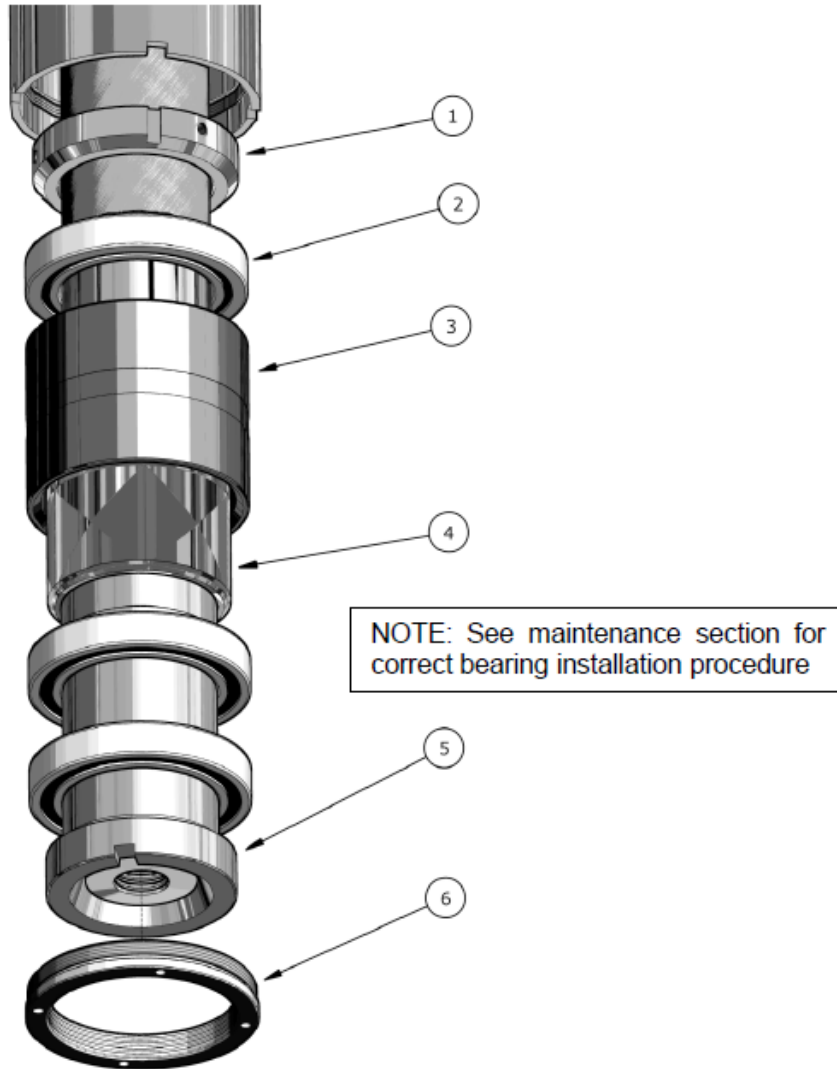

INNER SPINDLE LOWER SECTION PARTS			
ITEM	PART NUMBER	DESCRIPTION	QTY
1	6116F	NUT,BEARING-LOWER INNER SPINDLE	1
2	6116E	BEARING,PRECISION- SPINDLE (SET OF 3)	1
3	6172D	SPACER,PRECISION BEARING OUTER SPINDLE SOLD IN	1
4	6172C	ASSY#6172E	
5	6167G	SPINDLE, INNER ASSY-PRECISION BEARING STYLE	1
6	6305D	NUT,THROW BACK RING	1

**Y-Axis Drive Parts**

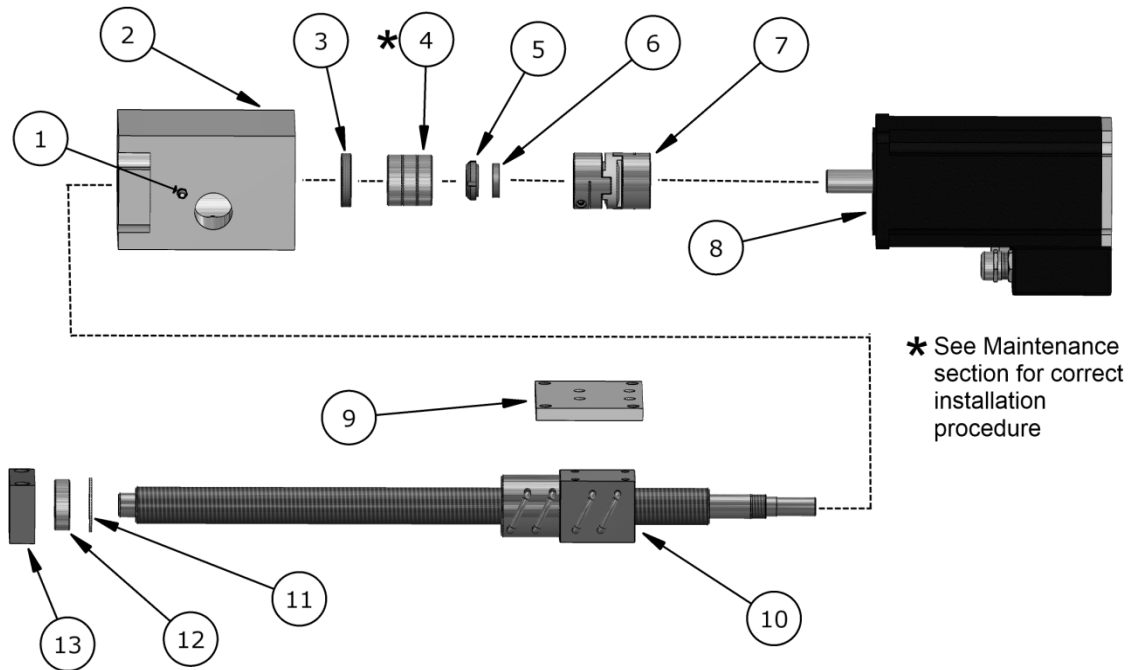

Y-AXIS DRIVE PARTS			
ITEM	PART NUMBER	DESCRIPTION	QTY
1	MF-191A	Grease Fitting	1
2	11008A	Direct Drive Motor Housing	1
3	504-34-15A	Thrust Nut	1
4	6778D	Bearing	3
5	504-34-54	Locknut	1
6	504-34-53	Oil Seal	1
7	9001M	Coupler Assembly	1
8	6481G	Servo Motor	1
9	10019	Ballscrew Nut Mount	1
10	9201A	Ballscrew and Nut Assembly	1
11	7245E	Snap Ring	1
12	6778D	Bearing	1
13	9001A	Ballscrew Support	1

Column and Spindle Base Retainers

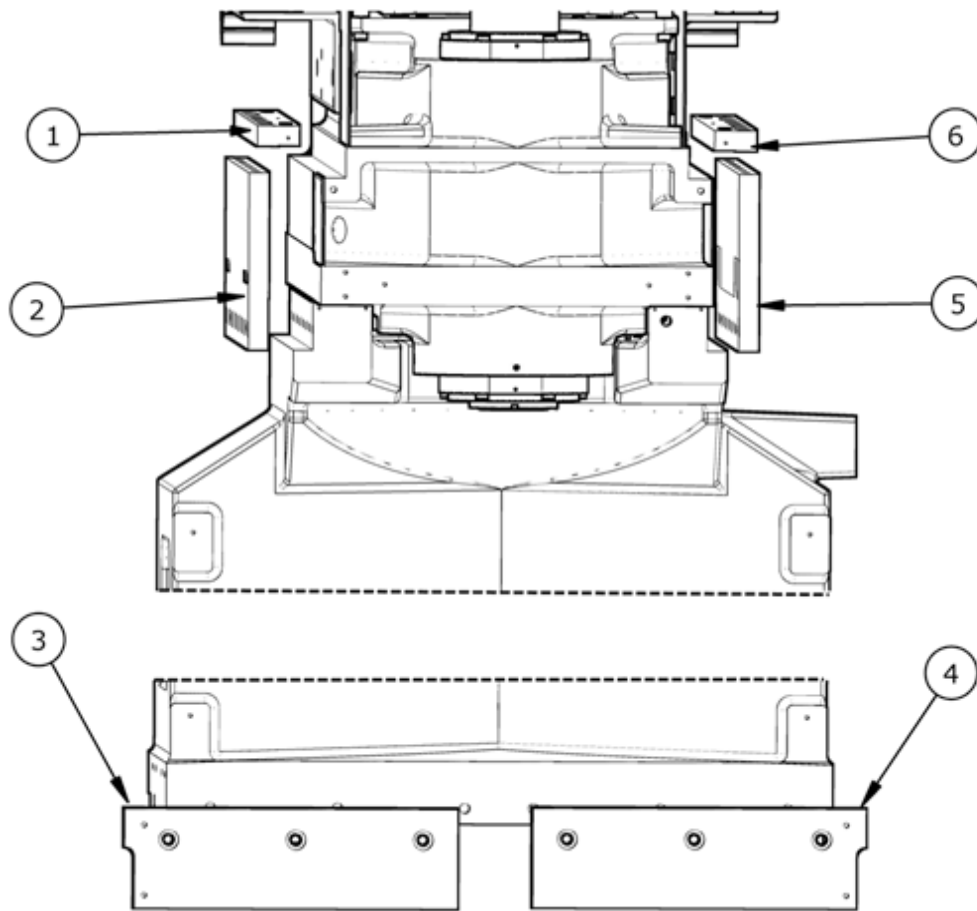

COLUMN & SPINDLE BASE RETAINERS			
ITEM	PART NUMBER	DESCRIPTION	QTY
1 & 6	9202B	Column Gib Bar Top	2
2	9202A	Left Gib Bar	1
3	6140A	Left Bearing Way	1
4	6141A	Right Bearing Way	1
5	9202	Right Gib Bar	1

**Column Slide Parts**

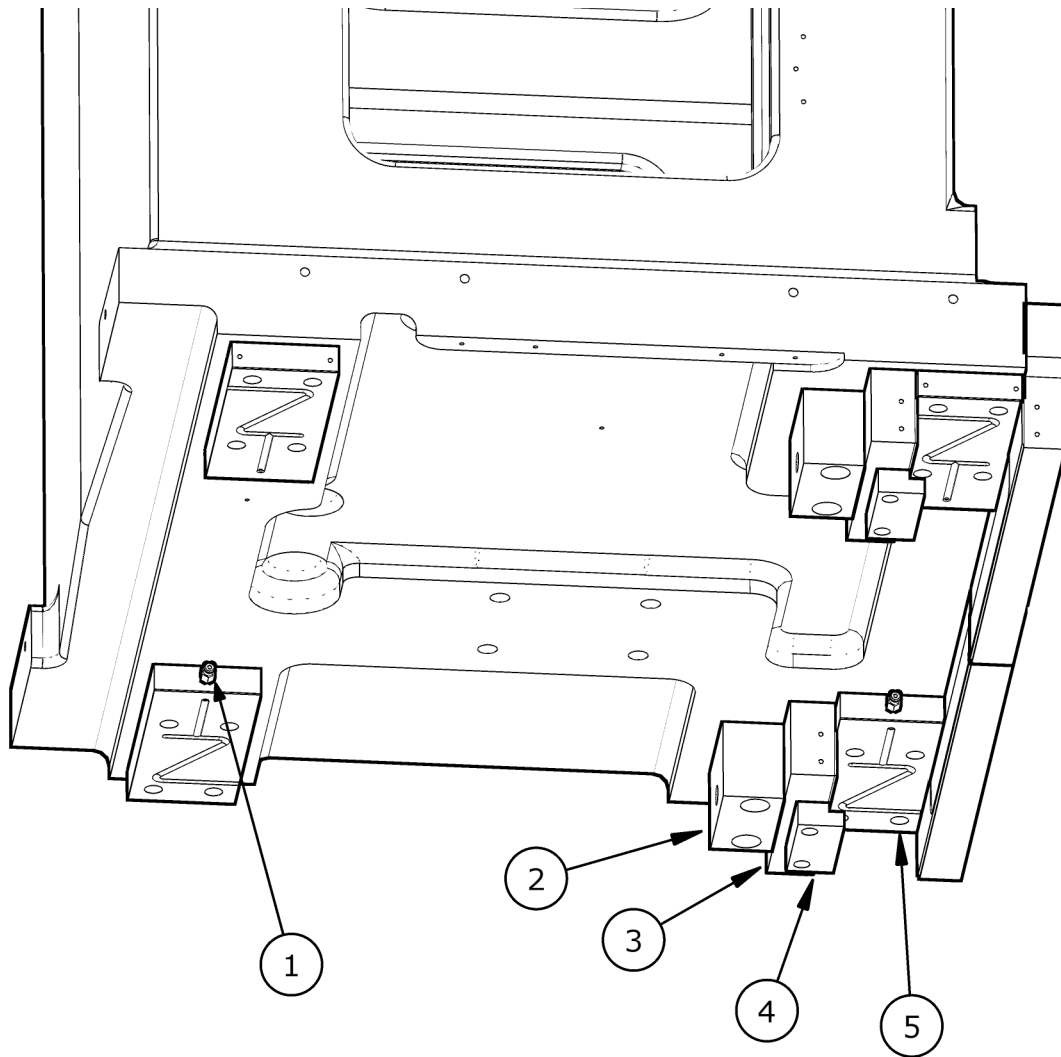

COLUMN SLIDE PARTS			
ITEM	PART NUMBER	DESCRIPTION	QTY
1	514-4-17J	1/8 Tube Fitting	4
2	6146	Adjusting Gib Plate	2
3	6144A	Column Gib	2
4	6190M	Lift Stop Bar	2
5	11007A	Column Way Bearing	4



### Pendant Swing Arm

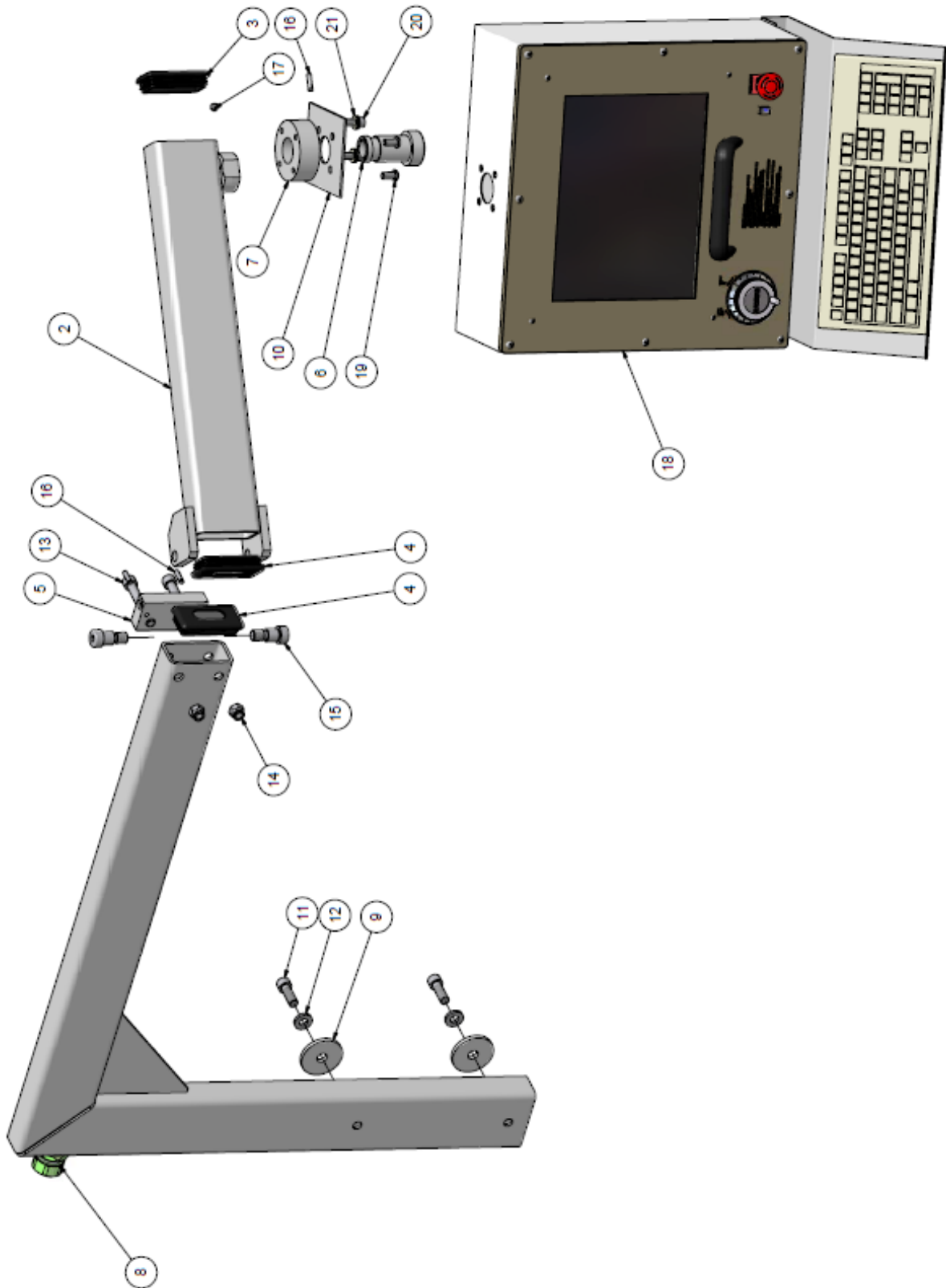

## Pendent Swing Arm Assembly Parts List

Pendant Swing Arm Assembly			
ITEM	QTY	PART NUMBER	DESCRIPTION
1	1	6201L	Swing Arm Support
2	1	6200B	Swing arm
3	1	6200J	Plug
4	2	6200L	Tubing Plug, Slotted
5	1	6201H	Hinge Block
6	1	6197B	Swivel
7	1	6198b	Swivel Housing
8	1	6358	1" Straight Sealtight Fitting
9	2	502-3-17	Washer
10	1	6385E	Support Plate
11	2	Mf-44	Socket Head Cap screw 1/2 - 13 UNC - 1 1/2
12	2	Washer	
13	2	Mf-41A	Socket Head Cap screw 1/2 - 13 UNC - 3 1/2
14	2	MF-188	Nylock Nut
15	2	6201J	Hexagon Socket Head Shoulder Screw
16	3	MF-204	Pin - Hardened Ground Machine Dowel
17	2	MF-71	Hexagon Socket Set Screw - Cup Point
18	1	Pendant Assembly	
19	2	Mf-98	Socket Button Head Cap Screw 3/8 - 16 x 3/4
20	2	Mf-31	Socket Head Cap screw 3/8 - 16 UNC - 1
21	4	100-28-32	Thrust Washer

**Pendant Assembly**

F99Y Pendant Assembly			
ITEM	QTY	PART NUMBER	DESCRIPTION
1	1	6198M	Pendant Face Plate
2	1	650-1-2G	Handle, Pendant
3	1	6428	Electronic Handwheel
4	1	6389D	E-Stop Button
5	1	6389B	E-Stop Nameplate
6	1	650-1-29M	Push Button Cover
7	1	650-1-28J	Reset Button
8	1	6198L	Pendant Enclosure
9	1	650-1-28M	Keyboard Tray
10	1	650-5-23	Keyboard
11	1	9023B	Face Plate Overlay
12	1	650-1-28X	Touch Screen

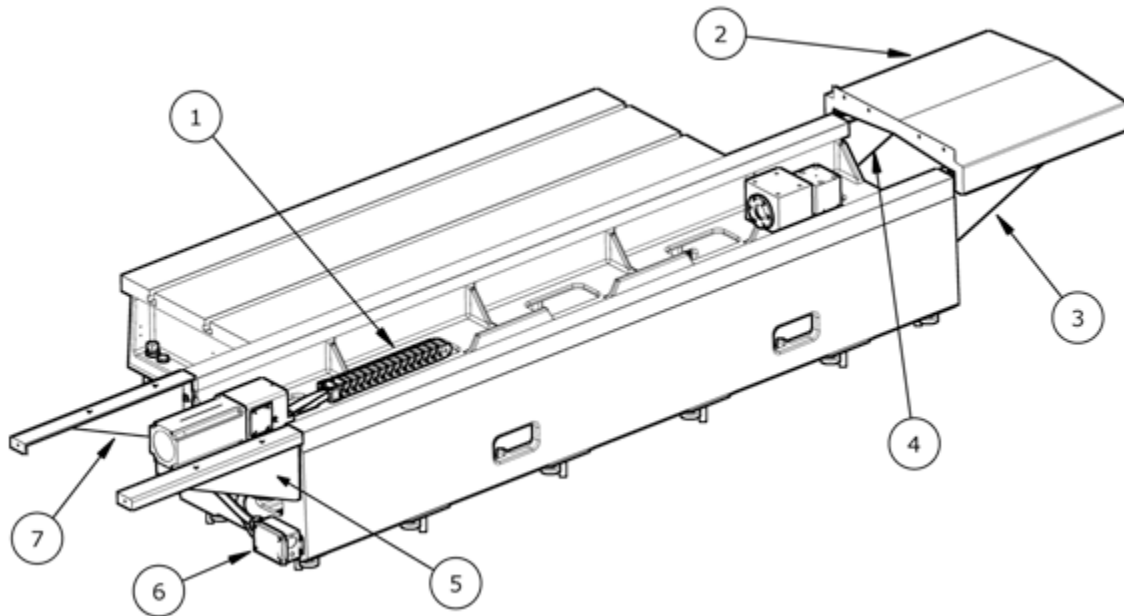

**Main Base Parts**

MAIN BASE PARTS			
ITEM	PART NUMBER	DESCRIPTION	QTY
1	9219B	Cable Carrier	2
2	9114	Way Cover Set	2
3 & 7	9011A	Left Way Cover Support	2
4 & 5	9011B	Right Way Cover Support	2
6	6351Q	Electrical Hookup Box	1

**X-Axis Assembly: Drive End**

\* See Maintenance section for correct installation procedure

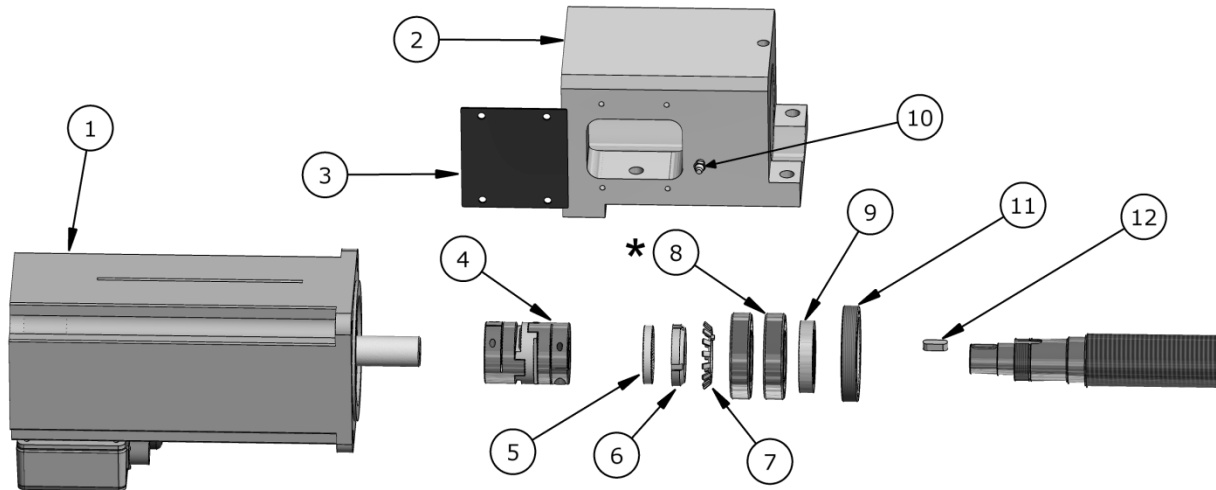

X-AXIS DRIVE END PARTS			
ITEM	PART NUMBER	DESCRIPTION	QTY
1	9215F	Servo Drive Motor	1
2	9212	Motor and Ballscrew Housing	1
3	9113D	Cover	1
4	9113E	Coupler Assembly	1
5	9113F	Seal	1
6	9113A	Lock Nut	1
7	9113B	Lock Washer	1
8	9113	Bearing	2
9	9113G	Seal	1
10	MF-191A	Grease Fitting	1
11	9113J	Bearing Nut	1
12	6073V	Drive Key	1

**X-Axis Assembly: Idle End**

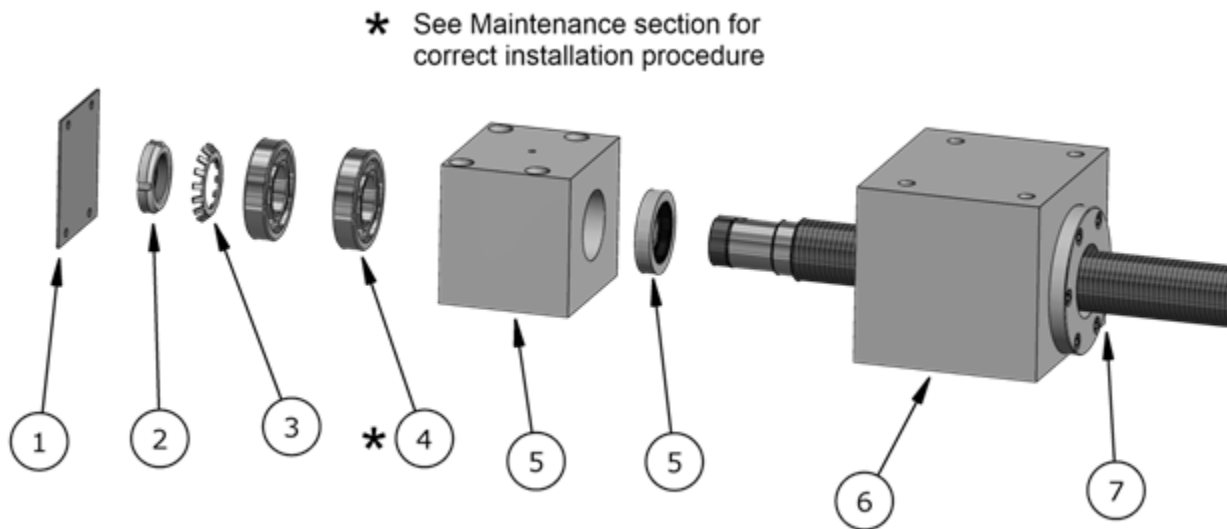

X-AXIS IDLE END PARTS			
ITEM	PART NUMBER	DESCRIPTION	QTY
1	9113D	End Cover	1
2	9113A	Lock Nut	1
3	9113B	Lock Washer	1
4	9113	Bearing	2
5	9112F	Ballscrew Support	1
6	9112D	Ballscrew Nut Mount	1
7		Ballscrew and Nut Assembly	1
8	9113G	Seal	1

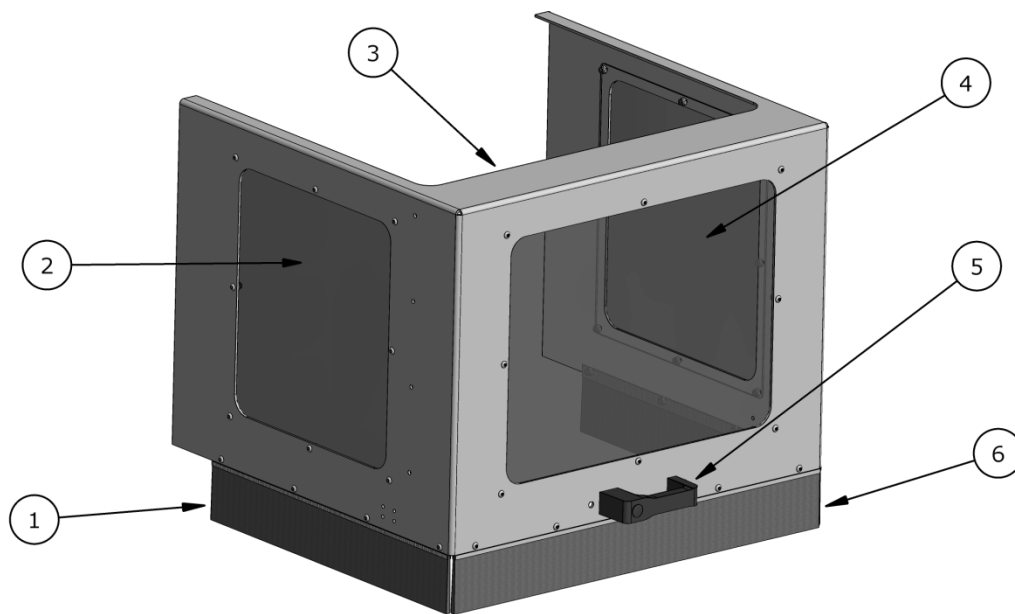
**Chip Shield Assembly**

CHIP SHIELD PARTS			
ITEM	PART NUMBER	DESCRIPTION	QTY
1	11031E	Side Brush	2
2	9221A	Side Window	2
3	9221C	Chip Shield Housing	1
4	9221B	Front Window	1
5	650-1-29G	Handle	1
6	11031H	Front Brush	1

### Front Cover and Lights

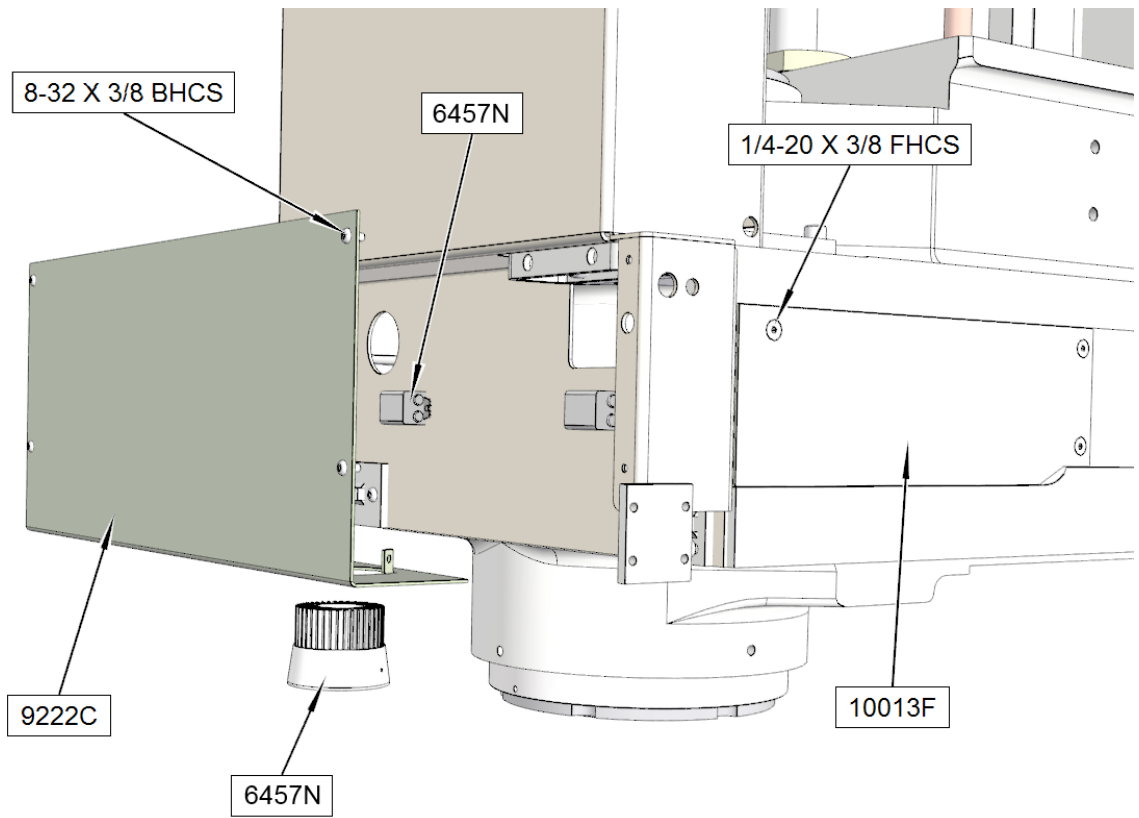



### Oil Line Diagram

A scalable version of this oil line diagram is located on the manual CD.

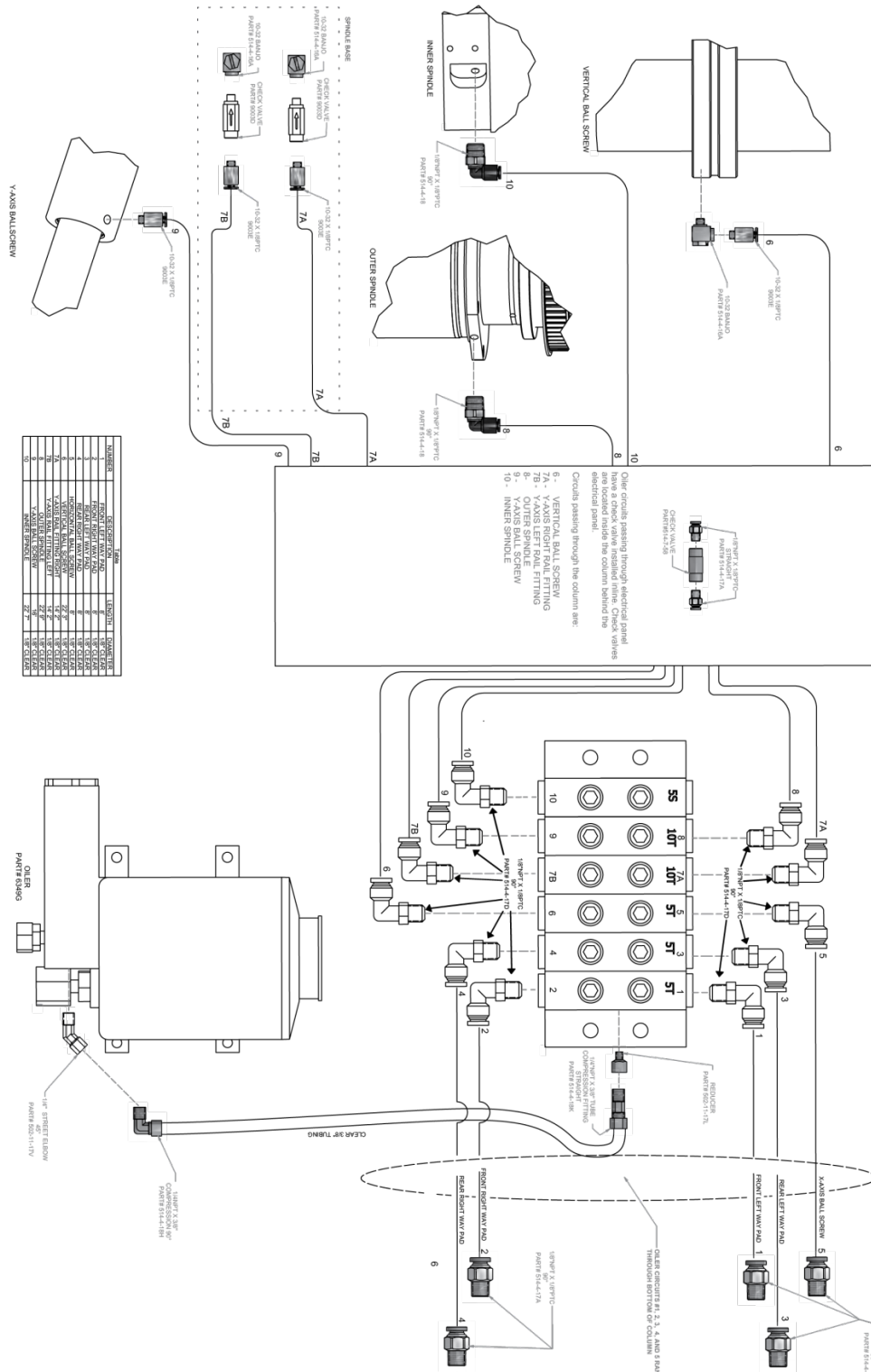

# OPTIONS

## Optional Equipment

Optional Equipment Catalog and Parts Manual are located on the Manual CD shipped with machine.



# MSDS

The Material Data Safety Sheets list shown in this section are the substances and materials that an operator is most likely to come in contact with while using this machine.

Other substances and materials are used in the manufacture, testing, and shipping of this machine. A complete list of the Material Data Safety Sheets of substances and materials used by Rottler Manufacturing during manufacturing, testing, and shipping is located on the Manual CD shipped with the machine. Material Data Safety Sheets are also located on the company web site: <http://www.rottlermfg.com/documentation.php>

## 1) Mobil Vactra Oil #2



Product Name: MOBIL VACTRA OIL NO. 2  
Revision Date: 17Oct2008  
Page 1 of 8

## MATERIAL SAFETY DATA SHEET

### SECTION 1 PRODUCT AND COMPANY IDENTIFICATION

#### PRODUCT

**Product Name:** MOBIL VACTRA OIL NO. 2  
**Product Description:** Base Oil and Additives  
**Product Code:** 600494-00, 970716  
**Intended Use:** Lubricant

#### COMPANY IDENTIFICATION

**Supplier:** EXXON MOBIL CORPORATION  
3225 GALLOWS RD.  
FAIRFAX, VA. 22037 USA

**24 Hour Health Emergency** 609-737-4411  
**Transportation Emergency Phone** 800-424-9300  
**ExxonMobil Transportation No.** 281-834-3296  
**Product Technical Information** 800-662-4525, 800-947-9147  
**MSDS Internet Address** <http://www.exxon.com>, <http://www.mobil.com>

### SECTION 2 COMPOSITION / INFORMATION ON INGREDIENTS

No Reportable Hazardous Substance(s) or Complex Substance(s).

### SECTION 3 HAZARDS IDENTIFICATION

This material is not considered to be hazardous according to regulatory guidelines (see (M)SDS Section 15).

#### POTENTIAL HEALTH EFFECTS

Low order of toxicity. Excessive exposure may result in eye, skin, or respiratory irritation. High-pressure injection under skin may cause serious damage.

<b>NFPA Hazard ID:</b>	Health: 0	Flammability: 1	Reactivity: 0
<b>HMIS Hazard ID:</b>	Health: 0	Flammability: 1	Reactivity: 0

**NOTE:** This material should not be used for any other purpose than the intended use in Section 1 without expert advice. Health studies have shown that chemical exposure may cause potential human health risks which may vary from person to person.

### SECTION 4 FIRST AID MEASURES

#### INHALATION

Remove from further exposure. For those providing assistance, avoid exposure to yourself or others. Use adequate respiratory protection. If respiratory irritation, dizziness, nausea, or unconsciousness occurs, seek immediate medical assistance. If breathing has stopped, assist ventilation with a mechanical device or use



Product Name: MOBIL VACTRA OIL NO. 2

Revision Date: 17Oct2008

Page 2 of 8

---

mouth-to-mouth resuscitation.

#### SKIN CONTACT

Wash contact areas with soap and water. If product is injected into or under the skin, or into any part of the body, regardless of the appearance of the wound or its size, the individual should be evaluated immediately by a physician as a surgical emergency. Even though initial symptoms from high pressure injection may be minimal or absent, early surgical treatment within the first few hours may significantly reduce the ultimate extent of injury.

#### EYE CONTACT

Flush thoroughly with water. If irritation occurs, get medical assistance.

#### INGESTION

First aid is normally not required. Seek medical attention if discomfort occurs.

### SECTION 5 FIRE FIGHTING MEASURES

#### EXTINGUISHING MEDIA

**Appropriate Extinguishing Media:** Use water fog, foam, dry chemical or carbon dioxide (CO<sub>2</sub>) to extinguish flames.

**Inappropriate Extinguishing Media:** Straight Streams of Water

#### FIRE FIGHTING

**Fire Fighting Instructions:** Evacuate area. Prevent runoff from fire control or dilution from entering streams, sewers, or drinking water supply. Firefighters should use standard protective equipment and in enclosed spaces, self-contained breathing apparatus (SCBA). Use water spray to cool fire exposed surfaces and to protect personnel.

**Hazardous Combustion Products:** Smoke, Fume, Aldehydes, Sulfur oxides, Incomplete combustion products, Oxides of carbon

#### FLAMMABILITY PROPERTIES

**Flash Point [Method]:** >205C (401F) [ASTM D-92]

**Flammable Limits (Approximate volume % in air):** LEL: 0.9 UEL: 7.0

**Autoignition Temperature:** N/D

### SECTION 6 ACCIDENTAL RELEASE MEASURES

#### NOTIFICATION PROCEDURES

In the event of a spill or accidental release, notify relevant authorities in accordance with all applicable regulations. US regulations require reporting releases of this material to the environment which exceed the applicable reportable quantity or oil spills which could reach any waterway including intermittent dry creeks. The National Response Center can be reached at (800)424-8802.

#### SPILL MANAGEMENT



Product Name: MOBIL VACTRA OIL NO. 2

Revision Date: 17Oct2008

Page 3 of 8

---

**Land Spill:** Stop leak if you can do it without risk. Recover by pumping or with suitable absorbent.

**Water Spill:** Stop leak if you can do it without risk. Confine the spill immediately with booms. Warn other shipping. Remove from the surface by skimming or with suitable absorbents. Seek the advice of a specialist before using dispersants.

Water spill and land spill recommendations are based on the most likely spill scenario for this material; however, geographic conditions, wind, temperature, (and in the case of a water spill) wave and current direction and speed may greatly influence the appropriate action to be taken. For this reason, local experts should be consulted. Note: Local regulations may prescribe or limit action to be taken.

#### ENVIRONMENTAL PRECAUTIONS

Large Spills: Dike far ahead of liquid spill for later recovery and disposal. Prevent entry into waterways, sewers, basements or confined areas.

### SECTION 7 HANDLING AND STORAGE

#### HANDLING

Prevent small spills and leakage to avoid slip hazard.

**Static Accumulator:** This material is a static accumulator.

#### STORAGE

Do not store in open or unlabelled containers. Keep away from incompatible materials.

### SECTION 8 EXPOSURE CONTROLS / PERSONAL PROTECTION

**Exposure limits/standards for materials that can be formed when handling this product:** When mists / aerosols can occur, the following are recommended: 5 mg/m<sup>3</sup> - ACGIH TLV, 10 mg/m<sup>3</sup> - ACGIH STEL, 5 mg/m<sup>3</sup> - OSHA PEL.

NOTE: Limits/standards shown for guidance only. Follow applicable regulations.

#### ENGINEERING CONTROLS

The level of protection and types of controls necessary will vary depending upon potential exposure conditions. Control measures to consider:

No special requirements under ordinary conditions of use and with adequate ventilation.

#### PERSONAL PROTECTION

Personal protective equipment selections vary based on potential exposure conditions such as applications, handling practices, concentration and ventilation. Information on the selection of protective equipment for use with this material, as provided below, is based upon intended, normal usage.

**Respiratory Protection:** If engineering controls do not maintain airborne contaminant concentrations at a level which is adequate to protect worker health, an approved respirator may be appropriate. Respirator



Product Name: MOBIL VACTRA OIL NO. 2

Revision Date: 17Oct2008

Page 4 of 8

selection, use, and maintenance must be in accordance with regulatory requirements, if applicable. Types of respirators to be considered for this material include:

No special requirements under ordinary conditions of use and with adequate ventilation.

For high airborne concentrations, use an approved supplied-air respirator, operated in positive pressure mode. Supplied air respirators with an escape bottle may be appropriate when oxygen levels are inadequate, gas/vapor warning properties are poor, or if air purifying filter capacity/rating may be exceeded.

**Hand Protection:** Any specific glove information provided is based on published literature and glove manufacturer data. Glove suitability and breakthrough time will differ depending on the specific use conditions. Contact the glove manufacturer for specific advice on glove selection and breakthrough times for your use conditions. Inspect and replace worn or damaged gloves. The types of gloves to be considered for this material include:

No protection is ordinarily required under normal conditions of use.

**Eye Protection:** If contact is likely, safety glasses with side shields are recommended.

**Skin and Body Protection:** Any specific clothing information provided is based on published literature or manufacturer data. The types of clothing to be considered for this material include:

No skin protection is ordinarily required under normal conditions of use. In accordance with good industrial hygiene practices, precautions should be taken to avoid skin contact.

**Specific Hygiene Measures:** Always observe good personal hygiene measures, such as washing after handling the material and before eating, drinking, and/or smoking. Routinely wash work clothing and protective equipment to remove contaminants. Discard contaminated clothing and footwear that cannot be cleaned. Practice good housekeeping.

#### ENVIRONMENTAL CONTROLS

See Sections 6, 7, 12, 13.

### SECTION 9 PHYSICAL AND CHEMICAL PROPERTIES

Typical physical and chemical properties are given below. Consult the Supplier in Section 1 for additional data.

#### GENERAL INFORMATION

**Physical State:** Liquid

**Color:** Brown

**Odor:** Characteristic

**Odor Threshold:** N/D

#### IMPORTANT HEALTH, SAFETY, AND ENVIRONMENTAL INFORMATION

**Relative Density (at 15 C):** 0.883

**Flash Point [Method]:** >205C (401F) [ASTM D-92]

**Flammable Limits (Approximate volume % in air):** LEL: 0.9 UEL: 7.0

**Autoignition Temperature:** N/D

**Boiling Point / Range:** N/D

**Vapor Density (Air = 1):** > 2 at 101 kPa

**Vapor Pressure:** < 0.013 kPa (0.1 mm Hg) at 20 C

**Evaporation Rate (n-butyl acetate = 1):** N/D

**pH:** N/A





Product Name: MOBIL VACTRA OIL NO. 2

Revision Date: 17Oct2008

Page 5 of 8

**Log Pow (n-Octanol/Water Partition Coefficient):** > 3.5  
**Solubility in Water:** Negligible  
**Viscosity:** 68 cSt (68 mm<sup>2</sup>/sec) at 40 C | 8.6 cSt (8.6 mm<sup>2</sup>/sec) at 100C  
**Oxidizing Properties:** See Sections 3, 15, 16.

#### OTHER INFORMATION

**Freezing Point:** N/D  
**Melting Point:** N/A  
**Pour Point:** -6°C (21°F)  
**DMSO Extract (mineral oil only), IP-346:** < 3 %wt

### SECTION 10 STABILITY AND REACTIVITY

**STABILITY:** Material is stable under normal conditions.

**CONDITIONS TO AVOID:** Excessive heat. High energy sources of ignition.

**MATERIALS TO AVOID:** Strong oxidizers

**HAZARDOUS DECOMPOSITION PRODUCTS:** Material does not decompose at ambient temperatures.

**HAZARDOUS POLYMERIZATION:** Will not occur.

### SECTION 11 TOXICOLOGICAL INFORMATION

#### ACUTE TOXICITY

Route of Exposure	Conclusion / Remarks
<b>Inhalation</b>	
Toxicity (Rat): LC50 > 5000 mg/m <sup>3</sup>	Minimally Toxic. Based on test data for structurally similar materials.
Irritation: No end point data.	Negligible hazard at ambient/normal handling temperatures. Based on assessment of the components.
<b>Ingestion</b>	
Toxicity (Rat): LD50 > 5000 mg/kg	Minimally Toxic. Based on test data for structurally similar materials.
<b>Skin</b>	
Toxicity (Rabbit): LD50 > 5000 mg/kg	Minimally Toxic. Based on test data for structurally similar materials.
Irritation (Rabbit): Data available.	Negligible irritation to skin at ambient temperatures. Based on test data for structurally similar materials.
<b>Eye</b>	
Irritation (Rabbit): Data available.	May cause mild, short-lasting discomfort to eyes. Based on test data for structurally similar materials.

#### CHRONIC/OTHER EFFECTS

##### Contains:

Base oil severely refined: Not carcinogenic in animal studies. Representative material passes IP-346, Modified Ames test, and/or other screening tests. Dermal and inhalation studies showed minimal effects; lung non-specific infiltration of immune cells, oil deposition and minimal granuloma formation. Not sensitizing in test animals.



Product Name: MOBIL VACTRA OIL NO. 2  
Revision Date: 17Oct2008  
Page 6 of 8

Additional information is available by request.

The following ingredients are cited on the lists below: None.

--REGULATORY LISTS SEARCHED--  
1 = NTP CARC                      3 = IARC 1                      5 = IARC 2B  
2 = NTP SUS                      4 = IARC 2A                      6 = OSHA CARC

## SECTION 12 ECOLOGICAL INFORMATION

The information given is based on data available for the material, the components of the material, and similar materials.

### ECOTOXICITY

Material -- Not expected to be harmful to aquatic organisms.

### MOBILITY

Base oil component -- Low solubility and floats and is expected to migrate from water to the land. Expected to partition to sediment and wastewater solids.

### PERSISTENCE AND DEGRADABILITY

#### Biodegradation:

Base oil component -- Expected to be inherently biodegradable

### BIOACCUMULATION POTENTIAL

Base oil component -- Has the potential to bioaccumulate, however metabolism or physical properties may reduce the bioconcentration or limit bioavailability.

## SECTION 13 DISPOSAL CONSIDERATIONS

Disposal recommendations based on material as supplied. Disposal must be in accordance with current applicable laws and regulations, and material characteristics at time of disposal.

### DISPOSAL RECOMMENDATIONS

Product is suitable for burning in an enclosed controlled burner for fuel value or disposal by supervised incineration at very high temperatures to prevent formation of undesirable combustion products.

### REGULATORY DISPOSAL INFORMATION

RCRA Information: The unused product, in our opinion, is not specifically listed by the EPA as a hazardous waste (40 CFR, Part 261D), nor is it formulated to contain materials which are listed as hazardous wastes. It does not exhibit the hazardous characteristics of ignitability, corrosivity or reactivity and is not formulated with contaminants as determined by the Toxicity Characteristic Leaching Procedure (TCLP). However, used product may be regulated.

**Empty Container Warning** Empty Container Warning (where applicable): Empty containers may contain residue and can be dangerous. Do not attempt to refill or clean containers without proper instructions. Empty drums should be



Product Name: MOBIL VACTRA OIL NO. 2

Revision Date: 17Oct2008

Page 7 of 8

completely drained and safely stored until appropriately reconditioned or disposed. Empty containers should be taken for recycling, recovery, or disposal through suitably qualified or licensed contractor and in accordance with governmental regulations. DO NOT PRESSURISE, CUT, WELD, BRAZE, SOLDER, DRILL, GRIND, OR EXPOSE SUCH CONTAINERS TO HEAT, FLAME, SPARKS, STATIC ELECTRICITY, OR OTHER SOURCES OF IGNITION. THEY MAY EXPLODE AND CAUSE INJURY OR DEATH.

<b>SECTION 14</b>	<b>TRANSPORT INFORMATION</b>
-------------------	------------------------------

**LAND (DOT)** : Not Regulated for Land Transport

**LAND (TDG)** : Not Regulated for Land Transport

**SEA (IMDG)** : Not Regulated for Sea Transport according to IMDG-Code

**AIR (IATA)** : Not Regulated for Air Transport

<b>SECTION 15</b>	<b>REGULATORY INFORMATION</b>
-------------------	-------------------------------

**OSHA HAZARD COMMUNICATION STANDARD:** When used for its intended purposes, this material is not classified as hazardous in accordance with OSHA 29 CFR 1910.1200.

**NATIONAL CHEMICAL INVENTORY LISTING:** AICS, IECSC, DSL, EINECS, ENCS, KECI, PICCS, TSCA

**EPCRA:** This material contains no extremely hazardous substances.

**SARA (311/312) REPORTABLE HAZARD CATEGORIES:** None.

**SARA (313) TOXIC RELEASE INVENTORY:** This material contains no chemicals subject to the supplier notification requirements of the SARA 313 Toxic Release Program.

**The Following Ingredients are Cited on the Lists Below:** None.

--REGULATORY LISTS SEARCHED--

1 = ACGIH ALL	6 = TSCA 5a2	11 = CA P65 REPRO	16 = MN RTK
2 = ACGIH A1	7 = TSCA 5e	12 = CA RTK	17 = NJ RTK
3 = ACGIH A2	8 = TSCA 6	13 = IL RTK	18 = PA RTK
4 = OSHA Z	9 = TSCA 12b	14 = LA RTK	19 = RI RTK
5 = TSCA 4	10 = CA P65 CARC	15 = MI 293	

Code key: CARC=Carcinogen; REPRO=Reproductive

<b>SECTION 16</b>	<b>OTHER INFORMATION</b>
-------------------	--------------------------

N/D = Not determined, N/A = Not applicable

**THIS SAFETY DATA SHEET CONTAINS THE FOLLOWING REVISIONS:**



Product Name: MOBIL VACTRA OIL NO. 2

Revision Date: 17Oct2008

Page 8 of 8

---

No revision information is available.

---

The information and recommendations contained herein are, to the best of ExxonMobil's knowledge and belief, accurate and reliable as of the date issued. You can contact ExxonMobil to insure that this document is the most current available from ExxonMobil. The information and recommendations are offered for the user's consideration and examination. It is the user's responsibility to satisfy itself that the product is suitable for the intended use. If buyer repackages this product, it is the user's responsibility to insure proper health, safety and other necessary information is included with and/or on the container. Appropriate warnings and safe-handling procedures should be provided to handlers and users. Alteration of this document is strictly prohibited. Except to the extent required by law, re-publication or retransmission of this document, in whole or in part, is not permitted. The term, "ExxonMobil" is used for convenience, and may include any one or more of ExxonMobil Chemical Company, Exxon Mobil Corporation, or any affiliates in which they directly or indirectly hold any interest.

---

Internal Use Only

MHC: 0B, 0B, 0, 0, 0, 0

PPEC: A

DGN: 2007221XUS (1014962)

---

Copyright 2002 Exxon Mobil Corporation, All rights reserved