

**ROTTLER**

**H75 CNC HONE  
OPERATION AND  
MAINTENANCE MANUAL**





# MANUAL SECTIONS

INTRODUCTION

INSTALLATION

SAFETY

CONTROL DEFINITIONS

OPERATING INSTRUCTIONS

MAINTENANCE

TROUBLESHOOTING

MACHINE PARTS

OPTIONS

MSDS

## ORDERING PROCEDURE

Contact your regional Rottler sales rep for assistance in ordering optional equipment, replacement parts, or tooling.

If you are unable to contact your regional Rottler sales rep, call the factory at 253-872-7050 and ask to speak to the parts sales specialist.

Have the following information handy to expedite the ordering process:

1. Your name, business name, and contact number
2. Customer number
3. If you don't have a customer number, your billing address
4. Shipping address if different from billing address
5. Machine model and serial number
6. Part number and description of what you want to order
7. Preferred method of shipment
8. You may also contact us via e-mail with the above information. Send e-mail requests to:  
[parts@rottlermfg.com](mailto:parts@rottlermfg.com)

In some cases you may be requested to send a photo of the part you are ordering if it is a replacement part, or doesn't appear in the database.

If you are unsure which part you need to order, contact our service department and ask to speak to one of our service consultants. They will assist you in determining which part you require.

**THERE IS A MINIMUM ORDER OF \$25.00**



# INTRODUCTION

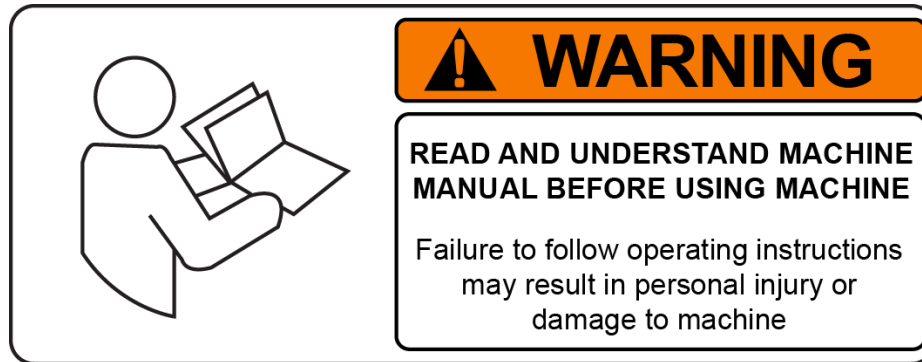

**READ THE SAFETY CHAPTER BEFORE INSTALLING MACHINE. THOROUGHLY UNDERSTAND ALL SAFETY ISSUES BEFORE OPERATING MACHINE.**

## ***ATTENTION OWNER/BUSINESS MANAGER***

**To validate the warranty on your new Rottler machine, please be sure to sign and complete the “Installation Report” located in the Installation Chapter of this manual.**

We suggest that the new user of the H75X read the CONTROL DEFINITIONS to get an idea how the machine operates.

The Operating Instructions chapter should be read in order to familiarize the user with the actual button pushing sequences required to carry out a job. These chapters in the manual should be considered an introduction. As the operators of the H75X series machines gain experience with using the different functions of the machine, complicated setups and programs will make more sense.

The rest of the manual contains information and part number reference on fixtures, cutting tools, and machine maintenance. The operator should read and become familiar with these areas as well.

### **Description**

The model H75X Honing Machine is a wet, complete cylinder block and general purpose-honing machine

A Windows based touch screen panel provides easy and convenient control of the H75X. Block programs can be created and stored to memory for later recall, providing a quick set up for honing common blocks. All preferences such as dwell setting, cross hatch angle, and honing loads are automatically set up when a block program is selected at time of machine set-up.

The support carriage is mounted on linear rails and is powered by a direct drive motor driving a ballscrew assembly to provide simple and easy hole-to-hole setup.

Convenient devices are provided to properly control honing operations and provide easy handling.

Fixtures are available for doing a large variety of engine types. Special fixtures and tooling for doing large industrial engine sleeves is also available.

A splash tank is located within the main frame and a coolant pump tank is located behind the machine. A button is provided on the control panel to operate the coolant system.

### **Disclaimer**

The H75X Manual (henceforth to be referred to as the "Manual") is proprietary to Rottler Manufacturing LLC. ("Rottler Manufacturing") and no ownership rights are hereby transferred. No part of the Manual shall be used, reproduced, translated, converted, adapted, stored in a retrieval system, communicated or transmitted by any means, for any commercial purpose, including without limitation, sale, resale, license, rental or lease, without the prior express written consent of Rottler Manufacturing.

Rottler Manufacturing does not make any representations, warranties or guarantees, express or implied, as to the accuracy or completeness of the Manual. Users must be aware that updates and amendments will be made from time to time to the Manual. It is the user's responsibility to determine whether there have been any such updates or amendments. Neither Rottler Manufacturing nor any of its directors, officers, employees or agents shall not be liable in any manner whatsoever to any person for any loss, damage, injury, liability, cost or expense of any nature, including without limitation incidental, special, direct or consequential damages arising out of or in connection with the use of the Manual.

### **Limited Warranty**

Rottler Manufacturing Company Model H75X parts and equipment is warranted as to materials and workmanship. This limited warranty remains in effect for one year from the date of delivery, provided the machine is owned and operated by the original purchaser and is operated and maintained as per the instructions in the manual.

Tools proven to be defective within the warranty period will be repaired or replaced at the factory's option.

The products are warranted upon delivery to conform to their published specifications and to be free from defects in material and workmanship under normal use for a period of one year from shipment. Should a product not be as warranted, Rottler sole obligation shall be, at its option, to repair, correct or replace the product or to refund the amounts paid for the Product upon its return to a location designated by Rottler. No warranty shall extend to rapid wear Products (including tooling) or to Products which have been subject to misuse (including any use contrary to Rottler instructions), neglect, accident (including during shipment), improper handling or installation, or subject to any modification, repair or service not certified by Rottler. Rottler shall not be liable for any consequential, direct or indirect damages or for any other injury or loss. Buyer waives any right, beyond the foregoing warranty, to make a claim against Rottler. No warranty is provided for any Products not paid in full.

Merchandise cannot be returned to Rottler without prior approval. Customer must contact the Order Department or representative to get approval and to be issued a Return Goods Authorization number (RGR#). Merchandise authorized for return must be returned prepaid. If merchandise is returned with shipping charges collect, the actual amount of these charges may be deducted from any credit which may be due the customer. The RGR # assigned by the Order Department should be written on the shipping label and must appear on a copy of the invoice(s) covering the original shipment. This invoice copy must be included in the box with the parts. Shipment must contain ONLY those items on the RGR as approved for return. Merchandise must be received within 10 days of the date of RGR or the RGR will

be canceled. All returned merchandise may be subject to a 20% restocking fee on under \$1,000.00 amount or 10% on any items over \$1,000.00. Parts or tooling over 30 days old are considered as customer property and can only be returned with prior written approval from Rottler Corporation Management and/ or Shipping Department.

The issuance of a **RGR DOES NOT** guarantee credit - it is only authorization for the return of the goods. Credit for return merchandise is at the sole discretion of Rottler. Credit will be issued only after inspection of returned goods.

Tools proven to be defective within the warranty period will be repaired or replaced at the factory's option. We accept no responsibility for defects caused by external damage, wear, abuse, or misuse, nor do we accept any obligation to provide compensation for direct or indirect costs in connection with cases covered by the warranty.

This page intentionally left blank





# INSTALLATION

## Contents

**Installation Procedure .....2-7**

**Location ..... 2-7**

**Unpacking ..... 2-7**

**Leveling ..... 2-7**

**Coolant ..... 2-7**

**Power Supply ..... 2-8**

**Grounding .....2-9**

**Three Phase Electrical Hook-up ..... 2-10**

**Single Phase Electrical Hookup .....2-11**

# ATTENTION OWNER/BUSINESS MANAGER

To validate the warranty on your new Rottler machine, please be sure to sign the installation report after the installation technician has installed the machine and verified the machine is operating correctly and given the operators operation and maintenance training.

Thank you for your cooperation and the opportunity to be of service to you.

## ROTTLER MANUFACTURING

Route to: Service Mgr \_\_\_\_\_> Andy \_\_\_\_\_> Machine Packet File  
H75X Installation Report Rev 08202015

## ROTTLER H75X INSTALLATION REPORT

### ROTTLER MANUFACTURING MUST HAVE THIS REPORT RETURNED TO PROPERLY QUALIFY WARRANTY ON EQUIPMENT

Customer: \_\_\_\_\_

Address: \_\_\_\_\_ City: \_\_\_\_\_

State: \_\_\_\_\_ Zip: \_\_\_\_\_ Phone: \_\_\_\_\_ Machine Model: \_\_\_\_\_ Serial

Number: \_\_\_\_\_ Representative: \_\_\_\_\_ **MACHINE INSTALLATION:** Electrical

information MUST be complete to validate this report.

**Customer responsibility prior to the arrival of Rottler Sales/Service technician. Please Initial each item when it is completed.**



**VERY IMPORTANT:** Modern design machines contain electronic low voltage circuitry that provides great advantages and a better machine life. **BUT**, you must have an excellent, stable, isolated power supply along with an isolated ground. If not, electrical noise problems are likely to interfere with machine operation unexpectedly.

Customer is responsible for providing electricity to machine in a manner that meets the local electrical code requirements.

\_\_\_\_\_ Remove machine from truck. Weight: 2,500 lbs.

- \_\_\_\_\_ Provide solid foundation for machine.
- \_\_\_\_\_ Remove fixturing and misc. from machine and clean.
- \_\_\_\_\_ Install machine on foundation with jack pads under jacking bolts.
- \_\_\_\_\_ Level machine. When level all leveling bolts should have equal pressure on them.
- \_\_\_\_\_ This machine requires between 208 and 240 Volts AC, Three Phase, 50/60 Hz, **isolated** power supply.

**IMPORTANT** If this machine is being installed in a location without 3 phase power, follow the single phase wiring hookup shown in this section

\_\_\_\_\_ Measure the incoming voltage between L1 and L2, L2 and L3, L1 and L3. Measure the incoming AC voltage at least **twice** during installation.

L1 to L2 \_\_\_\_\_ VAC    L2 to L3 \_\_\_\_\_ VAC    L1 to L3 \_\_\_\_\_ VAC  
 L1 to L2 \_\_\_\_\_ VAC    L2 to L3 \_\_\_\_\_ VAC    L1 to L3 \_\_\_\_\_ VAC

- \_\_\_\_\_ This machine should have an external breaker rated at 30 Amps, continuous draw.
- \_\_\_\_\_ Measure each leg of the incoming supply to ground. Sometimes you may find a “high” leg to ground. When this happens make sure the high leg is running to L3. This line goes to the spindle drive only.

L1 to ground \_\_\_\_\_ VAC    L2 to ground \_\_\_\_\_ VAC    L3 to ground \_\_\_\_\_ VAC

**CAUTION** Neutral and machine ground are not the same thing. You should measure an open circuit between Neutral and ground.

**CAUTION** IF VOLTAGE IS OUTSIDE THE CORRECT RANGE AT ANY TIME THE MACHINE WILL NOT OPERATE PROPERLY AND MAY BE DAMAGED.

\_\_\_\_\_ Briefly describe the isolated ground connection to the machine you have made: (Instructions to make a correct isolated ground are included in the operating manual)

---



---



---

- \_\_\_\_\_ Customer should attempt to have junk work piece available.
- \_\_\_\_\_ Make sure coolant will be available for set up.
- \_\_\_\_\_ Have the operator read through the operation manual before training begins. This will help him be familiar with the button pushing sequences. Have the operator read through the manual again after training and some of the sequences will make more sense.
- \_\_\_\_\_ Clean any rust inhibitor from the machine surfaces
- \_\_\_\_\_ Make sure that an Internet connection is available at the machine.

**The following is the Rottler Sales/Service technician’s responsibility**

**MACHINE START-UP**

- \_\_\_\_\_ **BEFORE** turning power on to the machine. Check all wires for security by using the correct screw driver and turning CW until movement stops. Stranded wire can “spread” slightly from vibration during transport.
- \_\_\_\_\_ The system is protected by fuses and circuit breakers located in the electrical enclosure. Show customer where they are located and confirm that spare fuses were shipped with machine.

**CAUTION** When starting the machine for the first time, it may move out of control. Make sure all hands are clear of machine parts. Be ready to press the Emergency Stop button if needed.

- \_\_\_\_\_ Explain the coolant filtration system and necessity of maintenance to that system.
- \_\_\_\_\_ Explain to the customer the injection oiler operation. The timer is controlled by the computer. Show the customer where the reservoir is located and explain what type of oil is required.
- \_\_\_\_\_ Turn Main power on at the power switch located on the electrical enclosure.
- \_\_\_\_\_ If any of the fuses blow, replace them, then call factory if further assistance is needed.
- \_\_\_\_\_ If any of the circuit breakers “trip”, reset and call factory for possible trouble shooting.
- \_\_\_\_\_ If machine moves out of control, turn power off and contact factory for help in trouble shooting.
- \_\_\_\_\_ Install and test the Internet connection to the machine. DO NOT download any updates unless instructed to do so by Rottler.

## MACHINE MOVEMENTS

- \_\_\_\_\_ Remove hone head from machine for the following procedures.
- \_\_\_\_\_ Verify all machine movements are working correctly using the hand wheel.
- \_\_\_\_\_ Verify all machine movements are working correctly using the jog buttons.
- \_\_\_\_\_ Start spindle motor to verify correct direction of rotation.

## INSTRUCTING THE OPERATOR:

### **WARNING**

- \_\_\_\_\_ Explain to the customer and operator that at NO time is there to be any software or hardware other than Windows Auto Update and Rottler installed on this machine. This includes screen savers, anti-virus software, and any hardware device that installs software on the machine. Installation of screen savers and anti-virus software can cause dangerous control problems. Any installation of software or hardware will void the warranty on the machine.
- \_\_\_\_\_ Explain to the customer and operator that the machine should be hooked up to the Internet anytime it is on. The software on the machine will automatically connect to our server to send back useful information on machine status.
- \_\_\_\_\_ Explain to the customer and operator that the Auto Update for the Windows Firewall (Security) and Windows Defender (Anti-Virus) is turned on. The computer will automatically download the updates and then install them when the computer is shut down every Friday night.
- \_\_\_\_\_ Explain to the customer and the operator how the to log onto Skype and communicate with Rottler when needed.

### **WARNING**

- \_\_\_\_\_ Computer Viruses will cause the machine control system to become unstable. This may cause the machine to make uncontrolled moves which could create a dangerous environment for the machine operator.
- \_\_\_\_\_ Connect customer supplied Internet to the machine. Verify that the Internet is accessible from the machine.

### **IMPORTANT**

- \_\_\_\_\_ Refer to Chapter 4, Control Definitions of the Machine Manual, Section: Computer and Controller System Safety. Explain and discuss this section carefully with Owner/Manager/Operator and have them sign off. Failure to do so will result in the machine warranty being Null and Void.

---

Signature / Title

- \_\_\_\_\_ Using the operating manual as a guide explain the function of all buttons.
- \_\_\_\_\_ Cycle all machine movements and supervise the handling of same by operator.
- \_\_\_\_\_ Demonstrate the differences of Manual and Auto operation.

- \_\_\_\_\_ If equipped with the auto rotate fixture explain how to set up and operate.
- \_\_\_\_\_ Explain selecting correct riser blocks for the block to be honed.
- \_\_\_\_\_ Fully explain the entire Auto Cycle.
- \_\_\_\_\_ Explain the need to Home the machine each time the hone head is changed or removed and reinstalled on the spindle.
- \_\_\_\_\_ Point out safety features to customer and operator. Do not push any buttons without thinking of safety first.
- \_\_\_\_\_ Explain to the customer the proper way to turn the machine off when it is not in use. Do not leave the machine on overnight. It is important to close all programs followed by shutting down Windows before turning the main power switch off. Do not turn the main power switch off before shutting down Windows.
- \_\_\_\_\_ The following is a checklist of information needed prior to setting up a job.
- Finish bore size, cross hatch angle, and finish.
  - Bore length.
  - Center to center dimension of cylinders.
  - If the job is a V type block, the pan rail to crank line center dimension, and cylinder offset between cylinder banks.
- \_\_\_\_\_ Demonstrate loading and roll over of V8 block.
- \_\_\_\_\_ Demonstrate in-line block clamp system.
- \_\_\_\_\_ Explain Optional block hold down arrangements.
- \_\_\_\_\_ Supervise the operator loading, cycling and unloading the block.
- \_\_\_\_\_ Develop the best block handling system you can for his shop.
- \_\_\_\_\_ Consider a block coolant drain area.
- \_\_\_\_\_ Examine several V8 blocks at the lower cylinder / bearing cap area and explain to the operator the necessity of setting the lower stop for maximum over stroke.
- \_\_\_\_\_ Explain the ABSOLUTE requirement for complete relief below the cylinder, which may include hand grinding.
- \_\_\_\_\_ Demonstrate removal and cleaning of cone in hone head.
- \_\_\_\_\_ Explain all stone options as well as hone head options.
- \_\_\_\_\_ Explain to the operator the methods for the fastest stock removal.
- \_\_\_\_\_ Explain the cause and cure of bad geometry and improper stone cutting.
- \_\_\_\_\_ Explain "breaking" the stones in.
- \_\_\_\_\_ Demonstrate proper stone dressing (refer to manual).
- \_\_\_\_\_ Explain the importance of maintaining the proper coolant mix.
- \_\_\_\_\_ Explain the importance of keeping the coolant clean.
- \_\_\_\_\_ Review the necessity of proper stone to coolant relationship.
- \_\_\_\_\_ Again review the operator manual, including all safety and emergency stop procedures.

## MAINTENANCE SECTION

- \_\_\_\_\_ Review machine Lubrication per manual.
- \_\_\_\_\_ Review coolant changing.
- \_\_\_\_\_ Review filter paper changing.
- \_\_\_\_\_ Review filling oil reservoir.

General remarks on machine performance, adjustments as received and any further organization or parts required to complete the set up:

---

---

---

---

---

---

---

---

---

---

---

---

---

---

---

---

---

---

---

---

---

Instructions given to: \_\_\_\_\_

Sales/Service Engineer: \_\_\_\_\_ Date \_\_\_\_\_

Shop Foreman/Superintendent or Owner: \_\_\_\_\_ Date \_\_\_\_\_

**Installation Procedure**

**Location**

The productivity of this machine will depend to a great extent on its proper initial installation, particularly the means by which cylinder blocks are lifted into the machine as well as the material handling to and from other operations in your shop.

The proper loading arrangement and location for your H75X machine is extremely important.

A slow travel (6' to 10' per min.) power hoist, operated from either a bridge crane or a jib crane arrangement works very well. A 1000-lb. hoist is generally adequate for lifting the engine block. An air hoist with speed control makes an ideal method for fast, convenient loading.

If some production honing with this machine is anticipated, and the cylinder blocks are not directly loaded and unloaded from a conveyor, we would recommend considerable attention be given to the crane so that it covers an adequate area to allow the operator to back up and remove cylinder blocks without cluttering up his own area. If two machines are to be operated by one operator, we recommend that the open faces be placed at right angles to each other, with the machines approximately three feet apart.

## Unpacking

Carefully uncrate the H75X Machine. Remove all equipment in splash tank.

Completely clean the machine exposed metal surfaces with solvent. Rust inhibitor is applied to the machine at the time of shipment and must be removed before operating the machine.

## Leveling

Four cap screws and jam nuts are provided with the machine for leveling. Insert the screws from the bottom of the base. Place the jam nuts on top of the threaded hole in the base.

Using a precision level, level the upper table within .002" per foot in both directions (Except favor the high setting to the front for best coolant return).

## Coolant



Refer to the Coolant section in Chapter 5 of this manual for proper coolant types and mixes. Be sure to read the MSDS section of this manual and exercise due caution concerning coolant hazard.

## Power Supply



***Disconnect all power before servicing this machine. Failure to do so could result in electrical shock.***

This machine has the following power requirements:

208 to 240 VAC



Three Phase

50 or 60 Hertz

30 amps

(See wiring diagram for the H75X Hone).

See illustration following for correct connection of “measured” incoming power

***Electrically connect in accordance with national and local electrical codes.*****Note: This machine requires the use of an electrical disconnect switch.**

This machine cannot be run on 440 volts. A transformer must be installed if 440 volts must be used.

**Grounding**

This machine must be connected to a good earth ground rod. A 6 foot, 1/2” diameter, 15 OHM, Copper grounding rod driven into the earth next to the machines is preferred. Not providing a grounding rod could void factory warranty.

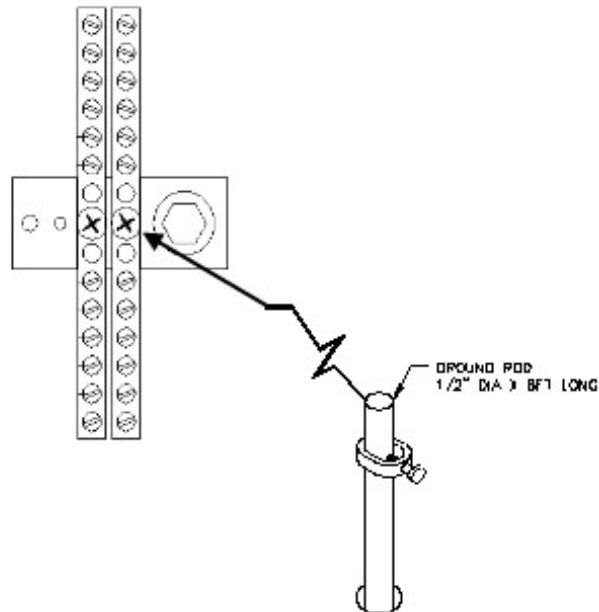

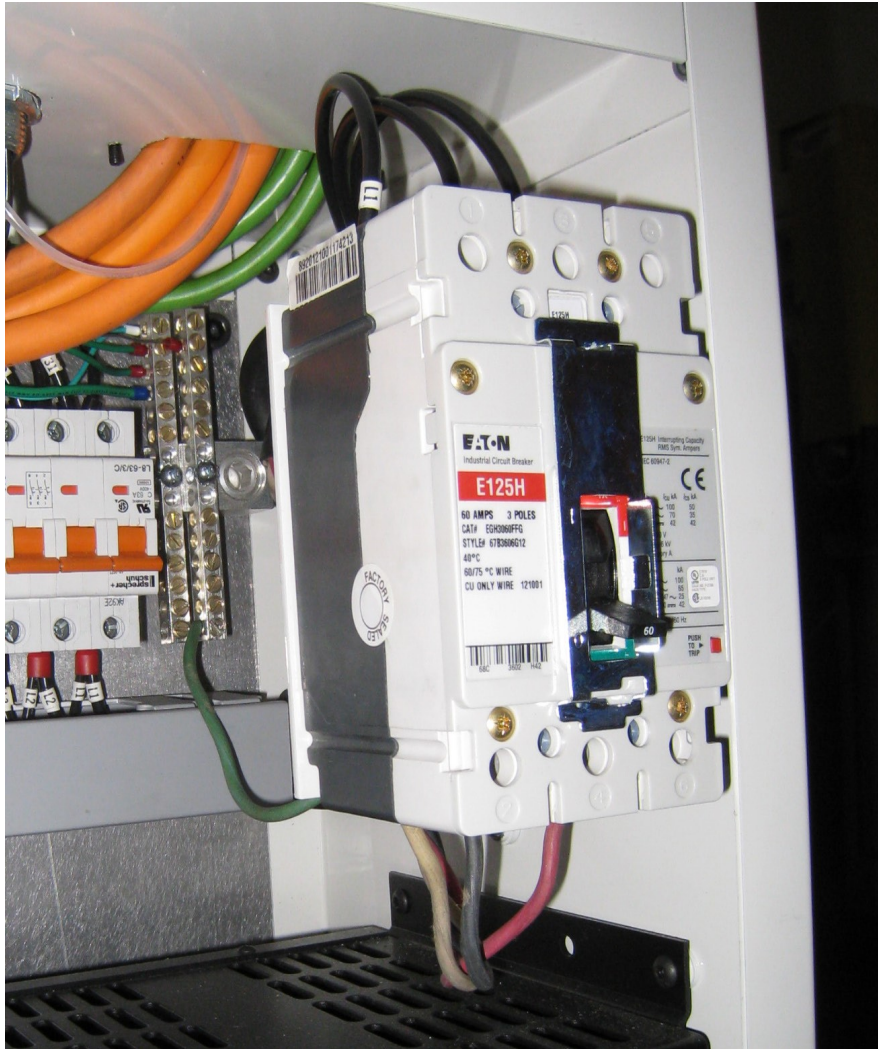
**Three Phase Electrical Hook-up**

L1, L2, and L3 incoming lines are attached to the power switch. Incoming supply ground wire goes to the ground block.

See electrical diagram for more detail.

**CAUTION**

Wire in accordance with local and national codes.

**Single Phase Electrical Hookup**

Not recommended due to 30% loss in power.

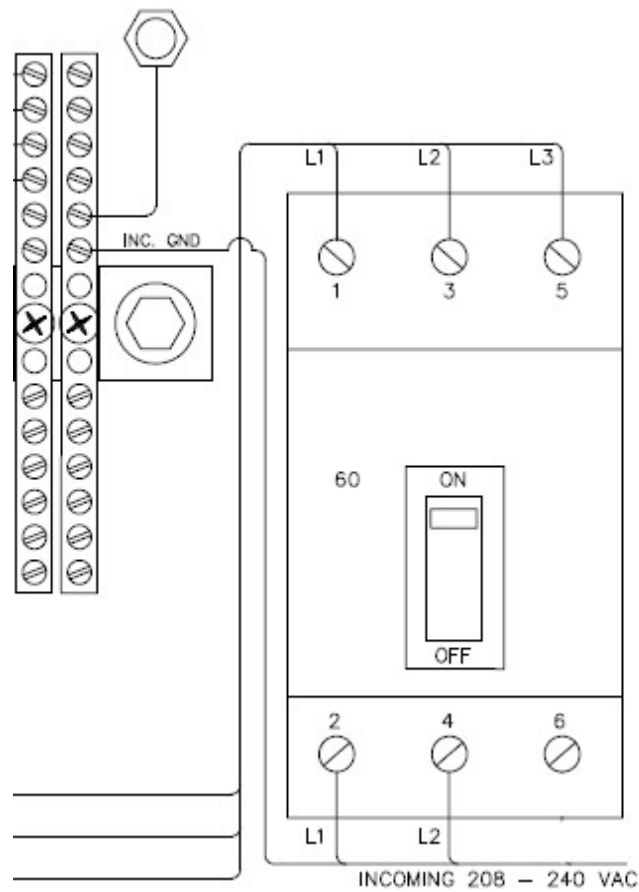

L1 and L2 incoming lines are attached to the power switch. Incoming supply ground wire goes to the ground block.

**CAUTION**

Wire in accordance with local and national codes.

# SAFETY

## Contents

<b>Safety Information .....</b>	<b>31</b>
<b>Safety Instructions for Machine Use .....</b>	<b>3 1</b>
<b>Electrical Power .....</b>	<b>33</b>
<b>Machine Operator .....</b>	<b>33</b>
<b>Computer and Controller System Safety .....</b>	<b>3 6</b>
<b>Electrical Safety Features Of Rottler DM Controlled Machines .....</b>	<b>3 6</b>

## Safety Information

For Your Own Safety Read This Instruction Manual Before Operating This Machine.

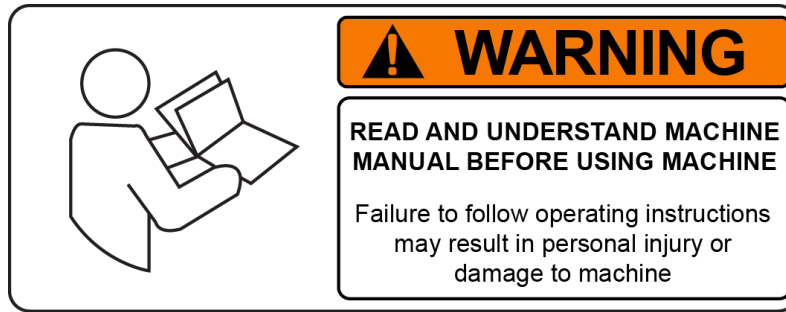

This is the safety alert symbol. It is used to alert you to potential personal injury hazards. Obey all safety messages that follow this symbol to avoid possible injury or death.



**DANGER** indicates an imminently hazardous situation which, if not avoided, will result in death or serious injury.



**WARNING** indicates a potentially hazardous situation which, if not avoided, could result in death or serious injury.



**CAUTION** indicates a potentially hazardous situation which, if not avoided, may result in minor or moderate injury.



**CAUTION** used without the safety alert symbol indicates a potentially hazardous situation which, if not avoided, may result in property damage.

### Safety Instructions for Machine Use



This machine is capable of causing severe bodily injury

**ONLY A QUALIFIED, EXPERIENCED OPERATOR SHOULD OPERATE THIS MACHINE. NEVER ALLOW UNSUPERVISED OR UNTRAINED PERSONNEL TO OPERATE THE MACHINE.** Make sure any instructions you give in regards to machine operation are approved, correct, safe, and clearly understood. Untrained personnel present a hazard to themselves and the machine. Improper operation will void the warranty.

**KEEP GUARDS IN PLACE** and in proper working order. If equipped with doors, they must be in the closed position when the machine is in operation.



**KEEP WORK AREA CLEAN.** Cluttered areas and benches invite accidents.

**KEEP WORK AREA CLEAN.** Clean spilled coolant from floor to avoid slipping hazard.

**KEEP CHILDREN AND VISITORS AWAY.** All children and visitors should be kept a safe distance from work area.

**WEAR THE PROPER APPAREL.** **DO NOT** wear loose clothing, gloves, rings, bracelets, or other jewelry which may get caught in moving parts. Non-Slip foot wear is recommended. Wear protective hair covering to contain long hair.



**ALWAYS USE SAFETY GLASSES** Everyday eye glasses only have impact resistant lenses, they are NOT safety glasses.

**DO NOT OVER-REACH.** Keep proper footing and balance at all times.

**USE THE RECOMMENDED ACCESSORIES.** Consult the manual for recommended accessories. The use of improper accessories may cause risk of injury.

**CHECK DAMAGED PARTS.** Before further use of the machine, a guard or other part that is damaged should be checked to determine that it will operate properly and perform its intended function. Check for alignment of moving parts, breakage of parts, mounting, and other conditions that may affect its operation. A guard or other part that is damaged should be properly repaired or replaced.

**NEVER OPERATE A MACHINE WHEN TIRED, OR UNDER THE INFLUENCE OF DRUGS OR ALCOHOL.** Full mental alertness is required at all times when running a machine.

**NEVER ALLOW UNSUPERVISED OR UNTRAINED PERSONNEL TO OPERATE THE MACHINE.** Make sure any instructions you give in regards to machine operation are approved, correct, safe, and clearly understood.

**IF AT ANY TIME YOU ARE EXPERIENCING DIFFICULTIES** performing the intended operation, stop using the machine! Then contact our service department or ask a qualified expert how the operation should be performed.

**CAUTION**

*No list of safety guidelines can be complete. Every shop environment is different. Always consider safety first, as it applies to your individual working conditions. Use this and other machinery with caution and respect. Failure to follow guidelines*

*could result in serious personal injury, damage to equipment or poor work results.*



***All electrical power should be removed from the machine before opening the rear electrical enclosure. It is recommended that the machine have a electrical LOCK-OUT device installed.***

Make sure all electrical equipment has the proper electrical overload protection.

In the event of an electrical short, grounding reduces the risk of electric shock by providing a path of least resistance to disperse electric current.



***Electrocution or a fire can result if the machine is not grounded correctly. Make sure the ground is connected in accordance with this manual. DO NOT operate the machine if it is not grounded.***



***No single list of electrical guidelines can be comprehensive for all shop environments. Operating this machinery may require additional electrical***

***upgrades specific to your shop environment. It is your responsibility to make sure your electrical system comply with all local codes and ordinances.***

### **Machine Operator**

Operator of this H75X Honing machine should be a skilled machinist craftsman: that is well versed in the caution, care, and knowledge required to safely operating a metal cutting tool.

If the operator is not a skilled machinist, the operator must pay strict attention to the operating procedure outlined in this manual, and must get instruction from a qualified machinist in both the productive and safe operation of this H75X Honing Machine.

Rottler H75X Honing equipment has the following areas of exposed moving parts that you must train yourself to respect and stay away from when they are in motion:



Safety glasses are recommended while machine is running.



**Work Clamping** - Be sure work is clamped securely in accordance with the instructions.

**Hone Head Area** - Keep hands completely away from the rotating honing head at ALL times.

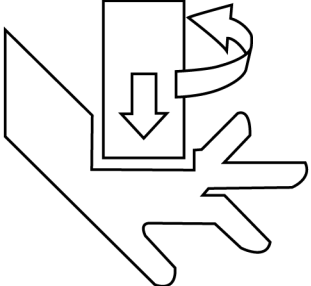

A diagram showing a hand reaching towards a rotating hone head. A downward arrow indicates the direction of the hone head's movement, and a curved arrow indicates its rotation.

**! DANGER**

**IMPACT AND ROTATION HAZARD**

KEEP HANDS CLEAR OF HONE HEAD WHEN MACHINE IS IN OPERATION

DO NOT GRAB HONE HEAD WHILE IT IS ROTATING OR IN MOTION

IMPROPER USE COULD RESULT IN SERIOUS INJURY OR DEATH

**Honing** - Do not engage rotation power when hone is out of a cylinder.



**Operator Controls** - Familiarize yourself with the exact location of the e-stop button so you can immediately react to an emergency.



*blocks or fixtures.*



A large black exclamation mark inside a black triangle.

**! DANGER**

**THIS MACHINE IS CAPABLE OF STARTING AND RUNNING AUTOMATICALLY**

*Keep clear of spindle when working in tank area. Spindle can drop if there is a failure in the machine. Move spindle out of work area when changing*



**IMPORTANT**

***Remember***

Machine tools have the speed and torque to severely injure any part of the human body exposed to them.

## Computer and Controller System Safety

The computer and controller are located in the main rear electrical enclosure. This unit is a full computer, running Windows 7 64 Bit operating system. Contact the factory if more information on the computer system is required.

**IMPORTANT:** The computer in this machine has the ability to connect to the World Wide Web via Ethernet or Wireless using a USB wireless (Wi-Fi) adapter. Updating the Rottler software should ONLY be done when directed to do so by a Rottler service technician. Updating Rottler Software when not directed by Rottler personnel will result in a non-operational machine.

The machine should be hooked up to the Internet anytime it is on. The software on the machine will automatically connect to our server to send back useful information on machine status.

The Auto Update for the Windows Firewall (Security) and Windows Defender (Anti-Virus) is turned on. The computer will automatically download the updates and then install them when the computer is shut down every Friday night.

**Any "IT" personnel should ALWAYS get approval from Rottler before doing ANYTHING on the computer.**



This machine is capable of causing severe injury or death. Doing any of the following without Rottler's direct consent may cause severe injury or death.



Do not attempt to install USB devices in the PLC ports. These ports have high voltage and any attempt to connect a USB device in these ports will result in destruction of that device. There is also the possibility of damage to the computer system of the machine.



Downloading any program or changing any Rottler or Computer settings may cause the machine and/or software to become unstable. DO NOT install ANY screen saver, Anti-Virus, Spyware or any type of Security software on the computer. This could create a hazardous environment for the operator and personnel around the machine. Performing any of the above will also result in the machine warranty being NULL and VOID.



DO NOT connect any type of external hardware to the computer via USB or any other means. Do not install any type of Device Driver. This could create a hazardous environment for the operator and personnel around the machine. Performing any of the above will also result in the machine warranty being NULL and VOID.

## Electrical Safety Features Of Rottler DM Controlled Machines

All Rottler machines that use the DM operational control system are designed to comply with all applicable safety standards. This includes but is not limited to the following systems:

Thermal sensors in all motors and motor controls.

1. Current sensors in all motor control panels.
2. Electrical breakers to prevent voltage surges and spikes from reaching electrical system.
3. Electrical lockout on main electrical enclosure.
4. E-Stop that shuts down all operational systems in an event of an emergency.

All thermal and current limits for motors and motor controls are preset at the factory. In the event that any of those parameters are exceeded during operation of the machine, the machine control system will shut down the machine and a warning of the specific fault will appear on the control screen.

# CONTROL DEFINITIONS

## Contents

<b>Control Definitions .....</b>	<b>4-1</b>
<b>Computer and Controller System Safety for DM Controlled Machines .....</b>	<b>4-1</b>
Definitions Of Terminology Used In This Chapter .....	4-2
<b>Hand Controls .....</b>	<b>4-3</b>
E-STOP Switch .....	4-3
Handwheel .....	4-3
<b>Boot Up Screen .....</b>	<b>4-4</b>
Start Icon .....	4-4
<b>Set Up Screen .....</b>	<b>4-5</b>
Jog Button Panel .....	4-5
Program Select Section Buttons .....	4-6
Mode Select Sections Buttons and Menus. ....	4-6
Software Setup Menu .....	4-6
<b>Operation Screen .....</b>	<b>4-7</b>
Handwheel Buttons .....	4-7
<b>Operation Screen: Setup Tab .....</b>	<b>4-8</b>
Set Zeros Buttons .....	4-8
Z Stops .....	4-8
Cross Hatch Calculator .....	4-9
Stones Load Setup .....	4-9
Stroke Setup .....	4-9
<b>Operation Screen: Bore Locations Tab .....</b>	<b>4-9</b>
Move Buttons .....	4-10
Hone Buttons .....	4-10
Rotate Button .....	4-10
Left and Right Locations Tabs .....	4-10
<b>Operation Screen: Operation Tab .....</b>	<b>4-11</b>
Load Reading Button .....	4-11
Zero Stone Diameter Button .....	4-11

<b>Total Stock Removal Value Box .....</b>	<b>4-11</b>
<b>Operation Buttons .....</b>	<b>4-12</b>
<b>FEED STONES TO DIAMETER Button .....</b>	<b>4-12</b>
<b>Z CRASH DETECTION Button .....</b>	<b>4-12</b>
<b>CYCLE START Button .....</b>	<b>4-12</b>
<b>PLATEAU Button .....</b>	<b>4-13</b>
<b>HOLE TO HOLE Button.....</b>	<b>4-13</b>
<b>Pop Up Windows and Menus .....</b>	<b>4-13</b>
<b>Number Pad .....</b>	<b>4-13</b>
<b>Conformation Windows .....</b>	<b>4-14</b>
<b>Change and Choose Windows .....</b>	<b>4-14</b>
<b>Software Set Menus .....</b>	<b>4-15</b>
<b>On Screen Keyboard .....</b>	<b>4-16</b>
<b>STONE HOLDER SIZE CHART H70 SERIES .....</b>	<b>4-17</b>
<b>MEDIUM HONE HEAD .....</b>	<b>4-17</b>
<b>LARGE HONE HEAD .....</b>	<b>4-18</b>
<b>EXTRA LARGE HONE HEAD .....</b>	<b>4-20</b>



## Control Definitions

The purpose of this chapter is to define the function of the buttons throughout the various screens. Certain button functions may not make sense right away in this chapter. As the operator reads through the Operating Instructions chapter of this manual, the function of these buttons will become clear.

**NOTE:** Not all modes of operation will be discussed in this Chapter. The function of several buttons and actions are the same in many modes. The description of a function or button operation will not be repeated if it exists in another mode. All modes of operation will be discussed in the Operations Section of this manual.

## Computer and Controller System Safety for DM Controlled Machines

The computer and controller are located in the main rear electrical enclosure. This unit is a full computer, running Windows 7 64 Bit operating system. Contact the factory if more information on the computer system is required.

**IMPORTANT:** The computer in this machine has the ability to connect to the World Wide Web via Ethernet or Wireless using a USB wireless (Wi-Fi) adapter. Updating the Rottler software should **ONLY** be done when directed to do so by a Rottler service technician. Updating Rottler Software when not directed by Rottler personnel could result in a non-operational machine.

It is recommended that the machine be hooked up to the Internet anytime it is on. The software on the machine will automatically connect to our server to send back useful information on machine status. It will also record performance parameters that will be used to evaluate any occurrence of a malfunction.

The Auto Update for the Windows Firewall (Security) and Windows Defender (Anti-Virus) is turned on. The computer will automatically download the updates and then install them when the computer is shut down every Friday night.

Any "IT" personnel should **ALWAYS** get approval from Rottler before doing **ANYTHING** on the computer.

 **WARNING** Downloading ANY program from the Internet or by other means when not directed by Rottler is prohibited and will result in the machine warranty being NULL and VOID.

 **WARNING** Downloading any program or changing any Rottler or Computer settings may cause the machine and/or software to become unstable. **DO NOT** install ANY screen saver, Anti-Virus, Spyware or any type of Security software on the computer. This could create a hazardous environment for the operator and personnel around the machine. Performing any of the above will also result in the machine warranty being NULL and VOID.

## COMMON INTERFACE NOTICE

All Rottler machines using Direct Motion technology share a common control interface. This allows for a better environment for programming machine functions across a wide range of different machines. This also allows for easier deployment in shops already using Rottler Direct Motion machines.

Because of the common interface some machines may have buttons and menu tabs that may not be applicable to the machine that is being used. If the buttons or menu tabs are not mentioned in the control definitions section of the manual, they will not be used in machine operation.

### Definitions Of Terminology Used In This Chapter

**Screen:** This is what appears on the monitor. There are different screens for setting up the machine and to operate it.

**Icon:** A small graphic that is located on the screen. The Icon is used to activate various programs related to machine operation.

**Button:** A small graphic that is located on the screen as part of group of buttons that is used to set up or operate the machine. A button has two different possible functions. One is when it is used as switch. When it is used as switch the button will either be on or off after it has been pressed and must be pressed again to revert to start status. The second is as contact switch. This is also called a momentary contact button. This button is active only while it is being pressed by the operator.

**Click:** This is a method of activating an icon or button using a computer mouse. On a touch screen such as the one that this machine is equipped with you can use your finger tip or a stylus to activate the icon or button.

**Press or Touch:** Use your finger tip to activate a button on the screen.

**Activate:** A way of indicating that button, menu title, or tab has been clicked on or pressed.

**Tab:** A small box located near the top of the screen. A tab will be labeled with the function of a screen that will appear when the tab is clicked or touched.

**Value Box:** This is where values that are needed to run a program are entered. Touching a value box will cause a number pad to appear so that the desired value can be input.

**Menu Title:** A one or two word title that describes the contents of a menu. Clicking or touching an Option Title will cause a menu to appear below it.

**Menu:** A box that appears below an Option Title when it is activated. A menu will contain a number of functions that can be activated or deactivated by clicking or pressing the title. Or when activated another menu will open up with more functions that can be activated.

**Pop Up Window:** This is a box that will appear when certain buttons, menu titles, or value boxes are activated. These Pop Up Windows can be warnings, requests for input, or confirmation requests.



## Hand Controls

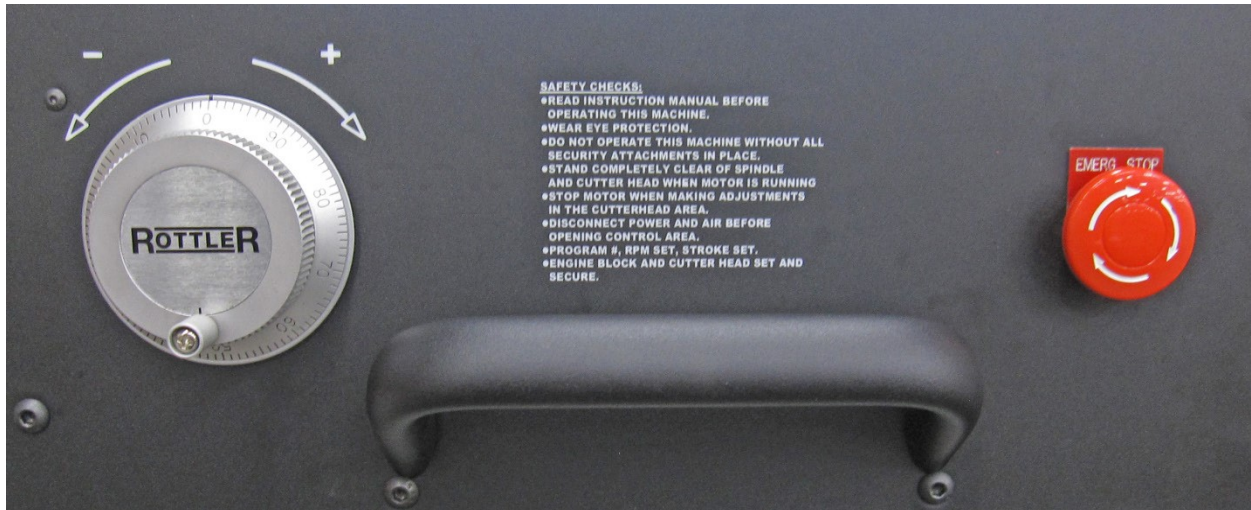

### E-STOP Switch

This switch is used in an emergency situation. Pushing the button in will disconnect the power to all the motors that run the machine except the coolant pump motor. The machine will stop dead in place when activated. To restore power to the machine turn the button clockwise until it pops out.

### Handwheel

The handwheel is used to manually move the machine in different directions according to which axis is activated. The handwheel is also used to manually feed the stones in or out.

### Boot Up Screen

This is the screen you will see when first turn on the power.



**Start Icon**

Double Click or double press to start the Rottler operating program

## Set Up Screen



## Jog Button Panel

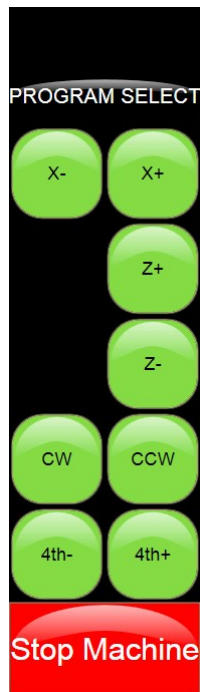

The jog buttons are momentary contact buttons. They activate rapid travel for the axis indicated on the button.

The X- button will move the carriage to the left.

The X+ button will move the carriage to the right.

The Z+ button will move the spindle up.

The Z- button will move the spindle down.

The CW button will rotate the spindle clockwise.

The CCW button will rotate the spindle counter clockwise.

The 4th- button will rotate the fixture cradle toward the back.

The 4th+ button will rotate the fixture cradle toward the front.

( The 4th axis buttons are only active when the optional auto rotate fixture is installed )

The Stop Machine button is used to stop the machine cycle before it has completed.

The machine will complete a hone stroke and raise out of the cylinder.



When this icon replaces the Stop Machine button it indicates that the E-STOP switch is engaged and all motions buttons on the screen are disabled. The E-STOP switch must be released before any of the motion buttons on the display screen will respond.

### Program Select Section Buttons



The Home button is used to index the home head when it is installed on the machine. FIXTURE SELECT, and TABLE OF TOOLS buttons are not used on the H75X.

The New and Options buttons are used for creating new engine block profiles that will be saved for later use. The Delete button is used for removing a block profile from the Program Select list.

### Mode Select Sections Buttons and Menus.

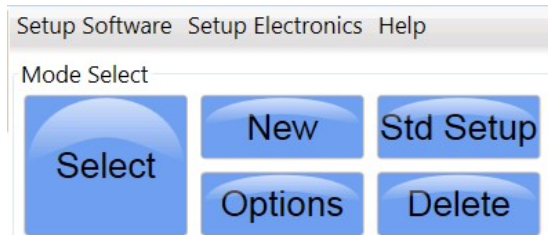

Setup Software and Setup Electronics menu titles will open new options menus. These are mostly used for machine setup at the factory or for service. There are 2 options that an operator can select if needed and will be explained further on.

The Help menu title will open the help and instruction files for the machine.

**New Button:** This button is used to bring up a pop up screen where a machining process will be chosen for use. The process will appear below the Mode Select buttons.

**Std Setup Button:** This button will insert all processes that are available for this machine in the area below the Mode Select buttons.

**Options Button:** This button will bring up a pop screen that will allow the operator to change the name of the process that was highlighted.

**Delete Button:** This button will delete any process that has been highlighted.

**Select Button:** This button will bring up the Operation Screen once a block program and a process have been highlighted.

### Software Setup Menu

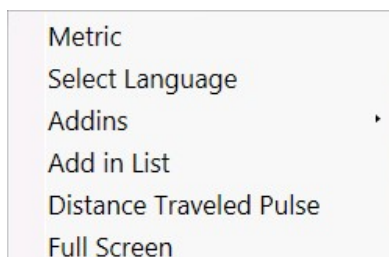

This is the menu that appears when the Setup Software title is touched. Here the operator can choose to change to metric display readings by checking the Metric title. Inch display readings can be restored by unchecking the Metric title box.

A different language can be used by touching the Select Language title and choosing for the languages that appear.

## Operation Screen

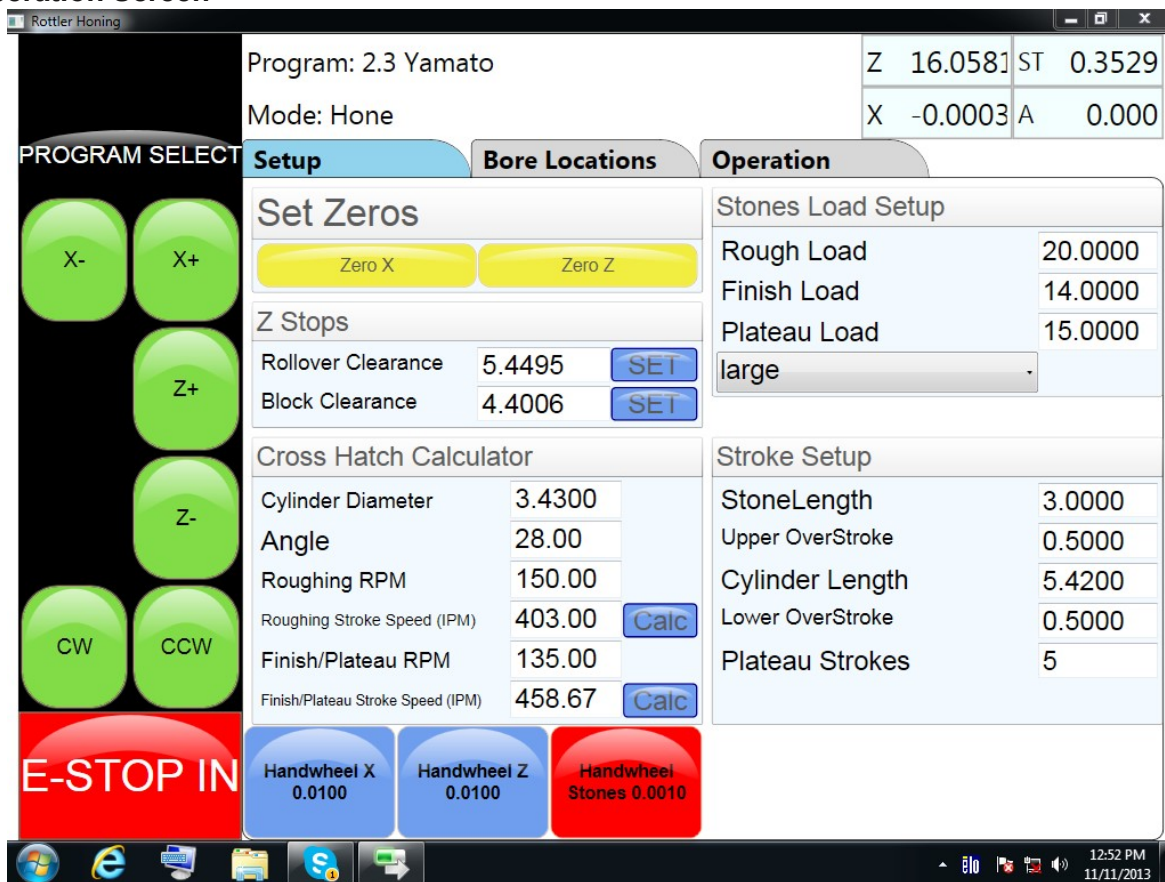

At the top of the screen you will see the block and process that was selected. In the upper right section there is a readout of current location of the different axis's. **All readings are plus or minus from the zero set points.** ( The A axis readout in this case is the 4th axis and will only show a reading if the optional auto rotate fixture is installed )

**Screen Tabs:** When the Setup, Bore Locations, or Operation tab is touched the corresponding screen for that tab will appear. These different screens are used for programing and operation of the machine.

### Handwheel Buttons

At the bottom of the screen are 4 buttons. When a button is touched and activated the operator will be able to control the axis indicated on the button by using the handwheel. The active button will turn red after it is touched.

**Handwheel X Button:** When this button is activated the operator will be able to move the carriage to the right or left using the handwheel. Each notch or click of the handwheel will move the carriage 0.010 of an inch. Turning the handwheel clockwise or to the plus side will cause the carriage to move to the right. Turning the handwheel counter clockwise or to the minus side will cause the carriage to move to the left.

**Handwheel Z Button:** When this button is activated the operator will be able to move the spindle up or down using the handwheel. Each notch or click of the handwheel will move the spindle 0.010 of an inch. Turning the handwheel clockwise or to the plus side will cause the spindle to move up. Turning the handwheel counter clockwise or to the minus side will cause the spindle to move down.

**Handwheel Stones Button:** When this button is activated the operator will be able to feed the stones in or out using the handwheel. Each notch or click will increase or decrease the diameter of the stones by 0.001 of an inch. Turning the handwheel clockwise or to the plus side will cause the stones in increase in diameter. Turning the handwheel counter clockwise or to the minus side will cause the stones to decrease in size.

**Handwheel Forth Button:** When this button is activated the operator will be able to rotate the fixture cradle forward or backward. Each notch or click of the handwheel will rotate the cradle 0.050 of a degree. Turning the handwheel clockwise or to the plus side will rotate the cradle towards the front of the tank. Turning the handwheel counter clockwise or to the minus side will rotate the cradle towards the back of the tank. ( This button is only active if the optional auto rotate fixture has been installed )

**Operation Screen: Setup Tab**

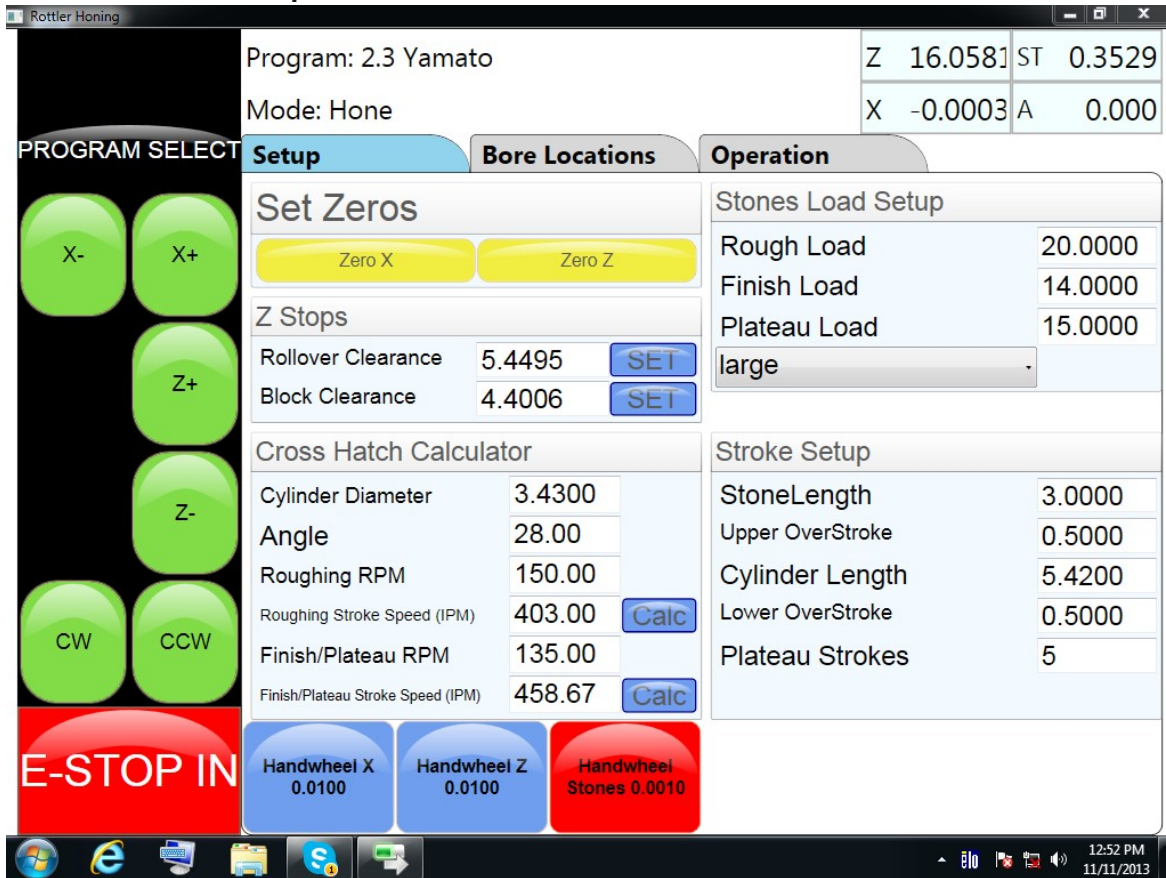

**Set Zeros Buttons**

These button will set the zero point for each axis that is indicated on the button. When touched a conformation pop up screen will appear to confirm that the operator wants to set the zero point.

**Z Stops**

This section is where the clearance height for the hone head is set. A value can be entered by touching the value box and keying in the value on the pop up number pad. Or the hone head can be moved to the

desired location using the Z Axis jog button or handwheel. When the hone head is in the desired position the operator can touch the set button to enter the value that is in the value box.

**Cross Hatch Calculator**

This section is where the operator will enter values into the appropriate boxes to set up the auto cross hatch function. After the values have been entered the operator will press the Calc button to determine the proper RPM to achieve the desired cross hatch angle.

**Stones Load Setup**

This is the section where the operator will enter the desired running loads for different processes. Values are entered by touching the proper value box and entering the desired value on the number pad that appears. The operator will also indicate which hone head will be used for the job.

**Stroke Setup**

This is the section where the operator will enter information to determine how far the spindle will travel while it is stroking up and down. The bottom value box is where the number of strokes to be used in the plateau mode is entered.

**Operation Screen: Bore Locations Tab**

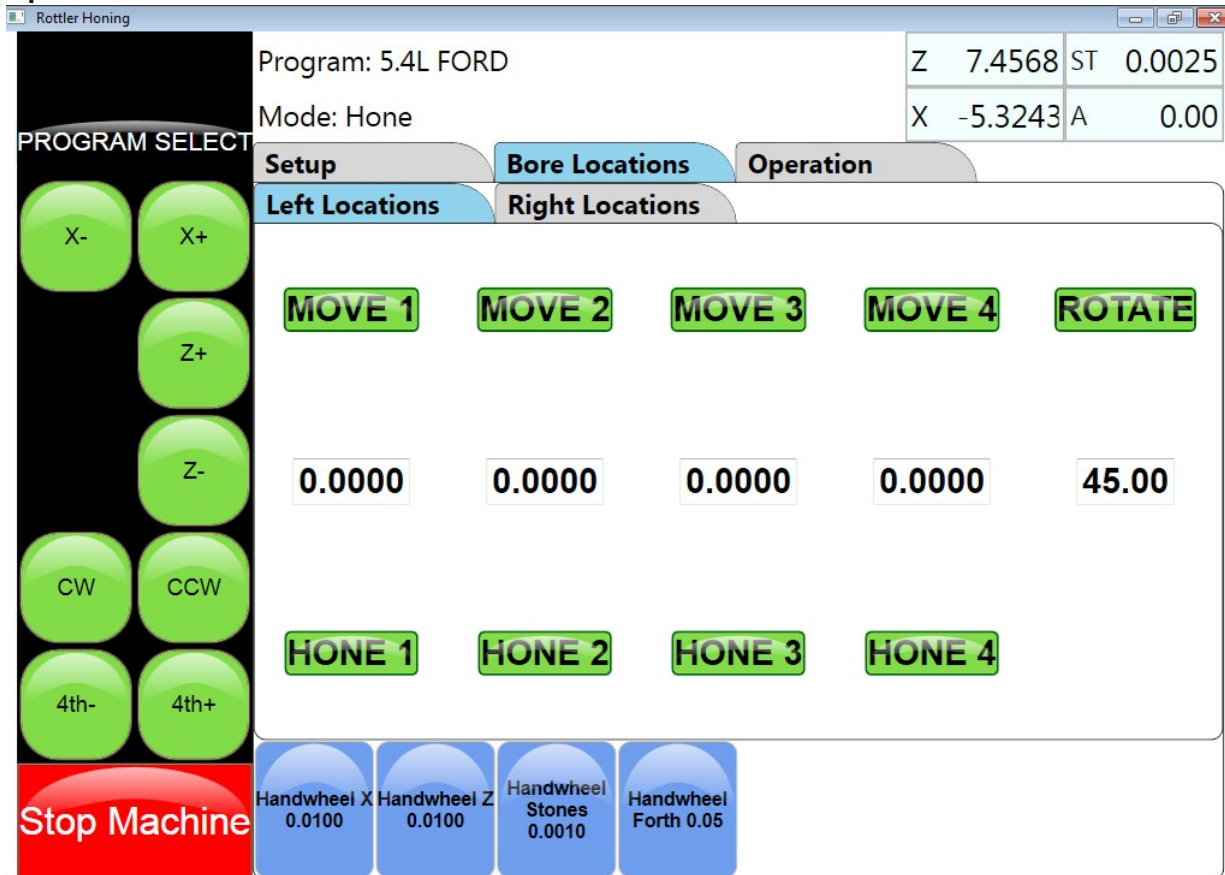

This is the screen where the operator will enter the values for center to center bore dimensions. This will enable the machine to move automatically from bore to bore. Move 1 value will be 0.000 since this

is the start point for the honing process. Each succeeding value box will add the center to center bore dimension to the previous value.

**Move Buttons**

If the operator touches one of the Move buttons the carriage will move to the position that is entered in the value box below the button.

**Hone Buttons**

These buttons are used to determine if that cylinder will be honed during the auto honing process. When touched the button will turn yellow and indicated that the cylinder will not be honed during the auto honing process. Individual buttons can be deactivated if the operator wants to bypass honing a specific cylinder during the auto honing process.

**Rotate Button**

This button when touched will rotate the fixture cradle to the point that is entered in the value box. This will be the start point for honing the cylinders on location screen. ( This button is active only if the optional auto rotate fixture is installed )

**Left and Right Locations Tabs**

If a V Block is to be honed then it will be necessary to enter values for the right side bank after touching the Right Locations tab to bring up the screen. The values will be different than for the left side since there will be a need to account for the cylinder offset from bank to bank. This will be covered fully in the Operations Chapter.



## Operation Screen: Operation Tab

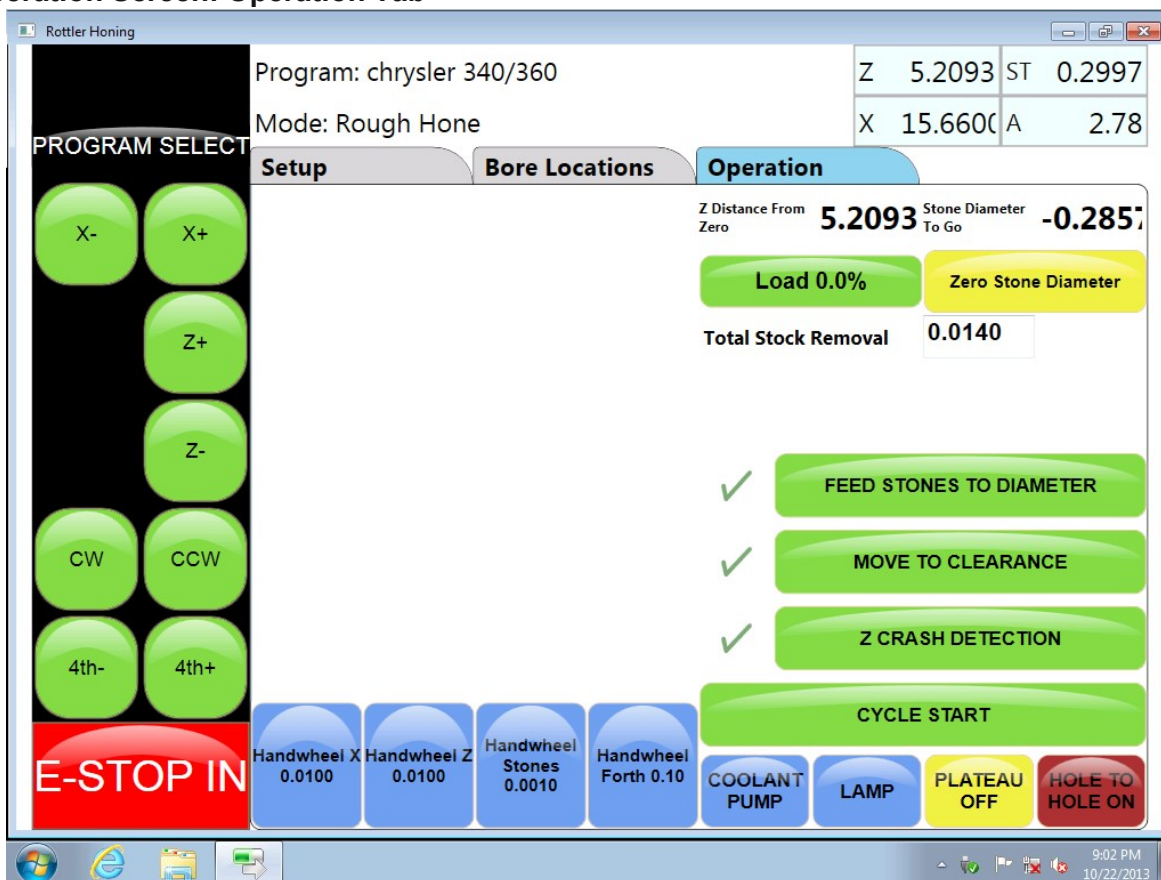

This is the screen where the honing operation will be run from. At the top under the Operation Tab are 2 readouts. The first is Z Distance From Zero. This reading shows the location of the spindle from the zero point. The second is Stone Diameter To Go. This readout shows how much the stones must still feed out to reach the Total Stock Removal setting.

### Load Reading Button

This is a non-functional button. This is where the spindle motor load reading is displayed. The button color will change as load increases. Green indicates that the motor load is in its optimal area. Yellow indicates that the motor load is slightly high. Red indicates that the motor load is excessive.

### Zero Stone Diameter Button

This button is used to set the zero setting for the stone diameter.

### Total Stock Removal Value Box

This is where the operator will enter a value for the amount of stock to be removed from a cylinder.

## Operation Buttons



### FEED STONES TO DIAMETER Button

When this button is active touching it will cause the spindle motor to start and the stones to feed out until the finish load setting is reached. When that occurs the spindle motor will shut off. This is the zero point for the stone diameter. The operator will touch the Zero Stone Diameter button to set the zero point for the stones. This button is active only if the check mark is visible next to the button. The check can be turned on or off by touching the check mark box.

### Z CRASH DETECTION Button

When this button is active the machine will automatically detect and interference points that will come in contact with the bottom of the stones. When auto cycle is started the machine will run a test to determine if there is any interference points on each cylinder before honing begins. If an interference point is detected the machine will stop. When the machine is moving from cylinder to cylinder the machine will detect if the stones are not properly entering the bore and stop before damage can occur.

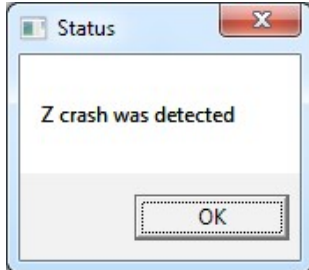

If there is an occurrence of an interference point being detected the machine will stop and a pop up screen will appear on the screen.

### CYCLE START Button

This is the button that is touched to begin the auto honing cycle process. The machine will complete the entire process of honing all the cylinders that have been tagged to hone. The machine can be stopped mid cycle by touching the Stop Machine button. If an emergency arises or if the screen does not respond to touch commands the E-STOP can be used to stop the machine.

### COOLANT PUMP and LAMP BUTTONS



These buttons turn the coolant pump and lamps on or off. When they are on they will be red in color. The coolant pump and lamps have an independent power supply and will work even if the E-STOP is engaged.

### PLATEAU Button



This button will turn the Plateau mode on or off. When it is on the button will turn red and the numbers of strokes to be used for the process is displayed on the button.

### HOLE TO HOLE Button



This button will turn on the automatic hole to hole honing process. When the button is red and ON is displayed the machine will automatically move to each hole in the programmed process that is engaged by touching the CYCLE START button. When button is yellow and OFF is displayed on the button only the cylinder that is aligned with the stones will be honed.

## Pop Up Windows and Menus

### Number Pad

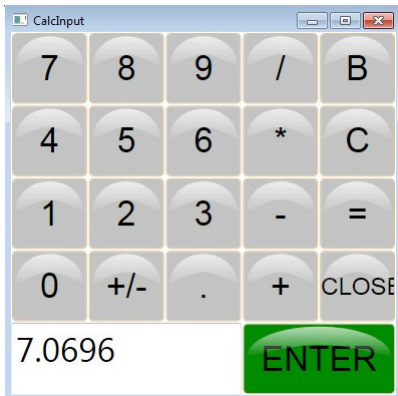

This window will pop up when the operator touches a value box. The operator will input the value desired and then touch ENTER to place the value in the value box.

### Conformation Windows

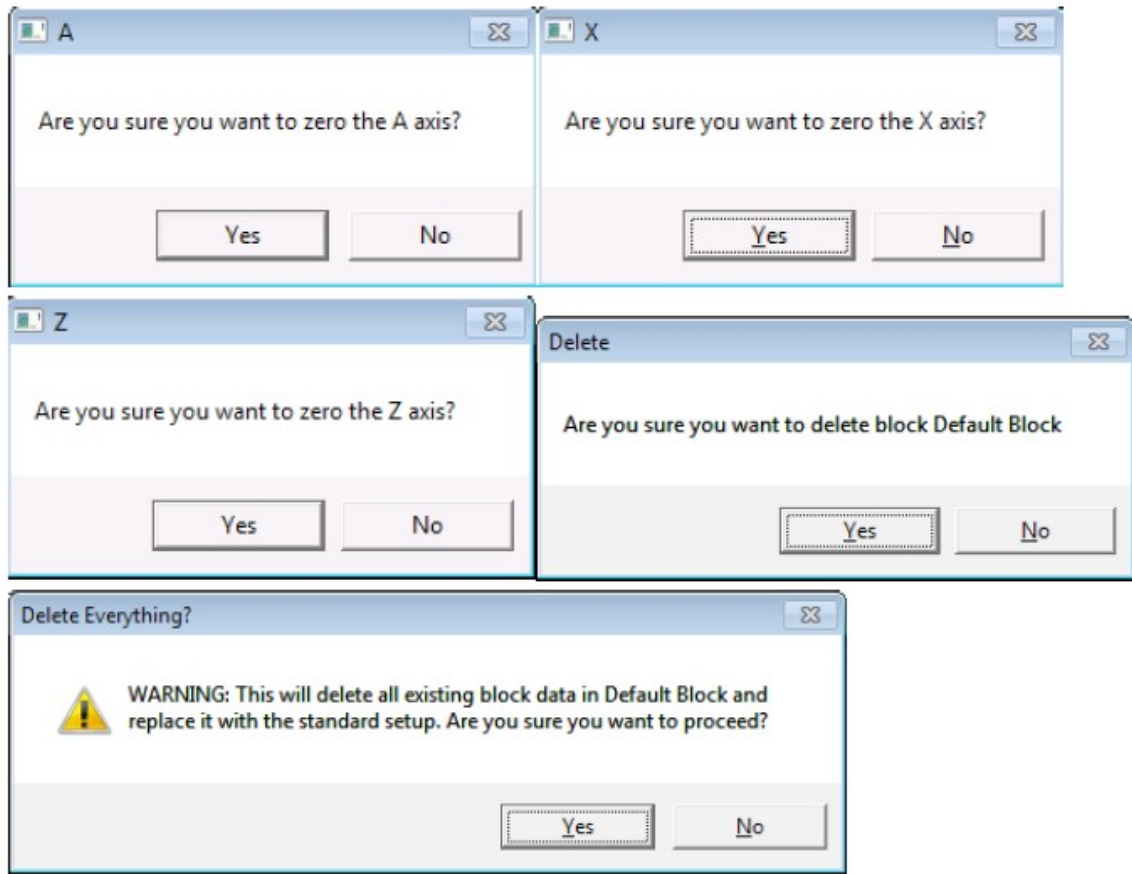

These windows will pop up to confirm that the operator wants complete an action.

### Change and Choose Windows

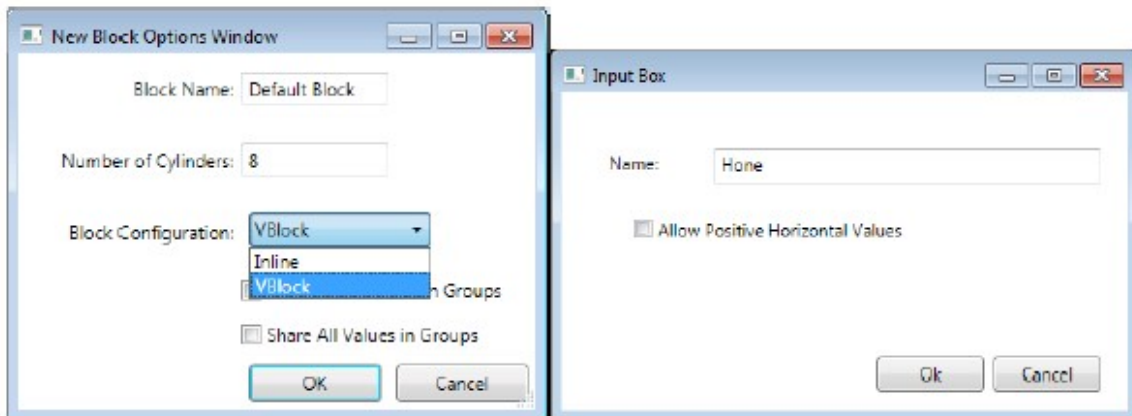

These windows will pop up when the operator wants to enter or change information.

**Software Set Menus**

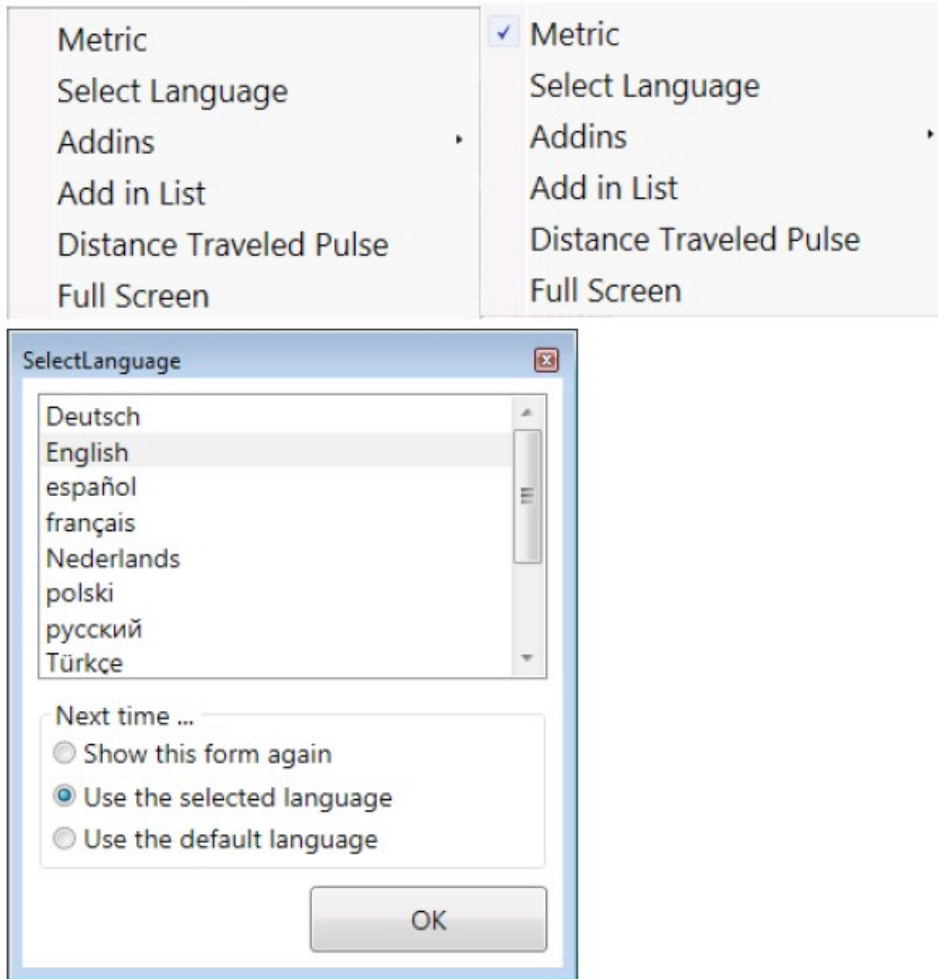

These menus are for selecting the metric screen readouts and language.

## On Screen Keyboard

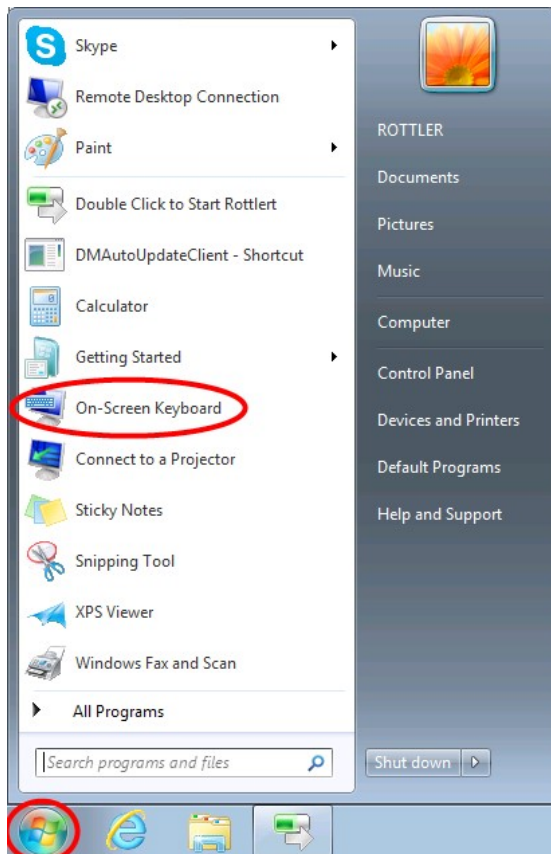

If a keyboard is not attached the machine an on screen keyboard can be used.

To access the on screen keyboard touch the Start button and then touch the On-Screen Keyboard Icon.

## STONE HOLDER SIZE CHART H70 SERIES MEDIUM HONE HEAD

Diameter (New Stones) Inches				
	0.312	Stones	0.2	Stones
	Min	Max	Min	Max
514-13-13A	2.34	2.45	2.12	2.23
514-10-13B	2.54	2.65	2.32	2.43
514-10-13C	2.74	2.85	2.52	2.63
514-10-13D	2.94	3.05	2.72	2.83
Diameter (New Stones) (Metric)				
	7.9248	Stones	5.08	Stones
	Min	Max	Min	Max
514-13-13A	59.44	62.23	53.75	56.54
514-10-13B	64.52	67.31	58.83	61.62
514-10-13C	69.60	72.39	63.91	66.70
514-10-13D	74.68	77.47	68.99	71.78
Diameter (New Brushes ) Inches				
	0.55	Stones	0.395	Stones
	Min	Max	Min	Max
514-13-13A	2.82	2.93	2.51	2.62
514-10-13B	3.02	3.13	2.71	2.82
514-10-13C	3.22	3.33	2.91	3.02
514-10-13D	3.42	3.53	3.11	3.22
Diameter (New Brushes) (Metric)				
	13.97	Stones	10.033	Stones
	Min	Max	Min	Max
514-13-13A	71.53	74.32	63.65	66.45
514-10-13B	76.61	79.40	68.73	71.53
514-10-13C	81.69	84.48	73.81	76.61
514-10-13D	86.77	89.56	78.89	81.69

**LARGE HONE HEAD**

Diameter (New Stones) Inches				
	0.312	Stones	0.2	Stones
	Min	Max	Min	Max
514-9-6J	2.99	3.45	2.77	3.23
514-9-6A	3.17	3.63	2.94	3.41
514-9-6B	3.42	3.88	3.19	3.66
514-9-6C	3.67	4.13	3.44	3.91
514-9-6D	3.92	4.38	3.69	4.16
514-9-6E	4.17	4.63	3.94	4.41
514-9-6F	4.42	4.88	4.19	4.66
514-9-6G	4.67	5.13	4.44	4.91
514-9-6H	4.92	5.38	4.69	5.16
514-9-6K	5.17	5.63	4.94	5.41
514-9-6L	5.42	5.88	5.19	5.66
514-9-6M	5.67	6.13	5.44	5.91
514-9-6N	5.92	6.38	5.69	6.16
514-9-6P	6.17	6.63	5.94	6.41
514-9-6Q	6.42	6.88	6.19	6.66
514-9-6R	6.67	7.13	6.44	6.91
514-9-6S	6.92	7.38	6.69	7.16
Diameter (New Stones) (Metric)				
	7.9248	Stones	5.08	Stones
	Min	Max	Min	Max
514-9-6J	75.92	87.73	70.23	82.04



514-9-6A	80.39	92.20	74.70	86.51
514-9-6B	86.74	98.55	81.05	92.86
514-9-6C	93.09	104.90	87.40	99.21
514-9-6D	99.44	111.25	93.75	105.56
514-9-6E	105.79	117.60	100.10	111.91
514-9-6F	112.14	123.95	106.45	118.26
514-9-6G	118.49	130.30	112.80	124.61
514-9-6H	124.84	136.65	119.15	130.96
514-9-6K	131.19	143.00	125.50	137.31
514-9-6L	137.54	149.35	131.85	143.66
514-9-6M	143.89	155.70	138.20	150.01
514-9-6N	150.24	162.05	144.55	156.36
514-9-6P	156.59	168.40	150.90	162.71
514-9-6Q	162.94	174.75	157.25	169.06
514-9-6R	169.29	181.10	163.60	175.41
514-9-6S	175.64	187.45	169.95	181.76

Diameter (New Brushes ) Inches				
	0.55	Stones	0.395	Stones
	Min	Max	Min	Max
514-9-6J	3.47	3.93	3.16	3.62
514-9-6A	3.64	4.11	3.33	3.80
514-9-6B	3.89	4.36	3.58	4.05
514-9-6C	4.14	4.61	3.83	4.30
514-9-6D	4.39	4.86	4.08	4.55

514-9-6E	4.64	5.11	4.33	4.80
514-9-6F	4.89	5.36	4.58	5.05
514-9-6G	5.14	5.61	4.83	5.30
514-9-6H	5.39	5.86	5.08	5.55
514-9-6K	5.64	6.11	5.33	5.80
514-9-6L	5.89	6.36	5.58	6.05
514-9-6M	6.14	6.61	5.83	6.30
514-9-6N	6.39	6.86	6.08	6.55
514-9-6P	6.64	7.11	6.33	6.80
514-9-6Q	6.89	7.36	6.58	7.05
514-9-6R	7.14	7.61	6.83	7.30
514-9-6S	7.39	7.86	7.08	7.55
Diameter (New Brushes) (Metric)				
	13.97	Stones	10.033	Stones
	Min	Max	Min	Max
514-9-6J	88.01	99.82	80.14	91.95
514-9-6A	92.48	104.29	84.61	96.42
514-9-6B	98.83	110.64	90.96	102.77
514-9-6C	105.18	116.99	97.31	109.12
514-9-6D	111.53	123.34	103.66	115.47
514-9-6E	117.88	129.69	110.01	121.82
514-9-6F	124.23	136.04	116.36	128.17
514-9-6G	130.58	142.39	122.71	134.52
514-9-6H	136.93	148.74	129.06	140.87
514-9-6K	143.28	155.09	135.41	147.22

514-9-6L	149.63	161.44	141.76	153.57
514-9-6M	155.98	167.79	148.11	159.92
514-9-6N	162.33	174.14	154.46	166.27
514-9-6P	168.68	180.49	160.81	172.62
514-9-6Q	175.03	186.84	167.16	178.97
514-9-6R	181.38	193.19	173.51	185.32
514-9-6S	187.73	199.54	179.86	191.67

**EXTRA LARGE HONE HEAD**

Diameter (New Stones) Inches				
	0.312	Stones	0.2	Stones
	Min	Max	Min	Max
514-9-24A	6.24	6.43	6.02	6.21
514-9-24B	6.44	6.63	6.22	6.41
514-9-24C	6.74	6.93	6.52	6.71
514-9-24D	7.04	7.23	6.82	7.01
514-9-24E	7.34	7.53	7.12	7.31
514-9-24F	7.64	7.83	7.42	7.61
514-9-24G	7.94	8.13	7.72	7.91
514-9-24H	8.24	8.43	8.02	8.21
514-9-24J	8.54	8.73	8.32	8.51
514-9-24K	8.84	9.03	8.62	8.81
514-9-24L	9.14	9.33	8.92	9.11
514-9-24M	9.44	9.63	9.22	9.41
514-9-24N	11.02	11.21	10.80	10.99

514-9-24P	11.79	11.98	11.57	11.76
Diameter (New Stones) (Metric)				
	7.9248	Stones	5.08	Stones
	Min	Max	Min	Max
514-9-24A	158.50	163.32	152.81	157.63
514-9-24B	163.58	168.40	157.89	162.71
514-9-24C	171.20	176.02	165.51	170.33
514-9-24D	178.82	183.64	173.13	177.95
514-9-24E	186.44	191.26	180.75	185.57
514-9-24F	194.06	198.88	188.37	193.19
514-9-24G	201.68	206.50	195.99	200.81
514-9-24H	209.30	214.12	203.61	208.43
514-9-24J	216.92	221.74	211.23	216.05
514-9-24K	224.54	229.36	218.85	223.67
514-9-24L	232.16	236.98	226.47	231.29
514-9-24M	239.78	244.60	234.09	238.91
514-9-24N	279.91	284.73	274.22	279.04
514-9-24P	299.47	304.29	293.78	298.60

Diameter (New Brushes ) Inches				
	0.55	Stones	0.395	Stones
	Min	Max	Min	Max
514-9-24A	6.72	6.91	6.41	6.60
514-9-24B	6.92	7.11	6.61	6.80
514-9-24C	7.22	7.41	6.91	7.10
514-9-24D	7.52	7.71	7.21	7.40
514-9-24E	7.82	8.01	7.51	7.70

514-9-24F	8.12	8.31	7.81	8.00
514-9-24G	8.42	8.61	8.11	8.30
514-9-24H	8.72	8.91	8.41	8.60
514-9-24J	9.02	9.21	8.71	8.90
514-9-24K	9.32	9.51	9.01	9.20
514-9-24L	9.62	9.81	9.31	9.50
514-9-24M	9.92	10.11	9.61	9.80
514-9-24N	11.50	11.69	11.19	11.38
514-9-24P	12.27	12.46	11.96	12.15
Diameter (New Brushes) (Metric)				
	13.97	Stones	10.033	Stones
	Min	Max	Min	Max
514-9-24A	170.59	175.41	162.71	167.54
514-9-24B	175.67	180.49	167.79	172.62
514-9-24C	183.29	188.11	175.41	180.24
514-9-24D	190.91	195.73	183.03	187.86
514-9-24E	198.53	203.35	190.65	195.48
514-9-24F	206.15	210.97	198.27	203.10
514-9-24G	213.77	218.59	205.89	210.72
514-9-24H	221.39	226.21	213.51	218.34
514-9-24J	229.01	233.83	221.13	225.96
514-9-24K	236.63	241.45	228.75	233.58
514-9-24L	244.25	249.07	236.37	241.20
514-9-24M	251.87	256.69	243.99	248.82
514-9-24N	292.00	296.82	284.12	288.95
514-9-24P	311.56	316.38	303.68	308.51

# OPERATING INSTRUCTIONS

## Contents

<b>Honing In General .....</b>	<b>5-1</b>
<b>Large Amount of Material Removal .....</b>	<b>5-1</b>
<b>Common Surface Finishes .....</b>	<b>5-1</b>
Non-Plateau .....	5-1
Plateau .....	5-2
Plateau Caution .....	5-2
Method 1 .....	5-2
Step One .....	5-2
Step Two .....	5-2
Step Three .....	5-2
Method 2 .....	5-3
Moly Rings or Shorter Duty Cycle Engine Applications .....	5-3
<b>Productivity: .....</b>	<b>5-3</b>
Single Step Honing .....	5-3
<b>Two Step honing .....</b>	<b>5-4</b>
Step One .....	5-4
Step Two .....	5-4
<b>Using Vitrified Abrasives .....</b>	<b>5-5</b>
<b>Using Diamond Abrasives .....</b>	<b>5-5</b>
General .....	5-5
Scratching .....	5-6
Breaking In A New Set of Diamond Abrasives .....	5-6
Dressing Diamond Abrasives .....	5-6
Torn Metal .....	5-6
Stock Removal Rate .....	5-6
Diameter Range .....	5-7
<b>Cross Hatch Angle and Washout .....</b>	<b>5-7</b>
<b>Coolant .....</b>	<b>5-7</b>
Coolant types and Selection .....	5-7

<b>Refractometer</b> .....	<b>5-7</b>
<b>Coolant Pump System</b> .....	<b>5-7</b>
<b>Honing of Alusil, Silitec, and Lokasil Materials</b> .....	<b>5-7</b>
<b>Instructions for Honing Alusil and Lokasil Cylinders</b> .....	<b>5-8</b>
<b>When Honing Silitec Cylinders</b> .....	<b>5-8</b>
<b>Honing a Cylinder Block</b> .....	<b>5-9</b>
<b>Introduction</b> .....	<b>5-9</b>
<b>Getting Started</b> .....	<b>5-10</b>
<b>Planning the Job</b> .....	<b>5-11</b>
<b>Block Specifications</b> .....	<b>5-11</b>
<b>Riser Block Selection</b> .....	<b>5-12</b>
<b>Tooling Selection</b> .....	<b>5-13</b>
<b>STONE HOLDER SIZE CHART H70 SERIES</b> .....	<b>5-14</b>
<b>MEDIUM HONE HEAD 514-10-20</b> .....	<b>5-14</b>
<b>LARGE HONE HEAD 514-9G</b> .....	<b>5-15</b>
<b>EXTRA LARGE HONE HEAD 514-9D</b> .....	<b>5-17</b>
<b>Stone and Brush Selection</b> .....	<b>5-19</b>
<b>Loading the Block</b> .....	<b>5-20</b>
<b>Programing Set Up</b> .....	<b>5-21</b>
<b>Creating a Program</b> .....	<b>5-24</b>
<b>Mode Select Section of Home Screen</b> .....	<b>5-26</b>
<b>Operations Setup Screen</b> .....	<b>5-29</b>
<b>Setup Tab</b> .....	<b>5-29</b>
<b>Bore Locations Tab</b> .....	<b>5-31</b>
<b>Setting Zeros</b> .....	<b>5-32</b>
<b>Setting Bore Locations</b> .....	<b>5-33</b>
<b>Operation Tab Settings</b> .....	<b>5-36</b>
<b>Setting Final Bore Size</b> .....	<b>5-36</b>
<b>Plateau Honing</b> .....	<b>5-38</b>
<b>Saving block program</b> .....	<b>5-38</b>





## Honing In General

The H75X is capable of honing a cylinder very accurately with very little or no work from the operator. The goal of the operator should be to create or choose a block program for the engine being honed. And select the proper hone head, stone holders, and stone set that will allow the machine to hone the cylinder to size with the correct finish.

While the H75X is running, the screen will show a representation of the hone head traveling up and down in the cylinder. Along the sides will be a line that represents the cylinder wall. While the machine is honing those lines will approximate the shape of the cylinder. If a section of the cylinder is tight then the lines will move toward the hone head. When the tight area exceeds a predetermined amount a red mark will appear in the area and the machine will dwell or short stroke in that area to remove the tight spot.

The H75X uses a two-step process when a cylinder is honed. When the cycle is started the machine will run a high pressure roughing load that will allow for quick stock removal. When the cylinder is near finish size the machine will automatically switch to a finish mode that lowers the pressure to allow for truing of bore geometry and final sizing.

## Large Amount of Material Removal

When you have large amounts of material to remove from a cylinder (.005 and up) the following steps should be used to maintain size control.

For stock removal of .010 or more it is best to use a two step process. Start with 80 grit stones, (.004" removal per minute) use the Rough Hone process and bring all cylinders to within .005" of the final size. Switch to stones that will leave you the desired RA value and remove the final amount of material using the Finish Hone process.

When there is less than .010" to remove start with 270 grit stones and bring cylinders to within .002" of final size using the Rough Hone process. Switch to stones that will leave you the desired RA value and remove the final amount of material using the Finish Hone process. You can also use the 270 grit stones and bring the cylinder to final size. Then install finishing stones and activate the PLATEAU operation to bring the cylinder to your desired RA value.

## Common Surface Finishes

Today's modern engines are demanding smoother and more precise surface finishes. There are two commonly used plateau surface finishes in automotive engine cylinder bore finishing today. They are both described below. The single step, non-plateau finish is no longer recommended for engine cylinder bores. The processes described below are commonly used in the engine building industry. If the engine or ring manufacturer recommends a particular finish the engine manufacturers specifications or ring manufactures recommendation should be followed.

### Non-Plateau

The typical Ra finishes used for a Non-Plateau finish should be in the 16-24 range. A 16-24 Ra finish leaves adequate peaks to be knocked off during the engine break in period yet is not so rough as to cause oil burning problems before the cylinder walls have been plateaued by the rings. During initial start

up of the engine the rings will create the plateau by knocking off the peaks of a non-plateau finish. Most modern ring manufacturers do not recommend using this type of finish.

### **Plateau**

Plateau surface finishes are required to meet the demands of the modern engine designs whether the engine is a standard automotive engine or a performance engine. There are sophisticated measuring devices able to measure the details of a plateau finish. Although the cost of these devices have lowered significantly in the last few years, they are still cost prohibitive to the average shop. Rottler has established honing procedures, if closely followed, will produce a finish meeting the specifications of the engine or ring manufacturers.

Below are the current finish recommendations for most automotive engines.

Ra	10 to 20
Rpk	10 to 20
Rvk	30 to 60
Rk	25 to 50

The Plateau finish has become very popular. One of its purposes is to minimize the break-in or ring seating period. A plateau finish involves the use of a roughing stone followed by a finer grit finishing stone. When the finishing stone is used, only a few strokes are required to create the plateau. If you were to continue honing with the finer grit stone you would eventually eliminate the plateau effect and create a simple non-plateau finish equal in roughness to the finish stone.

### **Plateau Caution**

When using plateau brushes do not exceed 7 strokes. Doing so may cause burnishing of the bore surface, which lead to improper ring seating and excess oil consumption.

Following are two slightly different methods for achieving the above finish. They differ slightly depending on the end use of the engine.

### **Method 1**

#### **Cast Iron Rings or Tougher Duty Cycle Applications**

This finish is used for cast iron rings or with moly rings where the end use of the engine is for tough or long duty cycle application – dirt track racing or standard automotive use.

### **Step One**

Use part number 514-9-14K (170/200grit) diamond stones. Use the Rough Hone process with a roughing load of 50% and a finishing load of 20%. Hone the cylinder to size.

### **Step Two**

Use part number 514-9-14L for 5 strokes in each cylinder. You can use the PLATEAU process with a 20% load setting. Caution do not hone longer than 5 strokes or shorter than 5 strokes. This will affect your overall finish.

**Step Three**

After using the 514-9-14L stones install the 514-9-14H brushes for plateau finishing. Use the PALTEAU process and brush each cylinder 3 strokes.

**Method 2****Moly Rings or Shorter Duty Cycle Engine Applications**

This finish is used with moly rings where the end use of the engine is for short duty cycles such as drag racing.

**Step One:**

Use part number 514-9-14J (270/325grit) diamond stones. Use the Rough Hone process with a roughing load of 50% and a finishing load of 20%. Hone the cylinder to size.

**Step Two:**

Use part number 514-9-14L for 5 strokes in each cylinder. You can use the PLATEAU MODE 1 with a 20% load setting. Caution do not hone longer than 5 strokes or shorter than 5 strokes. This will affect your overall finish.

**Step Three:**

After using the 514-9-14L stones install the 514-9-14H brushes for plateau finishing. Use the PALTEAU process and brush each cylinder 3 strokes.

**Productivity:**

The honing process should be studied to maximize the productivity of the work center while providing the desired end result. Following is an example of two different ways to accomplish the same end result of an 18-22 Ra non-plateau finish. The customer requires .003 in./0.07mm stock removal for honing after boring.

**Single Step Honing**

Process: Rough Hone

Abrasive: Diamond 500 Grit.

Set machine stop to hone to size. 60 strokes per minute. Set the roughing load at 85%. Set the finishing load between 25 and 35%. At .0003 in./0.007mm per feed out a stock removal rate of .0015 in./0.038mm per minute is achieved. The result is 2 minutes of honing time per cylinder.

During this time the machine is running unattended allowing the operator to accomplish other tasks. Rottler no longer recommends a single step honing process to finish engine cylinder bores.

Total honing time for a V8 block = 16 minutes.

## Two Step honing

### Step One

Process: Rough Hone

Abrasive: Diamond 270 Grit

Set Feed Ring to leave .0005" / .01mm maximum for second honing process. 60 Strokes per Minute. 70% Roughing Load and 30% Finish Load. When using the precision hone head you will achieve .003" / .076mm per minute stock removal. The result is 55 seconds of honing time per cylinder. During this time the H75X is running unattended allowing the operator to accomplish other tasks.

Honing time for a V8 block = 7.3 minutes

### Step Two

Process: Finish Hone

Abrasive: Diamond 500 Grit

Set Feed Ring to hone to size. 60 Strokes per Minute. 70% Roughing Load and 30% Finish Load. . When using the precision hone head you will achieve .0015" / .038mm per minute stock removal. The result is 24 seconds of honing time per cylinder.

Honing time for a V8 block = 3.2 minutes

Total honing time for a V8 Block with a Two Step Process = 10.5 minutes

#### **Note:**

When looking at actual honing time only, the two step process is 5.5 minutes faster than the single step process. Because the operator must change abrasives in the two-step process 1-2 minutes should be added for two abrasive changes.

The single step process would allow the operator to easily run two machines at one time or perform work other than honing.

The two step process becomes more effective as the ending surface finish requirement becomes smoother. If a 12 - 16 Ra finish was required, the honing time for a single step process would become approximately 24 minutes and the honing time for the two-step process would remain near 10.5 minutes. The two step process becomes more productive when more than .003 of material must be removed.

The above calculations should be made to determine the best method for the customer's particular requirements. Actual times will vary depending on the engine block material, stock removal required, and the desired accuracy. The purpose of the above comparison help the user understand different methods may be used to obtain the same result and that there is a significant difference in potential productivity when comparing the different methods.

## Using Vitrified Abrasives

Abrasive grades are available for most any finish you want to achieve. Two or three bond hardnesses are available with most grits. The right bond hardness will break down gradually depending on the grit used. Too soft a bond will lose abrasive excessively. Too hard a bond will chatter and start glazing the bore, with rapid heating and poor stock removal.

Finer grit stones generally break down much faster than coarse grit does. They must break down quickly to prevent the stone from loading or glazing.

Bond hardness will act differently with different cutting oils. Rottler abrasives were designed to be used with Rottler honing oils or equivalent. In general, Rottler honing oil is of low Sulfur content. Using other honing oils may have an adverse effect on the abrasive performance. Faster spindle rotation and light pressures will make abrasive act harder. Faster stroke speed and heavy pressures will make abrasive act softer.

Abrasive should wear relatively evenly and parallel to the shim support. If you encounter uneven abrasive wear, the cause may be damaged universal drive joint, unmatched stones, or misalignment of hone drive with cylinder bore.

Standard Vitrified abrasives can not be used in synthetic or water base coolants.

Generally, lighter honing pressures are required when using vitrified stones compared with diamond stones. The finer the grit the lighter the load should be as follows.

80 Grit	40 – 60%
180 Grit	40 – 60%
220 Grit	30 – 50%
320 Grit	20 – 40%
400 Grit	10 – 30%
600 Grit	05 – 25%

See Options chapter in the manual for list of available abrasives.

## Using Diamond Abrasives

### General

In the proper application, diamond abrasives are very effective for cylinder honing. The Rottler Precision Hone Head brings the cost of diamond honing down to a range that is much more affordable. Competitive hone heads require the purchase of multiple hone heads to cover the same size range as the Precision Head. The Rottler system is approximately 1/5 the cost.

Because of the long life of diamond abrasives the cost per hole of diamond abrasives is approximately 1/5 of the vitrified abrasives.

Diamond abrasives in combination with the Rottler Precision Honing Head make a very rigid honing head. The system will do an excellent job of truing tapered or out of round holes with little or no operator attention. An operator can set the roughing and finishing loads and expect the machine to hone the cylinder to size unattended with little or no attention. It is important to use proper stone pressure when using diamond abrasives. The roughing motor load setting should be in the 0 - 60% range. The finishing load should be set in the 15 – 25% area. Generally, the higher the roughing motor load reading the faster the stock removal. The lower the finishing load is set, the more accurate the bore will be.

The H75X is capable of removing an unlimited amount of material from a cylinder with a high degree of accuracy. Generally, it is desirable for overall engine block geometry to use a boring machine to bore all material out except for .003 of hone stock.

It is important to use Rottler Synthetic Coolant, part number 514-4-71C, when using diamond stones. It must be mixed with water and maintained properly to give optimum honing results.

**Note:** When mounting new stones in holders it is recommended that you flat stone the back of the stones to remove any possibility of burrs causing misalignment of stones mounted in holders.

### **Scratching**

Scratching in the cylinder looks as though a single grit of a larger abrasive particle has lodged between the cylinder wall and the hone head. Often the scratch will be less than one revolution of the hone head and it will follow the cross hatch angle of the honing machine. Several things can cause this problem.

### **Improper coolant mix**

The ratio of water to synthetic additive to water will change after the initial mix is put in the coolant tank. A Refractometer can be purchased to accurately check the ratio. When the ratio is measured as a percentage it should be 5 – 8%. This corresponds to a reading of 3-5 on the Refractometer. It is important not to confuse the percentage with the true Refractometer reading.

Unacceptable synthetic coolant brand.

Lack of abrasive dressing.

Dirty Coolant.

### **Breaking In A New Set of Diamond Abrasives**

Rottler diamond abrasives are pre-radiuses to minimize the breaking in period. When a new set of diamonds is installed the surface finish obtained on the first few blocks will be 5-10 Ra rougher than after the break in period. You must hone 2 - 5 blocks before the surface finish stabilizes.

### **Dressing Diamond Abrasives**

Diamond Abrasives use a metal bond to hold the individual diamond particles. Failing to dress the stones after honing 30 - 50 blocks will increase the pressure required to remove stock or the stock removal rate slows down significantly. This will result in finishes with excessive folded and torn metal. Undressed stones will also cause excess bore distortion and inaccuracies in the boring process. This is caused by the diamond abrasive dulling or the bond not breaking down. The edge of the stone will also become very sharp. This is a normal occurrence and is easily corrected by removing the holder/abrasive assembly, use a wire brush to dress the abrasive. A common method is to remove the stone holder from the hone head. Leave the stone in the stone holder and move the stone through a bench grinder wire wheel. The brush rotation should be across the narrow width of the stone. Turn the holder over and pass the stone through the wheel again. This process will return the abrasive to a like new cutting condition, and put a slight radius on the edge of the abrasive stick (approx. .005 inch.)

### **Torn Metal**

This is often caused by improper coolant mix, lack of dressing, or the use of high honing pressure during the finishing process. The Rottler hone head is capable of very high loads. If problems with torn metal are encountered verify the coolant mix, proper dressing of the abrasives, and reduce the finishing load during the final hone stage. If required make several strokes manually with minimum stone pressure (1020%).

**Stock Removal Rate**

The hardness of the cylinder you are honing will affect the stock removal rate. If you find the stock removal rate for a given cylinder is slower than normal check to make sure you have properly dressed the stones. Improperly dressed stones can increase honing time by as 50% or more. Improperly dressed stones will also produce an unacceptable finish.

**Diameter Range**

Because the diamond abrasives break down very slowly, a single set of stones is limited in its diameter range. One set of diamonds should be used for each stone holder range. A set of diamonds can not be constantly changed from one stone holder size to another. The stones would constantly be in the breakin process and very poor performance or finishes will result.

**Cross Hatch Angle and Washout**

The ideal situation would be for a hone to change the direction it is traveling instantaneously. If this was possible the angle of the cross hatch would stay consistent through the entire cylinder. The Rottler H75X uses high speed electronics in cooperation with a ballscrew drive to change the direction of travel. This reduces the amount of Cross Hatch wipeout considerably from a crank driven rocker arm. As a rocker arm changes direction, the rate of travel slows but the rotation speed of the hone head stays consistent. This is the cause of washout at the top and bottom of cylinders. Since the H75X has a linear travel spindle this condition does not exist.

**Coolant****Coolant types and Selection**

When using Vitrified honing stones you must use a petroleum based coolant. Such as Mobil Met 33 or Upsilon or any equivalent light honing oil. This is required since vitrified honing stones are not compatible with water based synthetic coolants.

Diamond stones will work with oil or water based synthetic coolants, but work most efficiently with the water based synthetic coolants. Rottler Manufacturing recommends the use of Rottler 514-4-71C water based, synthetic coolant for diamond only applications. This coolant works best when mixed to a 5% – 8% solution.

**Refractometer**

A Refractometer is used to measure the amount of coolant to water ratio. A 5% to 8% ratio will read a 3 – 5 on the Refractometer. It is important not confuse the ratio with the actual Refractometer reading.

Coolant to Water Ration is 1:20 thus 1 gallon of coolant to 20 gallons of water.

**Coolant Pump System**

The coolant tank on the H75X will hold a maximum of 70 gallons of the selected coolant. Unless an Auxiliary tank is purchased, which will increase the capacity to 120 gallons.

## Honing of Alusil, Silitec, and Lokasil Materials

These instructions are for honing Alusil and Lokasil materials with Rottler H75X honing machine and water base coolant.

### Equipment and parts needed

**Machine:** Rottler H75X

**Coolant:** Rottler part# 514-4-71C

**Hone Head:** Rottler part# 514-9B

**Stone Holders:** Rottler parts determined by size of bore

**Abrasives:** Rottler 400 grit diamonds part# 514-9-14V (do not substitute different grit size)

KS finishing diamonds Rottler part# 514-9-18P

KS silicon exposing stones Rottler part# 514-9-18N.

Alternative to exposing stones is felt wipers and silicon compound. Rottler part# for felt wipers 514-9-21E. Rottler part# for silicon compound 514-9-21F

### Instructions for Honing Alusil and Lokasil Cylinders

Cylinders should be bored to within .002 with a PCD insert. This is very important to prevent fracturing of silicon particles below the finish surface of bore. If PCD isn't used the exposure of the silicon will result in a defective sliding surface for piston and rings.

**\*NOTE: When using the diamond stones they should be trued in to diameter of cylinder by using them in cast iron cylinder the same diameter of aluminum cylinder being honed. This includes the KS finish diamonds also.**

Cylinders should then be honed on H75X using Rottler 400 grit diamond stones (no substitutes only use 400 grit) to size with tolerance of +.0002 -.0000. Machine parameters should be set as follows: RPM 200 to 225, Honing loads should be set at 20% to 25% for roughing and 15% finish load.

Next install the KS finishing diamonds and run one cycle in the plateau mode. The plateau mode parameters for the H75X hone are normally 20% load and 7 strokes per cycle. You will need to change these parameters (see operating instructions) to 10 strokes per cycle and a honing load of 15%. Cylinders should already be to size from previous step. You are not trying to remove much material with this operation. The need for this operation is to lower the surface finish for the next step.

**\*NOTE: Chamfer or break the edge of the exposing stones prior to using them in bore. This will help prevent chipping on stone edges.**

The last step in the process is to expose the silicon particles by eroding the surrounding metal away from the silicon particles. This can be accomplished with different methods. The first method (easiest and cleanest) is to use the exposing stones part# 514-918N. These stones will need to be installed in machine and run for two plateau cycles. The plateau cycles should be same as prior step (10 strokes and 15% honing load). The bores should be flushed with coolant after the first plateau cycle and then second cycle run. It is extremely important that during this last stage that operator not force exposing stones into cylinders. Operator should start stones slightly away from cylinder wall and let machine feed stones into cylinder wall at the 15% honing load specified. These stones are extremely soft and any forcing of stones into cylinder wall will shorten stone life.

The second method to exposing the silicon particles is to use Rottler part# 514-9-21E. These are a felt wiper that is used with Rottler part# 514-9-21F which is a silicon compound paste. When using this method the coolant will need to be shutoff. Take a small paint brush and apply paste to felt wipers and the entire cylinder. Install hone head in bore, hone for approximately 45 to 60 seconds per cylinder. Machine settings for this operation should be RPM 160 to 170, strokes per minute of 60, shut-off automatic stone feed up. Start machine and feed stones up manually until load reaches 15%. Let



machine run for 45 to 60 seconds per cylinder. Reapply silicon compound to each cylinder. There is no need to over stroke cylinder during this process so shorten stroke length accordingly.

For honing the Lokasil and Alusil cylinders the preferred method is the use of exposing stones; however the other method will work.

### **When Honing Silitec Cylinders**

When honing Silitec cylinders use the above method of boring and honing cylinders. When removing metal away from silicon particles the second method of silicon paste and felt wipers must be used for Silitec cylinders only.

## **Honing a Cylinder Block**

### **Introduction**

The purpose of this section is to familiarize the operator with various features of the H75X.

The operator should have a working knowledge of honing and be familiar with using a power hone.

It is suggested that scrape block be used for the following walk-through.

### **Definitions of terms used in this section:**

**Button:** A labeled icon on the control display screen.

**Touch:** To activate an icon button we will use the term touch. ie: Touch CYCLE START button to start the programed honing process. Some buttons will stay active once they have been touched and must be touched a second time to deactivate.

**Touch and Hold:** Some buttons are momentary buttons and you must maintain contact with the button to keep it active. ie: When the Z- button is touched and contact maintained the hone head will travel downward until contact with the button is released.

**Value Box:** A small box section of the screen that contains a number that indicates a value for the function listed next to it.

### **Safety Reminders:**

When machine is idle the spindle should always be keep in the full up position and the E-STOP engaged. This deactivates touchscreen controls to prevent any accidental activation. The word E-STOP IN will be displayed on the red Stop Machine button at the lower left corner of the operation screen

The operator can stop the honing process at any time by touching the STOP MACHINE button. Touching the CYCLE START button again will restart the process.

If an emergency situation arises or if the touchscreen is not responding, pressing the E-STOP button will shut off power to all motors and solenoids and bring the hone to a stop. The word E-STOP IN will be displayed on the Stop Machine button. To release the E-STOP turn the button clockwise until it pops out.

## Getting Started

Once the machine is set up and ready to run turn on power to machine by flipping the power switch to the on position.



It will be assumed that the machine is being operated without a keyboard or mouse attached.

The computer will start up and boot screen will appear on the monitor. This may take a few minutes if operating system is doing an update.

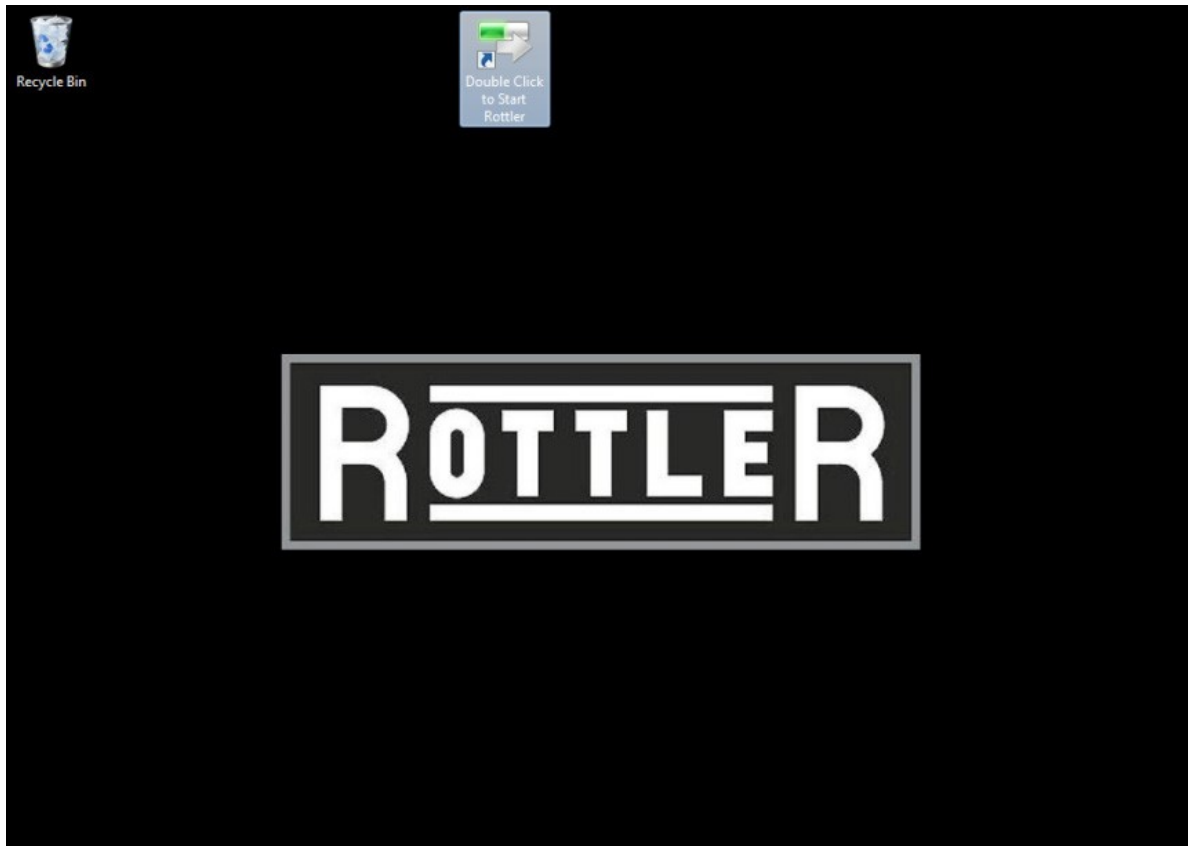

Double Touch the Start Rottler icon. The HOME screen will appear on the monitor.



This is the Home screen. Using the jog buttons touch the X+ button to move the carriage to the right side of the machine. Touch the Z+ button to raise the spindle all the way to the top. Now the machine is in its block loading position. Engage the E-STOP by pressing the red E-STOP switch.



The Stop Machine button now reads E-STOP IN. It is now safe to work inside the tank area.

## Planning the Job

### Block Specifications

You will need to know the following information for the job you are planning:

- Finish bore size, cross hatch angle, and finish.
- Bore length.
- Center to center dimension of cylinders.
- If the job is a V type block, the pan rail to crank line center dimension, and cylinder offset between cylinder banks.

### Riser Block Selection

When honing a V type engine block on the H70 series machines it is important that the block be correctly located so that the hone head is centered in the bore. Various engines all have different dimensions for pan rail to crank center line. Since the pan rails are the locating surface for the H70

series machines it is essential that spacers be used under the pan rails in order to locate the crank centerline in the ideal location.

In order to determine which spacer set is required you will need to know the pan rail to crank center line distance. Once that is known you will have to choose the spacer that will give you the dimension that is as close to 4.50"(114mm) as possible.

**For example:**

You have a Chevy LS1 block. If you measure the pan rail to crank center line distance you will come up with 2.60"(66mm). Take that dimension and subtract it from 4.50"(114mm) and you end up with dimension of 1.90"(48mm). Looking at the chart below you will find that the 514-7-15E spacer set will give you the ideal crank center line location.

Sets of parallels				
Parallel #	Part #	Height 1	Height 2	Height 3
1	514-7-15A	0.9(23mm)	1.5(38mm)	4.0(102mm)
2	514-7-15B	1.0(25mm)	1.6(41mm)	4.1(104mm)
3	514-7-15C	1.1(28mm)	1.7(43mm)	4.2(107mm)
4	514-7-15D	1.2(30mm)	1.8(46mm)	4.3(109mm)
5	514-7-15E	1.3(33mm)	1.9(48mm)	4.4(112mm)
6	514-7-15F	1.4(36mm)	2.0(51mm)	4.5(114mm)

Attach the 514-7-15E spacers to the parallel cross supports and place them on the block fixture. Note on the chart above that 1.90"(66mm) dimension is located in the Height 2 column. The Height columns tell you which mounting surface of the parallels are used for that particular combination. See illustration below for Height locations on the parallels.

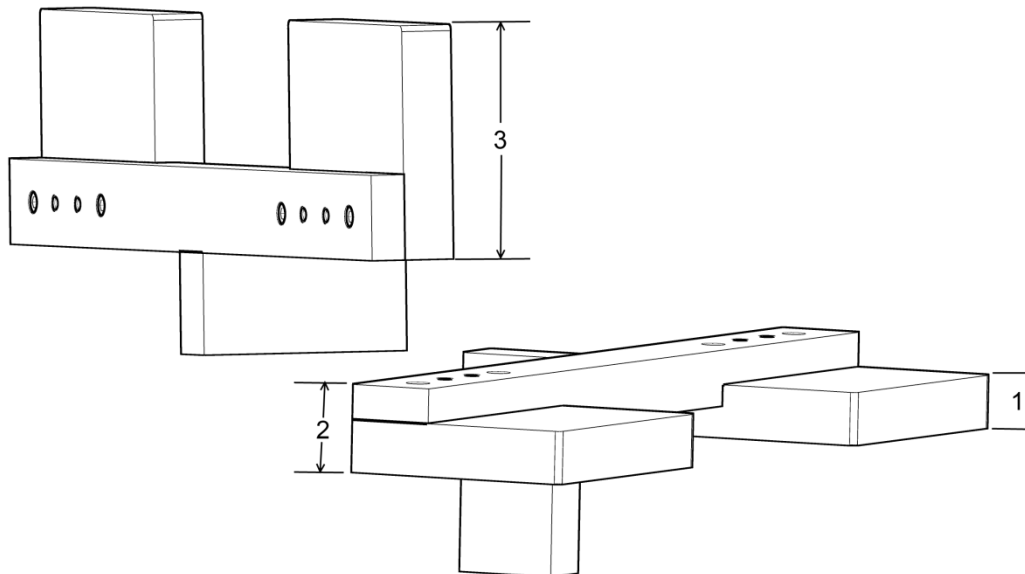

When the block is placed in the fixture make sure that the pan rails are sitting on the surface of parallel that is called for. In this instance Height 2 was called for so the pan rails of the block will sit on the surface that includes the spacer and the cross support.

Below is a chart of some common engine pan rail to crank center line dimensions and the spacer combinations for those. The Parallel # column is referring to the same column on the previous chart for spacer dimensions.

<b>Engine Pan to Main bearing Measurements</b>			
Engine	Bore to Pan Dist.	Parallel Height	Parallel #
Chrysler V10	3.50(89mm)	1.00(25mm)	2
Powerstroke	3.35(85mm)	1.15(29mm)	3
	3.35(85mm)	1.15(29mm)	3
Duramax	3.10(79mm)	1.40(36mm)	6
Big Block Chrysler	3.00(76mm)	1.50(38mm)	1
Triton V10	3.00(76mm)	1.50(38mm)	1
3.0 & 3.4 Toyota	2.90(74mm)	1.60(41mm)	2
430 Lincoln	2.80(71mm)	1.70(43mm)	3
Ford FE block	2.70(69mm)	1.80(46mm)	4
	2.65(67mm)	1.85(47mm)	4
LS	2.60(66mm)	1.90(48mm)	5
3.3 Chrysler	2.60(66mm)	1.90(48mm)	5
3.0 Mitsubishi	0.40(10mm)	4.10(104mm)	2
	0.39(10mm)	4.11(104mm)	2
Oldsmobile 330-455	0.25(6mm)	4.25(108mm)	3
Chev 2.8-3.1	0.25(6mm)	4.25(108mm)	3
351 Cleveland	0.13(3mm)	4.37(111mm)	5
Small Block Chev	0.13(3mm)	4.38(111mm)	5
Big Block Chev	0.13(3mm)	4.38(111mm)	5
6.5 Chev diesel	0.13(3mm)	4.38(111mm)	5
351	0.13(3mm)	4.38(111mm)	5
GM 4.3	0.12(3mm)	4.38(111mm)	5
Buick 350, 401, 455	0.12(3mm)	4.38(111mm)	5
Pontiac	0.00	4.50(114mm)	6

### Tooling Selection

You will need to decide what honing process will be used and if there will be a final plateau process for the job. Based on that decision use the following charts to select which hone head, stone holders, stones, and if need brushes.

Now is also a good time to set your bore gauge to desired final size.

**STONE HOLDER SIZE CHART H70 SERIES**  
**MEDIUM HONE HEAD 514-10-20**

Diameter (New Stones) Inches				
	0.312	Stones	0.2	Stones
	Min	Max	Min	Max
514-13-13A	2.34	2.45	2.12	2.23
514-10-13B	2.54	2.65	2.32	2.43
514-10-13C	2.74	2.85	2.52	2.63
514-10-13D	2.94	3.05	2.72	2.83
Diameter (New Stones) (Metric)				
	7.9248	Stones	5.08	Stones
	Min	Max	Min	Max
514-13-13A	59.44	62.23	53.75	56.54
514-10-13B	64.52	67.31	58.83	61.62
514-10-13C	69.60	72.39	63.91	66.70
514-10-13D	74.68	77.47	68.99	71.78
Diameter (New Brushes ) Inches				
	0.55	Stones	0.395	Stones
	Min	Max	Min	Max
514-13-13A	2.82	2.93	2.51	2.62
514-10-13B	3.02	3.13	2.71	2.82
514-10-13C	3.22	3.33	2.91	3.02
514-10-13D	3.42	3.53	3.11	3.22
Diameter (New Brushes) (Metric)				
	13.97	Stones	10.033	Stones
	Min	Max	Min	Max
514-13-13A	71.53	74.32	63.65	66.45
514-10-13B	76.61	79.40	68.73	71.53
514-10-13C	81.69	84.48	73.81	76.61
514-10-13D	86.77	89.56	78.89	81.69

**LARGE HONE HEAD 514-9G**

Diameter (New Stones) Inches				
	0.312	Stones	0.2	Stones
	Min	Max	Min	Max
514-9-5J	2.99	3.45	2.77	3.23
514-9-5A	3.17	3.63	2.94	3.41
514-9-5B	3.42	3.88	3.19	3.66
514-9-5C	3.67	4.13	3.44	3.91
514-9-5D	3.92	4.38	3.69	4.16
514-9-5E	4.17	4.63	3.94	4.41
514-9-5F	4.42	4.88	4.19	4.66
514-9-5G	4.67	5.13	4.44	4.91
514-9-5H	4.92	5.38	4.69	5.16
514-9-5K	5.17	5.63	4.94	5.41
514-9-5L	5.42	5.88	5.19	5.66
514-9-5M	5.67	6.13	5.44	5.91
514-9-5N	5.92	6.38	5.69	6.16
514-9-5P	6.17	6.63	5.94	6.41
514-9-5Q	6.42	6.88	6.19	6.66
514-9-5R	6.67	7.13	6.44	6.91
514-9-5S	6.92	7.38	6.69	7.16
Diameter (New Stones) (Metric)				
	7.9248	Stones	5.08	Stones
	Min	Max	Min	Max
514-9-5J	75.92	87.73	70.23	82.04
514-9-5A	80.39	92.20	74.70	86.51

514-9-5B	86.74	98.55	81.05	92.86
514-9-5C	93.09	104.90	87.40	99.21
514-9-5D	99.44	111.25	93.75	105.56
514-9-5E	105.79	117.60	100.10	111.91
514-9-5F	112.14	123.95	106.45	118.26
514-9-5G	118.49	130.30	112.80	124.61
514-9-5H	124.84	136.65	119.15	130.96
514-9-5K	131.19	143.00	125.50	137.31
514-9-5L	137.54	149.35	131.85	143.66
514-9-5M	143.89	155.70	138.20	150.01
514-9-5N	150.24	162.05	144.55	156.36
514-9-5P	156.59	168.40	150.90	162.71
514-9-5Q	162.94	174.75	157.25	169.06
514-9-5R	169.29	181.10	163.60	175.41
514-9-5S	175.64	187.45	169.95	181.76

Diameter (New Brushes ) Inches				
	0.55	Stones	0.395	Stones
	Min	Max	Min	Max
514-9-5J	3.47	3.93	3.16	3.62
514-9-5A	3.64	4.11	3.33	3.80
514-9-5B	3.89	4.36	3.58	4.05
514-9-5C	4.14	4.61	3.83	4.30
514-9-5D	4.39	4.86	4.08	4.55
514-9-5E	4.64	5.11	4.33	4.80
514-9-5F	4.89	5.36	4.58	5.05



514-9-5G	5.14	5.61	4.83	5.30
514-9-5H	5.39	5.86	5.08	5.55
514-9-5K	5.64	6.11	5.33	5.80
514-9-5L	5.89	6.36	5.58	6.05
514-9-5M	6.14	6.61	5.83	6.30
514-9-5N	6.39	6.86	6.08	6.55
514-9-5P	6.64	7.11	6.33	6.80
514-9-5Q	6.89	7.36	6.58	7.05
514-9-5R	7.14	7.61	6.83	7.30
514-9-5S	7.39	7.86	7.08	7.55
Diameter (New Brushes) (Metric)				
	13.97	Stones	10.033	Stones
	Min	Max	Min	Max
514-9-5J	88.01	99.82	80.14	91.95
514-9-5A	92.48	104.29	84.61	96.42
514-9-5B	98.83	110.64	90.96	102.77
514-9-5C	105.18	116.99	97.31	109.12
514-9-5D	111.53	123.34	103.66	115.47
514-9-5E	117.88	129.69	110.01	121.82
514-9-5F	124.23	136.04	116.36	128.17
514-9-5G	130.58	142.39	122.71	134.52
514-9-5H	136.93	148.74	129.06	140.87
514-9-5K	143.28	155.09	135.41	147.22
514-9-5L	149.63	161.44	141.76	153.57
514-9-5M	155.98	167.79	148.11	159.92

514-9-5N	162.33	174.14	154.46	166.27
514-9-5P	168.68	180.49	160.81	172.62
514-9-5Q	175.03	186.84	167.16	178.97
514-9-5R	181.38	193.19	173.51	185.32
514-9-5S	187.73	199.54	179.86	191.67

**EXTRA LARGE HONE HEAD 514-9D**

Diameter (New Stones) Inches				
	0.312	Stones	0.2	Stones
	Min	Max	Min	Max
514-9-24A	6.24	6.43	6.02	6.21
514-9-24B	6.44	6.63	6.22	6.41
514-9-24C	6.74	6.93	6.52	6.71
514-9-24D	7.04	7.23	6.82	7.01
514-9-24E	7.34	7.53	7.12	7.31
514-9-24F	7.64	7.83	7.42	7.61
514-9-24G	7.94	8.13	7.72	7.91
514-9-24H	8.24	8.43	8.02	8.21
514-9-24J	8.54	8.73	8.32	8.51
514-9-24K	8.84	9.03	8.62	8.81
514-9-24L	9.14	9.33	8.92	9.11
514-9-24M	9.44	9.63	9.22	9.41
514-9-24M	11.02	11.21	10.80	10.99
514-9-24P	11.79	11.98	11.57	11.76
Diameter (New Stones) (Metric)				
	7.9248	Stones	5.08	Stones
	Min	Max	Min	Max

514-9-24A	158.50	163.32	152.81	157.63
514-9-24B	163.58	168.40	157.89	162.71
514-9-24C	171.20	176.02	165.51	170.33
514-9-24D	178.82	183.64	173.13	177.95
514-9-24E	186.44	191.26	180.75	185.57
514-9-24F	194.06	198.88	188.37	193.19
514-9-24G	201.68	206.50	195.99	200.81
514-9-24H	209.30	214.12	203.61	208.43
514-9-24J	216.92	221.74	211.23	216.05
514-9-24K	224.54	229.36	218.85	223.67
514-9-24L	232.16	236.98	226.47	231.29
514-9-24M	239.78	244.60	234.09	238.91
514-9-24M	279.91	284.73	274.22	279.04
514-9-24P	299.47	304.29	293.78	298.60

Diameter (New Brushes ) Inches				
	0.55	Stones	0.395	Stones
	Min	Max	Min	Max
514-9-24A	6.72	6.91	6.41	6.60
514-9-24B	6.92	7.11	6.61	6.80
514-9-24C	7.22	7.41	6.91	7.10
514-9-24D	7.52	7.71	7.21	7.40
514-9-24E	7.82	8.01	7.51	7.70
514-9-24F	8.12	8.31	7.81	8.00
514-9-24G	8.42	8.61	8.11	8.30
514-9-24H	8.72	8.91	8.41	8.60
514-9-24J	9.02	9.21	8.71	8.90
514-9-24K	9.32	9.51	9.01	9.20

514-9-24L	9.62	9.81	9.31	9.50
514-9-24M	9.92	10.11	9.61	9.80
514-9-24M	11.50	11.69	11.19	11.38
514-9-24P	12.27	12.46	11.96	12.15
Diameter (New Brushes) (Metric)				
	13.97	Stones	10.033	Stones
	Min	Max	Min	Max
514-9-24A	170.59	175.41	162.71	167.54
514-9-24B	175.67	180.49	167.79	172.62
514-9-24C	183.29	188.11	175.41	180.24
514-9-24D	190.91	195.73	183.03	187.86
514-9-24E	198.53	203.35	190.65	195.48
514-9-24F	206.15	210.97	198.27	203.10
514-9-24G	213.77	218.59	205.89	210.72
514-9-24H	221.39	226.21	213.51	218.34
514-9-24J	229.01	233.83	221.13	225.96
514-9-24K	236.63	241.45	228.75	233.58
514-9-24L	244.25	249.07	236.37	241.20
514-9-24M	251.87	256.69	243.99	248.82
514-9-24M	292.00	296.82	284.12	288.95
514-9-24P	311.56	316.38	303.68	308.51

### Stone and Brush Selection

Use the following charts to select the stones and brushes to obtain the desired finish

NOTE: Ra - Roughness Average. Value before Ra is in micro inches. Value in brackets um is micro meters. Long designates length of stone. Height designated thickness of stone.

	<b>Diamond Stones, .312" (7.90mm) Height</b>
514-9-14F	Diamond stones, 80 grit, 3" (76mm) long, 90Ra (2.25um), stock removal .004-.007/min.
514-9-14R	Diamond stones, 80 grit, 3 1/2" (89mm) long, 90Ra (2.25um), stock removal .004-.007/min. (.102 - .178mm)
514-9-14W	Diamond stones, 140/170 grit, 3" (76mm) long, 50-75Ra (1.25 - 1.875um)
514-9-14K	Diamond stones, 170/200 grit, 3" (76mm) long, 45-60Ra (1.125 - 1.5um)
514-9-14M	Diamond stones, 170/200 grit, 3 1/2" (89mm) long, 45-60Ra (1.125 - 1.5um)
514-9-14J	Diamond stones, 270/325 grit, 3" (76mm) long, 35-45Ra (.875 - 1.125um)
514-9-14T	Diamond stones, 270/325 grit, 3 1/2" (89mm) long, 35-45Ra (.875 - 1.125um)
514-9-14Z	Diamond Stones, 270/325 grit, 4" (102mm) long, 35-45Ra (.875 - 1.125um)
514-9-14E	Diamond stones, 325/400 grit, 3" (76mm) long, 24-30Ra (.6 - .75um)
514-9-14Q	Diamond stones, 325/400 grit, 3 1/2" (89mm) long, 24-30Ra (.6 - .75um)
514-9-14X	Diamond stones, 325/400 grit, 4" (102mm) long, 24-30Ra (.6 - .75um)
514-9-14V	Diamond stones, 400 grit, 3" (76mm) long, 15-19Ra (.375 - .475um)
514-9-14C	Diamond stones, 500 grit, 3" (76mm) long, 18-22Ra (.45 - .55um)
514-9-14P	Diamond stones, 500 grit, 3-1/2" (89mm) long, 18-22Ra (.45 - .55um)
514-9-14D	Diamond stones, 325/400 grit, 3" (76mm) long, 18-22Ra (.45 - .55um), Special required for bores under 2.990" diameter (75.94mm) .200" (5.1mm) Height
514-9-14U	Diamond stones, 500 grit, 2 1/2" (64mm) long, 18-22Ra (.45 - .55um)
514-9-14L	Diamond stones, 550 grit, 3" (76mm) long, 15-19Ra (.375 - .475um)
514-9-14N	Diamond stones, 550 grit, 3 1/2" (89mm) long, 15-19Ra (.375 - .475um)
514-9-14G	Diamond stones, 600 grit, 3" (76mm) long, 8-12Ra (.2 - .3um)
514-9-14S	Diamond stones, 600 grit, 3 1/2" (89mm) long, 8-12Ra (.2 - .3um)
514-9-21G	Diamond stones, 800 grit, 3" (76mm) long
514-9-21H	Diamond stones, 1000 grit, 3" (76mm) long
514-9-21J	Diamond stones, 1200 grit, 3" (76mm) long
	<b>Brushes for Plateau Finishing with Rottler Precision Hone Heads</b>
514-9-14H	Brushes, for Plateau Finishing, .550" (14mm) height, 3 1/2" (89mm) long, requires one or two size smaller stone holder compared to .312" (7.90mm) height diamond stone
514-9-14Y	Brushes, for Plateau Finishing, .395" (10mm) height, 3 1/2" (89mm) long, requires same or one size smaller stone holder compared to .312" (7.90mm) height diamond stone

### Loading the Block

The next step is to load the block that will be honed onto the fixture. In this tutorial the optional auto rotate fixture is shown. The block loading procedure is the same for the manual fixture.

Select the block that will be used. In this tutorial a small block V-8 will be used.

Set the riser blocks on the fixture cradle so that the pan rails are sitting on the surface that was determined to be closest to ideal.

**CAUTION** The main caps must be on when a V-Block is honed and on an Inline Block if the optional clamp arms are not be used.



Place the clamp bar tube through the main bore of the block. Be certain that the machined flats at the end of the clamp bar tube are in a vertical position.

Use an appropriate method to place the block on the riser parallels with the front of the block facing left or away from the control pendant. Take care to align the clamp tube with the receiver slots on the cradle. Once the block is sitting on the riser blocks place the clamp bar lock downs over the tube and turn the knobs until the clamp tube is secured.



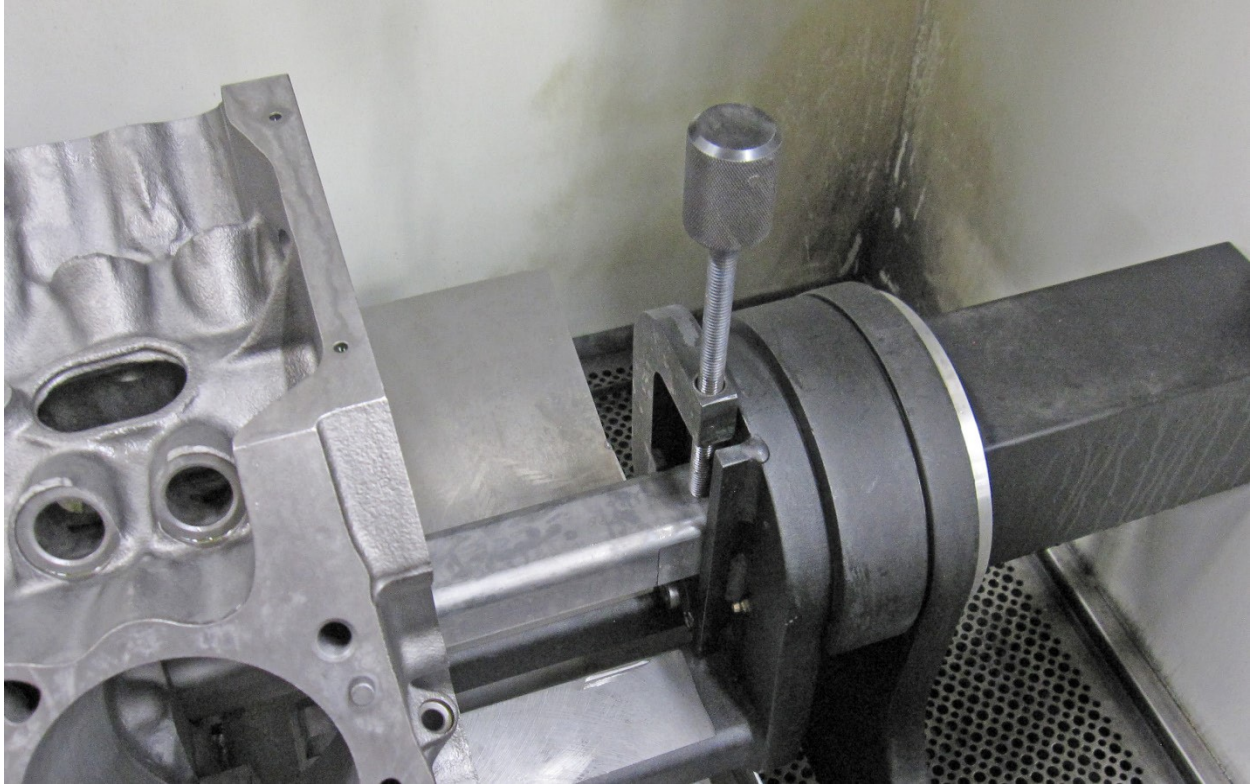

### Programing Set Up

Now that the block has been placed on the fixture and tooling has been chosen, select the stones and holders to be used in the first process. Put holders and stones into the hone head and mount hone head on spindle of machine.

The H70 series machines use a standard Kwik Switch mount system for the hone heads.



To mount a hone head confirm that the locknut is in the open position.

The hone head will have the standard locking tabs on the mounting adaptor and a drive coupler for adjusting the stones. When mounting the hone head it will be necessary to align the drive coupler with its receiver inside the drive spindle. Once they are aligned the adaptor tabs will fit into the receiver slots. The tabs will activate the release pin and the locknut will automatically turn to lock the hone head in place.

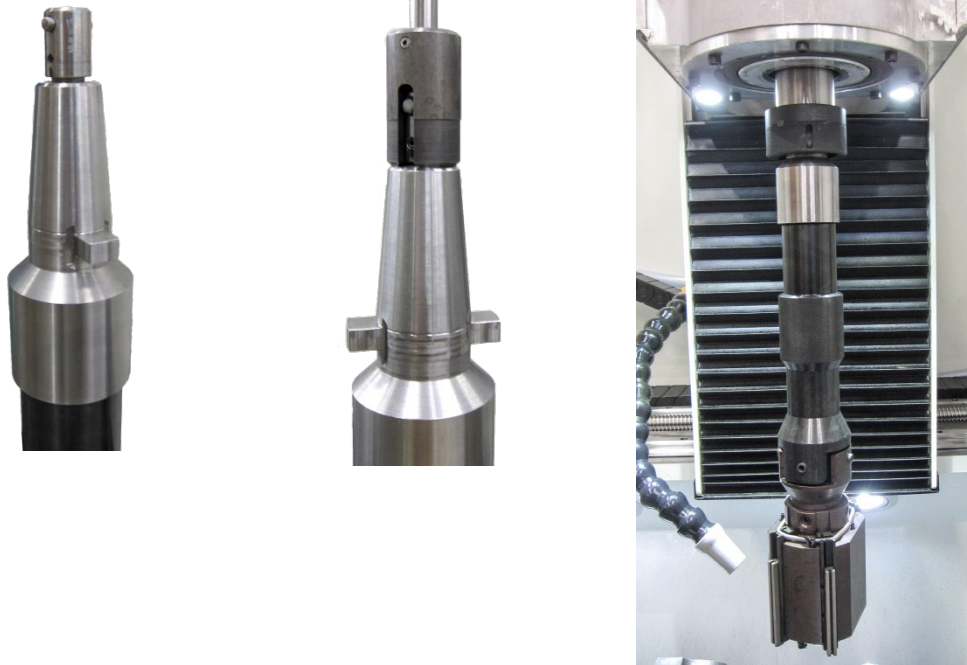

Due to design the nut will continue tighten during use. When it comes time to change or remove the hone head it may become so tight that the release wrench will be needed to loosen the locknut. Turn locknut clockwise to release the hone head.

Consult the tooling charts in the previous chapter to determine which hone head and stone holders will be needed for the job you are setting up for.

Prior to hone head installation confirm that the con rod is at least 1/4" (6mm) up inside the hone body. This will assure that the homing procedure will function correctly.

Once the hone head is attached release the E-STOP switch and touch the Home button to calibrate the hone head set up to the machine program.

Once homing is complete, check that cone rod is all the way up inside the hone head before proceeding. ***THIS IS CRITICAL.*** If for some reason the cone rod doesn't reach it's upper most travel point when homing is completed, then the bore size range will not be properly calibrated. This could result in the cone rod coming out of the hone body during operation and could potentially cause damage.



**IMPORTANT: Whenever a hone head set up is changed the machine must be Homed.**

Now that the machine is set up for honing we will construct a program to hone the block.



## Creating a Program

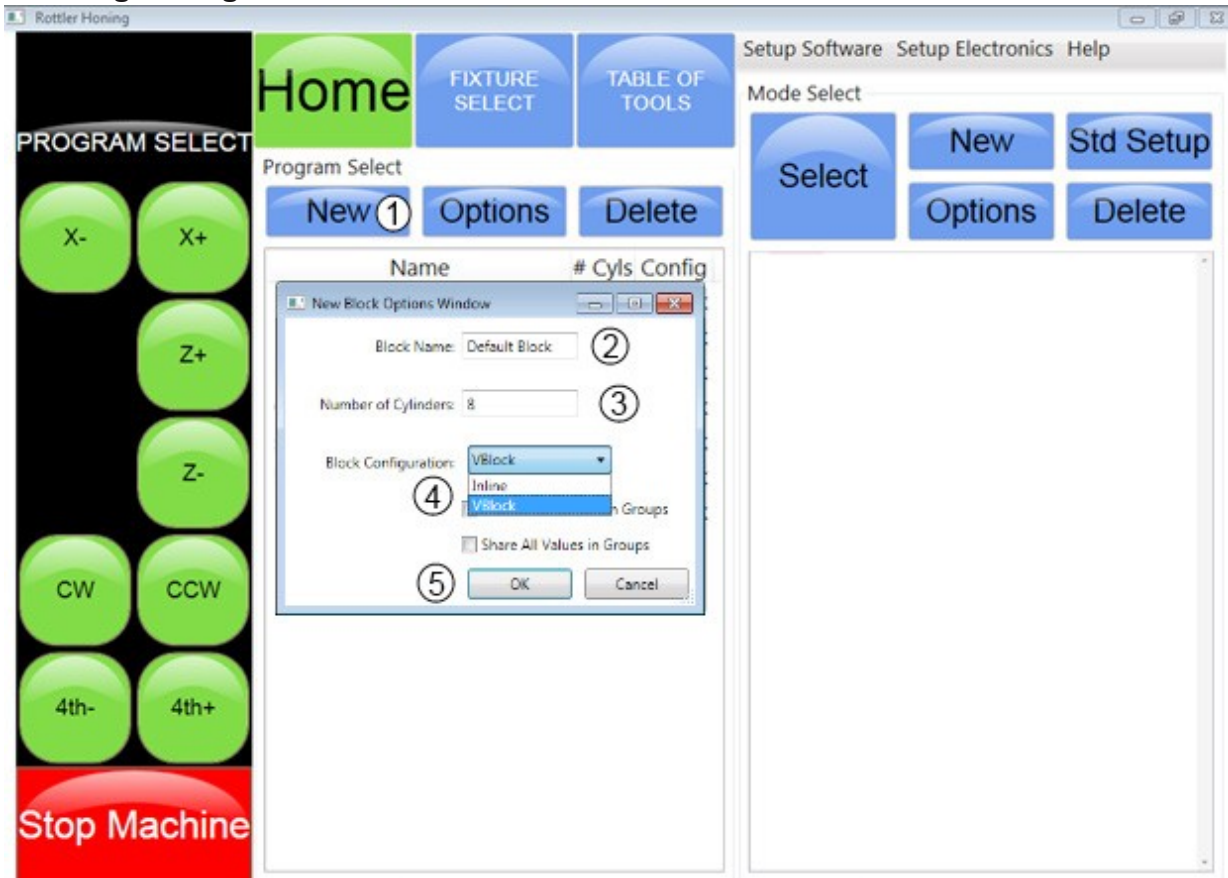

On the home screen under the Program Select touch the New button (1) and the New Block Options Window will appear.

Name the block,(2) input number of cylinders (3) and choose VBlock or Inline.(4) Touch OK (5) when finished.

The new block program title (1) will appear on the list.

For this tutorial we will use the standard Default Block and its settings.

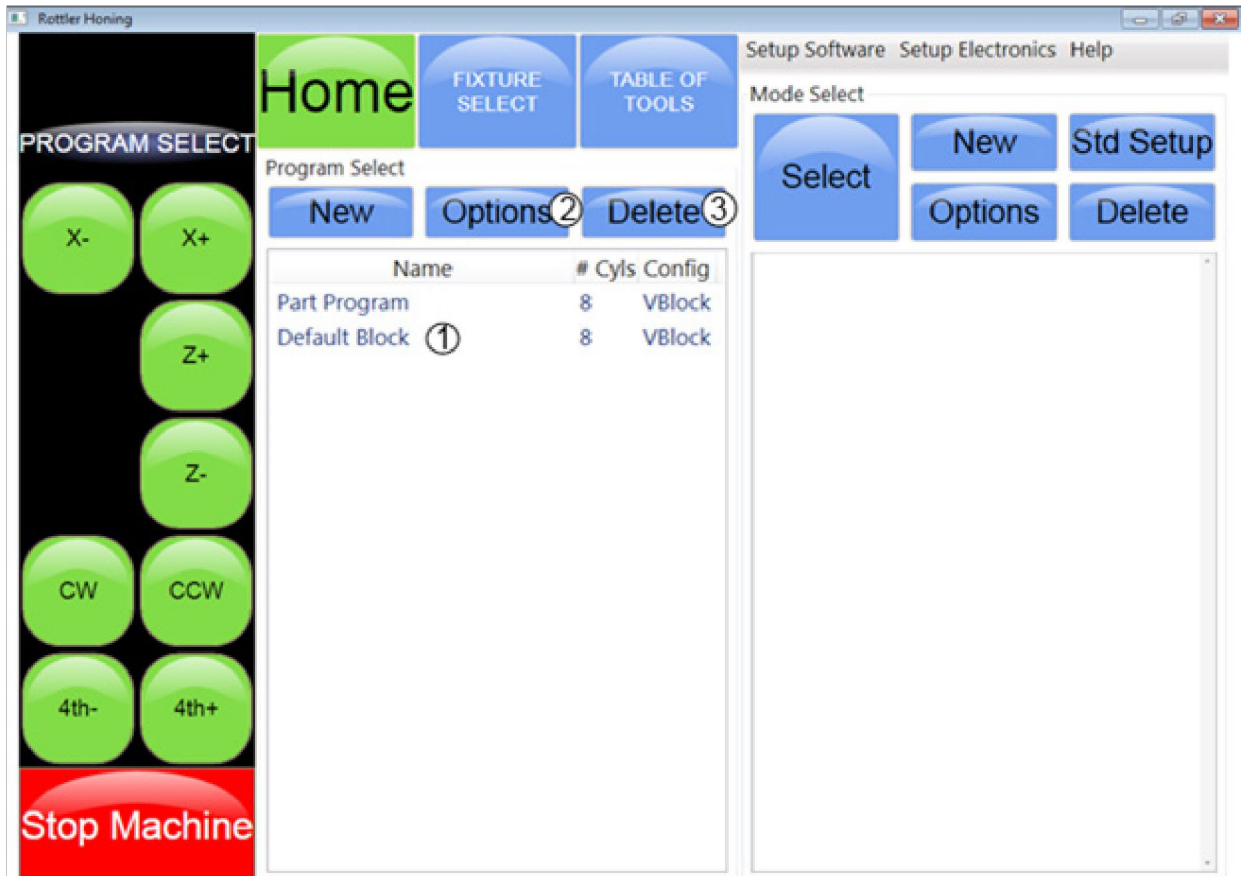

The Options button (2) will bring New Block Options Window back where you can edit information for the block that is highlighted. Highlight the block program you want to edit, then touch the Options button.

The Delete button (3) will bring up the Delete Window. (4) Highlight a block program and touch the Delete button.

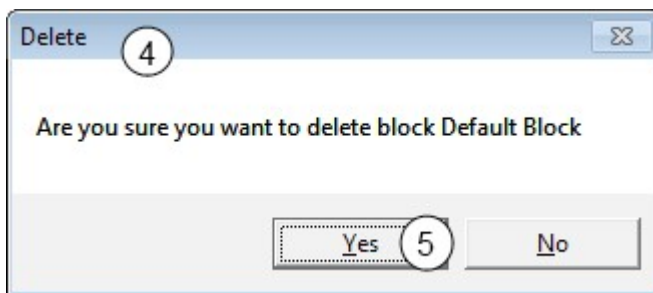

Touch the Yes button (5) if you want to delete the block that is highlighted.

### Mode Select Section of Home Screen

Click the Setup Software menu tab and this drop down menu will appear.

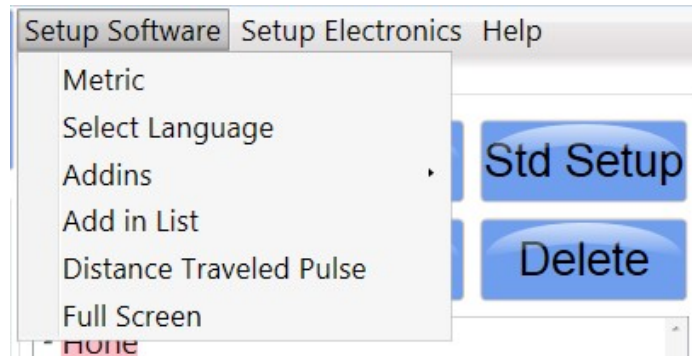

Operator should only concern themselves with the first two. Click on Metric and all readings and settings on the monitor will be metric. Uncheck Metric to return all readings and settings to inch. Click on Select Language to have everything on screen in a different language.

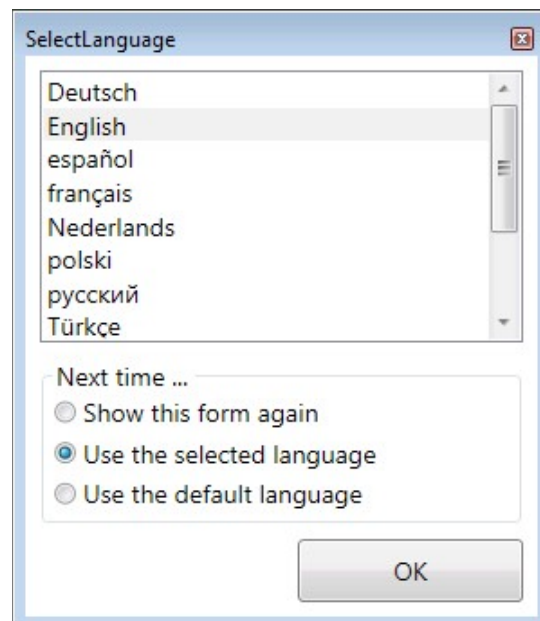
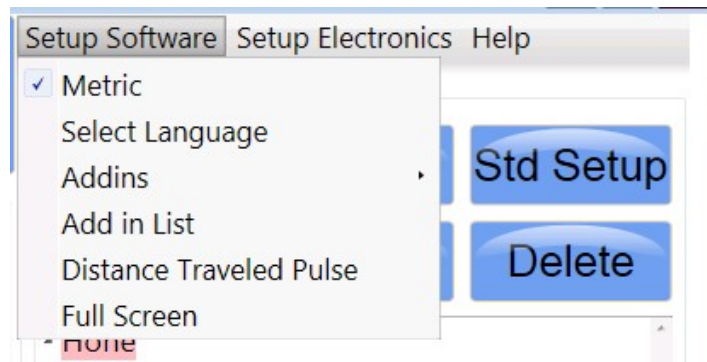

**CAUTION**

The rest of the menu items and those of the Setup Electronics tag are used only for machine setup at the factory or for use by qualified service person when needed.

Touch the New Button (1) and the New Mode Select screen (2) will appear.

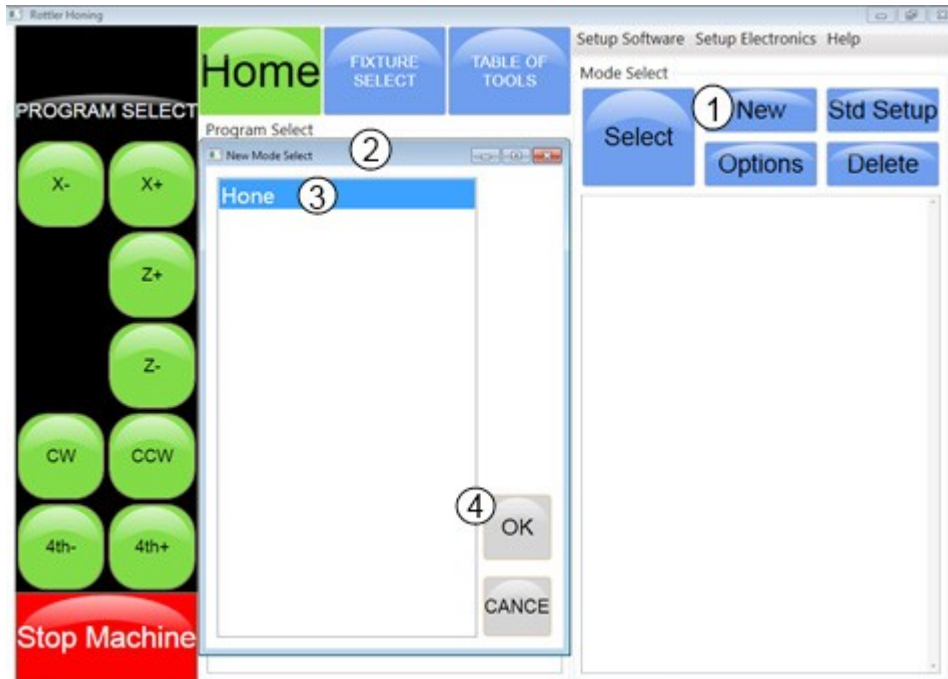

Highlight Hone (3) and touch OK.(4) The Hone program (5) will appear in the Mode Select section



Clicking the Options button (6) will bring the following window. Name of Hone process can be changed in this window.

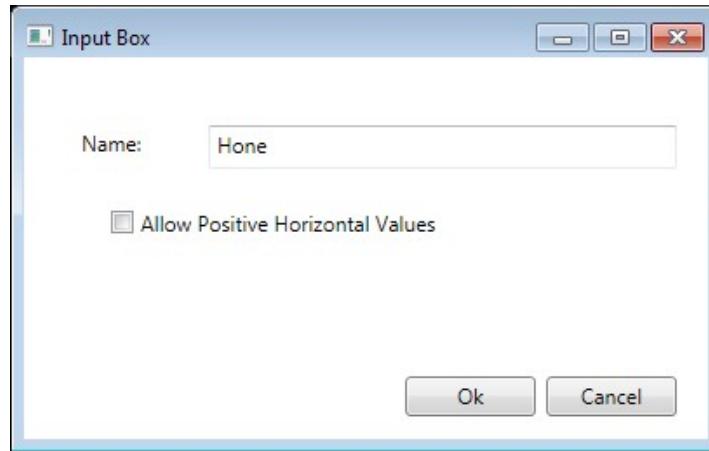

The Std Setup button (7) will bring up the following window. If you want to delete all settings in a block program that is highlighted and return the factory default setting click Yes.

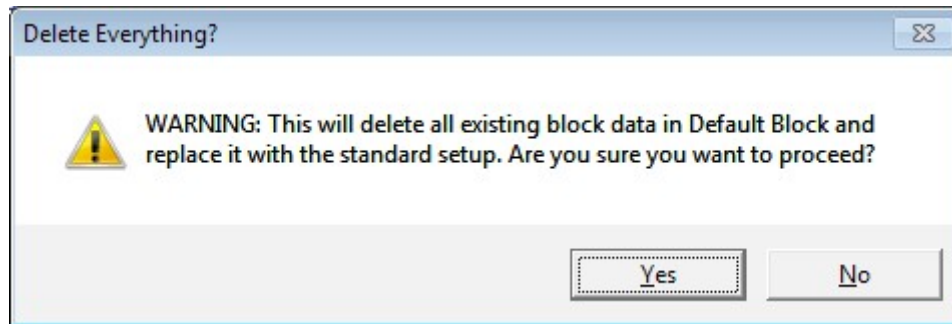

If you choose the Std Setup the following Hone Modes will be loaded onto the Mode Select screen.



Highlight the Hone (1) process for the block program you just created. If the Std Setup was chosen select either Rough Hone or Finish Hone.

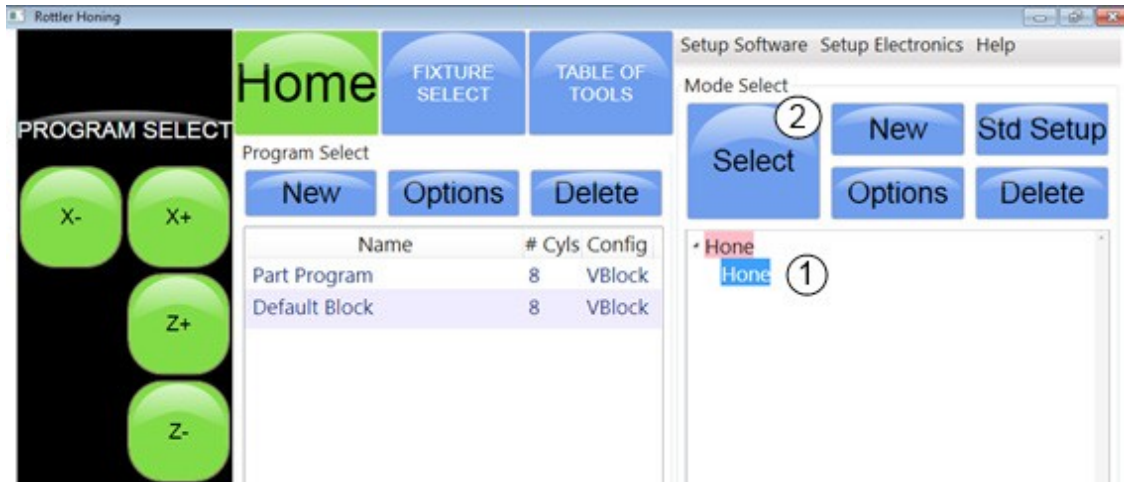

Click on the Select button (2) to bring up the Setup screen.

### Operations Setup Screen

#### Setup Tab

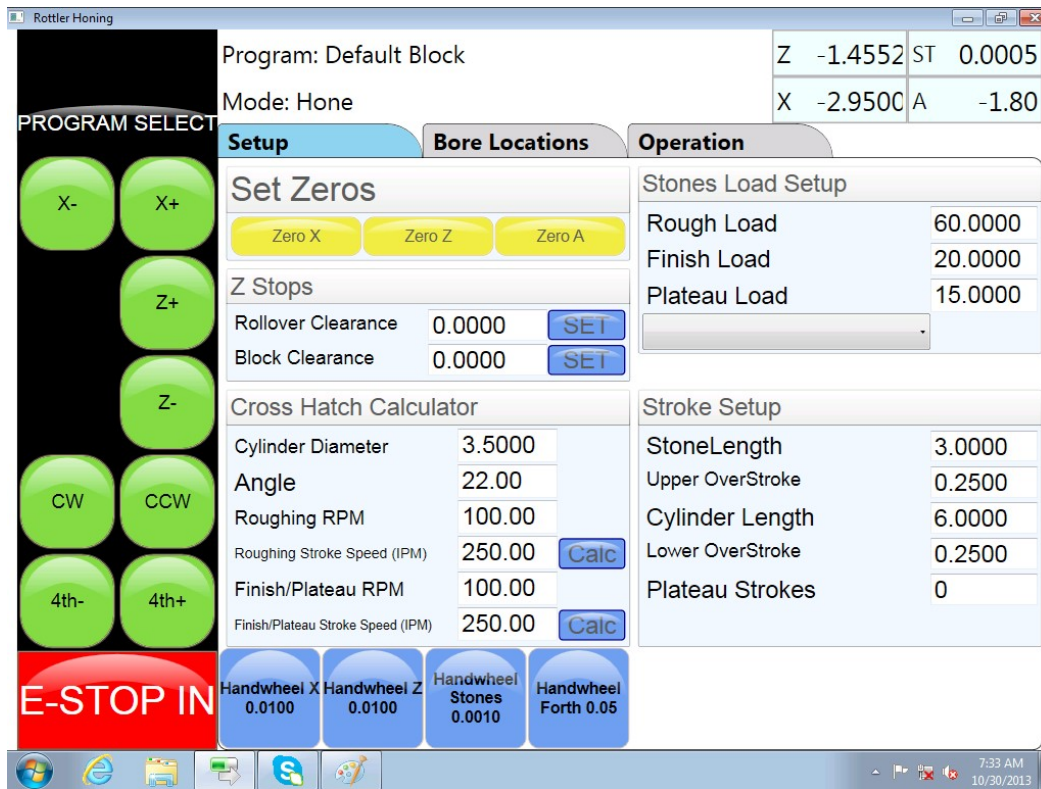

This is where machines setting are input.

Stones Load Setup	
Rough Load	20.0000
Finish Load	14.0000
Plateau Load	15.0000
large	

Begin by going to the Stones Load Setup section and inputting the values that will be used for the block you are going to hone. Touching one of the value boxes will bring up the number pad that can be used to input the value you wish to use.

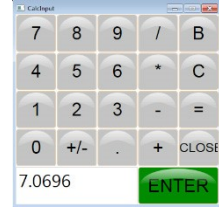

Select the hone head to be used by using the drop down menu.

Move down to the Stroke Setup section and input the values for this section. Cylinder Length is the measurement of the longest section of the cylinder. The amount of OverStroke is usually dictated by the clearance of bottom of the cylinder to the main web. When clearance is not an issue a setting of .250-.500 is a good place to start.

Stroke Setup	
StoneLength	3.0000
Upper OverStroke	0.2500
Cylinder Length	6.0000
Lower OverStroke	0.2500
Plateau Strokes	0

Cross Hatch Calculator		
Cylinder Diameter	3.5000	
Angle	22.00	
Roughing RPM	100.00	
Roughing Stroke Speed (IPM)	250.00	Calc
Finish/Plateau RPM	100.00	
Finish/Plateau Stroke Speed (IPM)	250.00	Calc

Move over to the Cross Hatch Calculator section and input the values for this section. Cylinder Diameter will be the finished size of the cylinders you are honing. Angle will be whatever angle specified by the ring manufacturer or requested by the customer. Roughing and Finish/Plateau RPM is generally set in the 120-200 range. Operator preference and experience will be the final determining factor. You can touch the Calc buttons to see what the stroke speed in IPM will be with the setting you have entered. Change the RPM setting if you think the IPM reading is either

too high or too low.

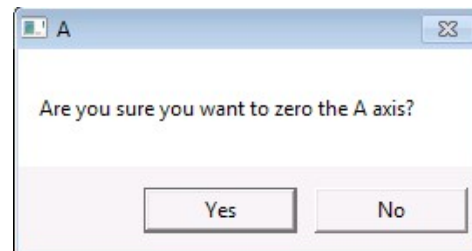

With the auto rotate fixture you will have to set the zero point. Use a level and hand controls to rotate the cradle to its zero point. Once the cradle is level touch the Zero A button, then Yes on the confirm box to set the zero point.

Now touch the Bore Locations tab (1) and the following screen will appear.

**Bore Locations Tab**

**Left Locations Sub Tab**



The first thing to do is rotate the fixture so that the left cylinder deck of the block is level. This can be done 3 different ways.

1. Touch the ROTATE button (2) and the fixture will automatically rotate to the proper position.
2. Touch the 4th + button (3) and maintain contact until the proper position is reached.
3. Touch the Handwheel Forth button (4) to activate it. The button will turn red and you can then use the handwheel to rotate the fixture into position.

**Note:** *If your machine is not equipped with the auto rotate fixture then you will simply use the handle lever to move the block from one bank to the other.*

Once the left deck is level touch the Handwheel X button (5) to activate it. Using the handwheel or X-button move the carriage until it is over the number 1 cylinder. Activate the Handwheel Z button (6) and using the handwheel lower the hone head down until the bottom is almost touching the deck. Carefully observe the position of the hone head. It should be aligned with the center of the bore. If needed the side to side position can be adjusted by activating the Handwheel X button (5) and using the handwheel to move the carriage until it is centered over the cylinder.

If the front to back position of the hone head is not centered, then that indicates that parallel setup is incorrect and must be redone in order to get the crank centerline in the proper position.



Now that the hone head is in its proper position activate the Handwheel Stones button.(7) Using the handwheel retract the stones until there is enough clearance for them to be lowered into the cylinder. Activate the Handwheel Z button (6) and using the handwheel lower the stones into the cylinder. Lower them until the top of the stones are flush with the deck.

Activate the Handwheel Stones button (7) and feed the stones out until they are almost touching the cylinder wall. Again observe the position of the hone head in relation to the center of the bore. If needed make adjustments to get the hone head as near to center as possible.

### Setting Zeros

Touch the Setup tab to bring back the Setup screen.

In the Set Zeros section touch the Zero X button and then the Zero Z button.

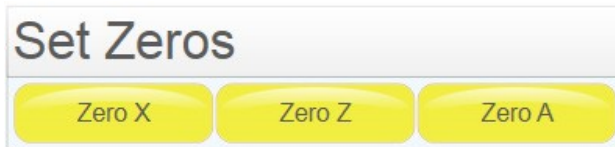

You will get a confirm pop up for each. Touch Yes to continue.

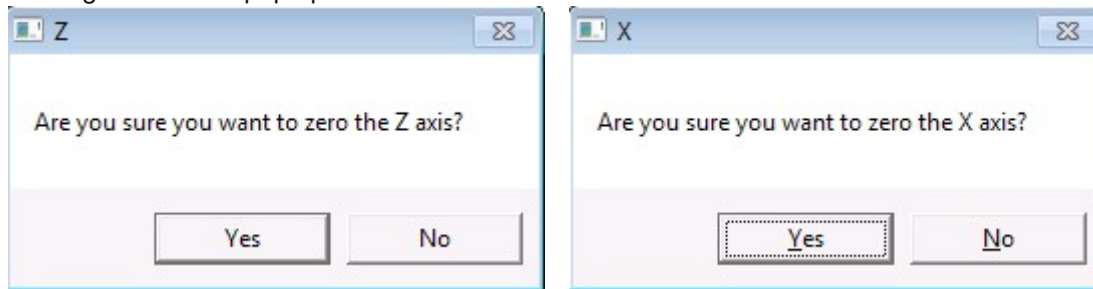

Using the handwheel raise the hone head out of the cylinder out of the bore until the bottom clears the deck by 1-2 inches. In the Z Stops section touch the SET button that is in the same line as the Block Clearance value.

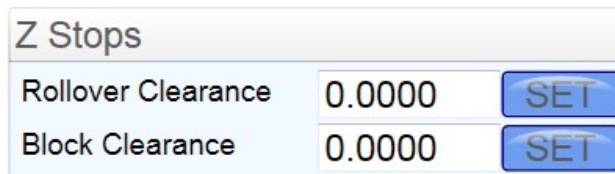

This will tell the machine how much to raise the hone head when it has completed honing a cylinder and will be moving to next during an auto cycle process. If you are honing a V type block then raise the hone head high enough to clear the block when the fixture is moved from one bank to the other. Touch the SET button that is on the same line as the Rollover Clearance value. It should look something like this.

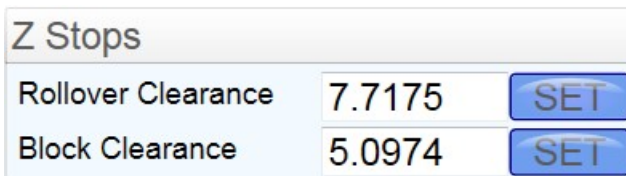

These settings also apply to the manual block fixture.

Touch the Bore Locations tab to return to the Bore Locations, Left Locations sub tab.

### Setting Bore Locations

Now the bore locations will be entered for the left bank. Location 1 under the MOVE 1 button is 0.00 since that is the zero point that you set when you set the Zero X on the Setup screen. Touch the value box (2) under the MOVE 2 button and the number pad will appear.



Enter the center to center value (2) for the block you are honing and touch ENTER.(3) In this case the center to center distance is 4.40. Continue on to the next value boxes in line and add the value to the previous setting. In this case I will add 4.40 to 4.40 to obtain 8.80 for the value box under MOVE3. Finally I will add 4.40 to 8.80 to obtain the final value under the MOVE 4 button. When completed it will look like this.



You can check your values by pressing any of the MOVE buttons. The carriage will move to the location that was touched and stop. Touch each button and visually check that the hone head is centered over the bore.

Press the Right Locations tab (1) to bring up the screen for Right Locations.

This is where you will use the bore offset dimension to calculate the bore locations for the right bank. If you do not know the bore offset dimension you can measure the width of the con rod big end and that will give you a close value for the bore offset. In this example the bore offset is .880. Enter .880 in the value box under the MOVE 1 button.(2) Note: The measurement of the width of the big end of the connecting rod only applies to engines where the two connecting rods share a common rod journal.

Continue to add the center to center value in each of the following value boxes. So in this example 4.40 will be added to .880 to obtain the value that is entered in the value box under the MOVE 2 button. When completed it will look like this.



Again verify the settings by touching each of the MOVE buttons and visually checking the location of the hone head.

On machines equipped with the auto rotate fixture touch the ROTATE button to verify that the fixture is moving to the proper bank and that deck is level. On blocks that have a bore angle other than  $90^\circ$  you will have to enter the values in the box under the ROTATE button. (3) For example if you are honing a  $60^\circ$  block you will enter -30.0 in the Right Locations section and 30.0 in the Left Locations section.

Touch the Operation tab (4) to bring up the following screen.

### Operation Tab Settings

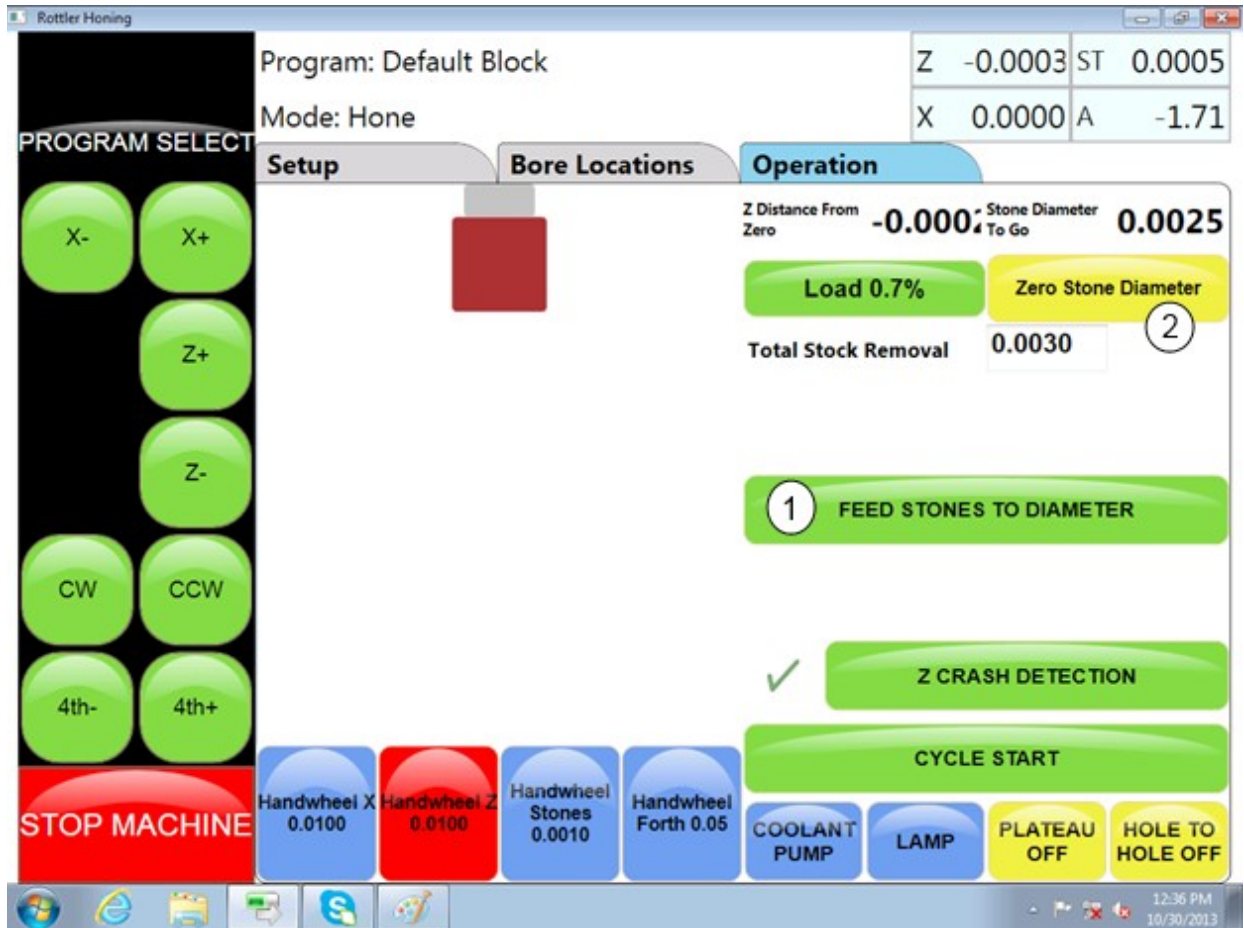

This is the screen where all honing operations take place.

The final setting is the Zero Stone Diameter. This will establish the zero point for hone stone sizing. Move the hone head over the first cylinder of the left bank. This can be done by using the handwheel, however the most accurate way to locate the hone head is to go to the Bore Locations tab and touch the MOVE 1 button. This will move the carriage to the location that is indicated on the screen. Go back to the Operation tab and lower the hone head into the cylinder until the top of the stones are below the deck. Feed the stones out using the handwheel until they are almost touching the cylinder wall.

Touch the FEED STONES TO DIAMETER button.(1) The machine will start up feed the stones out until the preset load is reached. The machine will then shut off. Touch the Zero Stone Diameter button (2) to set the zero point for stone size. Touch the Yes button on the pop up conformation.

### Setting Final Bore Size

To set the final bore size you will need to have the current and final desired bore size of the block you are honing. Use your preset bore gauge to determine how much material needs to be removed. Generally .003 is left in bored blocks to hone. In our example the final bore size will be 4.150. Current bore size is 4.147. This leaves .003 to be honed.

With the zero point set enter the amount of stock that needs to be honed to reach final size. In this example we will enter .0020 in the Total Stock Removal value box. We entered .0020 instead of .0030 in order to confirm stock removal rate for the stones being used.

Using the handwheel retract the stones a few thousandths Touch the CYCLE START button. The machine will start, the stones will feed out until the zero point is reached, then go to the bottom of the bore to check for any potential interference. If none is detected the machine will begin the honing process and continue until the amount of stock entered is removed.

When the cycle is completed the hone head will raise out of the cylinder. Move the carriage so that the bore can be checked with a bore gauge.

Note the amount still needed to be removed. In our example the reading is -0.00012 from zero. Go to the Total Stock Removal value box and enter the sum of the current value and amount still needed to be honed. In this case the new value will be 0.0032.

Go to the Bore Locations tab and touch the MOVE 2 button to locate the hone head over the next cylinder to be honed. Return to the Operation tab retract the stones slightly and lower the hone head into the cylinder. Touch CYCLE START to repeat the process done on the first cylinder.

If the bore gauge reading for cylinder 2 matches the desired final size the set up process is complete. If the size still doesn't match the final desired size repeat the process done on the second cylinder with the third cylinder. For our example we'll assume that the final size was obtained and we are ready to run the auto cycle.

Go to the Bore Locations tab and touch the HONE 2 button to deactivate it. It will turn yellow to indicate that it is inactive. The HONE 2 button is deactivated because it is already at its final size, so it doesn't need to be honed.

Return to the Operations tab and touch the HOLE TO HOLE button to activate the auto cycle process. The button will turn red and show ON to indicate that it is active.



Touch the CYCLE START button and the machine will automatically go to the first cylinder, lower the hone head into the bore, go through the setup process, then hone the cylinder to final size. After the honing is complete, the stones will be automatically retracted, the hone head will raise out of the cylinder, and move to the next cylinder and repeat the process. In this case since cylinder 2 is not active the carriage will move to cylinder 3.

When the 4th cylinder is completed the hone head will raise to the rollover clearance height, the fixture will rotate to the other bank, and the 4 cylinders on that bank will be honed.

After the final cylinder is honed the hone head will raise out of the block and the auto cycle will be complete.

If a two-step process is being used, the hone stones will now be changed and the entire process that was just completed will be repeated.

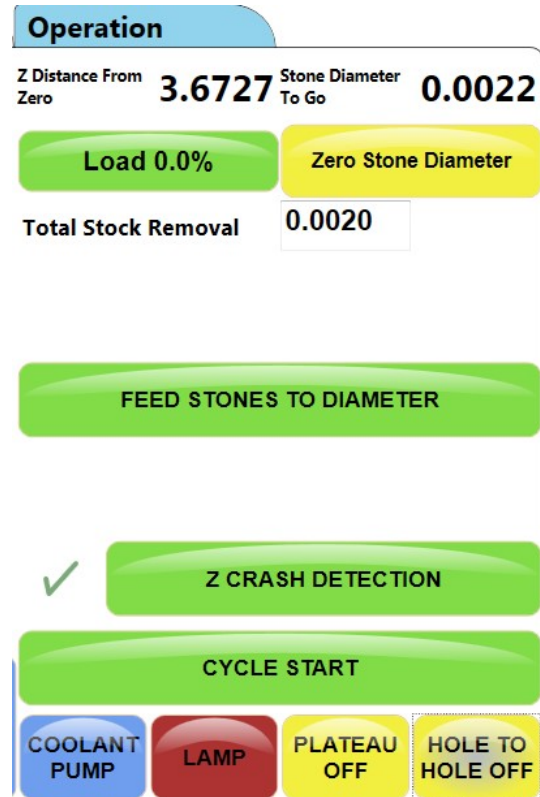

### Plateau Honing

Remove the stones and holders used in the honing process and install the brush and holder setup you selected for the job.



Touch the PLATEAU OFF button. It will turn red and read PLATEAU 4 STROKES. The number of strokes displayed will match the number you entered when doing the setup. You can change the number of strokes by maintaining contact with the



button until the number pad appears. Enter the number of strokes desired. Be certain that all the bores are active in the Bore Locations tabs.



With HOLE TO HOLE ON active touch the CYCLE START button



and the Plateau process will run automatically. The hone head will lower into the first cylinder, feed the brushes out until they reach the preset load setting. The machine will start the cycle, complete the number of strokes that were preset, then continue on to the remaining cylinders. When the cycle is complete the hone head will raise out of the cylinder and the machine will shut off.

### Saving block program

When the entire process is completed and you are ready to move on to the next job, touch the PROGRAM SELECT button.

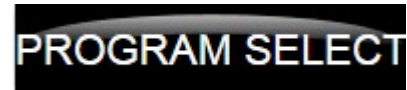

This pop up window will appear. Touch the Yes button to save you settings for later use.



# MAINTENANCE

## Contents

<b>Maintenance .....</b>	<b>6-1</b>
<b>Lubrication .....</b>	<b>6-1</b>
Grease Fittings .....	6-1
Automatic Lubricator .....	6-1
Grease Fitting Locations .....	6-2
Honing Coolant .....	6-4
Filter Unit Service .....	6-5
<b>Replacing X-Axis Drive Bearing .....</b>	<b>6-6</b>
<b>Reinstalling X-Axis motor on the H75X .....</b>	<b>6-10</b>
<b>Ballscrew Assemblies Reference .....</b>	<b>6-14</b>
Alignment Definitions for Angular Bearings and Belleville Washers .....	6-14
Bearing Alignment .....	6-14
Belleville Washer Alignment .....	6-14
<b>Z-Axis Bearing Installation Stacking Order .....</b>	<b>6-15</b>
Z-Axis Bearing Installation Section View .....	6-16
<b>Spindle Housing Bearing Installation Stacking Order .....</b>	<b>6-17</b>
Spindle Housing Bearing Installation Section View .....	6-18



## Maintenance



Follow all relevant safety procedures as described in Section 3 of this manual before performing any maintenance or repair procedure.

### Lubrication



Refer to the Material Safety Data Sheets in Section 10 for information on proper use and handling of lubricants mentioned in this maintenance section.

### Grease Fittings

There are grease fittings on the main carriage assembly, the optional clamp arm assemblies, and the optional Turn Over Fixture. See the following images for locations of grease fittings and intervals for adding grease.

***These grease fittings should be greased, using NLGI #2 White Lithium Grease.***

### Automatic Lubricator

The oil injection lubricator is located on the back of the main base. The oil injector lubricates the ballscrews. The automatic injection lubricator is controlled by the machine program. The controller will activate the injection lubricator at a predetermined time interval

***When needed***, add lubrication oil to the reservoir. ***Use ISO VG 68 Way Oil.***

**Grease Fitting Locations**

Each image shows the frequency of lubrication.

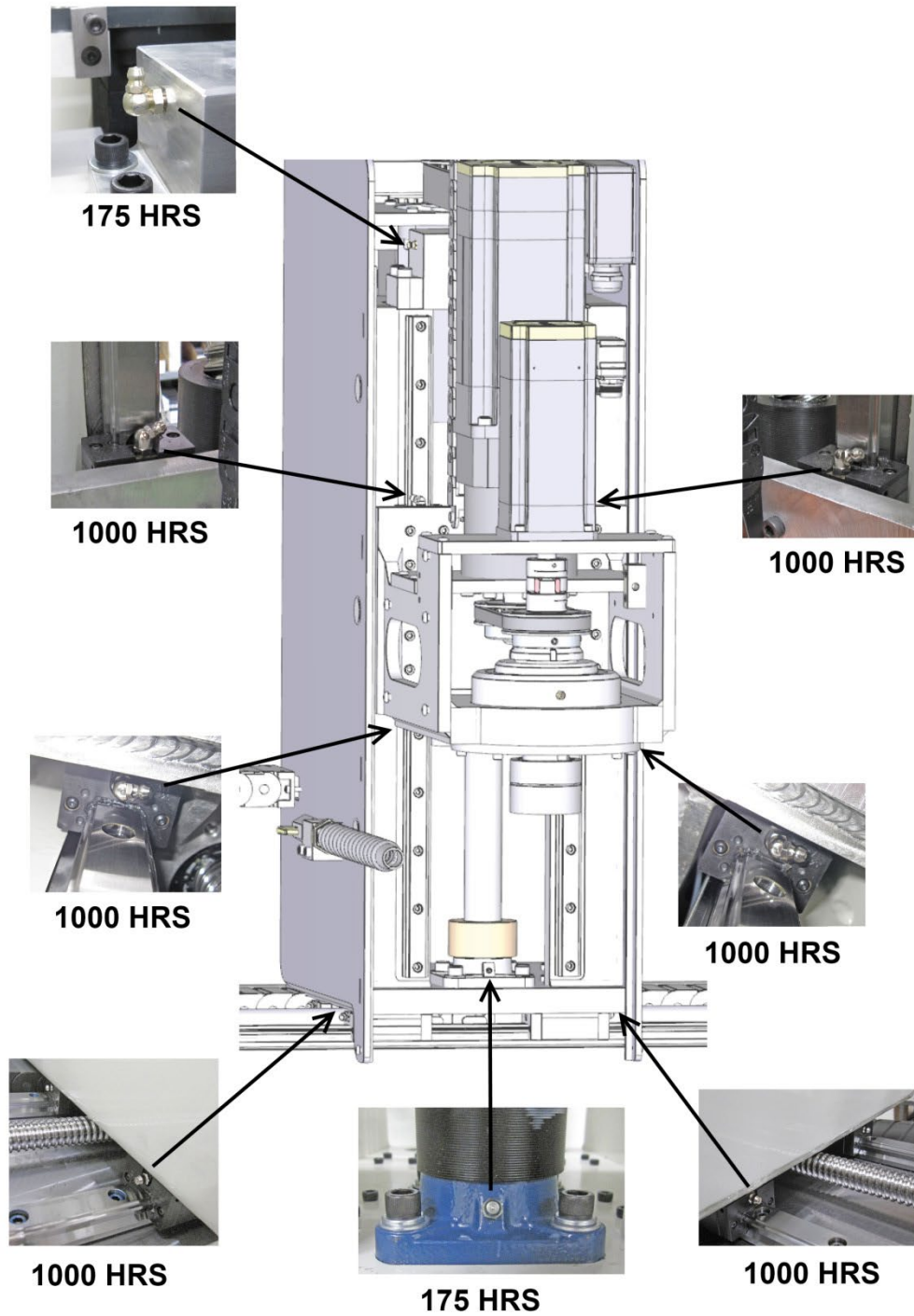

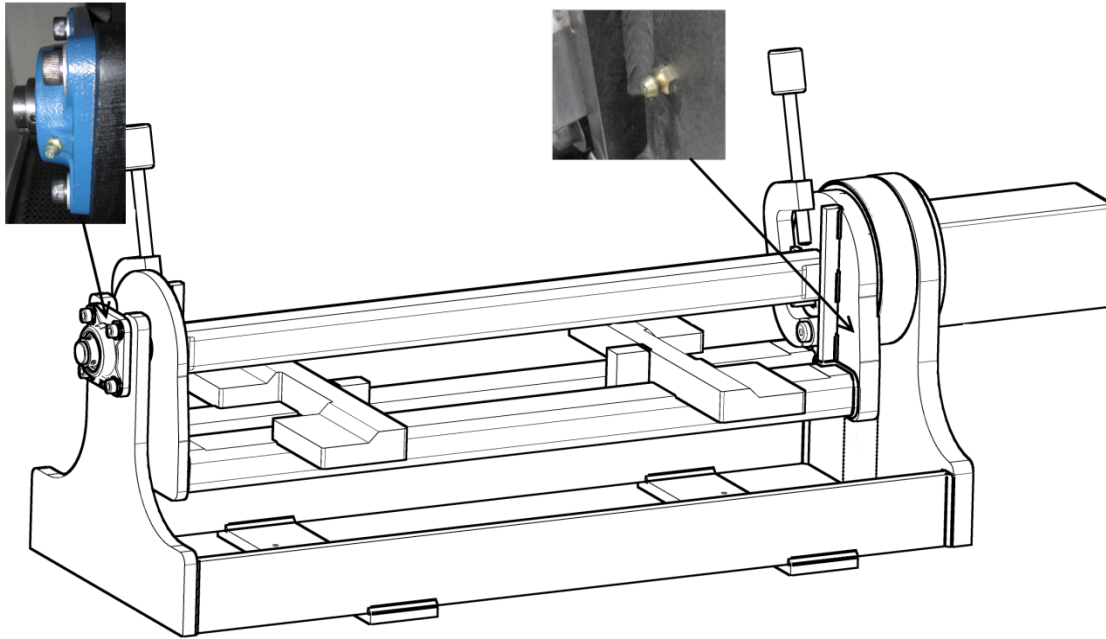

***Grease should be added every 175 hours of service time.***

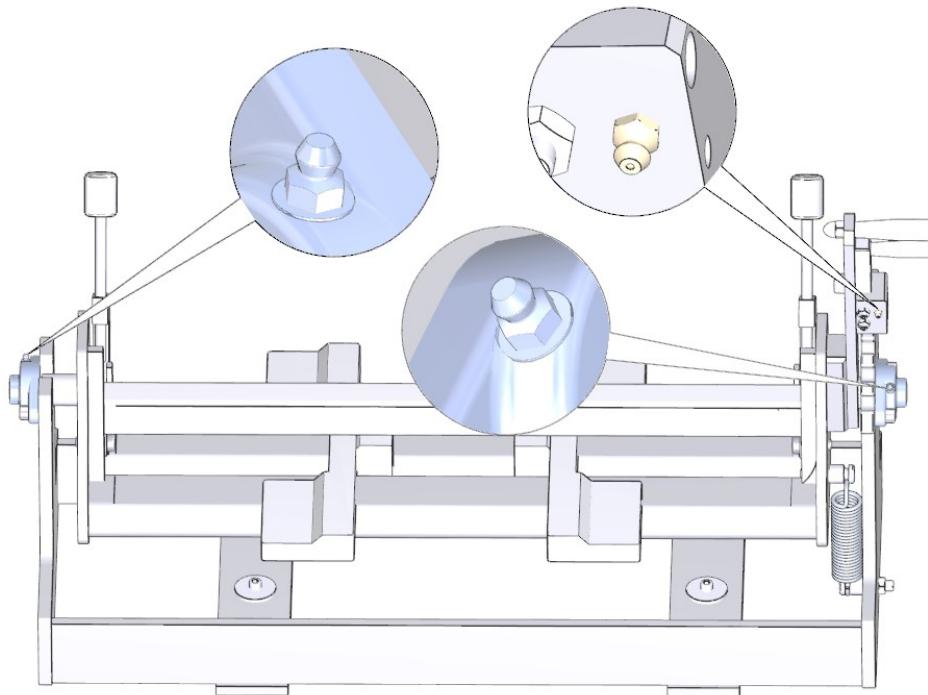

**Honing Coolant**

The coolant pump is located in the back of the splash tank. The coolant drains under the block fixture into a sump under the machine.

**Every 8 hours:**

Change the filter paper. Change the honing coolant when it gets dirty. When changing coolant, completely clean tank and filter screen. Refill with Rottler 514-4-71C coolant mixed with water to a reading of 3 – 5 on the Refractometer scale. If a Refractometer is not available then a static ratio of 5% - 8% is acceptable.

Ratio of coolant to water will be approximately 1:20 or 1 gallon of coolant for each 20 gallons of water.



**STRONG MAGNETIC FIELD**  
USE CAUTION WHILE HANDLING AROUND  
OTHER MAGNETIC MATERIAL  
**MAY POTENTIALLY CAUSE SERIOUS INJURY**



Remove housing from  
base unit

Remove dirty magnetic  
element from housing



Place magnetic element on  
supplied stand

Using supplied scrapper, remove  
build up from magnetic element



Place cleaned magnetic element  
back into housing and reattach  
to base unit

Replace porous element every 500 hours of service.

## Replacing X-Axis Drive Bearing



Follow all relevant safety procedures as described in Section 3 of this manual before performing any maintenance or repair procedure.

Move carriage to the center of the tank.

Shut off power.

Remove cables from X-Axis drive motor.

Remove 4 fasteners that hold motor to bearing housing.

Remove motor from bearing housing.

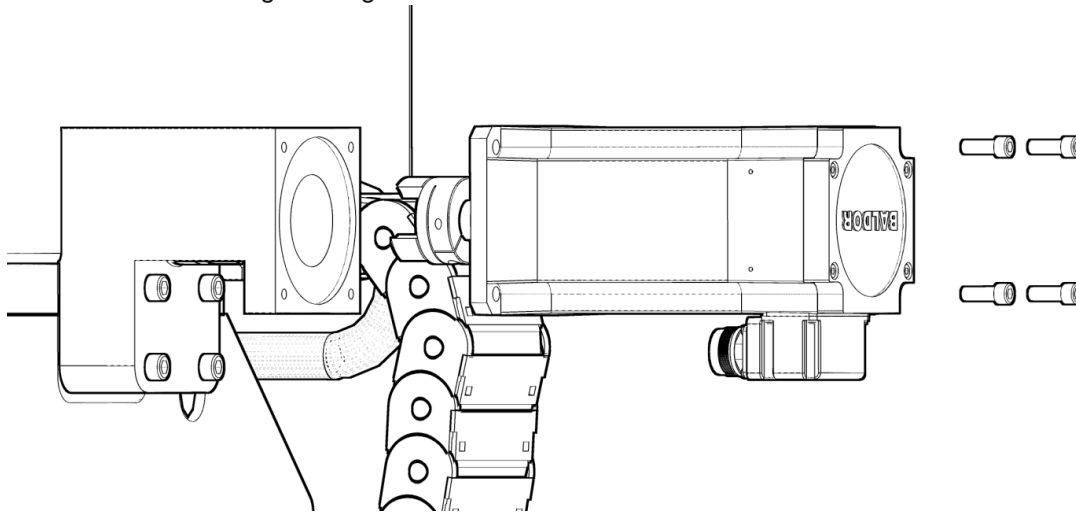

Remove spider coupling from ballscrew coupler if it remains in housing when motor is removed.

Remove ballscrew coupler from ballscrew.

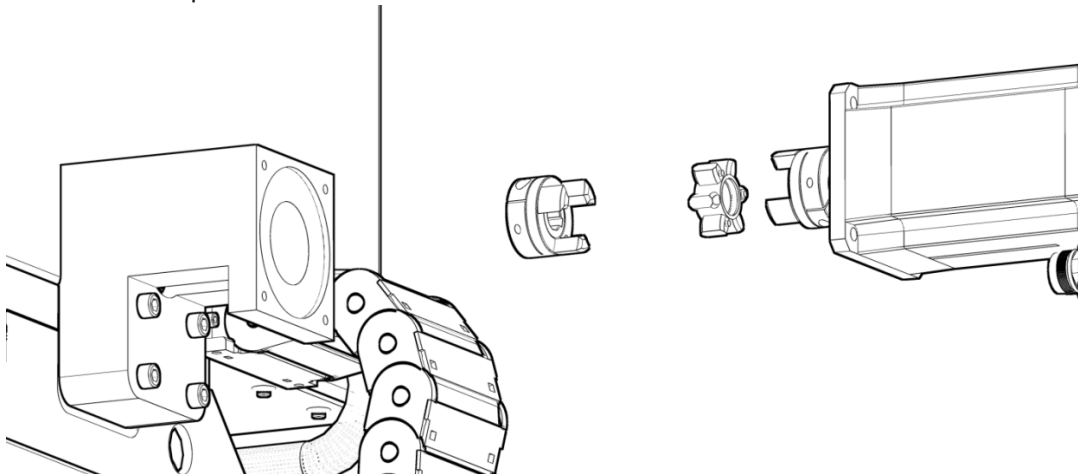

Remove fasteners holding bearing housing to tank.

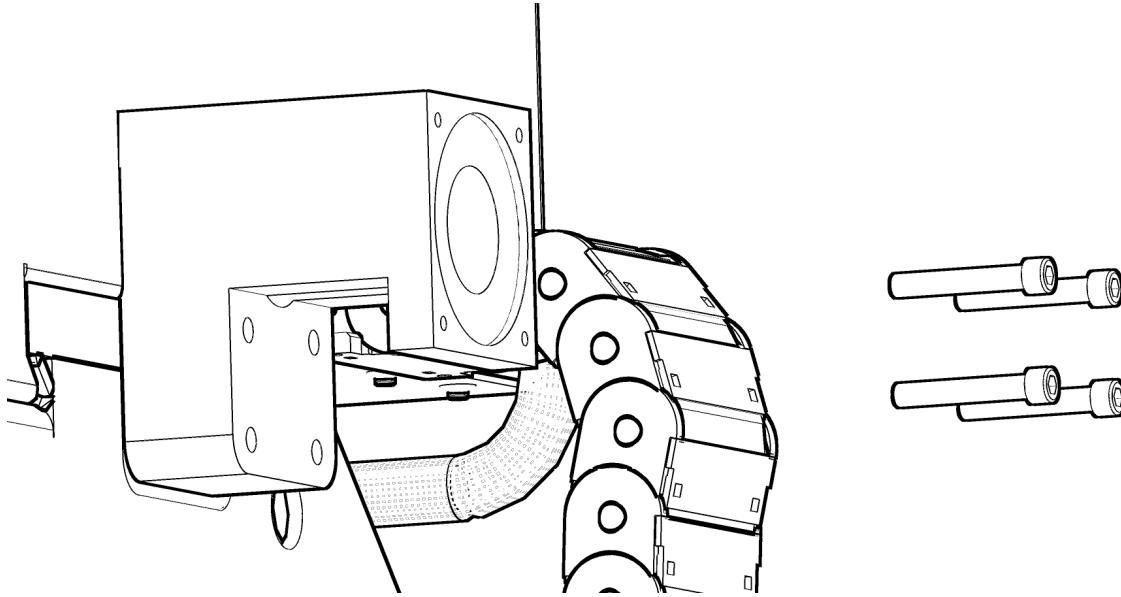

Move carriage to the right by hand so that the bearing housing clears the tank for access to the back.

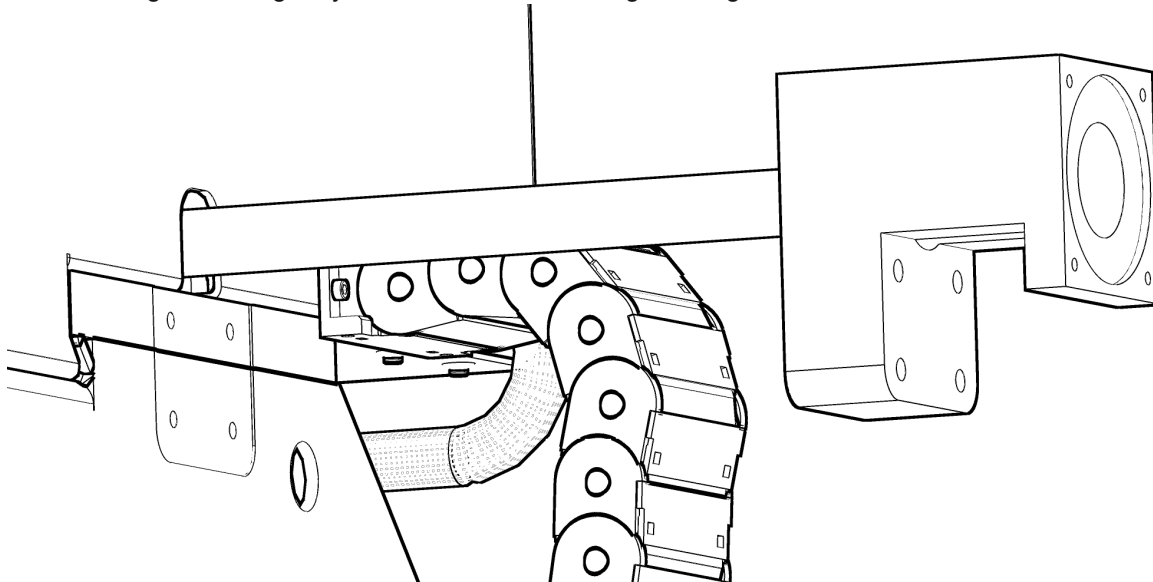

Remove fasteners holding bearing retainer to housing.

Remove bearing retainer from housing.

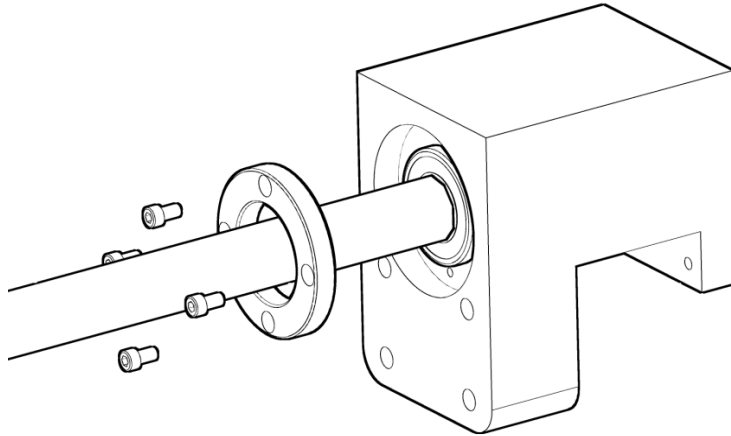

Remove bearing housing from ballscrew.

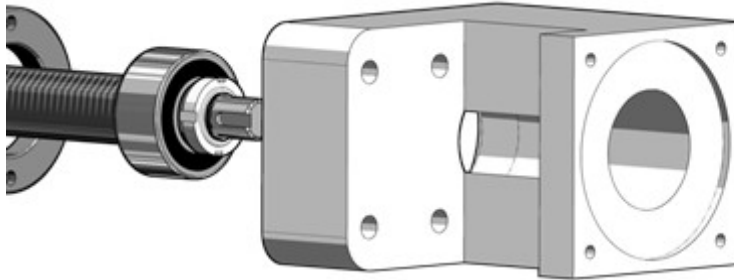

Use a spanner wrench inserted in the keyway to hold the ballscrew from turning.

Use a second spanner wrench to remove locknut from ballscrew.

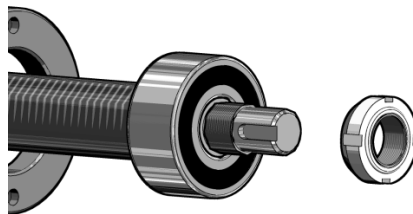



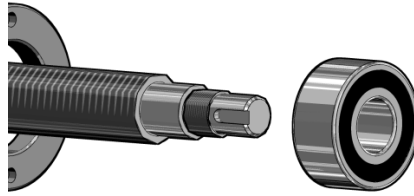

Reverse procedure to reassemble.

After reassembly the X-Axis travel stops will have to be established per set up procedure.

## Reinstalling X-Axis motor on the H75X



Follow all relevant safety procedures as described in Section 3 of this manual before performing any maintenance or repair procedure.

Turn on machine and go to Home screen.

Touch Setup Electronics menu tab, then touch Control on the drop down menu.

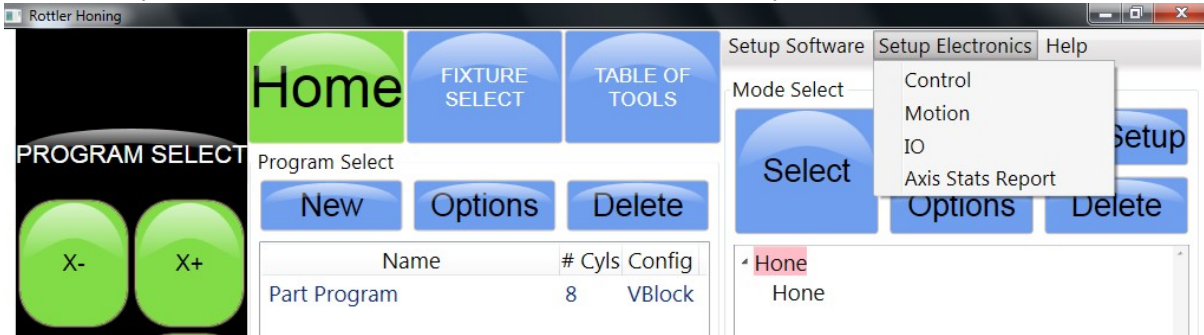

The Control Options window will appear.

Double touch the X line in the menu.

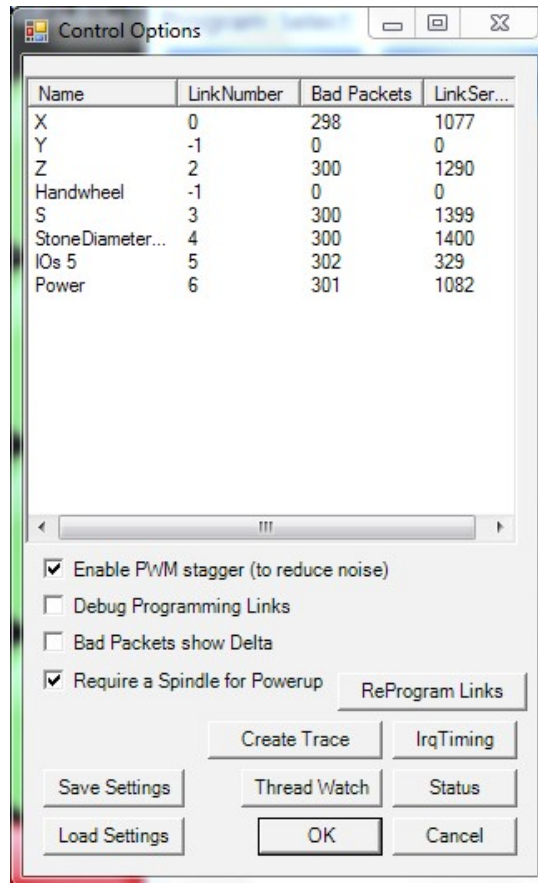

The X Setting screen will appear.

Open the Limits settings menu by touching the triangle.

Change both TOP and BOTTOM from TRUE to FALSE, by double touching TRUE and changing it to FALSE.

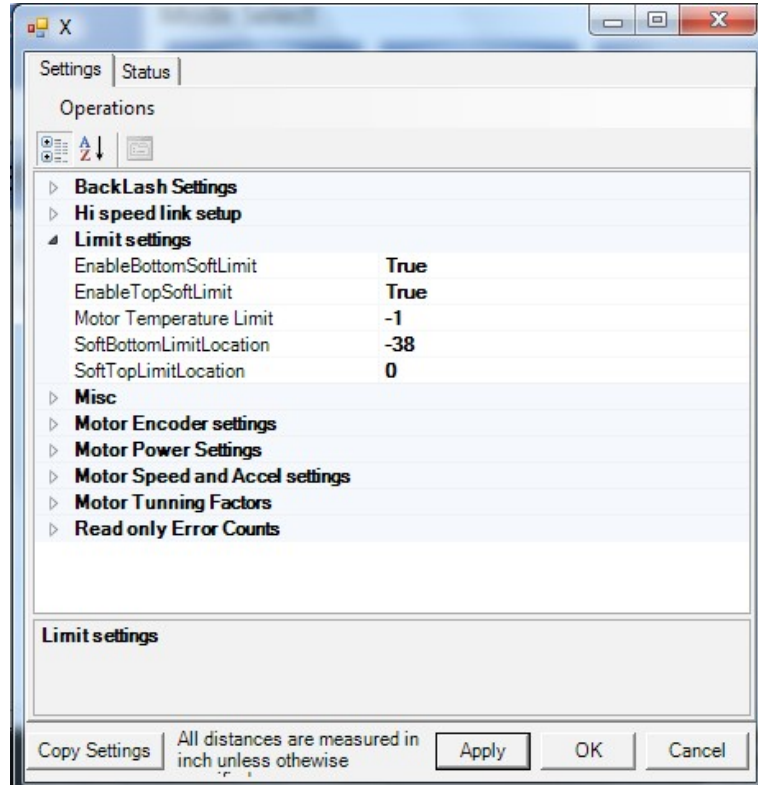

When both FALSE values are entered, touch the APPLY button.

**(CAUTION: DO NOT CHANGE LIMIT LOCATIONS UNLESS SPECIFIED BY A ROTTLER TECHNICIAN.)**

Use the Jog button to move the carriage to the zero point, about 0.5" away from the right side clamp mount bracket.

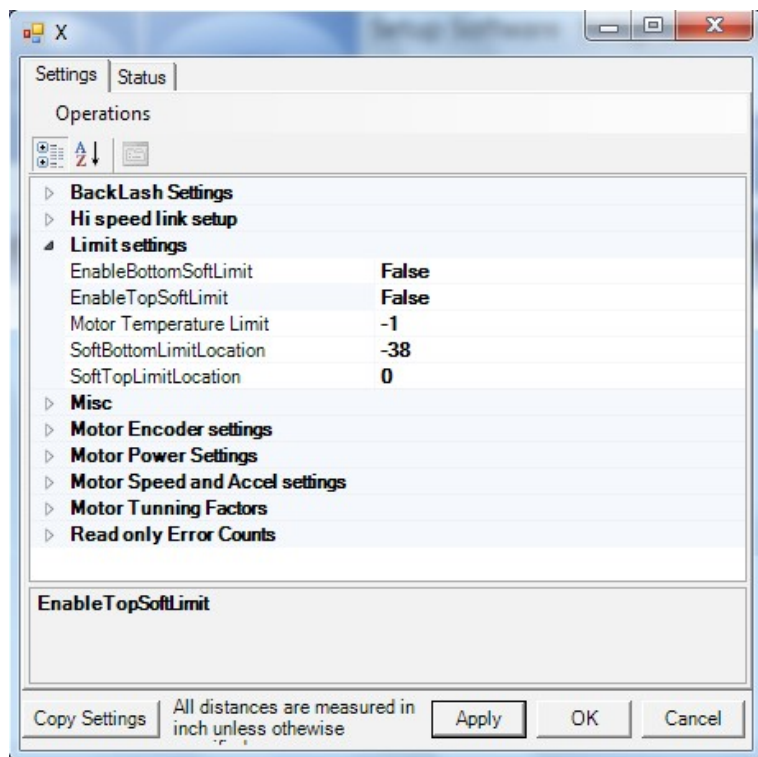

Section 6 Maintenance  
On the X Settings  
window touch the  
OPERATIONS menu  
tab. On the drop down  
menu touch the Set  
Home Preset line item.

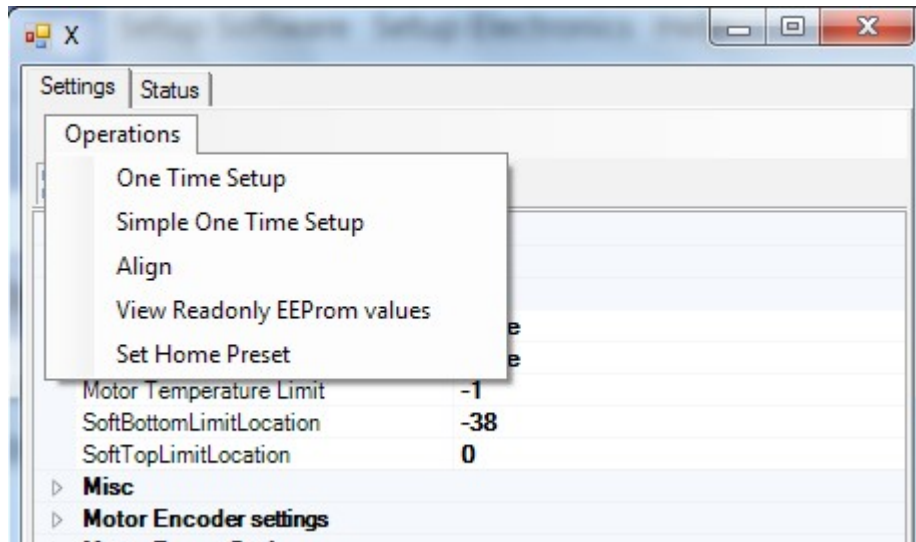

The InputBox window will appear. Confirm  
that the value box show zero. If not enter  
0.0, then touch the OK button.

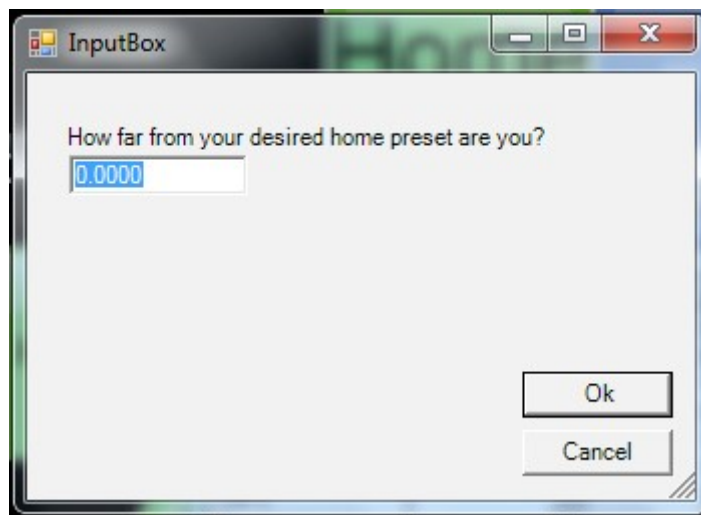

Section 6 Maintenance  
 Return to the X Settings  
 screen and change the  
 BOTTOM and TOP Soft  
 Limit settings from False  
 to True.

Touch the Apply button  
 to save the new settings.  
 Close Set Up menus.

Use the jog buttons to  
 confirm that settings are  
 correct.

**Ballscrew  
 Assemblies  
 Reference**

**Alignment  
 Definitions for  
 Angular Bearings  
 and Belleville  
 Washers**

**Bearing Alignment**

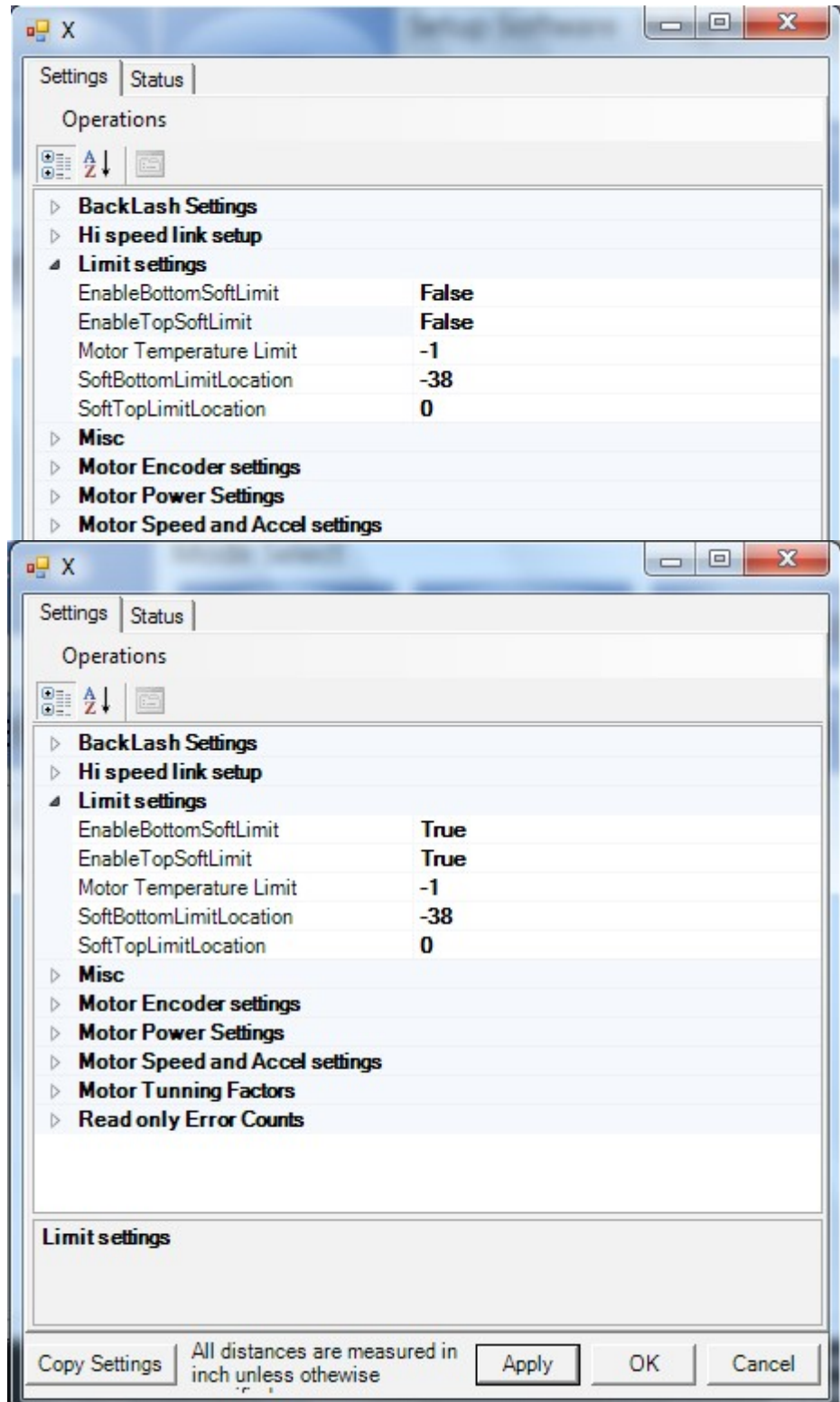



VIEW OPEN END UP



VIEW CLOSED END UP

**Belleville Washer Alignment**



VIEW CUP UP



VIEW CUP DOWN

**Z-Axis Bearing Installation Stacking Order**

Z-Axis bearings have an asymmetrical inner race design. See illustration below for proper stacking order of bearings.

2nd and 3rd bearings are install with open end up towards locknut.

1st bearing is installed closed end up towards locknut.

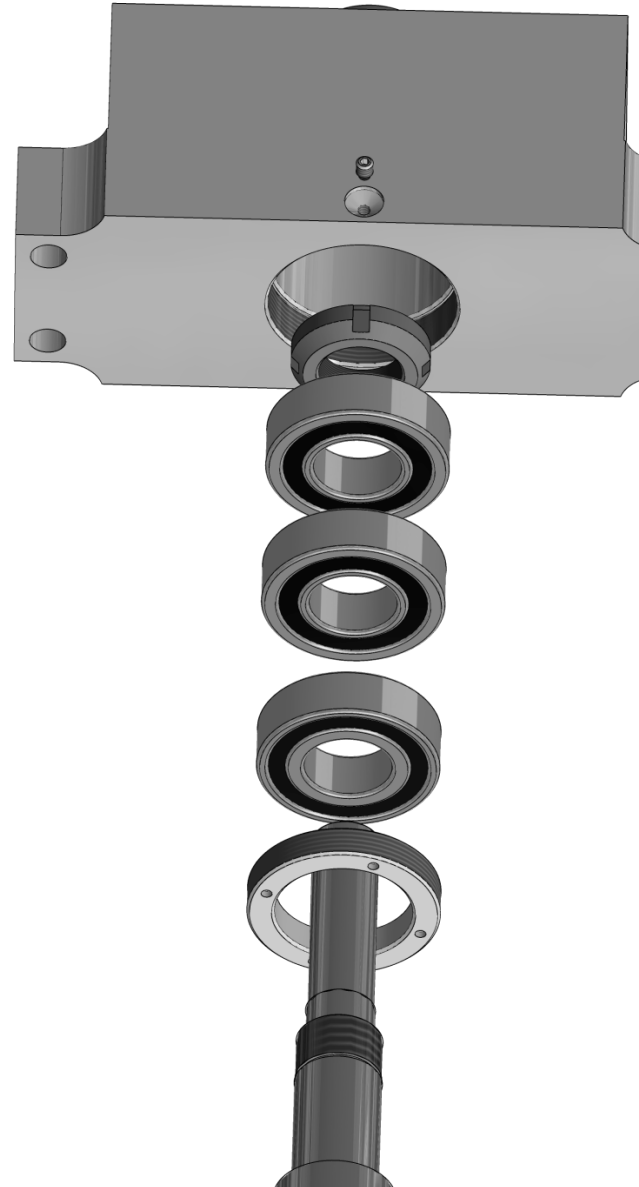

**Z-Axis Bearing Installation Section View**

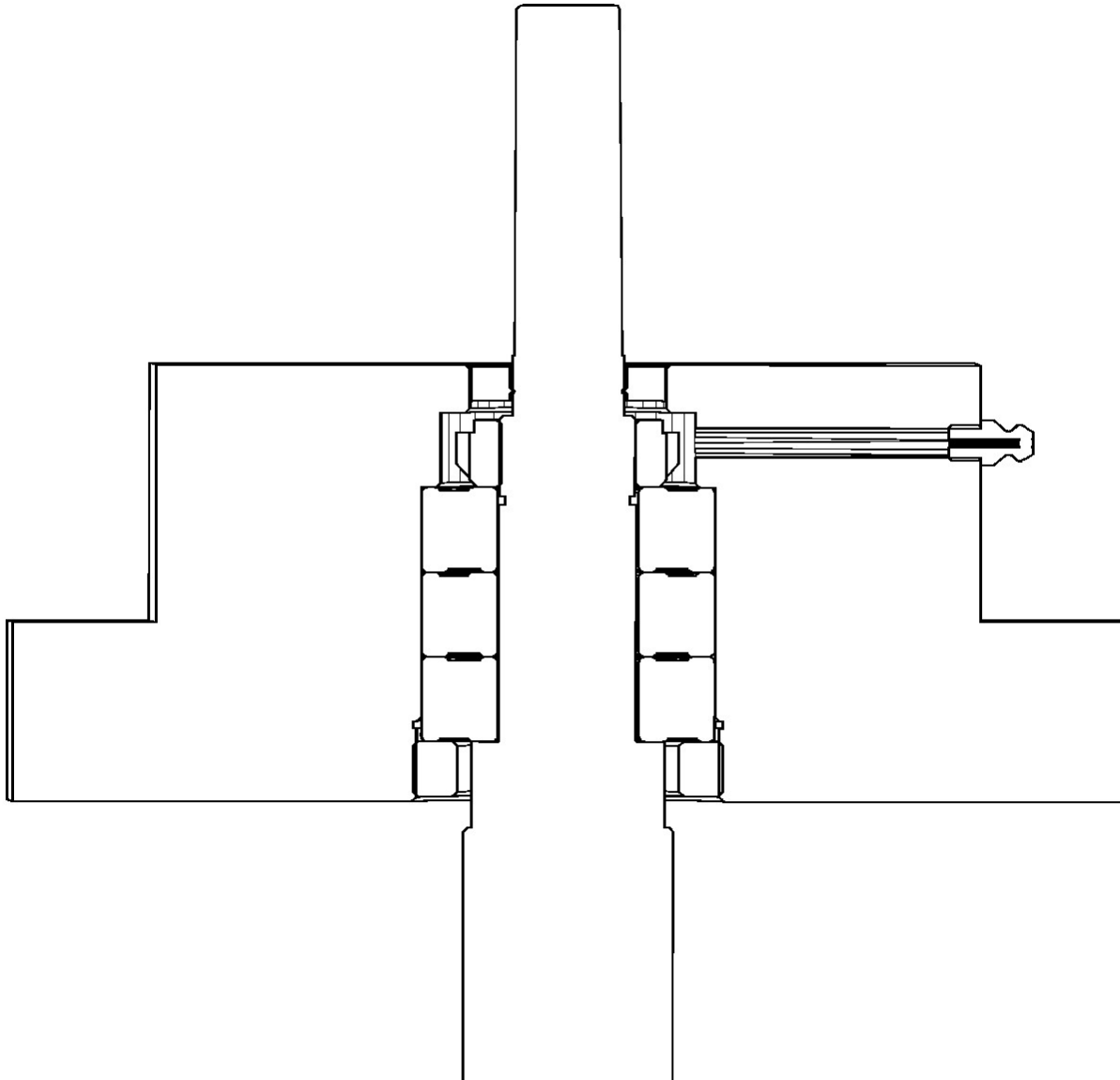



### Spindle Housing Bearing Installation Stacking Order

2nd bearing is installed with closed end down towards flange.

1st bearing is installed with open end down towards flange.

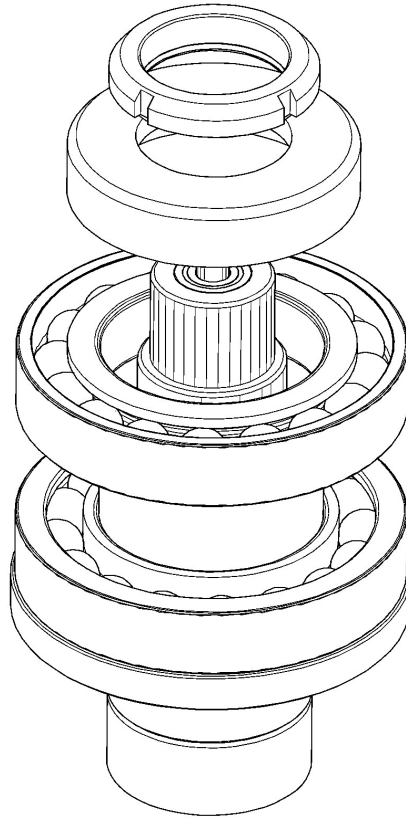

**Spindle Housing Bearing Installation Section View**

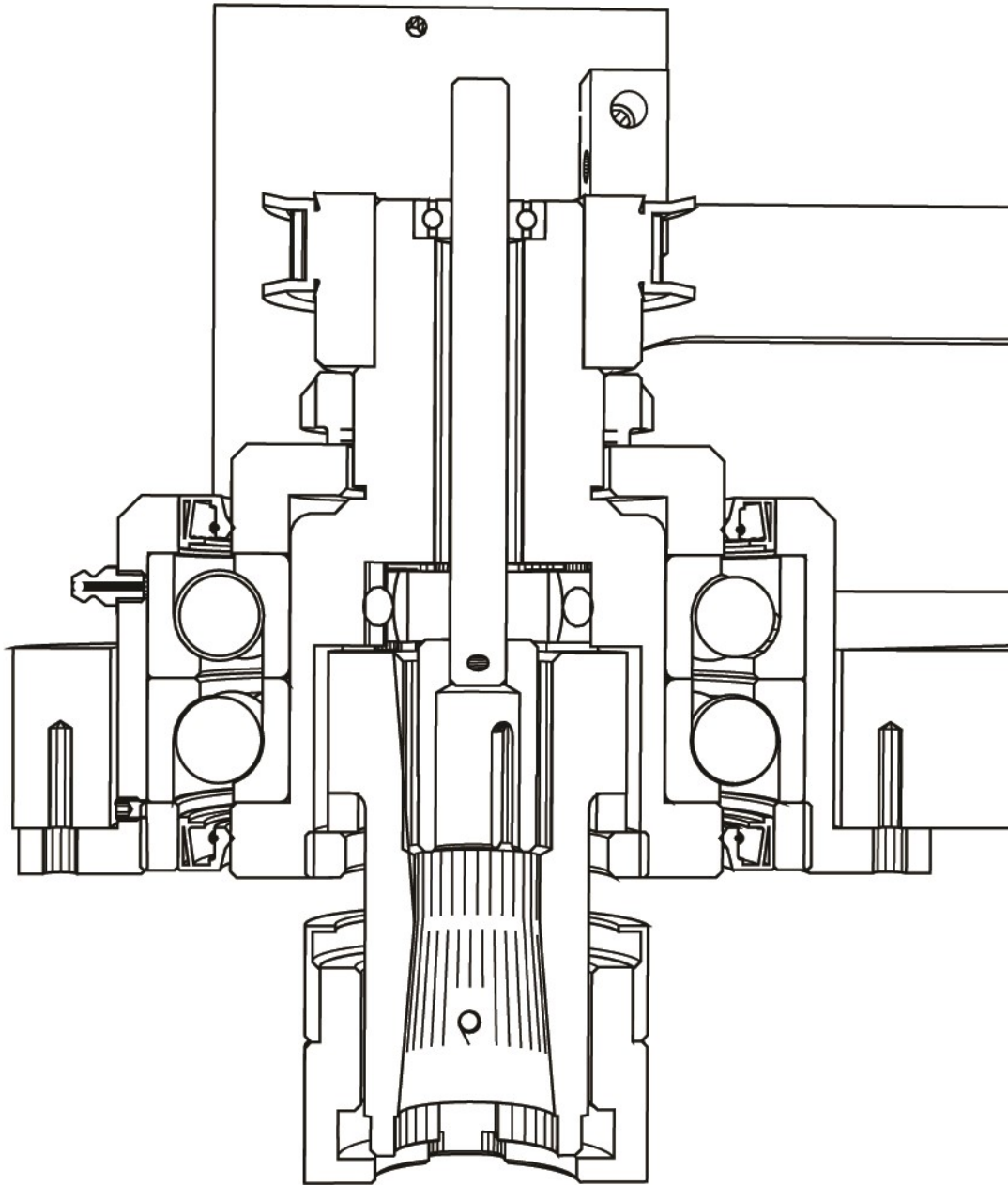

# **TROUBLESHOOTING**

**Please visit the service tab of our web page at Send a Service Request [www.rottlermfg.com](http://www.rottlermfg.com) or contact the Rottler Factory Service at [service@rottlermfg.com](mailto:service@rottlermfg.com) for assistance and your service request.**

**You may also call Rottler at 1-800-452-0534 or 1-253-872-7050**

**Please ensure you have the Machine Model and Serial Number available when contacting Rottler for Service**

# MACHINE PARTS

## Contents

<b>Machine Parts .....</b>	<b>8-1</b>
<b>Tank and Enclosure Assembly .....</b>	<b>8-1</b>
<b>Tank Assembly .....</b>	<b>8-2</b>
<b>Oiler and Components .....</b>	<b>8-3</b>
<b>X-Axis Idle End Components .....</b>	<b>8-4</b>
<b>X-Axis Motor .....</b>	<b>8-5</b>
<b>X-Axis Drive End Components .....</b>	<b>8-6</b>
<b>Linear Rails and X-Axis Ballscrew .....</b>	<b>8-7</b>
<b>Stone Tray and Clamp Arm Mount .....</b>	<b>8-8</b>
<b>Hone Head Rack .....</b>	<b>8-9</b>
<b>Screens and Covers .....</b>	<b>8-10</b>
<b>Filter Assembly .....</b>	<b>8-11</b>
<b>Tank Doors .....</b>	<b>8-12</b>
<b>Tank Enclosure 514-13-25 .....</b>	<b>8-13</b>
<b>X-Axis Assembly 514-13-67 .....</b>	<b>8-14</b>
<b>Carriage Assembly .....</b>	<b>8-16</b>
<b>Carriage Parts .....</b>	<b>8-17</b>
<b>Z-Axis Assembly .....</b>	<b>8-19</b>
<b>Z-Axis Assembly Components .....</b>	<b>8-20</b>
<b>Z-Axis Motor Components .....</b>	<b>8-23</b>
<b>Motor and Hub Housing Assembly .....</b>	<b>8-24</b>
<b>Motor and Hub Housing Assembly Components .....</b>	<b>8-25</b>
<b>Spindle Drive Assembly .....</b>	<b>8-27</b>
<b>Spindle Drive Assembly Components .....</b>	<b>8-28</b>
<b>Spindle Drive Bearing Install .....</b>	<b>8-29</b>



<b>Drive Hub Components .....</b>	<b>8-30</b>
<b>Kwik Switch Components .....</b>	<b>8-31</b>
<b>Adjusting Shaft Assembly .....</b>	<b>8-33</b>
<b>Spindle Drive Mount and Work Lights .....</b>	<b>8-34</b>
<b>Spindle Drive Motor Components .....</b>	<b>8-35</b>
<b>Feed Motor Components .....</b>	<b>8-36</b>
<b>Right Side Enclosure .....</b>	<b>8-37</b>
<b>Electrical Enclosure Wire Tracks .....</b>	<b>8-38</b>
<b>Coolant Nozzle Components .....</b>	<b>8-39</b>
<b>Rear Wire Track .....</b>	<b>8-40</b>
<b>Rear Enclosure .....</b>	<b>8-41</b>
<b>Left Enclosure .....</b>	<b>8-42</b>
<b>Carriage Cover and Ballscrew Curtain .....</b>	<b>8-43</b>
<b>Control Enclosure Mount .....</b>	<b>8-44</b>
<b>Electrical Enclosure Components .....</b>	<b>8-45</b>
<b>Electrical Enclosure Parts Inside .....</b>	<b>8-47</b>
<b>Electrical Panel .....</b>	<b>8-48</b>
<b>Control Panel Housing Components .....</b>	<b>8-49</b>
<b>Wiring Diagram .....</b>	<b>8-51</b>

**Machine Parts**

**Tank and Enclosure Assembly**

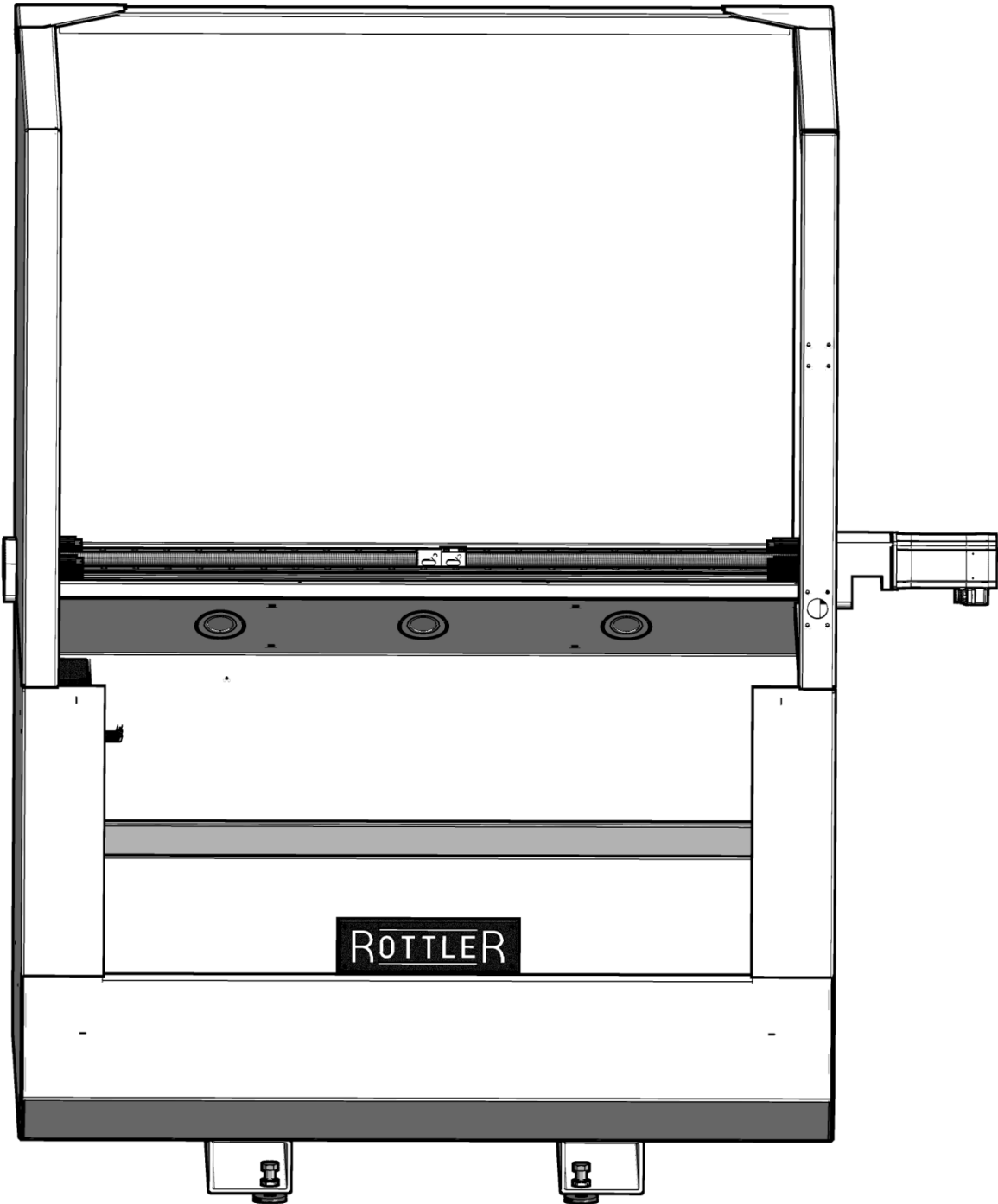

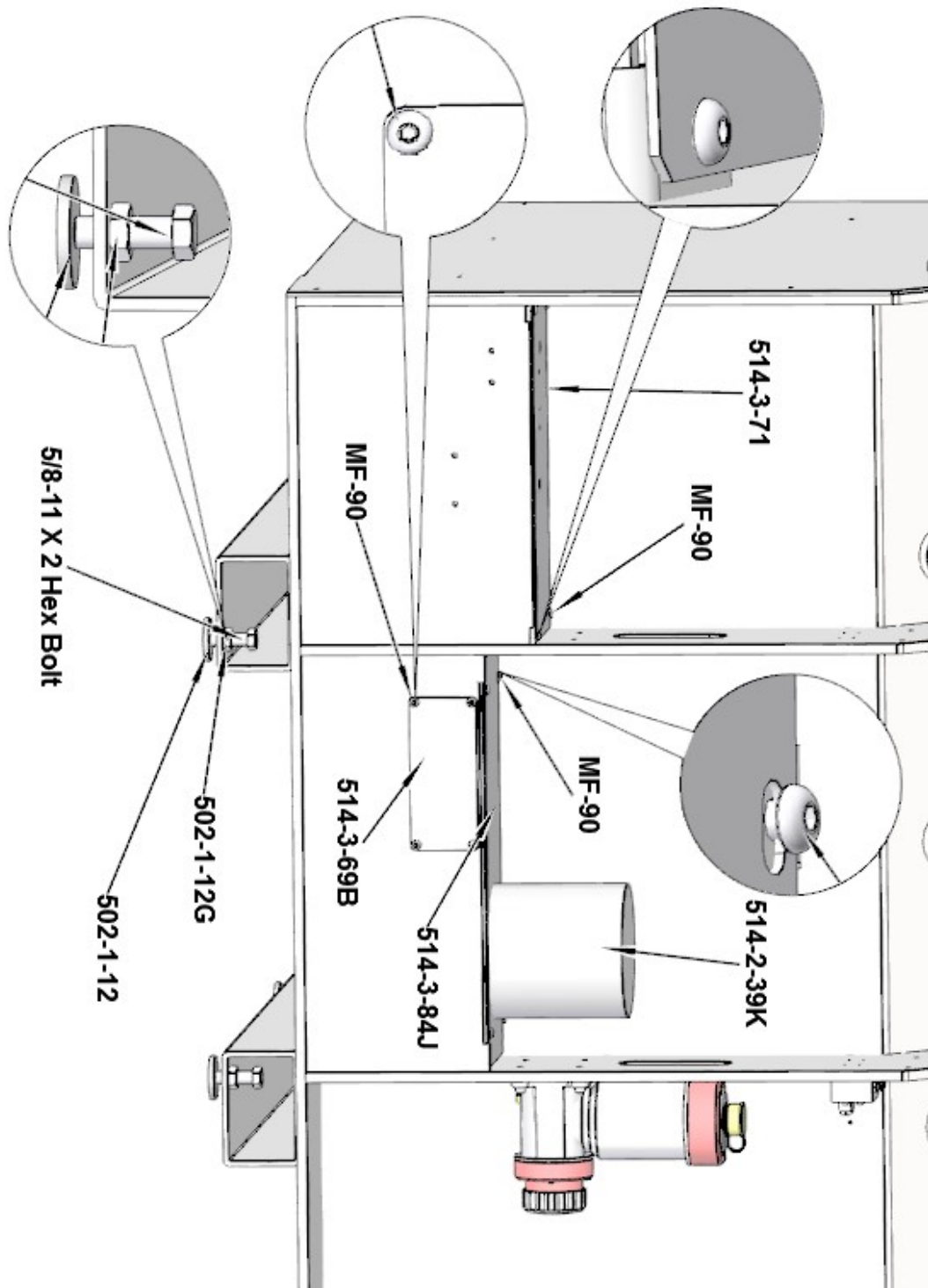



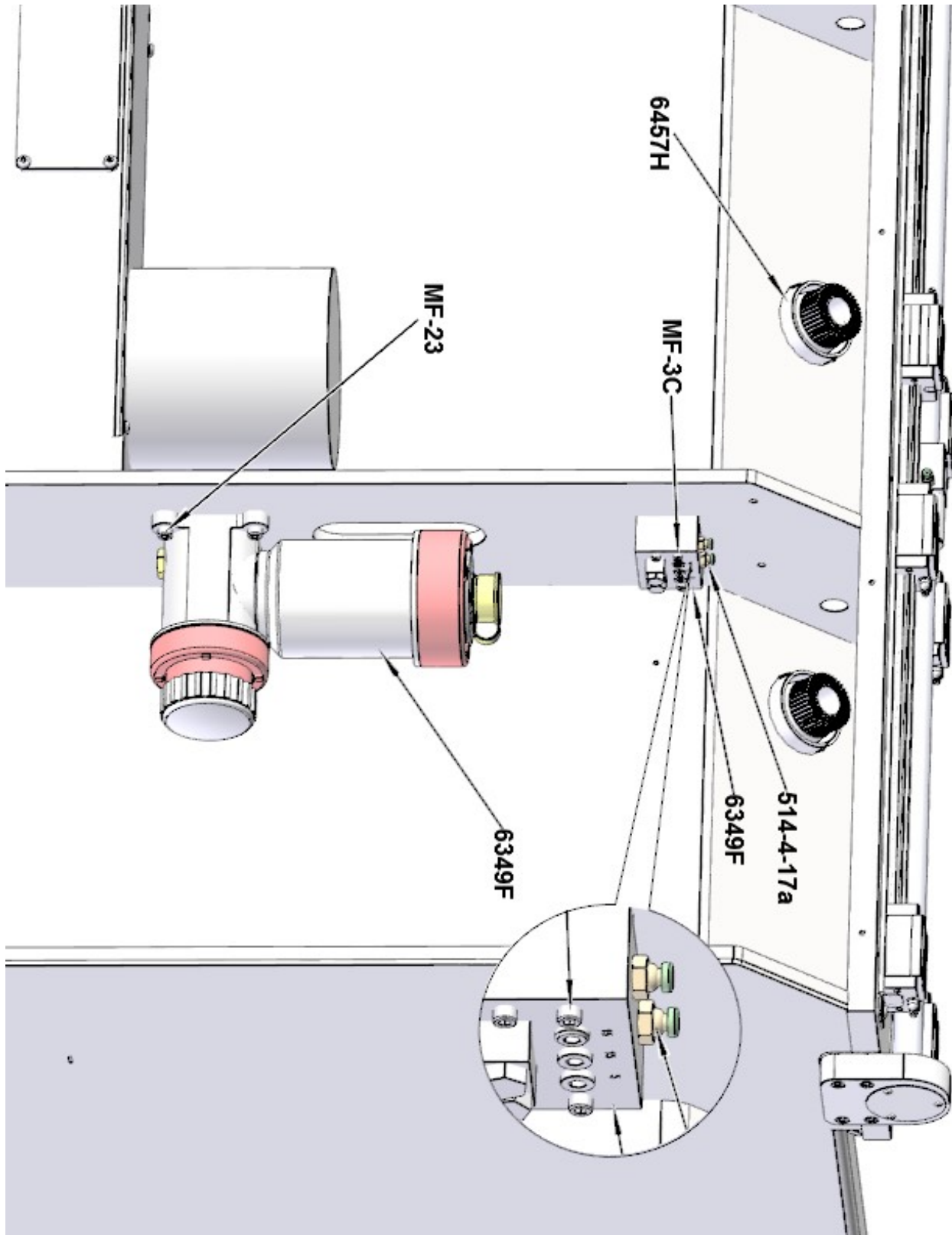

**X-Axis Idle End Components (H75X only)**

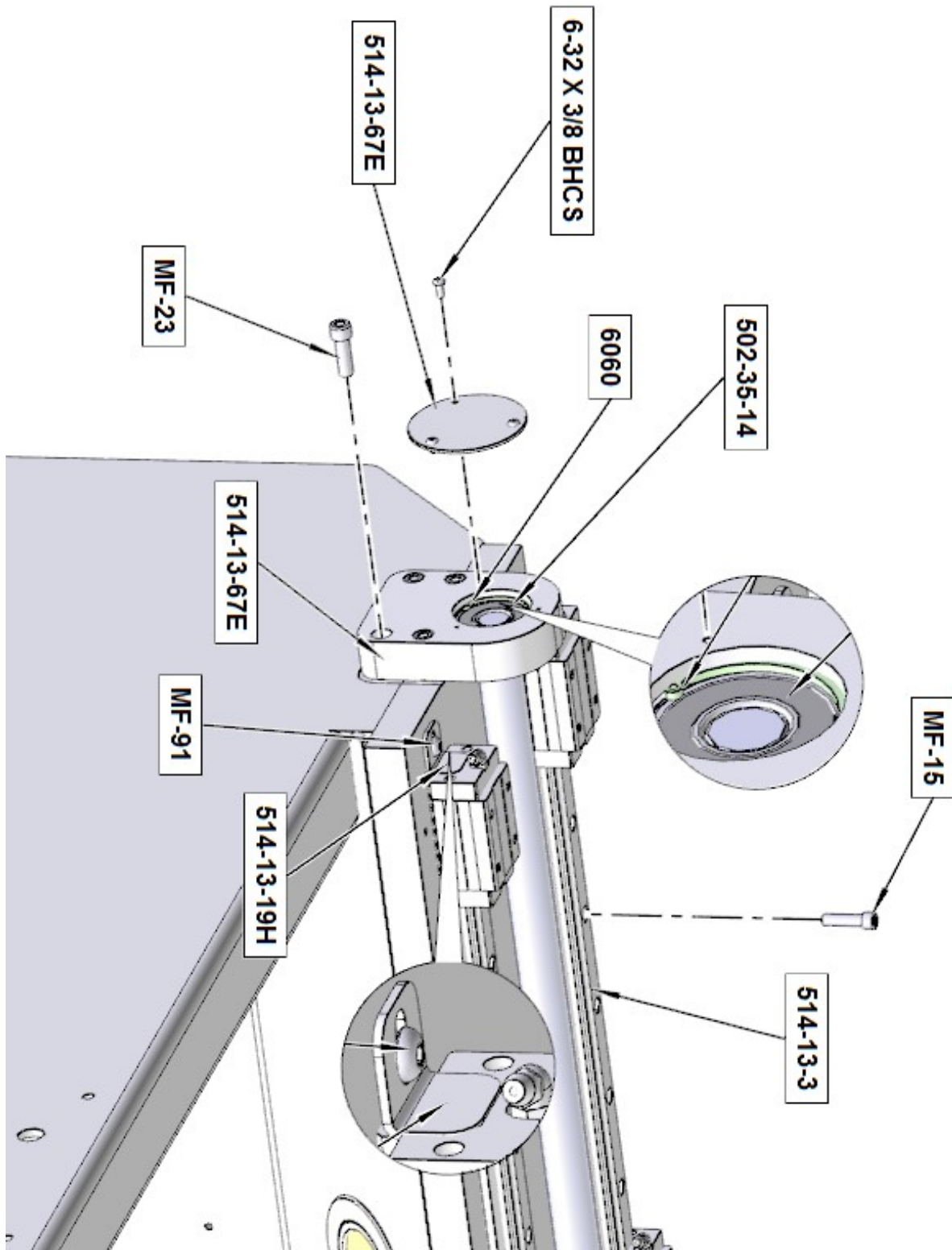

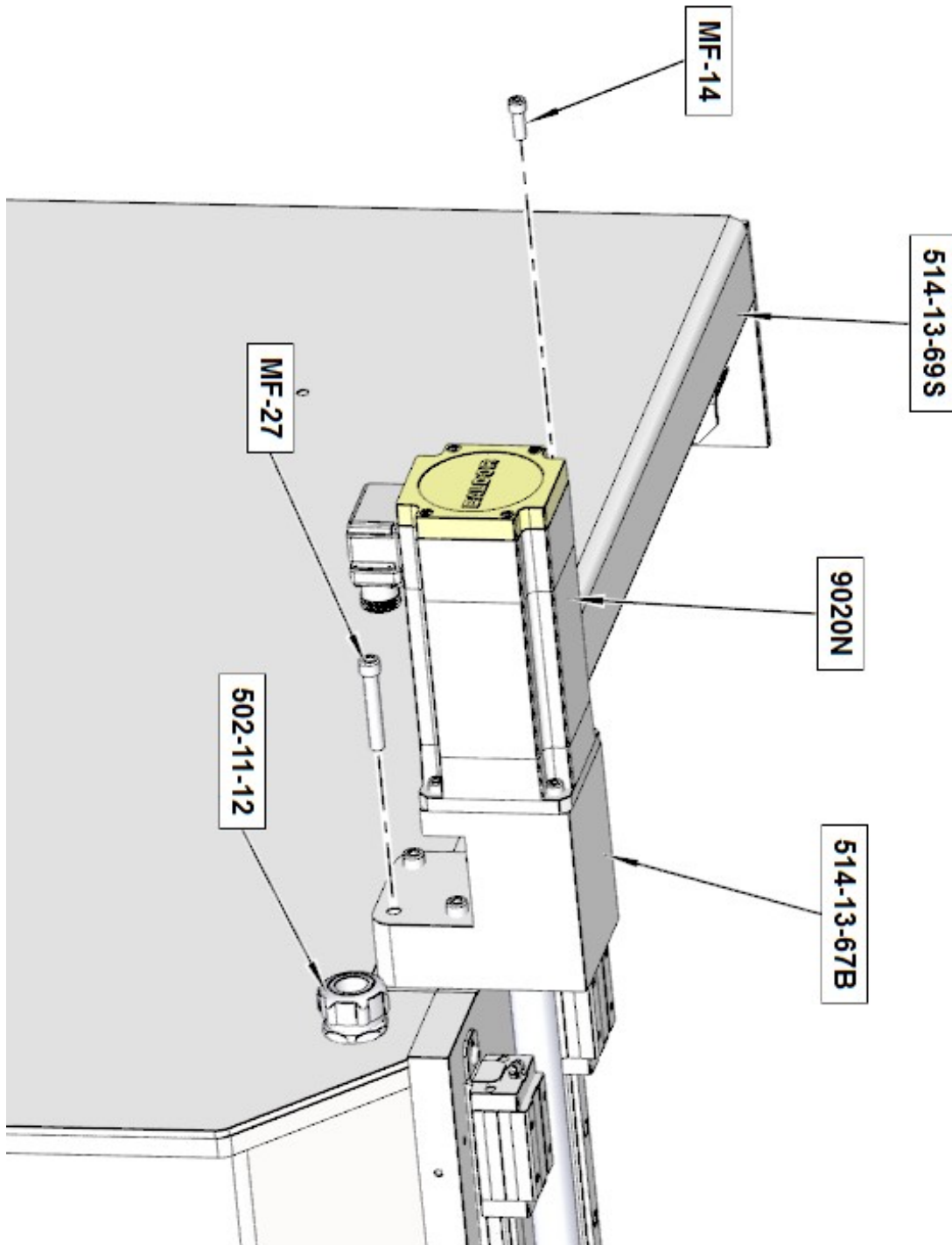

**X-Axis Drive End Components (H75X only)**

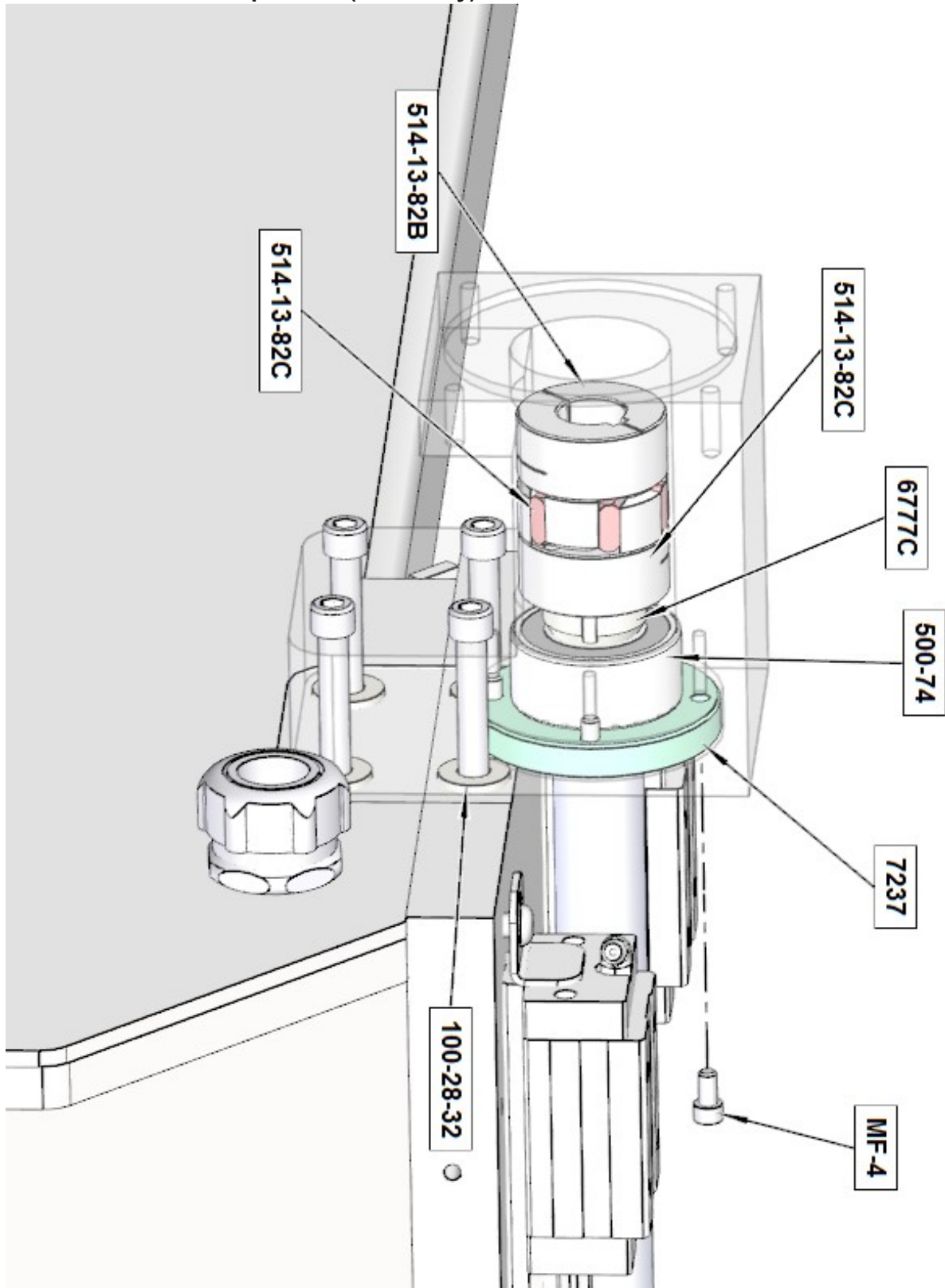

**Linear Rails and X-Axis Ballscrew (Ballscrew H75X only)**

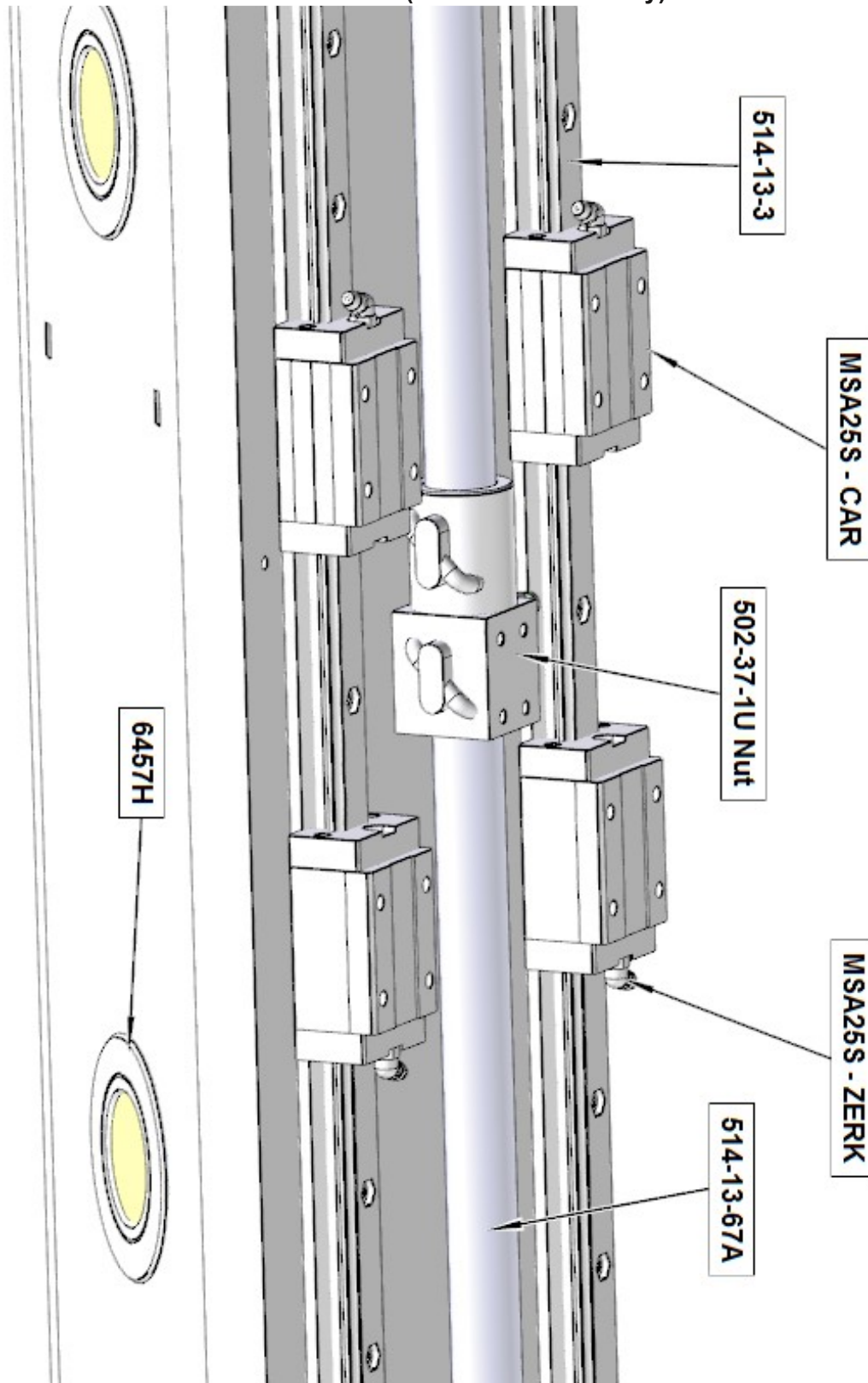

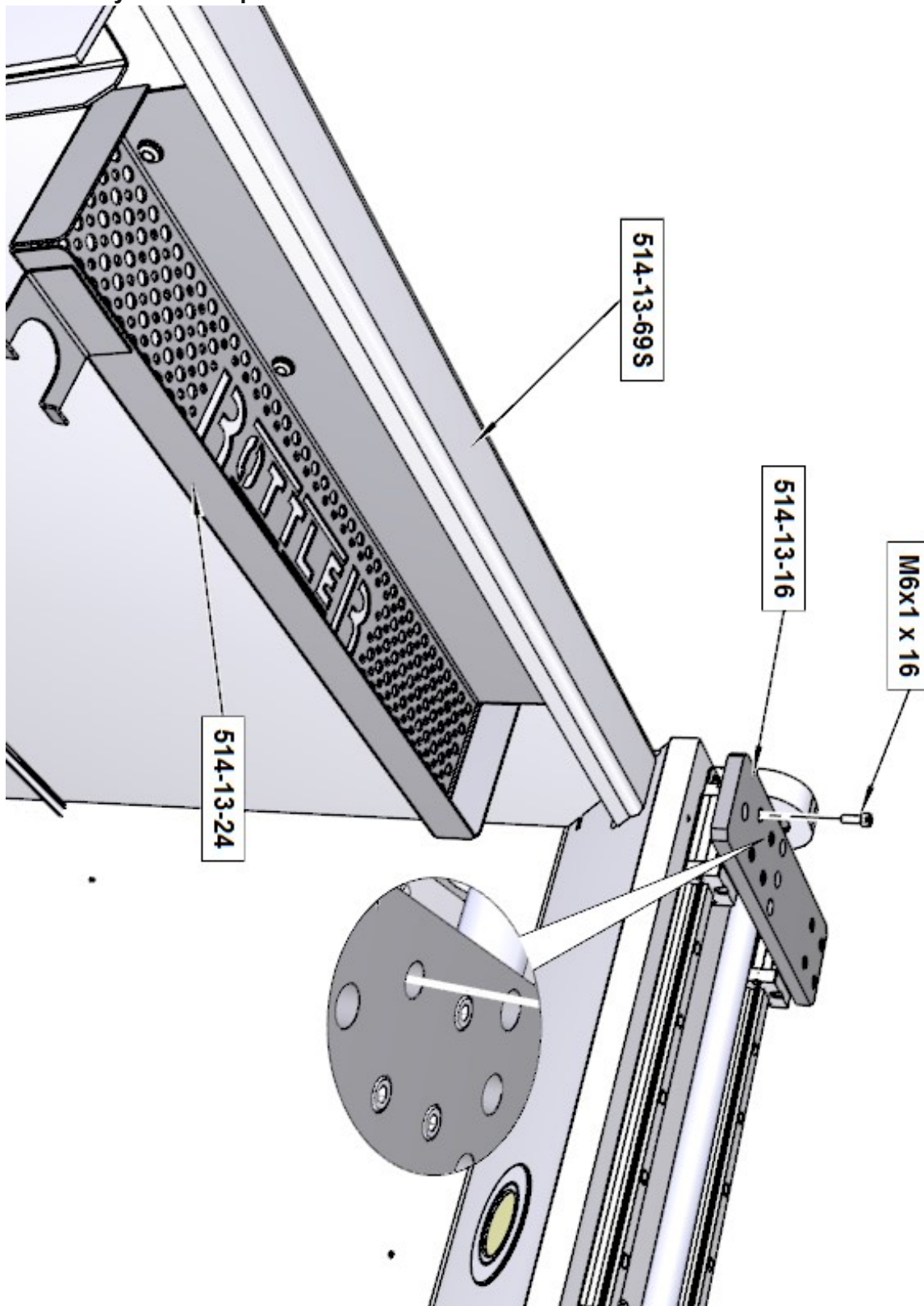

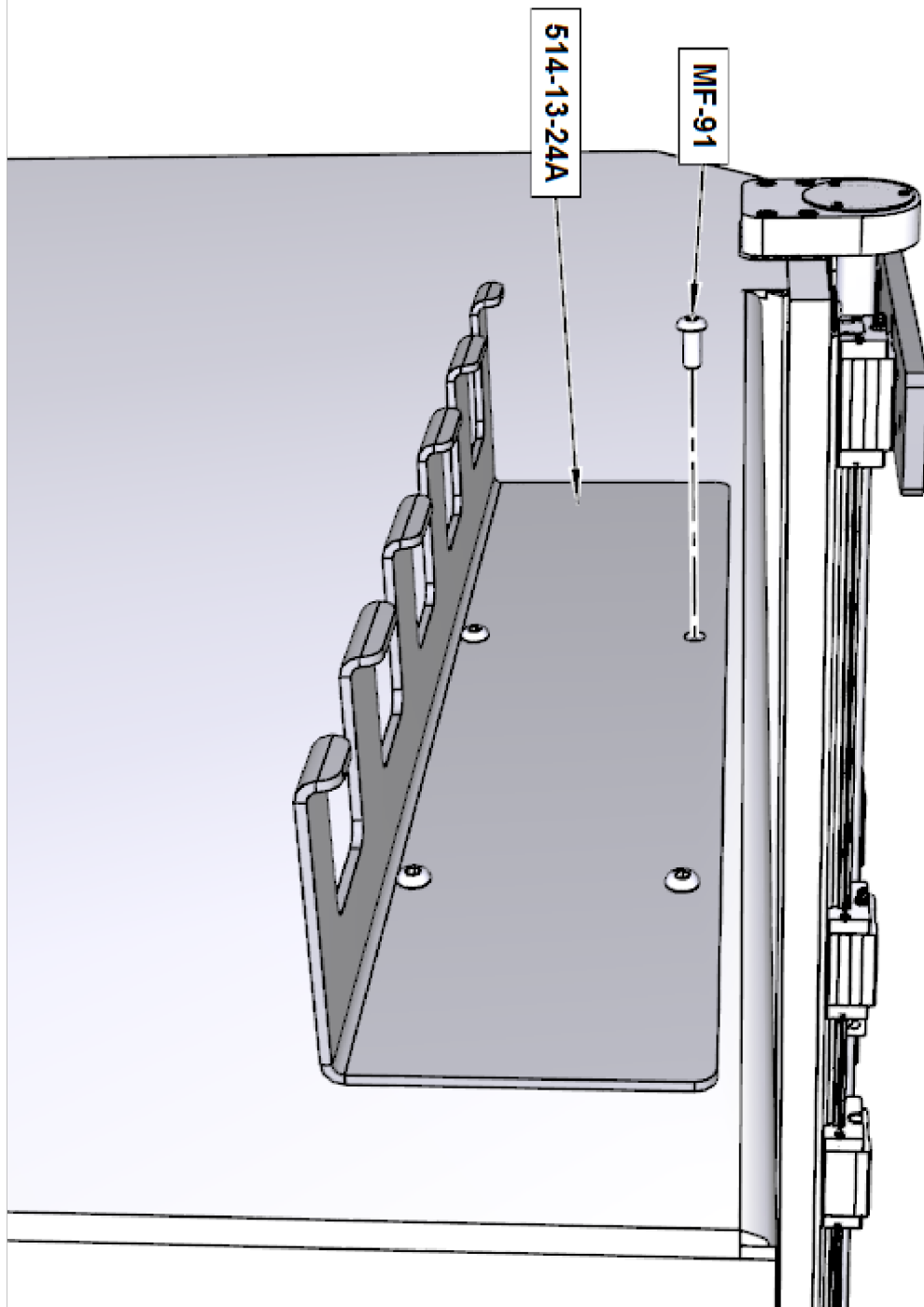

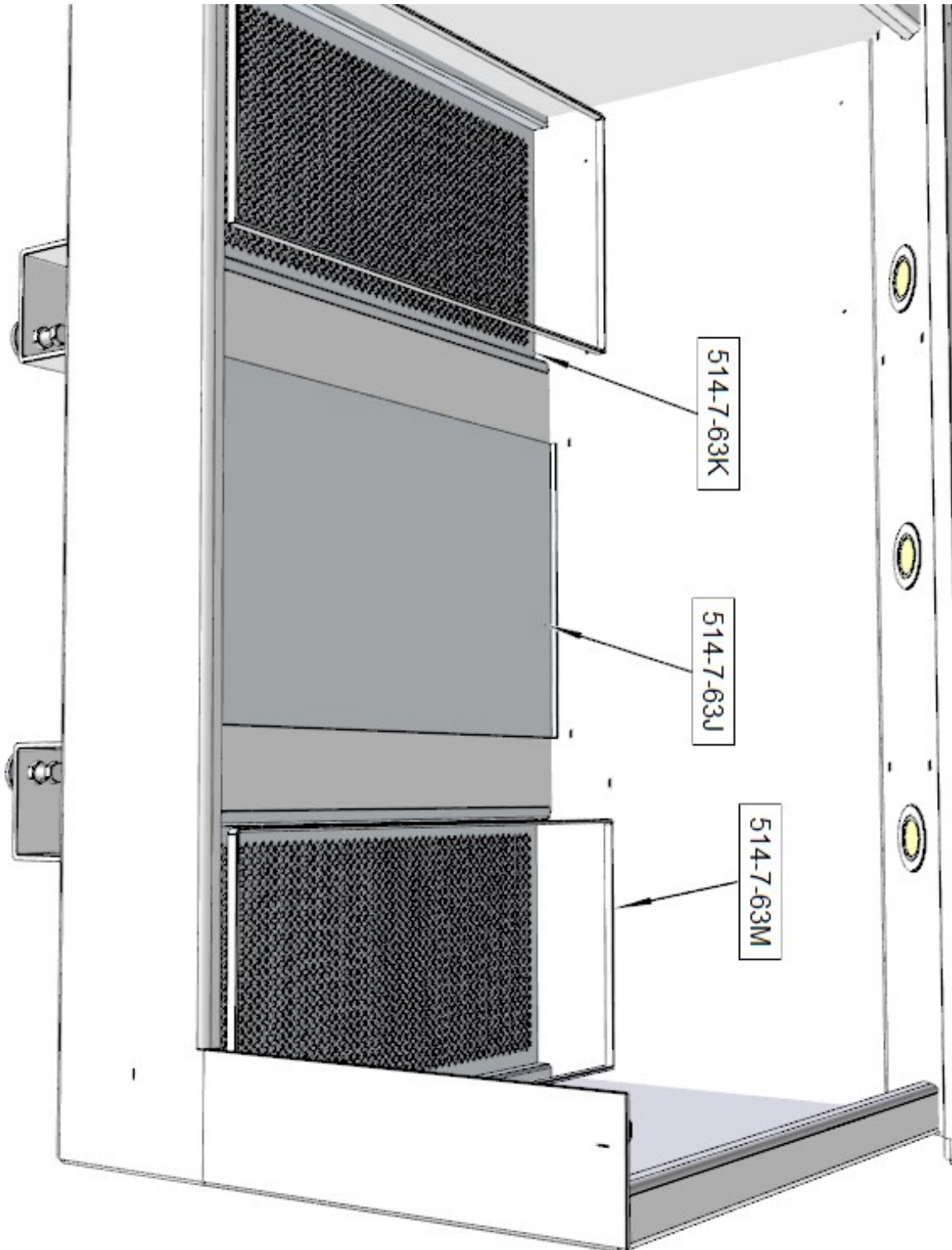



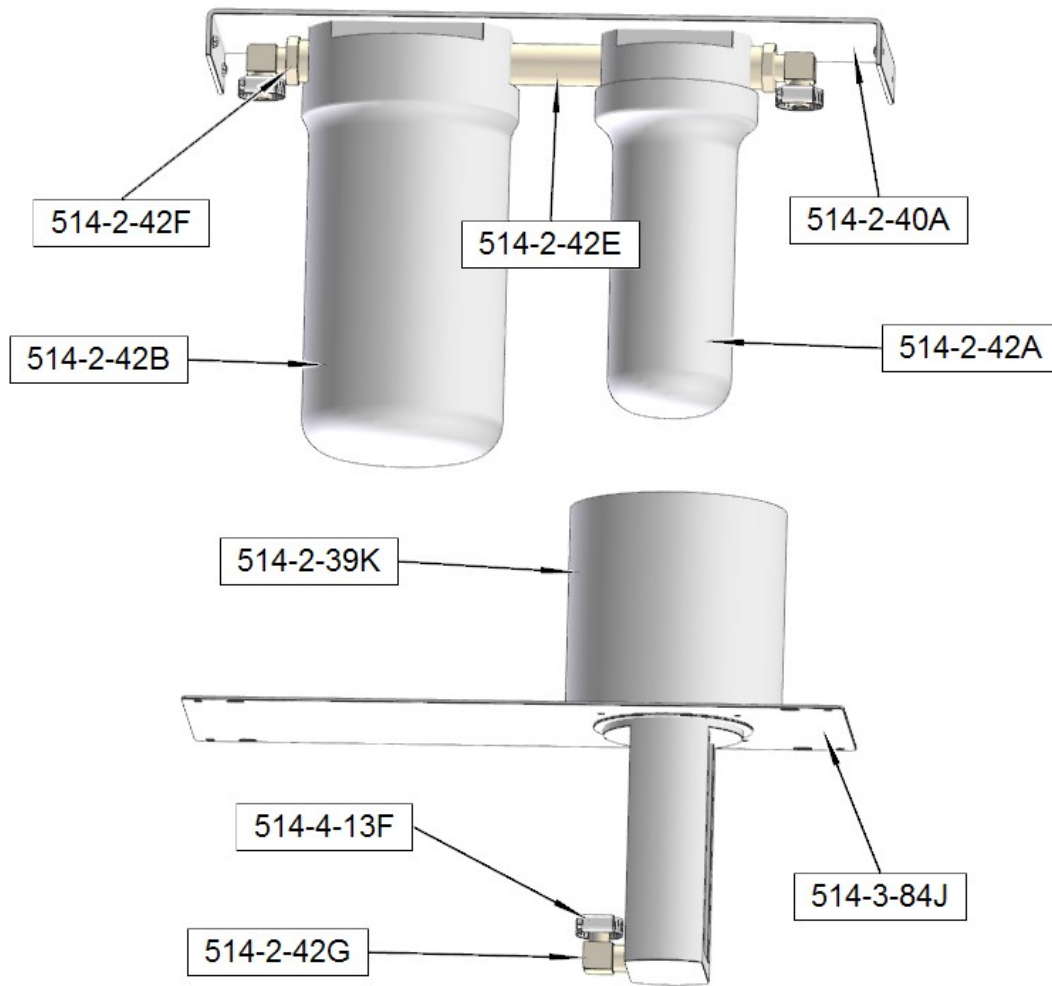

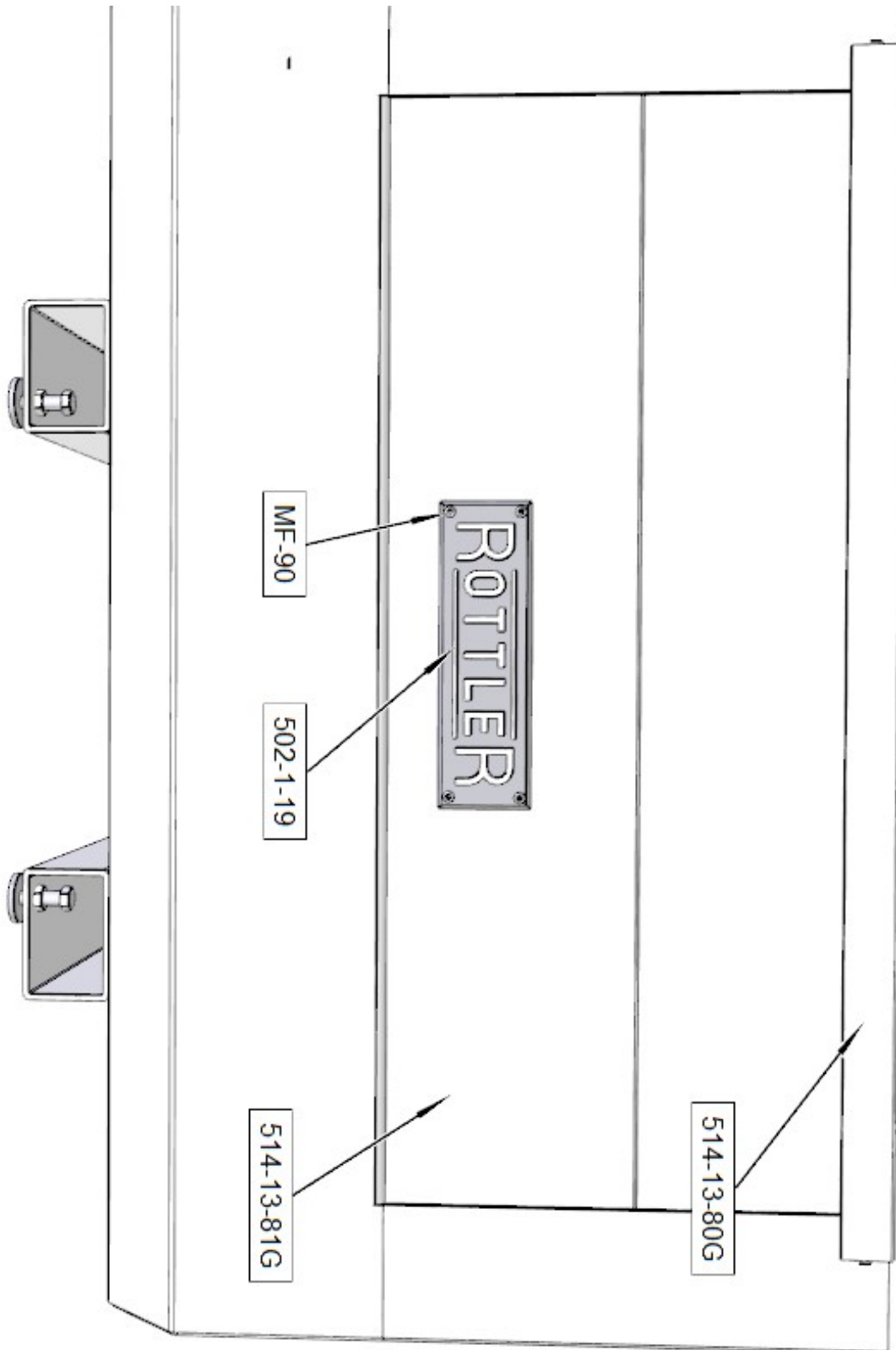

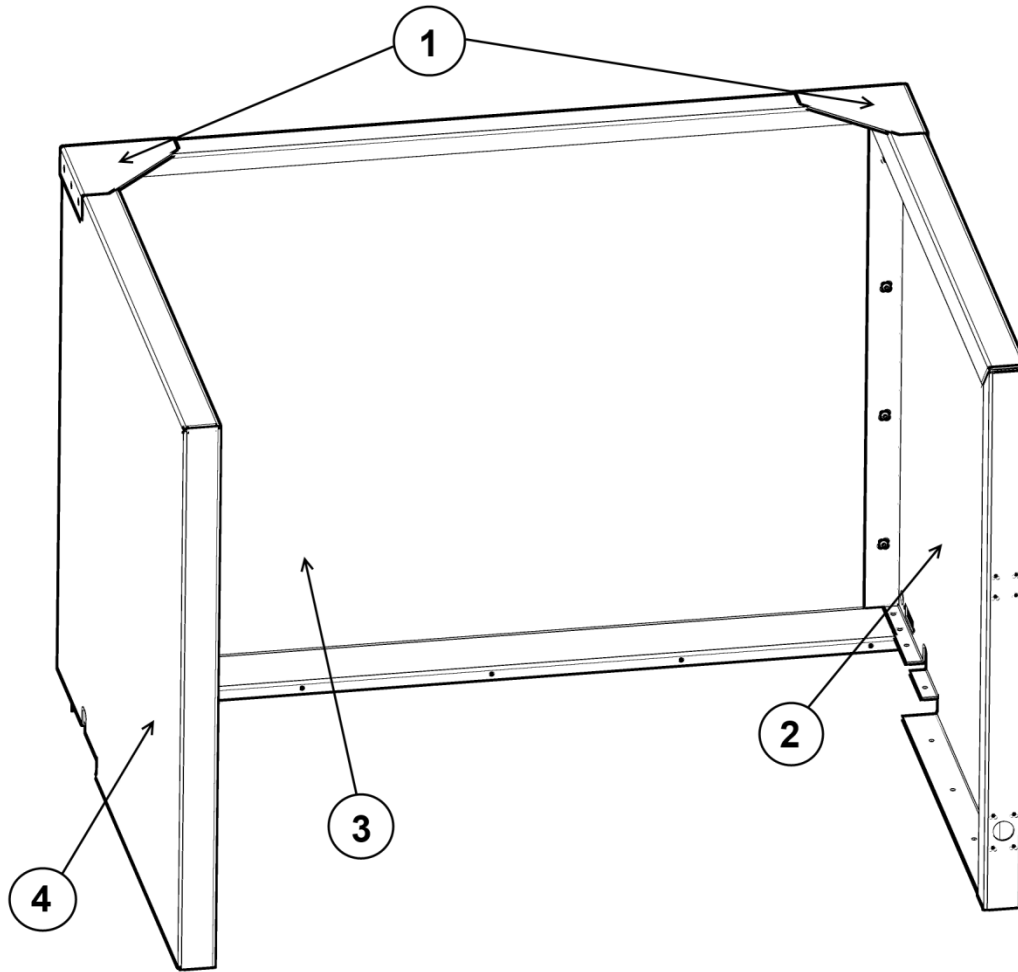

514-13-25 TANK ENCLOSURE PARTS			
ITEM	PART NUMBER	DESCRIPTION	QTY
1	514-13-19Q	GUSSET	1
2	514-13-19B	RIGHT SECTION	1
3	514-13-19A	BACK SECTION	1
4	514-13-19C	LEFT SECTION	1

**X-Axis Assembly 514-13-67 (H75X only)**

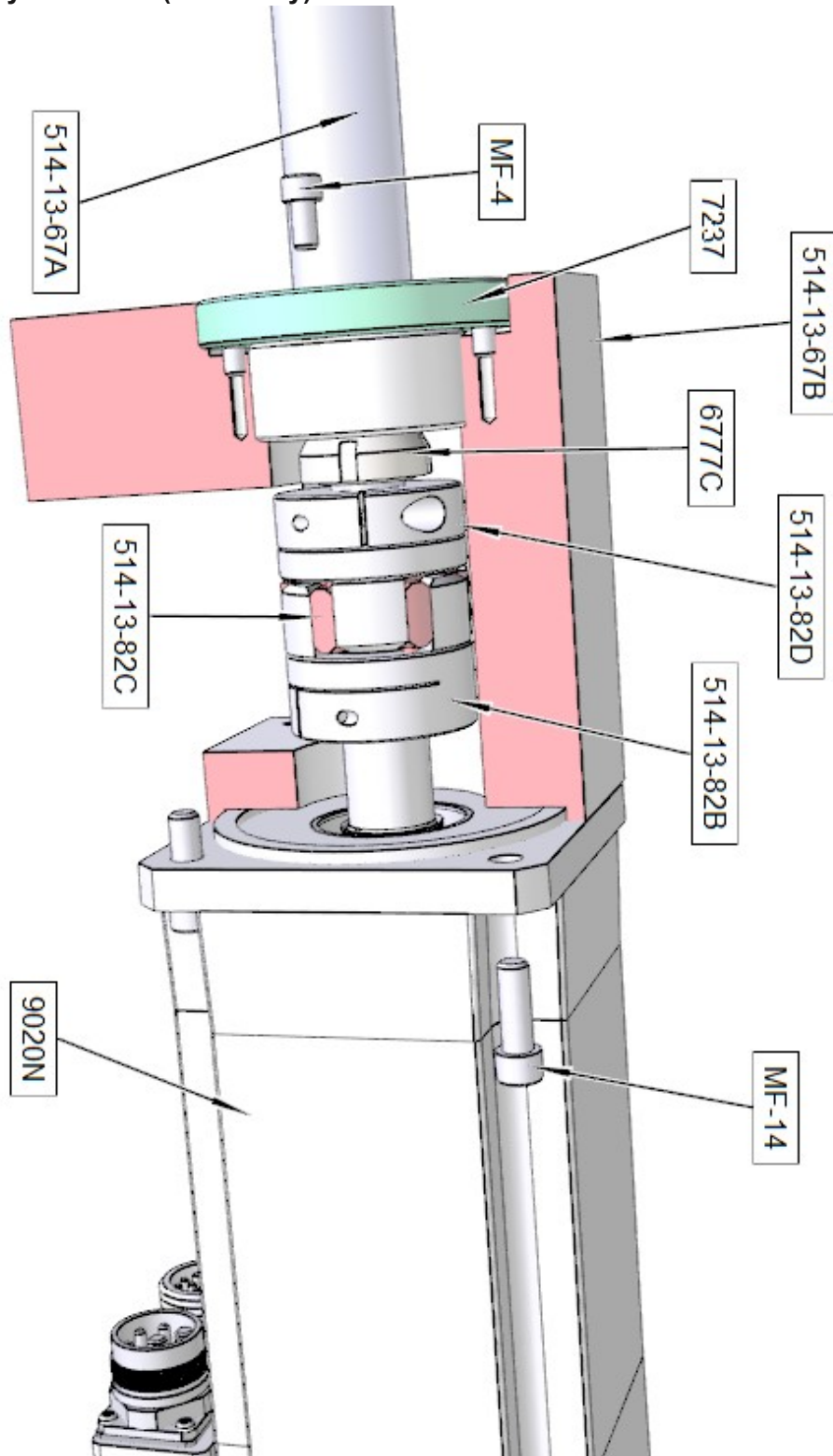

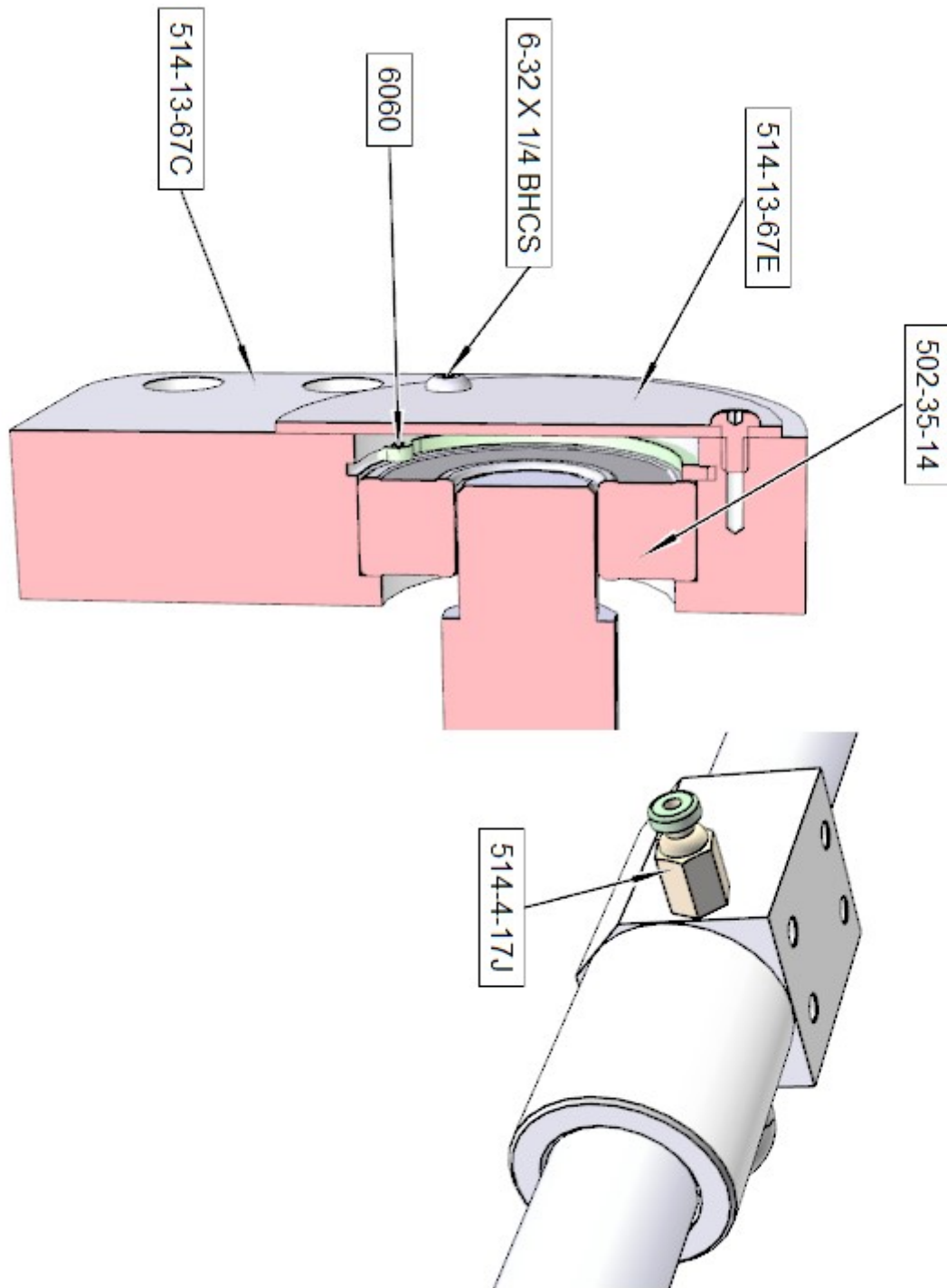

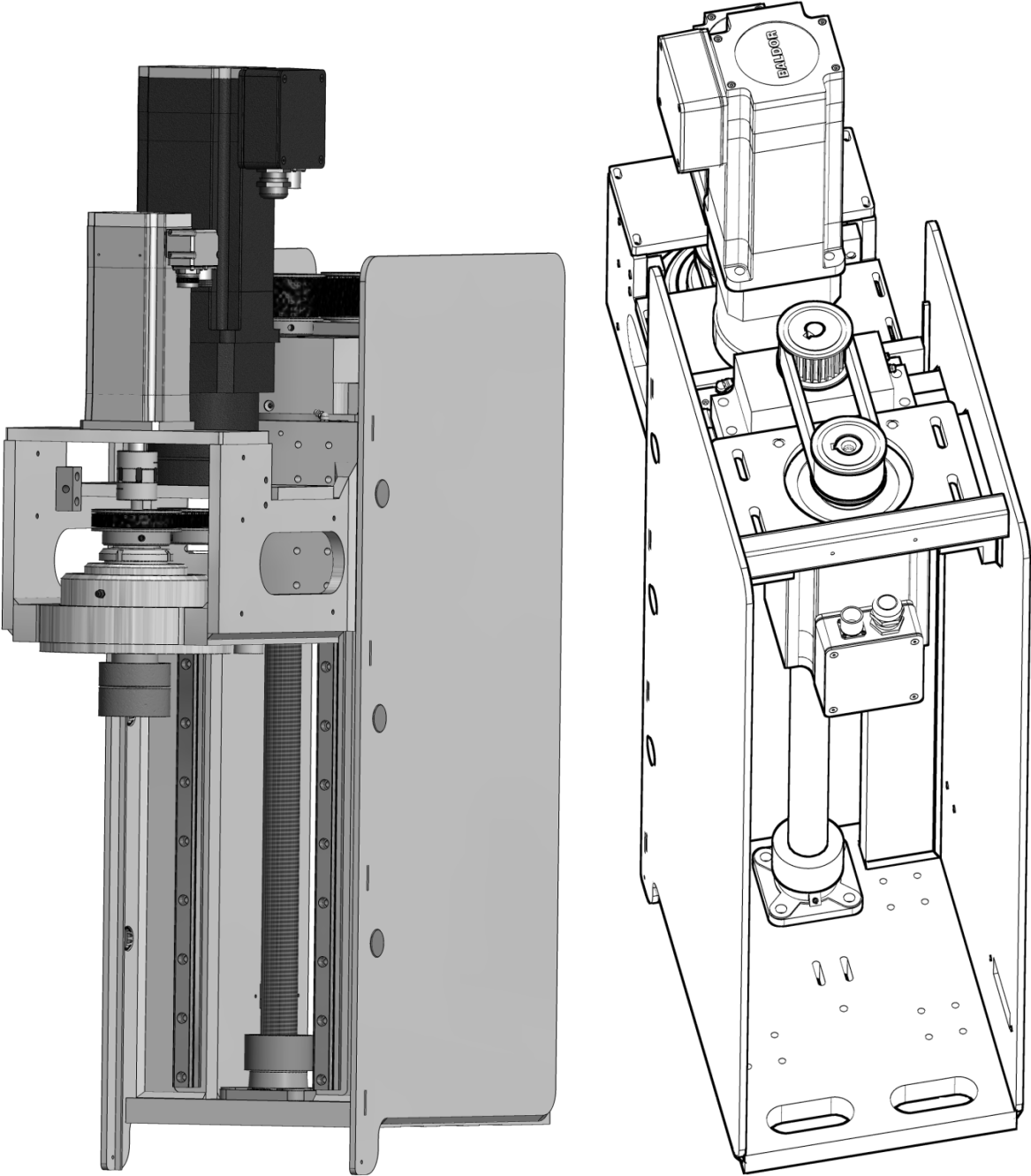

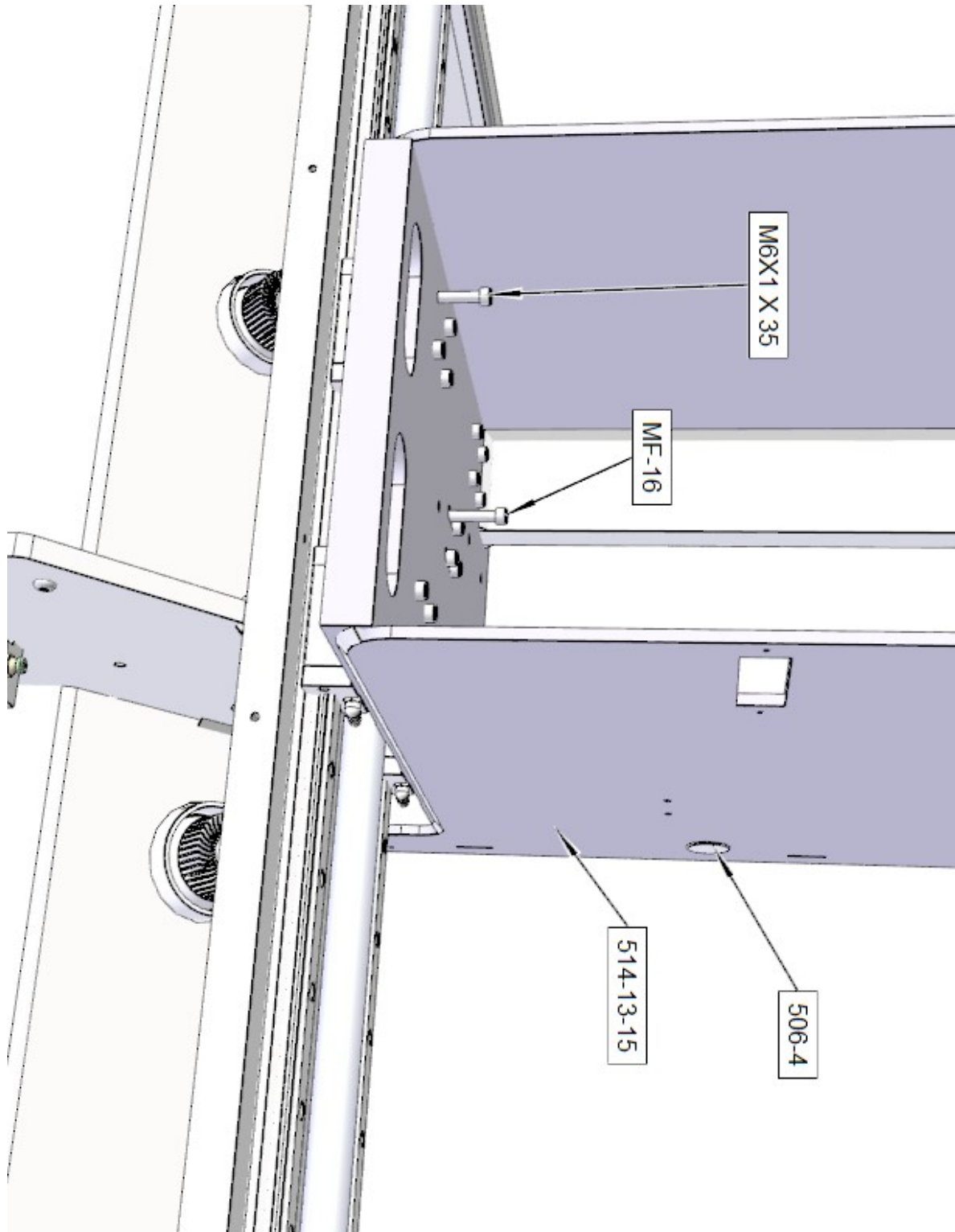

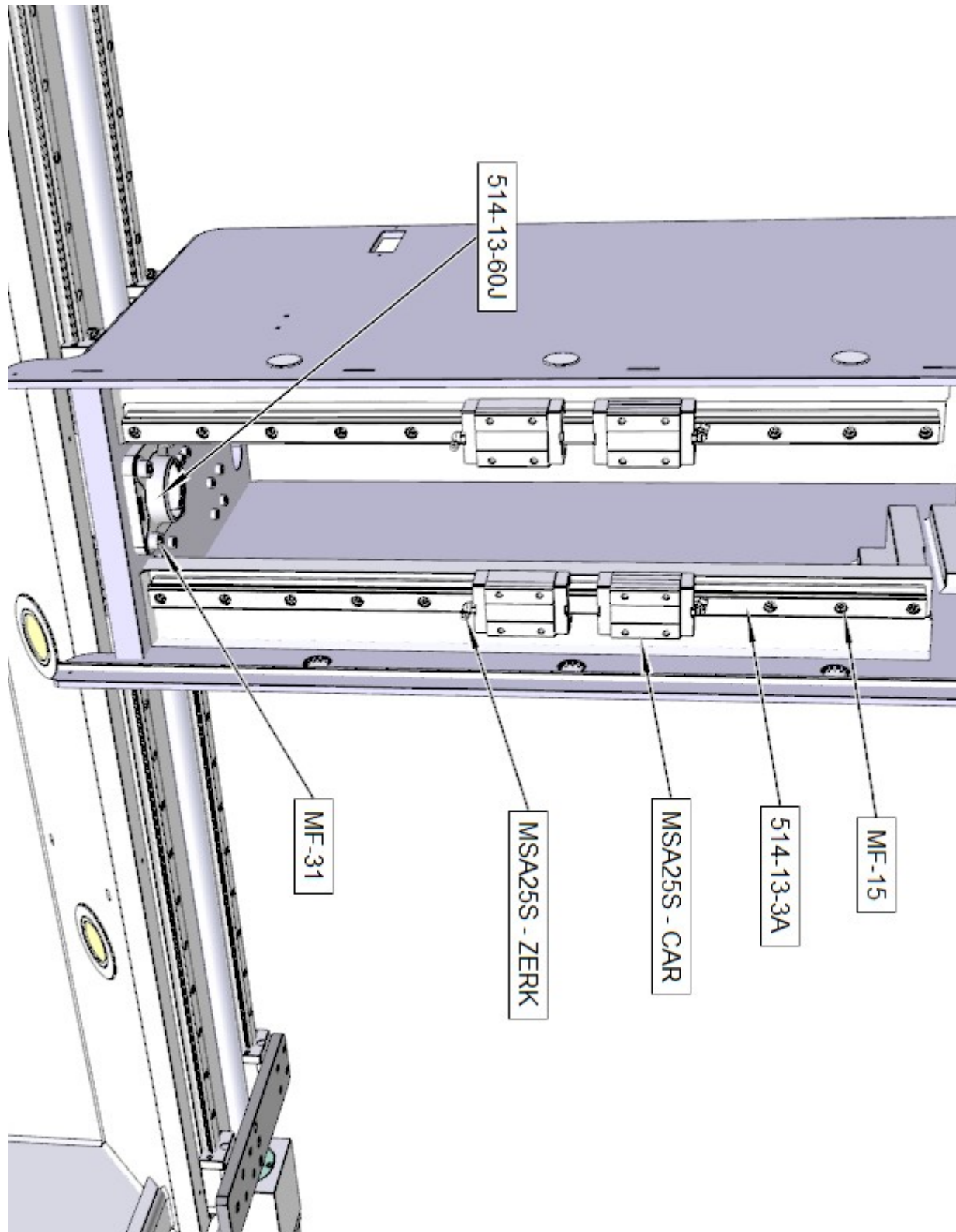



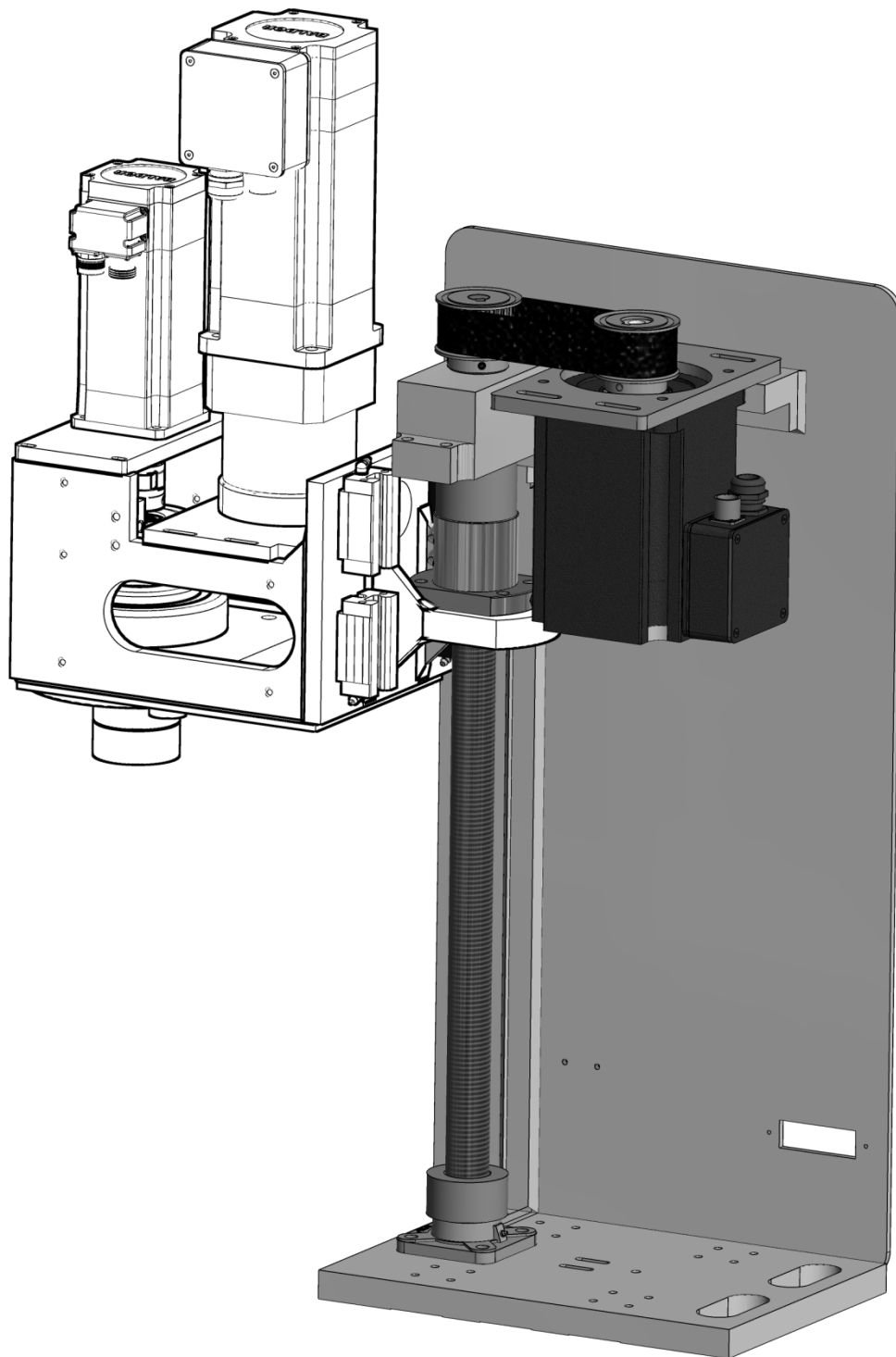

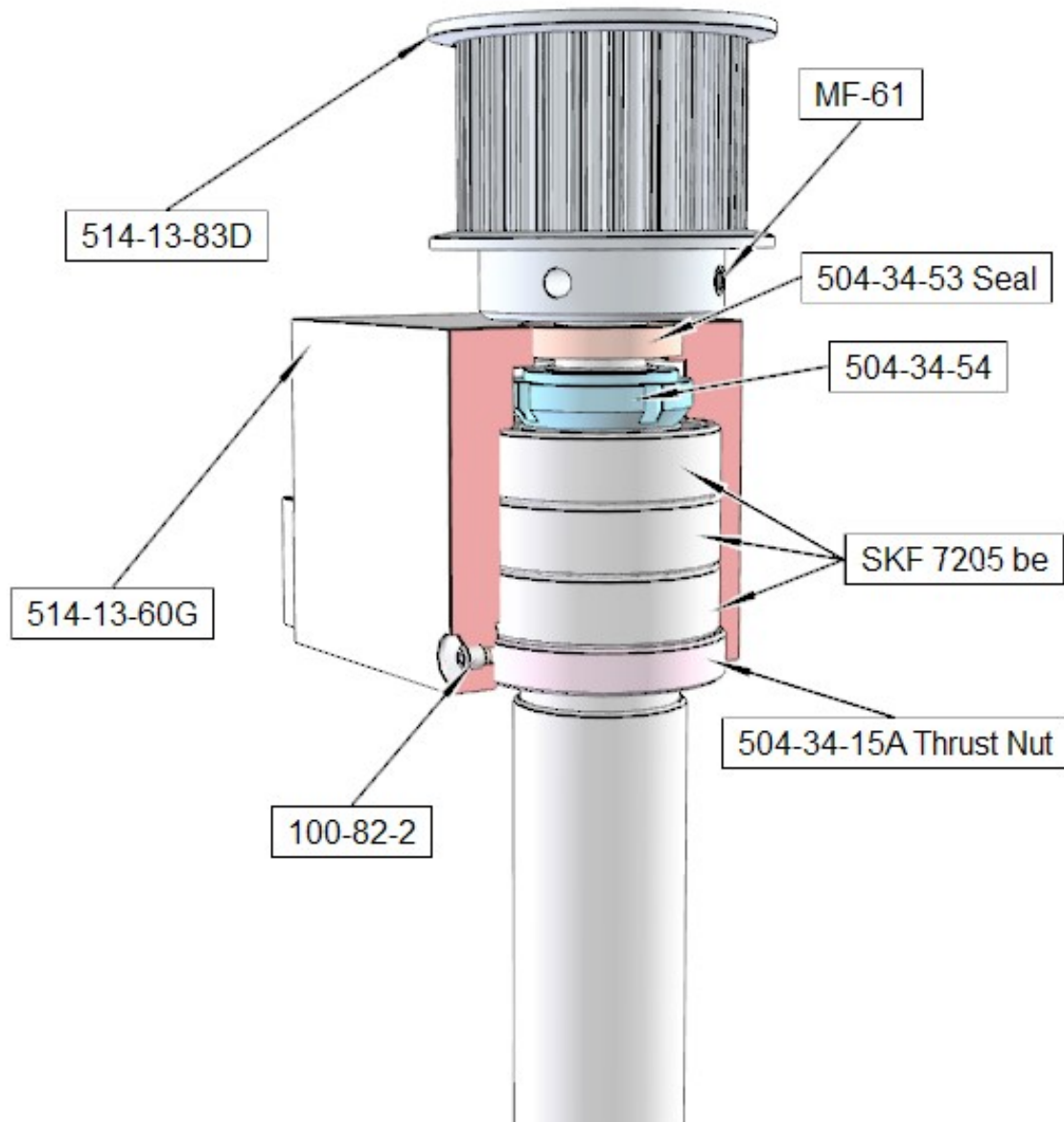

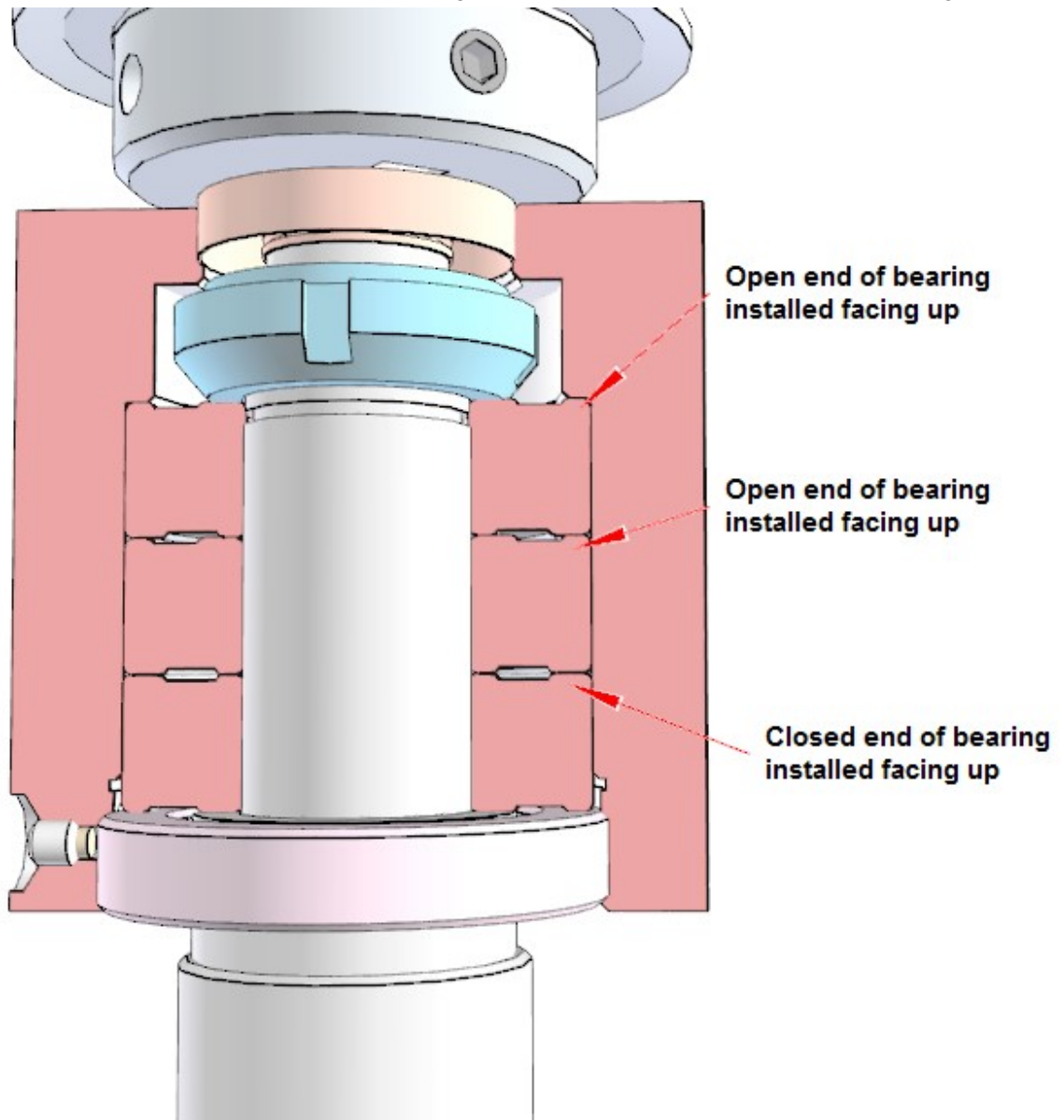

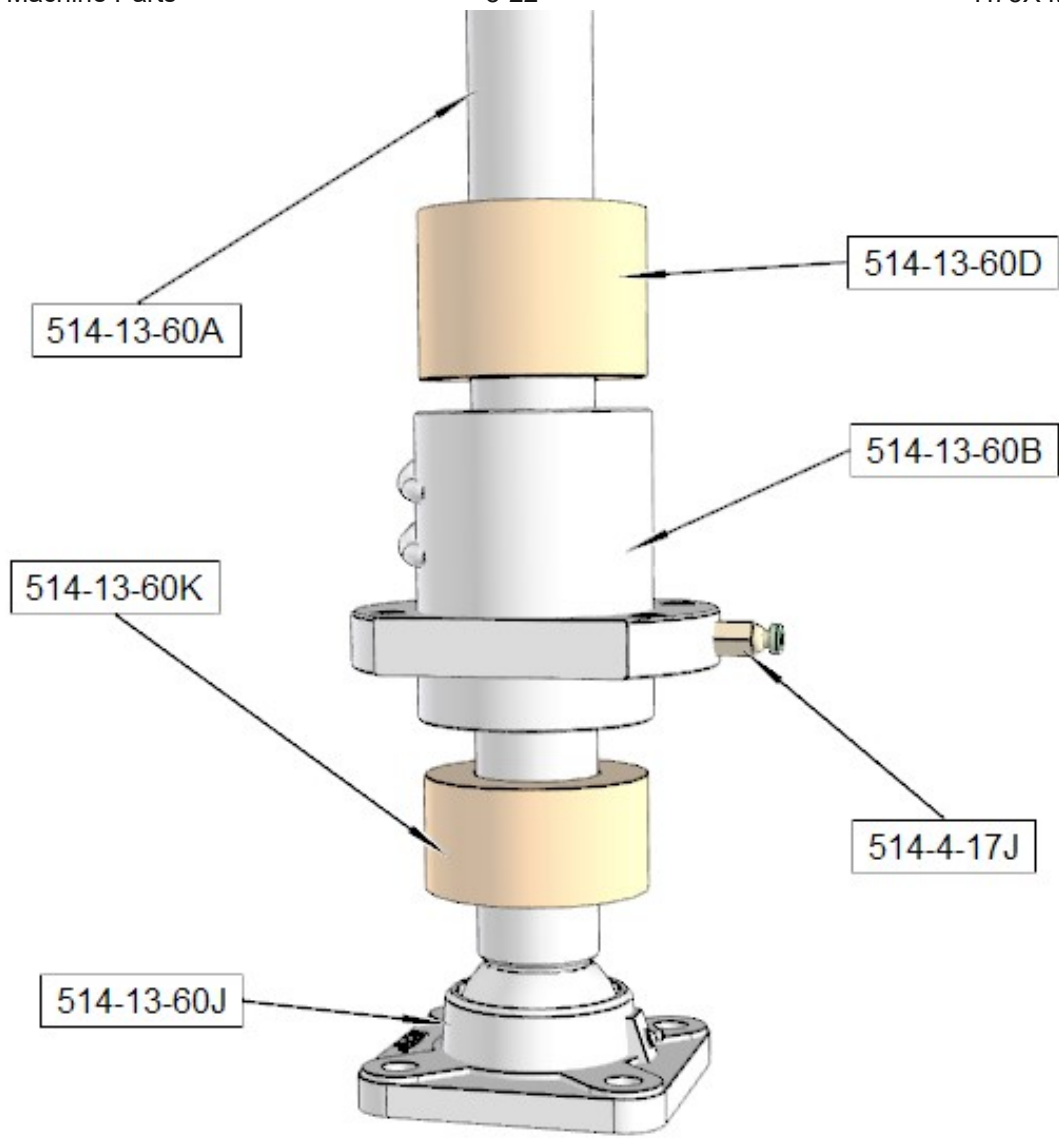

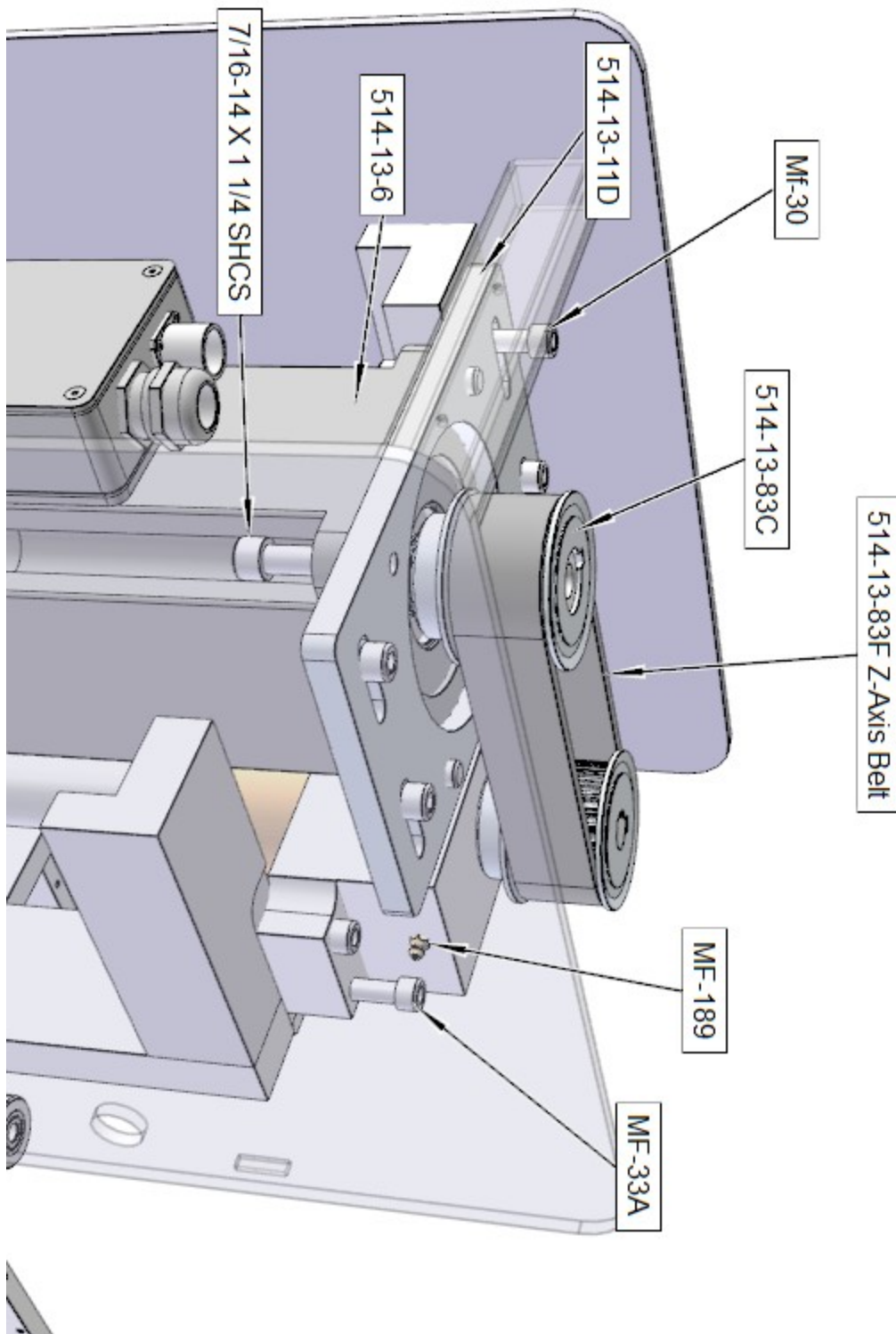

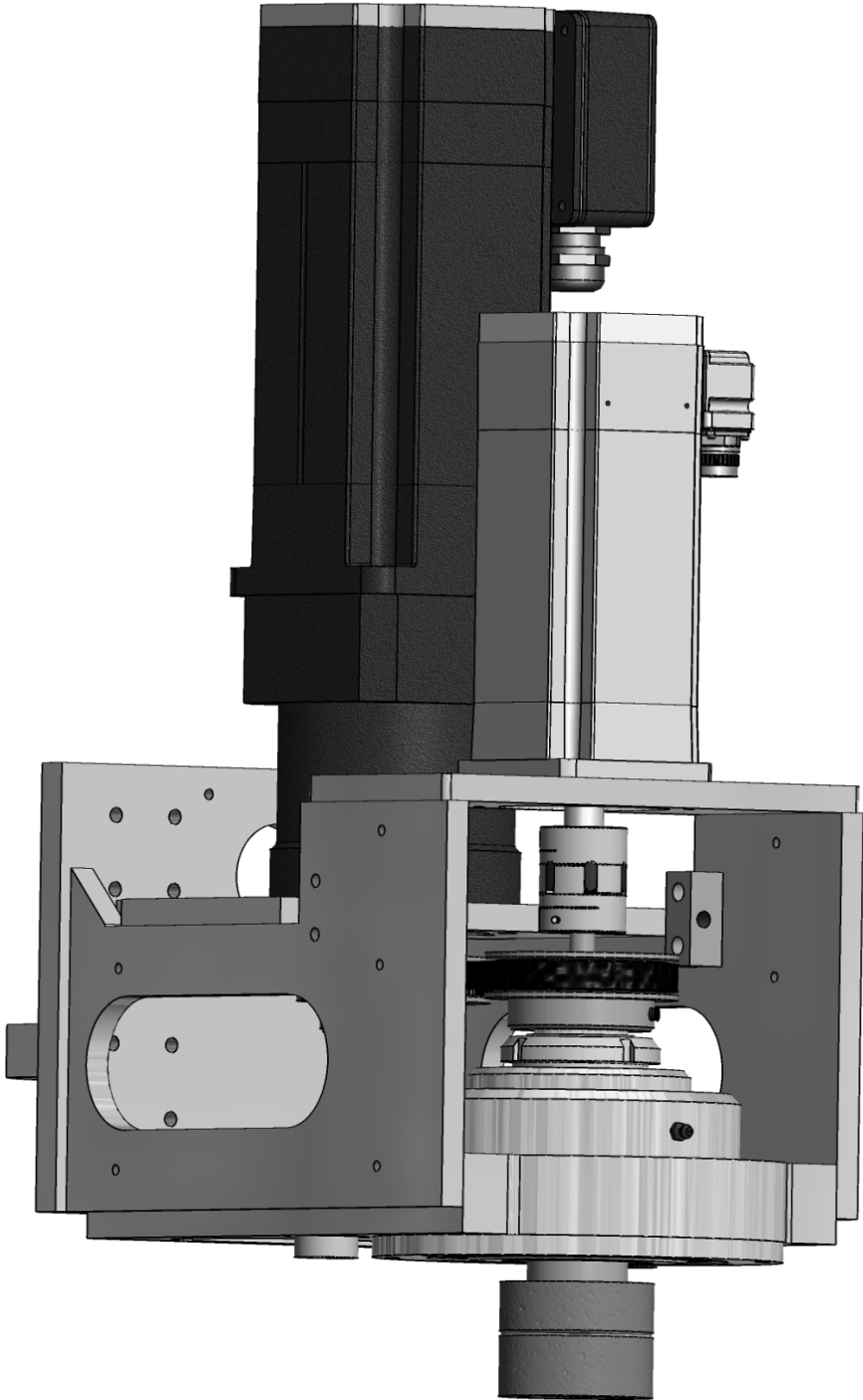

**Motor and Hub Housing Assembly Components**

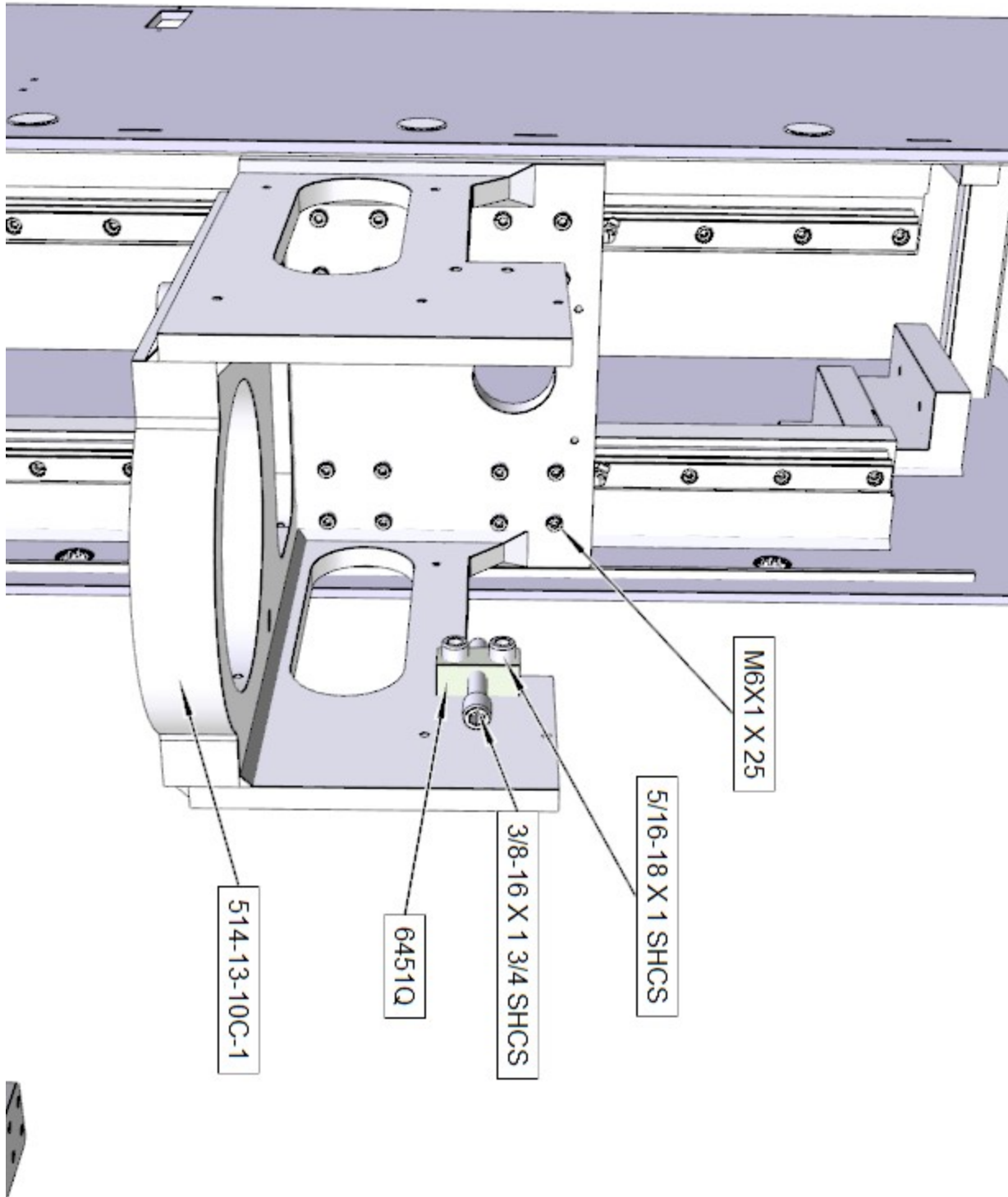

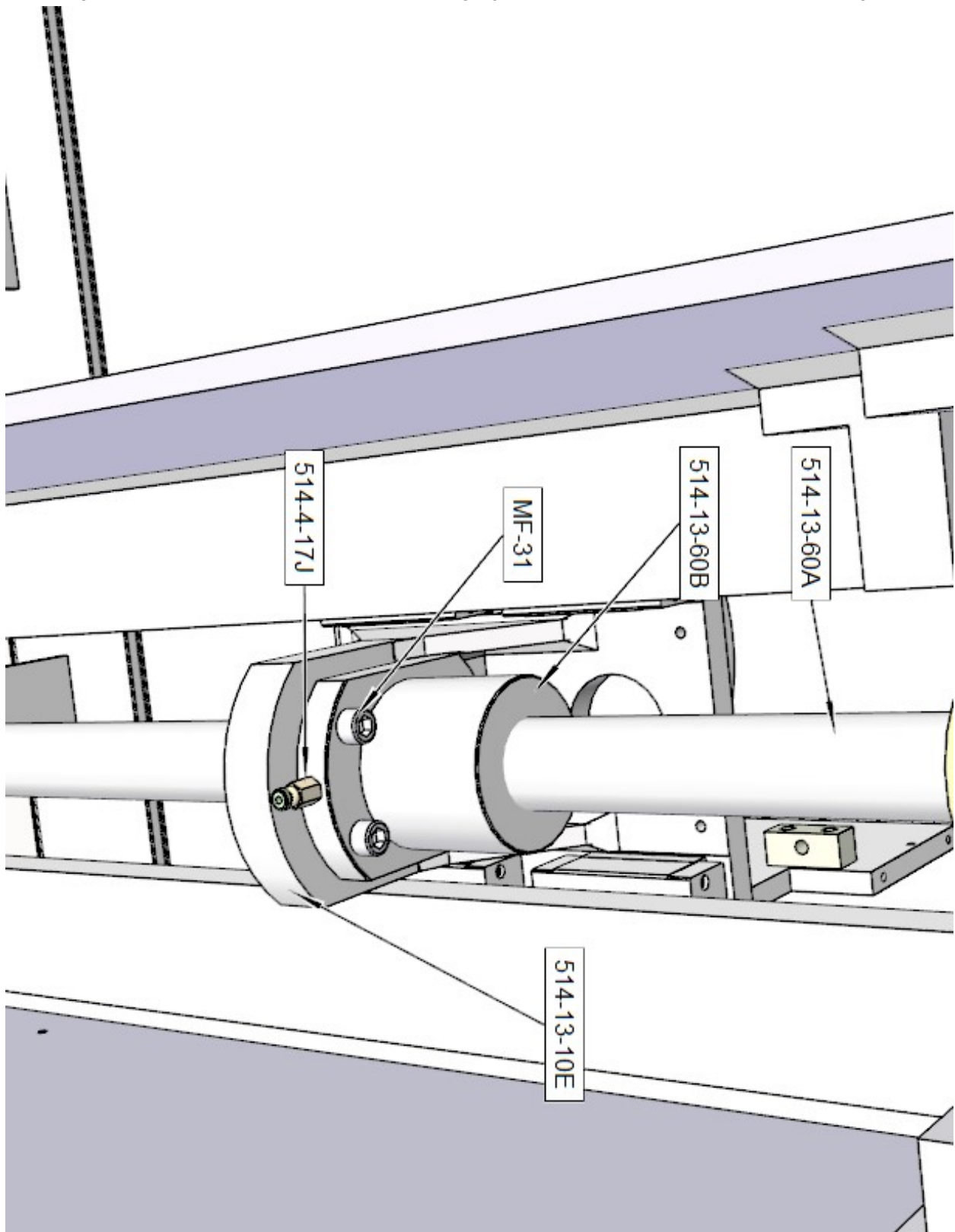



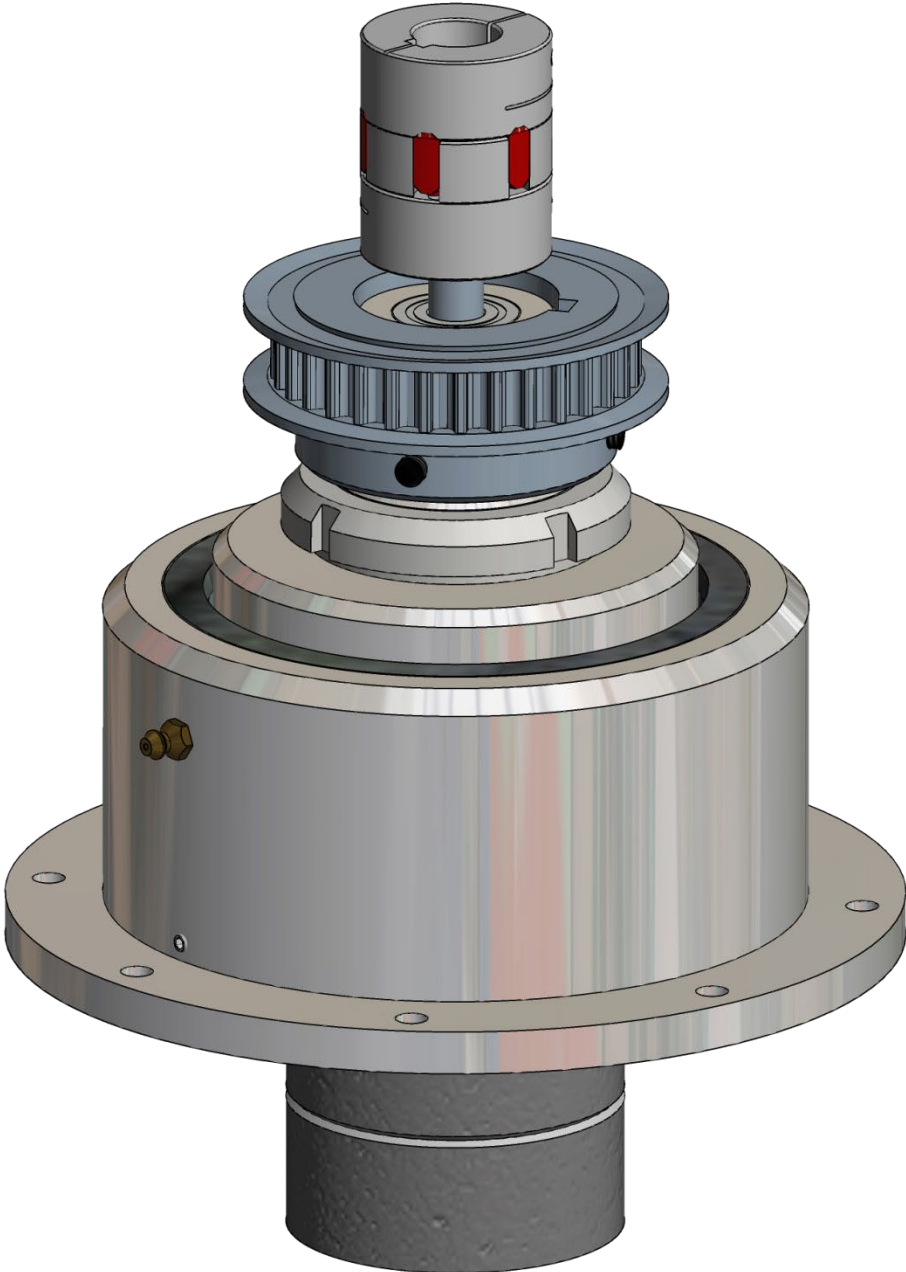

**Spindle Drive Assembly Components**

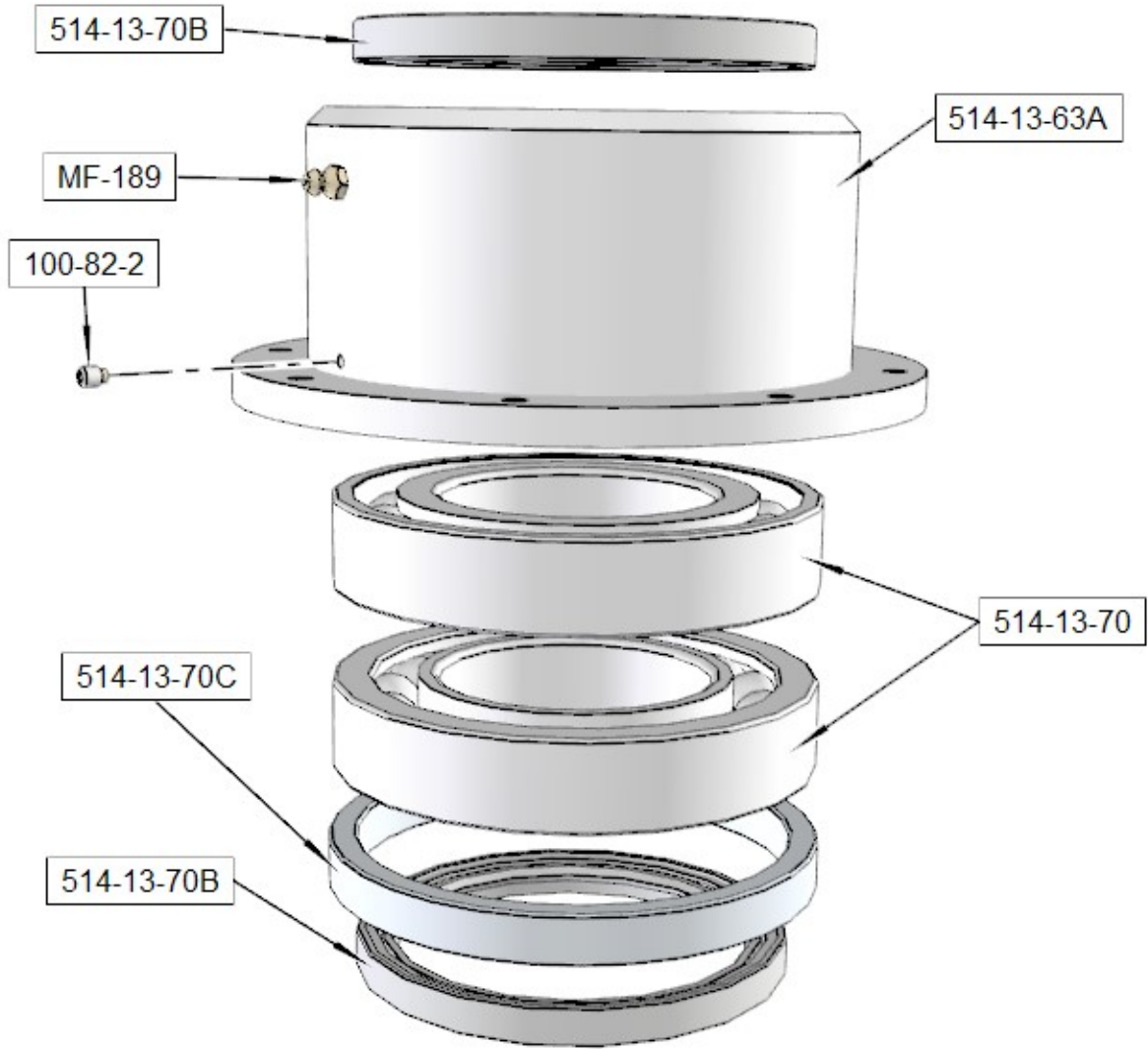

**Spindle Drive Bearing Install**

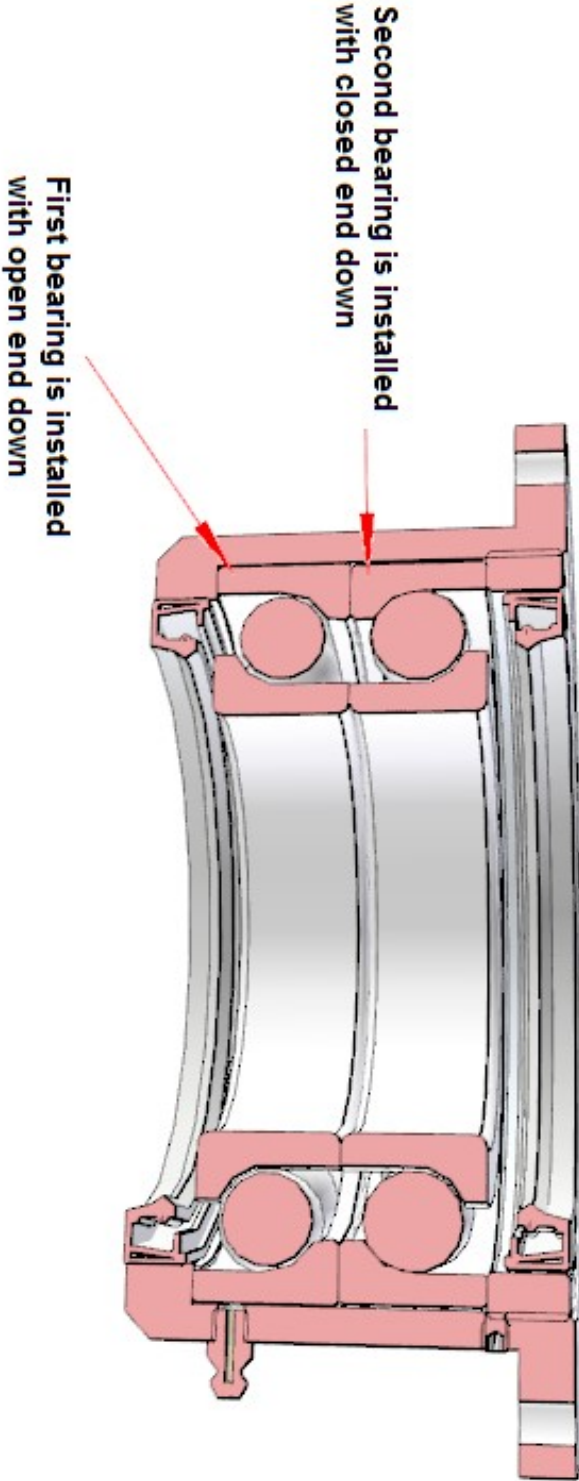

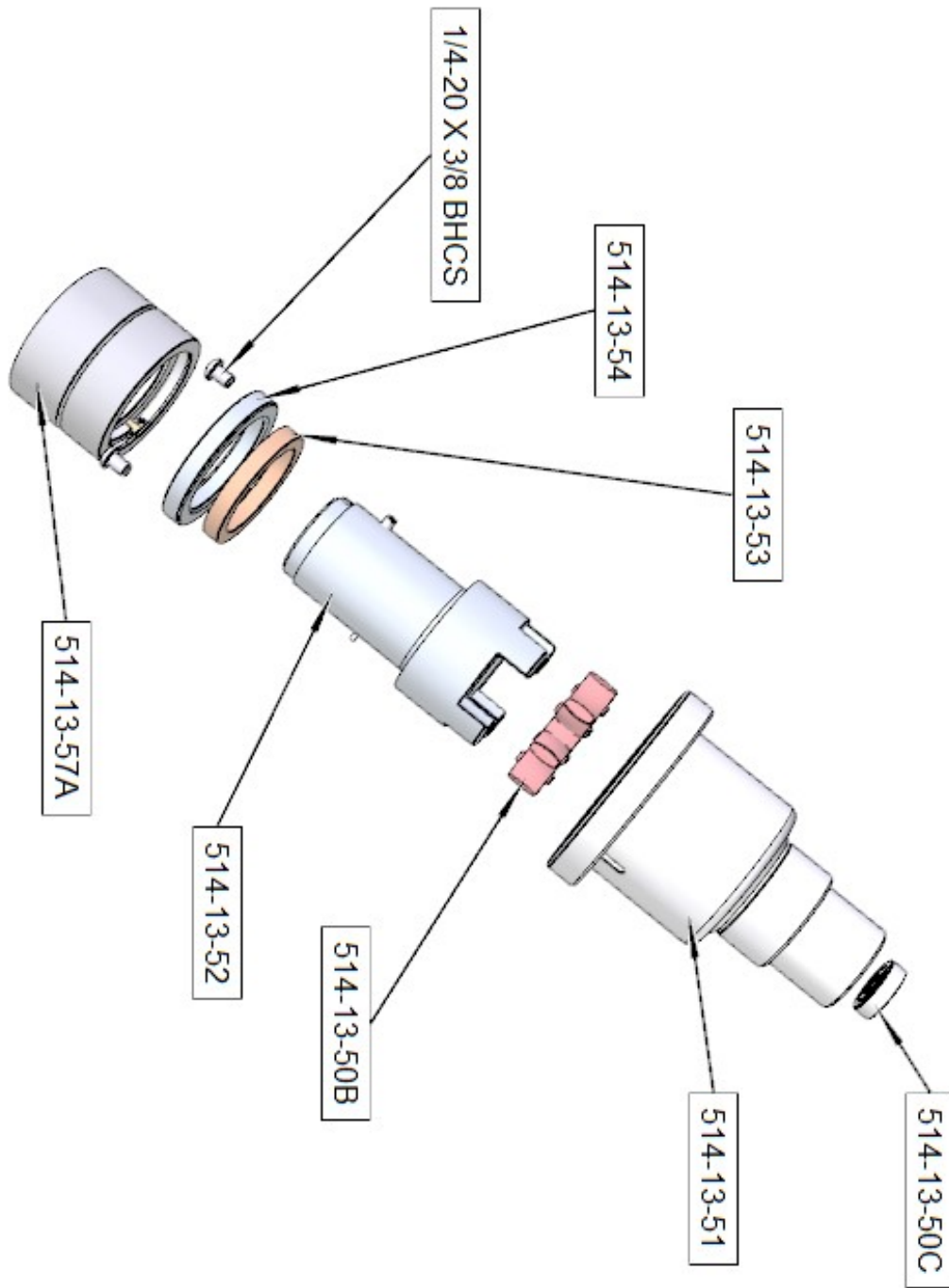

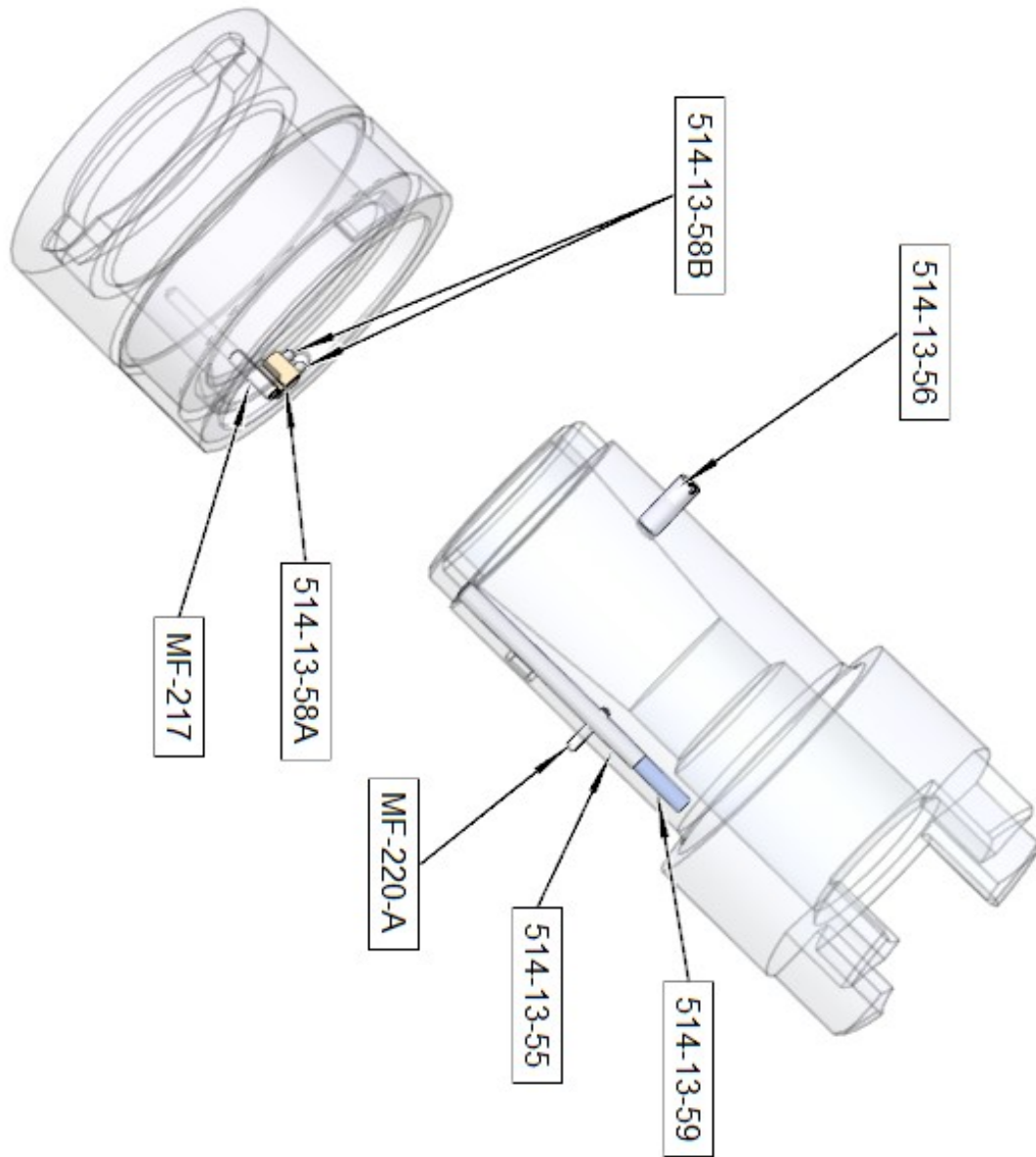

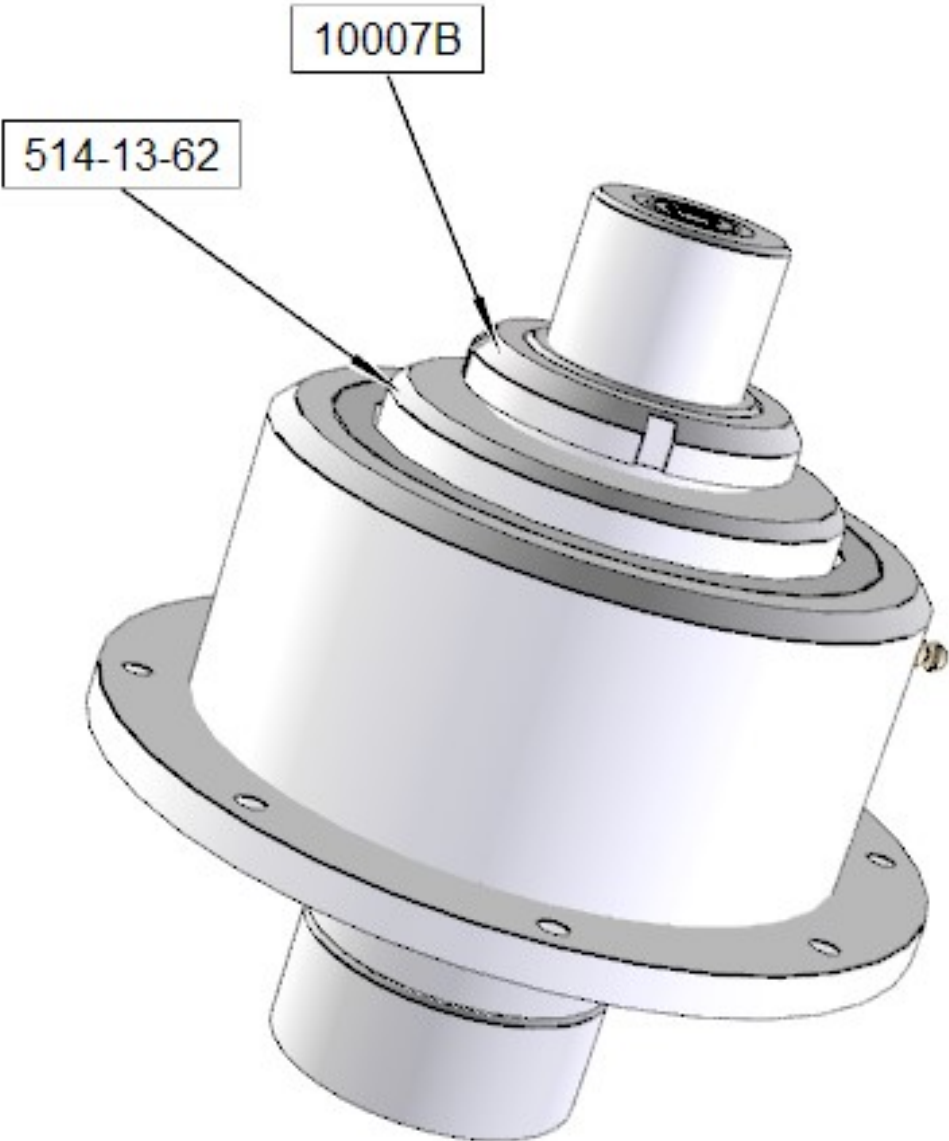

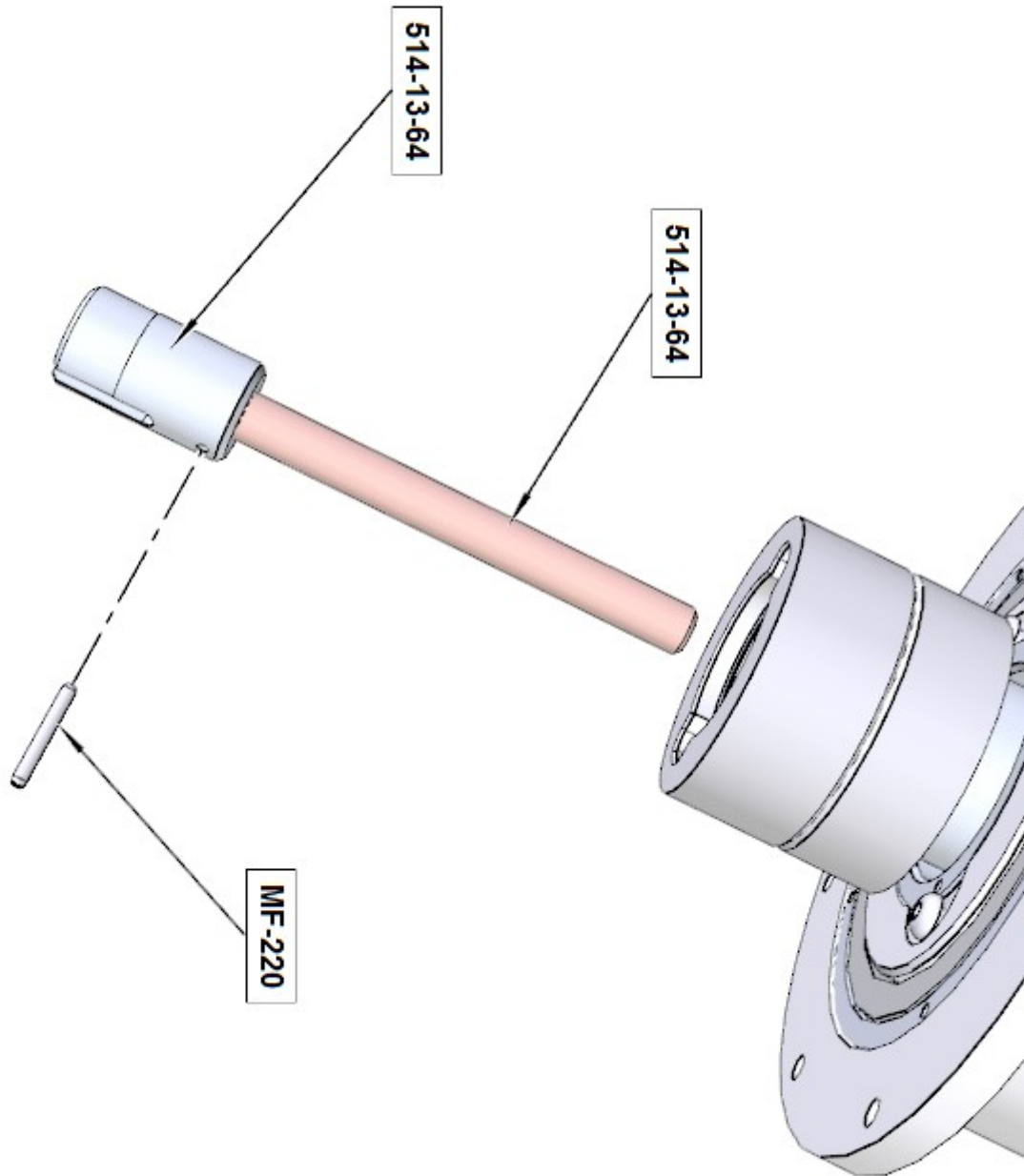

**Spindle Drive Mount and Work Lights**

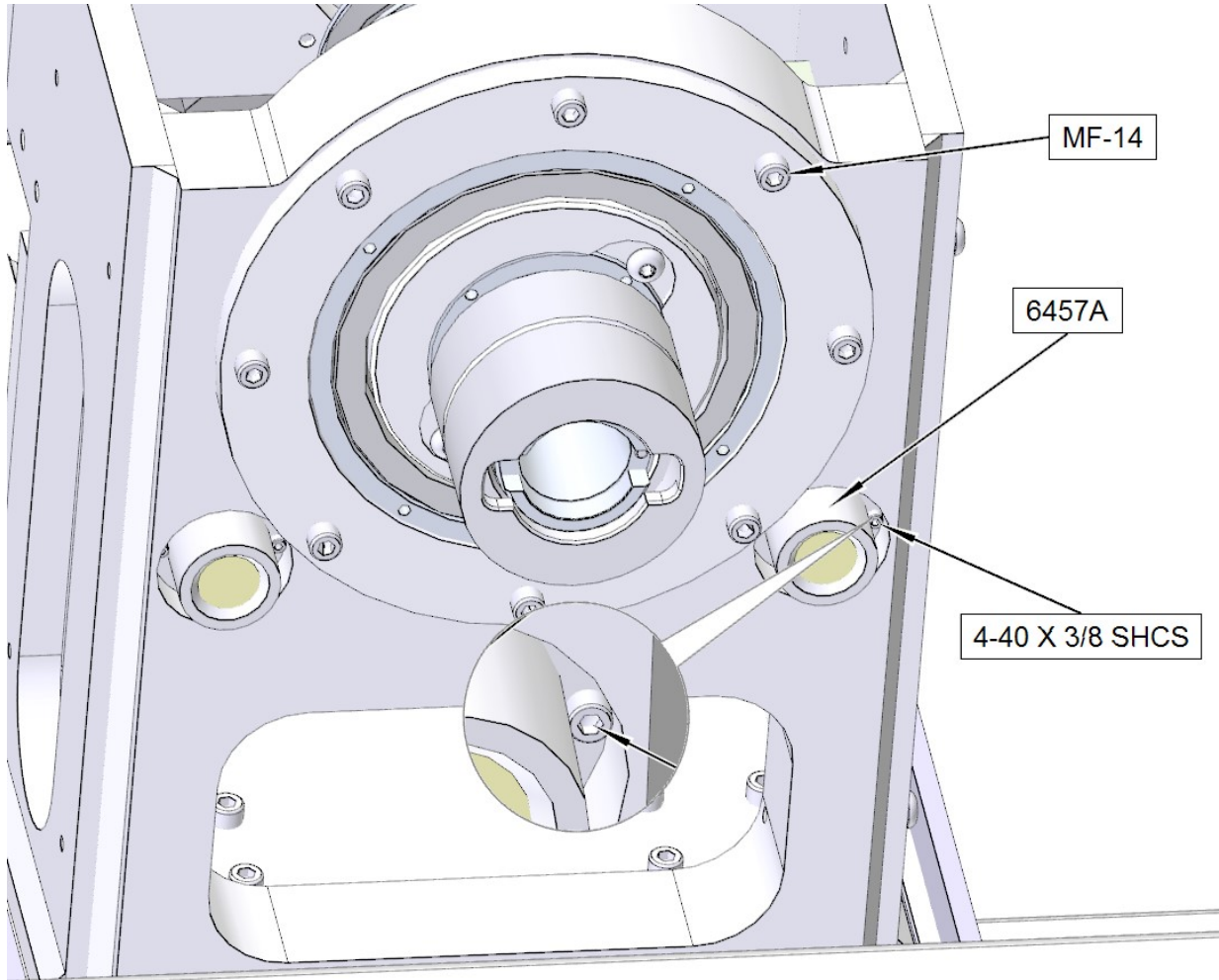



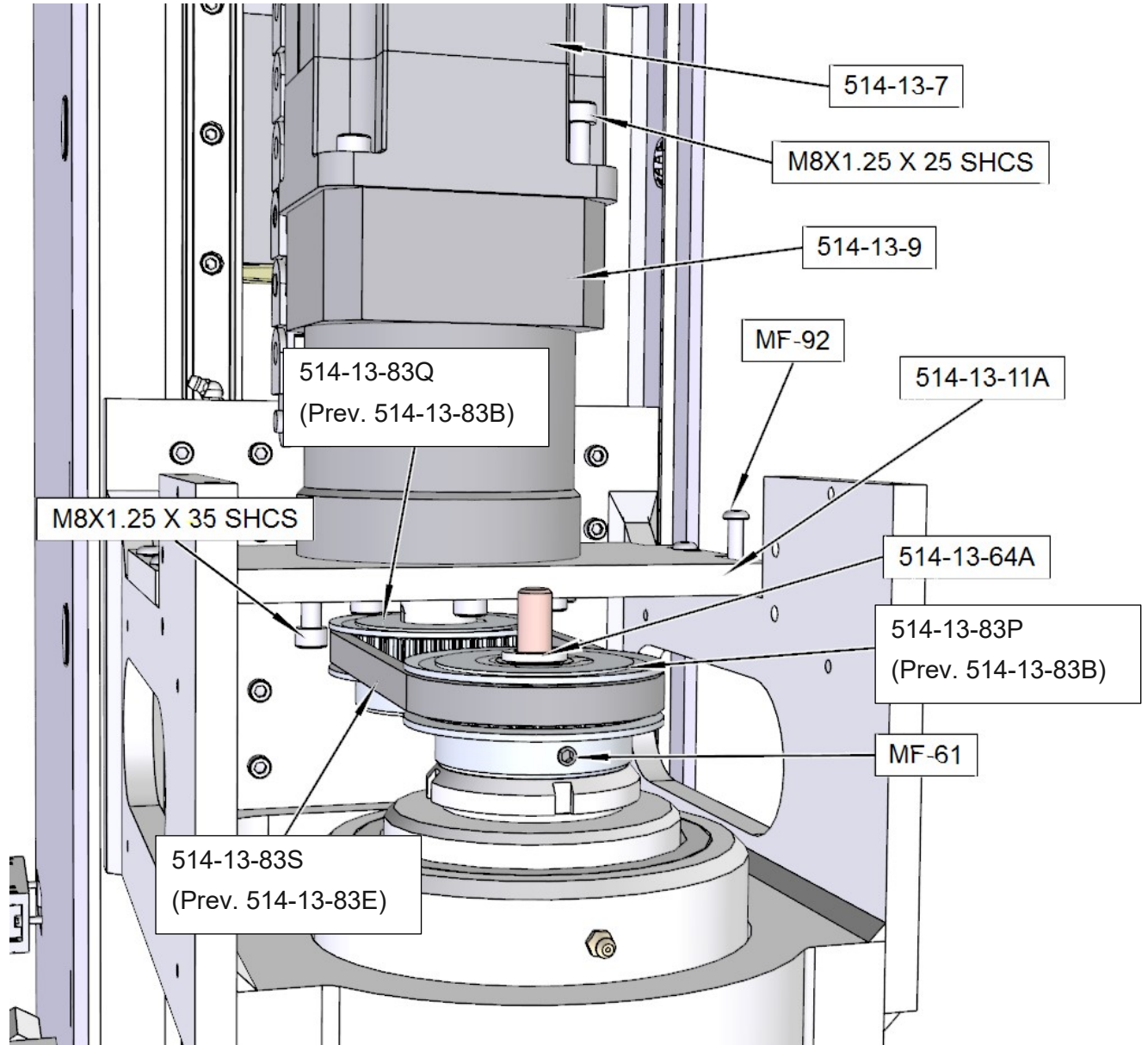

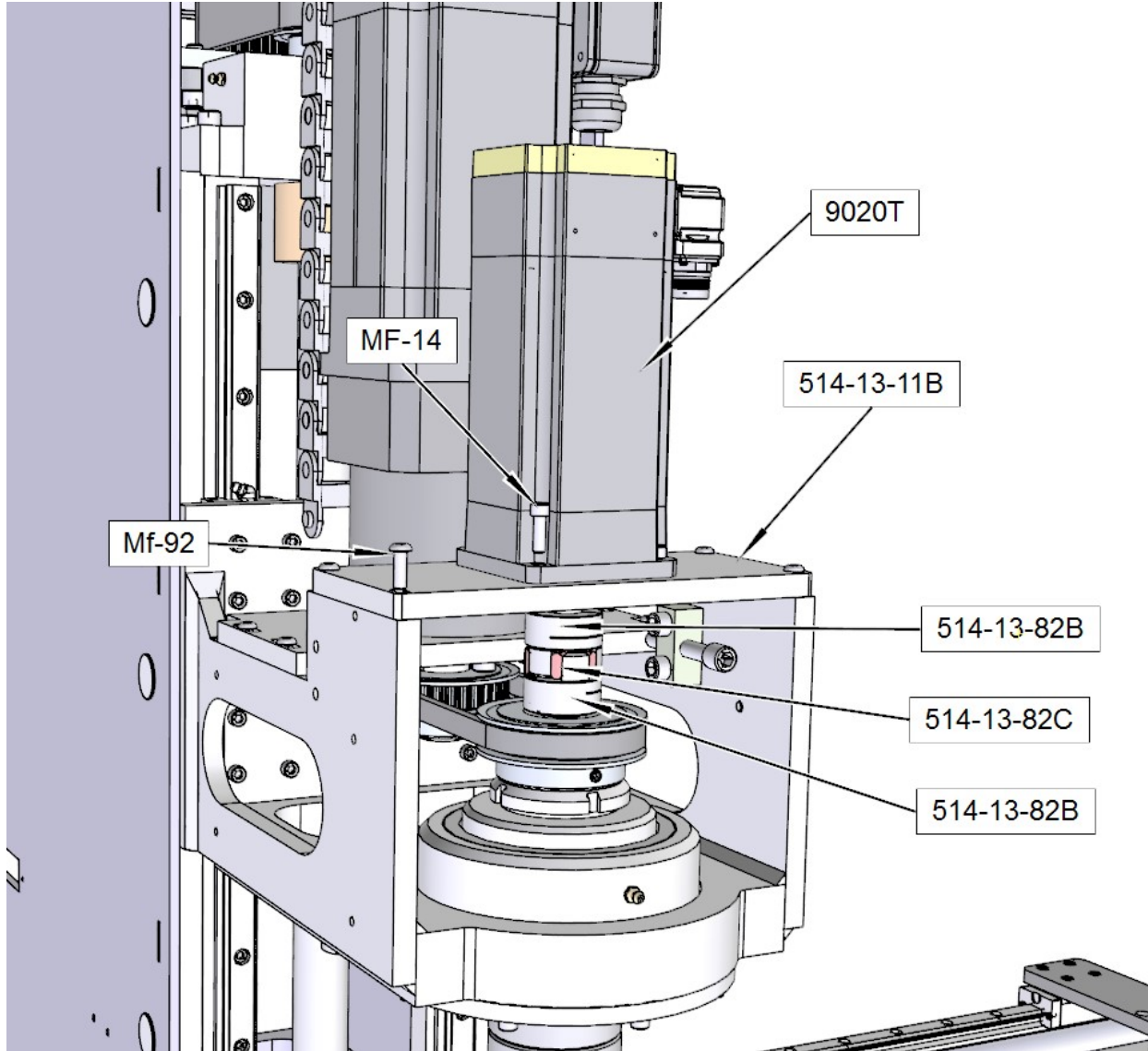

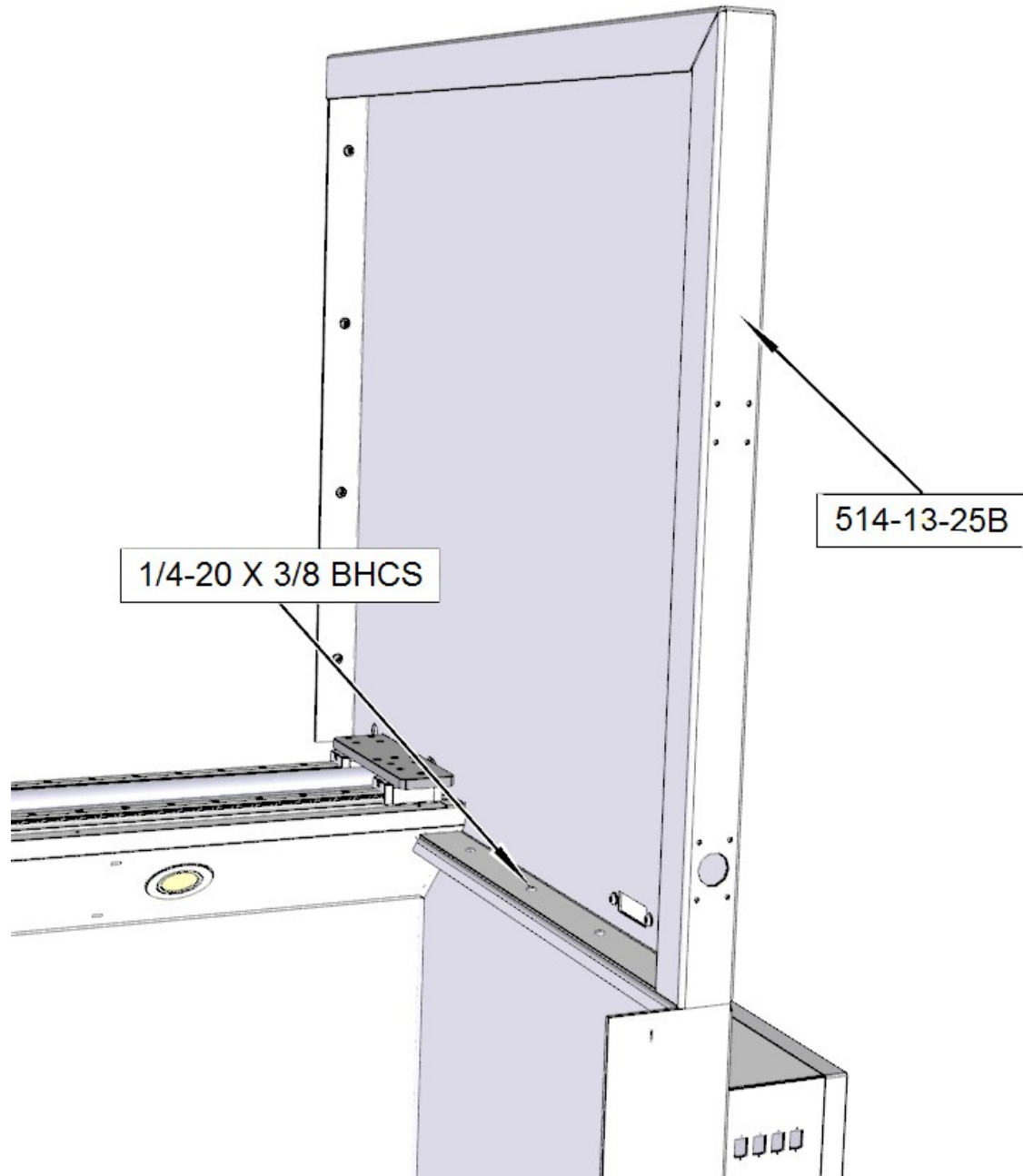

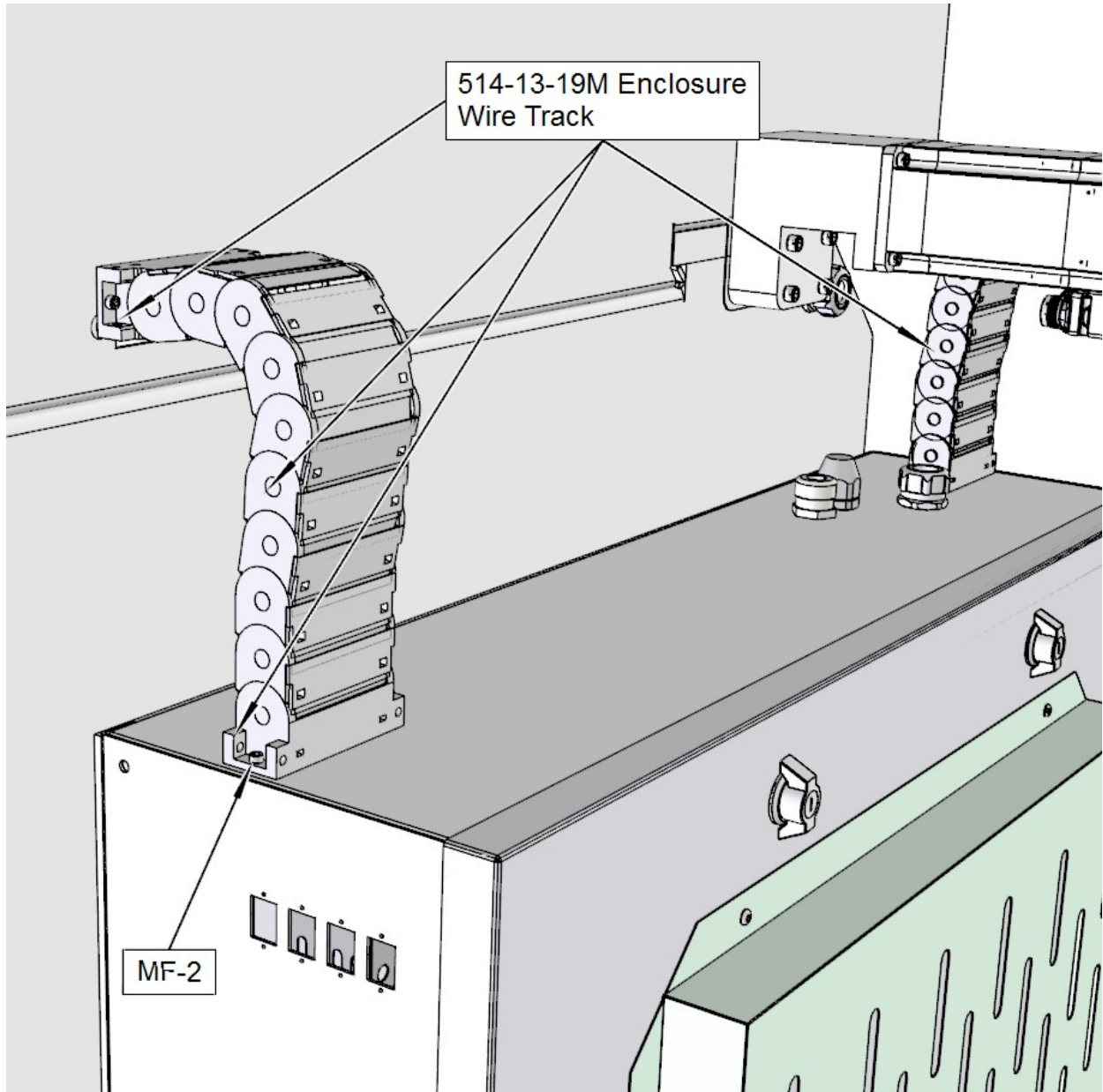

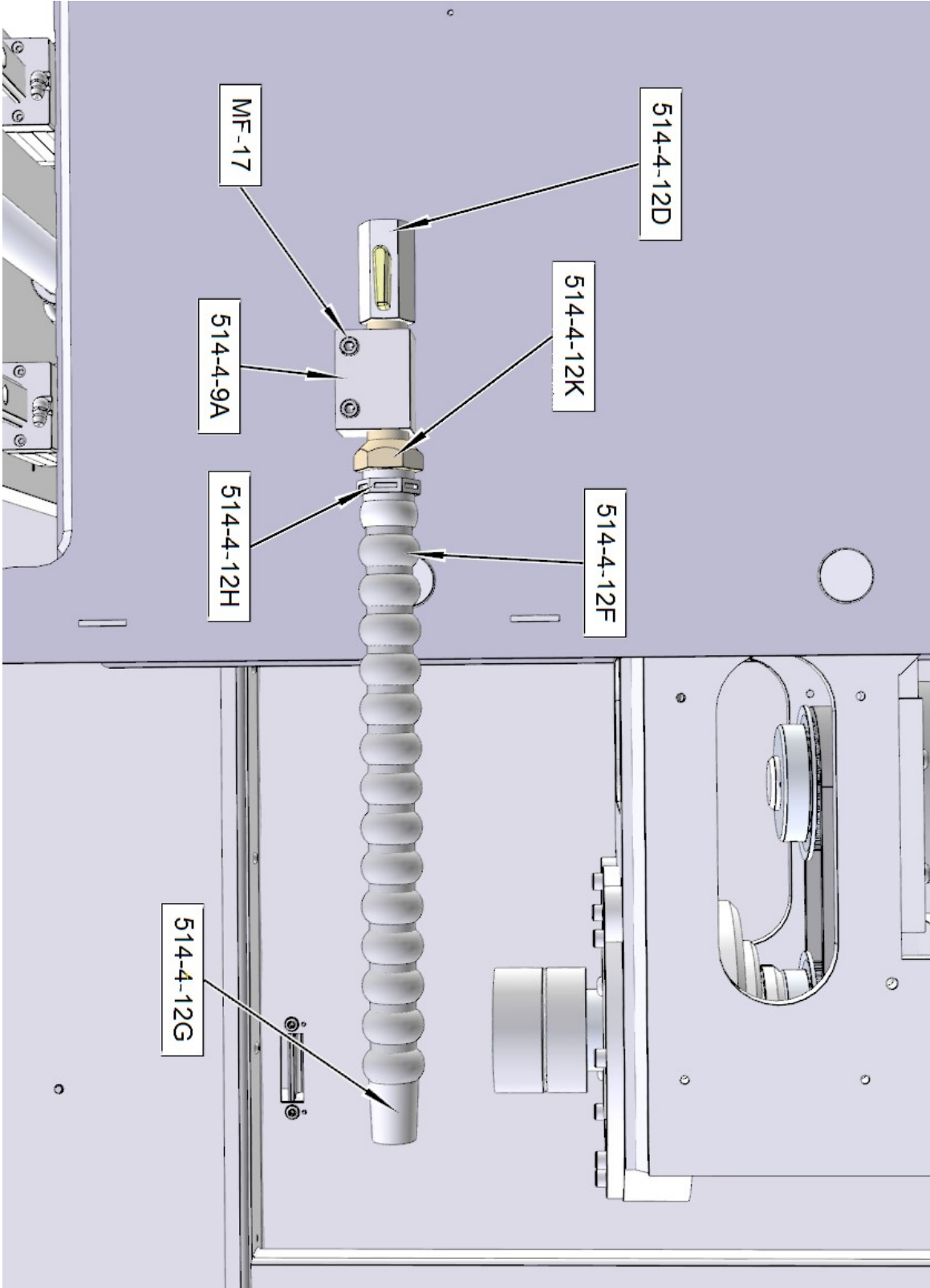

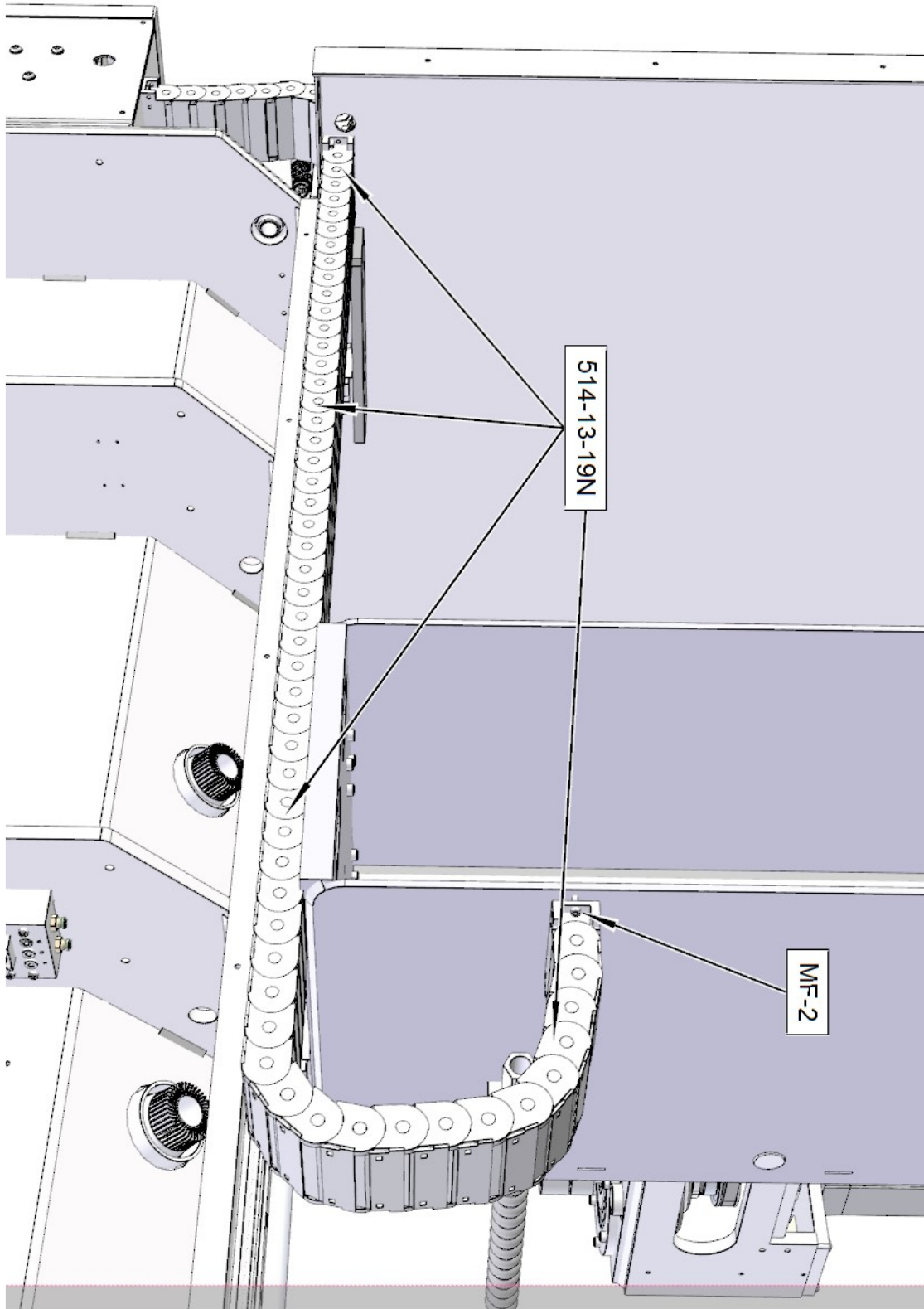

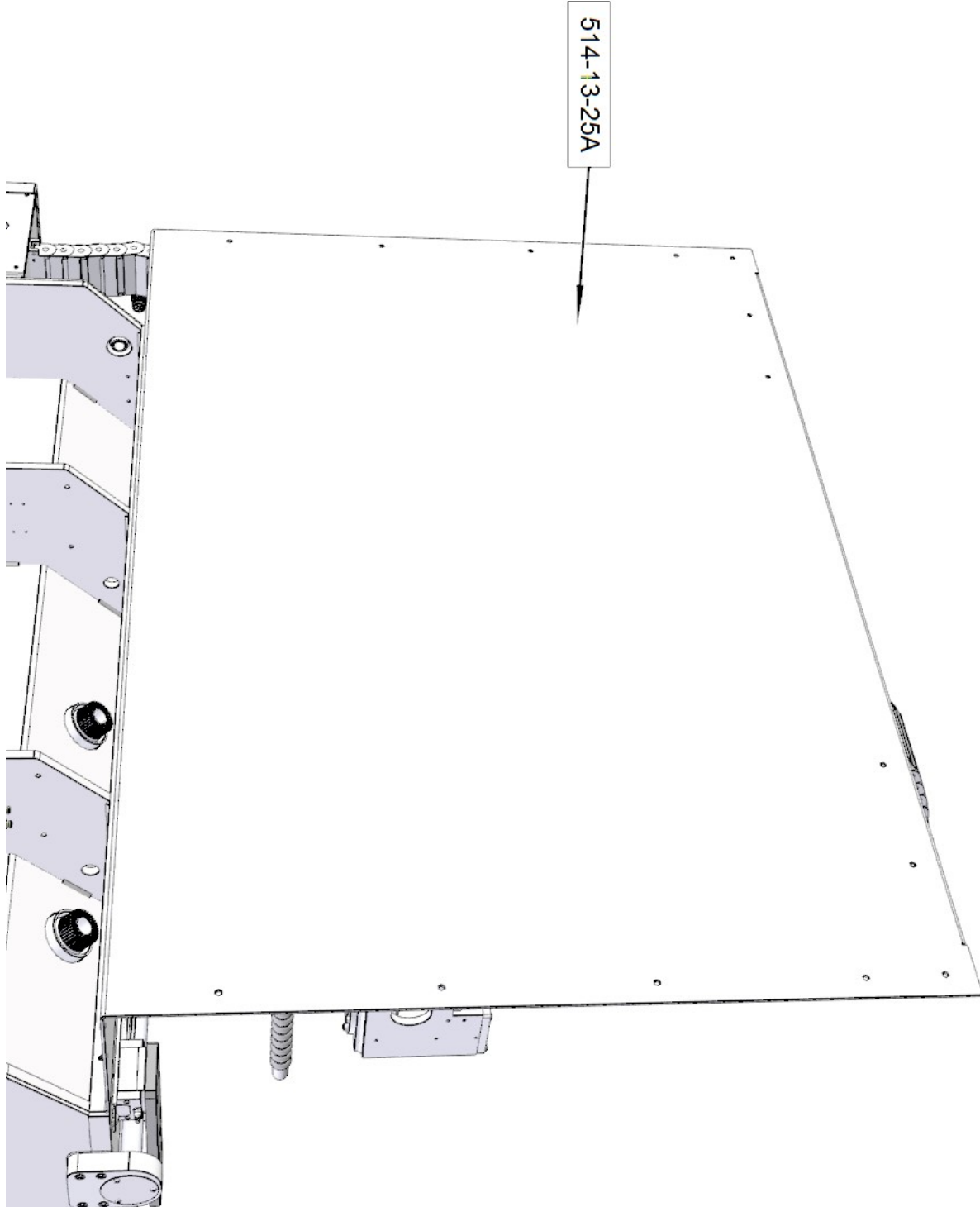

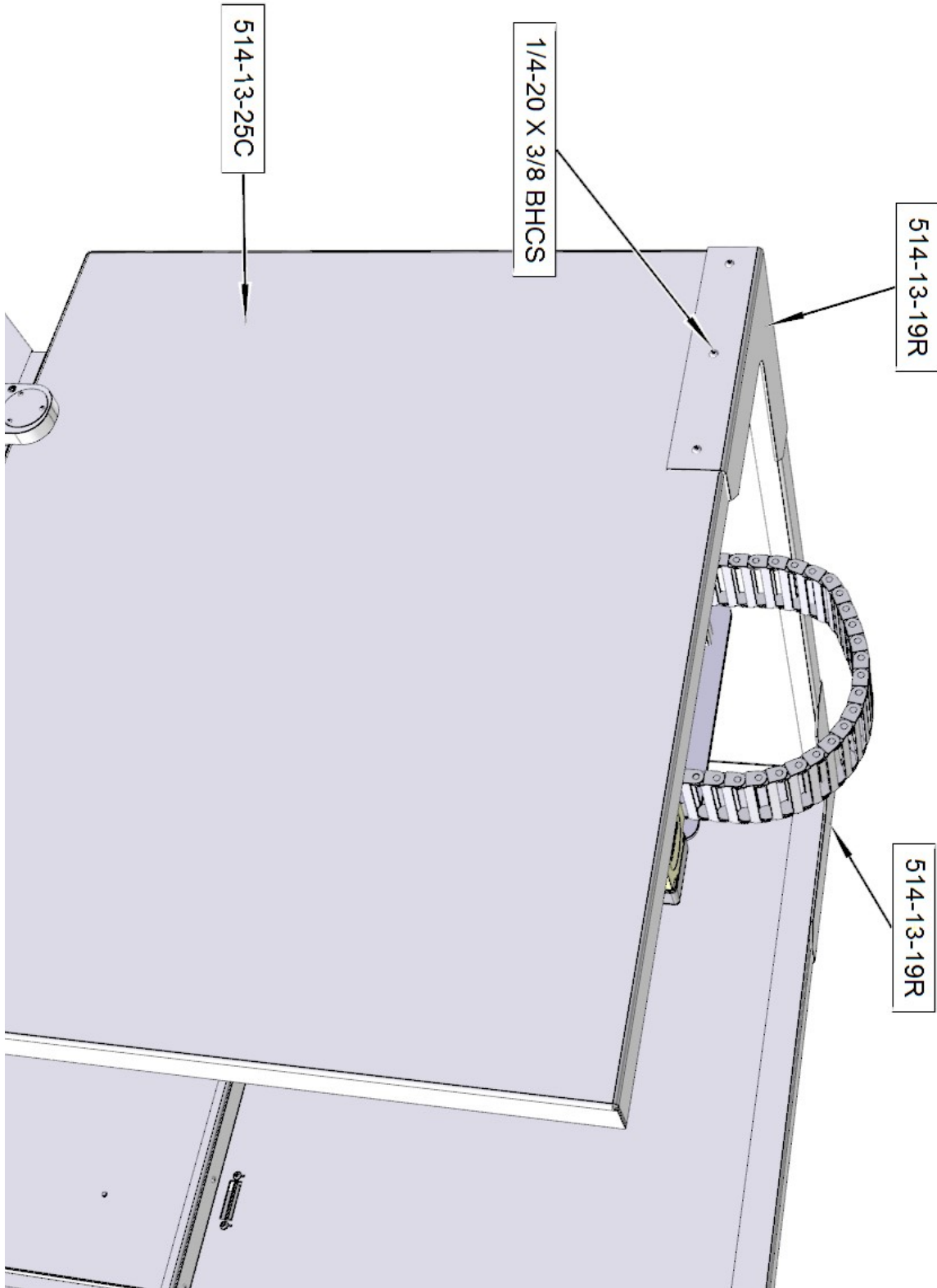



**Carriage Cover and Ballscrew Curtain**

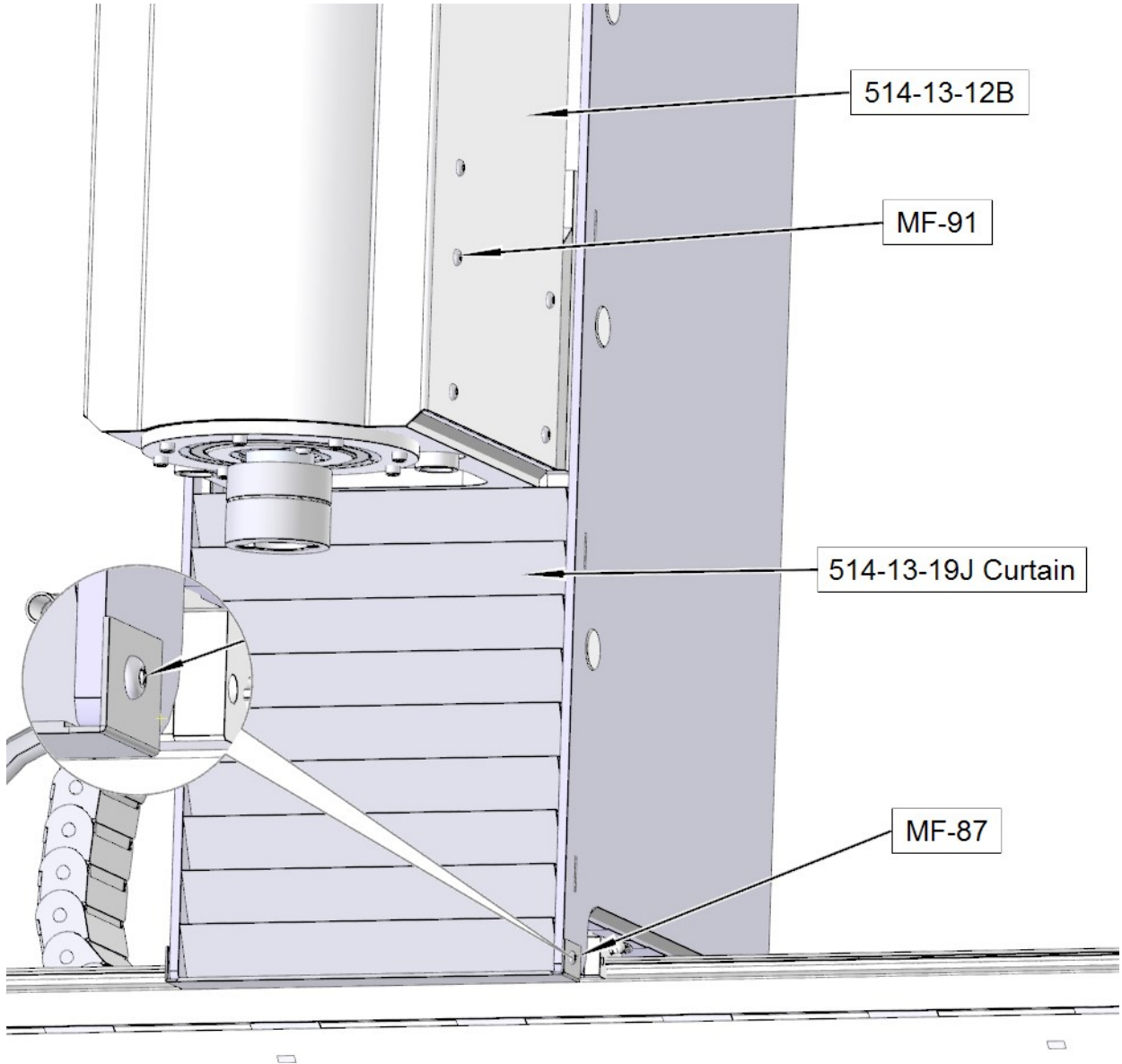

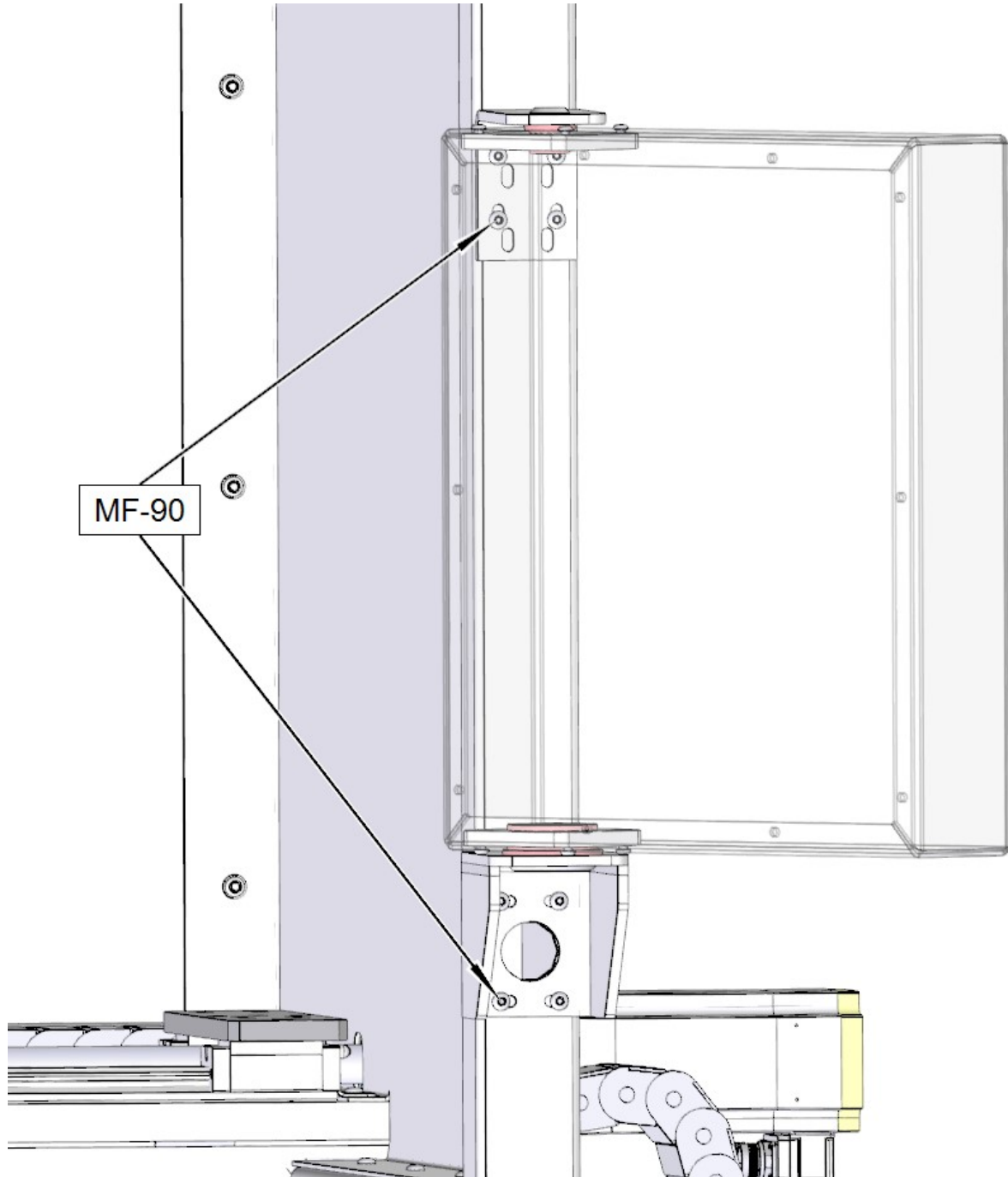

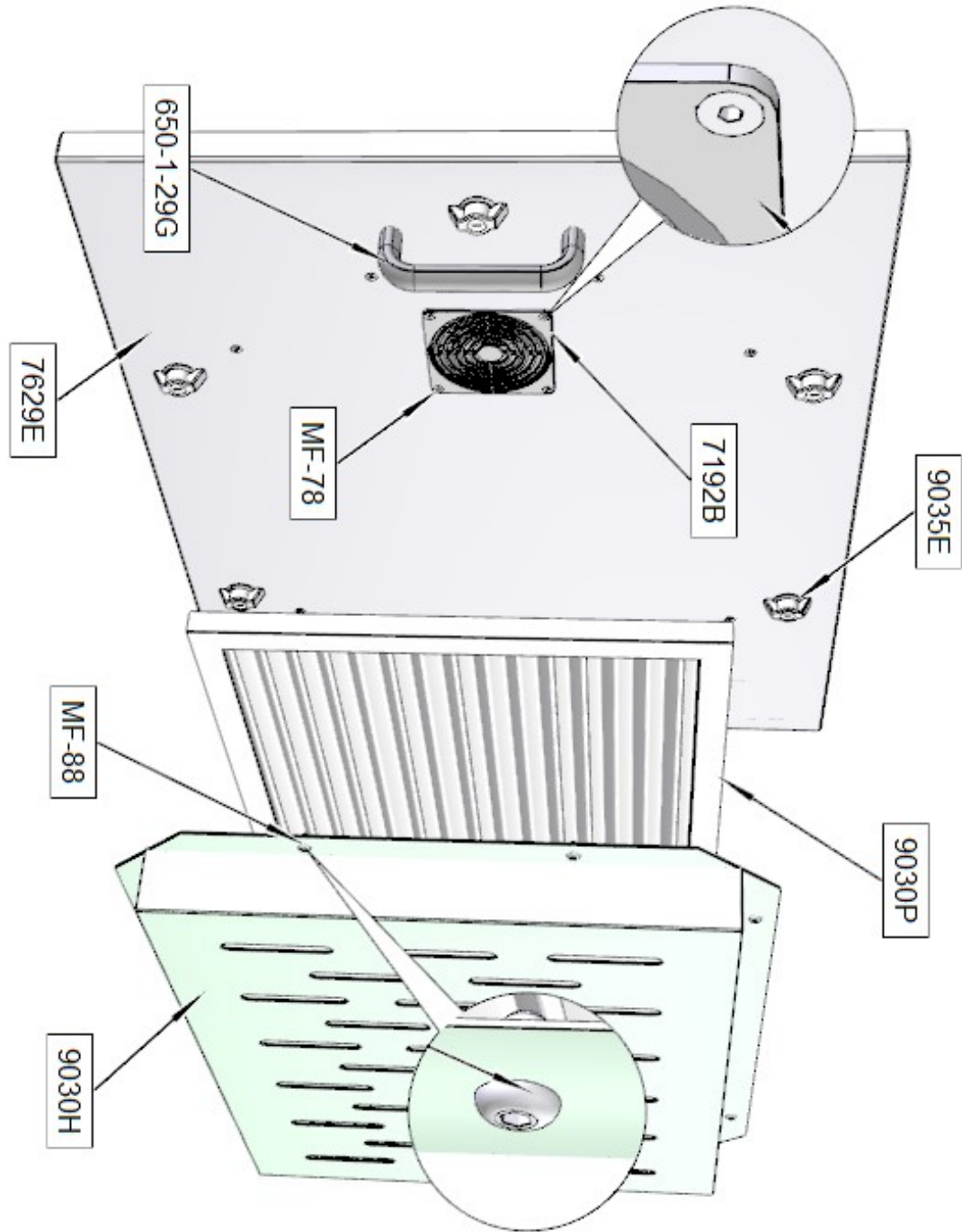

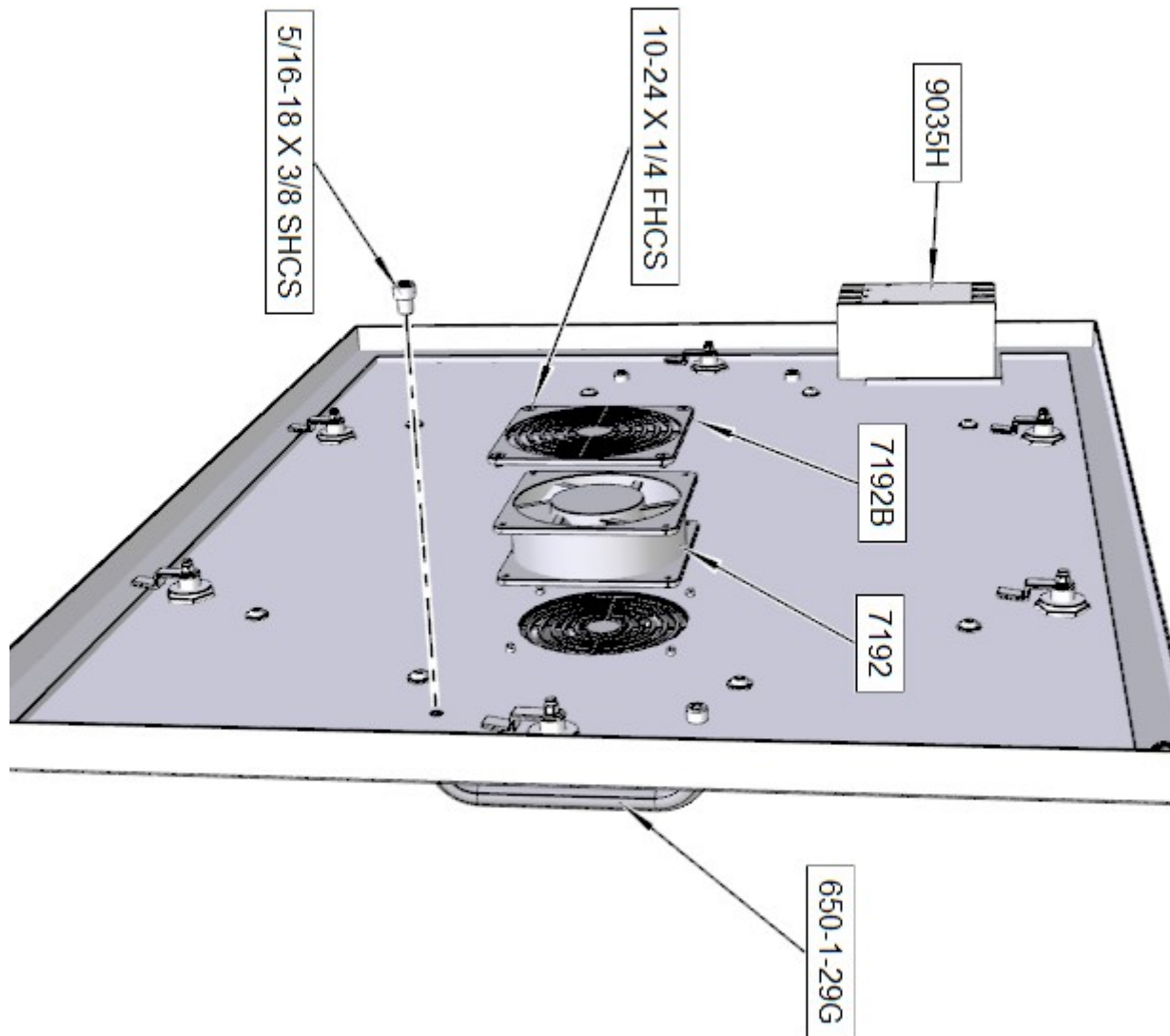

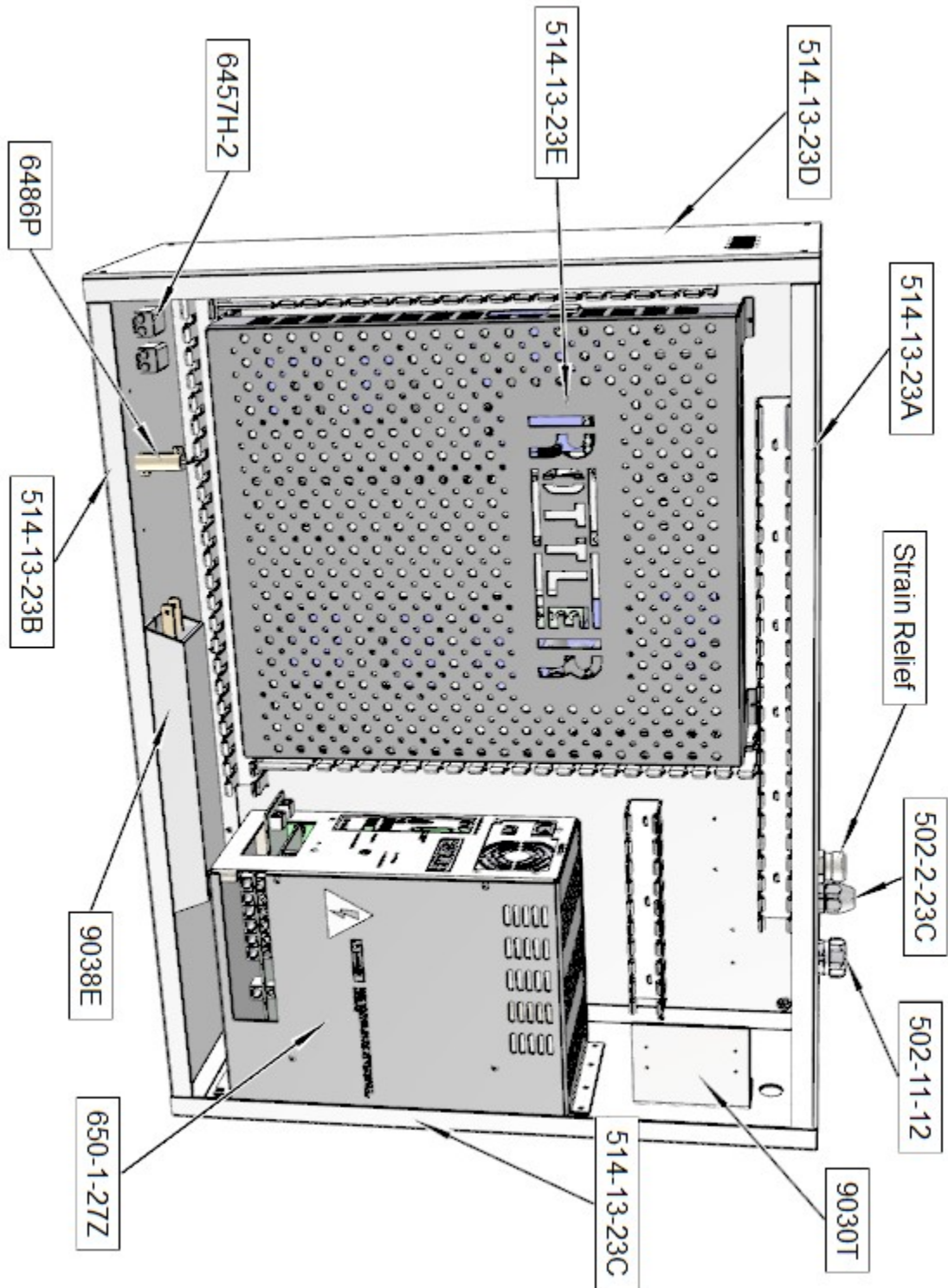

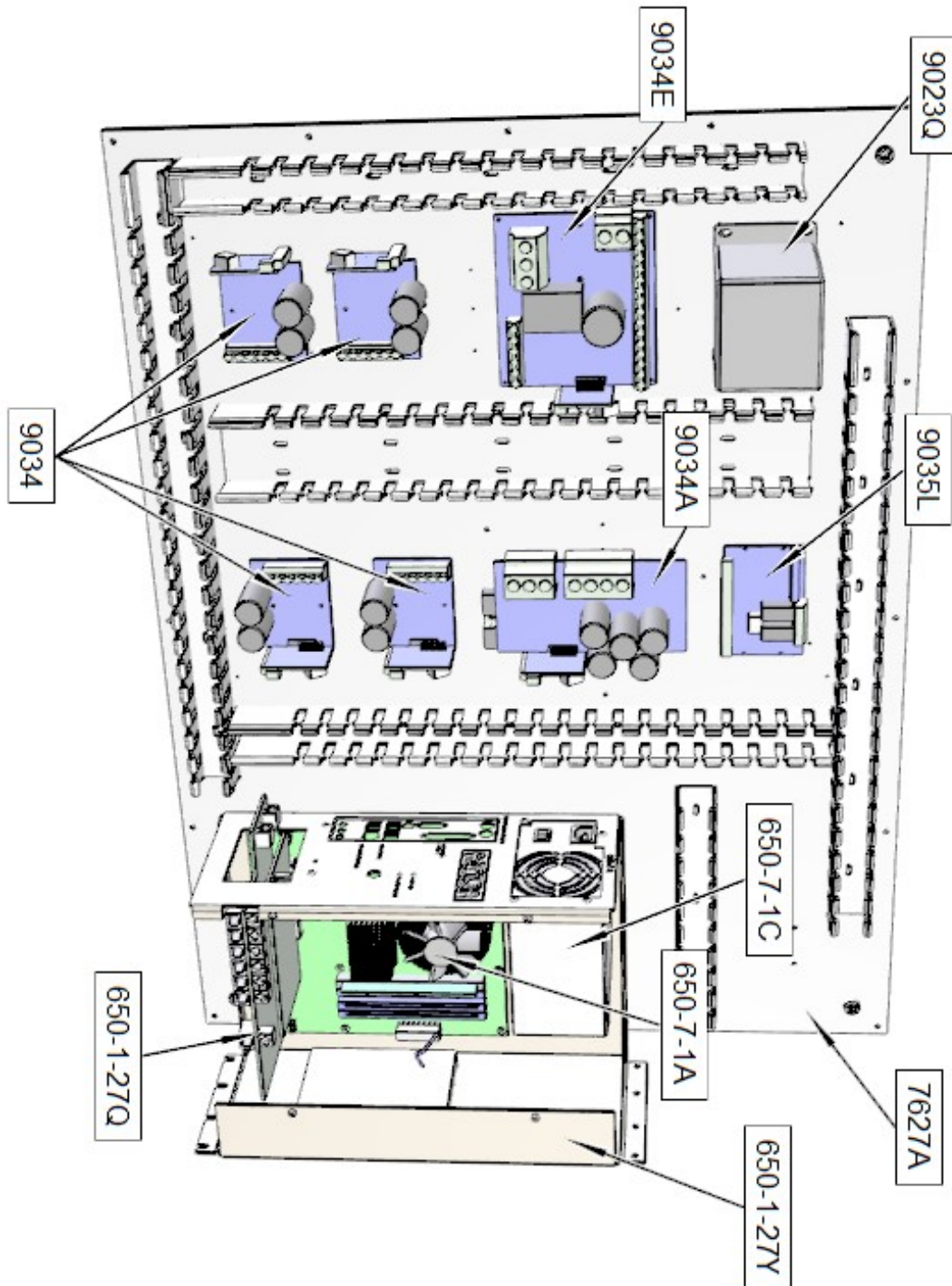

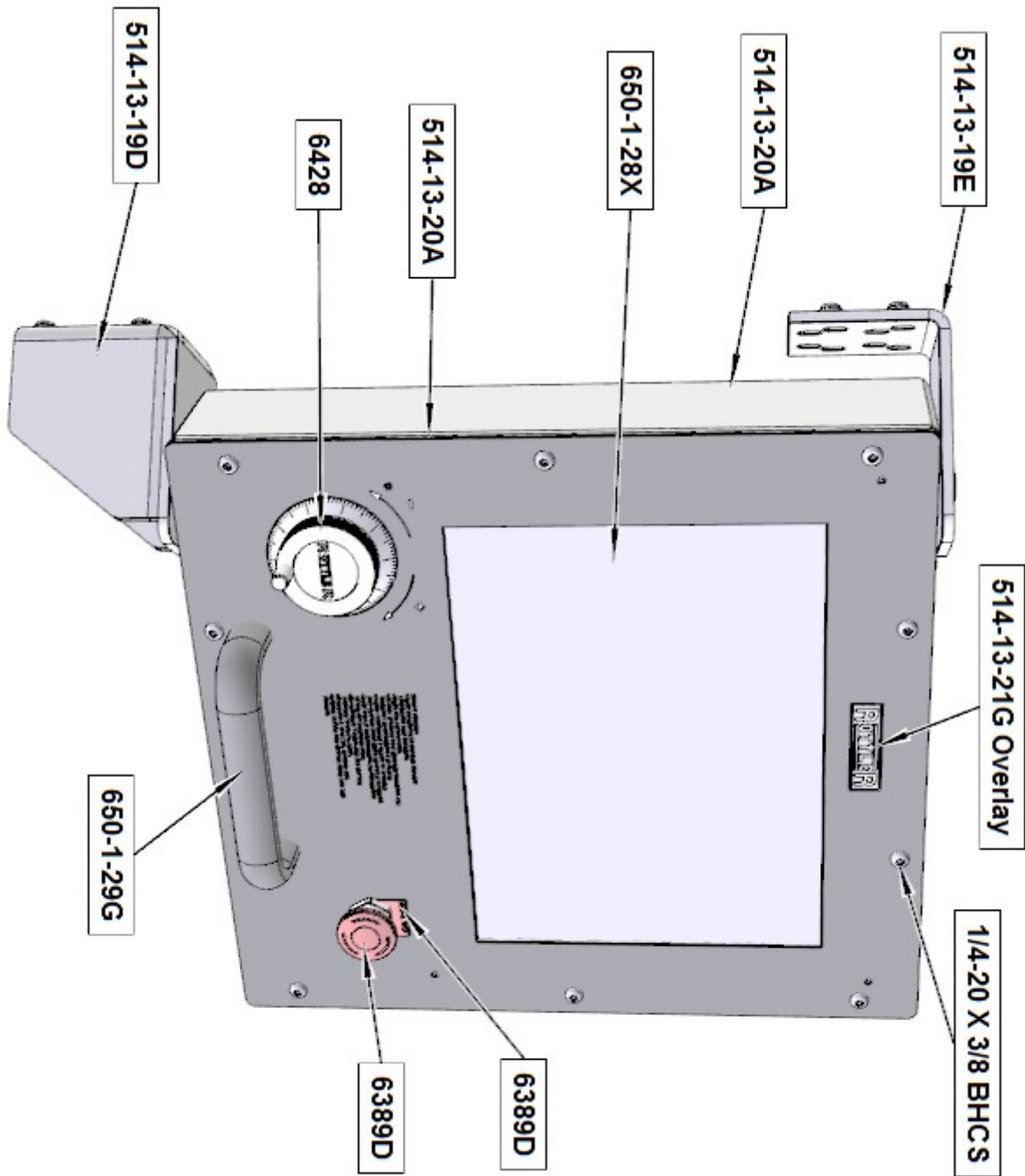

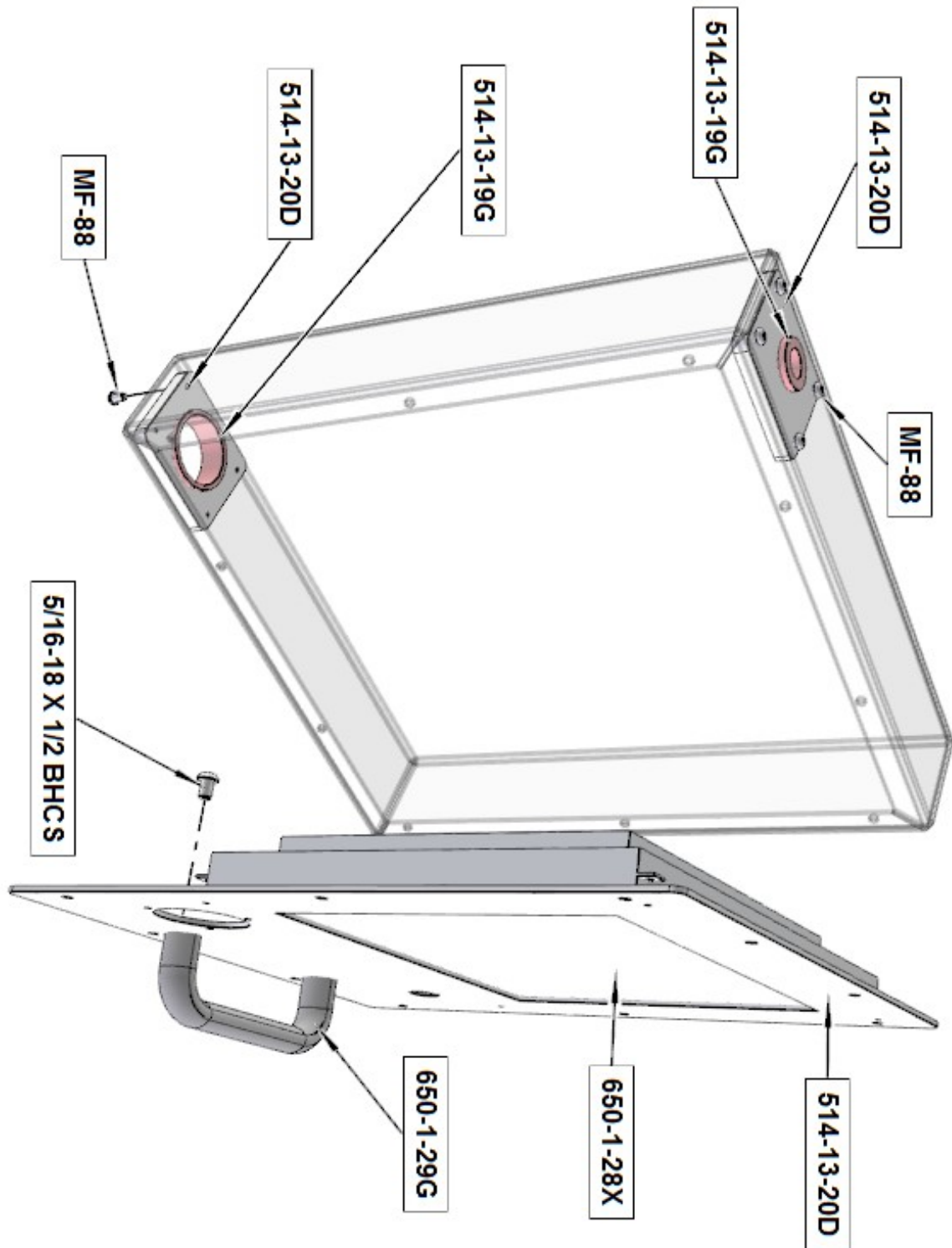

### Wiring Diagram

A scalable version of the wiring diagram is located on the manual CD.



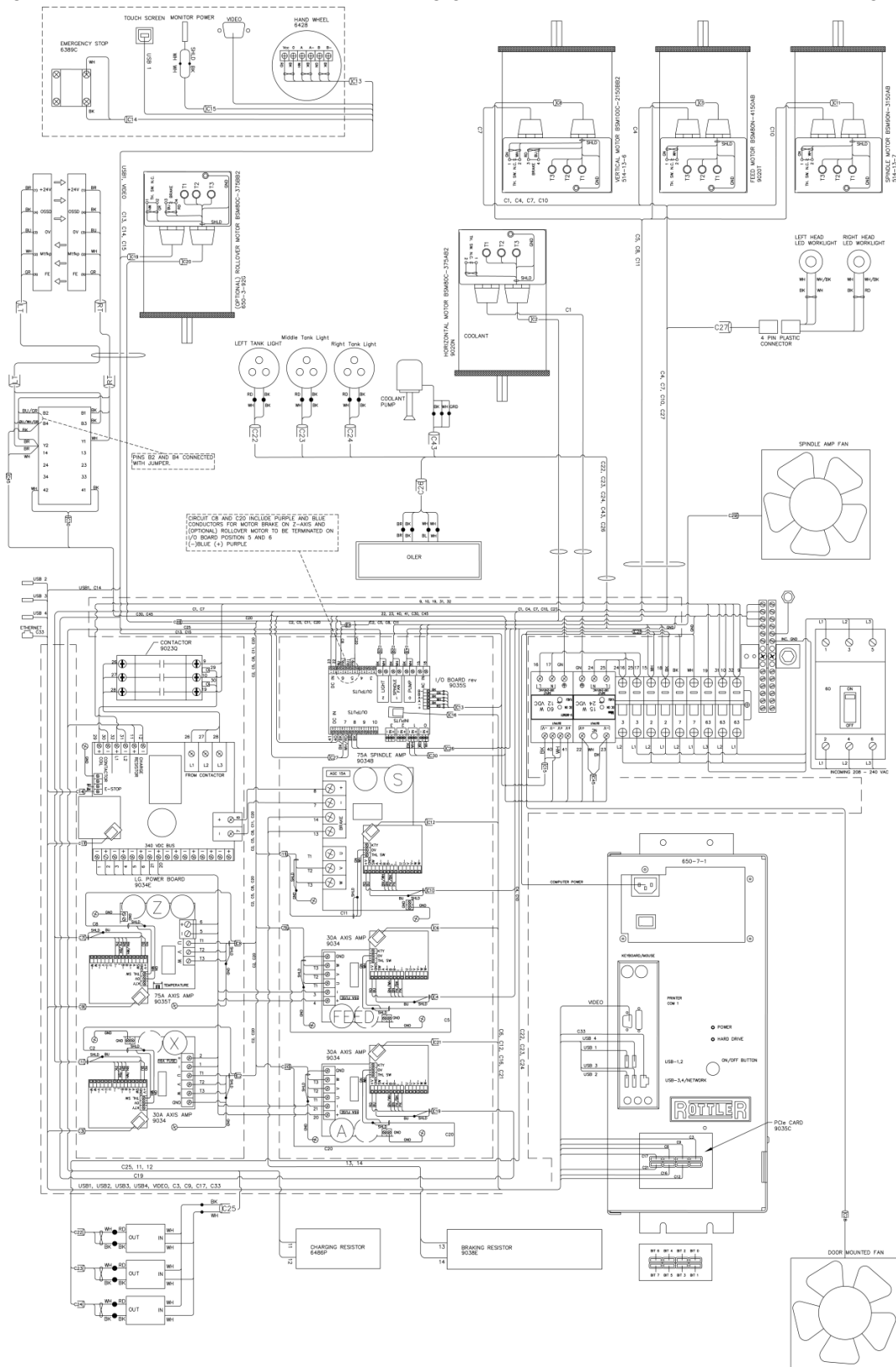

**This page intentionally left blank**

# OPTIONS

## Optional Equipment

Optional Equipment Catalog and Parts Manual are located on the Manual CD shipped with machine.



# MSDS

The Material Data Safety Sheets list shown in this section are the substances and materials that an operator is most likely to come in contact with while using this machine.

Other substances and materials are used in the manufacture, testing, and shipping of this machine. A complete list of the Material Data Safety Sheets of substances and materials used by Rottler Manufacturing during manufacturing, testing, and shipping is located on the Manual CD shipped with the machine. Material Data Safety Sheets are also located on the company web site: <http://www.rottlermfg.com/documentation.php>

**1) Rottler Honing Coolant**

**2) 76 Multi-Way Oil**

YUMATE SC-870C

**MATERIAL SAFETY DATA SHEET****SECTION I**

<b>PRODUCT NAME OR NUMBER (as it appears on label)</b> YUMATE SC-870C	<b>DATE</b> March, 2003
<b>MANUFACTURER'S NAME</b> YUMA INDUSTRIES INCORPORATED	<b>EMERGENCY PHONE #</b> YUMA 317-398-9862 CHEMTREC 800-424-9300
<b>ADDRESS (Number, Street, City, State, &amp; Zip Code)</b> 783 W. Mausoleum Road, Shelbyville, IN 46176 – 9720	
<b>HAZARDOUS MATERIAL DESCRIPTION, PROPER SHIPPING NAME, HAZ. CLASS, HAZ. ID #</b> None	
<b>ADDITIONAL HAZARD CLASSES (as applicable)</b> None	
<b>CHEMICAL FAMILY</b> Water Miscible Cutting & Grinding Fluid Concentrate	<b>FORMULA</b> See Section II

**SECTION II – INGREDIENTS**

CAS REGISTRY#	Wt. %	CHEMICAL NAME	Listed as a carcinogen in NTP, IARC, or OSHA 1910 (specify)
102-71-6	10-19	Triethanolamine ACGIH(TLV): TWA=5mg/m <sup>3</sup>	Not listed
141-43-5	1-9	Monoethanolamine ACGIH(TLV): TWA=3ppm, STEL=6mg/m <sup>3</sup> OSHA PEL : TWA=3ppm, STEL=6mg/m <sup>3</sup>	Not listed
Balance classified as non-hazardous Ingredients			

**SECTION III – PHYSICAL DATA**

<b>BOILING POINT</b> Not available	<b>SPECIFIC GRAVITY</b> (H <sub>2</sub> O=1) @20°C 1.07	<b>ODOR THRESHOLD (ppm)</b> Not available
<b>VAPOR PRESSURE</b> Not available	<b>PERCENT VOLATILE ( Vol.%)</b> Not available	<b>PERCENT SOLID (Wt.%)</b> Not available
<b>VAPOR DENSITY</b> Not available	<b>EVAPORATION RATE</b> Not available	<b>FREEZING POINT (°C)</b> Not available
<b>SOLUBILITY IN WATER</b> 100%	<b>pH</b> (10% solution) 8.5	<b>MATERIAL IS</b> Liquid
<b>APPEARANCE &amp; ODOR</b> Fluorescent with mild odor	<b>VOLATILE ORGANIC COMPOUNDS (VOC)</b> Not available	

**SECTION IV – FIRE AND EXPLOSION HAZARD DATA**

<b>FLASH POINT</b> none	<b>METHOD USED</b> LEL/UEL	<b>FLAMMABLE LIMITS</b> Not available	<b>AUTO-IGNITION TEMPERATURE (°C)</b> Not available
----------------------------	-------------------------------	--	--

YUMATE SC-870C

<b>EXTINGUISHING MEDIA</b> As appropriate for surrounding fire
<b>SPECIAL FIRE FIGHTING PROCEDURES</b> None
<b>UNUSUAL FIRE AND EXPLOSION HAZARDS</b> None

1

**SECTION V – HEALTH HAZARD DATA**

<b>THRESHOLD LIMIT VALUE</b> See Section II
<b>EFFECTS OF OVEREXPOSURE – Conditions to avoid</b> Transient eye irritation. Possible skin defatting and subsequent irritation on repeated or prolonged contact.
<b>PRIMARY ROUTES</b> <b>Inhalation:</b> <b>Eye Contact: OF</b> <b>ENTRY</b> <b>Skin Contact: X</b> <b>Ingestion:</b>
<b>EMERGENCY AND FIRST AID PROCEDURES</b>  <b>EYES:</b> Flush with cool, clean water for at least 15 minutes.  <b>SKIN:</b> Wash with soap and warm water.  <b>INHALATION:</b> Remove to fresh air.  <b>INGESTION:</b> If large quantities are ingested, pump stomach.  In every case get medical attention as required.

**SECTION VI – REACTIVITY DATA**

<b>STABILITY: UNSTABLE :</b> <b>HAZARDOUS</b> <b>MAY OCCUR:</b> <b>STABLE : X</b> <b>POLYMERIZATION WILL NOT OCCUR: X</b>
<b>CONDITIONS TO AVOID</b> None
<b>INCOMPATIBILITY (MATERIALS TO AVOID)</b> Avoid strong oxidizing agents, strong acids and nitrites.
<b>HAZARDOUS DECOMPOSITION PRODUCTS</b> Thermal decomposition may produce CO, CO <sub>2</sub> , NO <sub>x</sub> and SO <sub>x</sub> .

YUMATE SC-870C

**SECTION VII – SPILL OR LEAK PROCEDURES**

<b>STEPS TO BE TAKEN IN CASE MATERIAL IS RELEASED OR SPILLED</b> Mop up or use dry absorbent.
<b>WASTE DISPOSAL METHOD</b> Acid – Alum split Dispose in accordance with local, state and federal regulations.

2

**SECTION VIII – SPECIAL PROTECTION INFORMATION**

<b>RESPIRATORY PROTECTION (Specify type)</b> None	
<b>VENTILATION</b> <b>Local exhaust (Specify rate):</b> Not normally required. <b>Special:</b> None <b>Mechanical (general) (Specify rate):</b> General room ventilation should be sufficient. <b>Other:</b> None	
<b>PROTECTIVE GLOVES (Specify type)</b> None	<b>EYE PROTECTION (Specify type)</b> Safety glasses
<b>OTHER PROTECTIVE EQUIPMENT</b> None	

**SECTION IX – SPECIAL PRECAUTIONS**

<b>PRECAUTIONS TO BE TAKEN IN HANDLING AND STORING</b> Keep container closed. Wash thoroughly after handling.
<b>OTHER PRECAUTIONS</b> None



YUMATE SC-870C

3

# Safety Data Sheet



## Section 1: Identification of the substance or mixture and of the supplier

<b>Product Name:</b>	<b>Multi-Way Oil HD</b>
<b>SDS Number:</b>	817776
<b>Synonyms/Other Means of Identification:</b>	Multi-Way HD 32 Multi-Way HD 68 Multi-Way HD 220
<b>Intended Use:</b>	Way Oil
<b>Manufacturer:</b>	Phillips 66 Lubricants 600 N. Dairy Ashford, 2WL9072F Houston, Texas 77079-1175
<b>Emergency Health and Safety Number:</b>	Chemtrec: 800-424-9300 (24 Hours)
<b>Customer Service:</b>	U.S.: 1-800-822-6457 or International: +1-83-2486-3363
<b>Technical Information:</b>	1-877-445-9198
<b>SDS Information:</b>	Phone: 800-762-0942 Email: SDS@P66.com URL: www.Phillips66.com

## Section 2: Hazard(s) Identification

This material is not considered hazardous according to OSHA criteria.



## Section 3: Composition / Information on Ingredients

Component	CASRN	Concentration <sup>1</sup>
Lubricant Base Oil (Petroleum)	VARIOUS	>95
Additives	Proprietary	<5

<sup>1</sup>All concentrations are percent by weight unless ingredient is a gas. Gas concentrations are in percent by volume.

## Section 4: First Aid Measures

**Eye Contact:** If irritation or redness develops from exposure, flush eyes with clean water. If symptoms persist, seek medical attention.

**Skin Contact:** Remove contaminated shoes and clothing and cleanse affected area(s) thoroughly by washing with mild soap and water or a waterless hand cleaner. If irritation or redness develops and persists, seek medical attention.

**Inhalation (Breathing):** First aid is not normally required. If breathing difficulties develop, move victim away from source of exposure and into fresh air in a position comfortable for breathing. Seek immediate medical attention.

**Ingestion (Swallowing):** First aid is not normally required; however, if swallowed and symptoms develop, seek medical attention.

817776 - Multi-Way Oil HD  
Date of Issue: 14-Jun-2012

Page 1/7  
Status: FINAL

817776 - Multi-Way Oil HD  
Date of Issue: 14-Jun-2012

Page 2/7  
Status: FINAL

**Notes to Physician:** Acute aspirations of large amounts of oil-laden material may produce a serious aspiration pneumonia. Patients who aspirate these oils should be followed for the development of long-term sequelae. Inhalation exposure to oil mists below current workplace exposure limits is unlikely to cause pulmonary abnormalities.

**Medical Conditions Aggravated by Exposure:** Conditions which may be aggravated by exposure include skin disorders.

### Section 5: Fire-Fighting Measures

#### NFPA 704 Hazard Class

Health: 0 Flammability: 1 Instability: 0 (0-Minimal, 1-Slight, 2-Moderate, 3-Serious, 4-Severe)

**Unusual Fire & Explosion Hazards:** This material may burn, but will not ignite readily. If container is not properly cooled, it can rupture in the heat of a fire.

**Extinguishing Media:** Dry chemical, carbon dioxide, foam, or water spray is recommended. Water or foam may cause frothing of materials heated above 212°F / 100°C. Carbon dioxide can displace oxygen. Use caution when applying carbon dioxide in confined spaces. Simultaneous use of foam and water on the same surface is to be avoided as water destroys the foam.

**Fire Fighting Instructions:** For fires beyond the initial stage, emergency responders in the immediate hazard area should wear protective clothing. When the potential chemical hazard is unknown, in enclosed or confined spaces, a self contained breathing apparatus should be worn. In addition, wear other appropriate protective equipment as conditions warrant (see Section 8).

Isolate immediate hazard area and keep unauthorized personnel out. Stop spill/release if it can be done safely. Move undamaged containers from immediate hazard area if it can be done safely. Water spray may be useful in minimizing or dispersing vapors and to protect personnel. Cool equipment exposed to fire with water, if it can be done safely. Avoid spreading burning liquid with water used for cooling purposes.

**Hazardous Combustion Products:** Combustion may yield smoke, carbon monoxide, and other products of incomplete combustion. Oxides of sulfur, nitrogen or phosphorus may also be formed.

See Section 9 for Flammable Properties including Flash Point and Flammable (Explosive) Limits

### Section 6: Accidental Release Measures

**Personal Precautions:** This material may burn, but will not ignite readily. Keep all sources of ignition away from spill/release. Stay upwind and away from spill/release. Avoid direct contact with material. For large spillages, notify persons down wind of the spill/release, isolate immediate hazard area and keep unauthorized personnel out. Wear appropriate protective equipment, including respiratory protection, as conditions warrant (see Section 8). See Sections 2 and 7 for additional information on hazards and precautionary measures.

**Environmental Precautions:** Stop spill/release if it can be done safely. Prevent spilled material from entering sewers, storm drains, other unauthorized drainage systems, and natural waterways. Use water sparingly to minimize environmental contamination and reduce disposal requirements. If spill occurs on water notify appropriate authorities and advise shipping of any hazard. Spills into or upon navigable waters, the contiguous zone, or adjoining shorelines that cause a sheen or discoloration on the surface of the water, may require notification of the National Response Center (phone number 800-424-8802). If spill/release in excess of EPA reportable quantity (see Section 15) is made into the environment, immediately notify the National Response Center (phone number 800-424-8802).

**Methods for Containment and Clean-Up:** Notify relevant authorities in accordance with all applicable regulations. Immediate cleanup of any spill is recommended. Dike far ahead of spill for later recovery or disposal. Absorb spill with inert material such as sand or vermiculite, and place in suitable container for disposal. If spilled on water remove with appropriate methods (e.g. skimming, booms or absorbents). In case of soil contamination, remove contaminated soil for remediation or disposal, in accordance with local regulations.

Recommended measures are based on the most likely spillage scenarios for this material; however local conditions and regulations may influence or limit the choice of appropriate actions to be taken. See Section 13 for information on appropriate disposal.

### Section 7: Handling and Storage

**Precautions for safe handling:** Keep away from flames and hot surfaces. Wash thoroughly after handling. Use good personal hygiene practices and wear appropriate personal protective equipment (see section 8).

817776 - Multi-Way Oil HD  
Date of Issue: 14-Jun-2012

Page 3/7  
Status: FINAL

Spills will produce extremely slippery surfaces. Do not enter confined spaces such as tanks or pits without following proper entry procedures such as ASTM D-4276 and 29CFR 1910.146. Do not wear contaminated clothing or shoes.

**Conditions for safe storage:** Keep container(s) tightly closed and properly labeled. Use and store this material in cool, dry, well-ventilated area away from heat and all sources of ignition. Store only in approved containers. Keep away from any incompatible material (see Section 10). Protect container(s) against physical damage.

"Empty" containers retain residue and may be dangerous. Do not pressurize, cut, weld, braze, solder, drill, grind, or expose such containers to heat, flame, sparks, or other sources of ignition. They may explode and cause injury or death. "Empty" drums should be completely drained, properly bunged, and promptly shipped to the supplier or a drum reconditioner. All containers should be disposed of in an environmentally safe manner and in accordance with governmental regulations. Before working on or in tanks which contain or have contained this material, refer to OSHA regulations, ANSI Z49.1, and other references pertaining to cleaning, repairing, welding, or other contemplated operations.

### Section 8: Exposure Controls / Personal Protection

Component	ACGIH	OSHA	Other
Lubricant Base Oil (Petroleum)	TWA: 5mg/m <sup>3</sup> STEL: 10 mg/m <sup>3</sup> as oil mist, if generated	TWA: 5 mg/m <sup>3</sup> as Oil Mist, if generated	---

**Note:** State, local or other agencies or advisory groups may have established more stringent limits. Consult an industrial hygienist or similar professional, or your local agencies, for further information.

**Engineering controls:** If current ventilation practices are not adequate to maintain airborne concentrations below the established exposure limits, additional engineering controls may be required.

**Eye/Face Protection:** The use of eye/face protection is not normally required; however, good industrial hygiene practice suggests the use of eye protection that meets or exceeds ANSI Z.87.1 whenever working with chemicals.

**Skin/Hand Protection:** The use of skin protection is not normally required; however, good industrial hygiene practice suggests the use of gloves or other appropriate skin protection whenever working with chemicals. Suggested protective materials: Nitrile

**Respiratory Protection:** Where there is potential for airborne exposure above the exposure limit a NIOSH certified air purifying respirator equipped with R or P95 filters may be used.

A respiratory protection program that meets or is equivalent to OSHA 29 CFR 1910.134 and ANSI Z88.2 should be followed whenever workplace conditions warrant a respirator's use. Air purifying respirators provide limited protection and cannot be used in atmospheres that exceed the maximum use concentration (as directed by regulation or the manufacturer's instructions), in oxygen deficient (less than 19.5 percent oxygen) situations, or under conditions that are immediately dangerous to life and health (IDLH).

Suggestions provided in this section for exposure control and specific types of protective equipment are based on readily available information. Users should consult with the specific manufacturer to confirm the performance of their protective equipment. Specific situations may require consultation with industrial hygiene, safety, or engineering professionals.

### Section 9: Physical and Chemical Properties

**Note:** Unless otherwise stated, values are determined at 20°C (68°F) and 760 mm Hg (1 atm). Data represent typical values and are not intended to be specifications.

<b>Appearance:</b>	Dark amber
<b>Physical Form:</b>	Liquid
<b>Odor:</b>	Petroleum
<b>Odor Threshold:</b>	No data
<b>pH:</b>	Not applicable
<b>Vapor Pressure:</b>	<1 mm Hg
<b>Vapor Density (air=1):</b>	>1
<b>Initial Boiling Point/Range:</b>	No data
<b>Melting/Freezing Point:</b>	No data
<b>Pour Point:</b>	< 5 °F / < -15 °C
<b>Solubility in Water:</b>	Insoluble
<b>Partition Coefficient (n-octanol/water) (Kow):</b>	No data

817776 - Multi-Way Oil HD  
Date of Issue: 14-Jun-2012

Page 4/7  
Status: FINAL

Specific Gravity (water=1):	0.865 - 0.884 @ 60°F (15.6°C)
Bulk Density:	7.20 - 7.37 lbs/gal
Viscosity:	5 - 20 cSt @ 100°C; 32 - 220 cSt @ 40°C
Evaporation Rate (nBuAc=1):	No data
Flash Point:	> 320 °F / > 160 °C
Test Method:	Pensky-Martens Closed Cup (PMCC), ASTM D93, EPA 1010
Lower Explosive Limits (vol % in air):	No data
Upper Explosive Limits (vol % in air):	No data
Auto-ignition Temperature:	No data

### Section 10: Stability and Reactivity

**Stability:** Stable under normal ambient and anticipated conditions of use.

**Conditions to Avoid:** Extended exposure to high temperatures can cause decomposition. Avoid all possible sources of ignition.

**Materials to Avoid (Incompatible Materials):** Avoid contact with strong oxidizing agents and strong reducing agents.

**Hazardous Decomposition Products:** Not anticipated under normal conditions of use.

**Hazardous Polymerization:** Not known to occur.

### Section 11: Toxicological Information

#### Information on Toxicological Effects of Substance/Mixture

Acute Toxicity	Hazard	Additional Information	LC50/LD50 Data
Inhalation	Unlikely to be harmful		>5 mg/L (mist, estimated)
Skin Absorption	Unlikely to be harmful		> 2 g/kg (estimated)
Ingestion (Swallowing)	Unlikely to be harmful		> 5 g/kg (estimated)

**Aspiration Hazard:** Not expected to be an aspiration hazard.

**Skin Corrosion/Irritation:** Not expected to be irritating. Repeated exposure may cause skin dryness or cracking.

**Serious Eye Damage/Irritation:** Not expected to be irritating.

**Signs and Symptoms:** Inhalation of oil mists or vapors generated at elevated temperatures may cause respiratory irritation. Accidental ingestion can result in minor irritation of the digestive tract, nausea and diarrhea.

**Skin Sensitization:** Not expected to be a skin sensitizer.

**Respiratory Sensitization:** No information available.

**Specific Target Organ Toxicity (Single Exposure):** No information available on the mixture, however none of the components have been classified for target organ toxicity (or are below the concentration threshold for classification).

**Specific Target Organ Toxicity (Repeated Exposure):** No information available on the mixture, however none of the components have been classified for target organ toxicity (or are below the concentration threshold for classification).

**Carcinogenicity:** No information available on the mixture, however none of the components have been classified for carcinogenicity (or are below the concentration threshold for classification). A mortality study sponsored by General Motors and the United Auto Workers suggested a link between cutting oils or machining fluids and various forms of cancer (e.g., esophageal, laryngeal, and rectal). The study evaluated workplace exposures from 1940-1984. Since the composition of these materials has changed substantially since 1940, and because the most notable effects were seen among those with work histories dating back to that time, the relevance of these findings to present-day exposures is uncertain. Cutting oils or machining fluids have not been identified as carcinogens by NTP, IARC, or OSHA.

**Germ Cell Mutagenicity:** No information available on the mixture, however none of the components have been classified for germ cell mutagenicity (or are below the concentration threshold for classification).

817776 - Multi-Way Oil HD  
Date of Issue: 14-Jun-2012

Page 5/7  
Status: FINAL

**Reproductive Toxicity:** No information available on the mixture, however none of the components have been classified for reproductive toxicity (or are below the concentration threshold for classification).

#### Information on Toxicological Effects of Components

##### Lubricant Base Oil (Petroleum)

**Carcinogenicity:** The petroleum base oils contained in this product have been highly refined by a variety of processes including severe hydrocracking/hydroprocessing to reduce aromatics and improve performance characteristics. All of the oils meet the IP-346 criteria of less than 3 percent PAH's and are not considered carcinogens by NTP, IARC, or OSHA.

### Section 12: Ecological Information

**Toxicity:** All acute aquatic toxicity studies on samples of lubricant base oils show acute toxicity values greater than 100 mg/L for invertebrates, algae and fish. These tests were carried out on water accommodated fractions and the results are consistent with the predicted aquatic toxicity of these substances based on their hydrocarbon compositions. Classification: No classified hazards.

**Persistence and Degradability:** The hydrocarbons in this material are not readily biodegradable, but since they can be degraded by microorganisms, they are regarded as inherently biodegradable.

**Bioaccumulative Potential:** Log Kow values measured for the hydrocarbon components of this material are greater than 5.3, and therefore regarded as having the potential to bioaccumulate. In practice, metabolic processes may reduce bioconcentration.

**Mobility in Soil:** Volatilization to air is not expected to be a significant fate process due to the low vapor pressure of this material. In water, base oils will float and spread over the surface at a rate dependent upon viscosity. There will be significant removal of hydrocarbons from the water by sediment adsorption. In soil and sediment, hydrocarbon components will show low mobility with adsorption to sediments being the predominant physical process. The main fate process is expected to be slow biodegradation of the hydrocarbon constituents in soil and sediment.

**Other Adverse Effects:** None anticipated.

### Section 13: Disposal Considerations

The generator of a waste is always responsible for making proper hazardous waste determinations and needs to consider state and local requirements in addition to federal regulations.

This material, if discarded as produced, would not be a federally regulated RCRA "listed" hazardous waste and is not believed to exhibit characteristics of hazardous waste. See Sections 7 and 8 for information on handling, storage and personal protection and Section 9 for physical/chemical properties. It is possible that the material as produced contains constituents which are not required to be listed in the MSDS but could affect the hazardous waste determination. Additionally, use which results in chemical or physical change of this material could subject it to regulation as a hazardous waste.

This material under most intended uses would become "Used Oil" due to contamination by physical or chemical impurities. Whenever possible, Recycle used oil in accordance with applicable federal and state or local regulations. Container contents should be completely used and containers should be emptied prior to discard.

### Section 14: Transport Information

#### U.S. Department of Transportation (DOT)

Shipping Description: *Not regulated*  
Note: *If shipped by land in a packaging having a capacity of 3,500 gallons or more, the provisions of 49 CFR, Part 130 apply. (Contains oil)*

#### International Maritime Dangerous Goods (IMDG)

Shipping Description: *Not regulated*  
Note: *U.S. DOT compliance requirements may apply. See 49 CFR 171.22, 23 & 25.*

#### International Civil Aviation Org. / International Air Transport Assoc. (ICAO/IATA)

UN/ID #: *Not regulated*  
Note: *U.S. DOT compliance requirements may apply. See 49 CFR 171.22, 23 & 24.*

	LTD. QTY	Passenger Aircraft	Cargo Aircraft Only
Packaging Instruction #:	---	---	---
Max. Net Qty. Per Package:	---	---	---

817776 - Multi-Way Oil HD  
Date of Issue: 14-Jun-2012

Page 6/7  
Status: FINAL

### Section 15: Regulatory Information

#### CERCLA/SARA - Section 302 Extremely Hazardous Substances and TPQs (in pounds):

This material does not contain any chemicals subject to the reporting requirements of SARA 302 and 40 CFR 372.

#### CERCLA/SARA - Section 311/312 (Title III Hazard Categories)

Acute Health:	No
Chronic Health:	No
Fire Hazard:	No
Pressure Hazard:	No
Reactive Hazard:	No

#### CERCLA/SARA - Section 313 and 40 CFR 372:

This material does not contain any chemicals subject to the reporting requirements of SARA 313 and 40 CFR 372.

#### EPA (CERCLA) Reportable Quantity (in pounds):

This material does not contain any chemicals with CERCLA Reportable Quantities. This material contains the following chemicals subject to the reporting requirements of 40 CFR 302.4:

#### California Proposition 65:

This material does not contain any chemicals which are known to the State of California to cause cancer, birth defects or other reproductive harm at concentrations that trigger the warning requirements of California Proposition 65.

#### International Hazard Classification

**GHS Classification**  
None

**Canada:**  
This product has been classified in accordance with the hazard criteria of the Controlled Products Regulations (CPR) and the MSDS contains all the information required by the Regulations.

**WHMIS Hazard Class:**  
None

#### National Chemical Inventories

All components are either listed on the US TSCA Inventory, or are not regulated under TSCA  
All components are either on the DSL, or are exempt from DSL listing requirements

U.S. Export Control Classification Number: EAR99

### Section 16: Other Information

Date of Issue:	14-Jun-2012
Status:	FINAL
Previous Issue Date:	04-Aug-2011
Revised Sections or Basis for Revision:	Format change Manufacturer (Section 1) Toxicological (Section 11) Regulatory information (Section 15)
SDS Number:	817776

#### Guide to Abbreviations:

ACGIH = American Conference of Governmental Industrial Hygienists; CASRN = Chemical Abstracts Service Registry Number; CEILING = Ceiling Limit (15 minutes); CERCLA = The Comprehensive Environmental Response, Compensation, and Liability Act; EPA = Environmental Protection Agency; GHS = Globally Harmonized System; IARC = International Agency for Research on Cancer; INSHT = National Institute for Health and Safety at Work; IOPC = International Oil Pollution Compensation; LEL = Lower Explosive Limit; NE = Not Established; NFPA = National Fire Protection Association; NTP = National Toxicology Program; OSHA = Occupational Safety and Health Administration; PEL = Permissible Exposure Limit (OSHA); SARA = Superfund Amendments and Reauthorization Act; STEL = Short Term Exposure Limit (15 minutes); TLV = Threshold Limit Value (ACGIH); TWA = Time Weighted Average (8 hours); UEL = Upper Explosive Limit; WHMIS = Worker Hazardous Materials Information System (Canada)

817776 - Multi-Way Oil HD  
Date of Issue: 14-Jun-2012

Page 717  
Status: FINAL

---

**Disclaimer of Expressed and implied Warranties:**

The information presented in this Material Safety Data Sheet is based on data believed to be accurate as of the date this Material Safety Data Sheet was prepared. HOWEVER, NO WARRANTY OF MERCHANTABILITY, FITNESS FOR ANY PARTICULAR PURPOSE, OR ANY OTHER WARRANTY IS EXPRESSED OR IS TO BE IMPLIED REGARDING THE ACCURACY OR COMPLETENESS OF THE INFORMATION PROVIDED ABOVE, THE RESULTS TO BE OBTAINED FROM THE USE OF THIS INFORMATION OR THE PRODUCT, THE SAFETY OF THIS PRODUCT, OR THE HAZARDS RELATED TO ITS USE. No responsibility is assumed for any damage or injury resulting from abnormal use or from any failure to adhere to recommended practices. The information provided above, and the product, are furnished on the condition that the person receiving them shall make their own determination as to the suitability of the product for their particular purpose and on the condition that they assume the risk of their use. In addition, no authorization is given nor implied to practice any patented invention without a license.