

ROTTLER

THE CUTTING EDGE

SG100XY

Large Capacity Cylinder Head Seat & Guide Machine

With ACTIV Spindle & Guide-to-Guide Automation



your machining time,
productivity and profits!



Machining Equipment
Created for Performance
Racing & Engine
Machining.

So Advanced, It's Simple.

SG100XY CYLINDER HEAD SEAT & GUIDE MACHINE

There are two common designs for diesel cylinder heads: large (huge) castings for 6 cylinder inline engines with 24 valves, and single-cylinder heads, each with 4 valves (such as found on the CAT 3500).

The single cylinder heads are the biggest challenge! Most seat and guide machines can only handle one single head at a time, requiring the operator to load, clamp, machine intake seats, change tooling, machine exhaust seats and then unload the completed head before loading the next head. A tremendous amount of time is wasted! Operator fatigue becomes a real concern as the operator has to spend so much time just loading and unloading and not getting the critical machine work done of cutting valve seats and honing valve guides! Rottler has developed fixtures that allow easy loading of four single heads and then, with one button operation, all heads are clamped at once. The fixture is designed to accommodate different height heads as often heads being remanufactured have been worked on before and are not equal thickness and also may not be parallel. After the heads are clamped, the SG100XY is able to machine all the intake seats unattended and after a quick tool change, the software automatically changes the program to cut all the exhaust seats unattended.

For the large 24 valve castings, Rottler has developed a servo-controlled 360-degree rollover fixture with power clamping. Easy and fast to set up, these huge castings can be rotated 360 degrees and leveled for many operations such as valve guide and spring seat repairs, injector tube repairs and even drilling out broken studs on the exhaust manifold surface on the side of the heads.

ACTIV SPINDLE

The Centerline of all valve guides in one cylinder head are not always in perfect alignment. The SG100XY has the latest design **ACTIV** Spindle which has a sphere built inside the spindle which compensates for any misalignment and allows the **UNIPILOT** tooling system to automatically center with reference to the valve guide centerline while the workhead is floating on air cushions. Once the floating stops and the workhead clamps, the **UNIPILOT** and valve guide centerline are maintained while the valve seat is cut giving excellent **CONCEN**. When doing machining operations other than valve seat cutting such as valve seat housing counterboring and valve guide reaming, the spindle is required to be locked vertically. The **ACTIV** spindle has a pneumatic locking system that locks the spindle sphere rigidly vertically for other types of machining requirements.

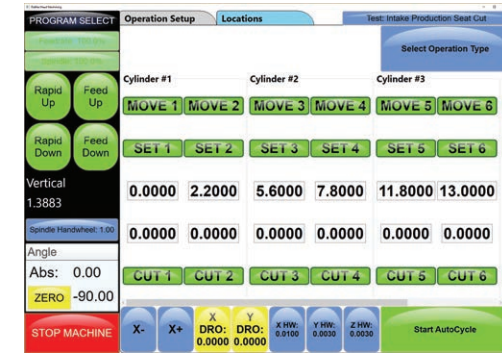
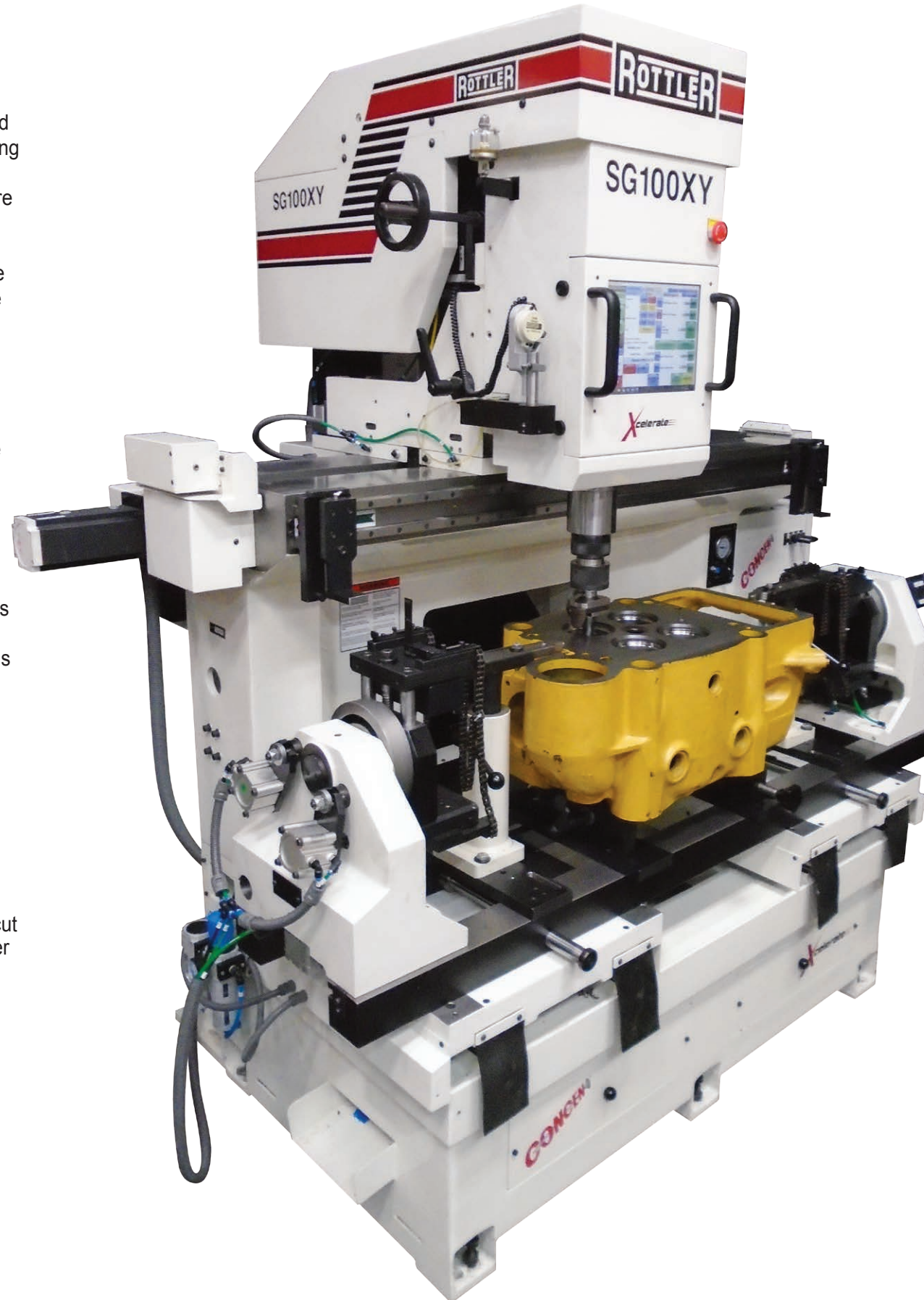

Windows Touch Screen Control

Windows based touch screen control is easy to use for automatic hole to hole operation without requiring complex CNC programming.

Light Weight Workhead floats on Base Plate

The new design SG series utilizes a very light workhead that floats independently on a base plate allowing precise centering of the pilot in the valve guide. The base plate moves the workhead from guide-to-guide by a precision ball screw and servo motor. The complete assembly clamps with air pressure for rigid machining.

Quick X Axis Alignment System (Patent Pending)

This feature is the secret to productive guide-to-guide automatic machining! After the cylinder head is clamped in the fixture, 2 pilots are installed in the outer valve guides and 2 of the alignment arms are moved on linear slideways inline with the 2 pilots. At this stage, the complete fixture assembly floats on air and the 2 pilots contact the 2 alignment arms which aligns the valve guides with the X axis movement of the workhead. At this stage, the fixture clamps on the machine table, the 2 pilots are removed and the cylinder head is ready for automatic guide-to-guide machining.

SSV - Spindle Speed Variation

Rottler has developed special spindle motor control technology to vary the spindle speed while finish cutting the valve seat. SSV varies the spindle speed to specified speeds and controls the time of acceleration and deceleration in micro seconds giving improved surface finish for perfect CONCEN and vacuum seal.



WINDOWS TOUCH SCREEN CONTROL

Rottler New Technology Touch Screen CNC control uses 'state of the art' Direct Motion Control Technology and Windows Operating System. The PC computer links directly to the internet for future software upgrades and servicing worldwide. Rottler technicians are able to connect direct to the machine computer.

Conversational Touch Screen Control allows simple programming for many cylinder head machining operations such as Seat Cutting, Housing Boring, Guide Reaming, Drilling, Tapping, and many more functions. No experience required and easy to operate with information saved for future use. Store additional information in the SG100XY computer such as specification manuals, machining data, etc.

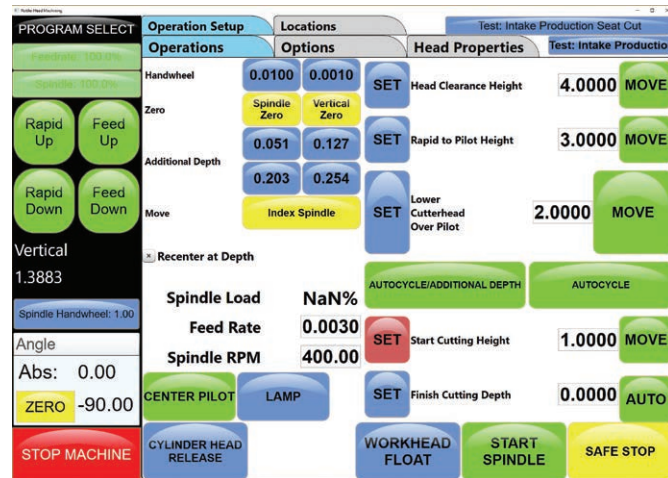

Main Control Screen allows settings for vertical movement of spindle, speed and feed of cutting, and various buttons for setting up a new program.

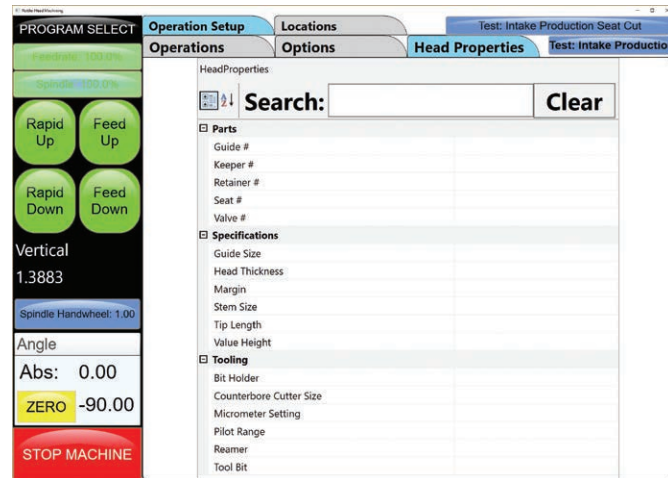

Information and Specifications can be saved together with the programs for each cylinder head. All programs can be backed up for security.



Multiple Cylinders/Valve Guides are programmed so that the SG100XY can move automatically from guide-to-guide – unattended. The slider allows 24 valve guide centers to be programmed in X and Y location.

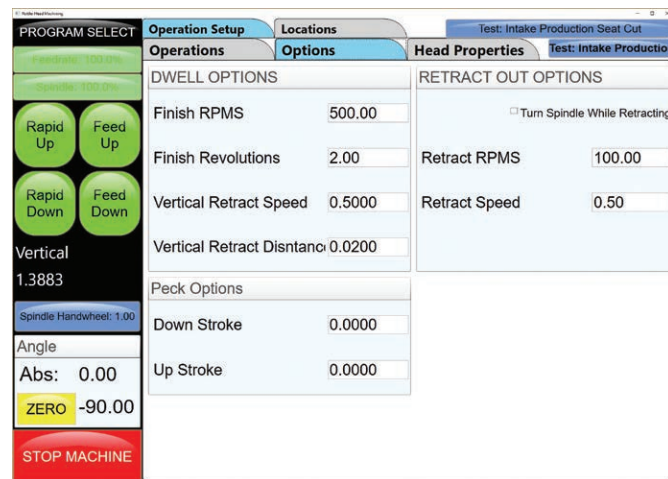

Dwell and Retract are the important settings that allow precision valve seat machining for features such as surface finish and CONCEN.

CYLINDER HEAD TECHNOLOGY

According to industry research, cylinder head work remains the single biggest part of the typical gas and diesel engine rebuilding business. With today's engines, the terms "close enough" and "almost" are unacceptable. Yesterday's equipment offers neither the speed nor accuracy required. Outdated equipment is slow to setup and needs more operator skill. Valuable man-hours that could be better spent on other tasks are often wasted doing things the old-fashioned way.

Thanks to our pioneering use of electronic controls and state-of-the-art cutting tools and fixturing, Rottler has overcome many of the traditional bottlenecks that slow work flow through a shop. Operation and programming of Rottler machines is done using ergonomic touch screen positioned on the front of the machine. The display tells the operator exactly where the spindle is positioned at all times.

ACTIV Spindle

The SG100XY has the latest design **ACTIV** Spindle Technology. The Rottler **ACTIV** spindle is mounted on a sphere, which allows the **UNIPILOT** tooling system to automatically center with the valve guide centerline while the workhead is floating on air cushions. Once air floating stops and the workhead clamps, the **UNIPILOT** and valve guide centerline are maintained while cutting the valve seat.

The **ACTIV** spindle can be used just like a fixed spindle – sphere is locked by air pressure vertically so jobs like reaming, drilling, tapping, etc., can be accurately done on the **ACTIV** spindle machines.



Unipilot
The Speed of Live and the Accuracy of Fixed

CONCEN

Rottler **UNIPILOT** patented tooling loads securely into the Rottler Automatic Quick Clamping System holding the tooling in the spindle without the need for wrenches.

The **UNIPILOT** Tooling system allows the carbide centralizing **UNIPILOT** to work like a live pilot. **UNIPILOT** Tooling stays in the spindle while moving from valve guide to valve guide. Rottler **UNIPILOT** Tooling has a fixed pilot design to improve **CONCEN** eliminating clearance found in live pilots.

The lower taper on the spring loaded **UNIPILOT** easily enters the valve guide. The spring loaded upper area fixes and centers in the valve guide automatically eliminating clearance between the pilot and guide.

After cutting the valve seat, the **UNIPILOT** rises with the spindle ready to float over the head gasket fire decks in position to enter the next valve guide.

The **CONCEN** trademark is Rottler's promise of quality. **CONCEN** creates the most accurate and versatile seat and guide machines on the market today. The centering action of Rottler's Precision Carbide **UNIPILOT** System, supported on our balanced air float work head, give perfect centering in the valve guide. The Rottler combination creates the best **CONCEN** of valve seat to valve guide in the industry.

UNIVERSAL POWER ROLL OVER FIXTURE

360 Degree Rotation of Large Cylinder Heads

Many cylinder head rebuilders asked us that they need to rotate cylinder heads 360 degrees to be able to do machine work on all sides of the cylinder head such as injector tube or spark plug work, and odd jobs such as drilling and tapping broken studs on exhaust flange surfaces. Rottler's 360 degree roll fixture is the answer, allowing large 24 valve cylinder heads to be clamped with reference to their head gasket fire deck and rolled 360 degrees in one set up. The heavy duty clamping and fine adjust system allow quick leveling and rigid clamping for heavy cutting during machining.

Equal Valve Seat Depth

Smooth and reliable running engines require balanced combustion chambers and equal valve seat depth is the most important specifications to achieve balanced combustion chamber volume. The most important feature of these fixtures is the cylinder heads are located so that the head gasket fire deck is parallel to the machine slideways which allows each valve seat to be machined to the same depth as the machine moves automatically from seat to seat.

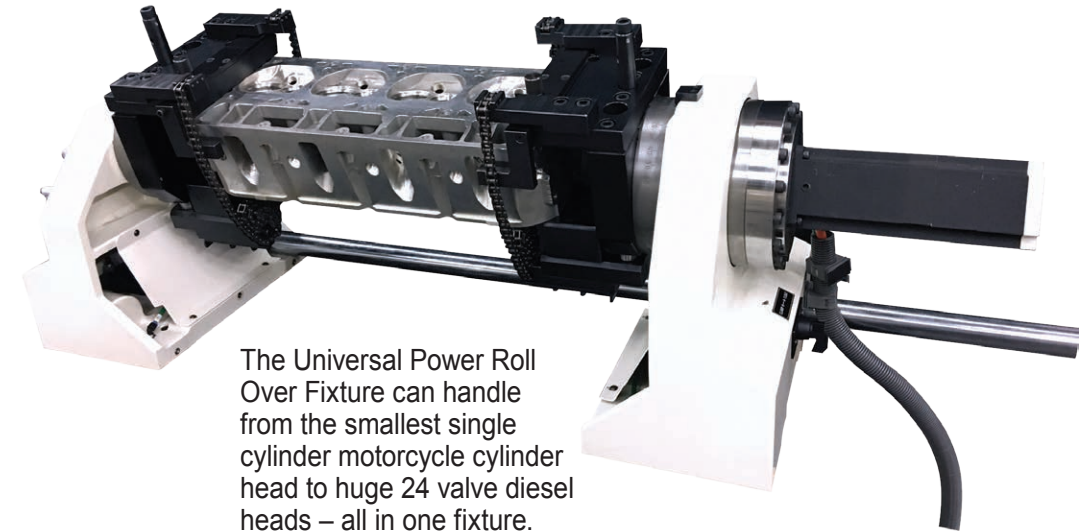

The Universal Power Roll Over Fixture can handle from the smallest single cylinder motorcycle cylinder head to huge 24 valve diesel heads – all in one fixture.

All 24 valve seats, counterbores, and guides can be machined in one set up. Fixture can be rolled 360 degrees for diesel injector and valve spring seat work. Difficult jobs like drilling broken bolts and tapping threads on side of cylinder head can be also done in same set up.

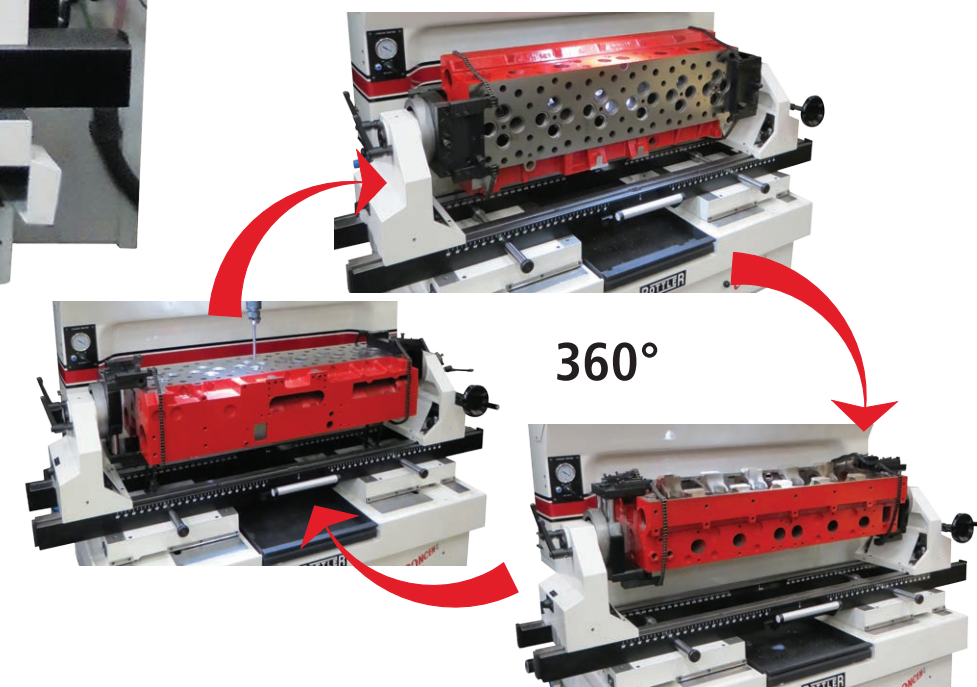

PRODUCTION APPLICATIONS

SPECIAL FIXTURES

Production Multihead Fixture

Rottler production fixture allows cylinder heads to be front loaded, pneumatically clamped upwards, machined and unloaded - fast and easy - no adjustments or leveling required.



Rottler fixtures are designed to be changed easily and fast. Connections are screw type for quick disconnect.

Rottler offer a variety of fixtures to set up most cylinder heads. When required, Rottler is able to design and manufacture special fixtures for new head manufacturing or production remanufacturing applications. The SG100XY is shown here with automatic palletized fixtures for locomotive cylinder heads.

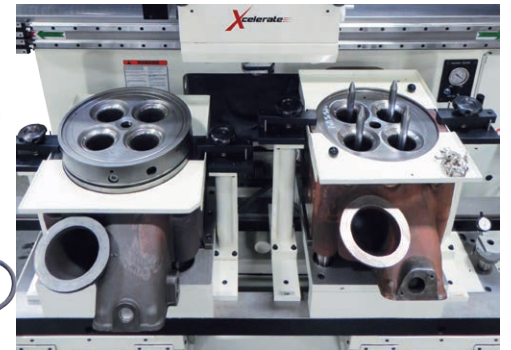

EXTRA LARGE HEADS

The SG100XY can handle from the smallest to extra large single cylinder heads. The Pedistals for the Universal Power Roll Over Fixture can be air floated to the outside and large heads such as CAT 3600 can be set up and leveled on the tilting fixture and clamped down with the Tower Clamps.

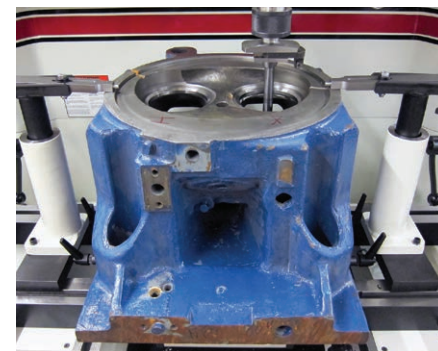
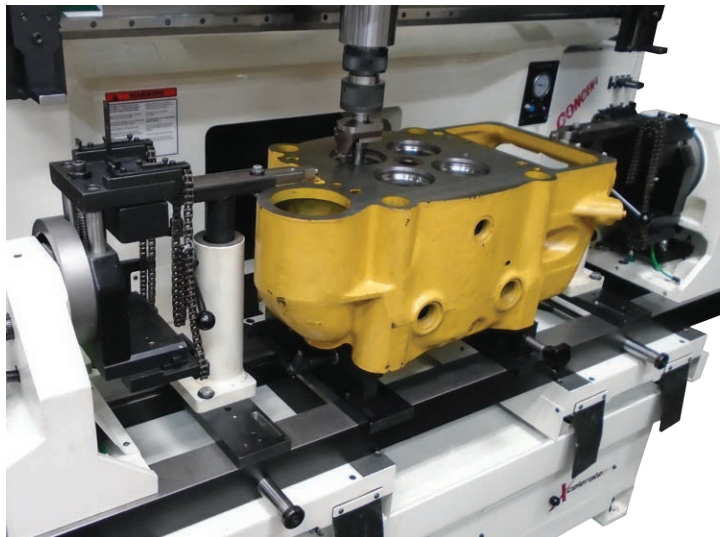

Extra Long Studs

The SG100 machines have clearance in the lower center area of the machine to allow clearance for long studs that are difficult and time consuming to remove from cylinder heads. The attached cylinder head has 17"/430mm long studs (above) that do not have to be removed to be able to set up and machine valve seats, counterbores and guides.

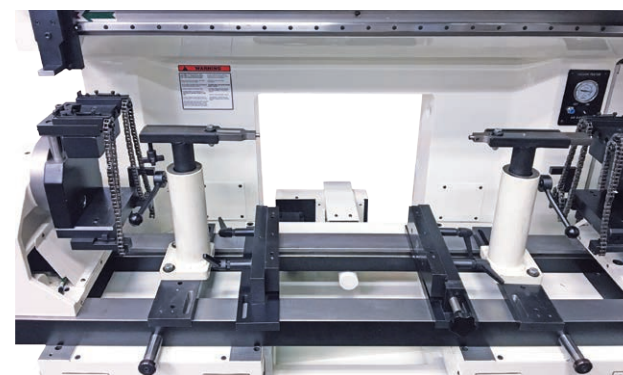
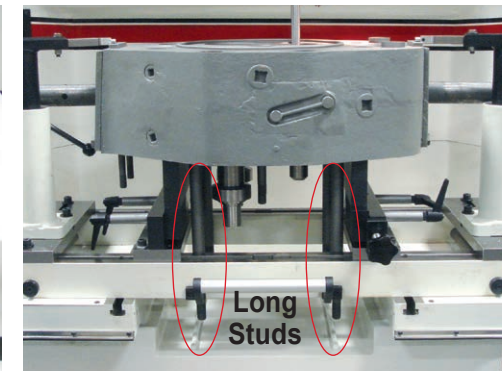
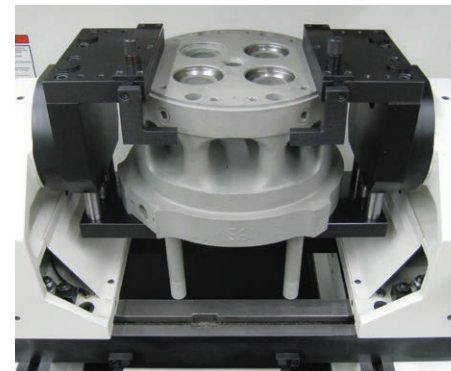

FEATURES



Tool Storage and Quick Change System

These devices allow storage of intake and exhaust tooling and allows the computer to know which tool is being used and automatically sets the correct program.

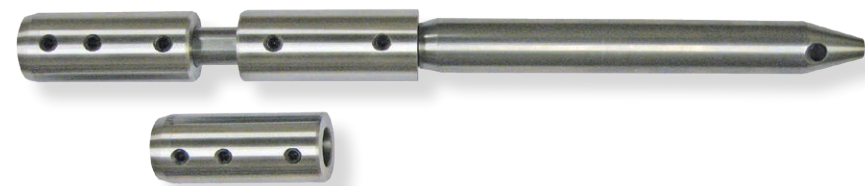

Modular Carbide Centralizing Pilot

Rottler offers a Modular Carbide Centralizing Pilot System for very large engine applications with valve guides larger than .875" (22.23mm) diameter. This system is versatile as it allows the use of different size sleeves which are adjustable for different lengths and diameters of valve guides

Triangle Tool Holders

Indexable Triangular Coated Carbide Tool Holders in 10, 20, 30, 45 degrees. Ideal and economical when cutting only one seat angle and for boring our old inserts and boring new insert housings.



CBN Cutting Inserts

CBN triangular cutting inserts are now available for cutting extremely hard valve seat materials found in natural gas, biogas and alternate fuel engines



Fixed Diameter Milling Heads

For boring seat ring housings for standard seat rings – gives correct interference for press fit with no adjusting or setting. Indexable Carbide Inserts have 4 corners and are easy to change when dull without any adjusting or setting. No need to purchase a new cutterhead when the inserts get dull.



CONCEN Gage

Rottler's **CONCEN** gage allows concentricity to be easily and quickly checked to ensure accuracy



Collet Chuck

can hold a wide range of precision tools for valve guide reaming, injector tube boring and facing, thread tapping, etc.

EXTENSIVE TOOLING AVAILABLE

Overize Valve Seat Insert Rings

The SG100XY is ideal for boring housings for overize valve seat insert rings. Rottler manufactures special adjustable cutterheads with quick change driver. Water cooled valve seats require 2 diameters to be bored with accurate **CONCENTRICITY** to prevent any water leakage. These cutterheads can be preset and used to bore both diameters.



Fire Ring Groove

Special cutterhead for machining fire ring groove in head gasket surface. Can also be used to bore large valve guide housings/bores.



Universal Chuck

Universal Chuck can be used for odd jobs like drilling out broken bolts and tapping threads

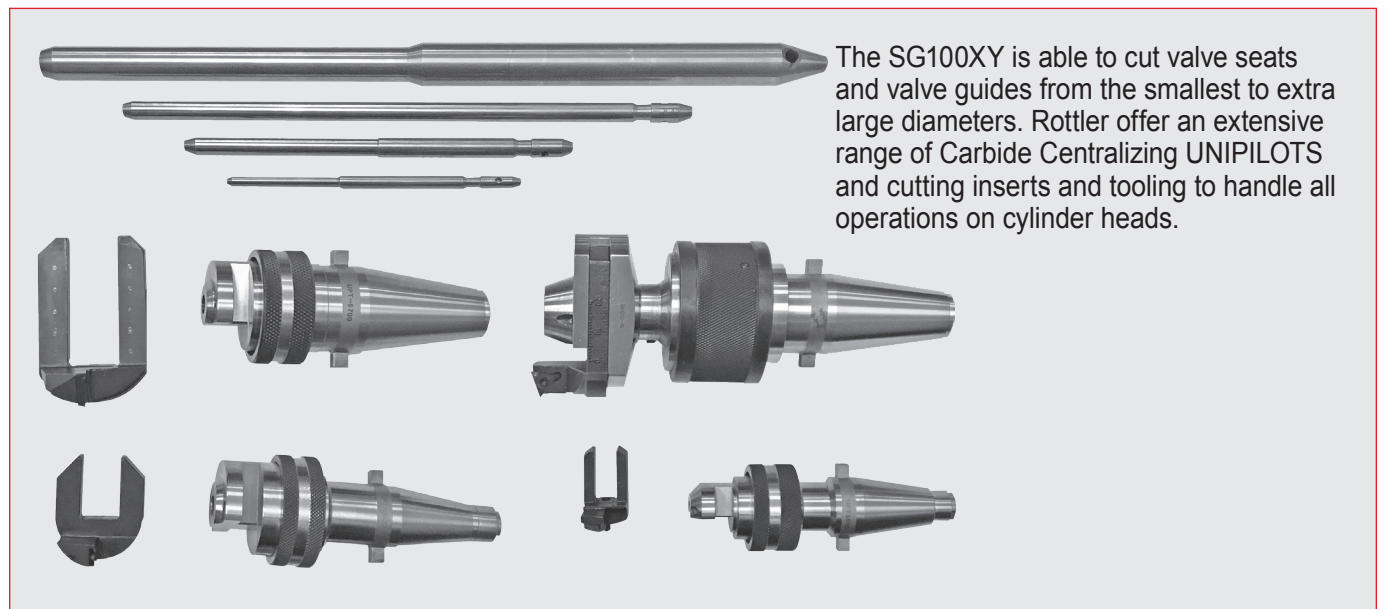

The SG100XY is able to cut valve seats and valve guides from the smallest to extra large diameters. Rottler offer an extensive range of Carbide Centralizing UNIPILOTS and cutting inserts and tooling to handle all operations on cylinder heads.

Rottler's 6 in 1 Setting Fixture makes precision valve work simple and fast!

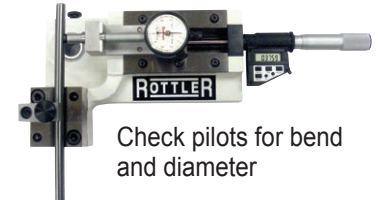
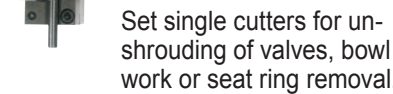
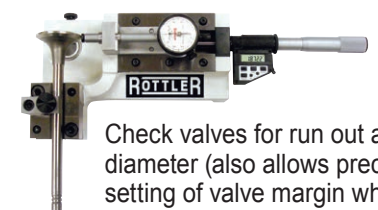
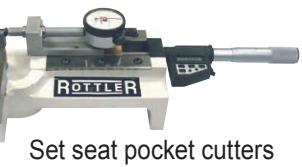
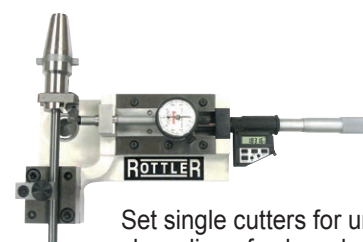

Set seat pocket cutters to proper diameter

Check valves for run out and diameter (also allows precision setting of valve margin when setting up multi-angle cutters)

Set single cutters for unshrouding of valves, bowl work or seat ring removal.

Set multi-angle seat cutters to exact diameter

Check pilots for bend and diameter

STANDARD EQUIPMENT

Standard Equipment Includes:

- Special Version Machine for Automatic Guide-to-Guide in X and Y directions allowing different lines of valve guides and seats to be machined automatically - unattended operation
- Special Alignment System for fast set up of wide variety of cylinder heads (Patent Pending)
- ACTIVE SPINDLE - Spherical Pneumatic Automatic Alignment System built into the Spindle for fast location of the pilot into the Valve Guide and Accurate Centering (Patented)
- CNC (Computer Numerical Control) Touch Screen Control using Windows Operating System and Industrial PC with Intel Processor
- Internet connection to the machine computer must be provided for future support and software updates.
- Automatic Cycles for Seat Cutting, Housing Boring, Guide Drilling and Reaming, Thread Tapping.
- Programming and Machine Operation thru 15" (380mm) extra bright touch screen.
- Electronic Hand Wheel for manual operation in .001" (.01mm) or .010" (.25mm) increments per Hand Wheel Detent
- Precision Digital Readout, .0001" (.002mm) Resolution
- On Screen Database to save all specifications, tooling, parts information
- Heavy Duty Spindle with Rottler R40 taper - Diameter 3.70" (94mm) Hardened and Ground with 10" (250mm) of vertical travel
- Rottler Automatic Tightening and Quick Release Spindle Lock Nut System for One Hand Operation for fitting and removing tooling to and from the spindle
- Spindle Travel by Precision Ball Screw & AC Servo Motor - Infinitely Variable Vertical Movement - Z Axis - Up and Down - 10" (250mm)
- Spindle Rotation by AC Servo Motor - Infinitely Variable to 1000 RPM
- Machine Work Head Floats on Air Cushion for Precision Centering
- Machine Work Head moves by servo motor in X axis by precision ball screw - 40"(1025mm) Travel
- Machine Table/Fixture moves by servo motor in Y axis on linear slideways - 6" (150 mm) Travel
- Spindle Head Tilt - 10 Degrees to left and right for canted angle valve guide cylinder heads
- SSV Spindle Speed Variation – Variable Spindle Speed during finish cut for improved surface finish.
- Built In Vacuum Tester including Hose, Filter and Pads
- 2 LED Work lights - either side of the spindle giving shadowless view of valve seat area
- Paint Color Code: RAL9002 (Grey White)

SPECIFICATIONS

	American	Metric
Valve Seat Diameter	.550-6.0"	152mm
Maximum Cylinder Head Length (with Servo Roll Fixture)	50"	1270mm
Spindle Speed	Variable to 1000 rpm	
Maximum Spindle Stroke - Vertical	10"	250mm
Maximum Tilt (either side of zero)	5 degrees	
Electrical Requirements	208/220V, 15A, 50/60Hz, 1Ph	
Air Requirements	90-100 psi	6-6.6 BARS
Spindle Motor Torque	14.75 ft. lbs	20NM
Machine Dimensions	86" wide x 50" deep x 88" high	2184mm x 1270mm x 2235mm
Shipping Dimensions	88" wide x 56" deep x 94" high	2235mm x 1422mm x 2388mm
Shipping Weight	3200 lbs	1455 kg

Specifications and design subject to change without notice.

August 2018

www.rottlermfg.com

www.youtube.com/rottlermfg
www.facebook.com/rottlermfg
contact@rottlermfg.com

8029 South 200th Street
 Kent, Washington 98032 USA
 +1 253 872 7050

Represented by:

1-800-452-0534